

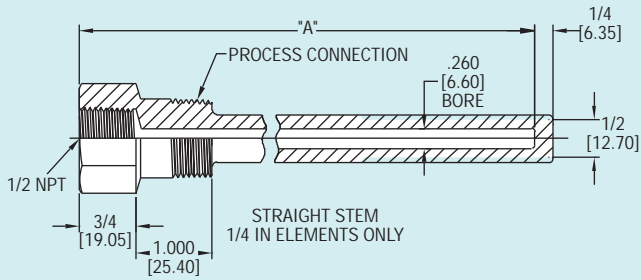

Thermowells

Select bore as 0.260 for 1/4" diameter elements and 0.390 for 3/8" diameter elements. Specify heavy duty mounting for tapered sheaths.

Straight Stem



Tapered Flanged

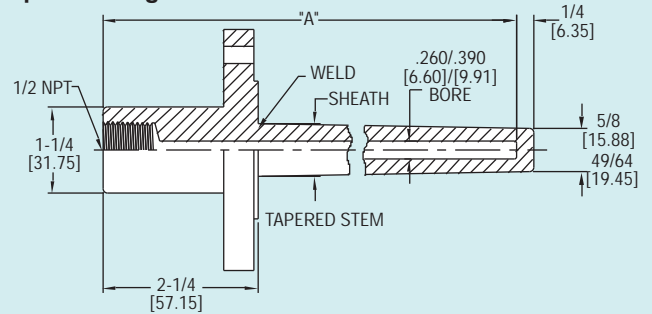

Tapered Stem

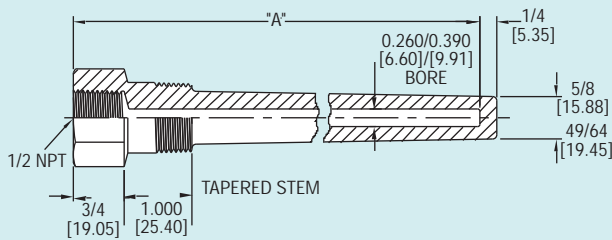

Straight Flanged

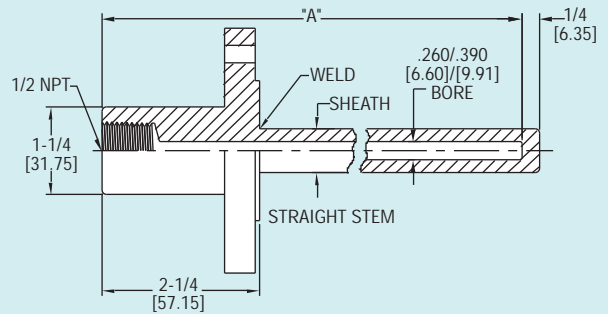

Stepped Stem

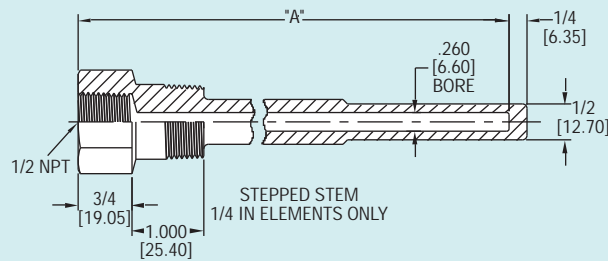

Model Coding - Thermowells

Fill in the appropriate numbers or letters to specify the thermowell of your choice. Fill in all boxes. If an item or dimension does not apply, fill those boxes with zeros '0'.

W - -

A Dimension Specify in 4, 6, 9, 12, 15, 18, Or 24"

- HARDWARE TYPE**
 1 - 304 SS Sheath
 2 - 316 SS Sheath
 3 - Brass
 4 - Carbon Steel

- INSIDE THREAD**
 1 - 1/2" female NPT

- TAPER AND BORE**
 0 - Straight / 0.260
 1 - Step / 0.260
 2 - Straight / 0.390
 3 - Taper / 0.260
 4 - Taper / 0.390

- PROCESS CONNECTION**
 1 - 1/2 NPT
 2 - 3/4 NPT
 3 - 1 NPT
 4 - 1" 150# Flange
 5 - 1-1/2" 150# Flange
 6 - 2" 150# Flange
 7 - 1" 300# Flange
 8 - 1-1/2" 300# Flange
 9 - 2" 300# Flange
 A - 1" 600# Flange
 B - 1-1/2" 600# Flange
 C - 2" 600# Flange

- MOUNTING**
 1 - Threaded
 2 - Heavy Duty Threaded
 3 - Heavy Duty Flanged
 4 - Flanged

- LAG**
 0 - None
 2 - 2"
 3 - 3"

- SHEATH O.D. Base/Taper**
 1 - 5/8" / 1/2"
 4 - 3/4" / 1/2"
 6 - 7/8" / 1/2"
 7 - 7/8" / 5/8"
 8 - 1-1/16" / 5/8"
 9 - 7/8" / 49/64"
 A - 1-1/16" / 49/64"
 B - 1/2" straight
 C - 49/64" straight
 D - 7/8" straight
 E - 3/4" straight