



PF SERIES

Plate and Frame Heat Exchangers

PLATE AND FRAME HEAT EXCHANGERS

Plate and frame heat exchangers consist of a series of high efficiency gasketed embossed plates, arranged alternately and bolted together between end frames, separating cold fluid from hot fluid.

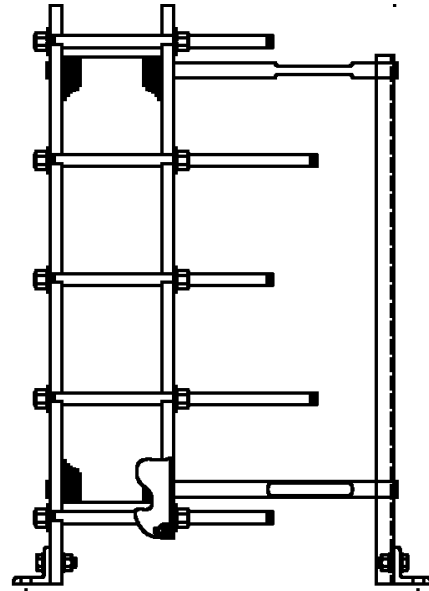

Features

- High efficiency removable and fully cleanable 304 stainless steel gasketed plates
- Heavy-duty epoxy coated frame
- Upright, compact, and a small footprint
- Low pressure drop plate design
- Self-cleaning turbulent flow velocity profile design

Options

- Protective shroud

PF SERIES

Plate and Frame Heat Exchangers

SPECIFICATIONS: 3F APPROACH

3F Approach: Process side 98°F to 88°F (37°C to 31°C), tower side 85°F to 95°F (29°C to 35°C)

Note: Consult factory for other conditions. Flow rate in gpm (lpm) for hot and cold side fluids = tons (Kcal/hr) x 3

Model no.	Tower capacity, tons (Kcal/hr)	Connection size, in.	Plate quantity, supplied	Plate quantity, maximum	Length, in. (cm)	Width, in. (cm)	Height, in. (cm)	Weight, lbs. (kg)
PF-010-3	10 (37,800)	2	21	43	29 (74)	14 (36)	48 (122)	516 (233)
PF-015-3	15 (56,700)	2	31	43	29 (74)	14 (36)	48 (122)	538 (245)
PF-020-3	20 (75,600)	2	39	43	32 (81)	14 (36)	48 (122)	555 (252)
PF-025-3	25 (94,500)	2	49	65	39 (99)	14 (36)	48 (122)	604 (275)
PF-030-3	30 (113,400)	2	59	65	39 (99)	14 (36)	48 (122)	626 (285)
PF-040-3	40 (151,200)	2	77	110	50 (127)	14 (36)	48 (122)	672 (306)
PF-050-3	50 (189,000)	2	97	110	50 (127)	14 (36)	48 (122)	716 (326)
PF-060-3	60 (226,800)	4	54	97	44 (112)	22 (56)	62 (157)	1,526 (693)
PF-075-3	75 (283,500)	4	67	97	44 (112)	22 (56)	62 (157)	1,589 (722)
PF-100-3	100 (378,000)	4	89	97	44 (112)	22 (56)	62 (157)	1,695 (769)
PF-125-3	125 (472,500)	6	60	109	58 (147)	30 (76)	85 (216)	3,718 (1,688)
PF-150-3	150 (567,000)	6	71	109	58 (147)	30 (76)	85 (216)	3,824 (1,737)
PF-175-3	175 (661,500)	6	82	109	58 (147)	30 (76)	85 (216)	3,929 (1,784)
PF-200-3	200 (756,000)	6	93	109	58 (147)	30 (76)	85 (216)	4,035 (1,832)
PF-250-3	250 (945,000)	6	137	155	64 (163)	25 (64)	72 (183)	2,764 (1,255)
PF-300-3	300 (1,134,000)	6	163	251	88 (224)	25 (64)	72 (183)	2,997 (1,361)
PF-400-3	400 (1,512,000)	6	221	251	88 (224)	25 (64)	72 (183)	3,323 (1,509)
PF-500-3	500 (1,890,000)	6	281	346	112 (284)	25 (64)	72 (183)	4,157 (1,888)
PF-600-3	600 (2,268,000)	8	201	219	93 (236)	35 (89)	92 (234)	6,638 (3,014)



PF SERIES

Plate and Frame Heat Exchangers

SPECIFICATIONS: 5F APPROACH

5F Approach: Process side 100°F to 90°F (38°C to 32°C), tower side 85°F to 95°F (29°C to 35°C)

Note: Consult factory for other conditions. Flow rate in gpm (lpm) for hot and cold side fluids = tons (Kcal/hr) x 3

Model no.	Tower capacity, tons (Kcal/hr)	Connection size, in.	Plate quantity, supplied	Plate quantity, maximum	Length, in. (cm)	Width, in. (cm)	Height, in. (cm)	Weight, lbs. (kg)
PF-010-5	10 (37,800)	2	15	49	29 (74)	14 (36)	39 (99)	415 (189)
PF-015-5	15 (56,700)	2	21	49	29 (74)	14 (36)	39 (99)	425 (193)
PF-020-5	20 (75,600)	2	49	49	29 (74)	14 (36)	39 (99)	425 (193)
PF-025-5	25 (94,500)	2	49	49	29 (74)	14 (36)	39 (99)	449 (204)
PF-030-5	30 (113,400)	2	41	49	29 (74)	14 (36)	39 (99)	459 (209)
PF-040-5	40 (151,200)	2	53	71	36 (91)	14 (36)	39 (99)	501 (228)
PF-050-5	50 (189,000)	2	67	71	36 (91)	14 (36)	39 (99)	524 (238)
PF-060-5	60 (226,800)	4	55	65	36 (91)	14 (36)	48 (122)	617 (281)
PF-075-5	75 (283,500)	4	43	49	31 (79)	21 (53)	54 (137)	1,135 (516)
PF-100-5	100 (378,000)	4	57	62	39 (99)	21 (53)	54 (137)	1,216 (553)
PF-125-5	125 (472,500)	6	67	97	44 (112)	22 (56)	62 (157)	1,589 (722)
PF-150-5	150 (567,000)	6	87	154	63 (160)	21 (53)	54 (137)	1,383 (628)
PF-175-5	175 (661,500)	6	95	145	44 (112)	22 (56)	62 (157)	1,724 (783)
PF-200-5	200 (756,000)	6	119	154	63 (160)	21 (53)	54 (137)	1,478 (672)
PF-250-5	250 (945,000)	6	149	175	63 (160)	21 (53)	54 (137)	1,567 (712)
PF-300-5	300 (1,134,000)	6	89	155	64 (163)	25 (64)	72 (183)	2,494 (1,133)
PF-400-5	400 (1,512,000)	6	123	155	64 (163)	25 (64)	72 (183)	2,685 (1,219)
PF-500-5	500 (1,890,000)	6	163	251	88 (224)	25 (64)	72 (183)	2,997 (1,361)
PF-600-5	600 (2,268,000)	8	211	251	88 (224)	25 (64)	72 (183)	3,267 (1,484)

PF SERIES

Plate and Frame Heat Exchangers

DIMENSIONS

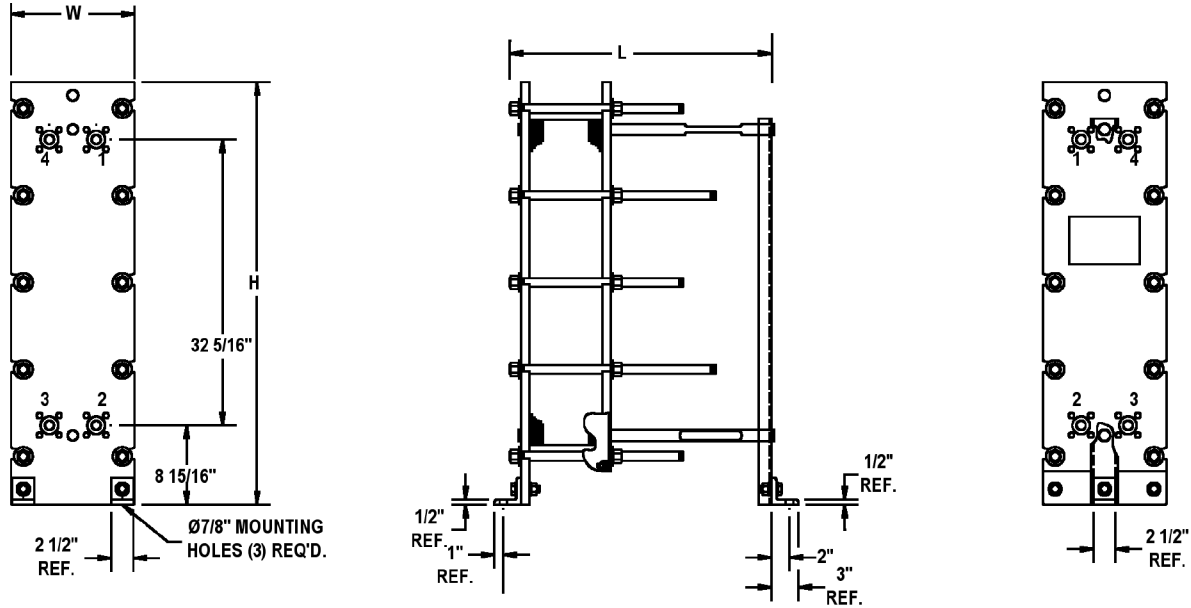

CLOSED LOOP SYSTEM

