

## SERIES LF460 ALARM, MODEL LF4600150 Temperature Alarm System

### Technical Instructions

# LEAD FREE\*

#### ⚠ WARNING



Read this Manual **BEFORE** using this equipment. Failure to read and follow all safety and use information can result in death, serious personal injury, property damage, or damage to the equipment. Keep this Manual for future reference.



#### Description ■

The Series LF460 Aqua Sentry 2 Alarm System monitors for high or low temperature conditions. The system utilizes an accurate solid state temperature sensor and microprocessor based digital circuitry to sense and report abnormal temperature conditions. Standard sensing range is  $-40^{\circ}\text{F}$  to  $199^{\circ}\text{F}$  or  $-40^{\circ}\text{C}$  to  $93^{\circ}\text{C}$  (switchable). The alarm panel can be mounted remotely and provides both audible and visual indication of alarm condition. With the addition of a solenoid, the alarm can function as an emergency shutdown system.

A unique latching circuit is used so that the alarm holds despite a return to normal condition. This feature indicates that a dangerous condition did exist. The alarm can be silenced at any time by pressing the reset key. After the temperature returns to normal, the system can be reset by pressing the reset key twice. The system cannot be reset while the temperature is outside the setpoints. The alarm module can be panel mounted, or installed in a standard 4 x 4 electrical wall box (supplied).

Use of the Series LF460 Aqua Sentry II Alarm System, along with an electrically actuated valve, helps assure requirements are met to maintain delivery temperature below (or above) a certain temperature. (Typical of domestic water systems in health care and nursing facilities).

#### Mode of Operation ■

##### I. Standard Operation of the Series LF460 Alarm connected as shown in Figure 3 on page (3):

- A. Display will read current temperature with sensor connected and system in "safe" condition.
- B. If sensor is improperly connected or if the sensor is properly connected and there is an increase in the water temperature above or below the setpoints of the thermostat:
  1. Audio alarm will sound.
  2. Display will flash.
  3. Current temperature will be displayed.
  4. Valve will close.

##### If condition 1-B occurs, press RESET key twice.

- A. If the sensor is properly connected and a dangerous condition exists, the circumstances described in I-B (2, 3, 4) will persist.
- B. If the sensor is improperly connected, the circumstances described in I-B (2, 4) will persist.
- C. If the sensor is connected properly, and the system is in a safe condition:
  1. Alarm will be silent.
  2. Display will be on.



Figure 1—Dimensional Data

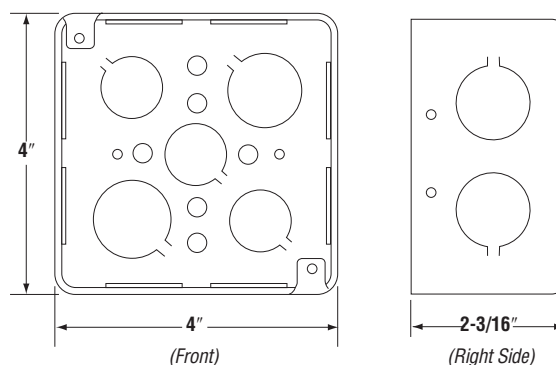

Note: Position of mounting holes on utility box must match up with the holes on Series 460 alarm front panel.

3. Current temperature will be displayed.
4. Valve will open.

##### II. To test the Series 460 alarm, press the keys marked ▼ and "RESET" simultaneously.

- A. Audio alarm should sound.
- B. Display will flash.
- C. Valve will close.

##### To terminate the audio alarm, press the "RESET" key and release.

- A. Audio alarm will turn off.
- B. Display will continue to flash.
- C. Valve will remain closed.

##### To terminate test condition, press "RESET" key again.

- A. Display will stop flashing.
- B. Temperature will be displayed.
- C. Valve will open.

\*The wetted surface of this product contacted by consumable water contains less than 0.25% of lead by weight.

## Sensor Installation ■

1. Locate a suitable point to install sensor. This should be either at the source of medium being monitored (water heater, boiler, master mixer, etc.), or at any specific point within the system that needs to be monitored. For typical domestic tempered water systems, sensor should be installed 2' to 5' from the mixing valve.
2. Install a pipe "T" in the line, and install reducer bushing (if required) to reduce the out branch to 1/2" NPT.
3. Install the 1/2" NPT to 1/4" sensor adaptor (supplied) to the pipe "T".
4. Slide the temperature sensor into the adapter until the tip is in the approximate center of the flow, and secure by tightening the compression nut.

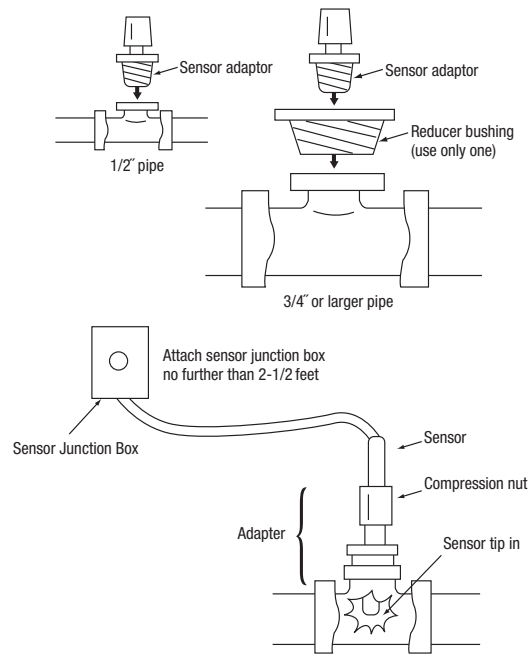

Figure 2—Sensor Installation

## Installation ■

1. Mount electrical box to stud or other wall surface, so front panel is flush with wall. Position box so that mounting screws are in the upper left and lower right locations.
2. Mount sensor junction box within 2½ feet from sensor location.
3. Mount the transformer on an appropriate electrical box and insure 120 VAC is available. (Do not connect power at this time.)
4. Run wire (16–18 gauge stranded wire) from the transformer secondary (two screw terminals) to the 4 x 4 Aqua Sentry electrical box. Leave approximately 6" for connections in the box.
5. Run sensor cable from the sensor junction box to the 4 x 4 Aqua Sentry electrical box. Leave approximately 6" at each end.
6. Connect wires as shown in Figure 3 if using solenoid valve or figure 4 if using motorized valve.
7. Plug Sensor into sensor junction box.
8. Carefully tuck excess wire into the 4 x 4 Aqua Sentry electrical box and screw module into box.
9. To use shutoff feature, wire as follows (see Figure 3 or 4):  
Terminal 8: Common  
Terminal 7: Normally open  
Terminal 6: Normally closed
9. Ensure all electrical wiring conforms to local and National electrical codes.
10. Connect 120 VAC to transformer primary input.

## Operating Instructions ■

Apply power to the panel. The correct process temperature should be displayed on the display. If the audio indicator is sounding, press the "RESET" key twice. The shutoff valve (if used) should be open, and the AquaSentry 2 should now be functional.

- If the display does not indicate the correct temperature, refer to the troubleshooting instructions.
- If the display is flashing, the process is outside setpoint limits. Either correct the process temperature, or change the setpoints. Press the "RESET" key again. The display should stop flashing, and the shutoff valve (if used) should open.

### When the alarm sounds:

- Press the "RESET" key to silence the audio indicator.
- Take necessary actions to correct the cause of the over/under temperature condition.
- When the temperature on the display returns to within setpoint limits, press the "RESET" key again to reset the alarm. The display should stop flashing, and the shutoff valve (if used) should open.
- If the temperature on the display is not within setpoint limits, the alarm will not reset, the shut-off will remain closed, and the display will continue to flash.

**Transformer**

2 wires Connect to 117 VAC  
 2 screw terminals Connect to module terminals 1 and 2

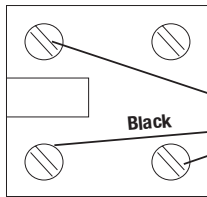

**Sensor Junction Box**

Red Sensor power—Red wire  
 Yellow Sensor signal—Yellow wire  
 Black Sensor return—Black wire  
 Green N-C

**Solenoid (Optional)**

Jumper terminals 2 and 6  
 Connect solenoid to terminals 1 and 8

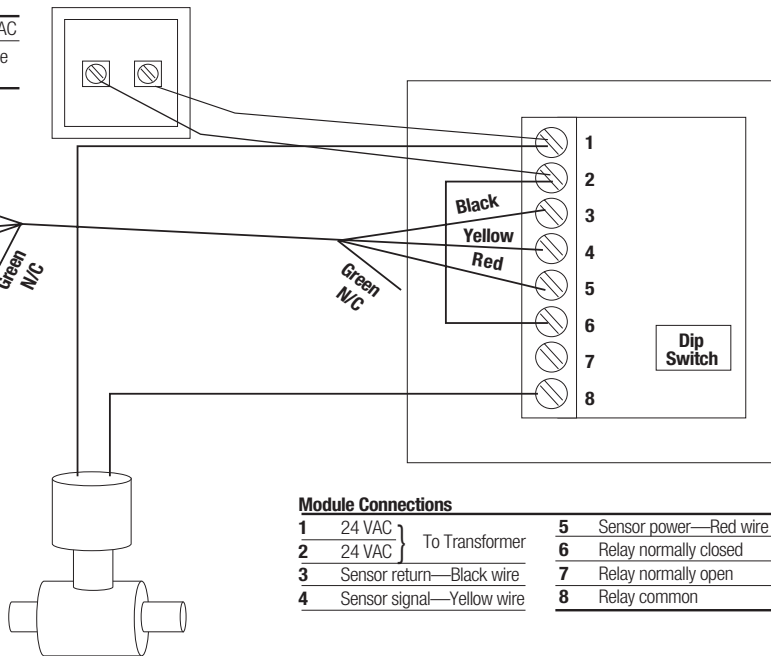

**Module Connections**

1	24 VAC	} To Transformer	5	Sensor power—Red wire
2	24 VAC		6	Relay normally closed
3	Sensor return—Black wire		7	Relay normally open
4	Sensor signal—Yellow wire		8	Relay common

**Figure 3—Wiring for solenoid valve (solenoid valve supplied by others)**

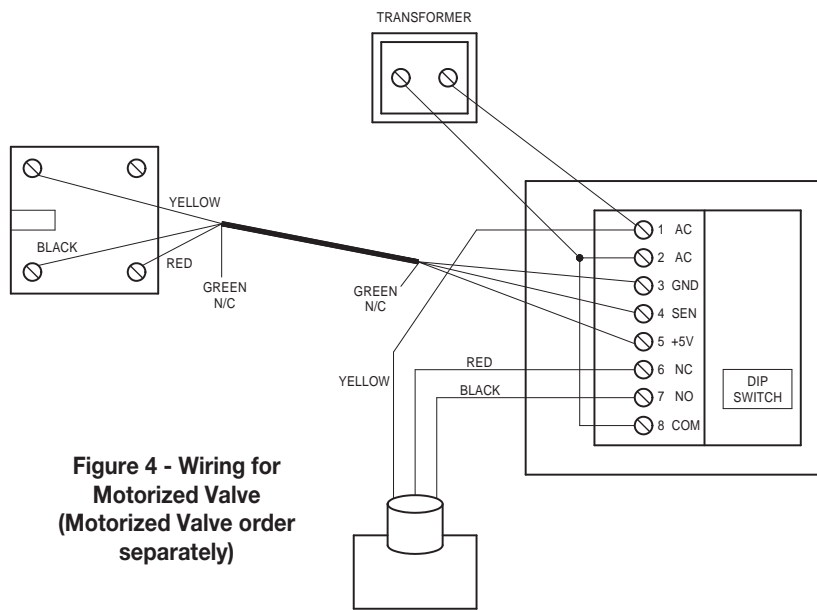

**Figure 4 - Wiring for Motorized Valve (Motorized Valve order separately)**

**Configuration Instructions ■**

1. Apply power to the panel. The correct process temperature should be displayed on the display. If the alarm is sounding, press the "RESET" key once.
2. Ensure dip switch #2 on the circuit board is in the off position. (This switch "locks out" the "SET" key if activated.)
3. Press the "SET" key twice to display "HSP" (high setpoint) value. Use the up or down arrow keys to set the upper setpoint.
4. Press the "SET" key twice to display "LSP" (low setpoint) value. Use the up or down arrow keys to set the lower setpoint. If no low alarm is used, set the lower setpoint for 32–35°. (This will ensure that the alarm will sound if the probe is damaged or disconnected.)

5. Press the "SET" key three (3) times to return to the operating mode. Press the "RESET" key if the display is flashing. Unit should now be fully functional.
6. Position dip switch #2 on the circuit board on the "on" position to prevent unauthorized configuration changes.

**NOTICE**

If there is a difference between the reading on the display and the actual process temperature, note the number of degrees the reading is off. Press the "SET" key 6 times, then enter the different temperature in the CAL setting with the up and down arrow key. Press the "SET" key one more time to return to the operate mode.

## Troubleshooting Instructions ■

1. The Aqua Sentry 2® has been carefully engineered to be as simple to install, and as reliable as possible. Should you have difficulty, please use the following guide to identify the cause of the problem.

### **Display does not light up**

- Make sure the power is on.
- Ensure the transformer is properly wired to terminals 1 and 2 or the control unit.

### **Display indicates 205° or has a negative reading all the time**

- Sensor is not plugged into the junction box.
- Junction box is incorrectly wired to the control unit; check wiring, and correct.
- Sensor probe is defective.

### **Display flashes continuously and cannot be reset**

- Check the alarm setpoints, ensure the actual temperature is between the low and high setpoints.

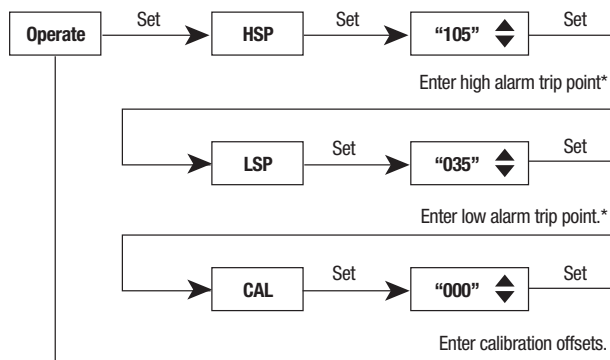

\* Values can be changed by pressing the ▼ or ▲ keys.

**Figure 5—Configuration**

**WARNING:** This product contains chemicals known to the State of California to cause cancer and birth defects or other reproductive harm.  
**For more information:** [www.watts.com/prop65](http://www.watts.com/prop65)

## Warranty ■

The Seller warrants that the equipment manufactured by it and covered by this order or contract is free from defects in material and workmanship and, without charge, equipment found to be defective in material or workmanship will be repaired, or at Seller's option replaced F.O.B. original point of shipment, if written notice of failure is received by Seller within one (1) year after date of shipment (unless specifically noted elsewhere), provided said equipment has been properly installed, operated in accordance with the Seller's instructions, and provided such defects are not due to abuse or decomposition by chemical or galvanic action. THIS EXPRESS WARRANTY IS IN LIEU OF AND EXCLUDES ALL OTHER WARRANTIES, GUARANTEES, OR REPRESENTATIONS, EXPRESS OR IMPLIED. THERE ARE NO IMPLIED WARRANTIES OF MERCHANTABILITY OR OF FITNESS FOR A PARTICULAR PURPOSE. The Seller assumes no responsibility for repairs made on the Seller's equipment unless done by the Seller's authorized personnel, or by written authority from the Seller. The Seller makes no guarantee with respect to material not manufactured by it.

**POWERS™**

A Watts Water Technologies Company

**ISO 9001-2008  
CERTIFIED**