

### Technical Instructions

#### Features ■

- Low cost
- Built-in volume booster
- Small size
- Field reversible
- Low air consumption
- Mounts at any angle
- Convenient external Span and Zero adjusts
- Light Weight
- Wide supply pressure range
- Low supply pressure sensitivity



#### Operating Characteristics ■

Supply Pressure Range:	Min: 3 psig (21 kPa) above max output Max: 100 psig (700 kPa)
Supply Pressure Sensitivity:	<±0.15% of span per 10 kPa at midrange (<±0.1% of span per psig)
Terminal Based Linearity:	<±1.0% of span
Repeatability:	<0.5% of span
Hysteresis:	<1.0% of span
Air consumption (Maximum):	0.1 SCFM (0.2m³/hr) at midrange
Flow Rate at Midrange (Minimum):	4.5 SCFM (7.6m³/hr ANR) at 25 psig (175 kPa) supply; 12 SCFM (20.0 m³/hr ANR) at 100 psig (700 kPa) supply
Port Sizes:	1/4 NPT (pneumatic); 1/2 NPT (electric)
Size:	2-1/8 in. x 2-1/8 in. x 4 in. (54 mm x 54 mm x 102 mm)
Weight:	2.1 lb (0.94 kg)
Impedance (nominal):	512-117 ... 180 512-015 ... 180 512-027 ... 220

#### Description ■

This transducer is an electropneumatic device that reduces a supply pressure to a regulated output pressure that is directly proportional to an electrical input signal. It uses a supply pressure between 18 and 100 psig (125-700 kPa). An integral pneumatic volume booster is included in the design to provide high flow capacity (up to 12 SCFM).

Three versions of the compact transducers are available. Listed below are their model numbers, the current input accepted by each, and output signal emitted by each.

- 512-117...4-20 mA Input/1-17 psi Output
- 512-015...4-20 mA Input/3-15 psi Output
- 512-027...4-20 mA Input/3-27 psi Output

#### Operating Principle ■

The I/P transducer is a force balance device in which a coil (see figure 1 on page 2) is suspended in the field of a magnet by a flexure. Current flowing through the coil generates axial movement of the coil and flexure. The flexure moves against the end of a nozzle and creates a back pressure in the nozzle by restricting air flow through it. This back pressure acts as a pilot pressure to an integral booster replay. Consequently, as the input signal increases (or decreases, for reverse acting), output pressure increases proportionally. Zero and span are calibrated by turning easily accessible adjusting screws on the front face of the unit. The zero adjusting screw causes the nozzle to move relative to the flexure. The span adjusting screw is a potentiometer that limits the current through the coil. A thermistor in series with the coil provides temperature compensation.

## Mounting

The 512 series transducers can be pipe, panel, or bracket mounted in any position. Positions other than vertical will require recalibration of the zero adjustment. For maximum output pressure stability, the transducer should be mounted in a vibration-free location or such that vibration is isolated to the X and Z axis shown on the dimensional drawing (see Figure 2 on page 3).

## Field Reversible

All transducers are calibrated at the factory for direct acting operation but may be used in the reverse acting mode by reversing the polarity of the signal leads and recalibrating. When calibrated for reverse acting applications, the transducers provide a minimum of their full rated output pressure (i.e., 15, 17, or 27 psig) upon input signal failure.

## Installation ■

### Mounting

#### Pipe:

Due to its light weight, the transducer may be supported using its own plumbing on pipes used for air supply and output.

#### Panel (with access to rear of panel):

Attach transducer to panel using two 10-32 screws (supplied) into the threaded holes on the back of the transducer.

#### Panel (with no access to rear of panel):

Attach bracket using two 10-32 screws (supplied) into the threaded holes on the back of the transducer. Use 10-32 screws through holes in the bracket to mount transducer to panel.

#### Flowrite II Valve:

For mounting in the field, use mounting kit (optional accessory, #512-005), which contains an adaptor bracket (AB). First, attach this AB to the yoke, then attach the mounting bracket (shown in Figure 2-supplied with transducer) to the AB.

#### Mounting Notes:

1. Transducer may be mounted at any angle. See "Calibration."
2. Effect of external vibration can be kept at a minimum if unit is mounted so that vibration is restricted to being along the X and Z axes shown on the Dimensional Drawing, see figure 2.

#### Air Connections:

##### Supply

Connect air supply to 1/4 NPT port marked "IN" on base of unit. Avoid getting pipe compound in air line and transducer. Supply air must be instrument quality (filtered and dried).

Figure 1

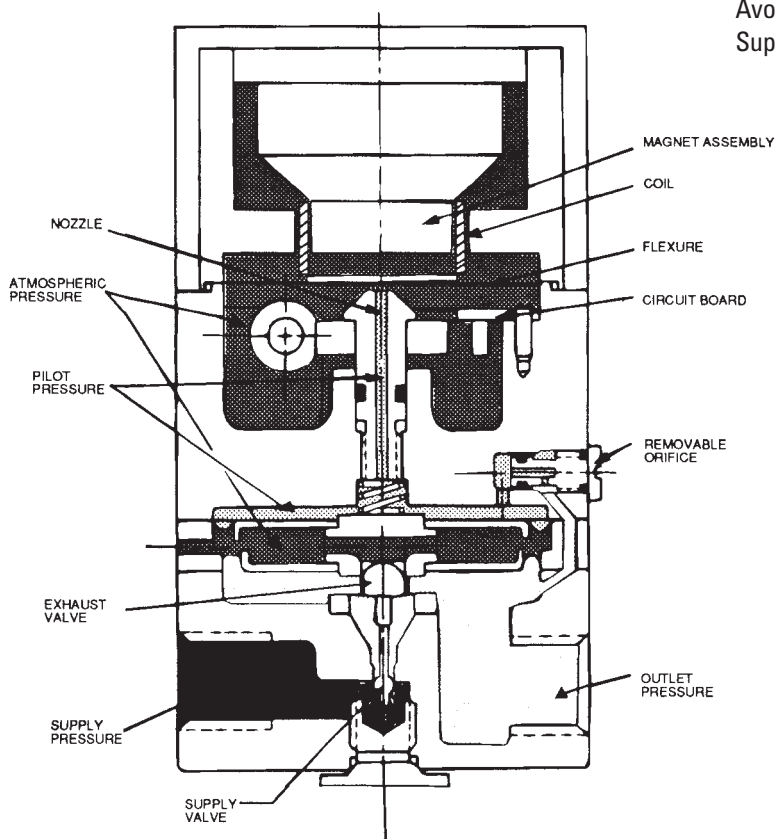

**Output:**

Connect output to 1/4 NPT port marked "OUT" on base of unit. The two unmarked 1/4 NPT ports may be used as alternate output ports or for a gauge to measure output pressure. Unused ports must be plugged.

**Electrical Connections:**

Connect electrical signal to leads exiting side of unit through 1/2 NPT conduit fitting. For direct acting (where increasing signal increases output pressure), connect positive signal to black lead and negative to white. For reverse acting (increasing signal decreases output pressure), connect positive signal to white lead and negative to black.

**Calibration ■**

Transducer should be calibrated after mounting. If transducer is calibrated in an upright position, then mounted at an angle, readjustment of the "ZERO" is necessary.

1. Remove plastic cap from "ZERO" and "SPAN" adjustment screw access holes.
2. Set signal to low end of the signal scale. (For reverse acting, set to high end of the signal scale).
3. Adjust "ZERO" screw until output pressure is set to the low end of the output scale. Turn counterclockwise to increase pressure, clockwise to decrease pressure. If output pressure does not change when screw is turned, turn screw counterclockwise until pressure starts to rise.

4. Set signal to high end of the signal scale. (For reverse acting, set to low end of the signal scale).
5. Adjust "SPAN" screw until output pressure is set to the high end of the output scale.
6. Repeat steps 2, 3, 4, and 5 until no further readjustment is necessary.
7. Replace protective caps.

**Maintenance ■**

If internal clogging occurs due to improper filtering of the supply air, the orifice can be cleaned without removing the unit from its mounting or plumbing. Turn off the supply air. Unscrew and remove the orifice assembly. Clean the orifice through the side of the orifice assembly using a wire that has a smaller diameter than 0.015 in. (0.38 mm). Shake out any loose particles inside of the orifice assembly. Screw orifice assembly back into unit.

**CALIFORNIA PROPOSITION 65 WARNING**  
**WARNING:** This product contains chemicals known to the State of California to cause cancer and birth defects or other reproductive harm. (California law requires this warning to be given to customers in the State of California.)  
 For more information: [www.watts.com/prop65](http://www.watts.com/prop65)

