

CX-742E
AUGUST 10, 2005

25SU3-5166 /5168
SHOWN WITH OPTIONAL
DISPLAY MODULE INSTALLED

TYPE 25SU3-5166/5168

CONTROL SYSTEM DESCRIPTION FLAME AMPLIFIER, WIRING BASE, SCANNERS, AND DISPLAY



WARNING: This bulletin is directed to the licensed boiler service technicians and professional combustion engineers who are experienced in the installation and operation of flame safeguard controls. Persons not experienced with flame and combustion controls should contact the nearest Fireye distributor, representative, or a qualified service group for assistance. Improper installation of these products may be hazardous to life and property.

DESCRIPTION

The FIREYE® Type 25SU3-5166/5168 control confirms the presence or absence of a flame to provide reliable ignition and flame failure protection in an industrial or utility combustion application. The difference between the 25SU3-5166 and the 25SU3-5168 is in the characteristics of the amplifier sensitivity. The 5166 has high discrimination (low sensitivity) and the 5168 has high sensitivity (low discrimination). It should be used only in conjunction with a Fireye Type 45UV5, 45RM1, 45RM2, 45RM4, 45FS1, or 45UVFS1 flame scanner to provide repetitive self-checking of the flame safeguard system. Compatible flame scanners for the 25SU3 Model 5166/5168 control include:

- 45UV5-1000, 1010, 1101
- 45RM1 Series
- 45RM2 Series
- 45RM4 SERIES
- 45FS1
- 45UVFS1

Dimension drawings of the control and wiring base are shown on page 15 of this bulletin.

For detailed information concerning:

Type 45RM1 and Type 45RM2 scanners	see Bulletin CU-26
Type 45UV5 scanners	see Bulletin CU-22
Type 45FS1 scanners	see Bulletin CU-32
Type 45RM4 scanners	see Bulletin CU-31
Type 45UVFS1 scanners	see Bulletin CU-32

APPLICATIONS

The Fireye Type 5166/5168 control provides flame safeguard interlock capability for systems incorporating single and multiple burner firing apparatus. Typical applications include power generation, industrial processes, pulp and paper mills, chemical plants, and electric utility furnaces and boilers that fire gas, oil, pulverized coal or a combination of these fuels on a continuous basis. The 5166/5168 control can also be applied in the flame safeguard circuits of supervised manual and semiautomatic burner management systems. This control monitors flame to supervise burner operation throughout the entire burner firing cycle.



The 5166 with high discrimination amplifier should be used in those applications where the scanner pulse ratio from flame-on to flame-off is low (< 3:1). The 5168 with high sensitivity amplifier should be used in those applications where the scanner pulse ratio from flame-on to flame-off is large (> 3:1).

During normal burner start-up and operation, the 5166/5168 control proves the presence of flame and activates auxiliary equipment to indicate flame status and permit the delivery and ignition of fuel to the burner. In the event of an ignition or flame failure, the control can provide the primary shut-down contact to the control circuitry. Using this primary contact, the control circuit designer can provide functions such as visual indication of flame and ignition presence, alarm indication, shutdown of ignition power and control of the shutoff valve. An external connection diagram is shown later in this bulletin.

WARNING



The product described in this bulletin is expected to be used as one element in the entire flame safeguard control system. This product is not considered the entire system and its' safe application is dependent on the system design. The user should insure that a licensed professional combustion engineer has designed and tested the entire burner management system. This system should also comply with all appropriate safety standards. This product must be used with an external interlock device unless it solely functions as a flame status indicator. The selected flame failure response time (FFRT) must be compatible with the FFRT requirements of the combustion system on which it is installed.

SPECIFICATIONS

Supply Voltage:	120 VAC/230 VAC (+10%, -15%), 50/60 Hz	
Max. FFRT:	1, 2, 3, Sec. Selectable	
Power Consumption:	(Control with one scanner) 13 VA, Power Factor 70% Inrush at turn on, 2.5 A. peak 20 VA with two scanners & remote meter	
Flame Relay Output:	(At 230V, 50 Hz) (DPDT) Terminals 10, 11, 12 - 125 VA Pilot Duty Terminals 7, 8, 9 - 125 VA Pilot Duty	
Storage Temperature:	- 40° C (- 40° F) Min.	85° C (185° F) Max.
Operating Temperature:	0° C (32° F) Min.	60° C (140° F) Max.
Humidity:	Note: Check scanner bulletins for operating temp. limits. Max. 85% R.H. (Relative Humidity) Noncondensing.	
IP Rating:	00	To provide protection against electrical and weather hazards a suitable electrical cabinet is recommended.
	20	Order dust cover Part Number 60-2223 to upgrade IP rating to 20.
Shutter Cycle Time:	.5 Sec. Closed. 4.5 Sec. Open.	
Scanners:	45RM1, 45RM2, 45RM4, 45FS1, 45UVFS1, 45UV5-1101, 45UV5-1010, 45UV5-1000	
Shipping Weights:	25SU3-5166/5168	2.7 Kg (6 lb.)
	60-2206-2 Wiring Base	1.0 Kg (2 lb.)
	60-2060-17 Adapter	1.4 Kg (3 lb.)
	60-2203-2 Chassis	1.8 Kg (4 lb.)
	60-2205 Display Module	.2 Kg (.5 lb.)
	60-2207-2 Amplifier	.2 Kg (.5 lb.)
	60-2207-1 Amplifier	.2 Kg (.5 lb.)



COMPONENT PARTS

The 25SU3-5166/5168 controls include:

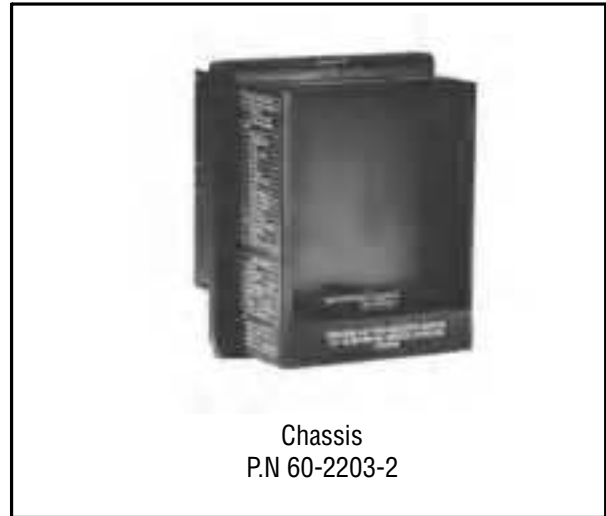



ORDERING INFORMATION

Control consists of the following parts assembled:

25SU3-5166

60-2203-2 Chassis
60-2223 Dust Cover
60-2207- 2 Amplifier, high discrimination
60-2301 Blank Display Module
48-1805 Mounting Screw

25SU3-5168

60-2203-2 Chassis
60-2223 Dust Cover
60-2207-1 Amplifier, high sensitivity
60-2301 Blank Display Module
48-1805 Mounting Screw



INSTALLATION



WARNING: Installer must be a trained safety control technician.

WARNING: Verify that electrical power is disconnected before starting installation.

Scanners:

For installation of:

45UV5	see Bulletin CU-22
45RM1 and 45RM2	see Bulletin CU-26
45RM4	see Bulletin CU-31
45FS1	see Bulletin CU-32
45UVFS1	see Bulletin CU-32
Fiber Optic Scanners	see Bulletin CU-21

25SU3-5166/5168 Control:

For installation of the 25SU3-5166/5168 control using the 60-2206-2 wiring base, refer to page 7 for detailed wiring information. Using the dimension drawings of the wiring base found on page 15, mount the wiring base on an upright surface that is flat and free from excess vibration and moisture. Mount the control inside an electrical cabinet with proper ventilation.

Prior to plugging the control in the wiring base, check the electrical tabs on the bottom of the chassis. If they are bent out of position, reposition them with your finger so that they are in line at the proper angle as shown in Figure 1.



FIGURE 1.

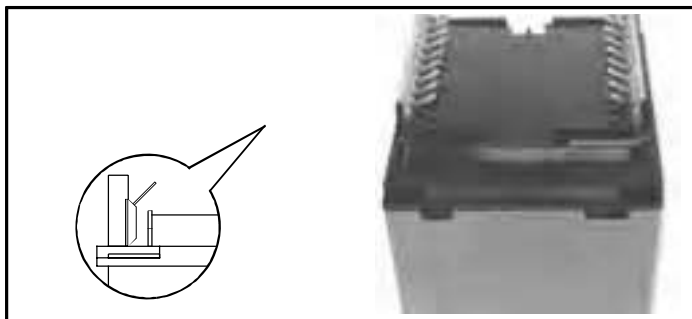

Connect the wiring base ribbon cable to the chassis and plug connection in the wiring base. Refer to Figure 2.

FIGURE 2.



Install the chassis into the wiring base by aligning the two metal tabs on the wiring base with the cut-outs in the chassis. Connect the chassis to the wiring base using the chassis mounting screw. Make sure that the mounting screw is fully tightened so that the chassis seats completely onto the wiring base.

CONTROL AND SCANNER WIRING

The following wiring diagrams depict terminals found on the wiring base. Insulated wire lugs are recommended when connecting wires to screw terminals. All wiring should be enclosed in an approved raceway and must comply with the applicable local codes. Splices should be made in junction boxes.



It is important that cross phasing be prevented on multi phase installations. The common of all control components (magnetic starter coil, ignition transformer, pilot and main fuel valves, etc.) powered by the 5166/5168 control must be connected to the common of the control, terminal 2.

Scanner wiring should be run in conduit. Use shielded wire for connection to terminal 14 and connect the shield to terminal C/13 at the control end only. The shield at the scanner end should be taped and un-connected to any terminal.

All wiring to the scanner should be rated at 600 volts and 90° C. For runs less than 1000 feet, use Fireeye scanner cable **59-470** (four #18AWG wires, two #22 AWG wires with overall shield) or **59-471** (four #18 AWG wires, four #22 AWG wires with overall shield). For runs greater than 1,000 feet, consult factory.

Scanner wiring should be run in separate conduit and away from all other power wiring.



Caution: When a Fireeye Type 45RM Series or 45FS Series scanner is used in parallel with a Fireeye UV scanner, a blocking diode must be used. Fireeye part #101-78 blocking diode should be connected in series with the lead from terminal 14 to the UV scanner as shown in the wiring diagram on page 7. This diode is used to avoid overloading of the 45RM scanner output circuit. If two UV scanners are used, the diode indicated is not required.



Internal Wiring/Functions Amplifier Module 60-2207-2 and 60-2207-1

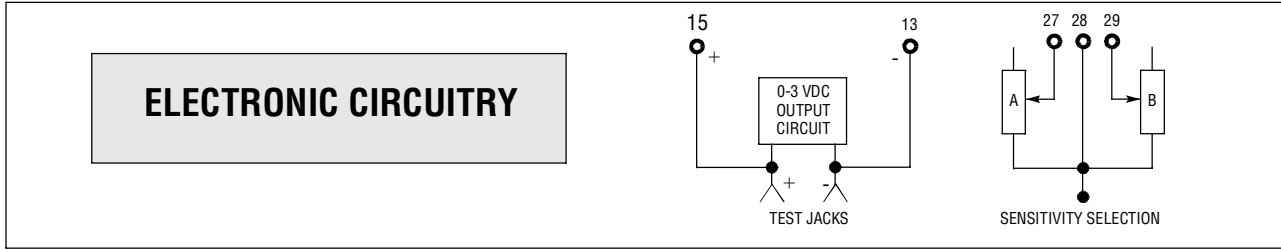

Internal Wiring/Functions Chassis 60-2203-2

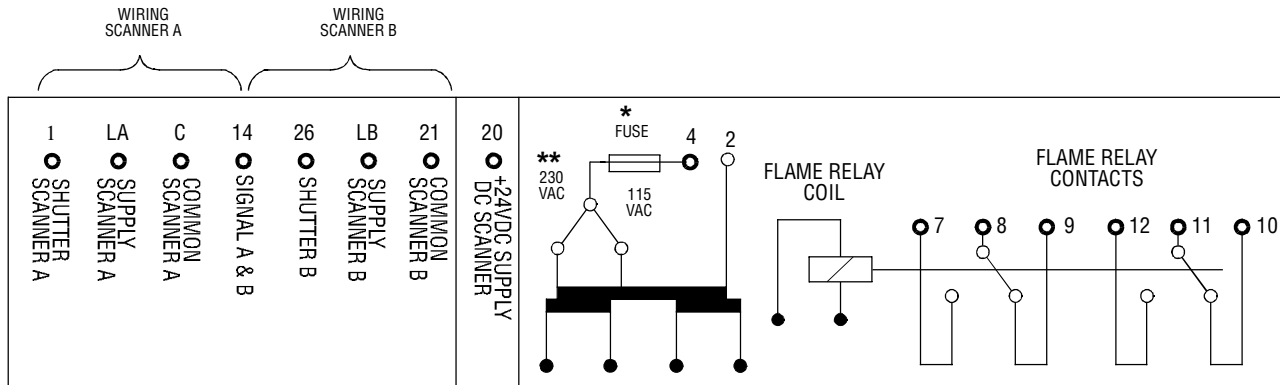

WIRING DC SCANNER(S)
SEE NOTE -- ON PAGE 8

Note: All numbered terminals shown are found on the wiring base P/N 60-2206-2.
**

CAUTION: SEVERE DAMAGE TO THE CONTROL WILL RESULT IF 230 VAC LINE VOLTAGE IS APPLIED WHEN THE VOLTAGE SELECT SWITCH IS IN THE 115 VAC POSITION.

CAUTION: SET SELECTOR SWITCH ON REAR OF CHASSIS TO PROPER VOLTAGE (115 VAC OR 230 VAC) BEFORE APPLYING POWER.



* 1 A. Replaceable Fuse



Switch Shown in 115 VAC Position



Switch Shown in 230 VAC Position



FIGURE 3. Typical Diagram of Type 25SU3 Model 5166 or 25SU3 Model 5168 External Connections

WARNING: System arrangement shown should not be used in lieu of applicable codes.

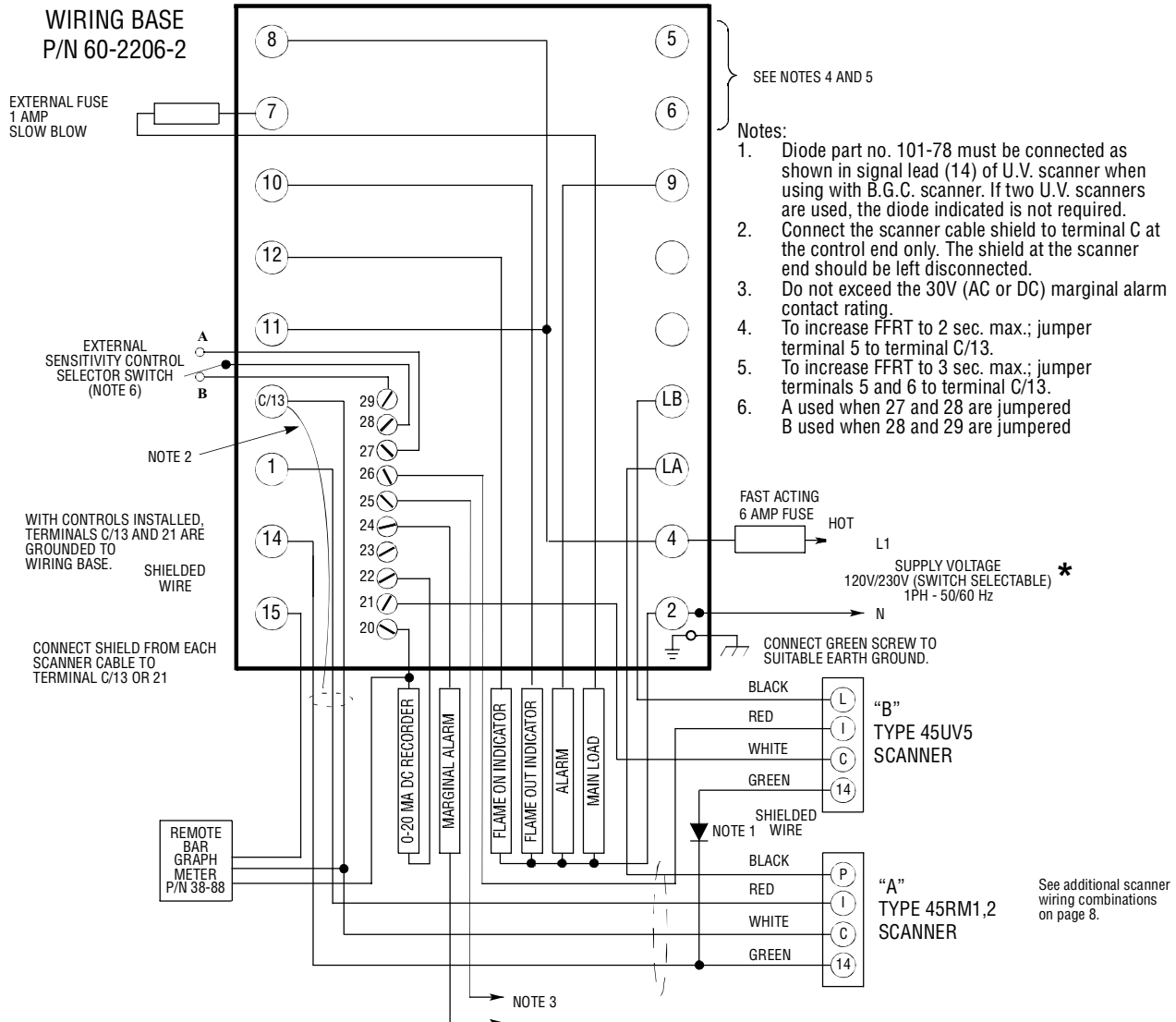

*** IMPORTANT: SET SELECTOR SWITCH ON REAR OF CHASSIS TO PROPER POSITION (115 V OR 230 V) BEFORE APPLYING POWER.**

TERMINAL	DESCRIPTION	TERMINAL	DESCRIPTION
1	SCANNER SHUTTER #1	14	SCANNER(S) SIGNAL
2	SUPPLY VOLTAGE 120 OR 230VAC (CHECK VOLTAGE SELECTOR SWITCH ON REAR OF CHASSIS)	15	FLAME SIGNAL METER (POSITIVE)
4	SUPPLY VOLTAGE 120 OR 230VAC (CHECK VOLTAGE SELECTOR SWITCH ON REAR OF CHASSIS)	LA	SCANNER #1 SUPPLY
5	IF JUMPERED TO TERMINAL C/13, FFRT BECOMES 2S. AND	LB	SCANNER #2 SUPPLY
6	IF JUMPERED TO TERMINAL C/13, FFRT BECOMES 3S.	20	+24VDC FOR DC SCANNERS AND 0-20MA OUTPUT CIRCUIT (POSITIVE)
7	#1 NORMALLY OPEN CONTACT-FLAME RELAY	21	CIRCUIT COMMON (SAME AS C/13)
8	#1 FLAME RELAY COMMON	22	0-20MA OUTPUT CIRCUIT (NEGATIVE)
9	#1 NORMALLY CLOSED CONTACT-FLAME RELAY	23	NORMALLY OPEN CONTACT MARGINAL ALARM RELAY
10	#2 NORMALLY CLOSED CONTACT-FLAME RELAY	24	NORMALLY CLOSED CONTACT MARGINAL ALARM RELAY
11	#2 FLAME RELAY COMMON	25	COMMON MARGINAL ALARM RELAY
12	#2 NORMALLY OPEN CONTACT-FLAME RELAY C	26	SHUTTER SCANNER #2
13	CIRCUIT COMMON (SAME AS 21)	27	SENSITIVITY A SELECTED IF JUMPERED TO TERMINAL 28
		28	COMMON SENSITIVITY SELECTION
		29	SENSITIVITY B SELECTED IF JUMPERED TO TERMINAL 28



FIGURE 4. 25SU3-5166 or 25SU3-5168 Flame Safeguard Control Scanner(s) Wiring Combinations (see note 2)

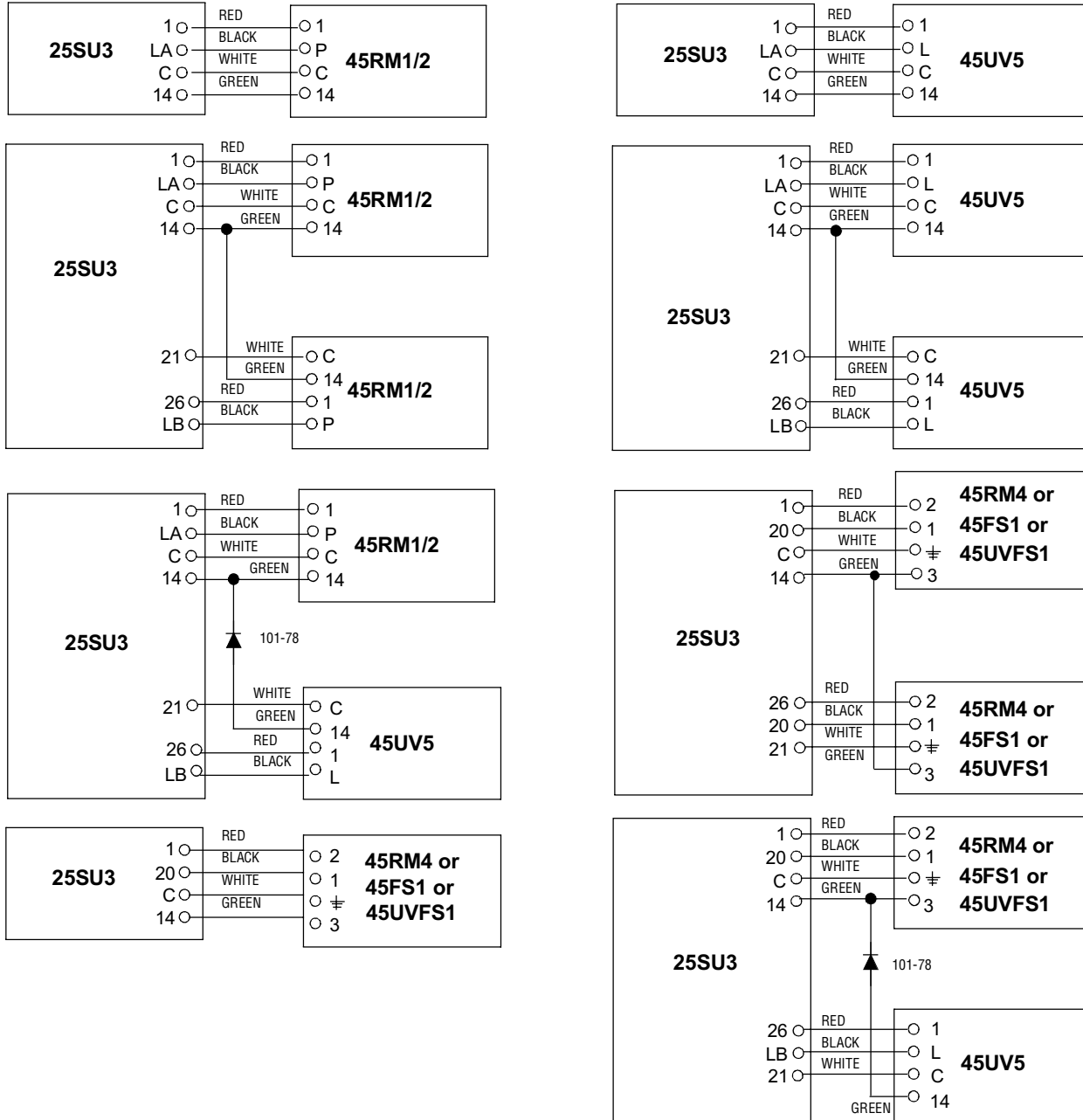

IMPORTANT:
The self-check shutter mechanism only operates when the scanner detects a flame.

IMPORTANT: WHEN USING 45RM4, 45FS1, or 45UVFS1 SCANNER, CONNECT BLACK WIRE (PIN #1 ON CONNECTOR) ON THE SCANNER TO TERMINAL "20" ON THE 60-2206-1 WIRING BASE. DO NOT CONNECT TO "LA" OR "LB."

CAUTION: TWO SCANNERS SHOULD NEVER BE WIRED IN PARALLEL.

- Note 1:** Diode part No. 101-78 must be connected as shown in signal lead (14) of the 45UV5 scanner when using with a 45RM, 45FS, or 45UVFS scanner.
- Note 2:** Scanner cable shield is not shown. Connect cable shield(s) to wiring base terminal C. Refer to appropriate scanner bulletin regarding termination of the shield at the scanner end.
- Note 3:** The scanner wiring shown applies to control wiring base P/N 60-2206-2 only. If Modernization Adapter P/N 60-2060-17 is used, only one line voltage scanner (45UV5, 45RM1, 45RM2) may be connected at one time. Refer to bulletin CX-743E for additional information.



Setup and Adjustment with Fireye 45UV5-1000, 1010, 1101 Scanners

U-V eye scanners have a UV detector tube that may be placed in one of four different positions. The scanners are shipped with the tube set in the maximum sensitivity position. Aim the scanner at the base of the flame as described in Bulletin CU-22.

Setup and Adjustment with Fireye 45RM1 and 45RM2 Scanners

BGC scanners have a sensitivity pot located under the screw on the rear of the scanner housing. Turn it clockwise (maximum) and aim at the base of the flame as described in Bulletin CU-26.

Setup and Adjustment with Fireye 45RM4, 45FS1, and 45UVFS1 Scanners

Refer to Bulletin CU-31 (45RM4) or CU-32 (45FS1/45UVFS1) for setup.

Testing and Adjustment Procedure

1. Turn the sensitivity to maximum.
2. Plug a meter into the (+) and (—) test jacks on the Flame Amplifier Module or connect at terminals C/13 (—) and 15 (+).
3. Establish the flame at the operating level.
4. While aiming the scanner, it may be helpful to disconnect the shutter drive(s) so there will be a continuous signal.
5. Adjust the alignment of the scanner to achieve the highest flame signal strength, usually the first 1/3 of the flame.
6. Turn off the burner being supervised.
7. Verify that the flame signal drops below the flame relay's drop-out threshold, (refer to figure below), and that the flame relay de-energizes. In multi-burner applications, this test must be performed with the other burners firing.
8. Eliminate any unwanted flame signal by reducing the 25SU3 sensitivity, by re-aligning the scanner, by reducing the scanner's field of view with a sight pipe orifice, or by a combination of these methods.
9. Repeat steps 3 through 9 until reliable operation is achieved.

FIGURE 5. FLAME RESPONSE CURVES (shown with sensitivity set @ maximum)

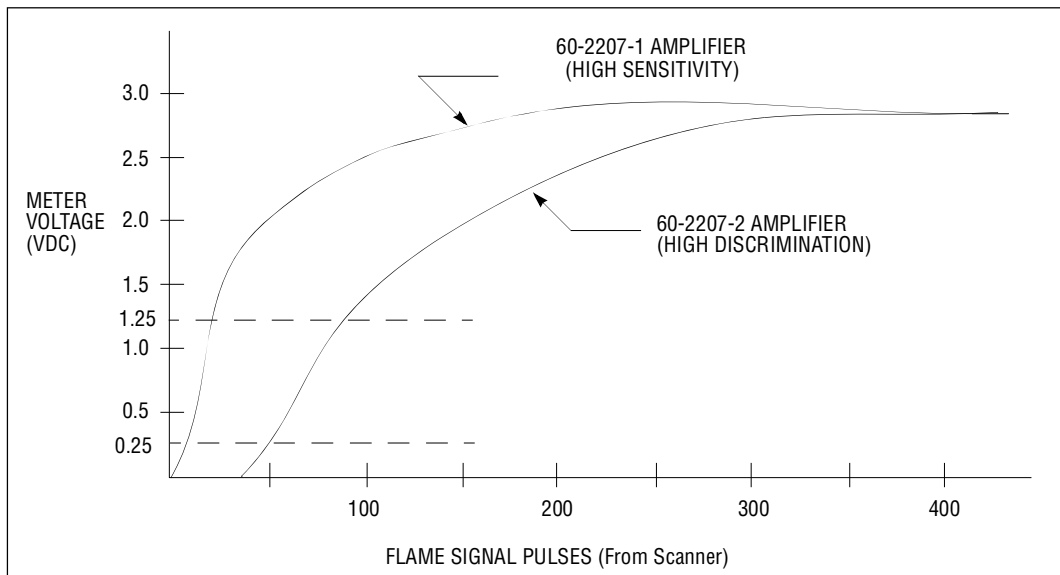



METER/TEST JACK VOLTAGE

FLAME RELAY	60-2207-1	60-2207-2
Pull-In	1.25	0.80
Drop-Out	1.00	0.25

Note: The pull-in and drop-out voltage are nominal and for reference only. The actual value may vary.

OPERATION

The 25SU3 Model 5166/5168 control detects flame using a Fireeye infrared or ultraviolet scanner. When flame is detected by the scanner, a pulse train is generated and transmitted to the 5166 control through the scanner wiring cable. Pulses are modified by a pulse shaping circuit in the amplifier and regulated by operator adjustment of the sensitivity potentiometer. An increase in the sensitivity adjustment will provide an increase in the signal level to an output relay comparator. If the signal to the relay is greater than the comparator threshold, the flame relay will energize.

If the flame signal drops below the flame relay threshold (or is absent) for a period longer than the selected flame failure response time (FFRT), the flame relay will drop out.



Warning: The flame relay contact should be wired in to the burner management system in such a manner as to provide manual start-up sequencing and automatic burner shutdown as appropriate.

The flame failure response time (FFRT) remains constant regardless of the flame intensity prior to flame out.

Sensitivity adjustment of the control is performed by the use of two potentiometers found on the face of the flame amplifier module. These adjustments are marked "Sensitivity A" and "Sensitivity B" as shown on Figure 3. Flame amplifier module #60-2207-2 or 60-2207-1 can accommodate the use of two scanners. Sensitivity A and B can be selected through the use of an external selector switch connected to terminals 27, 28, and 29. Note the wiring diagram on page 7. If Sensitivity A only is to be used, terminals 27 and 28 should be jumpered together. For Sensitivity B only, terminals 28 and 29 should be jumpered together.

FIGURE 6.



An indication of flame signal strength can be obtained using a remote meter (see Accessories on Page 14) or a 20,000 ohm per volt voltmeter on a 3 volt DC scale. Wire to the test jack terminals found on the face of the flame amplifier module or to terminals 15 and C/13.



Each sensitivity adjustment is used for regulating the signal level in excess of the flame relay threshold. Turning the sensitivity in the clockwise direction amplifies the flame signal. The sensitivity must be set so that the monitored burner produces a reading greater than the Flame Relay "Pull-In" voltage as read across the test jacks found on the face of the amplifier or terminals 15 and C/13.

With flame not present at the monitored burner, the flame from other burners and/or radiation from hot refractory should yield a reading lower than the Flame Relay "Drop-Out" voltage. If the flame signal does not drop sufficiently when the flame from the monitored burner is turned off, decrease the sensitivity. If decreasing the sensitivity results in an insufficient meter reading when flame is present, resight the scanner to detect more of the flame being monitored.

Normally, the flame signal can be adjusted for a reading of 2 volts and the control will be capable of detecting a flame failure in the presence of background radiation and adjacent burner flames. Discrimination between burner flames is best with a reading below the saturation level of 2.85 volts.

Note: Sensitivity settings do not affect the flame failure response time (FFRT). The flame relay (RF) is a DC powered flame proving relay with its contacts shown in the electrical diagram found on page 6. This relay will be energized when the control is powered and flame signal greater than the flame relay threshold is being received.

The flame relay automatically de-energizes if any of the following conditions occur:

1. No flame signal within the selected FFRT.
2. A flame signal level below the flame relay threshold for the FFRT.
3. A scanner failure or electronic circuit failure is detected.

The Fireye 5166/5168 control provides repeated self-checking of both the scanner and control amplifier approximately 12 times per minute. This feature reduces the risk associated with component failure of the types which would otherwise generate a "flame on" response. This is especially valuable when extended firing periods occur. When the control fails to detect signal loss for three consecutive shutter cycles, the flame relay is de-energized.

MAINTENANCE

Humidity Effects: It is considered good practice to minimize any possible adverse effects of high humidity by keeping electronic equipment continuously powered, even during periods when it is not in use.

Scanner: If continuous air purging of the scanner sight pipe is not completely effective in preventing viewing window contamination, a schedule should be set up for periodically cleaning the window. Always use a soft, clean (non-oily) cloth to wipe the window. For maximum assurance that oily films will be removed, wash first with a cloth dampened (not dripping) with a concentrated detergent solution.



Warning: Disconnect or shut off electric power when working on scanner.

Notice: When Fireye products are combined with equipment manufactured by others and/or integrated into systems designed or manufactured by others, Fireye's warranty, as stated in its General Terms and Conditions of Sale, pertains only to the Fireye products and not to any other equipment or to the combined system or its overall performance.



FIGURE 7. Agency Approvals

Type	Model	FM	Underwriters Laboratories	CSA	APAVE	DVGW	DIN
25SU3	5166				√	√	√
25SU3	5168						
45UV5	1000	√	√	√			
	1010		√				
	1101	√			√	√	√
45RM1	1001	√		√			
	1003	√			√	√	√
	1005	√					
45RM2	1000	√		√			
	1001	√			√	√	√
	1002	√					
45RM4	1000	√					
	1001	√		√		√	√
45FS1	1000	√					
	1001						
45UVFS1	1000	√		√			
	1001	√		√			

ACCESSORIES

Wiring Base (P/N 60-2206-2)



The wiring base is used to terminate all wires to the control. It should be mounted on a smooth, secure surface capable of supporting the base and control. The chassis and control assembly mounts into the wiring base and is secured using the single mounting screw. The ribbon cable included with the base should be plugged into the lower left corner of the chassis.

Display Module (P/N 60-2205)



An optional LED display module can be inserted in place of the blank display module. It contains a bright red LED display of flame signal strength, a flame relay indication LED, and a marginal alarm relay with setpoint adjustment.

Caution: Do not exceed the 30V (AC or DC) marginal alarm relay contact rating.



Display Module Functions:

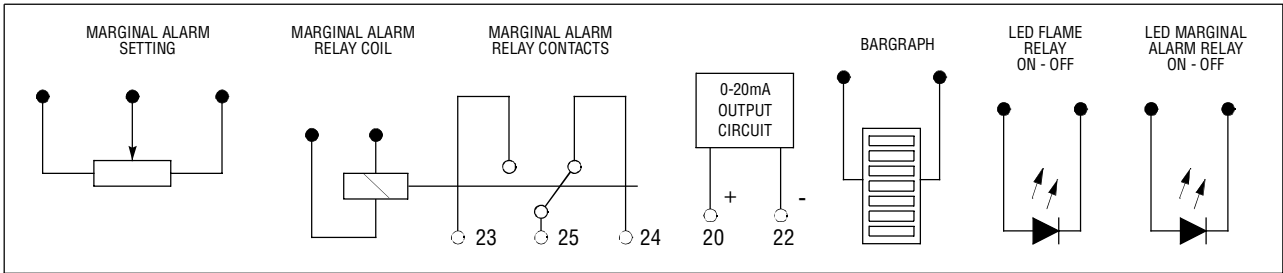

Remove the Blank Display Module from the chassis slot marked “Display Module” and replace with the Display Module, Fireye P/N 60-2205, shown above.

The bar graph meter found on the 60-2205 display contains a vertical scale having ten light emitting diodes (LED’S) number 1 through 10.

Highest LED Lit	Flame Signal Intensity Volts DC
10	3.0
9	2.7
8	2.4
7	2.1
6	1.8
5	1.5
4	1.2
3	.9
2	.6
1	.3

Note: The bar graph indicator will normally decrease by one to two bars when the scanner shutter cycles.

Marginal Alarm with LED

The Display Module is equipped with a Marginal Alarm Relay (RA) having dry contacts brought out on terminals shown on page 7 in the wiring diagram. This relay is energized only if:

1. The Flame Relay is energized and
2. The Flame Signal is greater than the Marginal Alarm Relay setpoint.

The Marginal Alarm Relay setpoint is adjustable via the LED/potentiometer located on the Display Module. If the flame signal becomes marginal for more than 30 seconds, as might be caused by dirt on the scanner lens, etc., the Marginal Alarm Relay will drop out to sound an external alarm (not provided) and illuminate its LED setpoint potentiometer.

Note: The Marginal Alarm setpoint should be set high enough to allow for corrective action, not too high such that nuisance trips occur. The Marginal Alarm will automatically reset when the flame signal intensity is greater than the setpoint.

Caution: Do not exceed the 30V Marginal Alarm contact rating. AC or DC voltage may be used. Do not use contacts for safety relevant function.



Diagnostic Flame Relay LED

This LED is illuminated when the flame signal is greater than the Flame Relay threshold. The LED may also be used in diagnosing a malfunctioning UV tube and/or shutter failed open evidenced by the following:

1. Flame relay LED "Lit" and
2. Remote Flame Out Indicator (terminal 10, Flame Relay deenergized).

Modernization Adapter (P/N 60-2060-17)



When replacing an existing Fireye Control Type 25S3-4157(T), - 4158(T), - 4166, 25SU5 - 4112T, -4111T, or -4117, you can use this modernization adapter to avoid complete system rewiring. Refer to Bulletin CX-743E for more details concerning the conversion.

Meters

Five styles of remote analog meters are available for use with the Type 25SU3 Model 5166/5168 Controls:

P/N	Description	Input/Scale	Size
38-54	Panel Meter	0-3 VDC 0-64	2-3/8" (60.3) sq.
38-55	Panel Meter	0-3 VDC 0-64	1-1/4" (31.8) x 3" (76.2) hrz.
38-56	Panel Meter	0-3 VDC 0-64	1-1/4" (31.8) x 3" (76.2) vrt.
38-62	Panel Meter	0-3 VDC 0-64	1/2" (12.7) x 1-5/8" (41.3) hrz.
38-88	Analog Bar Graph Meter (LED)	0-3 VDC 0-0 (10)	1.00" (25.4) v 2.2" (55.9) vrt. 3.06 (77.7) depth



Control, Wiring Base and Scanner Dimensions

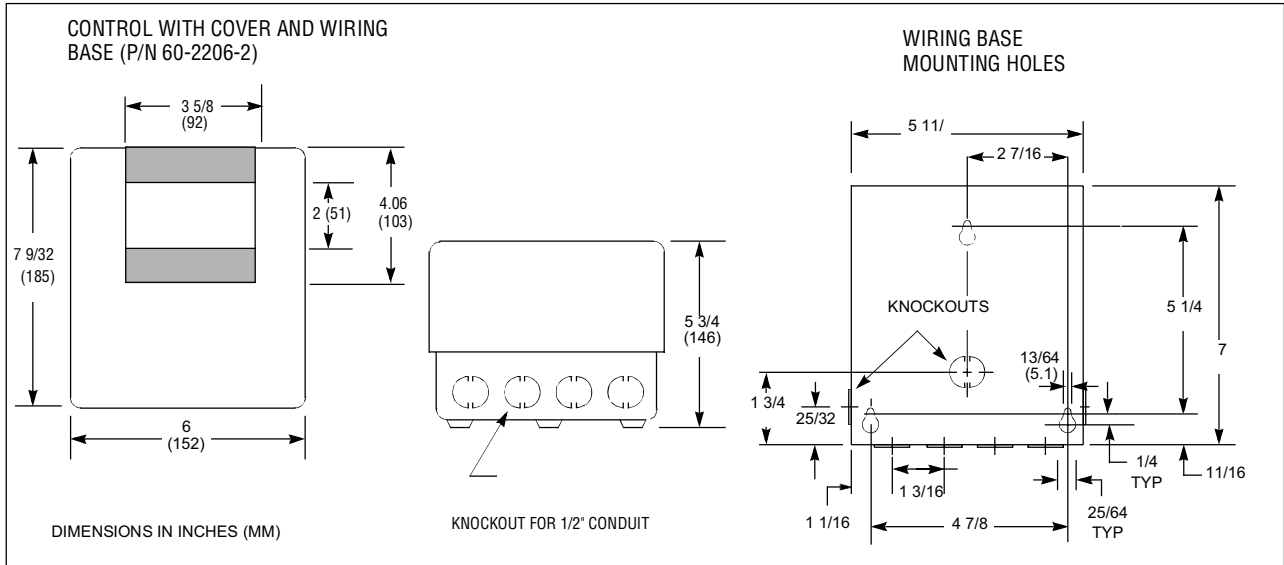

SCANNER TYPE 45UV5

2" (51)
CLEARANCE
REQUIRED
TO REMOVE

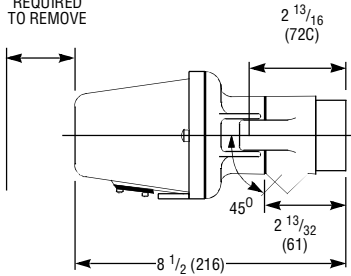

- Notes:
1. Housing may be rotated with respect to hinge position in 90° increments.
 2. Material - Aluminum

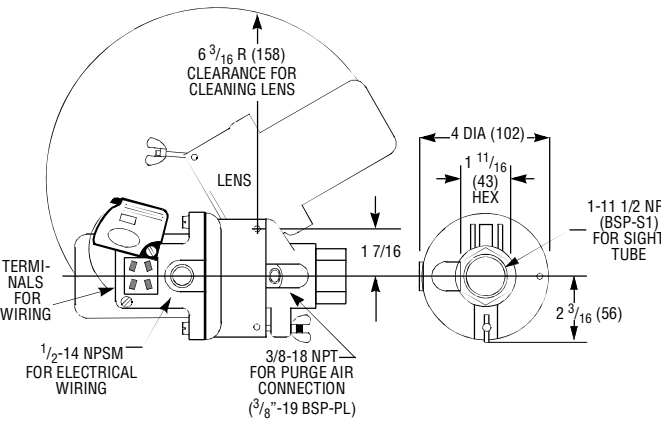

SCANNER TYPE 45RM1, 45RM2, 45RM4, 45FS1, 45UVFS1

Notes:

2" (51)
CLEARANCE
REQUIRED
TO REMOVE

1. Housing Material - Aluminum
2. Shown without fiber optics. See Bulletin CU-21. 45RM4, 45FS1, 45UVFS1 have quick disconnect.

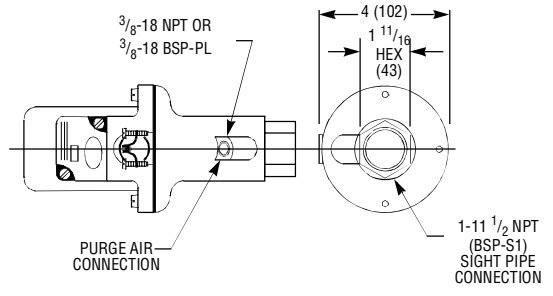
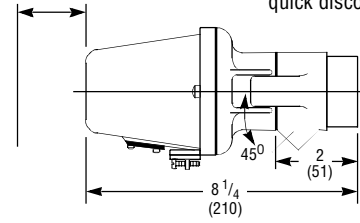



NOTICE

When Fireeye products are combined with equipment manufactured by others and/or integrated into systems designed or manufactured by others, the Fireeye warranty, as stated in its General Terms and Conditions of Sale, pertains only to the Fireeye products and not to any other equipment or to the combined system or its overall performance.

WARRANTIES

FIREYE guarantees for *one year from the date of installation or 18 months from date of manufacture* of its products to replace, or, at its option, to repair any product or part thereof (except lamps, electronic tubes and photocells) which is found defective in material or workmanship or which otherwise fails to conform to the description of the product on the face of its sales order. **THE FOREGOING IS IN LIEU OF ALL OTHER WARRANTIES AND FIREYE MAKES NO WARRANTY OF MERCHANTABILITY OR ANY OTHER WARRANTY, EXPRESS OR IMPLIED.** Except as specifically stated in these general terms and conditions of sale, remedies with respect to any product or part number manufactured or sold by Fireeye shall be limited exclusively to the right to replacement or repair as above provided. In no event shall Fireeye be liable for consequential or special damages of any nature that may arise in connection with such product or part.



FIREYE INC.®
3 Manchester Road
Derry, New Hampshire 03038 USA
www.fireeye.com

CX-742E
AUGUST 10, 2005
Supersedes Sept. 2001

