



— MODEL — **92-01/692-01**
**Combination Pressure Reducing and
 Pressure Sustaining Valve**

INTRODUCTION

The Cla-Val 92-01/692-01 is an automatic valve designed to maintain a constant downstream pressure regardless of fluctuating demand and sustain the upstream pressure to a predetermined minimum. The control system consists of a reducing control sensing downstream pressure changes and a pressure sustaining control that is sensing the main valve inlet. The pressure reducing control responds to slight downstream variations in pressure and immediately controls the main valve to maintain the desired downstream pressure. The pressure sustaining control is normally held open by the upstream pressure but closes if this pressure drops to the control set point. This in turn closes the main valve to sustain the desired upstream pressure.

INSTALLATION

1. Allow sufficient room around the valve assembly to make adjustments and for disassembly.

2. It is recommended that gate or block valves be installed on both ends of the 92-01/692-01 valve assembly to facilitate isolating the valve for maintenance.

NOTE: BEFORE THE VALVE IS INSTALLED, PIPE LINES SHOULD BE FLUSHED OF ALL CHIPS, SCALE, AND FOREIGN MATTER.

3. Place valve assembly in pipe line with flow through valve in direction indicated on inlet plate or by flow arrows. Check all fittings and hardware for proper makeup and that no apparent damage is evident.

4. Cla-Val Valves operate with maximum efficiency when mounted in horizontal piping with the cover UP; however, other positions are acceptable. Due to size and weight of cover and internal components of six inch and larger valves installation with the cover up is advisable. This makes periodic inspection of internal parts readily accessible.

5. Caution must be taken in the installation of this valve to insure that galvanic and/or electrolytic action does not take place. The proper use of dielectric fittings and gaskets are required in all systems using dissimilar metals.

OPERATION AND START-UP

1. Prior to pressurizing the valve make sure necessary gauges to measure pressure in the system are installed as required by the system engineer. A Cla-Val X101 Valve Position Indicator may be installed in the center cover port to provide a visual indication of the valve stem position during start-up adjustments.

CAUTION: During start-up and test a large volume of water may be discharged downstream. Check that the downstream venting is adequate to prevent damage to personnel and equipment. All adjustments in pressure should be made slowly. If the main valve closes too fast it may cause surging in upstream piping.

2. If isolation valves (B) are installed in pilot system open these valves (see schematic).

3. Remove cap on the CRL Pressure Relief Control (4). Loosen jam nut and turn adjusting screw counter clockwise. This puts the CRL in an open position.

4. Cla-Val CV Flow Control (5 & C) provide adjustable regulation of flow in and out of the main valve chamber which minimizes pulsations that sometimes occur at very low flow rates. Loosen jam nuts and turn adjustment screws counterclockwise from closed position 3.5 turns for an initial setting.

5. Open the upstream gate or block valve just slightly to allow the valve assembly and pilot system to fill with liquid.

6. Carefully loosen tube fittings at highest points and bleed air from system. Carefully loosen the plug at top of main valve cover. If X101 indicator is installed, carefully open vent valve at top of Indicator. Bleed air from cover and tighten plug. Tighten tube fittings.

7. Open the upstream gate or block valve fully.

8. Slowly open the downstream gate or block valve. Flow should occur and pressure should remain constant.

9. Adjust the CRD Control (3) to desired outlet pressure. To change pressure setting, turn the adjusting screw clockwise to increase pressure, counterclockwise to decrease pressure: There should be flow through the valve when adjusting pressure. When the desired setting has been made, tighten jam nut and replace cover. An increase in pressure at the outlet will tend to close the CRD Control and main valve. This action causes the main valve with CV control (5 or C) to modulate (open and close) maintaining a relatively constant outlet pressure.

10. Adjust the CRL Control (4) to maintain the desired minimum inlet or upstream pressure. To change pressure setting, turn the adjusting screw clockwise to increase the inlet pressure, counterclockwise to decrease pressure. When the desired setting has been made, tighten jam nut and replace cover. A decrease in inlet pressure below the set pressure of the CRL closes the control and main valve. The main valve will modulate to maintain the upstream pressure at the set point of CRL.

11. To check the operation of the pressure reducing and pressure sustaining features of the valve assembly, induce pressure changes at the valve inlet and outlet.

12. Fine-tune the opening and closing speed of the main valve with CV control (5 or C) while performing steps 9 and 10.

MAINTENANCE

1. Cla-Val Valves and Controls require no lubrication or packing and a minimum of maintenance. However, a periodic inspection schedule should be established to determine how the fluid handled is affecting the efficiency of the valve assembly. Minimum of once per year.

2. Repair and maintenance procedures of the Cla-Val Hytrol Main Valve and pilot control components are included in a more detailed IOM manual. It can be downloaded from our web site (www.cla-val.com) or obtained by contacting a Cla-Val Regional Sales Office.

3. **When ordering parts always refer to the catalog number and stock number on the valve nameplate.**

| SYMPTOM | PROBABLE CAUSE | REMEDY |
|---------------------------|---|---|
| Main valve fails to open | No pressure at valve inlet Main valve diaphragm assembly inoperative | Check inlet pressure Adjust CRL Disassemble, clean and polish stem, disc guide, replace defective or worn parts |
| | CRD Pressure Reducing Control not opening: 1. No spring compression 2. Damaged spring 3. Spring guide not in place 4. Yoke dragging on inlet nozzle | 1. Tighten adjusting screw 2. Disassemble and replace 3. Assemble properly 4. Assemble properly |
| | CRL Control not opening: 1. Adjusting screw turned in too far (setting too high) 2. Fails to open with spring compression removed 3. Diaphragm damage (leakage from cover vent hole) 4. Loose upper diaphragm washer | 1. Back off adjusting screw reset 2. Disassemble, remove scale, obstruction 3. Disassemble, replace damaged diaphragm 4. Tighten upper diaphragm |
| Main valve fails to close | Foreign matter between disc & seat of main valve, damaged disc, scale on stem or disc guide, diaphragm damaged | Disassemble main valve, remove foreign matter, clean or replace damaged parts |
| | X44A Strainer & orifice clogged. CK2 Shutoff Valve (B2) in control line closed | Remove strainer plug and Clean screen and orifice Open CK2 Valve |
| | CRD Pressure Reducing Control remains open or sluggish: 1. Spring compressed solid 2. Worn or damaged disc 3. Yoke dragging on inlet nozzle 4. CRD diaphragm damaged or loose diaphragm nut (leakage from vent hole in cover) | 1. Back off adjusting screw 2. Disassemble, remove and replace disc retainer assembly 3. Assemble properly 4. Disassemble, tighten diaphragm nut replace diaphragm |
| | CRL Pressure Relief Control fails to close due to lack of spring compression | Turn adjusting screw in clockwise Reset control |
| | A mechanical obstruction holding control open | Disassemble, locate and remove obstruction |

92-01/692-01 SCHEMATIC

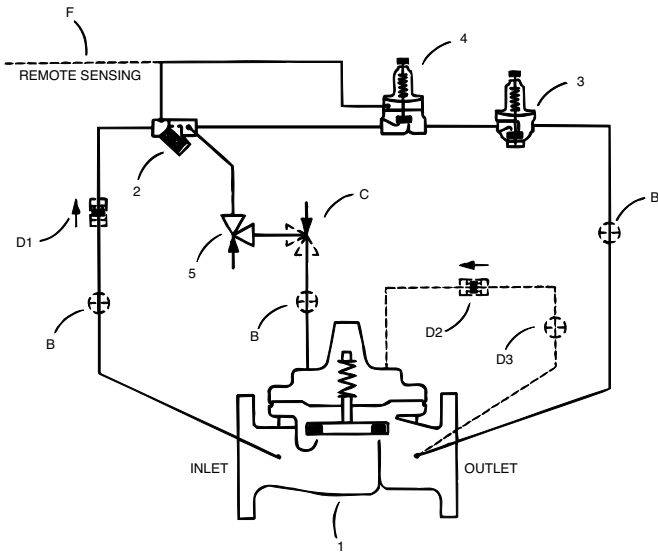

BASIC COMPONENTS

- 1 100-01 Hytrol (Main Valve)
- 100-20 600 Series Hytrol (Main Valve)
- 2 X44A Strainer & Orifice
- 3 CRD Pressure Reducing Control
- 4 CRL Pressure Relief Control
- 5 CV Flow Control - Opening

OPTIONAL FEATURES

- B CK2 (Isolation Valves)
- C CV Flow Control - Closing
- D Check Valves with Isolation Valves
- F Remote Sensing

CRD

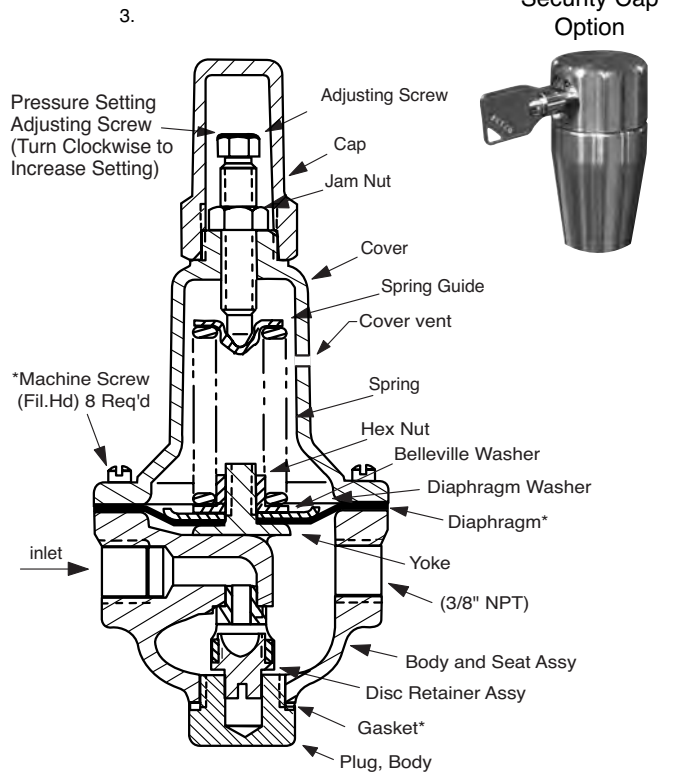

HYTROL MAIN VALVE

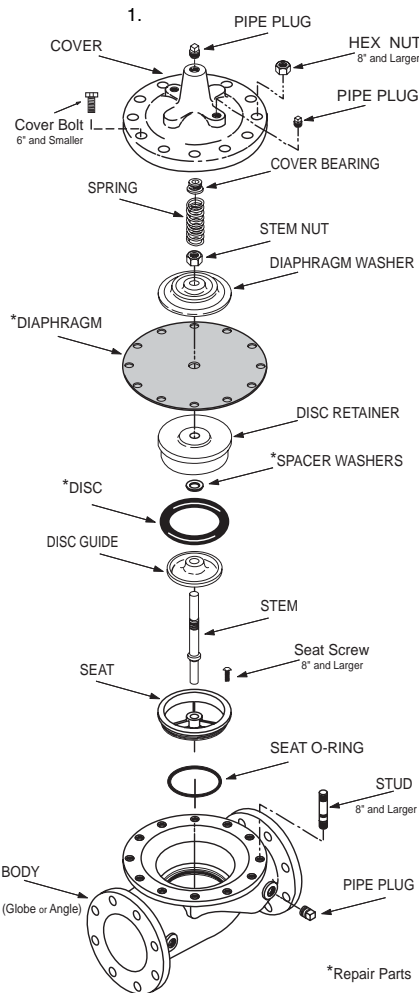

X44A



CRD



CRL



CV



CK2



CDC-1



CRL

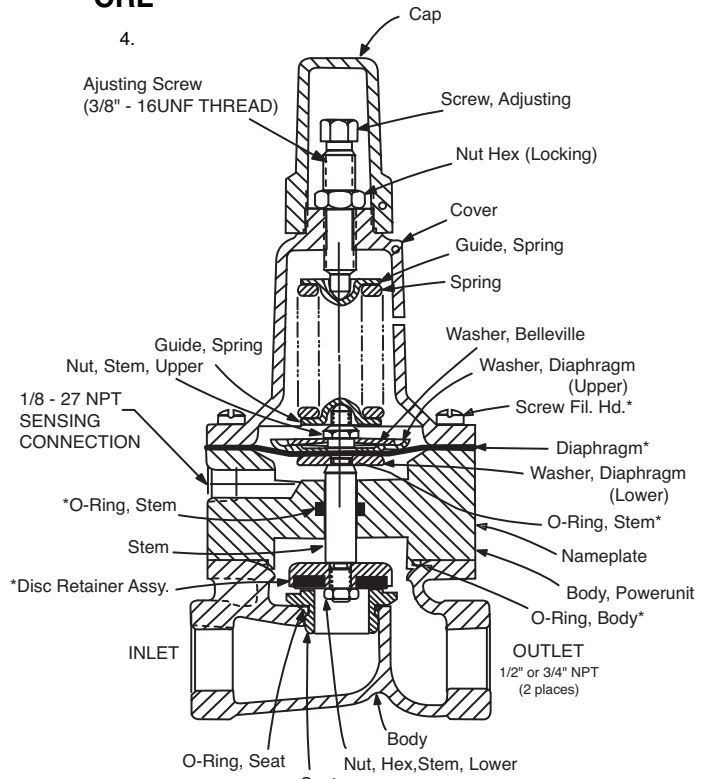

*SUGGESTED REPAIR PARTS

For a more detailed IOM Manual go to www.cla-val.com or contact a Cla-Val Regional Sales Office.