

Specifications

Size 1/2" & 3/4" Threaded NPT
Temperature Range Water, Air: to 180°F Max.
Materials
 Body & Cover: Cast Bronze ASTM B62 Low Lead
 Stainless Steel ASTM A743-CF-16Fa
 Trim: 303 Stainless Steel
 Rubber: Buna-N® Synthetic Rubber

Pressure Ratings Cast Bronze 400 psi Max.
 Stainless Steel 400 psi Max.

Other Materials Available on special order
Adjustment Ranges: UL Listed and FM Approved
 0 to 75 psi
 20 to 200 psi
 100 to 300 psi

UL Listed/FM Approved 55L-60 Range psi	Approximate Increase for Each Clockwise Turn of Adjusting Screw
0 to 75	8.5 psi
20 to 200	28.0 psi
100 to 300	18.0 psi

Pressure Drop Chart (Full Open Valve)

Valve Size	C _v Factor	Flow of Water - Gallons Per Minute				
		5	10	16	20	30
1/2"	6	0.7	2.7	6	11	--
3/4"	8.5	0.3	1.4	3.1	5.5	12.2

	Part Number	Size	Spring Range
1	20881501D	1/2"	0-75
2	20881502C	1/2"	20-200
3	20885301G	1/2"	100-300
4	20881503B	3/4"	0-75
5	20881504A	3/4"	20-200
6	20885302F	3/4"	100-300

* Part #s listed are for Bronze Valves only.
 For Stainless Steel Valve Part #s, please consult factory.

When Ordering, Please Specify

- Catalog No. 55L-60
- Valve Size
- Adjustment Range Required
- Optional Materials

Dimensions: 0 to 75 and 20 to 175 psi design

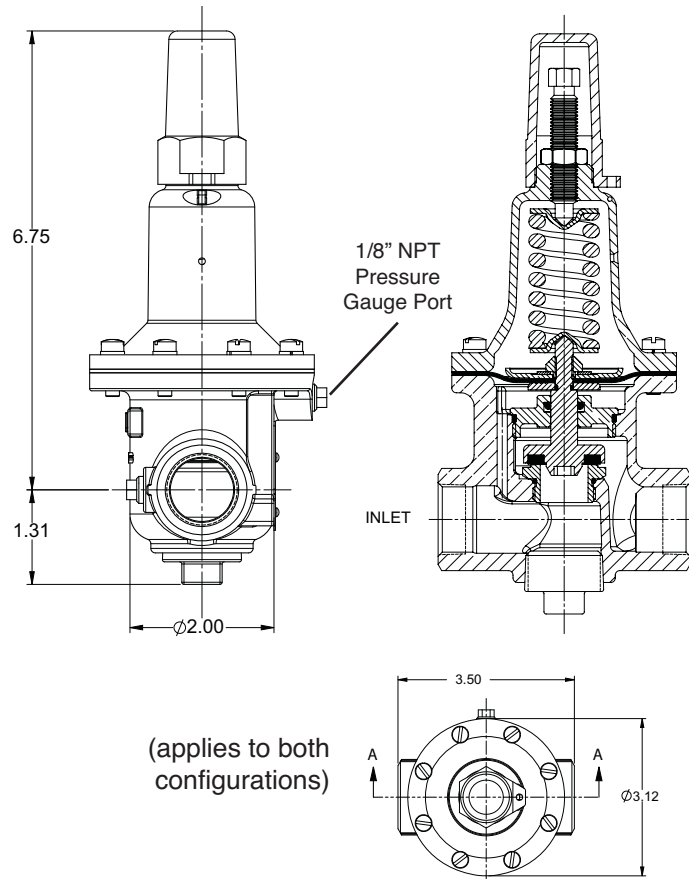

Dimensions: 100 - 300 psi design

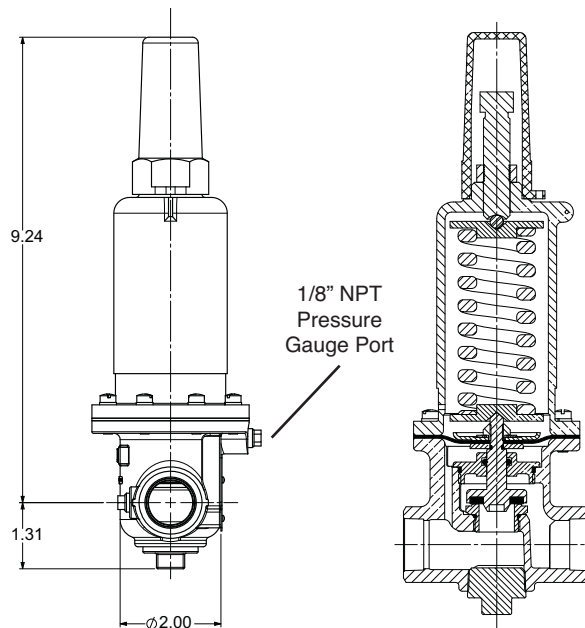

Distributed By:
 M&M Control Service, Inc.
 Phone: 800-876-0036
 Fax: 847-356-0747
 Email: sales@mmcontrol.com