



**Heavy Duty Types –
3" Dial Size**

STANDARD FEATURES

- Shock and Vibration Resistant
- Stainless Steel Construction
- Plastic Crystal
- Dished Anti-Parallax Dial for Easy Reading
- External Recalibration Adjustment at Rear of Case
- Accurate to 1% of Scale Range (when tested without well)
- Interchangeable with 5" Scale Size "Submarine" Thermometers Having Same Stem Length
- 3/4"-28 UN2A Union Connection Assembly Must be used with Well (or Bushing)

STEM LENGTH	CATALOG NUMBERS	
	90° BACK ANGLE FORM	STRAIGHT FORM
2"	H3A2	H3S2
4"	H3A4	H3S4
6"	H3A6	H3S6

NOTE: A minimum of 2" insertion (immersion) is required for accurate readings and proper response.

CODE	Fahrenheit
D	-40 to 120°F in 2° divs.*
H	0 to 200°F in 2° divs.
L	20 to 240°F in 2° divs.
P	50 to 300°F in 2° divs.
Q	50 to 400°F in 5° divs.
R	50 to 500°F in 5° divs.
S	50 to 750°F in 10° divs.

CODE	Celsius
1	-50 to 50°C in 1° divs.*
2	-10 to 110°C in 1° divs.
5	0 to 150°C in 2° divs.
6	0 to 200°C in 2° divs.
8	0 to 300°C in 5° divs.

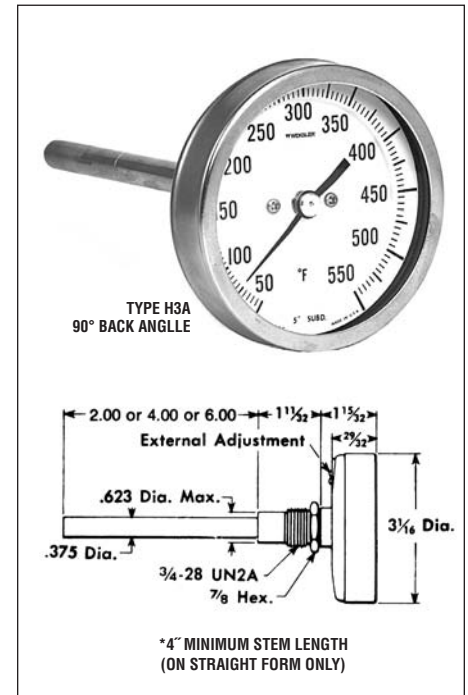

HOW TO ORDER

H 3 S 4 H

1. Basic 4-digit Catalog No. _____
2. Range Code _____

**THERMOWELLS FOR HEAVY DUTY BIMETAL THERMOMETERS
.385" BORE – 3/4-28" FEMALE THREAD (INTERNAL)**

THREADED TYPE – 3/4-14 NPT MALE

THERMOMETER STEM LENGTH	WELL LENGTH (OVERALL)	CATALOG NO.
		304 SS
2"	3 1/4"	W3G1
4"	5 1/4"	W5G1
6"	7 1/4"	W7G1

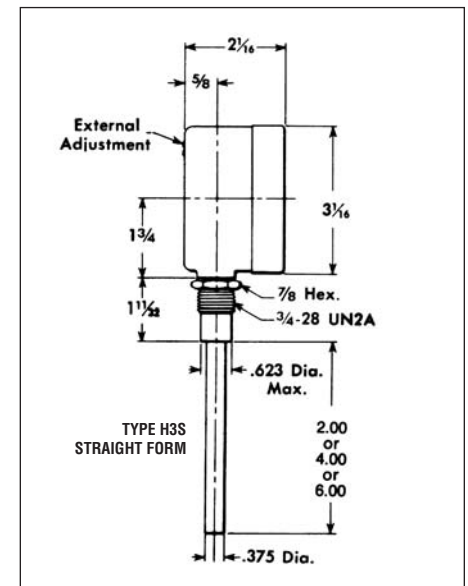
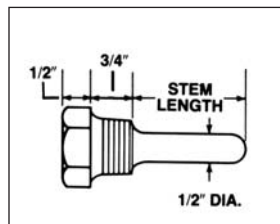

To Order: Specify 4 digit catalog no. from above tables