

# 940E Series Electric Motor Control Valve

CONTROL VALVES



940E-25 shown

▶ Fail Open or Closed

▶ Cast Aluminum Construction

▶ 1/2" – 8" Valve Sizes

The Terice **940E Series** Control Valve uses a 24 Volt power supply (AC or DC) to proportionally stroke the valve via an electric motor drive actuator. The actuator will drive the valve stem up or down (to open or close the valve) in relation to a factory set 2-10 Vdc input signal (field switchable to 4-20 mA) from a controller. These electric motors can be specified to "fail-open" or "fail-closed" should a loss of control signal or actuator supply power occur. Actuators are available in two sizes: "25" for standard applications and "26" which provides for increased close-off capabilities and is required for use on some larger size valves.

**For optimal performance, the service conditions (medium, flow, temperature, inlet and outlet pressures) of the application must be considered when selecting a valve. Please refer to the Valve Selection Section of this catalog. Consult the Valve Selection tables for the capabilities of a particular valve/actuator assembly. Improper application may cause failure of the valve, resulting in possible personal injury or property damage.**

For replacement or service parts please see Accessories and Replacement Parts in the Regulators and Control Valves section of the list price sheet.

## Specifications

**Model**  
940E

### Actuators

25, 26

### Construction

Aluminum Die-Cast Yoke,  
Plastic Housing

### Power Supply

24 VAC,  $\pm 20\%$  50/60 Hz, 21 VA or  
24 Vdc,  $\pm 10\%$ , 21 VA

### Input Signal

2-10 Vdc  
(field switchable to 4-20 mA)

### Fail Position

Stem-Out (open),  
Stem-In (closed)  
  
Manual Over-ride Feature included  
with all models

### Stroke Time (no Load)

Controlled Stroke: 90 seconds  
Fail-Safe Stroke: 35 seconds

### Protection

NEMA 2 (indoor only)

### Maximum Temperature

Ambient: +32 to +122°F (0-50°C)  
Process Flow: See specific valve

### Humidity

Maximum: 95% RH

### Approximate Shipping Weight

#### Actuator:

25: 4.5 lbs [2 kg]  
26: 8.5 lbs [3.9 kg]

#### Valve Body:

see Valve Selection tables

## HOW TO ORDER

Sample Order Number: **940E-25-J36-17**

Model	Actuator Size	Valve Body Number	Power Supply	Fail Position
940E	25 26	Refer to pages 260-268	1 24 VAC/Vdc (universal)	6 Stem-Out (open) 7 Stem-In (closed)

- Determine** the valve size, style and material required by the application.
- Consult** the Valve Selection table to determine the required Valve Body.
- Refer** to the maximum close-off pressure columns to determine the Actuator Size needed to provide the close-off pressure required by your application.
- Specify** the Model and Actuator Size.
- Specify** the Valve Body Number.
- Specify** the Power Supply and Fail Position codes.

# 940E Series

## Electric Motor Control Valve

All dimensions are nominal. Dimensions in [ ] are in millimeters.

### Actuator Size 25

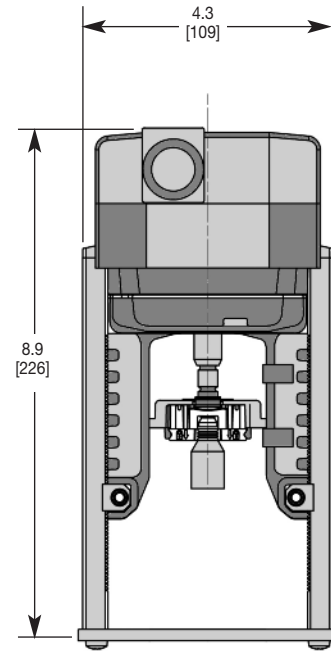
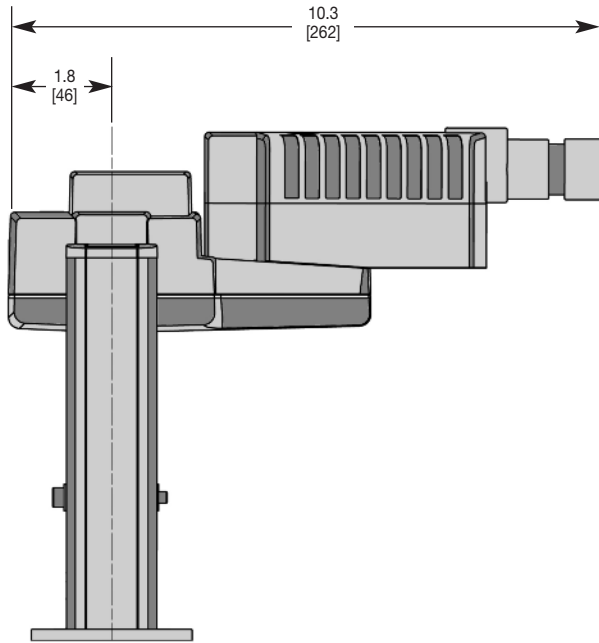

CONTROL VALVES

### Actuator Size 26

