

# Thermowells

## for Dial Thermometers

All dimensions are nominal.  
Dimensions in [ ] are in millimeters.

THERMOWELLS

### Standard

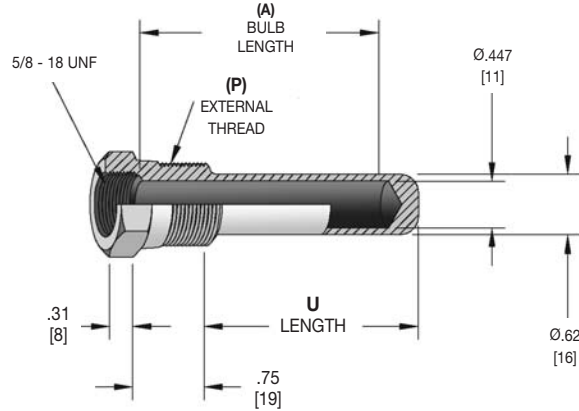

### Lengths

(A) Bulb Length	Standard		with Lagging Extension	
	U Length	(T)	(T)	U Length
2"	2.13 [54]	—	—	—
4"	3.88 [99]	2.00 [51]	2.13 [54]	
6"	5.75 [146]	2.00 [51]	3.88 [99]	
8"	7.75 [197]	2.00 [51]	5.75 [146]	
12"	11.75 [299]	3.00 [76]	7.50 [191]	
18"	17.75 [451]	3.00 [76]	15.75 [400]	
24"	23.75 [603]	3.00 [76]	21.75 [552]	

### Pressure Rating (psi) per ASME Boiler Code, Section VIII, Part UG28

Material	Operating Temperature			
	70°F	200°F	400°F	600°F
Brass	1200	1000	200	—
Carbon Steel	1600	1470	1430	1275
304 Stainless Steel	2100	1940	1600	1340
316 Stainless Steel	2100	2000	1900	1770

### with Lagging Extension

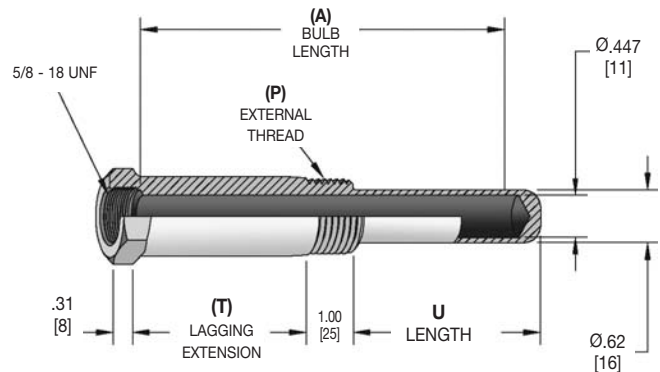

Alternative materials and accessories are also available. Please consult the Options and Accessories Section for details.

Selection of the proper thermowell is the sole responsibility of the user. Temperature and pressure limitations must be considered. Improper application may cause failure of the thermowell, resulting in possible personal injury or property damage.

### HOW TO ORDER

Sample Order Number: **7-3 G 2**

Thermowell Style	(P) External Thread	(A) Bulb Length**	(T) Lagging Extension	Material	
7- Dial	3 1/2 NPT	D 2" Bulb	C 2" Extension (4" and longer Bulb only)	2 Brass 3 Steel 5 304SS 6 316SS	
		G 4" Bulb			
	4 3/4 NPT	J 6" Bulb	E 3" Extension (12" and longer Bulb only)		
		L 8" Bulb			
			R 12" Bulb*		Omit if None
			Wa 18" Bulb*		
			Wk 24" Bulb*		

\*Not available with 1/2 NPT external thread.

\*\*Dial Thermowells with Bulb Lengths over 6" are typically for use with Adjustable Union or Bendable Extension Connections.