

Bottom Connect

BIMETAL THERMOMETERS



B85404 shown

- ▶ 3", 5" Dial Size
- ▶ ± 1.0% Full Scale Accuracy
- ▶ Stainless Steel Case & Steel
- ▶ External Reset

The Trerice **Bottom Connection Bimetal Thermometer** has been designed to meet the needs of standard industrial applications and installations. This instrument features a stainless steel, hermetically sealed case, providing weather tight protection.

- Optional features available: Please consult the Options & Accessories Section for details.

Thermowell

- For corrosive or pressure applications, use of a thermowell is recommended to prevent damage to the thermometer and facilitate its removal from the process (refer to pages 155-161). For correct use and application of all Bimetallic thermometers, please refer to the Bimetallic Actuated Thermometer Standard ASME B40.3.

Specifications

Models	Dial Sizes
B834	3"
B854	5"
Case	300 stainless steel, hermetically sealed
Stem	300 stainless steel, 1/4" diameter
Coil	Bimetallic, silicone dampened on ranges to 300°F (148°C), above 300°F not dampened
Connection	Bottom, 1/2 NPT
Window	Double strength glass
Pointer	Balanced, black finished
Dial Face	Aluminum, white background with black and blue graduations and markings
External Reset	Yes
Accuracy	±1.0 % Full Scale ASME B40.3 Grade A

Approximate Shipping Weight

B834: 0.8 lbs [0.36 kg]
B854: 1.6 lbs [0.72 kg]

HOW TO ORDER

Sample Order Number: **B834 04 04**

Model	Stem Length	Range Code
B834	02 2 1/2" Stem	See Standard Ranges
B854	04 4" Stem	
	06 6" Stem	
	09 9" Stem	
	12 12" Stem	
	15 15" Stem	
	18 18" Stem	
	24 24" Stem	

Other lengths available: Specify in inches (72" maximum)

Bottom Connect

All dimensions are nominal. Dimensions in [] are in millimeters.

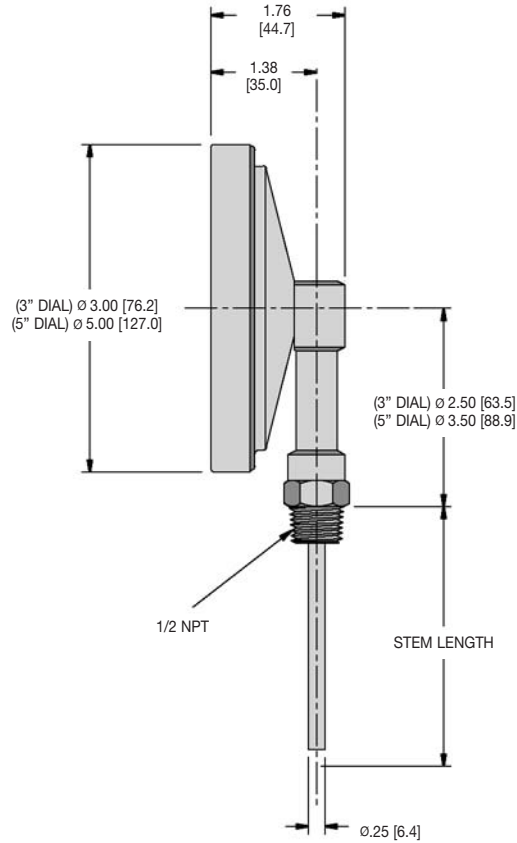

BIMETAL THERMOMETERS

Standard Ranges

Dual Scale (Fahrenheit & Celsius Range)		Fahrenheit only Range		Celsius only Range		Fahrenheit		Celsius	
Range Code	Range	Range Code	Range	Range Code	Range	Figure Intervals	Minor Divisions	Figure Intervals	Minor Divisions
01*†	-100° to 100°F & -75° to 40°C	01F*†	-100° to 100°F	01C*†	-75° to 40°C	20°	2°	10°	1°
02	-40° to 160°F & -40° to 70°C	02F	-40° to 160°F	02C	-40° to 70°C	20°	2°	10°	1°
03*†	25° to 125°F & -5° to 50°C	03F*†	25° to 125°F	03C*†	-5° to 50°C	10°	1°	5°	1/2°
04	0° to 200°F & -20° to 95°C	04F	0° to 200°F	04C	-20° to 95°C	20°	2°	10°	1°
05	20° to 240°F & -10° to 115°C	05F	20° to 240°F	05C	-10° to 115°C	20°	2°	10°	1°
27	0° to 250°F & -20° to 120°C	27F	0° to 250°F	27C	-20° to 120°C	50°	2°	20°	2°
06	50° to 300°F & 10° to 150°C	06F	50° to 300°F	06C	10° to 150°C	50°	2°	20°	2°
07	50° to 400°F & 10° to 200°C	07F	50° to 400°F	07C	10° to 200°C	50°	5°	50°	2°
08	50° to 500°F & 10° to 260°C	08F	50° to 500°F	08C	10° to 260°C	50°	5°	50°	2°
09*	150° to 750°F & 50° to 400°C	09F*	150° to 750°F	09C*	50° to 400°C	100°	10°	50°	5°
10*	200° to 1000°F & 100° to 550°C	10F*	200° to 1000°F	10C*	100° to 550°C	100°	10°	100°	5°

* Minimum stem length for these ranges is 4".

† Minimum insertion length for these ranges is 3".