

760B

Low Pressure Gauge • Black Finished Steel Case

SPECIALTY GAUGES



760B shown

- ▶ 2 1/2", 4" Dial Sizes
- ▶ ±1.6% Accuracy
- ▶ Drawn Steel Case

The Trerice **760B** Low Pressure Gauge is designed to accurately measure extreme low pressure conditions. This pressure gauge employs a diaphragm capsule sensing element to measure the low pressure. Case material is drawn steel with brass wetted parts.

- Optional features and case style variations available: Please consult the Options & Accessories Section for details.
- For correct use and application of all pressure gauges, please refer to: Pressure Gauge Standard ASME B40.100.

Specifications

Model

760B

Dial Sizes 2 1/2", 4"

Wetted Parts

316L stainless steel diaphragm capsule, brass socket

Movement Brass

Connection 2 1/2" Dial Size: Lower male or center back male, 1/4 NPT
4" Dial Size: Lower male or center back male, 1/4 or 1/2 NPT

Case Drawn steel, black finished, stem-mounted flangeless

Window Polycarbonate, snap-in

Pointer Plain, black finished

Dial Face Aluminum, white background with black graduations and markings

Accuracy ±1.6% Full Scale

Maximum Temperature
140°F (65°C)

Approximate Shipping Weight

2 1/2" Dial Size:
0.3 lbs [0.14 kg]

4" Dial Size:
0.89 lbs [0.36 kg]

HOW TO ORDER

Sample Order Number: **760B 25 02 L T 660**

Model	Dial Size	Connection Size	Connection Location	Units of Measure	Range Code
760B	25 2 1/2" 40 4"	02 1/4 NPT 04 1/2 NPT*	L Lower B Back	T Pressure W Vacuum	See Standard Ranges

* 1/2 NPT connection size available only with 4" dial size.

760B

All dimensions are nominal. Dimensions in [] are in millimeters.

Low Pressure Gauge • Black Finished Steel Case

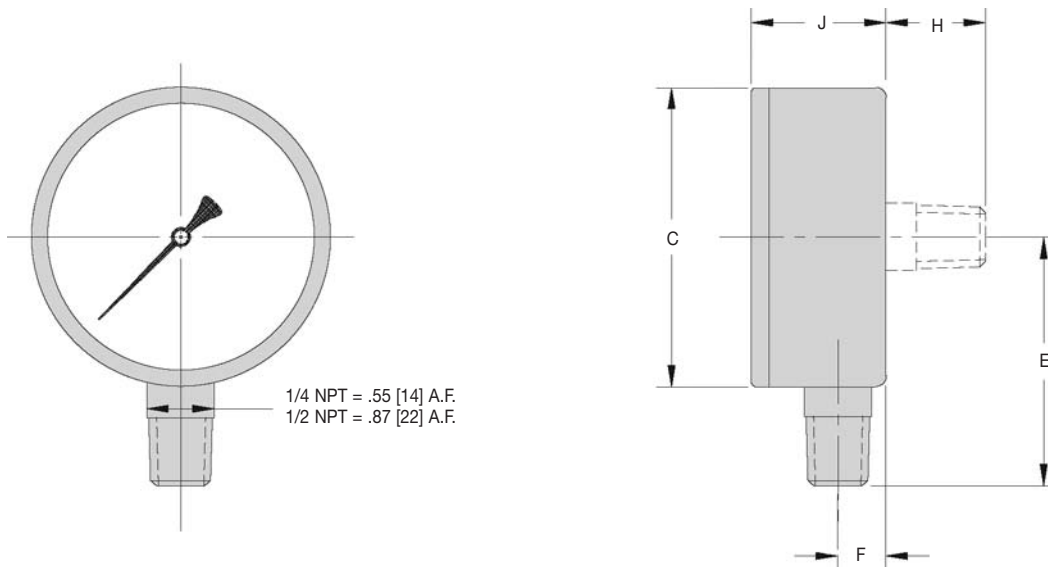

Dial Size	C	E	F	H	J
2 1/2"	2.44 [62]	2.20 [56]	0.37 [9.5]	0.98 [25]	1.34 [34]
4"	3.90 [99]	3.23 [82]	0.61 [16]	0.98 [25]	1.22 [44]
4" (1/2 NPT)	3.90 [99]	3.43 [87]	0.61 [16]	1.38 [35]	1.22 [44]

Standard Ranges

Pressure (T)			
Range Code	Specific Range	Figure Intervals	Minor Divisions
645	0/10 in. H ₂ O	1	0.1
650	0/15 in. H ₂ O	5	0.2
660	0/30 in. H ₂ O	5	0.5
670	0/60 in. H ₂ O	10	1
680	0/100 in. H ₂ O	10	1
690	0/160 in. H ₂ O	20	2
700	0/200 in. H ₂ O	20	2
720	0/300 in. H ₂ O	50	5
652	0/10 oz./in. ²	1	0.1
655	0/15 oz./in. ²	5	0.2
662	0/20 oz./in. ² & 0/34 in. H ₂ O	5	1
667	0/30 oz./in. ²	5	0.5
680	0/60 oz./in. ²	10	1
695	0/100 oz./in. ²	10	1
715	0/160 oz./in. ²	20	2
750	0/250 oz./in. ²	50	5
675	0/3 psi	0.5	0.05
685	0/5 psi	1	0.1
715	0/10 psi	1	0.1

Standard Ranges

Vacuum (W)			
Range Code	Specific Range	Figure Intervals	Minor Divisions
580	15/0 in. H ₂ O	5	0.2
600	30/0 in. H ₂ O	5	0.5
610	60/0 in. H ₂ O	10	1
620	100/0 in. H ₂ O	10	1
635	200/0 in. H ₂ O	20	2
595	15/0 oz./in. ²	5	0.2
605	30/0 oz./in. ²	5	0.5
620	60/0 oz./in. ²	10	1
633	100/0 oz./in. ²	10	1

SPECIALTY GAUGES