

# 940E Series Electric Motor Control Valve

CONTROL VALVES



940E shown

- ▶ Fail Open or Closed
- ▶ Cast Aluminum or Iron Linkages
- ▶ 1/2" – 8" Valve Sizes

The Trerice **940E Series** Control Valve uses an AC power supply to stroke the valve via an actuator drive, electric motor, and valve linkage unit. The actuator drive causes the motor to drive the valve stem up or down in relation to an input signal (factory set at 4-20 mA, field switchable to 0-10 VDC) from a controller. Electric motors are available to accept a power supply of 24 or 120 VAC and can be specified for failure in an open, closed, or last position upon loss of power. Linkages are available in two sizes (30 and 52), the larger of which uses leverage to provide increased shut-off capabilities on smaller valves and is required for use on larger sized valves.

For optimal performance, the service conditions (medium, flow, temperature, inlet and outlet pressures) of the application must be considered when selecting a valve. Please refer to the Valve Selection Section of this catalog. Consult the Valve Selection tables for the capabilities of a particular valve/actuator assembly. A positioner may be required to maximize the shut-off capability of the valve. Improper application may cause failure of the valve, resulting in possible personal injury or property damage.

## Specifications

**Model**  
940E

**Linkages**  
30, 52

**Motor Case**  
Aluminum

**Yoke**  
Linkage 30: Aluminum  
Linkage 52: Cast-iron

**Power Supply**  
24 VAC, 60 Hz, 2.5 A or  
120 VAC, 60 Hz, 0.5 A

**Input Signal**  
4-20 mA or  
0-10 VDC

**Fail Position**  
Stem-Out (open),  
Stem-In (closed), or Last Position

**No-Load Timing**  
Fail Stem-In or Stem-Out: 90 seconds  
Fail Last Position: 120 seconds

**Protection**  
NEMA 1 (indoor only)

**Maximum Temperature**  
Ambient: 130°F (54°C)  
Process Flow: 400°F (204°C)

**Humidity**  
Maximum: 95% RH

**Approximate Shipping Weight**  
**Actuator:**  
Linkage 30: 15 lbs [6.8 kg]  
Linkage 52: 30 lbs [13 kg]

**Valve Body:**  
see Valve Selection tables

Sample Order Number: **940E-30-J36-27**

## HOW TO ORDER

Model	Linkage Size	Valve Body Number	Power Supply	Fail Position
940E	30	Refer to pages 252-260	1 120 VAC, 60 Hz, 0.5 A	6 Stem-Out (open)
	52		2 24 VAC, 60 Hz, 2.5 A	7 Stem-In (closed)
				8 Last Position

1. **Determine** the valve size, style and material required by the application.
2. **Consult** the Valve Selection table to determine the required Valve Body.
3. **Refer** to the maximum close-off pressure columns to determine the Linkage Size needed to provide the close-off pressure required by your application.
4. **Specify** the Model and Linkage Size.
5. **Specify** the Valve Body Number.
6. **Specify** the Power Supply and Fail Position codes.

# 940E Series

## Electric Motor Control Valve

All dimensions are nominal. Dimensions in [ ] are in millimeters.

CONTROL VALVES

### Linkage Size 30

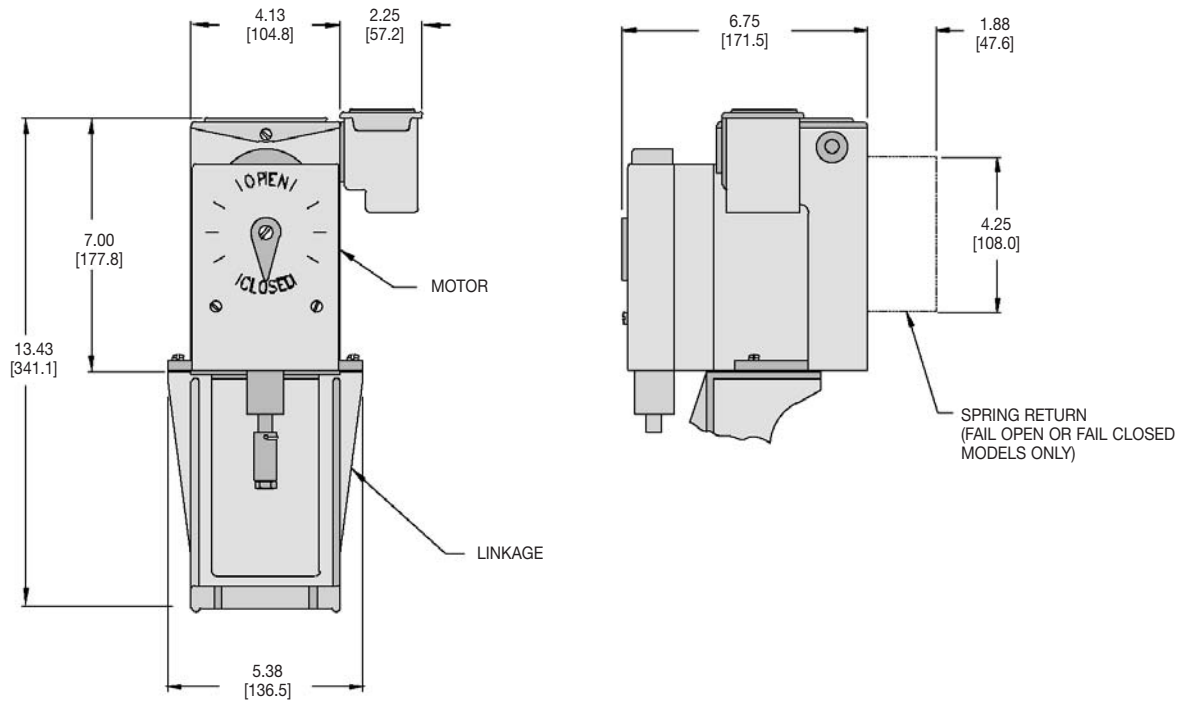

### Linkage Size 52

