

BRONZE

All dimensions are nominal. Dimensions in [] are in millimeters

Valve Body Selection (for 910TB Control Valve)

Single or Double Seat • 1/2" – 2"

CONTROL VALVES

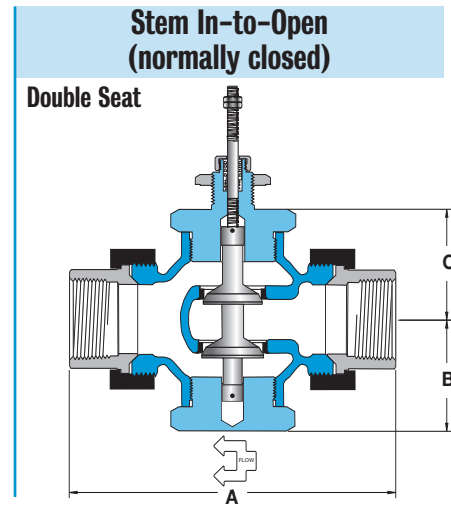
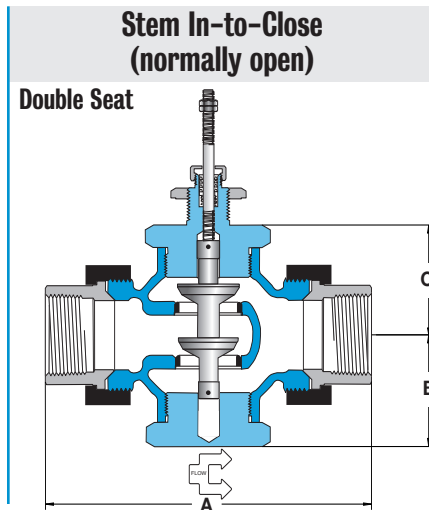
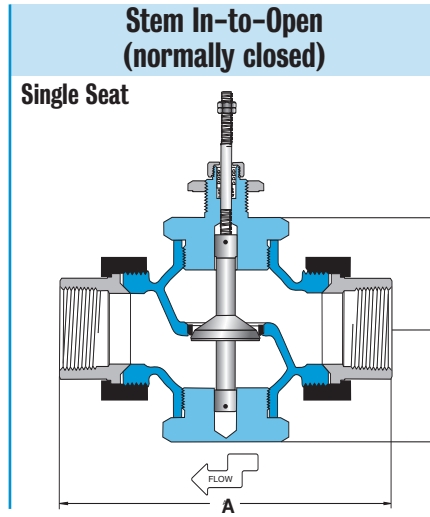
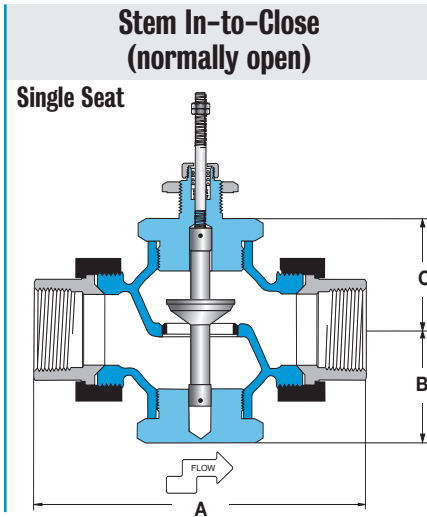

Specifications

Body Material	Trim Material	Trim Style	Connection	Pressure & Temperature Rating
Bronze	Stainless steel	Modified linear	Threaded, malleable iron union ends	250 PSI @ 410°F (210°C)

Valve Body Selection

Valve Body Number		Size		Number of Seats	C _v	Maximum Close-Off Pressure (psid)	Actuator 910TB	Dimensions			Approximate Shipping Wt.
ITC Normally Open	ITO Normally Closed	Connection (NPT)	Nominal Port					A	B	C	
A02	A03	1/2	1/8"	1	0.17	250	4.8 [122]	1.8 [46]	1.8 [46]	3.0 lbs [1.35 kg]	
A05	A06	1/2	3/16"	1	0.35	250	4.8 [122]	1.8 [46]	1.8 [46]	3.0 lbs [1.35 kg]	
A08	A09	1/2	1/4"	1	0.7	250	4.8 [122]	1.8 [46]	1.8 [46]	3.0 lbs [1.35 kg]	
A11	A12	1/2	3/8"	1	1.4	250	4.8 [122]	1.8 [46]	1.8 [46]	3.0 lbs [1.35 kg]	
A14	A15	1/2	1/2"	1	2.8	250	4.8 [122]	1.8 [46]	1.8 [46]	3.0 lbs [1.35 kg]	
A21	A24	3/4	3/4"	2	8	250	5.6 [142]	2.3 [58]	2.3 [58]	5.0 lbs [2.25 kg]	
A29	A33	1	1"	2	12	250	6.0 [152]	2.3 [58]	2.3 [58]	6.1 lbs [2.75 kg]	
A39	A44	1 1/4	1 1/4"	2	21	250	7.2 [183]	2.6 [66]	2.6 [66]	10.1 lbs [4.55 kg]	
A50	A55	1 1/2	1 1/2"	2	30	250	7.7 [196]	2.6 [66]	2.6 [66]	11.1 lbs [5.00 kg]	
A61	A66	2	2"	2	47	250	8.6 [218]	3.1 [79]	3.1 [79]	17.0 lbs [7.65 kg]	