

# STEAM TRAPPING PRIMER

Steam Trapping Primer – **NICHOLSON** has been known throughout the 20th Century as a pioneer and engineering leader in the Steam Trapping industry. Our line of Steam Traps includes the four major types: Mechanical, Thermodynamic, Thermostatic and Drain Orifice.

**NICHOLSON** Steam Traps are available for use at temperatures to 800° F, and pressures from vacuum to 3000 PSIG.

# BASICS OF STEAM TRAPS

## WHY DO WE NEED STEAM TRAPS?

In order to operate economically and efficiently, all steam systems must be protected against 3 factors:

- \* CONDENSATE
- \* AIR
- \* NON-CONDENSIBLES

**Condensate** is formed in a system whenever steam gives up its useable heat. And, since condensate interferes with the efficiency of the operation of a steam system, it must be removed.

**Air**, one of nature's finest insulators, when mixed with steam, will lower its temperature and hinder the overall effectiveness of an entire system. For example: A film of air 1/1000th of an inch thick offers as much resistance to heat transfer as 13" of copper or 3" of steel. For that reason, air **MUST** be continuously bled from a system by steam traps to have it operate efficiently and to conserve energy.

**Non-condensibles**, such as carbon dioxide promote corrosion and other deterioration of equipment and inhibit their function.

## WHAT IS A STEAM TRAP?

A steam trap is basically an automatic valve which discharges condensate, undesirable air and non-condensibles from a system while trapping, or holding in, steam. They fall into 4 major categories; **Thermostatic, Mechanical, Thermodynamic** and **Drain Orifice**. Each type will be discussed in detail in this section.

In every steam system, there are four phases of operation in which traps play a vital role:

- 1) **Start-up** – During "start-up", when the system is initially activated, air and non-condensibles must be discharged.
- 2) **Heat-up** – During "heat-up", as the system works to achieve the desired temperature and pressure, condensate is discharged.
- 3) **At Temperature** – "At temperature", when the desired levels are reached, the valve must close to retain the steam.
- 4) **Using Heat** – At the "using heat" level, the valve's job is to stay closed unless and until condensate occurs; then the valve must open, discharge the condensate and close

quickly and positively, without allowing valuable steam to escape.

## WHAT ARE THE QUALITIES OF A GOOD STEAM TRAP?

*A good steam trap should:*

- Discharge condensate, air and non-condensibles.
- Be equal to the load over a wide range of pressures and temperatures.
- Be freeze-proof where necessary.
- Be simple and rugged.
- Have few moving parts.
- Require low maintenance and spare parts inventory.
- Have a long life.

*A good steam trap should not:*

- Discharge live steam.
- Fail or malfunction if pressure changes.
- Respond slowly or hesitantly.
- Open too often, too briefly or for too long.
- Require constant adjustment or frequent repair.
- Require a wide variety of models, spare parts or orifice sizes for different pressures.

# THERMOSTATIC STEAM TRAPS

Thermostatic steam traps, as their name implies, operate in direct response to the temperature within the trap. There are two primary types: *BELLOWS* and *BIMETALLIC*.

## BELLOWS TRAPS

Of all actuating devices, the bellows trap most nearly approaches ideal operation and efficiency and is most economical. It is positive in both directions, is fast acting and does not require adjustment. Bellows traps employ only one moving part - a liquid filled metal bellows - which responds quickly and precisely to the presence or absence of steam.

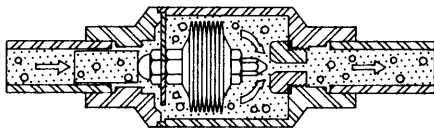

FIGURE 13

During startup and warmup, a vacuum in the bellows keeps it retracted, with the valve lifted well clear of the seat permitting air and non-condensibles to be freely discharged (Figure 13).

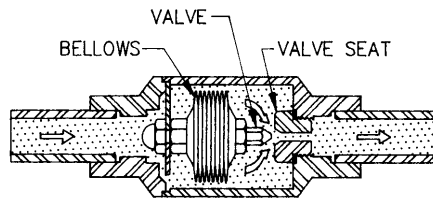
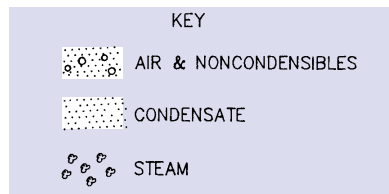

FIGURE 14

Next, condensate is discharged (Figure 14). Then heat from arriving steam will cause the liquid in the bellows to vaporize and close the valve (Figure 15).

At temperature, the valve will remain closed indefinitely opening only when condensate, air or other non-condensibles cause it to retract and open.

When live steam re-enters the trap housing, the bellows extends immediately, trapping the steam (Figure 15).

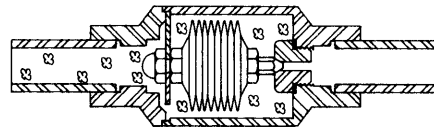

FIGURE 15

The bellows, unlike a disc trap, is a temperature sensitive rather than a time cycle device. There is no way that air can be mistaken for steam and cause binding, since bellows react to temperature only. And unlike bucket traps, bellows traps do not require a variety of sizes for valves and seats for various pressures.

## BIMETALLIC TRAPS

Bimetallic traps work like the differential metal strip in a thermostat, using the unequal expansion of two different metals to produce movement which opens and closes a valve.

Figure 16: When the cooler condensate contacts the bimetallic discs, the discs relax. Inlet pressure forces the valve away from its seat and permits flow.

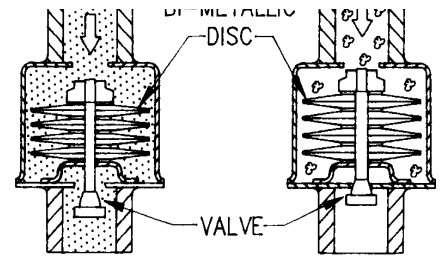

FIGURE 16

FIGURE 17

Figure 17: When steam enters the trap and heats the bimetallic discs, the discs expand forcing the valve against its seat preventing flow.

Bimetallic traps are simple and positive in both directions. However, they have a built-in delay factor which makes them inherently sluggish. Moreover; they do not maintain their original settings because the elements tend to take a permanent set after use, which requires repeated adjustment to maintain efficiency.

# MECHANICAL STEAM TRAPS

There are two basic types of mechanical steam traps:

- 1) FLOAT & THERMOSTATIC
- 2) INVERTED BUCKET

Inverted bucket traps, as their name suggests, operate like an upside down bucket in water.

Figure 1: During startup, the trap is filled with water, with the bucket (A) at

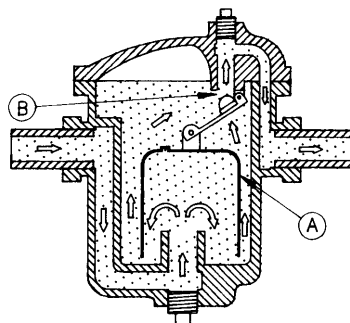
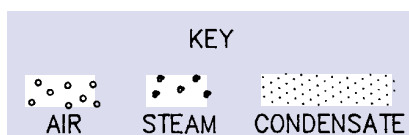

FIGURE 1

the bottom and the valve (B) fully open to allow condensate to flow out freely.

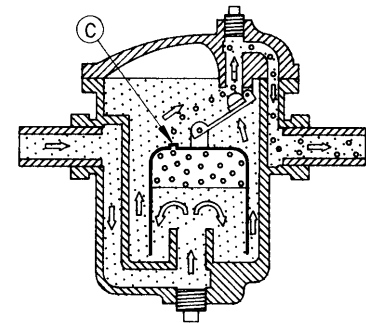
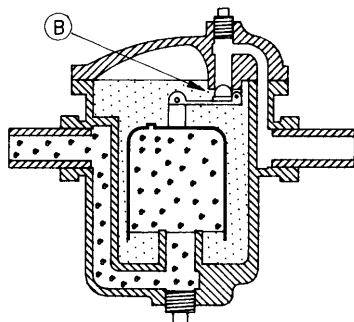

FIGURE 2

Figure 2: Air trapped in the bucket escapes through a vent hole (C). On

# MECHANICAL STEAM TRAPS CONT'D.

some buckets, an additional vent hole is controlled by a bimetallic strip which is kept closed by the steam. Therefore, the vent only operates during startup. This limits bucket trap air handling capacity.



**FIGURE 3**

**Figure 3:** At temperature, steam enters under the bucket and causes it to float up and close the valve (B). During heat use, any condensate entering the line is forced up into the bucket. The bucket loses buoyancy and drops down, reopening the valve and discharging the condensate. (see Figure 1)

Bucket traps are rugged and reliable, however, air building up in the bucket can bind them closed causing condensate to back up in the line. Also, they can waste steam if they lose their prime

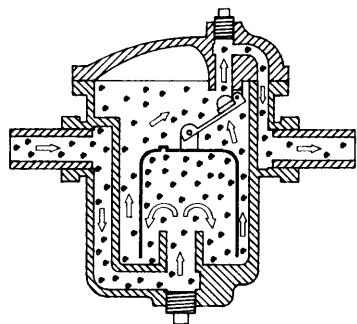
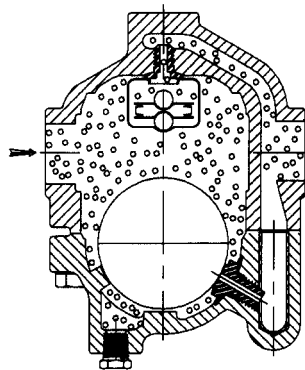

**FIGURE 4**

(see Figure 4). Bucket traps require priming water in the trap which makes them vulnerable to freeze up unless expensive insulation is added.

Because bucket traps rely on a fixed force, the weight of the bucket, discharge orifices must be sized by pressure. For example, a trap sized to operate at 50 PSIG will not open at 150 PSIG.

Float traps are manufactured in a variety of sizes, shapes and configurations. The most commonly used (for steam service) is the float and thermostatic, or F & T. F & T traps combine the excellent air venting capabilities of a thermostatic trap with the liquid level controlling capabilities of a float trap.



**FIGURE 5**

**Figure 5:** During startup, before condensate reaches the trap, the thermostatic element is fully open to discharge air. The float rests on the lower seat.

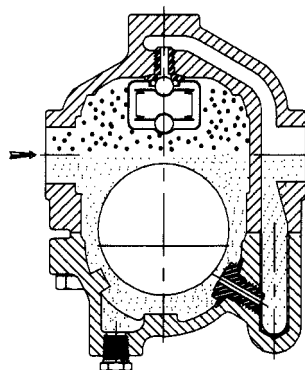

**FIGURE 6**

**Figure 6:** As hot condensate and steam reach the trap, the thermostatic element expands, closing the air vent. Condensate lifts the float, allowing condensate to flow out of the trap.

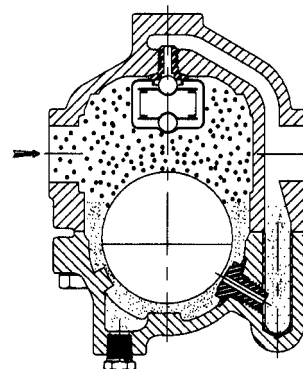

**FIGURE 7\***

**Figure 7:** As the condensating rate decreases, the float lowers, reducing flow through the trap. The buoyancy of the float will maintain a liquid level seal above the lower seat ring, preventing the escape of steam. As with inverted bucket traps, float and thermostatic traps rely on a fixed force (the buoyancy of the float). Discharge orifices must be sized by differential pressure. Placing a low pressure float and thermostatic trap in high pressure service will result in the trap locking up. A contrasting characteristic of both the float and thermostatic and inverted bucket is the discharge cycle. A float & thermostatic trap tends to continuously discharge condensate while the inverted bucket trap discharges condensate in cycles.

\*NFT Free Float Steam Trap shown

# THERMODYNAMIC STEAM TRAPS

Essentially, a thermodynamic steam trap is a time cycle device which responds to imbalances of pressure applied to a valving device, usually a disc.

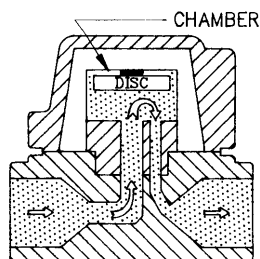

FIGURE 9

**Figure 9:** Pressure caused by air and condensate lifts the disc permitting flow through the trap.

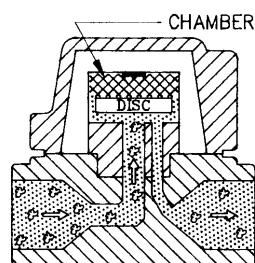

FIGURE 10

**Figure 10:** When steam arrives at the inlet port, blowby at a high velocity creates low pressure under the disc. Some of the flashing condensate is

blown past the disc into the upper chamber, forcing the disc downward.

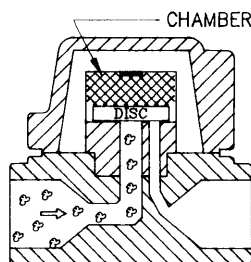

FIGURE 11

**Figure 11:** Further flow is stopped when sufficient pressure is trapped in the chamber above the disc. During operation, a decrease in chamber pressure permits inlet pressure to lift the disc and open the trap (**Figure 9**).

The decrease in the chamber pressure should only be caused by the presence of cooler condensate. Due to the design of most thermodynamic traps, especially in cold or wet conditions, the chamber may be prematurely cooled causing improper or frequent cycling as well as steam loss and increased wear. Advanced TD designs have a steam jacket which surrounds the chamber and prevents ambient conditions affecting the operation of the disc.

This type of trap is also subject to water binding. If water pressure is trapped above disc, trap will fail closed.

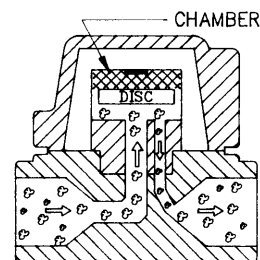
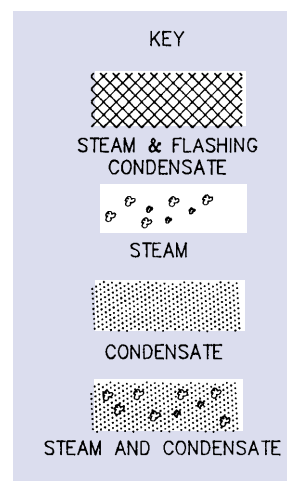

FIGURE 12

**Figure 12:** Trap is easily affected by dirt and/or other foreign matter which will cause trap to fail open.



## ORIFICE STEAM TRAPS

Orifice type traps are engineered continuous flow devices. Orifice traps discharge air, condensate and all other non-condensable gases with minimal live steam loss.

The fixed orifice size is calculated, for a given application, to discharge the condensate load at maximum thermal efficiency. Approximately 10 to 25 percent of discharging hot condensate flashes to steam at the downstream side of the orifice, at a constant pressure drop. This flashing effect further restricts the flow of saturated steam. In actual conditions, a minimum percentage of steam, by weight, is discharged with condensate, since the specific

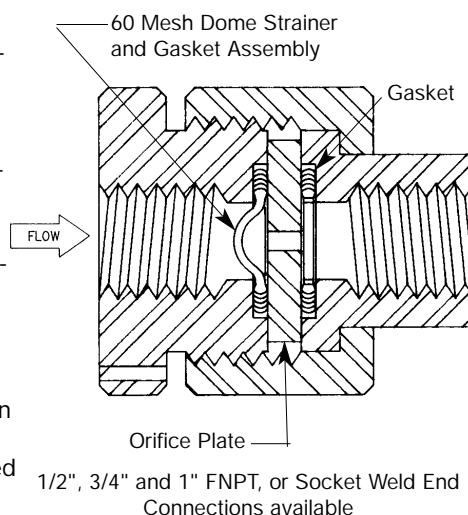

volume of steam is relatively large compared to that of the condensate.

The velocity through the orifice is highly turbulent. The initial calculated steam loss can be expected to remain relatively constant over the expected trap life of 10 plus years.

The major factor for energy efficient performance is based on initial orifice sizing for the application. Properly sized, thermal efficiencies of 98 percent plus can be attained.

While Orifice Traps can be applied at all pressures, they are ideally suited for use on saturated or superheated steam 250 PSIG or greater.

# SIZING STEAM TRAPS

## HOW TO DETERMINE THE PROPER SIZE TRAP

Capacity tables that follow show maximum discharge rates in pounds per hour. To select the correct size trap from these tables, the normal condensing rate should be converted to a "pounds per hour" basis and multiplied by a safety factor.

### REASON FOR SAFETY FACTORS

For steam applications, the condensation rate varies with:

- (1) The starting or warming-up condition.
- (2) The normal operating condition.
- (3) Any abnormal operating condition.

Of these, the condensing rate for the normal condition is occasionally known, or it can be estimated with sufficient accuracy for trap selection; the loads imposed by warm-up and abnormal conditions are seldom known and practically impossible to predict.

During warm-up the trap load is heavy, since air as well as large quantities of condensate must be discharged. Condensate forms at a rapid rate as the cold equipment and connecting piping are brought up to temperature. This usually results in pressure drop at the trap inlet, thereby reducing its capacity during the period when the load is maximum.

Safety factors are therefore necessary, to compensate for start-up conditions, variation of steam pressure and product initial temperature, the process cycle speed required, and discrepancies between assumed and actual conditions which determine the normal condensing rate.

The selection of a safety factor depends on the type of trap and the operating conditions. If the known or calculated normal condensing rate is multiplied by the recommended factor from the pages which follow, efficient trapping will be assured.

## EFFECT OF BACK PRESSURE ON TRAP CAPACITY

Most trap installations include piping the outlet into a common return system or to an available disposal location. In either case a constant static back pressure may exist, against which the trap must discharge. This back pressure may be unintentional or deliberately produced.

Unintentional back pressure in condensate return piping is caused by lifting the condensate to a higher level, piping which is too small for the volume of liquid conveyed, piping with insufficient or no pitch in the direction of flow, pipe and fittings clogged with rust, pipe scale or other debris, leaking steam traps, etc. In steam service an intentional back pressure is instigated by means of a pressure regulating or spring-loaded valve in the discharge system, when a supply of flash steam at a pressure less than the trap pressure is needed.

If very hot condensate is discharged to a pressure less than that existing in the trap body, some of it will flash into steam, with a tremendous increase in volume and consequent choking and build-up of pressure in the trap's discharge orifice and the passages and piping adjacent thereto. For condensate at or close to steam temperature, this flash pressure is quite high, usually considerably higher than any static back pressure existing in the trap outlet piping.

For this reason, capacity tables for thermostatic and thermodynamic traps are based on gage pressure at the trap inlet, instead of on the difference between trap inlet and discharge pressures. Experiments have shown that, for the

temperatures applying to these tables, unless the static back pressure in the return piping exceeds 25% of the trap inlet pressure, no reduction of the trap capacity results. For back pressures greater than 25% of the trap inlet pressure there is a progressive decrease of trap capacity.

Thus, if the return piping static pressure is less than 25% of the trap inlet pressure, the capacities shown in these tables should be utilized for trap selection. If the return piping pressure is greater than 25% of the trap inlet pressure, reduce the table capacities by the percentage indicated in second line of Table A on the following pages.

Above data does not apply to mechanical traps, capacities are based on differential pressure, obtained by subtracting any static back pressure from trap inlet pressure.

### WHEN THE NORMAL CONDENSING RATE IS KNOWN

Normal condensing rate means the pounds of steam condensed per hour by the average conditions which prevail when the equipment drained is at operating temperature.

If this amount is known, simply multiply by the safety factor recommended for the service and conditions, obtained from the pages which follow, and determine size directly from the capacity tables for the type of trap selected.

### WHEN THE NORMAL CONDENSING RATE IS UNKNOWN

Determine by utilizing proper formula for the service and equipment to be trapped. Multiply the result by safety factor recommended for the operating conditions. See examples on the following pages.

# SIZING STEAM TRAPS CONT'D.

## EXPLANATION OF SYMBOLS USED IN NORMAL CONDENSING RATE FORMULAS

- A** = Heating surface area, square feet (see Table B)
- B** = Heat output of coil or heater, BTU per hour
- C** = Condensate generated by submerged heating surfaces, lbs/hr/sq ft (Table F)
- D** = Weight of material processed per hour after drying, pounds
- F** = Steam flow, lbs/hr
- G** = Gallons of liquid heated per unit time
- H** = Heat loss from bare iron or steel heating surface, BTU/sq ft/°F/hr
- L** = Latent heat of steam at pressure utilized, BTU/lb (see Table C or obtain from Steam Table)
- M** = Metal weight of autoclave, retort or other pressure vessel, pounds
- Qh** = Condensate generated, lbs/hr
- Qu** = Condensate generated, lbs/unit time (Always convert to lbs/hr before applying safety factor. See Examples using formulas 7 and 10 on next page).
- S** = Specific heat of material processed, BTU/lb/°F
- Ta** = Ambient air temperature, °F
- Tf** = Final temperature of material processed, °F
- Ti** = Initial temperature of material processed, °F
- Ts** = Temperature of steam at pressure utilized, °F (see Table C or obtain from Steam Table)
- U** = Overall coefficient of heat transfer, BTU/sq ft/°F/hr (see Table E)
- V** = Volume of air heated, cubic feet/minute
- Wg** = Liquid weight, lbs/gallon
- Wh** = Weight of material processed per hour, lbs
- Wu** = Weight of material processed per unit time, lbs
- X** = Factor for  $\frac{T_f - T_i}{L}$  (obtain from Table B)
- Y** = Factor for  $\frac{H(T_s - T_a)}{L}$ , lbs/hr/sq ft (obtain from Table C)

## AIR HEATING

**Steam Mains; Pipe Coil Radiation; Convectors; Radiators; etc.** (Natural Air Circulation)

$$(1) Q_h = A Y$$

*Recommended Safety Factors*

### For Steam Mains

#### Ambient Air Above Freezing:

|                            |   |
|----------------------------|---|
| 1st Trap After Boiler..... | 3 |
| At End of Main .....       | 3 |
| Other Traps .....          | 2 |

#### Ambient Air Below Freezing:

|                      |   |
|----------------------|---|
| At End of Main ..... | 4 |
| Other Traps .....    | 3 |

Steam mains should be trapped at all points where condensate can collect, such as at loops, risers, separators, end of mains, ahead of valves, where mains reduce to smaller diameters, etc., regardless of the condensate load. Installation of traps at these locations usually provides ample capacity.

### For Pipe Coil Radiation, Convectors and Radiators

|                              |   |
|------------------------------|---|
| Single Continuous Coil ..... | 2 |
| Multiple Coil .....          | 4 |

**Damp Space Pipe Coil Radiation; Dry Kilns; Greenhouses; Drying Rooms; etc.** (Natural Air Circulation)

$$(2) Q_h = 2.5 A Y$$

*Recommended Safety Factors*

|                              |   |
|------------------------------|---|
| Single Continuous Coil ..... | 2 |
| Multiple Coil .....          | 4 |

**Steam Line Separators; Line Purifiers**

$$(3) Q_h = .10 F$$

*Recommended Safety Factors*

|  |        |
|--|--------|
| Indoor Pipe Line .....   | 2      |
| Outdoor Pipe Line .....  | 3      |
| If Boiler Carry-Over Anticipated... (Depending on probable severity of conditions) | 4 to 6 |

**Unit Heaters; Blast Coils** (Forced Air Circulation)

(4) When BTU Output is Known:

$$Q_h = \frac{B}{L}$$

(5) When BTU Output is Unknown, Heat Transfer Area is Known:

$$Q_h = 5 A Y$$

(6) When Volume of Air Heated is Known:

$$Q_h = 1.09 V X$$

*Recommended Safety Factors*

|   |   |
|---|---|
| Intake Air Above Freezing - Constant Steam Pressure ..... | 3 |
| Intake Air Above Freezing - Variable Steam Pressure ..... | 4 |
| Intake Air Below Freezing - Constant Steam Pressure ..... | 4 |
| Intake Air Below Freezing - Variable Steam Pressure ..... | 5 |

**Example:** 11,500 cubic feet of air per minute heated by blast coil from 50°F to 170°F with 50 PSIG constant steam pressure.

**Solution:** By formula (6),  $Q_h = 1.09 \times 11,500 \times .132 = 1655$  lbs/hr. Recommended safety factor, 3 for intake air above freezing and constant steam pressure.  $3 \times 1655 = 4965$  lbs/hr trap capacity required.

# SIZING STEAM TRAPS CONT'D.

## LIQUID HEATING

**Submerged Coils; Heat Exchangers; Evaporators; Stills; Vats; Tanks; Jacketed Kettles; Cooking Pans; etc.**

(7) When Quantity of Liquid to be Heated in a Given Time is Known:

$$Q_u = G W_g S X$$

(8) When Quantity of Liquid to be Heated is Unknown:

$$Q_h = A U X$$

(9) When Heating Surface Area is Larger than Required to Heat Known Quantity of Liquid in a Given Time:

$$Q_h = A C$$

When maximum heat transfer efficiency is desired, or when in doubt, use formula (9) in preference to formulas (7) and (8).

### Recommended Safety Factors

**For Submerged Coil Equipment; Heat Exchangers; Evaporators; etc.**

#### Constant Steam Pressure:

- Single Coil, Gravity Drainage ..... 2
- Single Coil, Siphon Drainage ..... 3
- Multiple Coil, Gravity Drainage .... 4

#### Variable Steam Pressure:

- Single Coil, Gravity Drainage ..... 3
- Single Coil, Siphon Drainage ..... 4
- Multiple Coil, Gravity Drainage .... 5

For Siphon Drained Equipment, specify traps with "Steam Lock Release Valve".

**For Jacketed Equipment; Cooling Kettles; Pans; etc.**

#### Slow Cooking:

- Gravity Drainage ..... 3
- Siphon Drainage ..... 4

#### Moderately Fast Cooking:

- Gravity Drainage ..... 4
- Siphon Drainage ..... 5

#### Very Fast Cooking:

- Gravity Drainage ..... 5
- Siphon Drainage ..... 6

For Siphon Drained Equipment, specify traps with "Steam Lock Release Valve".

**Example:** Heat exchanger with single submerged coil, gravity drained, heating 1250 gallons of petroleum oil

of 0.51 specific heat, weighing 7.3 lbs/gal, from 50°F to 190°F in 15 minutes, using steam at 100 PSIG.

**Solution:** By formula (7),  $Q_u = 1250 \times 7.3 \times .51 \times .159 = 740$  pounds of condensate in 15 minutes, or  $4 \times 740 = 2960$  lbs/hr. Recommended safety factor is 2 for single coil, gravity drained.  $2 \times 2960 = 5920$  lbs/hr trap capacity required.

## DIRECT STEAM CONTACT HEATING

**Autoclaves; Retorts; Sterilizers; Reaction Chambers; etc.**

$$(10) Q_u = W_u S X + .12 M X$$

### Recommended Safety Factors

- Slow Warm-up Permissible ..... 3
- Fast Warm-up Desired ..... 5

**Example:** An autoclave which weighs 400 pounds before loading is charged with 270 pounds of material having a specific heat of .57 and an initial temperature of 70°F. Utilizing steam at 50 PSIG, it is desired to bring the temperature up 250°F in the shortest possible time.

**Solution:** By formula (10),  $Q_u = (270 \times .57 \times .198) + .12(400 \times .198) = 40$  pounds of condensate. Using safety factor of 5 recommended for fast warm-up and assuming 5 minutes as the time required to complete the reaction, a trap capacity of  $40 \times 12 \times 5 = 2400$  lbs/hr is required.

## INDIRECT STEAM CONTACT HEATING

**Cylinder Dryers, Drum Dryers, Rotary Steam Tube Dryers, Calenders; etc.**

$$(11) Q_h = \frac{970 (W - D)}{L} + W_h X$$

### Recommended Safety Factors

**For Siphon or Bucket Drained Rotating Cylinder, Drum and Steam Tube Dryers; Cylinder Ironers; etc.**

- Small or medium Size, Slow Rotation .....4

- Small or Medium Size, Fast Rotation .....6
- Large Size, Slow Rotation ..... 6
- Large Size, Fast Rotation ..... 8

For Siphon or Bucket Drained Equipment, specify traps with "Steam Lock Release Valve". Each cylinder should be individually trapped.

### For Gravity Drained Chest Type Dryers and Ironers

- Each Chest Individually Trapped... 2
- Entire Machine Drained By Single Trap ..... 4 to 6
- Depending on number of Chests

### For Platen Presses

- Each Platen Individually Trapped ... 2
- \*Entire Press Drained by Single Trap, Platens Piped in Series .....3
- \*Entire Press Drained by Single Trap, Platens Piped in Parallel ..... 4 to 6
- Depending on number of Platens

**Example:** A medium size rotary steam tube dryer with condensate lifted to a discharge passage in the trunion, dries 4000 lbs/hr of granular material to 3300 pounds, with 15 PSIG steam, initial temperature of material 70°F, final temperature 250°F.

**Solution:** By formula (11)  $Q_h = \frac{970 (4000 - 3300)}{945} + (4000 \times .191)$

= 1483 lbs/hr. Using safety factor of 4 recommended for medium size, slow rotation:  $4 \times 1483 = 5932$  lbs/hr trap capacity required.

*\*A separate trap for each heating surface (coil, chest, platen, etc.) is recommended for maximum heating efficiency. Sluggish removal of condensate and air is certain when more than one unit is drained by a single trap, resulting in reduced temperatures, slow heating and possible water-hammer damage.*

**TABLE A — EFFECT OF BACK PRESSURE ON STEAM TRAP CAPACITY**

|  |    |    |    |    |    |    |    |    |    |    |
|--|----|----|----|----|----|----|----|----|----|----|
| Back Pressure as Percent of Inlet Pressure | 10 | 20 | 25 | 30 | 40 | 50 | 60 | 70 | 80 | 90 |
| Percent Reduction of Trap Capacity         | 0  | 0  | 0  | 2  | 5  | 12 | 20 | 30 | 40 | 55 |

**TABLE B – SQUARE FEET OF SURFACE PER LINEAL FOOT OF PIPE**

|                              |     |     |     |     |     |     |     |     |      |      |      |      |      |      |      |      |      |      |      |
|------------------------------|-----|-----|-----|-----|-----|-----|-----|-----|------|------|------|------|------|------|------|------|------|------|------|
| Nominal Pipe Size (In.)      | 1/2 | 3/4 | 1   | 1¼  | 1½  | 2   | 2½  | 3   | 4    | 5    | 6    | 8    | 10   | 12   | 14   | 16   | 18   | 20   | 24   |
| Area, Sq. Ft. per Lineal Ft. | .22 | .28 | .35 | .44 | .50 | .63 | .76 | .92 | 1.18 | 1.46 | 1.74 | 2.26 | 2.81 | 3.34 | 3.67 | 4.19 | 4.71 | 5.24 | 6.28 |

**TABLE C - FACTOR Y - H(Ts-Ta)/L - APPROXIMATE CONDENSING RATE FOR BARE IRON AND STEEL PIPE\***

|                               |      |      |      |      |      |      |      |      |      |      |      |      |      |      |      |      |      |      |      |
|-------------------------------|------|------|------|------|------|------|------|------|------|------|------|------|------|------|------|------|------|------|------|
| Steam Pressure - PSIG         | 1    | 2    | 5    | 10   | 15   | 20   | 25   | 50   | 75   | 100  | 150  | 200  | 250  | 300  | 350  | 400  | 450  | 500  | 600  |
| Steam Temperature - °F        | 215  | 219  | 227  | 239  | 250  | 259  | 267  | 298  | 320  | 338  | 366  | 388  | 406  | 422  | 436  | 448  | 460  | 470  | 489  |
| Latent Heat - BTU/lb          | 968  | 966  | 961  | 952  | 945  | 939  | 934  | 911  | 895  | 879  | 856  | 839  | 820  | 804  | 790  | 776  | 764  | 751  | 728  |
| Factor Y Cond - lbs/hr/sq.ft. | 0.45 | 0.46 | 0.49 | 0.53 | 0.56 | 0.59 | 0.71 | 0.84 | 1.02 | 1.10 | 1.34 | 1.47 | 1.58 | 1.80 | 1.91 | 2.00 | 2.35 | 2.46 | 2.65 |

\*Based on still air at 60F, recommended safety factors compensate for air at other temperatures. Used for steam trap selection only.

**TABLE D — FACTOR X = (Tf-Ti)/L**

| Tf-Ti<br>°F | STEAM PRESSURE - PSIG |      |      |      |      |      |      |      |      |      |      |      |      |      |      |      |      |      |      |  |
|-------------|-----------------------|------|------|------|------|------|------|------|------|------|------|------|------|------|------|------|------|------|------|--|
|             | 1                     | 2    | 5    | 10   | 15   | 20   | 25   | 50   | 75   | 100  | 150  | 200  | 250  | 300  | 350  | 400  | 450  | 500  | 600  |  |
| 40          | .041                  | .041 | .042 | .042 | .042 | .043 | .043 | .044 | .045 | .045 | .047 | .048 | .049 | .050 | .051 | .052 | .052 | .053 | .055 |  |
| 60          | .062                  | .062 | .062 | .063 | .064 | .064 | .064 | .066 | .067 | .068 | .070 | .072 | .073 | .075 | .076 | .077 | .079 | .080 | .082 |  |
| 80          | .083                  | .083 | .083 | .084 | .085 | .085 | .086 | .087 | .089 | .091 | .093 | .096 | .098 | .100 | .101 | .103 | .105 | .106 | .110 |  |
| 100         | .103                  | .103 | .104 | .105 | .106 | .106 | .107 | .110 | .112 | .114 | .117 | .120 | .122 | .124 | .127 | .129 | .131 | .133 | .137 |  |
| 120         | .124                  | .124 | .125 | .126 | .127 | .128 | .129 | .132 | .134 | .136 | .140 | .144 | .146 | .149 | .152 | .155 | .157 | .160 | .165 |  |
| 140         | .145                  | .145 | .146 | .147 | .148 | .149 | .150 | .154 | .156 | .159 | .163 | .167 | .171 | .174 | .177 | .180 | .183 | .186 | .192 |  |
| 160         | .165                  | .166 | .167 | .168 | .169 | .170 | .172 | .176 | .179 | .182 | .187 | .191 | .195 | .199 | .203 | .206 | .210 | .213 | .220 |  |
| 180         |                       |      | .187 | .189 | .191 | .192 | .193 | .198 | .201 | .204 | .210 | .215 | .220 | .224 | .228 | .232 | .236 | .240 | .248 |  |
| 200         |                       |      |      | .211 | .212 | .213 | .214 | .219 | .224 | .227 | .234 | .239 | .244 | .249 | .253 | .258 | .262 | .266 | .275 |  |
| 220         |                       |      |      |      | .235 | .236 | .242 | .246 | .250 | .257 | .262 | .268 | .274 | .279 | .283 | .288 | .293 | .303 |      |  |
| 240         |                       |      |      |      |      |      | .263 | .268 | .273 | .280 | .286 | .292 | .299 | .304 | .309 | .314 | .319 | .330 |      |  |
| 260         |                       |      |      |      |      |      |      | .290 | .296 | .304 | .310 | .317 | .324 | .329 | .335 | .340 | .346 | .357 |      |  |
| 280         |                       |      |      |      |      |      |      | .313 | .319 | .327 | .334 | .342 | .349 | .354 | .361 | .367 | .373 | .385 |      |  |
| 300         |                       |      |      |      |      |      |      |      |      | .350 | .358 | .366 | .373 | .380 | .387 | .393 | .400 | .412 |      |  |

**TABLE E — FACTOR U, HEAT TRANSFER COEFFICIENTS  
BTU/HR/SQ FT/°F TEMP. DIFFERENTIAL**

| TYPE OF HEAT EXCHANGER              | AVERAGE DESIGN VALUES |                    |
|-------------------------------------|-----------------------|--------------------|
|                                     | NATURAL CIRCULATION   | FORCED CIRCULATION |
| STEAM TO WATER                      | 125                   | 300                |
| STEAM TO OIL                        | 20                    | 45                 |
| STEAM TO MILK                       | 125                   | 300                |
| STEAM TO PARAFFIN WAX               | 25                    | 80                 |
| STEAM TO SUGAR & MOLASSES SOLUTIONS | 75                    | 150                |

Coefficients shown are suggested average design values. Higher or lower figures will be realized for many conditions. Use for steam trap selection only.

**TABLE F — FACTOR C, APPROXIMATE CONDENSING RATE FOR SUBMERGED SURFACES,  
LBS/HR/SQ FT**

| HEATING SURFACE | DIFFERENCE BETWEEN STEAM TEMPERATURE AND MEAN WATER TEMPERATURE* |    |    |     |     |     |     |     |     |     |     |     |
|-----------------|--|----|----|-----|-----|-----|-----|-----|-----|-----|-----|-----|
|                 | 25   | 50 | 75 | 100 | 125 | 150 | 175 | 200 | 225 | 250 | 275 | 300 |
| IRON OR STEEL   | 1.6  | 5  | 10 | 17  | 25  | 34  | 45  | 57  | 70  | 84  | 99  | 114 |
| BRASS           | 2.6  | 8  | 16 | 27  | 40  | 54  | 72  | 91  | 112 | 134 | 158 | 182 |
| COPPER          | 3.2  | 10 | 20 | 34  | 50  | 68  | 90  | 114 | 140 | 168 | 198 | 228 |

\* Mean water temperature is 1/2 the sum of inlet temperature plus outlet temperature. Table based on heating surfaces submerged in water with natural circulation. Safety factor of 50% has been included to allow for moderate scaling. If surface will remain bright, multiply above figures by 2. Use for steam trap selection only.

# SIZING STEAM LINES

## SIMPLE SIZING CRITERIA

Proper detailed design of a steam system should be done using detailed calculations for frictional losses in steam piping. The following examples and rules are meant to provide simple guidelines to see if steam pipe sizes are possibly undersized. They do not imply any design liability by Nicholson. Undersizing of steam lines can lead to reduced pressure to process equipment and impaired performance of valves, heat exchangers and steam traps. Steam line sizing along with condensate return line sizing should always be checked when a system is not performing up to expectations.

**EXAMPLE:** The system shown in Figure 3.1 will be used as our example. The Supply "S" at the right is 120 psig steam which is branching off to steam users A, B, C, D & E. The equipment usage is indicated in lbs/hr. The segments of piping will be addressed going backwards from the furthest end user A. The steam flow going through the pipe segment from the intersection X to equipment A is 1000 lb/hr (the usage of A). **A simple rule of thumb** for smaller steam piping (6" and below) is to keep steam velocities below 10,000 feet/minute (165 feet/second) for **short lengths of pipe only**.

The length of the steam line between X and A is 1000 feet, so the simple rule of thumb can not be applied here because the pressure drop will be too high. The pressure drop should be kept to a minimum, or supply pressure to the equipment will droop.

**SOLUTION BY CHART:** The chart is a graphic solution to help select pipe sizes. The pressure values used for this chart are in psia (absolute). For values given in gage pressure (psig), you must add 15 psi (14.7 psi actual). The example we will use is for saturated steam flow, but this chart does have corrections for superheat. There will be an overall system pressure drop, so that the pressure is assumed to be 5 to 10 psig below the supply pressure of 120 psig (135 psia). Enter the chart at the

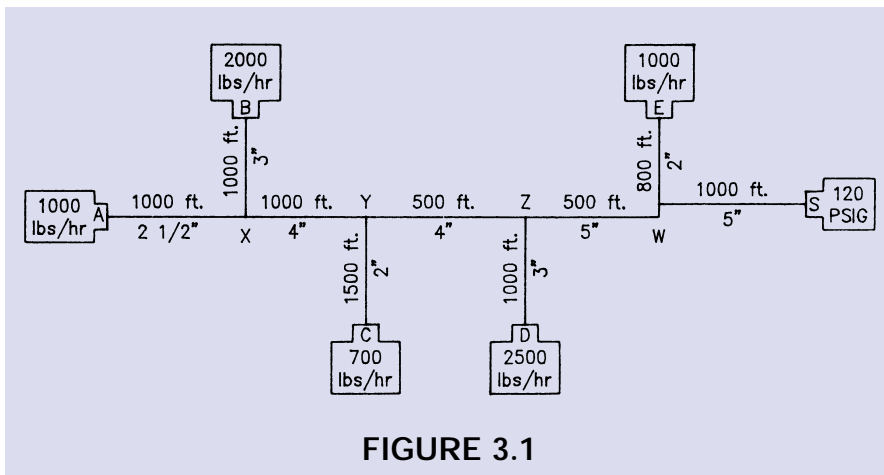

FIGURE 3.1

top at a point representing 130 psia and proceed vertically downward. Enter the chart at the right at the value of the steam flow in Lb/minute (1000 lb/hr = 16.7 lb/min) and move horizontally across until the horizontal line intersects the vertical line. You will proceed along the diagonal, downward and to the right, parallel with the other diagonal lines.

This chart can be used two ways: either to determine the pressure drop of an existing pipe or to determine the correct pipe size for a specific pressure drop.

**TO SIZE LINES:** On the bottom of the chart is a pressure drop per 100 feet of pipe, select a value of 0.25 psi per 100 feet. This indicates 2.5 psi as the total loss for 1000 feet. Enter the chart at the bottom at .25 and move upward until you intersect the diagonal line. Proceed from the intersection horizontally left until you reach the actual pipe inside diameter to determine the pipe size. In this example, the pipe size for section X to A should be 2 1/2" pipe.

**TO FIGURE PRESSURE DROP:** Enter the chart on the left side at your pipe size and proceed horizontally until you intersect with the diagonal line. Proceed vertically downward to determine the pressure drop per 100 feet of pipe.

The next section of pipe to determine would be X to B. This would have the same pressure, but the intersection of

the vertical line would be at the horizontal steam flow of 33 lb/min (2000 lb/hr) for user B. The choice of pipe sizes can be argued, a 4" will yield 0.1 psi/100 feet pressure drop (1.0 psi per 1000 feet), but the more economical solution of a 3" pipe yields a 0.4psi/100 feet pressure drop. **Note:** when selecting the smaller more economical pipe size, there is less room for expansion and pressure drops will increase should additional process capacity arise.

For common sections of header such as Y to X, the steam flow for both steam users A and B must be combined. The vertical line will now intersect with the horizontal steam flow line coming across at 50 lb/min (3000 lb/hr). Using a 4" line will bring the pressure drop to a value of 0.22 psi/100 feet, or 2.2 psi for the 1000 foot section.

Remember that pressure drop figures from the bottom of the chart are per 100 feet, so segments such as Y to C have a larger total pressure drop because the distance is longer. Similarly, the total pressure drop from Z to Y is less because the distance is only 500 feet. The values for steam flow continue to be additive for each steam user: Z to Y is 3700 lb/hr (61.7 lb/min), W to Z is 6200 lb/hr (103.3 lb/min) and S to W is 7200 lb/hr (120 lb/min). Pipe sizes in Figure 3.1 are given for your reference and provide the user with reasonable pressure drops in the steam lines.

# SIZING STEAM LINES CONT'D.

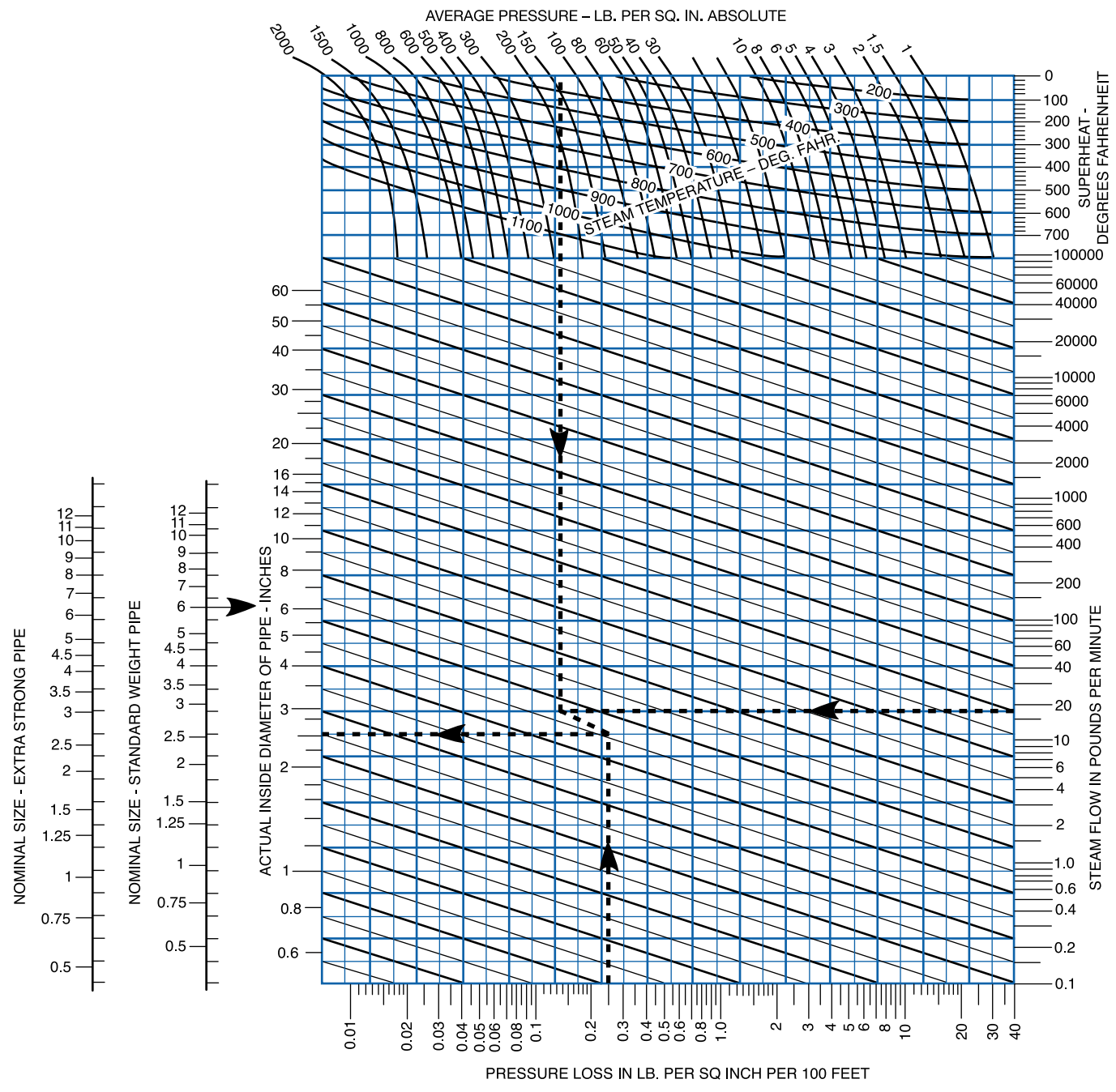

# SIZING CONDENSATE RETURN LINES

## SIZING CONDENSATE RETURN LINES

When condensate passes through a steam trap orifice, it drops from the upstream pressure in the heat exchanger to the downstream pressure in the condensate return line. The energy in the upstream condensate is greater than the energy in the downstream condensate. As the condensate passes through the steam trap, the additional energy from the upstream condensate forms a percentage of flash steam that changes based upon the upstream

and downstream pressures (this percentage can be seen in Table 5 in the Condensate Commander section).

When sizing condensate return lines after the steam trap, it is important to take into account the amount of flash steam created when hot, saturated condensate undergoes a pressure drop. The flash steam has very large volume and can cause very high velocities if the return line is not sized properly. These high velocities can create high backpressure in the return line that often

leads to poor steam trap performance.

We will size the condensate return line based upon flash steam velocities. The percentage of flash steam versus condensate (water) is usually on the order of 20 to 1, so the effect of the water in the system sizing is usually small. Choosing a velocity of flash steam is often subjective and different manufacturers will suggest different values. The nomograph below sizes return lines based upon 50 feet/second.

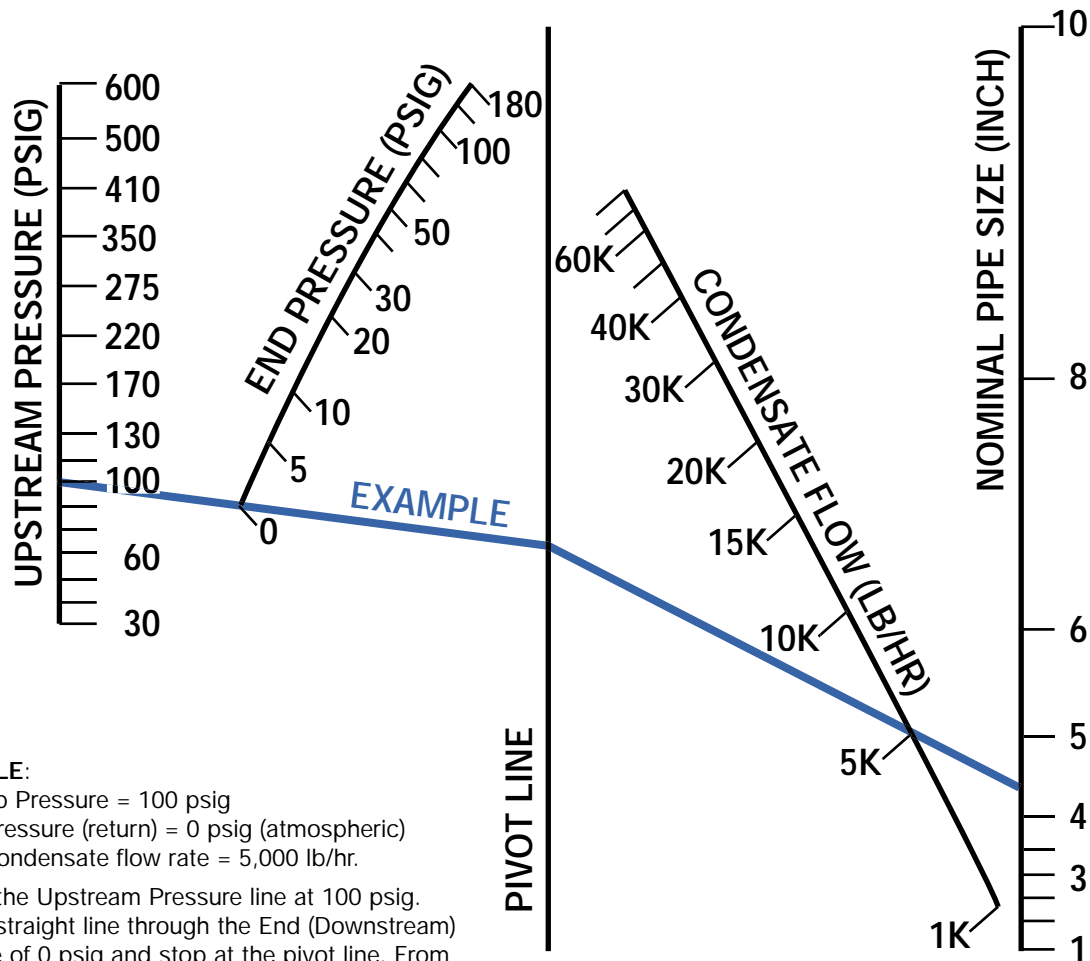

### EXAMPLE:

Inlet Trap Pressure = 100 psig  
 Outlet Pressure (return) = 0 psig (atmospheric)  
 Actual condensate flow rate = 5,000 lb/hr.

Start at the Upstream Pressure line at 100 psig. Make a straight line through the End (Downstream) Pressure of 0 psig and stop at the pivot line. From that point, make a straight line through the Condensate Flow Rate of 5,000 and stop at the Nominal Pipe size line. It intersects slightly higher than 4". You may select the 4" line size without concern for undersizing the line because a low velocity of 50 ft/sec was used.

Note: If design requirements dictate using a velocity other than the 50 ft/sec value in the Nomograph, a ratio can be made of the pipe size because the velocity is proportional to the Pipe Diameter

squared. For example, if you require a Pipe Diameter for 80 ft/sec, use the following equation:

$$\text{Nomograph Diameter} \times \sqrt{\frac{50 \text{ FT/SEC}}{\text{New Velocity (FT/SEC)}}}$$

Example: The Nomograph Diameter determined in the previous example is 4.2". Using the above formula, the Pipe Diameter for 80 ft/sec is 3.3".

# STEAM TRACING DESIGN GUIDELINES

## V.1.1 INTRODUCTION

Steam tracing is one of many ways to preheat, add heat and prevent heat loss from piping systems and their components. Some other ways are:

- ☛ Jacketed piping
- ☛ Hot water and oil tracing
- ☛ Dowtherm tracing

Jacketed piping systems are used primarily to maintain a constant high temperature. Due to its high cost of construction, jacketed systems are seldom used except where temperature control is critical. Hot water and oil must be pumped at a high velocity to maintain a desired temperature, and must have a separate return header as does Dowtherm. Hot water, oil or dowtherm are also an additional system which add to the cost of a plant.

Steam tracing is most often selected because:

- ☛ There is generally available a surplus of low and/or medium pressure steam.
- ☛ Steam has a high latent heat and heat-transfer-coefficient.
- ☛ Steam condenses at a constant temperature.
- ☛ Steam flows to end-point without the aid of pumps (when designed correctly).
- ☛ A small amount of return piping is needed due to existing condensate headers.

## V.1.2 USES

### *Freeze Protection (winterizing)*

- ☛ Adding sufficient heat to above-grade piping systems and equipment which are exposed to ambient temperatures below the freezing point of their media prevents freezing.

### *Maintaining A Desired Temperature*

- ☛ The viscosity of some liquids becomes higher as their temperatures become lower causing more difficult and costly pumping and leading to down-time for cleaning.
- ☛ Condensation may occur in some gases if the ambient temperature falls below the dewpoint which is harmful and expensive in such systems as:
  - Natural Gas where control valves freeze up and burners malfunction.
  - Compressor Suction Lines where compressors can be damaged.

## V.1.3 MATERIAL

Steam tracing material is normally as follows:

- Use the material specified for steam piping from the steam header (through the distribution manifold, if applicable) to and including the tracer block valve.
- Use 1/4" through 7/8" O.D. copper or stainless steel tubing (depending on the design conditions) from the block valve to the steam trap. Though sizes may vary with different applications, 3/8" and 1/2" O.D. are the most often used. Tube fittings and adapters are normally flareless compression type or 37 degree flared type.
- Use the material specified for condensate piping from the steam trap (through the collection manifold, if applicable) to the condensate header or end-point (drain or grade).

## V.1.4 DESIGN GUIDELINES

1. Steam piping should be run within 12" of the line or equipment being traced to minimize exposed tubing.
2. Spiral tracing should be limited to vertical piping using multiple tracers on horizontal lines which require more heat.

3. Tracers should be designed so that the flow is always down. **Avoid pockets!** Where vertical flow is unavoidable, steam pressure should be a minimum of 25 PSIG for every 10' of rise.
4. Tracers should be a maximum of 100' long and continuous from the supply to the collection manifold or endpoint. For lines over 100' long, provide another tracer and overlap the two 3 inches to avoid cold spots.
5. Tracers should have no branch tees except as indicated in *Section V.3*.
6. Provide each tracer with a separate strainer and steam trap.
7. Manifolds can be horizontal or vertical depending upon the design conditions.
8. Tracers should be attached to the pipe at 8" to 10" maximum intervals with stainless steel wire. Wire tension should be sufficient to hold the tracer secure and flush against the pipe.
9. Some piping materials, such as lined pipe, might require spacer blocks to avoid "hot spots".
10. Tracer loops with unions are necessary:
  - ☛ when joining tubing lengths.
  - ☛ at all break flanges and unions.
  - ☛ at all flanged valves.
11. Tracer discharge lines should be as short as possible since long discharge lines can freeze even with a fully functioning steam trap.

# CLEAN STEAM DESIGN GUIDELINES

Clean Steam is a general term used to describe a range of steam pureness. It may be generated by such methods as:

- Filtration of plant steam typically requiring the removal of particles larger than 5 microns
- An independent steam generator. E.g. Stainless steel reboiler fed with distilled water.
- One stage of a multi-effect still within the overall water purification system.

Uses for Clean Steam vary by industry, however typical applications include:

- In-line sterilization of storage tanks and equipment
- Powering sterilizers and autoclaves
- Cleaning and sterilizing process piping systems without disassembling the piping system - commonly known as CIP (Clean in Place)
- Pasteurization utilizing Ultra High Temperature Processing (UHT)

The highest quality clean steam however, is typically used by the Pharmaceutical and Biotechnical industries. This steam, occasionally referred to as "Pure Steam", is most often supplied by an independent steam generator utilizing Water for Injection (WFI) as feed water. WFI is typically produced by a Reverse

Osmosis (RO) generator and then distilled thus removing any traces of organics, bacteria, and pyrogens. Pure steam is required for the sterilization of cell culture processing equipment such as incubators where contaminants could adversely affect cell growth. Other uses include pharmaceutical manufacture and direct steam injection pasteurization where contaminants could collect in products intended for human consumption.

Clean steam produced from high purity make up water is highly corrosive due to the minimal ion content. High purity water, pure steam and the resultant condensate will aggressively attempt to absorb or leach ions from their environment to achieve a more natural balance. Additionally, chemicals used to passivate steam and condensate in conventional systems are generally prohibited from clean steam system as such chemicals could contaminate or alter sensitive end products. Should corrosion begin, the oxidation byproducts may travel through the steam system catalyzing corrosion throughout in a process known as 'rouging'.

To combat the corrosive nature of clean steam, design practices require piping, fittings and valving to be comprised of corrosion resistant materials. Current industry accepted

materials include 304L, 316 and 316L stainless steel and higher alloys such as Inconel. While these materials have proven themselves in practice, it should be noted that there are currently no U.S. governmental standards specifying materials for clean steam service. Regulatory agencies concern themselves with the purity and quality of the product, leaving the design standards entirely up to the manufacturer.

In addition to the use of corrosion resistant materials in sanitary systems, features designed to inhibit bacterial growth are often required. Piping, valves and fittings should be free draining and maintain industry standard surface finishes. Free draining valves and fittings are designed not to retain or 'Puddle' condensate when installed correctly. After shut down of the steam system, any puddled condensate could potentially promote bacterial growth. Inadequate surface finishes reduce the effectiveness of system sterilization techniques, increasing the possibility of bacterial contamination. Industry standard surface finishes are measured in micro inches, the lower the number the smoother, and are expressed as an arithmetic average (Ra). Typical industry specified surface finishes range from 32 to 10  $\mu$  in. Ra.

## PIPING & TRAPPING DESIGN GUIDELINES

1. Extra care should be taken for expansion stresses due to the higher coefficient of expansion for stainless steel.
2. Branch connections are to be made from the top of headers with the block valve as close as possible to the header.
3. The recommended types of branch connections are tees and reducing tees.
4. Steam lines should slope down to traps (recommended 1% min.).
5. A dirt leg with trap station is recommended at every change of elevation (no undrainable pockets).
6. Extra care should be taken in pipe supports to eliminate sagging.
7. Instruments in general should be kept to a minimum. However, where required, it is recommended that:
  - A) All are installed in tees.
  - B) Pressure gauges be installed with diaphragm seals.
  - C) Flow meters be installed in the vertical flow-up position to eliminate pockets
  - D) Pressure reducing stations be kept to a minimum.
8. Traps should be installed in the vertical flow-down position to eliminate pockets.
9. Trap block valves should be located as close as possible to the user.
10. Condensate lines should be sloped (recommended 1% min.) to the end point. Note that contaminated condensate should always be piped to a process sewer. Uncontaminated condensate (from drip legs) may be recovered, if cost effective, and used elsewhere in the plant (not as Clean Steam make-up).
11. Condensate terminal points should contain an air break (2" or 2 pipe diameters, whichever is greater) between the end of the pipe and the drain, floor or grade.
12. Test connections for traps are recommended-trap efficiency is essential for Clean Steam.

# SIZING ELIMINATOR STEAM SEPARATORS

## SIZING FOR STEAM APPLICATIONS

Using your system pressure and capacity, select a size from the Pressure Drop Tables below that will yield a pressure drop in **boldface** type. This will provide the most efficient separation with velocities between 30 and 100 ft/s for sizes up to 2½" and between 30 and 90 ft/s for sizes 3" and above.

## EXAMPLE

For a system under 400 PSIG with a capacity of 500#/hr, a 1/2" or 3/4" separator is recommended.

- A 1/2" separator will provide a 1.86 PSIG pressure drop.
- A 3/4" separator will provide a 0.59 PSIG pressure drop.

## ELIMINATOR PRESSURE DROP TABLES – STEAM

### 1/2 INCH ELIMINATOR

| #/HR | PRESSURE (PSIG) |             |             |             |             |             |             |             |             |
|------|-----------------|-------------|-------------|-------------|-------------|-------------|-------------|-------------|-------------|
|      | 25              | 50          | 75          | 100         | 200         | 300         | 400         | 500         | 600         |
| 100  | 0.71            | <b>0.45</b> | <b>0.33</b> | <b>0.26</b> | <b>0.15</b> | 0.1         | 0.07        | 0.06        | 0.05        |
| 200  | 2.83            | 1.8         | 1.32        | 1.05        | <b>0.62</b> | <b>0.39</b> | 0.3         | 0.24        | 0.2         |
| 300  | 6.37            | 4.04        | 2.97        | 2.36        | <b>1.39</b> | <b>0.88</b> | <b>0.67</b> | <b>0.54</b> | 0.46        |
| 400  | 11.33           | 7.18        | 5.28        | 4.19        | 2.47        | <b>1.56</b> | <b>1.19</b> | <b>0.96</b> | <b>0.81</b> |
| 500  | 17.7            | 11.22       | 8.26        | 6.55        | 3.86        | <b>2.44</b> | <b>1.86</b> | <b>1.5</b>  | <b>1.27</b> |
| 600  | 25.49           | 16.16       | 11.89       | 9.43        | 5.55        | 3.52        | <b>2.69</b> | <b>2.16</b> | <b>1.82</b> |

### 1 INCH ELIMINATOR

| #/HR | PRESSURE (PSIG) |             |             |             |             |             |             |             |             |
|------|-----------------|-------------|-------------|-------------|-------------|-------------|-------------|-------------|-------------|
|      | 25              | 50          | 75          | 100         | 200         | 300         | 400         | 500         | 600         |
| 300  | 0.76            | <b>0.48</b> | <b>0.35</b> | <b>0.28</b> | <b>0.17</b> | 0.1         | 0.08        | 0.06        | 0.05        |
| 500  | 2.11            | 1.34        | 0.98        | <b>0.78</b> | <b>0.46</b> | <b>0.29</b> | 0.22        | 0.18        | 0.15        |
| 700  | 4.13            | 2.62        | 1.93        | 1.53        | <b>0.9</b>  | <b>0.57</b> | <b>0.44</b> | 0.35        | 0.3         |
| 900  | 6.83            | 4.33        | 3.19        | 2.53        | <b>1.49</b> | <b>0.94</b> | <b>0.72</b> | <b>0.58</b> | <b>0.49</b> |
| 1100 | 10.21           | 6.47        | 4.76        | 3.78        | 2.22        | <b>1.41</b> | <b>1.08</b> | <b>0.87</b> | <b>0.73</b> |
| 1300 | 14.26           | 9.04        | 6.65        | 5.27        | 3.11        | <b>1.97</b> | <b>1.5</b>  | <b>1.21</b> | <b>1.02</b> |
| 1500 | 18.98           | 12.03       | 8.85        | 7.02        | 4.14        | 2.62        | <b>2</b>    | <b>1.61</b> | <b>1.36</b> |

### 1-1/2 INCH ELIMINATOR

| #/HR | PRESSURE (PSIG) |             |             |             |             |             |             |             |             |
|------|-----------------|-------------|-------------|-------------|-------------|-------------|-------------|-------------|-------------|
|      | 25              | 50          | 75          | 100         | 200         | 300         | 400         | 500         | 600         |
| 400  | <b>0.24</b>     | <b>0.15</b> | <b>0.11</b> | <b>0.09</b> | 0.05        | 0.03        | 0.03        | 0.02        | 0.02        |
| 500  | 0.37            | <b>0.24</b> | <b>0.17</b> | <b>0.14</b> | 0.08        | 0.05        | 0.04        | 0.03        | 0.03        |
| 1000 | 1.49            | 0.95        | <b>0.7</b>  | <b>0.55</b> | <b>0.33</b> | 0.21        | 0.16        | 0.13        | 0.11        |
| 2000 | 5.98            | 3.79        | 2.79        | 2.21        | <b>1.3</b>  | <b>0.82</b> | <b>0.63</b> | <b>0.51</b> | 0.43        |
| 3000 | 13.45           | 8.52        | 6.27        | 4.97        | 2.93        | <b>1.86</b> | <b>1.42</b> | <b>1.14</b> | <b>0.96</b> |
| 4000 | 23.91           | 15.16       | 11.15       | 8.84        | 5.21        | 3.3         | <b>2.52</b> | <b>2.03</b> | <b>1.71</b> |

### 2-1/2 INCH ELIMINATOR

| #/HR | PRESSURE (PSIG) |             |             |             |             |             |             |             |             |
|------|-----------------|-------------|-------------|-------------|-------------|-------------|-------------|-------------|-------------|
|      | 25              | 50          | 75          | 100         | 200         | 300         | 400         | 500         | 600         |
| 1000 | <b>0.27</b>     | <b>0.17</b> | <b>0.12</b> | <b>0.1</b>  | 0.06        | 0.04        | 0.03        | 0.02        | 0.02        |
| 2000 | 1.07            | 0.68        | <b>0.5</b>  | <b>0.39</b> | <b>0.23</b> | 0.15        | 0.11        | 0.09        | 0.08        |
| 3000 | 2.4             | 1.52        | 1.12        | <b>0.89</b> | <b>0.52</b> | <b>0.33</b> | 0.25        | 0.2         | 0.17        |
| 4000 | 4.27            | 2.71        | 1.99        | 1.58        | <b>0.93</b> | <b>0.59</b> | <b>0.45</b> | 0.36        | 0.31        |
| 5000 | 6.68            | 4.23        | 3.11        | 2.47        | <b>1.45</b> | <b>0.92</b> | <b>0.7</b>  | <b>0.57</b> | <b>0.48</b> |
| 6000 | 9.61            | 6.09        | 4.48        | 3.55        | 2.09        | <b>1.33</b> | <b>1.01</b> | <b>0.82</b> | <b>0.69</b> |
| 7000 | 13.08           | 8.29        | 6.1         | 4.84        | 2.85        | <b>1.81</b> | <b>1.38</b> | <b>1.11</b> | <b>0.94</b> |

### 4 INCH ELIMINATOR

| #/HR  | PRESSURE (PSIG) |             |             |             |             |             |             |             |             |
|-------|-----------------|-------------|-------------|-------------|-------------|-------------|-------------|-------------|-------------|
|       | 25              | 50          | 75          | 100         | 200         | 300         | 400         | 500         | 600         |
| 4000  | 0.6             | <b>0.38</b> | <b>0.28</b> | <b>0.22</b> | 0.13        | 0.08        | 0.06        | 0.05        | 0.04        |
| 6000  | 1.34            | 0.85        | 0.63        | <b>0.5</b>  | <b>0.29</b> | 0.19        | 0.14        | 0.11        | 0.1         |
| 8000  | 2.39            | 1.51        | 1.11        | 0.88        | <b>0.52</b> | <b>0.33</b> | 0.25        | 0.2         | 0.17        |
| 10000 | 3.73            | 2.37        | 1.74        | 1.38        | <b>0.81</b> | <b>0.51</b> | <b>0.39</b> | 0.32        | 0.27        |
| 12000 | 5.37            | 3.41        | 2.51        | 1.99        | <b>1.17</b> | <b>0.74</b> | <b>0.57</b> | <b>0.46</b> | 0.38        |
| 14000 | 7.32            | 4.64        | 3.41        | 2.71        | 1.59        | <b>1.01</b> | <b>0.77</b> | <b>0.62</b> | <b>0.52</b> |
| 16000 | 9.55            | 6.06        | 4.46        | 3.53        | 2.08        | <b>1.32</b> | <b>1.01</b> | <b>0.81</b> | <b>0.68</b> |

### 3/4 INCH ELIMINATOR

| #/HR | PRESSURE (PSIG) |             |             |             |             |             |             |             |             |
|------|-----------------|-------------|-------------|-------------|-------------|-------------|-------------|-------------|-------------|
|      | 25              | 50          | 75          | 100         | 200         | 300         | 400         | 500         | 600         |
| 100  | <b>0.22</b>     | <b>0.14</b> | <b>0.1</b>  | 0.08        | 0.05        | 0.03        | 0.02        | 0.02        | 0.02        |
| 200  | 0.89            | <b>0.57</b> | <b>0.42</b> | <b>0.33</b> | <b>0.19</b> | 0.12        | 0.09        | 0.08        | 0.06        |
| 300  | 2.01            | 1.27        | 0.94        | <b>0.74</b> | <b>0.44</b> | <b>0.28</b> | 0.21        | 0.17        | 0.14        |
| 400  | 3.57            | 2.26        | 1.66        | 1.32        | <b>0.78</b> | <b>0.49</b> | <b>0.38</b> | 0.3         | 0.25        |
| 500  | 5.57            | 3.53        | 2.6         | 2.06        | <b>1.21</b> | <b>0.77</b> | <b>0.59</b> | <b>0.47</b> | 0.4         |
| 600  | 8.02            | 5.09        | 3.74        | 2.97        | 1.75        | <b>1.11</b> | <b>0.85</b> | <b>0.68</b> | <b>0.57</b> |

### 1-1/4 INCH ELIMINATOR

| #/HR | PRESSURE (PSIG) |             |             |             |             |             |             |             |             |
|------|-----------------|-------------|-------------|-------------|-------------|-------------|-------------|-------------|-------------|
|      | 25              | 50          | 75          | 100         | 200         | 300         | 400         | 500         | 600         |
| 500  | 0.69            | <b>0.44</b> | <b>0.32</b> | <b>0.26</b> | <b>0.15</b> | 0.1         | 0.07        | 0.06        | 0.05        |
| 750  | 1.56            | 0.99        | <b>0.73</b> | <b>0.58</b> | <b>0.34</b> | 0.22        | 0.16        | 0.13        | 0.11        |
| 1100 | 3.36            | 2.13        | 1.57        | 1.24        | <b>0.73</b> | <b>0.46</b> | <b>0.35</b> | 0.29        | 0.24        |
| 1250 | 4.34            | 2.75        | 2.02        | 1.6         | <b>0.95</b> | <b>0.6</b>  | <b>0.46</b> | 0.37        | 0.31        |
| 1500 | 6.25            | 3.96        | 2.91        | 2.31        | <b>1.36</b> | <b>0.86</b> | <b>0.66</b> | <b>0.53</b> | <b>0.45</b> |
| 1750 | 8.5             | 5.39        | 3.97        | 3.14        | 1.85        | <b>1.17</b> | <b>0.9</b>  | <b>0.72</b> | <b>0.61</b> |
| 2000 | 11.11           | 7.04        | 5.18        | 4.11        | 2.42        | <b>1.53</b> | <b>1.17</b> | <b>0.94</b> | <b>0.79</b> |

### 2 INCH ELIMINATOR

| #/HR | PRESSURE (PSIG) |             |             |            |             |             |             |             |             |
|------|-----------------|-------------|-------------|------------|-------------|-------------|-------------|-------------|-------------|
|      | 25              | 50          | 75          | 100        | 200         | 300         | 400         | 500         | 600         |
| 1000 | 0.54            | <b>0.34</b> | <b>0.25</b> | <b>0.2</b> | 0.12        | 0.07        | 0.06        | 0.05        | 0.04        |
| 2000 | 2.17            | 1.37        | 1.01        | <b>0.8</b> | <b>0.47</b> | <b>0.3</b>  | 0.23        | 0.18        | 0.16        |
| 3000 | 4.88            | 3.09        | 2.28        | 1.8        | <b>1.06</b> | <b>0.67</b> | <b>0.51</b> | <b>0.41</b> | 0.35        |
| 4000 | 8.67            | 5.5         | 4.04        | 3.21       | 1.89        | <b>1.2</b>  | <b>0.91</b> | <b>0.74</b> | <b>0.62</b> |
| 5000 | 13.55           | 8.59        | 6.32        | 5.01       | 2.95        | <b>1.87</b> | <b>1.43</b> | <b>1.15</b> | <b>0.97</b> |
| 6000 | 19.51           | 12.37       | 9.1         | 7.22       | 4.25        | 2.69        | <b>2.06</b> | <b>1.66</b> | <b>1.4</b>  |

### 3 INCH ELIMINATOR

| #/HR  | PRESSURE (PSIG) |             |             |             |             |             |             |             |             |
|-------|-----------------|-------------|-------------|-------------|-------------|-------------|-------------|-------------|-------------|
|       | 25              | 50          | 75          | 100         | 200         | 300         | 400         | 500         | 600         |
| 2000  | 0.45            | <b>0.28</b> | <b>0.21</b> | <b>0.17</b> | 0.1         | 0.06        | 0.05        | 0.04        | 0.03        |
| 4000  | 1.79            | 1.13        | 0.83        | <b>0.66</b> | <b>0.39</b> | <b>0.25</b> | 0.19        | 0.15        | 0.13        |
| 6000  | 4.02            | 2.55        | 1.87        | 1.49        | <b>0.88</b> | <b>0.55</b> | <b>0.42</b> | 0.34        | 0.29        |
| 8000  | 7.15            | 4.53        | 3.33        | 2.64        | 1.56        | <b>0.99</b> | <b>0.75</b> | <b>0.61</b> | <b>0.51</b> |
| 10000 | 11.17           | 7.08        | 5.21        | 4.13        | 2.43        | <b>1.54</b> | <b>1.18</b> | <b>0.95</b> | <b>0.8</b>  |
| 12000 | 16.08           | 10.19       | 7.5         | 5.95        | 3.5         | 2.22        | <b>1.69</b> | <b>1.37</b> | <b>1.15</b> |
| 14000 | 21.89           | 13.87       | 10.21       | 8.09        | 4.77        | 3.02        | <b>2.31</b> | <b>1.86</b> | <b>1.56</b> |

### 6 INCH ELIMINATOR

| #/HR  | PRESSURE (PSIG) |             |             |             |             |             |             |             |             |
|-------|-----------------|-------------|-------------|-------------|-------------|-------------|-------------|-------------|-------------|
|       | 25              | 50          | 75          | 100         | 200         | 300         | 400         | 500         | 600         |
| 5000  | <b>0.18</b>     | <b>0.11</b> | <b>0.08</b> | 0.07        | 0.04        | 0.02        | 0.02        | 0.02        | 0.01        |
| 10000 | 0.72            | 0.46        | <b>0.33</b> | <b>0.27</b> | <b>0.16</b> | 0.1         | 0.08        | 0.06        | 0.05        |
| 15000 | 1.62            | 1.02        | 0.75        | <b>0.6</b>  | <b>0.35</b> | <b>0.22</b> | 0.17        | 0.14        | 0.12        |
| 20000 | 2.87            | 1.82        | 1.34        | 1.06        | <b>0.63</b> | <b>0.4</b>  | <b>0.3</b>  | 0.24        | 0.21        |
| 25000 | 4.49            | 2.85        | 2.09        | 1.66        | <b>0.98</b> | <b>0.62</b> | <b>0.47</b> | <b>0.38</b> | 0.32        |
| 30000 | 6.46            | 4.1         | 3.01        | 2.39        | 1.41        | <b>0.89</b> | <b>0.68</b> | <b>0.55</b> | <b>0.46</b> |
| 35000 | 8.8             | 5.58        | 4.1         | 3.25        | 1.92        | <b>1.21</b> | <b>0.93</b> | <b>0.75</b> | <b>0.63</b> |

# SIZING ELIMINATOR STEAM SEPARATORS

## SIZING FOR AIR APPLICATIONS

Using your system pressure and capacity, select a size from the Pressure Drop Tables below that will yield a pressure drop in **boldface** type. This will provide the most efficient separation with velocities between 8 and 60 ft/s for sizes up to 2½" and between 8 and 50 ft/s for sizes 3" and above.

## EXAMPLE

For a system under 400 PSIG with a capacity of 500 SCFM, a 2" or 2½" separator is recommended.

- A 2" separator will provide a 0.12 PSIG pressure drop.
- A 2½" separator will provide a 0.06 PSIG pressure drop.

## ELIMINATOR PRESSURE DROP TABLES – AIR

### 1/2 INCH ELIMINATOR

| SCFM | PRESSURE (PSIG) |             |             |             |             |             |             |             |             |
|------|-----------------|-------------|-------------|-------------|-------------|-------------|-------------|-------------|-------------|
|      | 25              | 50          | 75          | 100         | 200         | 300         | 400         | 500         | 600         |
| 10   | <b>0.07</b>     | <b>0.04</b> | <b>0.03</b> | <b>0.02</b> | 0.01        | 0.01        | 0.01        | 0.01        | 0           |
| 20   | <b>0.27</b>     | <b>0.17</b> | <b>0.12</b> | <b>0.09</b> | <b>0.05</b> | 0.03        | 0.03        | 0.02        | 0.02        |
| 30   | 0.61            | <b>0.37</b> | <b>0.27</b> | <b>0.21</b> | <b>0.11</b> | <b>0.08</b> | <b>0.06</b> | 0.05        | 0.04        |
| 40   | 1.08            | 0.66        | <b>0.48</b> | <b>0.37</b> | <b>0.2</b>  | <b>0.14</b> | <b>0.1</b>  | <b>0.08</b> | 0.07        |
| 50   | 1.69            | 1.03        | 0.75        | <b>0.58</b> | <b>0.31</b> | <b>0.21</b> | <b>0.16</b> | <b>0.13</b> | <b>0.11</b> |
| 60   | 2.43            | 1.49        | 1.07        | 0.84        | <b>0.45</b> | <b>0.31</b> | <b>0.23</b> | <b>0.19</b> | <b>0.16</b> |

### 1 INCH ELIMINATOR

| SCFM | PRESSURE (PSIG) |             |             |             |             |             |             |             |             |
|------|-----------------|-------------|-------------|-------------|-------------|-------------|-------------|-------------|-------------|
|      | 25              | 50          | 75          | 100         | 200         | 300         | 400         | 500         | 600         |
| 25   | <b>0.05</b>     | <b>0.03</b> | <b>0.02</b> | 0.02        | 0.01        | 0.01        | 0           | 0           | 0           |
| 50   | <b>0.2</b>      | <b>0.12</b> | <b>0.09</b> | <b>0.07</b> | <b>0.04</b> | 0.03        | 0.02        | 0.02        | 0.01        |
| 75   | 0.45            | <b>0.28</b> | <b>0.2</b>  | <b>0.16</b> | <b>0.08</b> | <b>0.06</b> | 0.04        | 0.03        | 0.03        |
| 100  | 0.8             | 0.49        | <b>0.36</b> | <b>0.28</b> | <b>0.15</b> | <b>0.1</b>  | <b>0.08</b> | 0.06        | 0.05        |
| 125  | 1.26            | 0.77        | <b>0.56</b> | <b>0.43</b> | <b>0.23</b> | <b>0.16</b> | <b>0.12</b> | <b>0.1</b>  | <b>0.08</b> |
| 150  | 1.81            | 1.11        | 0.8         | <b>0.63</b> | <b>0.33</b> | <b>0.23</b> | <b>0.17</b> | <b>0.14</b> | <b>0.12</b> |

### 1-1/2 INCH ELIMINATOR

| SCFM | PRESSURE (PSIG) |             |             |             |             |             |             |             |             |
|------|-----------------|-------------|-------------|-------------|-------------|-------------|-------------|-------------|-------------|
|      | 25              | 50          | 75          | 100         | 200         | 300         | 400         | 500         | 600         |
| 50   | <b>0.04</b>     | <b>0.02</b> | <b>0.02</b> | 0.01        | 0.01        | 0           | 0           | 0           | 0           |
| 100  | <b>0.14</b>     | <b>0.09</b> | <b>0.06</b> | <b>0.05</b> | <b>0.03</b> | 0.02        | 0.01        | 0.01        | 0.01        |
| 150  | 0.32            | <b>0.2</b>  | <b>0.14</b> | <b>0.11</b> | <b>0.06</b> | <b>0.04</b> | 0.03        | 0.02        | 0.02        |
| 200  | 0.57            | <b>0.35</b> | <b>0.25</b> | <b>0.2</b>  | <b>0.11</b> | <b>0.07</b> | <b>0.05</b> | 0.04        | 0.04        |
| 250  | 0.89            | 0.55        | <b>0.39</b> | <b>0.31</b> | <b>0.16</b> | <b>0.11</b> | <b>0.09</b> | <b>0.07</b> | 0.06        |
| 300  | 1.28            | 0.79        | <b>0.57</b> | <b>0.44</b> | <b>0.24</b> | <b>0.16</b> | <b>0.12</b> | <b>0.1</b>  | <b>0.08</b> |

### 2-1/2 INCH ELIMINATOR

| SCFM | PRESSURE (PSIG) |             |             |             |             |             |             |             |             |
|------|-----------------|-------------|-------------|-------------|-------------|-------------|-------------|-------------|-------------|
|      | 25              | 50          | 75          | 100         | 200         | 300         | 400         | 500         | 600         |
| 100  | <b>0.03</b>     | <b>0.02</b> | <b>0.01</b> | 0.01        | 0           | 0           | 0           | 0           | 0           |
| 250  | <b>0.16</b>     | <b>0.1</b>  | <b>0.07</b> | <b>0.06</b> | <b>0.03</b> | 0.02        | 0.02        | 0.01        | 0.01        |
| 500  | 0.64            | <b>0.39</b> | <b>0.28</b> | <b>0.22</b> | <b>0.12</b> | <b>0.08</b> | <b>0.06</b> | 0.05        | 0.04        |
| 750  | 1.43            | 0.88        | 0.63        | <b>0.5</b>  | <b>0.26</b> | <b>0.18</b> | <b>0.14</b> | <b>0.11</b> | <b>0.09</b> |
| 1000 | 2.54            | 1.56        | 1.13        | 0.88        | <b>0.47</b> | <b>0.32</b> | <b>0.24</b> | <b>0.2</b>  | <b>0.16</b> |
| 1250 | 3.97            | 2.44        | 1.76        | 1.38        | <b>0.73</b> | <b>0.5</b>  | <b>0.38</b> | <b>0.31</b> | <b>0.26</b> |

### 4 INCH ELIMINATOR

| SCFM | PRESSURE (PSIG) |             |             |             |             |             |             |             |             |
|------|-----------------|-------------|-------------|-------------|-------------|-------------|-------------|-------------|-------------|
|      | 25              | 50          | 75          | 100         | 200         | 300         | 400         | 500         | 600         |
| 250  | <b>0.02</b>     | <b>0.01</b> | 0.01        | 0.01        | 0           | 0           | 0           | 0           | 0           |
| 500  | <b>0.09</b>     | <b>0.05</b> | <b>0.04</b> | <b>0.03</b> | 0.02        | 0.01        | 0.01        | 0.01        | 0.01        |
| 1000 | 0.36            | <b>0.22</b> | <b>0.16</b> | <b>0.12</b> | <b>0.07</b> | <b>0.04</b> | 0.03        | 0.03        | 0.02        |
| 1500 | 0.8             | 0.49        | <b>0.35</b> | <b>0.28</b> | <b>0.15</b> | <b>0.1</b>  | <b>0.08</b> | <b>0.06</b> | 0.05        |
| 2000 | 1.42            | 0.87        | 0.63        | <b>0.49</b> | <b>0.26</b> | <b>0.18</b> | <b>0.14</b> | <b>0.11</b> | <b>0.09</b> |
| 2500 | 2.22            | 1.36        | 0.98        | 0.77        | <b>0.41</b> | <b>0.28</b> | <b>0.21</b> | <b>0.17</b> | <b>0.14</b> |

### 3/4 INCH ELIMINATOR

| SCFM | PRESSURE (PSIG) |             |             |             |             |             |             |             |             |
|------|-----------------|-------------|-------------|-------------|-------------|-------------|-------------|-------------|-------------|
|      | 25              | 50          | 75          | 100         | 200         | 300         | 400         | 500         | 600         |
| 10   | <b>0.02</b>     | <b>0.01</b> | 0.01        | 0.01        | 0           | 0           | 0           | 0           | 0           |
| 25   | <b>0.13</b>     | <b>0.08</b> | <b>0.06</b> | <b>0.05</b> | 0.02        | 0.02        | 0.01        | 0.01        | 0.01        |
| 50   | 0.53            | <b>0.33</b> | <b>0.23</b> | <b>0.18</b> | <b>0.1</b>  | <b>0.07</b> | 0.05        | 0.04        | 0.03        |
| 70   | 1.04            | 0.64        | <b>0.46</b> | <b>0.36</b> | <b>0.19</b> | <b>0.13</b> | <b>0.1</b>  | <b>0.08</b> | 0.07        |
| 90   | 1.72            | 1.05        | 0.76        | <b>0.59</b> | <b>0.32</b> | <b>0.22</b> | <b>0.16</b> | <b>0.13</b> | <b>0.11</b> |
| 110  | 2.57            | 1.58        | 1.14        | 0.89        | <b>0.47</b> | <b>0.32</b> | <b>0.25</b> | <b>0.2</b>  | <b>0.17</b> |

### 1-1/4 INCH ELIMINATOR

| SCFM | PRESSURE (PSIG) |             |             |             |             |             |             |             |             |
|------|-----------------|-------------|-------------|-------------|-------------|-------------|-------------|-------------|-------------|
|      | 25              | 50          | 75          | 100         | 200         | 300         | 400         | 500         | 600         |
| 50   | <b>0.07</b>     | <b>0.04</b> | <b>0.03</b> | <b>0.02</b> | 0.01        | 0.01        | 0.01        | 0.01        | 0           |
| 100  | <b>0.26</b>     | <b>0.16</b> | <b>0.12</b> | <b>0.09</b> | <b>0.05</b> | 0.03        | 0.03        | 0.02        | 0.02        |
| 150  | 0.59            | <b>0.37</b> | <b>0.26</b> | <b>0.21</b> | <b>0.11</b> | <b>0.08</b> | <b>0.06</b> | 0.05        | 0.04        |
| 200  | 1.06            | 0.65        | <b>0.47</b> | <b>0.37</b> | <b>0.2</b>  | <b>0.13</b> | <b>0.1</b>  | <b>0.08</b> | 0.07        |
| 250  | 1.65            | 1.01        | 0.73        | <b>0.57</b> | <b>0.31</b> | <b>0.21</b> | <b>0.16</b> | <b>0.13</b> | <b>0.11</b> |
| 300  | 2.38            | 1.46        | 1.05        | 0.82        | <b>0.44</b> | <b>0.3</b>  | <b>0.23</b> | <b>0.18</b> | <b>0.15</b> |

### 2 INCH ELIMINATOR

| SCFM | PRESSURE (PSIG) |             |             |             |             |             |             |             |             |
|------|-----------------|-------------|-------------|-------------|-------------|-------------|-------------|-------------|-------------|
|      | 25              | 50          | 75          | 100         | 200         | 300         | 400         | 500         | 600         |
| 100  | <b>0.05</b>     | <b>0.03</b> | <b>0.02</b> | <b>0.02</b> | 0.01        | 0.01        | 0           | 0           | 0           |
| 200  | <b>0.21</b>     | <b>0.13</b> | <b>0.09</b> | <b>0.07</b> | <b>0.04</b> | 0.03        | 0.02        | 0.02        | 0.01        |
| 300  | 0.46            | <b>0.29</b> | <b>0.21</b> | <b>0.16</b> | <b>0.09</b> | <b>0.06</b> | 0.04        | 0.04        | 0.03        |
| 400  | 0.83            | 0.51        | <b>0.37</b> | <b>0.29</b> | <b>0.15</b> | <b>0.1</b>  | <b>0.08</b> | <b>0.06</b> | 0.05        |
| 500  | 1.29            | 0.79        | <b>0.57</b> | <b>0.45</b> | <b>0.24</b> | <b>0.16</b> | <b>0.12</b> | <b>0.1</b>  | <b>0.08</b> |
| 600  | 1.86            | 1.14        | 0.82        | <b>0.64</b> | <b>0.34</b> | <b>0.23</b> | <b>0.18</b> | <b>0.14</b> | <b>0.12</b> |

### 3 INCH ELIMINATOR

| SCFM | PRESSURE (PSIG) |             |             |             |             |             |             |             |            |
|------|-----------------|-------------|-------------|-------------|-------------|-------------|-------------|-------------|------------|
|      | 25              | 50          | 75          | 100         | 200         | 300         | 400         | 500         | 600        |
| 200  | <b>0.04</b>     | <b>0.03</b> | <b>0.02</b> | <b>0.01</b> | 0.01        | 0.01        | 0           | 0           | 0          |
| 400  | <b>0.17</b>     | <b>0.1</b>  | <b>0.08</b> | <b>0.06</b> | <b>0.03</b> | 0.02        | 0.02        | 0.01        | 0.01       |
| 600  | 0.38            | <b>0.23</b> | <b>0.17</b> | <b>0.13</b> | <b>0.07</b> | <b>0.05</b> | 0.04        | 0.03        | 0.02       |
| 800  | 0.68            | 0.42        | <b>0.3</b>  | <b>0.24</b> | <b>0.13</b> | <b>0.09</b> | <b>0.07</b> | 0.05        | 0.04       |
| 1000 | 1.06            | 0.65        | 0.47        | <b>0.37</b> | <b>0.2</b>  | <b>0.13</b> | <b>0.1</b>  | <b>0.08</b> | 0.07       |
| 1200 | 1.53            | 0.94        | 0.68        | <b>0.53</b> | <b>0.28</b> | <b>0.19</b> | <b>0.15</b> | <b>0.12</b> | <b>0.1</b> |

### 6 INCH ELIMINATOR

| SCFM | PRESSURE (PSIG) |             |             |             |             |             |             |             |             |
|------|-----------------|-------------|-------------|-------------|-------------|-------------|-------------|-------------|-------------|
|      | 25              | 50          | 75          | 100         | 200         | 300         | 400         | 500         | 600         |
| 500  | <b>0.02</b>     | <b>0.01</b> | 0.01        | 0.01        | 0           | 0           | 0           | 0           | 0           |
| 1000 | <b>0.07</b>     | <b>0.04</b> | <b>0.03</b> | <b>0.02</b> | 0.01        | 0.01        | 0.01        | 0.01        | 0           |
| 2000 | 0.27            | <b>0.17</b> | <b>0.12</b> | <b>0.09</b> | <b>0.05</b> | 0.03        | 0.03        | 0.02        | 0.02        |
| 3000 | 0.62            | 0.38        | <b>0.27</b> | <b>0.21</b> | <b>0.11</b> | <b>0.08</b> | <b>0.06</b> | 0.05        | 0.04        |
| 4000 | 1.09            | 0.67        | 0.48        | <b>0.38</b> | <b>0.2</b>  | <b>0.14</b> | <b>0.1</b>  | <b>0.08</b> | 0.07        |
| 5000 | 1.71            | 1.05        | 0.76        | 0.59        | <b>0.32</b> | <b>0.22</b> | <b>0.16</b> | <b>0.13</b> | <b>0.11</b> |