

LIQUIDATOR UMT-TD Series Thermodynamic Steam Trap

Applications

- Unit Heaters
- Steam Tracing
- Drip Legs
- Tire Presses
- Laundry Equipment
- Plating Tanks
- Platen Presses
- Cooking Equipment

Pressures To 450 PSIG
Temperatures to 650°F

Easily Maintained

Four bolt cover permits easy in-line rebuilding for less than the cost of replacement.

Optional Integral Strainer

Helps prevent dirt and scale build-up on valve seat.

Excellent Energy Savings

Positive shutoff assures no loss of steam during normal operation.

Fits all Universal Connectors

Liquidator body will replace any manufacturers' universal mount trap body.

Easily Replaced

Two bolt design permits rapid removal without breaking pipe connections.

Freeze Proof

Self draining when installed vertically.

Durability and Long Service Life

Stainless steel body and cover with stainless steel Celtron® Cartridge for maximum corrosion, thermal and hydraulic shock resistance.

Unaffected by Ambient Conditions

Steam jacketing minimizes steam loss.

Blast Discharge

Clears away dirt and scale.

3 Year Guarantee

Guaranteed against defects in material and workmanship.

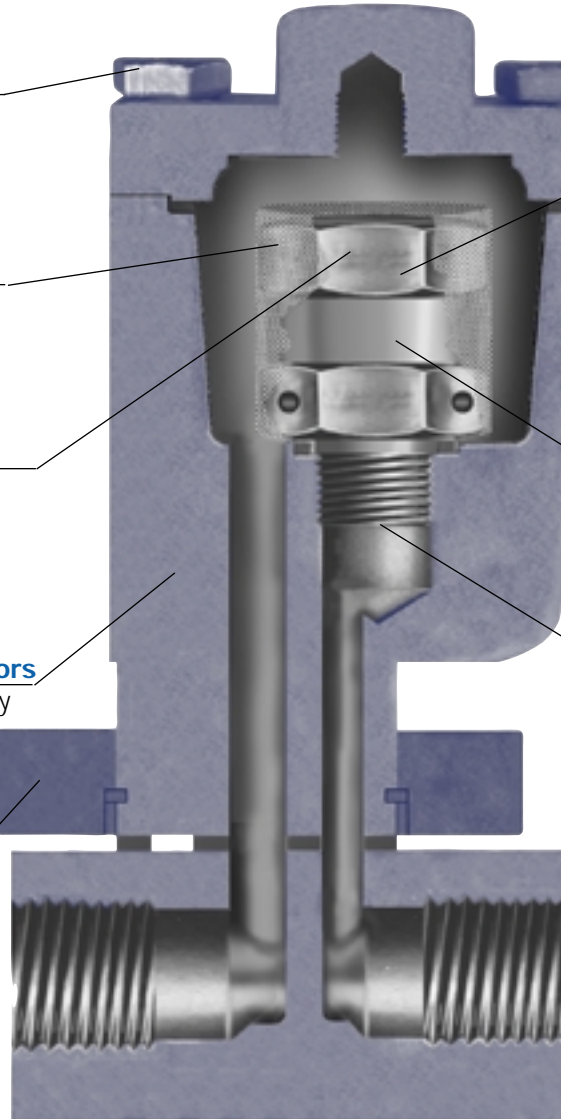

THERMODYNAMIC STEAM TRAPS

NICHOLSON has a wide variety of Thermodynamic Steam Traps to accommodate applications through 600 psi. Most models utilize **NICHOLSON**'s exclusive Celtron® Cartridge. The Celtron® facilitates inline maintenance while simultaneously providing superior performance. The all-stainless NTD 600 is the value leader of the line, providing the performance **NICHOLSON** users have come to expect in a conventional, recognizable design.



NTD600 SERIES THERMODYNAMIC STEAM TRAPS

Pressures To 600 PSIG (41.3 barg)
Temperatures to 800°F (426°C)

Compact Design — Hardened stainless steel disc is the only moving part.

Inexpensive — Low initial cost is less expensive than repairable technologies.

Simplifies Installation — Works in any position.

Rugged — Handles water hammer and superheat.

Reliable, Efficient Operation — Blast discharge helps to eliminate dirt buildup and provides tight shutoff

Freeze resistant — Self draining design prevents freezing.

All Stainless Steel Construction — Resists both internal and external corrosion.

Easy to Monitor — Audible discharge cycle makes checking operation simple.

MODELS

- **NTD600**—Thermodynamic Disc Trap
- **NTD600S**—NTD600 with integral strainer
- **NTD600B**—NTD600S with blowdown valve

APPLICATIONS

- Steam Tracing
- Drips
- Heating

NTD600 Model Only:
Canadian Registration # OE0591.9C

Installation Tip: Always install STV Test & Block Valve as part of trap station
SEE PAGE 118

Installation Tip: Add Uniflex Pipe Coupling for ease of maintenance
SEE PAGE 102

OPERATION

Incoming air and condensate flow through the trap body and into the control chamber. Line pressure raises the disc off the seat allowing complete discharge. When flashing condensate enters the cartridge, flow velocity increases, creating low pressure underneath the disc. Flashing condensate at high velocity strikes the inside wall of the disc chamber and is deflected

to the top of the disc causing a pressure buildup. The disc is forced down onto the seat by this pressure imbalance. The trap remains closed as flashed vapor in the control chamber keeps the disc seated. Pressure inside the cap is not lowered until the trapped flash vapor condenses due to body radiation. Condensing steam lowers the pressure above the disc. Disc is then lifted and the cycle repeated.

NTD600 SERIES THERMODYNAMIC STEAM TRAPS

SPECIFICATION

Steam trap shall be of thermodynamic design. Body shall be of all stainless construction and hardened throughout. Seat shall be integral to body. Cover shall seal to body without gaskets or seals. Trap shall be suitable for pressures through 600 psi and available in 3/8" through 1".

MAXIMUM OPERATING CONDITIONS

PMO: Max. Operating Pressure	600 psig	(41.3 barg)
TMO: Max. Operating Temperature	800°F	(426°C)
PMA: Max. Allowable Pressure	600 psig	(41.3 barg)
TMA: Max. Allowable Temperature	800°F	(426°F)

MATERIALS OF CONSTRUCTION

Body	420F SS ASTM A743 CA40F
Cap & Disc	416 SS ASTM A582
Blow Down Valve	304/316SS
Screen	Stainless Steel

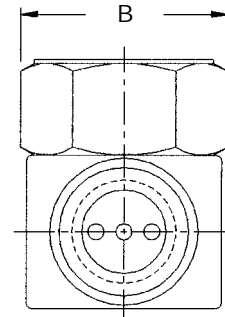
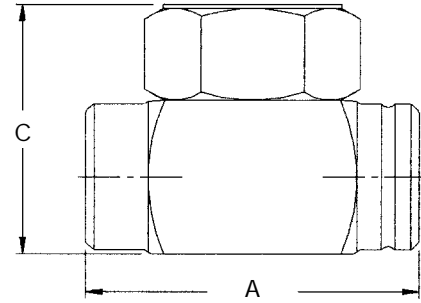

Connections: 3/8" - 1" NPT

Size	Dimensions in inches (mm)			Weight in Lbs. (kg)
	A	B	C	
3/8"	2 (51)	1 3/4 (44)	1 3/4 (44)	.8 (.36)
1/2"	2 11/16 (68)	1 3/4 (44)	2 (51)	1.2 (.55)
3/4"	2 13/16 (71)	2 5/16 (59)	2 7/16 (62)	1.85 (.86)
1"	3 5/16 (84)	2 1/2 (64)	2 7/8 (73)	3.1 (1.8)

Maximum Capacity—lbs/hr 10°F Below Saturation														
NPT Connection	Differential PSIG (barg)													
	3.5 (0.24)	5 (0.34)	10 (0.7)	20 (1.4)	30 (2.1)	50 (3.4)	75 (5.2)	100 (6.9)	150 (10.3)	200 (13.8)	300 (20.7)	400 (27.6)	500 (34.5)	600 (41.3)
3/8"	180	185	190	200	215	245	305	370	500	610	790	960	1100	1250
1/2"	300	310	345	410	465	575	700	810	1000	1140	1410	1630	1830	2000
3/4"	405	420	470	560	640	810	1000	1160	1450	1670	2100	2430	2750	3050
1"	640	670	725	865	980	1200	1470	1750	2200	2600	3250	3780	4250	4700

For Kg/Hr Multiply by .454

NOTE: The NTD600 Series works efficiently at all line pressures between 5+600 psi and back pressures up to 80% of line pressures.

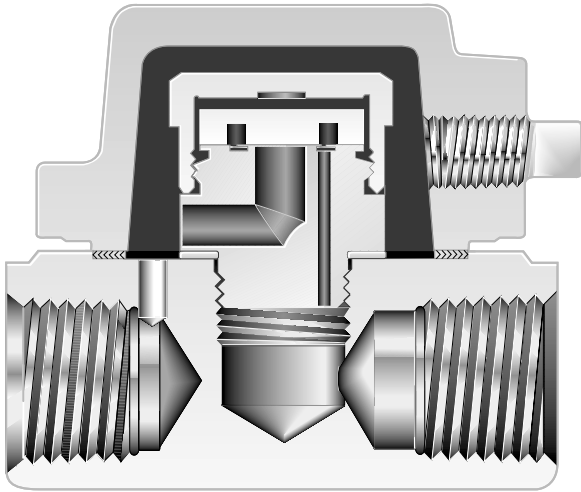

Shown with optional
tapped blowdown connection.

APPLICATIONS

- Steam Tracing
- Drips
- Heating

OPTIONS

- SW - Socketweld Connections
- TB - Tapped Blowdown Connection
- B - Blowdown Valve

Canadian Registration # 0E0591.9

S610 SERIES THERMODYNAMIC STEAM TRAP

Pressures To 600 PSIG (41.3 barg)
Temperatures to 800°F (426°C)

Improved Energy Savings — Lowers steam waste due to steam jacketing. Trap cycle is unaffected by ambient temperatures or precipitation.

Extended Trap Life — Integral strainer keeps disc and seat clean. Non-violent discharge reduces wear. Heavy disc prevents warpage and improves performance.

Easily Maintained — Completely renewable without disturbing piping connections by removing cover, unscrewing and replacing Celtron® cartridge. Celtron® replacement cartridges are packaged individually with cover and gaskets in a protective bag.

Freeze Proof — When mounted vertically or on its side horizontally.

Multi-functional — Integral check valve eliminates need for additional fittings.

Economical — First cost and maintenance cost are low.

Spiral-wound Cover Gasket — assures positive closure.

Integral Strainer — prevents dirt problems.

MODELS

- S610—3/8" & 1/2" standard capacity
- S610L—Low capacity on S610



Celtron®

plastic-packed
replaceable cartridge
for fast and simple
replacement



OPERATION

Incoming air and condensate flow through the trap body and into the Celtron® cartridge. Line pressure raises the disc off the seat allowing complete discharge. When flashing condensate enters the cartridge, flow velocity increases, creating low pressure underneath the disc. Flashing condensate at high velocity strikes the inside wall of the disc chamber and is deflected

to the top of the disc causing a pressure buildup. The disc is forced down onto the seat by this pressure imbalance. The trap remains closed as steam in the jacket prevents exposure of the Celtron® cartridge to ambient temperatures. Pressure inside the cap is not lowered until the trapped flash vapor condenses. Condensing steam lowers the pressure above the disc. Disc is then lifted and the cycle repeated.

S610 SERIES THERMODYNAMIC STEAM TRAP

SPECIFICATION

Steam trap shall be of thermodynamic cartridge design. Body shall be of forged carbon steel construction housing stainless steel Celtron cartridge. Celtron cartridge shall contain all working components. Cartridge shall be hardened throughout. Seat shall be stress relieved to eliminate warpage. Trap shall contain integral strainer with available blowdown port and valve. Cover shall seal to body utilizing spiral wound graphite gasket. Trap shall be suitable for pressures through 600 psi and available in 3/8" through 1/2".

MAXIMUM OPERATING CONDITIONS

PMO: Max. Operating Pressure 600 psig (41.3 barg)
 TMO: Max. Operating Temperature 800°F (426°C)
 PMA: Max. Allowable Pressure 650 psig (44.8 barg)
 TMA: Max. Allowable Temperature 800°F (426°C)

MATERIALS OF CONSTRUCTION

Body & Cover:ASTM A105 Forged Steel
 Celtron® Cartridge416 SS w/Hardened Disc & Seat
 Cover Gasket304 SS Spiral Wound w/Graphite Fill
 Bolts:High Temperature Alloy
 Integral Strainer:304 Stainless Steel

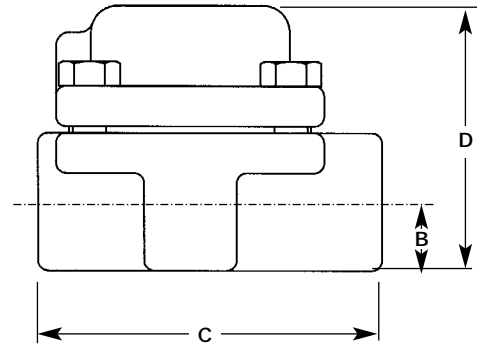
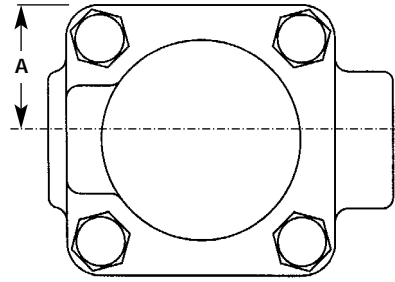

Connections:
3/8"-1/2" NPT or Socketweld

Dimensions in inches (mm)					Weight in Lbs. (kg).
Size	A	B	C	D	
3/8" - 1/2"	1 ¹⁷ / ₆₄ (32)	2 ¹ / ₃₂ (17)	3 ¹ / ₄ (83)	2 ¹⁵ / ₃₂ (63)	2.3 lbs (1.05)

Maximum Capacity—lbs/hr 10°F Below Saturation											
NPT Threaded or Socketweld Connections	Trap	Differential - PSIG (barg)									
		5 (0.34)	10 (0.7)	25 (1.7)	50 (3.4)	75 (5.2)	100 (6.9)	200 (13.8)	300 (20.7)	400 (27.6)	600 (41.3)
3/8" - 1/2"	S610L	105	150	235	330	395	435	550	630	690	790
3/8" - 1/2"	S610	240	265	420	590	700	770	980	1120	1240	1400

For Kg/Hr Multiply by .454

The S610 Series trap works efficiently at all line pressures between 5 and 600 psi and back pressures to 80% of line pressure.



Shown with optional blowdown valve

APPLICATIONS

- Steam Tracing
- Drips
- Heating

OPTIONS

- B - Blowdown Valve
- SW - Socketweld Connections

Canadian Registration # 0E0591.9

S650 SERIES THERMO-ACTIVE STEAM TRAP

Pressures To 600 PSIG (41.3 barg)
Temperatures to 800°F (427°C)

Space Saving — Design incorporates a built-in strainer and optional blowdown valve. Eliminates four connections and four fittings.

Improved Energy Savings — Lowers steam waste due to steam jacketing. Trap cycling is unaffected by ambient temperatures.

Non-violent Discharge — Soft discharge which is unique in a steam trap of this type.

Easily Maintained — Completely renewable without disturbing piping connections by removing cover, unscrewing and replacing Celtron® cartridge. Celtron® replacement cartridges are packaged individually with cover and gaskets in a protective bag. Optional blowdown valve permits easy strainer cleaning while in service.

Freeze Proof — When mounted vertically or on its side horizontally.

Low in Cost — Purchase and maintenance costs are low.

Models

- **S650**—Y pattern body with screen and blowdown port tapped and plugged
- **S650L**—Low capacity on S650

Celtron®

plastic-packed
replaceable cartridge
for fast and simple
replacement



OPERATION

Incoming air and condensate flow through the trap body and into the Celtron® cartridge. Line pressure raises the disc off the seat allowing complete discharge. When flashing condensate enters the cartridge, flow velocity increases, creating low pressure underneath the disc. Flashing condensate at high velocity strikes the inside wall of the disc chamber and is deflected

to the top of the disc causing a pressure buildup. The disc is forced down onto the seat by this pressure imbalance. The trap remains closed as steam in the jacket prevents exposure of the Celtron® cartridge to ambient temperatures. Pressure inside the cap is not lowered until the trapped flash vapor condenses. Condensing steam lowers the pressure above the disc. Disc is then lifted and the cycle repeated.

S650 SERIES THERMO-ACTIVE STEAM TRAP

SPECIFICATION

Steam trap shall be of thermodynamic cartridge design. Body shall be of forged carbon steel construction housing stainless steel Celtron cartridge. Celtron cartridge shall contain all working components. Cartridge shall be hardened throughout. Seat shall be stress relieved to eliminate warpage. Trap shall contain integral Y pattern strainer with available blowdown valve. Cover shall seal to body utilizing spiral wound graphite gasket. Trap shall be suitable for pressures through 600 psi and available in 1/2"-3/4" NPT.

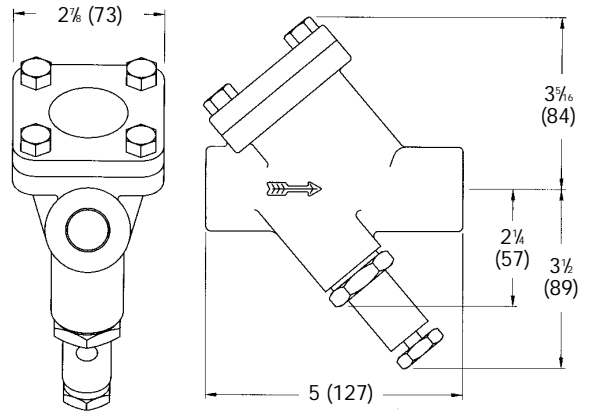

**DIMENSIONS IN INCHES (MM)
SHOWN WITH OPTIONAL BLOWDOWN VALVE
WEIGHT: 5 LBS. (2.3 KG)**

Connections:
1/2" or 3/4" NPT or socketweld

MAXIMUM OPERATING CONDITIONS

PMO: Max. Operating Pressure 600 psig (41.3 barg)
 TMO: Max. Operating Temperature 800°F (426°C)
 PMA: Max. Allowable Pressure 650 psig (44.8 barg)
 TMA: Max. Allowable Temperature 800°F (426°C)

MATERIALS OF CONSTRUCTION

Body & CoverASTM A105 Forged Steel
 Celtron® Cartridge416 SS w/Hardened Disc & Seat
 Cover Gasket304 SS Spiral Wound w/Graphite Fill
 Strainer033 perf. 304 Stainless Steel
 Blowdown Valve416 Stainless Steel

Maximum Capacity—lbs/hr 10°F Below Saturation (Kg/hr 5°C Below Saturation)										
Trap	Differential PSIG (barg)									
	5 (0.34)	10 (0.7)	25 (1.7)	50 (3.5)	75 (5.2)	100 (6.9)	200 (13.8)	300 (20.7)	400 (27.6)	600 (41.3)
S650L	105	150	235	330	395	435	550	630	690	790
S650	240	265	420	590	700	770	980	1120	1240	1400

For Kg/Hr Multiply by .454

LIQUIDATOR UMT-TD

UNIVERSAL MOUNT

THERMODYNAMIC STEAM TRAPS



UMT-TD SERIES TRAP AND UMTC CONNECTOR

APPLICATIONS

- Steam Tracing
- Drips
- Light Process

OPTIONS

- SW - Socketweld Connections
- B - Blowdown Valve

Canadian Registration # 0E13886

For information on Big Block UMTVS-BB Connector
SEE PAGE 116

Celtron®
plastic-packed
replaceable cartridge
for fast and simple
replacement



OPERATION

Incoming air and condensate flow through the trap body and into the Celtron® cartridge. Line pressure raises the disc off the seat allowing complete discharge. When flashing condensate enters the cartridge, flow velocity increases, creating low pressure underneath the disc. Flashing condensate at high velocity strikes the inside wall of the disc chamber and is

Pressures To 450 PSIG (31 barg)
Temperatures to 650°F (343°C)

Easily Maintained — Universal two bolt swivel mounting simplifies removal from system. Kits allow flexibility to replace or rebuild.

Simple Installation — Stainless mounting block mounts permanently into system. Trap installs via two bolt universal connection.

Improved Energy Savings — Lowers steam waste due to steam jacketing. Trap cycle is unaffected by ambient temperatures or precipitation.

Extended Trap Life — Integral strainer keeps disc and seat clean. Non-violent discharge reduces wear. Heavy disc prevents warpage and improves performance.

Easily Maintained — Completely renewable without disturbing piping connections by removing cover, unscrewing and replacing Celtron® cartridge. Celtron® replacement cartridges are packaged individually with cover and gaskets in a protective bag.

Freeze Proof — When mounted vertically or on its side horizontally.

Multi-functional — Integral check valve eliminates need for additional fittings.

Economical — First cost and maintenance cost are low.

MODELS

- UMT-TD10L—Low Capacity Trap
- UMT-TD10—Standard Capacity Trap
- UMTC—Standard connector (1/2" & 3/4" only)
- UMTCY—Connector w/Y strainer
- UMTCYR—Right Hand Connector w/Y strainer
- UMTCYL—Left Hand Connector w/Y strainer
- UMTVS-BB—Connector with Isolation Valves, Strainer, Blowdown Valve and Test Port

For complete unit, order trap and connector as separate items.

deflected to the top of the disc causing a pressure buildup. The disc is forced down onto the seat by this pressure imbalance. The trap remains closed as steam in the jacket prevents exposure of the Celtron® cartridge to ambient temperatures. Pressure inside the cap is not lowered until the trapped flash vapor condenses. Condensing steam lowers the pressure above the disc. Disc is then lifted and the cycle repeated.

LIQUIDATOR UMT-TD

UNIVERSAL MOUNT

THERMODYNAMIC STEAM TRAPS

SPECIFICATION

Steam trap shall be of a thermodynamic capsule design. The body shall be of a 304 stainless steel 2 bolt universal swivel construction with a stainless steel in line renewable Celtron capsule. Celtron capsule shall contain all working components. Capsule shall be hardened throughout. Seat shall be stress relieved to eliminate warping. Trap shall seal to body with spiral wound graphite gaskets. Trap shall be suitable for pressures through 450 psi and available in 1/2" through 1" NPT or socketweld connections.

MAXIMUM OPERATING CONDITIONS

PMO: Max. Operating Pressure	450 psig	(31 barg)
TMO Max. Operating Temperature	650°F	(343°C)
PMA: Max. Allowable Pressure	450 psig	(31 barg)
TMA: Max. Allowable Temperature	650°F	(343°C)

MATERIALS OF CONSTRUCTION

Body & Cover: ASTM A351 Grade CF8 (304)
 Cover Gasket: 304 stainless spiral wound w/graphite fill
 Celtron® Cartridge: 416 Stainless Steel w/hardened disc & seat
 Strainer: (.033 perf.) 304 Stainless Steel
 Mounting Block: ASTM A351 Grade CF8 (304)

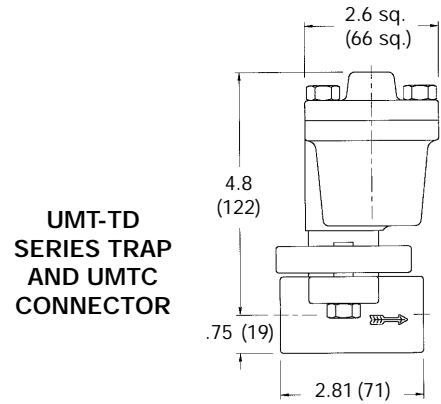

Connections:
1/2", 3/4" or 1" NPT or socketweld

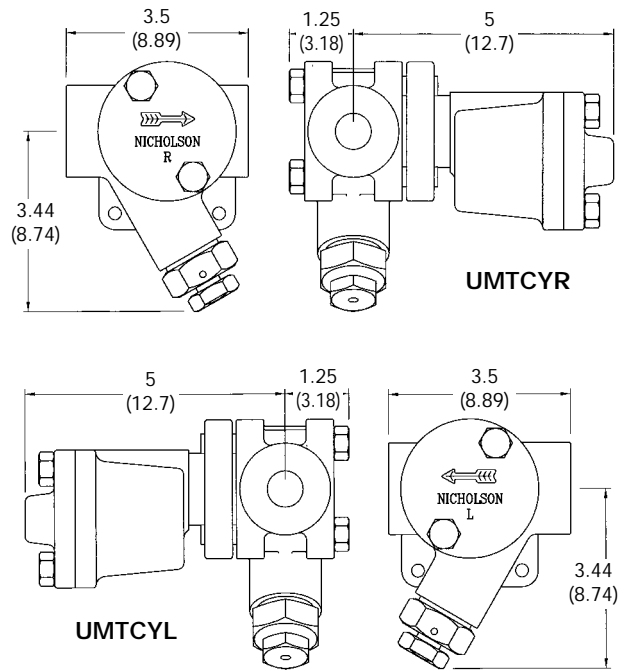

DIMENSIONS - INCHES (MM)
WEIGHT
 TRAP - 3.2 LBS. (1.4 KG)
 STD. MOUNTING BLOCK - 1.1 LBS. (0.5 KG)
 Y STRAINER MOUNTING BLOCK - 2.3 LBS. (1.0 KG)

Maximum Capacity—lbs/hr 10°F Below Saturation										
Trap	Differential – PSIG (barg)									
	5 (0.34)	10 (0.7)	25 (1.7)	50 (3.4)	75 (5.2)	100 (6.9)	200 (13.8)	300 (20.7)	400 (27.6)	450 (31)
UMT-TD10L	105	150	235	330	395	435	550	630	690	715
UMT-TD10	240	265	420	590	700	770	980	1120	1240	1280

For Kg/Hr Multiply by .454

The UMT-TD Series trap works efficiently at all line pressures between 5 and 450 psi and back pressures to 80% of line pressure.