

NOVA NFT250 Series Variable Orifice Steam Traps

*Pressures To 250 PSIG
Temperatures to 450°F*

Applications

- Steam Lines
- Process Equipment
- Steam Cookers
- Steam Heated Vats
- Pressing Machinery
- Unit Heaters
- Oil Preheaters
- Converters
- Coils
- Rotating Drum

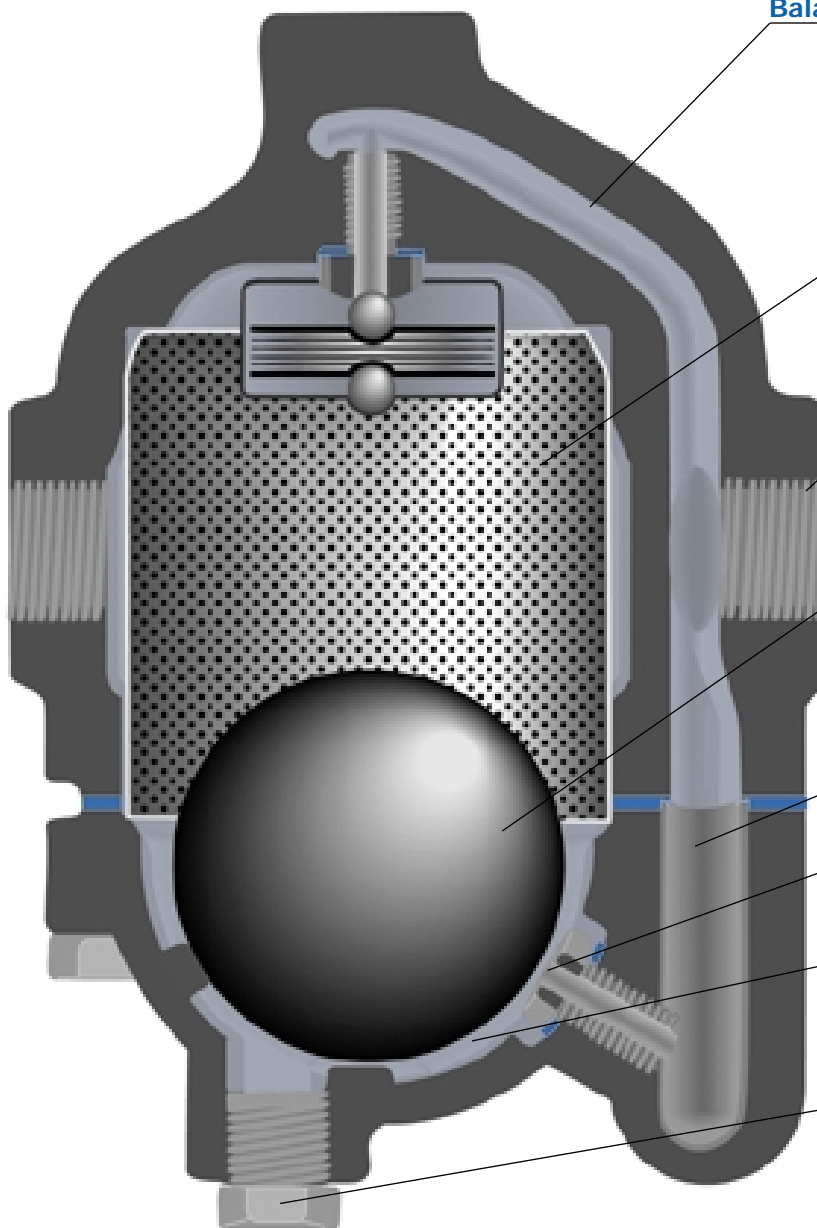

Proven Caged Stainless Steel Balanced Pressure Thermostatic Air Vent

automatically discharges air and non-condensables

Stainless Steel Strainer

with large screen area prevents dirt problems

Connections

Sizes 1/2" - 2" screwed
NPT (BSPT optional)
Sizes 1 1/2" & 2" flanged
ANSI 250

Weighted Stainless Steel Free Float Ball

multi-contact surface area modulates orifice discharge to provide smooth, continuous discharge and immediate response to load variations

Stainless Steel Sleeve

eliminates body erosion

Stainless Steel Seat

full bore prevents choking and permits ample capacities

Liquid Level

maintains seal over orifice to prevent live steam loss

Bottom & Side Blowdown Connections

for preventative maintenance

Guarantee

Traps are guaranteed against defects in materials or workmanship for 3 years.

Applications

- Steam Lines
- Process Equipment
- Steam Cookers
- Steam Heated Vats
- Pressing Machinery
- Unit Heaters
- Oil Preheaters
- Converters
- Coils
- Rotating Drum

DURA-FLO Inverted Bucket Steam Trap

*Pressures To 250 PSIG
Temperatures to 450°F*

Easy to Maintain

Working parts lift out with top for quick inspection and maintenance.

Resists Corrosion

Stainless steel bucket provides maximum service life with minimum deterioration.

Minimizes Effects of Water Hammer

Open bucket design avoids collapse typical of sealed floats.

Suitable for Wide Variety of Loads/Applications

Horizontal and vertical models in thirteen body sizes are one of the most comprehensive inverted bucket trap lines available.

Withstands Severe Conditions

Heavy wall cast iron cover and body provide many years of trouble free service.

Smooth Action and Tight Shutoff

Stainless steel linkage, valve and seats are precision manufactured to insure optimal performance.

Ideal for "Dirty" Systems

Valve and seat located at top of trap and stainless steel strainers available on most horizontal models ensure long service.

Maximum Compatibility with Existing Installations

Pressure change assemblies are interchangeable with Armstrong which guarantees maximum flexibility when stocking repair parts.



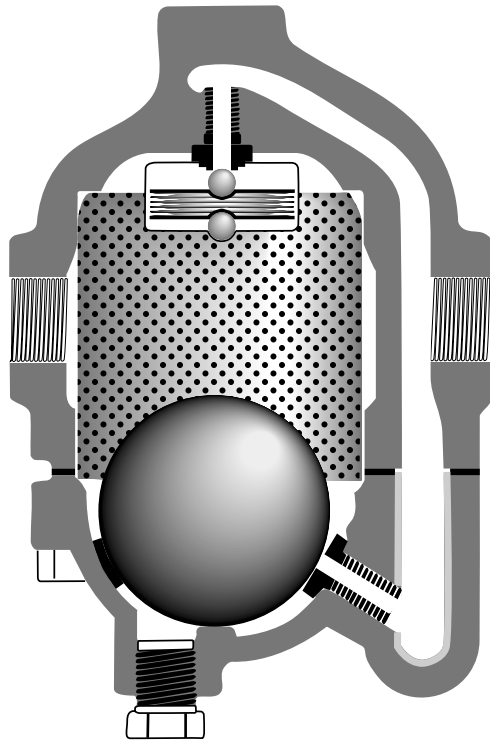

NOVA NFT250 SERIES

VARIABLE ORIFICE STEAM TRAPS

Pressures To 250 PSIG (17.2 barg)
Temperatures to 450°F (232°C)

All Stainless Steel Internal Components — Hardened valves and seats. Extra long life and dependable service. Resists water hammer. Protects against erosion and corrosion.

Erosion Proof — Discharge passage is protected with a stainless steel liner.

Integral Strainer — Stainless Steel screen prevents dirt problems. Blow-down connection provided.

Thermostatic Air Vent — Full balanced pressure element for immediate and complete air venting.

Variable Orifice — Condensate is discharged continuously through the seat ring which is modulated by the float. This provides a smooth, even flow without high velocity or steam entrainment.

SLR Orifice — Optional continuous bleed prevents flash steam lockup when it is impossible to install trap at low point in system.

Guarantee — Traps are guaranteed against defects in materials or workmanship for 3 years.

APPLICATIONS

- Steam Lines
- Process Equipment
- Steam Cookers
- Steam Heated Vats
- Pressing Machinery
- Unit Heaters
- Oil Preheaters
- Converters
- Coils
- Rotating Drum

OPTIONS *See Page 9*

- SLR - SLR Orifice
- B - Blowdown Valve (contact factory)
- Orifice Continuous Bleed Air Vent
- 250# - 250# Flanged Connection* (Flat Faced)

*Available on NFT 253 only.

Canadian Registration # OE0591.9C

MODELS

- **NFT250**—Low capacity
- **NFT251**—Medium capacity
- **NFT252**—High capacity
- **NFT253**—Super high capacity

Installation Tip: Always install STV Test & Block Valve as part of trap station
SEE PAGE 118

Installation Tip: Add Uniflex Pipe Coupling for ease of maintenance
SEE PAGE 102

OPERATION

On startup, the thermostatic air vent (caged stainless welded bellows) is open, allowing air to flow freely through the vent valve orifice. When condensate flows into the trap, the float rises, allowing condensate to be discharged. Once air and non-condensibles have been evacuated, hot condensate will cause the thermostatic vent to close. Condensate will continue to be discharged as long as condensation occurs.

During normal operation, an increase in the load causes the liquid level in the trap to rise. The float then rises and rolls off the seat ring, allowing more condensate to flow out. The float sinks as the condensate load decreases, moving nearer to the seat ring, decreasing the effective size of the orifice and allowing less condensate to discharge. This provides smooth, continuous operation that reacts instantly to load variation while maintaining a water seal over the seat ring to prevent live steam loss.

NOVA NFT250 SERIES

VARIABLE ORIFICE STEAM TRAPS

SPECIFICATION

Steam trap shall be of float and thermostatic design. Float shall be free of levers, linkages, or other mechanical connections. Float shall be weighted to maintain orientation and shall act as the valve being free to modulate condensate through the seat ring. Air vent shall be of balanced pressure design with stainless steel welded encapsulated bellows capable of discharging air and noncondensable gases continuously within 15°F of saturated temperature. Trap shall contain integral strainer and stainless steel exhaust port sleeve. Trap shall be cast iron bodied suitable for pressures to 250 psi and available in 1/2" through 2" NPT or flanged.

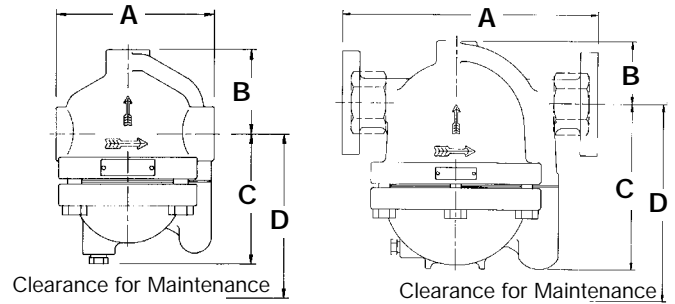

Connections:
 1/2"-2" NPT or 1 1/2"-2" Flanged

MATERIALS OF CONSTRUCTION

Body and CoverCast Iron ASTM A126B
 All Internal PartsStainless Steel
 Air VentBalanced Pressure, Stainless Steel
 Cover GasketGraphite Fiber

MAXIMUM OPERATING CONDITIONS

PMO: Max. Operating Pressure

ORIFICE	PMO	
20	20 psig	(1.4 barg)
50	50 psig	(3.5 barg)
100	100 psig	(6.9 barg)
150	150 psig	(10.3 barg)
250	250 psig	(17.2 barg)

PMA: Max. Allowable Pressure:
 250 psig (17.2 barg)

TMA: Max. Allowable Temperature:
 450°F (232°C)

Dimensions								
Model	Size	Connection	Inches (mm)				Weight Lbs. (kg)	
			A	B	C	D		
NFT250	1/2 & 3/4	NPT	4 1/4 (108)	2 3/4 (69)	3 5/8 (92)	5 1/2 (140)	6 (2.7)	
NFT251	3/4 & 1	NPT	5 1/2 (140)	2 15/16 (74)	4 9/16 (116)	6 3/4 (171)	13 (5.9)	
NFT252 [†]	1 & 1 1/2	NPT	11 (279)	2 15/16 (74)	7 3/4 (197)	10 (254)	41 (18.6)	
NFT253	1 1/2 & 2	NPT	13 3/4 (349)	2 15/16 (74)	11 5/8 (295)	15 3/8 (391)	120 (54.5)	
		250# Flg.	15 3/4 (400)	2 15/16 (74)	11 5/8 (295)	15 3/8 (391)	130 (59.1)	

Maximum Capacity—lbs/hr (10°F Below Saturation)																	
Trap	Orifice Size	Max. ΔP	Differential – PSIG (barg)														
			1 (.07)	5 (.34)	10 (.69)	15 (1.03)	20 (1.38)	30 (2.07)	50 (3.45)	75 (5.17)	100 (6.90)	125 (8.62)	150 (10.3)	175 (12.1)	200 (13.8)	225 (15.5)	250 (17.2)
NFT250	0.193	20	264	810	1050	1100	1200										
	0.141	50	190	430	610	750	870	1070	1400								
	0.102	100	88	160	250	300	350	425	530	670	710						
	0.091	150	70	140	219	260	295	345	410	470	520	555	590				
	0.067	250	37	90	140	170	200	240	300	340	390	405	415	440	460	480	500
NFT251	0.277	20	590	1600	2100	2400	2450										
	0.209	50	340	760	1080	1330	1540	1900	2460								
	0.157	100	200	500	650	740	830	950	1100	1300	1400						
	0.141	150	170	385	527	627	705	825	990	1130	1240	1330	1415				
NFT252	0.593	20	2720	6280	8600	10500	11700										
	0.469	50	1750	3920	5560	6830	7900	9700	12600								
	0.339	100	930	2170	3130	3840	4460	4990	6020	7030	7960						
	0.316	150	850	1935	2650	3150	3540	4140	4970	5685	6230	6690	7100				
NFT253	0.261	250	670	1400	1900	2400	2540	3000	3500	4100	4200	4900	5100	5300	5500	5750	6000
	1.102	20	8000	15000	18000	19900	22800										
	0.875	50	5460	12600	15600	16900	18400	21000	25400								
	0.593	100	2800	6350	8700	10900	12800	13700	16600	18700	21000						
NFT253	0.578	150	2690	6120	8385	9970	11200	13100	15700	17980	19700	21150	22450				
	0.484	250	1600	3770	5300	6470	7560	8610	10400	12100	13600	14600	15500	16300	17100	17800	18400

For Kg/Hr Multiply by .454

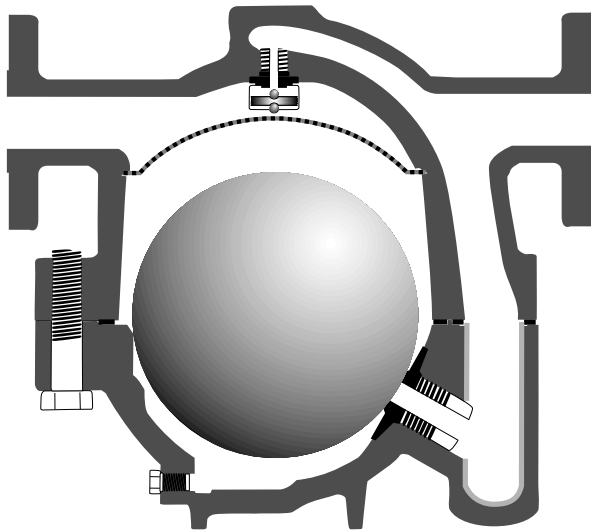

NOVA NFT650 SERIES VARIABLE ORIFICE STEAM TRAPS

Pressures To 650 PSIG (44.8 barg)
Temperatures to 750°F (400°C)

All Stainless Steel Internal Components — Hardened valves and seats. Extra long life and dependable service. Resists water hammer. Protects against erosion and corrosion.

Erosion Proof — Discharge passage is protected with a stainless steel liner.

Integral Strainer — Stainless Steel screen prevents dirt problems. Blow-down connection provided.

Thermostatic Air Vent — Provided with balanced pressure element for immediate and complete air venting.

Variable Orifice — Condensate is discharged continuously through the seat ring which is modulated by the float. This provides a smooth, even flow without high velocity or steam entrainment.

SLR Orifice — Optional continuous bleed prevents flash steam lockup when it is impossible to install trap at low point in system.

Guarantee — Traps are guaranteed against defects in materials or workmanship for 3 years.

APPLICATIONS

- Steam Lines
- Process Equipment
- Steam Cookers
- Steam Heated Vats
- Pressing Machinery
- Unit Heaters
- Oil Preheaters
- Converters
- Coils
- Rotating Drum

OPTIONS *See page 9*

- SLR - SLR Orifice
- B - Blowdown Valve (contact factory)
- Continuous Bleed Air Vent
- 300# or 600# Flanged Connection* (Raised Face)

*Available on NFT652 and NFT653 only.

Canadian Registration # OE0591.9C

MODELS

- **NFT651**—Low capacity
- **NFT652**—Medium capacity
- **NFT653**—High capacity

Installation Tip: Always install STV Test & Block Valve as part of trap station
SEE PAGE 118

Installation Tip: Add Uniflex Pipe Coupling for ease of maintenance
SEE PAGE 102

OPERATION

On startup, the thermostatic air vent (caged stainless welded bellows) is open, allowing air to flow freely through the vent valve orifice. When condensate flows into the trap, the float rises, allowing condensate to be discharged. Once air and non-condensibles have been evacuated, hot condensate will cause the thermostatic vent to close. Condensate will continue to be discharged as long as condensation occurs.

During normal operation, an increase in the load causes the liquid level in the trap to rise. The float then rises and rolls off the seat ring, allowing more condensate to flow out. The float sinks as the condensate load decreases, moving nearer to the seat ring, decreasing the effective size of the orifice and allowing less condensate to discharge. This provides smooth, continuous operation that reacts instantly to load variation while maintaining a water seal over the seat ring to prevent live steam loss.

FTN SERIES FLOAT & THERMOSTATIC STEAM TRAPS

Pressures To 125 PSIG (8.6 barg)
Temperatures to 450°F (232°C)

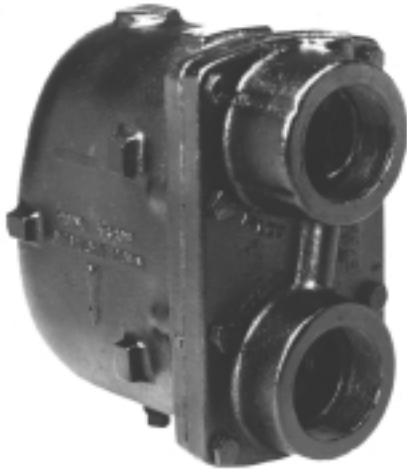

Universal Four-port Design — Four possible hookup combinations of the “H” pattern body and piping dimensions similar to other major manufacturers allow maximum installation flexibility for easy replacement of other traps. Inlet and outlet taps on larger sized traps located in the cover to permit larger capacities.

All Stainless Steel Internal Components — Hardened valves and seats. Extra long life and dependable service. Resists water hammer. Protects against erosion and corrosion.

Balanced Pressure Thermostatic Element — allows venting of non-condensibles while operating at design pressure.

Rugged Welded Stainless Steel Element — Increases service life.

Wide Selection of Differential Pressures — Sizes 3/4" to 2" available with 15, 30, 75 and 125 psig differential pressures.

Air Line Water Removal — Special configuration FTNA optimized for compressed air service.

Repairable In-line — Can be serviced without disturbing system piping.

MODELS

- **FTN-15**—Steam pressures to 15 PSIG
- **FTN-30**—Steam pressures to 30 PSIG
- **FTN-75**—Steam pressures to 75 PSIG
- **FTN-125**—Steam pressures to 125 PSIG
- **FTNA-75**—Air pressures to 75 PSIG
- **FTNA-125**—Air pressures to 125 PSIG

APPLICATIONS

- Unit Heaters & other Space Heating Equipment
- Heat Exchangers/Reboilers
- Steam Heating Coils
- Steam Main Drips
- Air Compressor Receivers
- Air Line Drips
- Air Powered Process Equipment

OPTIONS *See page 9*

- Repair Kits

Installation Tip: Always install STV Test & Block Valve as part of trap station
SEE PAGE 118

Installation Tip: Add Uniflex Pipe Coupling for ease of maintenance
SEE PAGE 102

OPERATION

Air entering trap is immediately discharged through the high capacity integral air vent. The thermostatic vent will close just prior to saturation temperature. The balanced design will allow venting of non-condensibles that collect in the float chamber when operating at design pressure. When steam enters the trap, the thermostatic air vent

closes to prevent steam loss. When steam gives up its latent heat, it becomes condensate. This “condensate” enters the trap and causes the stainless steel ball float to rise. Raising of the float opens the discharge valve, allowing condensate to be continuously discharged as it enters the trap. The condensate level in the trap body is maintained above the discharge seat, providing a positive seal against the loss of steam.

FTN SERIES FLOAT & THERMOSTATIC STEAM TRAPS

SPECIFICATION

Steam trap shall be of float and thermostatic design. Float shall actuate the valve via a hinged lever and linkage. Air vent shall be of balanced pressure design with stainless steel welded encapsulated bellows capable of discharging air and noncondensable gases continuously within 15°F of saturated temperature. Traps through 1-1/4" shall employ "H" pattern connections to accommodate multiple piping configurations. Trap shall be cast iron bodied suitable for pressures to 125 psi and available in 3/4" through 2" NPT.

3/4", 1" - All
1 1/4" - FTN-15,
FTN-30

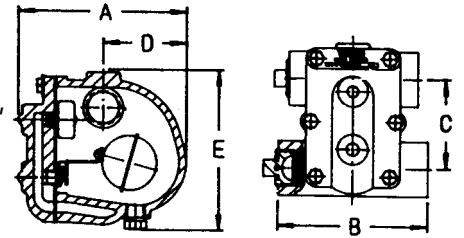

1 1/2", 2" - All *
1 1/4" - FTN-75,
FTNA-75*,
FTNA-125*

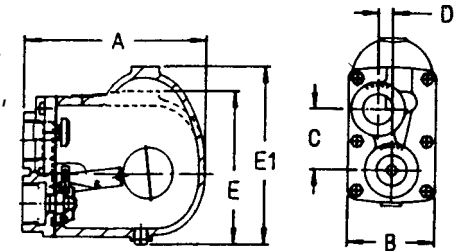

*1/8" NPT tap at top boss for balancing line.

MAXIMUM OPERATING CONDITIONS

PMO: Max. Operating Pressure

ORIFICE	PMO
15	15 psig (1.03 barg)
30	30 psig (2.07 barg)
75	75 psig (5.17 barg)
125	125 psig (8.62 barg)

PMA: Max. Allowable Pressure

250 psig (17.2 barg)

TMA: Max. Allowable Temperature

450°F (232°C)

Connections: 3/4"-2" NPT

MATERIALS OF CONSTRUCTION

Body & Cover . . . Cast Iron ASTM A126B

All Internal Stainless Steel

Air Vent (FTN only) Balanced Pressure,
Welded Stainless Steel

Dimensions		Inches (mm)						Weight lbs (kg)
Model No.	Size	A	B	C	D	E	E1	
FTN-15, FTN-30	3/4"	6.25 (159)	5.50 (140)	3.31 (84)	3.00 (76)	5.75 (146)	—	9 (4.1)
	1"	6.25 (159)	5.50 (140)	3.31 (84)	3.00 (76)	5.75 (146)	—	9 (4.1)
	1 1/4"	6.25 (159)	5.75 (146)	3.00 (76)	3.81 (97)	5.75 (146)	—	9 1/2 (4.3)
	1 1/2"	8.50 (216)	4.25 (108)	3.00 (76)	0.70 (18)	—	8.40 (213)	18 (8.2)
	2"	9.81 (249)	4.94 (123)	4.94 (123)	0.12 (3)	9.12 (232)	—	26 (11.8)
FTN-75, FTN-125 FTNA-75, FTNA-125	3/4"	6.25 (159)	5.50 (140)	3.31 (84)	3.00 (76)	5.75 (146)	—	9 (4.1)
	1"	6.25 (159)	5.50 (140)	3.31 (84)	3.00 (76)	5.75 (146)	—	9 (4.1)
	1 1/4"	8.50 (216)	4.25 (108)	3.00 (76)	0.70 (18)	—	8.40 (213)	18 (8.2)
	1 1/2"	8.50 (216)	4.25 (108)	3.00 (76)	0.70 (18)	—	8.40 (213)	18 (8.2)
	2"	9.81 (249)	4.94 (123)	4.94 (123)	0.12 (3)	9.12 (232)	—	26 (11.8)

Maximum Capacity—lbs/hr (10°F Below Saturation)																	
Trap	Size NPT	Orifice (in.)	Differential-PSIG (barg)														
			1/4 (.017)	1/2 (.034)	1 (.069)	2 (.138)	5 (.345)	10 (.690)	15 (1.03)	20 (1.38)	25 (1.72)	30 (2.07)	40 (2.76)	50 (3.45)	75 (5.17)	100 (6.90)	125 (8.62)
FTN-15	3/4"	.218	279	369	489	650	785	1000	1075								
FTN-15	1"	.218	279	369	489	650	785	1000	1075								
FTN-15	1 1/4"	.312	600	770	980	1240	1640	2000	2340								
FTN-15	1 1/2"	.500	1100	1700	2400	3300	5000	6600	7600								
FTN-15	2"	.625	2300	2800	3600	4650	6900	9000	10900								
FTN-30	3/4"	.218	279	369	489	650	785	1000	1075	1210	1300	1370					
FTN-30	1"	.218	279	369	489	650	785	1000	1075	1210	1300	1370					
FTN-30	1 1/4"	.228	375	500	690	910	1200	1500	1680	1800	1900	2000					
FTN-30	1 1/2"	.390	1000	1300	1700	2300	3400	4600	5500	6000	6600	7000					
FTN-30	2"	.500	1300	1800	2500	3400	5200	6800	7800	8600	9300	10000					
FTN-75 [†]	3/4"	.166	160	213	280	365	520	700	795	875	930	970	1120	1230	1450		
FTN-75 [†]	1"	.166	160	213	280	365	520	700	795	875	930	970	1120	1230	1450		
FTN-75 [†]	1 1/4"	.312	550	725	960	1300	1900	2650	3050	3400	3700	4000	4400	4750	5400		
FTN-75 [†]	1 1/2"	.312	550	725	960	1300	1900	2650	3050	3400	3700	4000	4400	4750	5400		
FTN-75 [†]	2"	.421	850	1100	1500	2000	3100	4150	4750	5200	5500	5800	6400	6800	7700		
FTN-125 [†]	3/4"	.125	100	135	175	230	330	415	500	585	620	685	750	830	970	1110	1190
FTN-125 [†]	1"	.125	100	135	175	230	330	415	500	585	620	685	750	830	970	1110	1190
FTN-125 [†]	1 1/4"	.246	400	520	680	890	1300	1700	2050	2300	2500	2700	3000	3200	3800	4200	4500
FTN-125 [†]	1 1/2"	.246	400	520	680	890	1300	1700	2050	2300	2500	2700	3000	3200	3800	4200	4500
FTN-125 [†]	2"	.332	550	675	880	1225	1950	2600	3000	3250	3500	3800	4200	4600	5500	6100	6600

For Kg/Hr Multiply by .454 †For FTNA capacities, multiply by 1.33.



MAX-FLO

SUPER HIGH CAPACITY FLOAT & THERMOSTATIC STEAM TRAPS

Pressures to 175 PSIG (12.1 barg)
Temperatures to 377°F (192°C)

- High Capacities
- Rugged cast iron body and cover
- Stainless steel thermostatic element eliminates air binding
- Stainless steel float and lever mechanism
- Below condensate level seat design prevents steam leakage
- Resistant to water hammer and corrosion
- In-Line repairable

APPLICATIONS

- Very High Condensate Loads
- Continuous Drainage With High Air Venting Capacity Requirements
- Industrial And Commercial Applications
- Absorption Systems
- Air Handling Coils
- Heat Exchangers
- Dryers Evaporators
- Hot water Generators
- Rendering Machines
- Steam Process Equipment
- Air Make-up Coils
- Unit Heaters And Cooking Kettles

MODELS

- HC-15 - Steam pressures to 15 PSIG
- HC-30 - Steam pressures to 30 PSIG
- HC-75 - Steam pressures to 75 PSIG
- HC-125 - Steam pressures to 125 PSIG
- HC-175 - Steam pressures to 175 PSIG

Installation Tip: Always install STV Test & Block Valve as part of trap station
SEE PAGE 118

Installation Tip: Add Uniflex Pipe Coupling for ease of maintenance
SEE PAGE 102

OPERATION

During startup, air and non-condensable gases enter the trap and are automatically vented through an accurate balanced pressure internal thermostatic air vent. As condensate enters the trap, the float and lever mechanism is raised, lifting the valve off

the seat, discharging the condensate. Condensate will continue to be discharged at the same rate at which it is entering. Any air or non-condensable gas that may accumulate will be continually and efficiently passed by the thermostatic air vent.

MAX-FLO

SUPER HIGH CAPACITY FLOAT & THERMOSTATIC STEAM TRAPS

SPECIFICATION

Steam trap shall be of float and thermostatic design. Float shall actuate the valve via a hinged lever and linkage. Air vent shall be of balanced pressure design with stainless steel welded encapsulated bellows capable of discharging air and noncondensable gases continuously. Trap shall be cast iron bodied suitable for pressures to 175 PSI and shall be a _____ NPT connection.

MAXIMUM OPERATING CONDITIONS

PMO: Max. Operating Pressure see orifice selection
 TMO: Max. Operating Temperature saturated at pressure
 PMA: Max. Allowable Pressure 175 PSIG (12.1 barg)
 PMA: Max. Allowable Pressure 377°F (192°C)

MATERIALS OF CONSTRUCTION

Body & CoverCast Iron 30,000 psi tensile
 Valve Pin and SeatStainless Steel (Hardened)
 FloatStainless Steel
 Lever AssemblyStainless Steel
 Thermostatic Air VentStainless Steel Cage & Thermal Element
 Cover BoltsGrade 5
 BaffleStainless Steel (2-1/2' (65mm) units only)

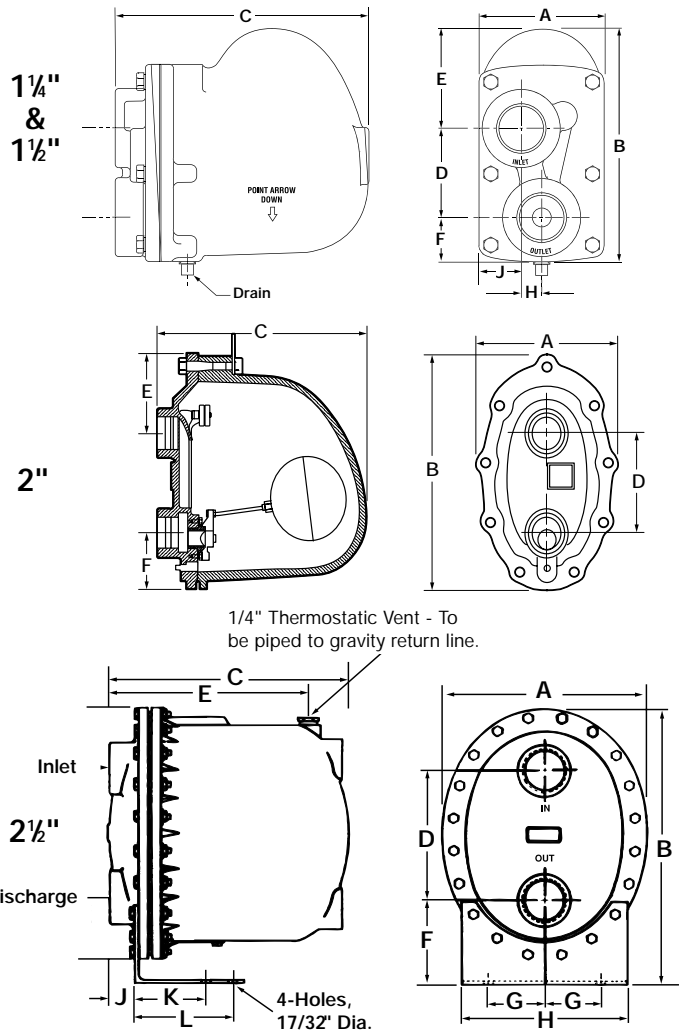

Dimensions														Weight lbs (kg)
MODEL	NPT Size in. (mm)	A	B	C	D	E	F	G	H	J	K	L		
HC-175	1 1/4 & 1 1/2 (32 & 40)	4 1/2 (108)	8 5/8 (211)	8 3/8 (217)	3 (76)	3 3/8 (86)	2 (51)	—	4 5/8 (17.8)	1 3/8 (35)	—	—	18 (8)	
ALL	2 (50)	10 (254)	15 (381)	15 1/2 (394)	6 3/8 (168)	4 3/4 (121)	3 1/2 (89)	—	—	—	—	—	108 (49)	
ALL	2 1/2 (65)	14 1/2 (368)	20 3/4 (514)	17 3/8 (441)	9 1/2 (241)	14 1 5/8 (379)	6 1/4 (159)	5 (127)	12 (305)	1 3/8 (41)	4 1/2 (114)	7 (178)	175 (79)	

Maximum Capacity-lbs/hr																			
Trap	Orifice Max ΔP	Differential - PSIG (barg)																	
		1/4 (0.017)	1/2 (0.035)	1 (0.07)	2 (0.14)	5 (0.35)	10 (0.69)	15 (1.0)	20 (1.4)	25 (1.69)	30 (2.1)	40 (2.8)	50 (3.5)	60 (4.2)	75 (5.2)	100 (6.9)	125 (8.6)	150 (10.4)	175 (12.1)
HC-15, 2"	.970	6500	8000	9500	10800	15500	20900	24000											
HC-15, 2 1/2"	1.875	17000	20000	27000	36000	46000	55000	60000											
HC-30, 2"	.876	3400	4600	6400	8400	12500	16900	19000	21500	23590	24000								
HC-30, 2 1/2"	1.624	14000	17000	20900	25500	33200	40500	45500	49400	52700	55600								
HC-75, 2"	.858	2550	3150	4300	5450	7600	10400	11400	12500	13500	14250	15600	17150	18600	20500				
HC-75, 2 1/2"	1.031	5900	7700	10000	13000	18600	24200	28300	31600	34400	36800	41100	44800	48040	52300				
HC-125, 2"	.448	2300	2800	3450	4200	5450	6600	7450	8050	8600	8950	10350	11950	13400	15600	18850	21800		
HC-125, 2 1/2"	.797	4000	5300	6900	9100	13000	17100	20000	22400	24500	26300	29400	32100	34650	37600	42100	46000		
HC-175, 1 1/4"	.210	260	350	480	640	940	1190	1450	1560	1670	1750	1910	2040	2100	2300	2500	2900	3140	3240
HC-175, 1 1/2"	.210	260	350	480	640	940	119	1450	1560	1670	1750	1910	2040	2100	2300	2500	2900	3140	3240
HC-175, 2"	.375	2100	2600	3000	3500	4400	4900	5350	5800	6250	6700	7600	8600	9550	11000	13000	14750	16500	18000
HC-175, 2 1/2"	.688	2460	3350	4600	6200	9400	12800	15400	17500	19300	21000	23800	26300	28060	31600	35900	39700	43100	46200

For Kg/Hr Multiply by .454



FTE 10



FTE 14



FTE 43



FTE 44

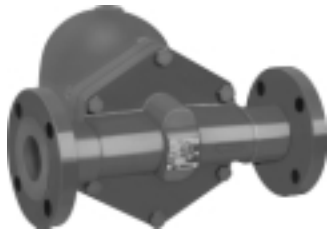

FTE 44F

APPLICATIONS

- Very High Condensate Loads
- Continuous Drainage With High Air Venting Capacity Requirements
- Industrial And Commercial Applications
- Absorption Systems
- Air Handling Coils
- Heat Exchangers
- Dryers Evaporators
- Hot water Generators
- Rendering Machines
- Steam Process Equipment
- Air Make-up Coils
- Unit Heaters And Cooking Kettles

OPTIONS

- BSPT Threaded connection
- S-SLR Orifice on FTE-10
- Socket Weld connection on FTE-44
- Flanged connections
 - ANSI 125/150, 300, 600
 - DIN 10, 16, 25 or 40
 - BS10 - F, H, J, K or R

OPERATION

During startup, air and non-condensable gases enter the trap and are automatically vented through an accurate balanced pressure internal thermostatic air vent. As condensate enters the trap, the float and lever mechanism is raised,

lifting the valve off the seat, discharging the condensate. Condensate will continue to be discharged at the same rate at which it is entering. Any air or non-condensable gas that may accumulate will be continually and efficiently passed by the thermostatic air vent.

FTE SERIES FLOAT & THERMOSTATIC STEAM TRAPS

Pressures to 464 PSIG (32 barg)
Temperatures to 850°F (454°C)

- High Capacities
- Rugged cast iron, ductile iron or cast steel body and cover
- Stainless steel thermostatic element eliminates air binding
- Stainless steel float and lever mechanism
- Below condensate level seat design prevents steam leakage
- Resistant to water hammer and corrosion
- In-Line repairable

MODELS

CAST IRON BODY

- FTE-10 – To 200 PSIG Threaded Connections
- FTE-43 – To 200 PSIG Flanged Connections

DUCTILE IRON BODY

- FTE-14 – To 200 PSIG Threaded Connections

CAST STEEL BODY

- FTE-44 – To 465 PSIG Threaded/Socket Weld Connections
- FTE-44F – To 465 PSIG Flanged Connections

Installation Tip: Always install STV Test & Block Valve as part of trap station
SEE PAGE 118

Installation Tip:
Add Uniflex Pipe Coupling for ease of maintenance on NPT Traps
SEE PAGE 102

SERIES FTE DIMENSIONS

DIMENSIONS inches (mm) AND WEIGHTS pounds (kg) SERIES FTE-10 & FTE 44

Size	Inches (mm)						Weight Lbs(kg)	
	A	B	C	D	E	F	FTE-10	FTE-44
1/2	5 ¹ / ₆ (128)	2 ¹ / ₆ (54)	2 ¹ / ₆ (54)	5 ¹ / ₆ (145)	4 ¹ / ₆ (110)	6 ¹ / ₆ (170)	10.5 (4.8)	11.4 (5.2)
3/4	5 ¹ / ₆ (128)	2 ¹ / ₆ (54)	2 ¹ / ₆ (54)	5 ¹ / ₆ (145)	4 ¹ / ₆ (110)	6 ¹ / ₆ (170)	10.5 (4.8)	11 (5.0)
1	5 ¹ / ₆ (128)	4 ¹ / ₆ (110)	2 ¹ / ₆ (75)	7 ¹ / ₂ (190)	6 ¹ / ₆ (160)	8 ¹ / ₂ (216)	18.7 (8.5)	17.6 (8.0)
1 ¹ / ₂	11 ¹ / ₆ (282)	5 (127)	4 ¹ / ₆ (110)	10 (254)	7 ¹ / ₆ (200)	11 ¹ / ₆ (289)	49.5 (22.5)	48.4 (22.0)
2	12 ¹ / ₆ (308)	5 ¹ / ₂ (140)	5 (127)	10 ¹ / ₄ (260)	7 ¹ / ₆ (200)	11 ¹ / ₆ (300)	61.6 (28.0)	59.4 (27.0)

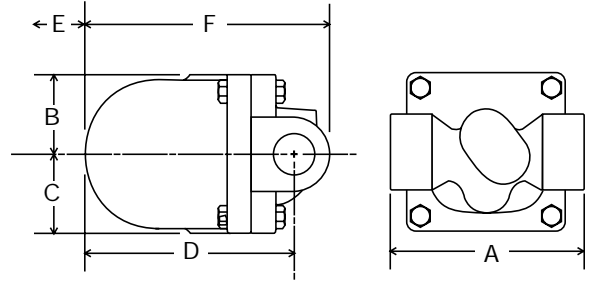

FTE-10 CAST IRON & FTE-44 CAST STEEL 1/2" & 3/4"

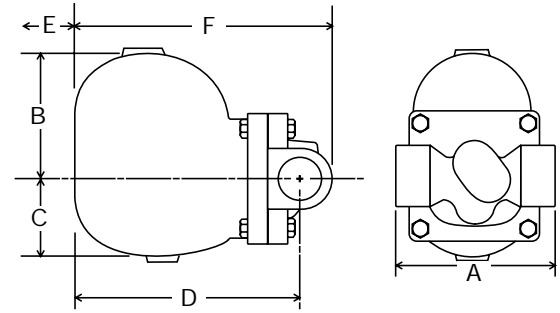

FTE-10 CAST IRON & FTE-44 CAST STEEL 1"

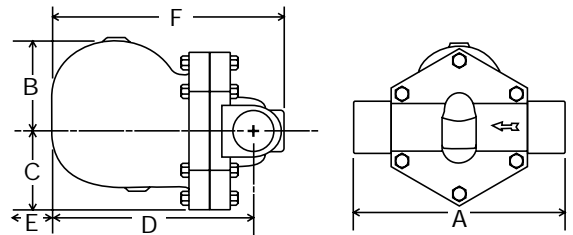

FTE-10 CAST IRON & FTE-44 CAST STEEL 1 1/2" & 2"

DIMENSIONS inches (mm) AND WEIGHTS pounds (kg) SERIES FTE-14

Size	Inches (mm)				Weight lbs. (kg)
	A	B	C	D	
1/2	4 ³ / ₄ (121)	4 ¹ / ₄ (108)	2 ⁵ / ₆ (67)	5 ¹ / ₆ (148)	7.9 (3.6)
3/4	4 ³ / ₄ (121)	4 ¹ / ₄ (108)	2 ⁵ / ₆ (67)	5 ¹ / ₆ (148)	7.9 (3.6)
1	5 ¹ / ₆ (145)	4 ¹ / ₄ (108)	3 (76)	6 ¹ / ₆ (167)	10.1 (4.6)

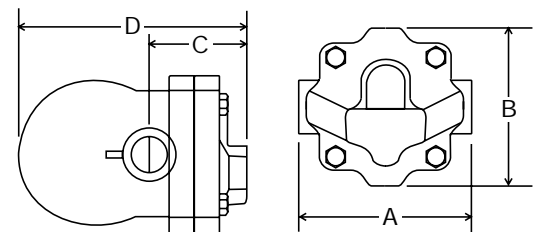

FTE-14-DUCTILE IRON 1/2", 3/4" & 1"

SERIES FTE DIMENSIONS

DIMENSIONS inches (mm)
AND WEIGHTS pounds (kg)
SERIES FTE-43

Size	Inches (mm)					Weight Lbs. (kg)
	A	B	C	D	E	
1/2	5 ⁵ / ₁₆ (150)	2 ¹ / ₈ (54)	2 ¹ / ₈ (54)	7 ¹ / ₂ (190)	4 ⁵ / ₁₆ (110)	15.4 (7.0)
3/4	5 ⁵ / ₁₆ (150)	2 ¹ / ₈ (54)	2 ¹ / ₈ (54)	7 ⁷ / ₁₆ (192)	4 ⁵ / ₁₆ (110)	16.5 (7.5)
1	6 ⁵ / ₁₆ (160)	4 ⁵ / ₁₆ (110)	2 ¹⁵ / ₁₆ (75)	9 ⁹ / ₁₆ (245)	6 ⁵ / ₁₆ (160)	25.3 (11.5)
1 ¹ / ₂	9 ⁵ / ₁₆ (230)	5 (127)	4 ⁵ / ₁₆ (110)	13 ³ / ₈ (333)	7 ⁷ / ₈ (200)	61.6 (28.0)
2	9 ⁵ / ₁₆ (230)	5 ¹ / ₂ (140)	5 (127)	13 ¹ / ₂ (343)	7 ⁷ / ₈ (200)	74.8 (34.0)

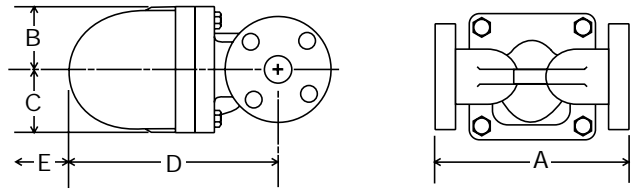

FTE-43 CAST IRON 1/2" & 3/4"

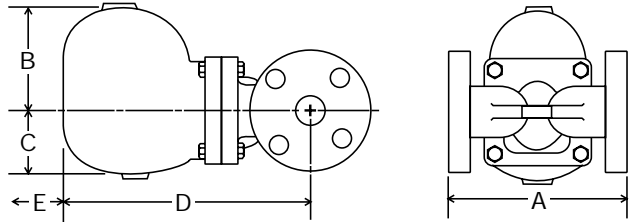

FTE-43 CAST IRON 1"

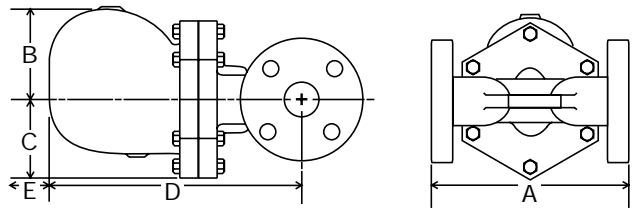

FTE-43 CAST IRON 1¹/₂" & 2"

DIMENSIONS inches (mm)
AND WEIGHTS pounds (kg)
SERIES FTE-44F

Size	Inches (mm)					Weight Lbs. (kg)
	A	B	C	D	E	
1/2	8 ¹ / ₄ (210)	2 ¹ / ₈ (54)	2 ¹ / ₈ (54)	5 ⁵ / ₁₆ (141)	4 ⁵ / ₁₆ (110)	16.5 (7.5)
3/4	8 ¹ / ₄ (210)	2 ¹ / ₈ (54)	2 ¹ / ₈ (54)	5 ⁵ / ₁₆ (141)	4 ⁵ / ₁₆ (110)	17.6 (8.0)
1	8 ¹ / ₄ (210)	4 ⁵ / ₁₆ (110)	2 ¹⁵ / ₁₆ (75)	7 ¹ / ₂ (190)	6 ⁵ / ₁₆ (160)	25.3 (11.5)
1 ¹ / ₂	12 ³ / ₁₆ (325)	5 (127)	4 ⁵ / ₁₆ (110)	9 ⁵ / ₁₆ (245)	7 ⁷ / ₈ (200)	60.5 (27.5)
2	12 ³ / ₁₆ (325)	5 ¹ / ₂ (140)	5 (127)	9 ⁵ / ₁₆ (251)	7 ⁷ / ₈ (200)	74.8 (34.0)

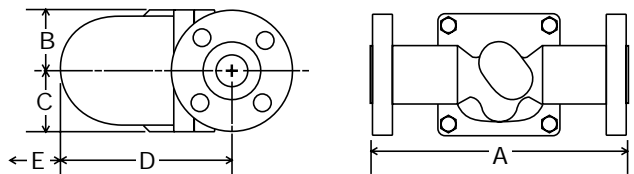

FTE-44F CAST STEEL 1/2" & 3/4"

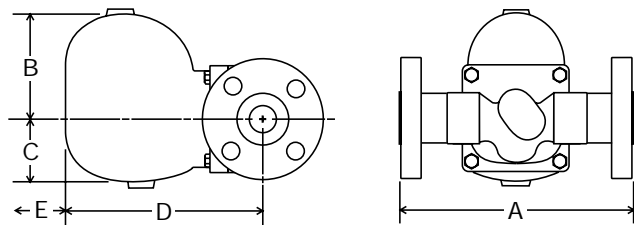

FTE-44F CAST STEEL 1"

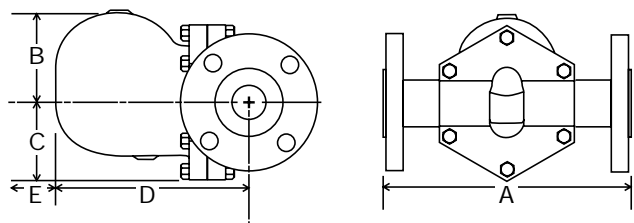

FTE-44F CAST STEEL 1¹/₂" & 2"



DURA-FLO INVERTED BUCKET STEAM TRAPS

Pressures To 250 PSIG (17.2 barg)
Temperatures to 450°F (232°C)

Hardened Stainless Steel Valve and Seat — Long life and maximum corrosion resistance.

Stainless Steel Bucket — Long lasting, rugged and naturally resistant to water hammer.

Inexpensive — Low maintenance and initial cost.

Repairable in-line — All working parts lift out of top of trap.

Cast Iron Body — Durable heavy wall construction provides years of reliable service.

Suitable for Wide Variety of Loads/Applications — Horizontal and vertical models in thirteen body sizes.

Resists Dirt and Scale — Valve and seats positioned at top of traps and internal stainless strainer available on most horizontal models ensure long service.

APPLICATIONS

- Steam Lines
- Process Equipment
- Steam Cookers
- Steam Heated Vats
- Pressing Machinery
- Unit Heaters
- Oil Preheaters
- Converters
- Coils
- Rotating Drum

OPTIONS *See page 9*

- Repair Kits

Canadian Registration # OE 0591.1C

Installation Tip: Always install STV Test & Block Valve as part of trap station SEE PAGE 118

Installation Tip: Add Uniflex Pipe Coupling for ease of maintenance SEE PAGE 102

MODELS

- 80S—Low capacity horizontal w/integral strainer
- 81S—Medium low capacity horizontal w/integral strainer
- 82S—Medium capacity horizontal w/integral strainer
- 83S—Medium high capacity horizontal w/integral strainer
- 84—High capacity horizontal
- 85—Super high capacity horizontal
- 86—Ultra high capacity horizontal
- 21—Medium low capacity vertical
- 22—Medium capacity vertical
- 23—Medium high capacity vertical
- 24—High capacity vertical
- 25—Super high capacity vertical
- 26—Ultra high capacity vertical

OPERATION

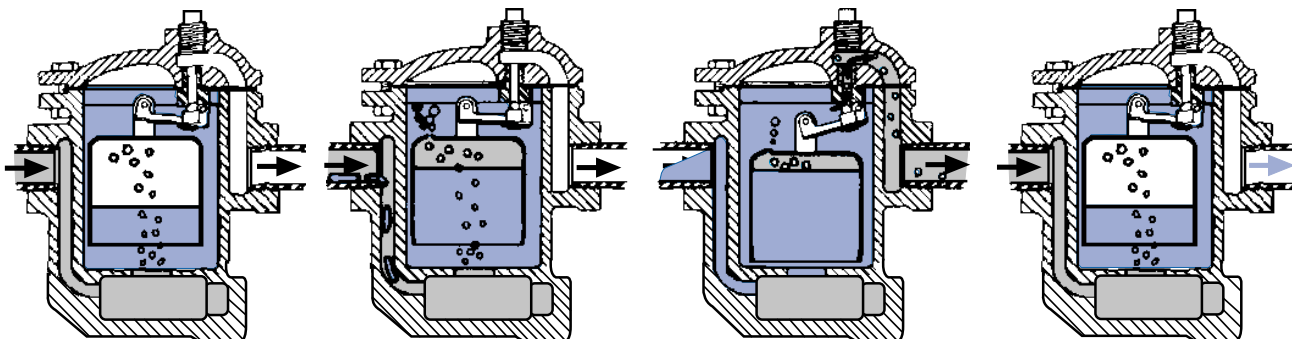

Trap Closed – After trap is installed and primed, steam entering the trap collects in the top of the bucket, floating the bucket and forcing the valve into its seat.

Trap Begins to Open – As condensate begins to flow into the trap, steam and air are forced from the bucket. This causes the bucket to begin losing buoyancy, tending to pull the valve from its seat.

Trap Discharges – When enough condensate has entered the trap, displacing the steam and air, the bucket drops, pulling the valve from the seat and allowing condensate and air to discharge.

Trap Closes – As the flow of condensate stops, steam enters the trap and refloats the bucket, forcing the valve into its seat. The cycle then repeats as more condensate reaches the trap.

DURA-FLO INVERTED BUCKET STEAM TRAPS

SPECIFICATION

Furnish and install as shown on the plans, inverted bucket traps capable of discharging condensate, air and other non-condensable gases without loss of steam. These traps shall have a heavy cast iron body, hardened stainless steel valve and seat, all stainless steel linkage and bucket, and an asbestos free fiber cover gasket.

MAXIMUM OPERATING CONDITIONS

PMO: Max. Operating Pressure see orifice selection
 TMO: Max. Operating Temperature saturated at pressure
 PMA: Max. Allowable Pressure 250 psig (17.2 barg)
 TMA: Max. Allowable Temperature 450°F (232°C)

MATERIALS OF CONSTRUCTION

Body & CoverCast Iron ASTM-A-126/A48
 Bucket & LinkageStainless Steel
 Valve & SeatHardened Chrome Steel
 StandpipeSteel Pipe
 Cover GasketAsbestos Free Fiber

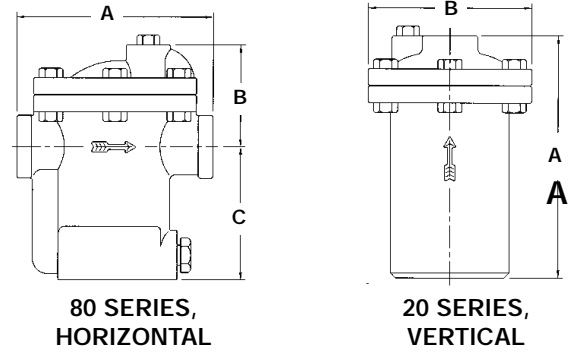

Connections: ½" - 2½" NPT

DURA-FLO Dimension Table					
Trap	End Connections	Inches (mm)			Weight Lbs (kg)
		A	B	C	
80S	½, ¾	5½ (129)	2⅞ (69)	3½ (89)	7 (3.2)
81S	½, ¾, 1	5½ (129)	2⅞ (69)	4⅞ (113)	8 (3.6)
82S	½, ¾	7 (178)	3⅞ (98)	5⅞ (138)	22 (10.0)
83S	¾, 1	8⅞ (206)	5 (127)	7⅞ (194)	32 (14.5)
84	1, 1¼	9 (229)	5⅞ (146)	7⅞ (199)	47 (21.3)
85	1½, 2	10¼ (260)	8 (203)	8⅞ (213)	74 (33.6)
86	2, 2½	13 (330)	9⅞ (248)	11 (279)	140 (63.5)
21	½	6⅞ (162)	4¼ (108)	—	6.5 (2.9)
22	½, ¾	8 (203)	5⅞ (143)	—	16 (7.3)
23	¾, 1	10½ (267)	6⅞ (175)	—	28 (12.7)
24	1, 1¼	12½ (318)	7⅞ (190)	—	35 (15.9)
25	1, 1½	14⅞ (365)	9⅞ (230)	—	60 (27.2)
26	1½, 2	16⅞ (424)	10¼ (260)	—	90 (40.8)

DURA-FLO CAPACITY TABLES

Trap	Orifice		0.50 (.034)	1 (.069)	5 (.345)	10 (.690)	15 (1.03)	20 (1.38)	25 (1.72)	30 (2.07)	40 (2.76)	60 (4.14)	70 (4.83)	80 (5.52)	100 (6.90)	125 (8.62)	130 (8.97)	150 (10.3)	180 (12.4)	200 (13.8)	225 (15.5)	250 (17.2)
	Size	Max ΔP																				
80S	3/16	20	200	270	450	560	640	690														
	1/8	80	80	110	200	300	360	420	460	500	540	620	660	690								
	7/64	125	-	55	90	145	195	260	305	345	400	485	525	565	640	680						
	3/32	150	-	-	70	110	150	200	240	270	310	380	410	440	480	540	545	570				
81S & 21	1/4	15	300	450	830	950	1060															
	3/16	30	190	300	540	670	770	880	950	1000												
	5/32	70	100	165	180	430	495	585	655	710	770	900	950									
	1/8	125	70	130	220	340	390	460	515	560	610	710	760	800	860	950						
	7/64	200	-	65	150	230	275	335	375	405	455	545	580	610	665	735	780	810	850	860		
3/32	250	-	-	100	150	190	240	270	290	340	420	450	470	520	575	585	620	670	700	730	760	
82S & 22	5/16	15	570	850	1600	1900	2100															
	1/4	30	350	500	950	1380	1630	1800	1900	2050												
	3/16	70	250	420	785	950	1120	1260	1395	1500	1700	2000	2200									
	5/32	125	180	300	560	680	800	900	995	1070	1220	1440	1550	1650	1800	2000						
	1/8	200	100	180	325	465	505	575	650	710	805	980	1050	1105	1225	1375	1410	1500	1560	1600		
7/64	250	75	130	240	340	370	420	480	520	590	720	770	810	900	1010	1020	1100	1170	1230	1280	1300	
83S & 23	1/2	15	1410	1880	2900	3500	3900															
	3/8	30	990	1400	2300	2700	3300	3500	3800	4000												
	5/16	60	600	940	1730	2045	2510	2825	2995	3135	3800	4400										
	9/32	80	510	735	1350	1595	1960	2205	2340	2450	2880	3490	3800	4000								
	1/4	125	385	600	1100	1300	1600	1800	1910	2000	2350	2850	3100	3300	3600	3900						
	7/32	180	300	490	860	1165	1350	1595	1865	2085	2205	2510	2695	2820	3065	3185	3300	3500	3700			
3/16	250	255	400	700	950	1100	1300	1520	1700	1800	2050	2200	2300	2500	2600	2700	2800	3020	3200	3400	3500	
84 & 24	5/8	15	2160	2900	4800	5800	6500															
	1/2	30	1450	2250	3700	4750	5200	6000	6500	6800												
	3/8	60	1050	1750	2950	3550	4000	4700	5000	5400	5800	6800										
	11/32	80	800	1560	2500	2900	3200	3500	4000	4400	4850	5750	6000	6400								
	5/16	125	660	1200	1950	2450	2750	3100	3250	3500	4000	4800	5250	5600	6200	6700						
	9/32	180	550	950	1500	1900	2200	2350	2700	2900	3250	3800	4250	4500	4800	5500	5600	5700	6000			
1/4	250	350	580	1000	1250	1450	1800	2000	2200	2600	3150	3350	3500	3800	4300	4450	4700	5000	5300	5500	5700	
85 & 25	3/4	15	3100	4160	7600	9000	10000															
	9/16	30	1800	2900	5200	6400	7700	8500	9200	9800												
	7/16	60	1400	2200	3800	5000	6000	6600	7100	7600	8300	9500										
	3/8	100	1100	1700	3000	3600	4500	5200	5800	6100	7000	8500	9200	9700	10400							
	11/32	130	900	1500	2600	3200	3900	4500	5000	5400	6200	7500	8050	8500	9600	10900	11000					
	5/16	180	750	1200	2100	2600	3200	3700	4100	4500	5400	6600	7000	7257	8118	8979	9040.5	9500	10000			
	9/32	225	600	970	1700	2100	2600	2950	3300	3600	4500	5400	5700	5900	6600	7300	7350	7850	8400	9200	9800	
1/4	250	400	700	1200	1500	1900	2100	2400	2600	3200	3800	4000	4150	4600	5100	5150	5500	5950	6350	6650	7000	
86 & 26	1-1/16	15	6240	8400	14500	17300	19200															
	7/8	25	4100	5490	10000	12930	15620	18500	20000													
	3/4	40	2900	4500	8200	10600	12800	15000	16700	18000	20000											
	5/8	60	2100	3500	6900	8700	10600	12100	13300	14250	16300	19800										
	9/16	80	1900	3095	6000	7600	9300	10600	11700	12500	14300	17300	18300	19000								
	1/2	125	1600	2600	5000	6400	7800	8900	9800	10500	12000	14500	15400	16300	18000	20000						
	7/16	180	1400	2210	4180	5530	6640	7500	8490	9230	10450	12420	13300	14150	15750	17400	17900	18500	20000			
	3/8	250	1000	1800	3400	4500	5400	6100	6900	7500	8500	10100	10800	11500	12800	14200	14300	15600	16900	17500	18500	19000

For Kg/Hr Multiply by .454

DURA-FLO INVERTED BUCKET STEAM TRAPS PCA REPAIR KITS

Quick, easy and economical
Simplifies and standardizes inventory
All stainless steel corrosion resistant internal parts
Hardened stainless steel condensate valves and seats
for extra long life

MODELS

- 80S—Orifice ratings 20, 80, 125, 150
- 81S & 21—Orifice ratings 15, 30, 70, 125, 200, 250
- 82S & 22—Orifice ratings 15, 30, 70, 125, 200, 250
- 83S & 23—Orifice ratings 15, 30, 60, 80, 125, 180, 250
- 84 & 24—Orifice ratings 15, 30, 60, 80, 125, 180, 250
- 85 & 25—Orifice ratings 15, 30, 60, 100, 130, 180, 225, 250
- 86 & 26—Orifice ratings 15, 25, 40, 60, 80, 125, 180, 250

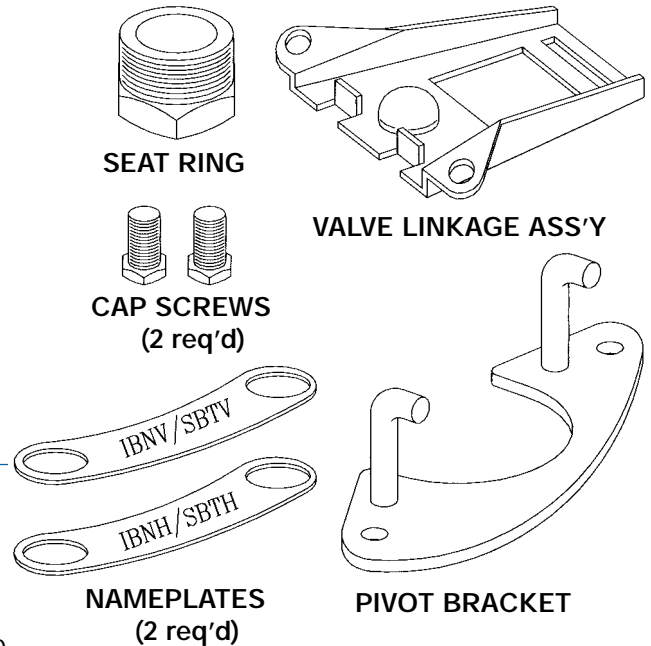

Supplied in a labeled, clear plastic bag.

FTN SERIES FLOAT & THERMOSTATIC STEAM TRAPS REPAIR KITS

High quality replacement kits
Rebuild existing F & T Traps far more economically than
replacement
Quick, easy and economical
Simplifies and standardizes inventory
All stainless steel corrosion resistant internal parts
Hardened stainless steel condensate valves and seats
for extra long life
Repairs other leading manufacturers' F & T Traps

MODELS

- FTN-15 available in ¾", 1", 1¼", 1½" and 2"
- FTN-30 available in ¾", 1", 1¼", 1½" and 2"
- FTN-75 available in ¾", 1", 1¼", 1½" and 2"
- FTN-125 available in ¾", 1", 1¼", 1½" and 2"

All ¾" and 1" kits as well as 1¼" FTN-15 and FTN-30 kits
supplied with cover assembly.

All 1¼" FTN-75 and FTN-125 kits as well as all 1½" and 2"
kits supplied as mechanism complete.

See Capacity Charts on page 37

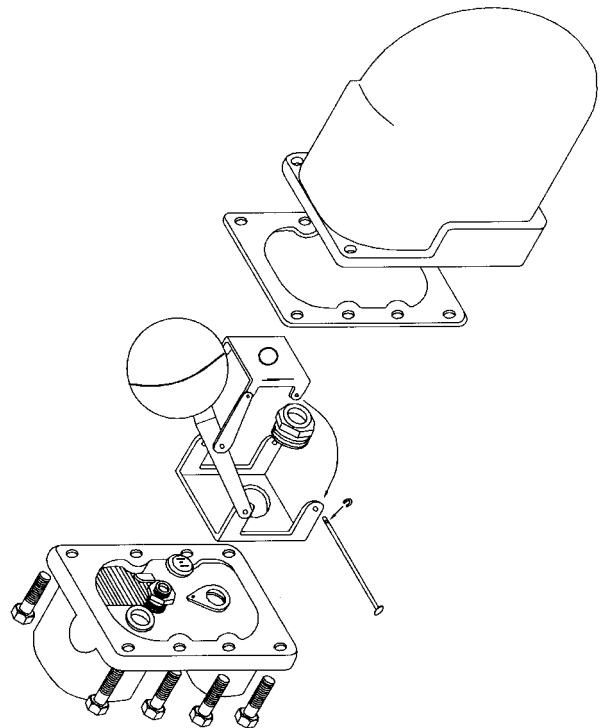

Consult factory for latest crossover fitments.



SEALED STAINLESS STEEL DURA-FLO INVERTED BUCKET STEAM TRAPS

Pressures to 650 PSIG (45 barg)
Temperatures to 497°F (258°C)

APPLICATIONS

- Steam Lines
- Process Equipment
- Steam Cookers
- Steam Heated Vats
- Pressing Machinery
- Unit Heaters
- Oil Preheaters
- Converters
- Coils
- Rotating Drum

Canadian Registration #: OE10389.52

For information on Big Block UMTVS-BB Connector
SEE PAGE 116

Easy Trap Replacement — Universal two bolt swivel mounting option simplifies removal from system.

Simple Installation — Stainless mounting Block mounts permanently into system. Trap installs via two bolt universal mount connection.

Hardened Chrome Steel Valve and Seat — Long life and maximum corrosion resistance.

Stainless Steel Bucket — Long lasting, rugged and naturally resistant to water hammer.

Inexpensive — Low maintenance and initial cost.

Stainless Steel Body — Durable heavy wall construction provides years of reliable service and resists corrosion and freezing.

Suitable for Wide Variety of Loads/Applications — Horizontal models in three body sizes.

Resists Dirt and Scale — Valve and seats positioned at top of traps ensure long service.

Maintenance Free (TSBT-S and USBT-S) — Sealed design prevents unnecessary tampering. Trap can be inspected and replaced without breaking pipe.

Freeze Resistant — Extruded SS Body helps prevent problems associated with freezing conditions.

MODELS

NPT CONNECTION

- **TSBT-LS** – Low Capacity, 200 PSIG
- **TSBT-MS** – Medium Capacity, 340 PSIG
- **TSBT-HS** – High Capacity, 650 PSIG

UMT CONNECTION

- **USBT-LS** – Low Capacity, 200 PSIG
- **USBT-MS** – Medium Capacity, 340 PSIG
- **USBT-HS** – High Capacity, 650 PSIG

UMT CONNECTOR BLOCKS

- **UMTC**–Standard connector (1/2" & 3/4" only)
- **UMTCY-RH**–Right Hand Connector with Y Strainer
- **UMTCY-LH**–Left Hand connector with Y Strainer
- **UMTVS-BB**–Connector with Isolation Valves, Strainer, Blowdown Valve and Test Port

OPERATION

After trap is installed and primed, steam entering the trap collects in the top of the bucket, floating the bucket and forcing the valve into its seat. As condensate begins to flow into the trap, steam and air are forced from the bucket. This causes the bucket to begin losing buoyancy, tending to pull the valve from its seat. When

enough condensate has entered the trap, displacing the steam and air, the bucket drops, pulling the valve from the seat and allowing condensate and air to discharge. As the flow of condensate stops, steam enters the trap and re-floats the bucket, forcing the valve into its seat. The cycle then repeats as more condensate reaches the trap.

SEALED STAINLESS STEEL DURA-FLO INVERTED BUCKET STEAM TRAPS

SPECIFICATION

Furnish and install as shown on the plans, inverted bucket traps capable of discharging condensate, air and other non-condensable gases without loss of steam. These traps shall have a stainless steel sealed body, hardened chrome steel valve and seat and an all stainless steel linkage and bucket. It shall have a universal mount connector option.

MAXIMUM OPERATING CONDITIONS

PMO: Max. Operating Pressure See Orifice Selection
 TMO: Max. Operating Temperature Saturated at PMO
 PMA: Max. Allowable Pressure -
 LS 200 psig (13.8 barg) at 450°F (232°C)
 MS 307 psig (21.2 barg) at 450°F (232°C)
 HS 650 psig (44.8 barg) at 497°F (258°C)
 TMA: Max. Allowable Temperature -
 MS, LS & HS - 800°F (425°C)

MATERIALS OF CONSTRUCTION

BodyAISI 304 SS
 BucketAISI 304 SS
 Bucket Clip.....AISI 304 SS
 LeverAISI 304 SS
 Inlet TubeAISI 304 SS
 Valve.....Hardened Chrome Steel AISI D3
 Valve SeatHardened Chrome Steel AISI D3
 ConnectorAISI 304 SS

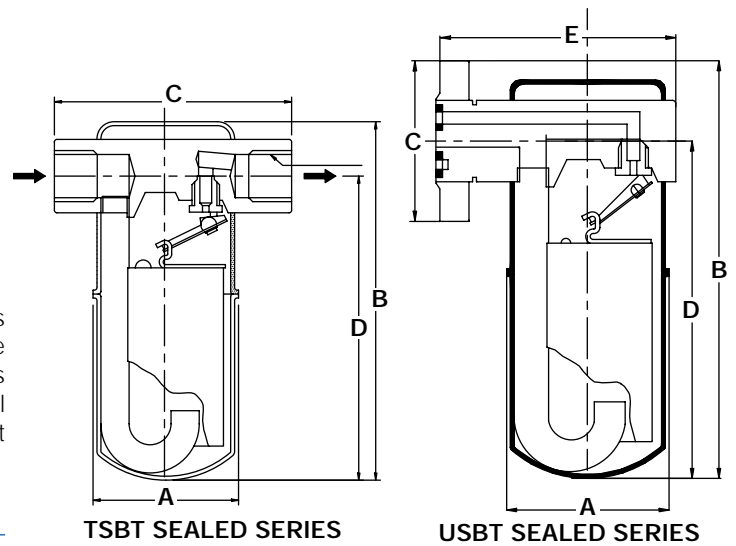

Connections: 3/8" - 1" NPT

DIMENSIONS inches (mm) AND WEIGHTS pounds (kg)

Model	Inches (mm)				Weight lbs(kg)
	A	B	C	D	
TSBT-LS	2 3/8 (70)	5 1/8 (142)	4 1/8 (110)	4 1/8 (116)	2.25 (1)
TSBT-MS	2 3/8 (70)	6 1/8 (167)	4 1/8 (110)	5 1/8 (141)	2.5 (1.1)
TSBT-HS	3 1/8 (99)	8 1/8 (218)	5 (127)	7 1/8 (187)	7 (3.2)

Connections:
Universal Mount Two Bolt Swivel Connection

DIMENSIONS inches (mm) AND WEIGHTS pounds (kg)

Model	Inches (mm)					Weight lbs(kg)
	A	B	C	D	E	
USBT-LS	2 3/8 (70)	6 (152)	2 3/8 (70)	4 1/8 (117)	4 (101.6)	4.25 (2)
USBT-MS	2 3/8 (70)	7 1/8 (183)	2 3/8 (70)	5 1/8 (148)	4 (101.6)	4.75 (2.2)
USBT-HS	3 1/8 (99)	8 3/8 (222)	2 3/8 (70)	7 1/8 (187)	5 (127)	7 (3.2)

Maximum Capacity—(lbs/hr)

Trap	Orifice		Differential Pressure												
			5	10	15	30	40	70	80	125	200	250	300	400	650
	Size	MOP	(0.34)	(0.69)	(1.03)	(2.07)	(2.76)	(4.83)	(5.52)	(8.62)	(13.79)	(17.24)	(20.69)	(27.59)	(44.83)
SBT-LS & TSBT-LS	3/32	200	85	120	145	200	230	300	325	400	500				
	1/4	15	800	920	1040										
USBT-MS & TSBT-MS	3/16	30	540	690	800	1000									
	5/32	70	390	490	560	700	790	940							
	1/8	125	260	325	400	530	600	750	800	970					
	7/64	200	200	265	315	410	470	580	610	720	900				
	3/32	250	155	200	240	315	360	440	480	560	690	750			
USBT-HS & TSBT-HS	5/64	400	100	130	155	210	235	280	310	360	440	460	510	580*	
	1/4	40	1040	1350	1580	2000	2350								
	3/16	80	680	930	1120	1550	1775	2400	2300						
	1/8	250	320	42	510	700	790	1020	1090	1300	1650	1800			
	7/64	300	220	280	325	430	500	630	685	800	1000	1100	1200		
3/32	650	175	225	270	370	400	510	540	650	800	870	930	1050	1300	

For Kg/Hr Multiply by .454

* CRN not available



REPAIRABLE STAINLESS STEEL DURA-FLO INVERTED BUCKET STEAM TRAPS

Pressures to 650 PSIG (45 barg)
Temperatures to 497°F (258°C)

APPLICATIONS

- Steam Lines
- Process Equipment
- Steam Cookers
- Steam Heated Vats
- Pressing Machinery
- Unit Heaters
- Oil Preheaters
- Converters
- Coils
- Rotating Drum

Canadian Registration # OE10389.52

For information on Big Block UMTVS-BB Connector
SEE PAGE 116

Easy Trap Replacement — Universal two bolt swivel mounting option simplifies removal from system.

Simple Installation — Stainless mounting Block mounts permanently into system. Trap installs via two bolt universal mount connection.

Hardened Chrome Steel Valve and Seat — Long life and maximum corrosion resistance.

Stainless Steel Bucket — Long lasting, rugged and naturally resistant to water hammer.

Inexpensive — Low maintenance and initial cost.

Stainless Steel Body — Durable heavy wall construction provides years of reliable service and resists corrosion and freezing.

Suitable for Wide Variety of Loads/Applications — Horizontal models in three body sizes.

Resists Dirt and Scale — Valve and seats positioned at top of traps ensure long service.

Repairable Model (TSBT_R & USBT_R) — Removable cover allows pressure change or repair with existing Dura-Flo PCA kits.

MODELS

NPT CONNECTION, REPAIRABLE

- TSBT-LR – Low Capacity, 200 PSIG
- TSBT-MR – Medium Capacity, 400 PSIG
- TSBT-HR – High Capacity, 650 PSIG

UMT CONNECTION, REPAIRABLE

- USBT-LR – Low Capacity, 200 PSIG
- USBT-MR – Medium Capacity, 400 PSIG
- USBT-HR – High Capacity, 650 PSIG

UMT CONNECTOR BLOCKS

- UMTC—Standard connector (1/2" & 3/4" only)
- UMTCY-RH—Right Hand Connector w/Y strainer*
- UMTCY-LH—Left Hand Connector w/Y strainer*
- UMTVS-BB—Connector with Isolation Valves, Strainer, Blowdown Valve and Test Port

OPERATION

After trap is installed and primed, steam entering the trap collects in the top of the bucket, floating the bucket and forcing the valve into its seat. As condensate begins to flow into the trap, steam and air are forced from the bucket. This causes the bucket to begin losing buoyancy, tending to pull the valve from its seat. When enough condensate has

entered the trap, displacing the steam and air, the bucket drops, pulling the valve from the seat and allowing condensate and air to discharge. As the flow of condensate stops, steam enters the trap and re-floats the bucket, forcing the valve into its seat. The cycle then repeats as more condensate reaches the trap.

REPAIRABLE STAINLESS STEEL DURA-FLO INVERTED BUCKET STEAM TRAPS

SPECIFICATION

Furnish and install as shown on the plans, inverted bucket traps capable of discharging condensate, air and other non-condensable gases without loss of steam. These traps shall have a stainless steel sealed body, hardened chrome steel valve and seat and an all stainless steel linkage and bucket. It shall also have a universal mount connection option. The repairable traps shall have a removable cover to allow repair or orifice change.

MAXIMUM OPERATING CONDITIONS

PMO: Max. Operating Pressure See Orifice Selection
 TMO: Max. Operating Temperature Saturated at PMO
 PMA: Max. Allowable Pressure -
 LR 200 psig (13.8 barg) at 450°F (232°C)
 MR 420 psig (29.0 barg) at 450°F (232°C)
 HR 650 psig (44.8 barg) at 497°F (258°C)
 TMA: Max. Allowable Temperature 800°F (425°C)

MATERIALS OF CONSTRUCTION

BodyASTM A351 CF8
 CoverASTM A351 CF8
 Bucket.....AISI 304 SS
 Bucket Clip.....AISI 304 SS
 LeverAISI 304 SS
 Inlet TubeAISI 304 SS
 ValveHardened Chrome Steel AISI D3
 Valve SeatHardened Chrome Steel AISI D3
 Swivel ConnectorAISI 304 SS
 Cover GasketSpiral Wound 304 SS with Grafoil

Maximum Capacity—(lbs/hr)

Trap	Orifice		Differential Pressure												
			5	10	15	30	40	70	80	125	200	250	300	400	650
	Size	MOP	(0.34)	(0.69)	(1.03)	(2.07)	(2.76)	(4.83)	(5.52)	(8.62)	(13.79)	(17.24)	(20.69)	(27.59)	(44.83)
TSBT-LR, USBT-LR	3/32	200	85	120	145	200	230	300	325	400	500				
TSBT-MR, USBT-MR	1/4	15	800	920	1040										
	3/16	30	540	690	800	1000									
	5/32	70	390	490	560	700	790	940							
	1/8	125	260	325	400	530	600	750	800	970					
	7/64	200	200	265	315	410	470	580	610	720	900				
	3/32	250	155	200	240	315	360	440	480	560	690	750			
TSBT - HR USBT-HR	5/64	400	100	130	155	210	235	280	310	360	440	460	510	580	
	1/4	40	1040	1350	1580	2000	2350								
	3/16	80	680	930	1120	1550	1775	2400	2300						
	1/8	250	320	42	510	700	790	1020	1090	1300	1650	1800			
	7/64	300	220	280	325	430	500	630	685	800	1000	1100	1200		
	3/32	650	175	225	270	370	400	510	540	650	800	870	930	1050	1300

For Kg/Hr Multiply by .454

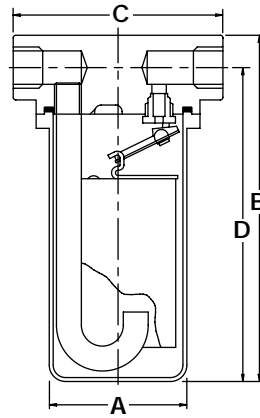

TSBT REPAIRABLE SERIES

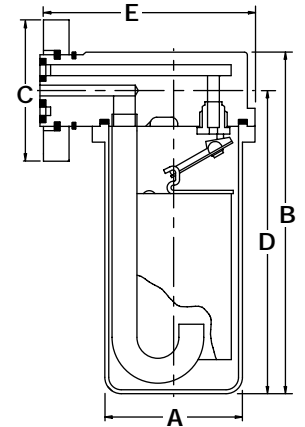

USBT REPAIRABLE SERIES

Connections: 3/8" - 1" NPT

DIMENSIONS inches (mm)
AND WEIGHTS pounds (kg)

Model	Inches (mm)				Weight lbs(kg)
	A	B	C	D	
TSBT-LR	2 5/8 (73)	6 1/4 (159)	4 7/8 (110)	5 5/8 (141)	6.6 (3.0)
TSBT-MR	2 5/8 (73)	7 1/4 (184)	4 7/8 (110)	6 1/8 (166)	7.2 (3.2)
TSBT-HR	4 1/8 (104.8)	9 1/2 (241.3)	5 (127)	8 1/2 (215.9)	22 (10)

Connections:
Universal Mount Two Bolt Swivel Connection

DIMENSIONS inches (mm) AND WEIGHTS pounds (kg)

Model	Inches (mm)					Weight lbs(kg)
	A	B	C	D	E	
USBT-LR	2 1/2 (73)	6 3/8 (161)	2 3/4 (70)	5 5/8 (143)	4 1/4 (108)	7.25 (3.3)
USBT-MR	2 1/2 (73)	7 3/8 (186)	2 3/4 (70)	6 3/8 (168)	4 1/4 (108)	8 (3.6)
USBT-HR	4 1/8 (104.8)	9 3/4 (247.7)	2 3/4 (70)	8 3/4 (222.3)	6 1/4 (158.8)	25 (11.33)