



TYPE S TRANSFER VALVE

- **Changeover** automatic, demand-controlled for optimum performance, expanded rangeability
- **Protection** against high pressure/low flow erosion of valve parts
- **Reduction** of overall maintenance and operating cost

The Class S Transfer Valve is a pneumatic switch used to select which of two parallel control circuits will be active. It prevents oscillation from one circuit to another. It is usable in many types of control loops and has been used primarily to provide a two-controller pressure reducing station for handling extremely wide load variations (beyond the rangeability of a single controller) and to minimize the extreme throttling and erosive effect on a single control valve.

HOW S-TRANSFER SYSTEMS WORK

The minimum adjustment of the piston spring positions the spool so that communication exists between port "A" and port "B". A reference signal from port "B" is fed to the top of the small piston (port "F"). The low flow circuit (small control valve) for low load operation is now in control.

LOW FLOW CIRCUIT TO HIGH FLOW CIRCUIT

As the demand increases to the load point at which the low flow valve cannot handle the load, the controlled pressure begins to drop. When the controlled pressure drops to the setpoint of the high load circuit control pilot, the output pressure from this pilot increases and is supplied to ports "C" and "E". The signal supply pressure to port "E" acts on the large piston and produces an upward force which must exceed the downward force produced by the piston spring and the reference signal on the small piston. When this occurs, the spool moves upward so that port "A" is sealed, port "B" is vented (low flow valve closes) and communication exists between ports "C" and "D". The high flow valve (large valve for high load operation) is now in control. Note that the reference signal to port "F" is vented. The point at which this transfer occurs (transfer valve setpoint) may be varied over a range as indicated on the graph below.

HIGH FLOW CIRCUIT TO LOW FLOW CIRCUIT

As the load begins to decrease and the controlled pressure begins to rise, the output of the high flow circuit pilot to ports "C" and "E" begins to drop. When it drops by some predetermined amount (transfer deadband), the spool will transfer back to its original position. The point at which the spool will transfer back will be somewhat lower in pressure than the setpoint because of the loss of the reference signal on the small piston. This transfer deadband is designed to prevent oscillation from one circuit to another. It is predetermined by the value of the reference signal at the time of transfer from the primary to the secondary circuit and is illustrated by the shaded area on the graph.

NOTE 1: Transfer deadband is the same for all set points between minimum and maximum.

NOTE 2: In the installations shown, the valves are normally closed and the pilots reverse acting. In these installations, normally open valves and direct acting pilots cannot be used. Selection of valves and pilots to be used with the transfer valve must be made carefully and the operation of the complete cycle in both directions considered.

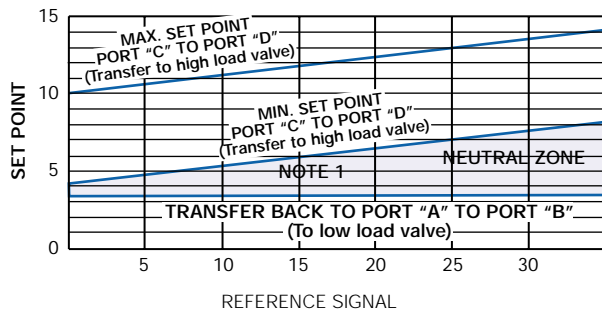

Note 1: Transfer dead band. This band width remains the same for all set points between min. and max.

TYPE S TRANSFER VALVE SPECIFICATIONS

All Threaded Connections: 1/4" pipe thread except vent
 Vent: 1/8" N.P.T. (vent hole in plug)
 Maximum Height: 1111/16"
 Width/Depth: 21/2

MATERIALS OF CONSTRUCTION

Spring CaseCast Aluminum
 Valve BodyAluminum
 Small Piston.....Aluminum
 Sleeve and Spool AssemblyStainless Steel
 Large PistonAluminum
 Bottom FlangeAluminum
 O-Rings and GasketsSynthetic rubber

- CONN. A Primary Pilot Output Pressure Connection
- CONN. B Transfer Valve Primary Output Pressure Connection
- CONN. C Secondary Pilot Output Pressure Connection
- CONN. D Transfer Valve Secondary Output Pressure Connection
- CONN. E Connection for Large Piston Loading Pressure from Secondary Pilot Output (Transfer Valve Set Point)
- CONN. F Connection for Small Piston Loading Pressure from Transfer Valve Primary Output (Reference Signal)

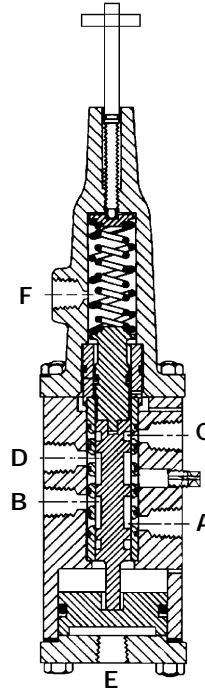

Parallel Pressure Control System using two pressure controllers and two control valves.

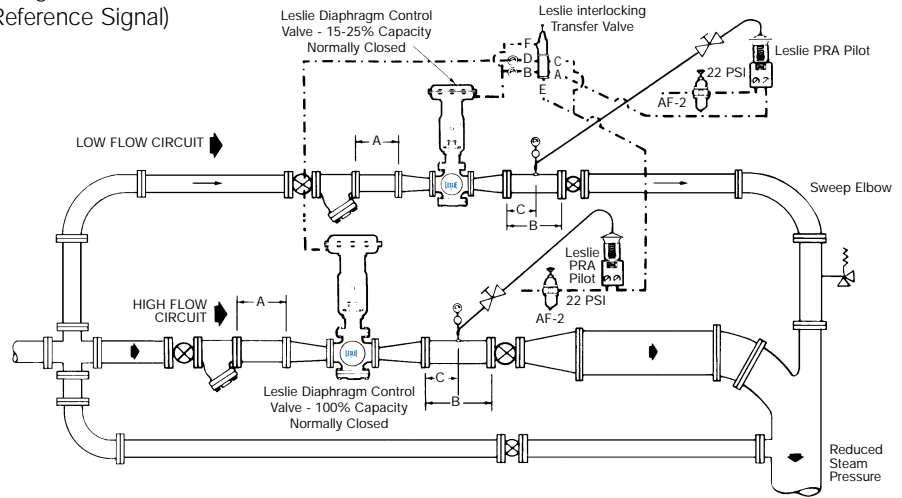

**FOR REDUCED PRESSURES
BELOW 30 PSI**

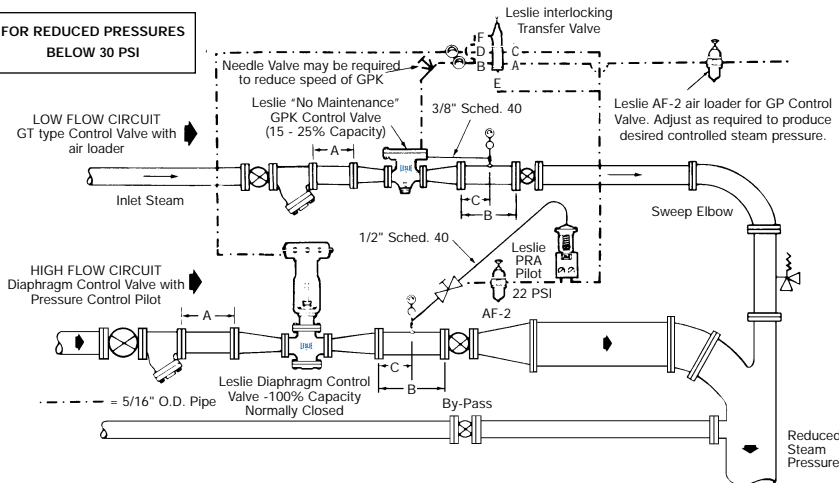

Parallel Pressure Control System using one diaphragm control valve and one air loaded GT Type Regulator.