



# LESLIE DESUPERHEATERS

SIZES 1/2" - 16"  
ANSI Class 150 to 2500

- Fabricated and forged constructions
- High quality stuffing box
- Variable nozzle type
- Wide range of Cv (Kv) capacities available
- Special nozzle combinations available

## APPLICATION DATA

- Boiler superheaters
- Boiler reheaters
- Turbine bleed steam
- Pressure reducing valve outlet steam
- Process steam
- Process gases

TABLE 1 Cv (Kv) CAPACITY RANGES

Size	Standard capacity ranges for Models 13, 18, 23, 24, 28, 33, 34, 38 and 48					
1/2" (16mm)	6A	Cv = 0.0752	Kv = 0.0648	9A	Cv = 0.1128	Kv = 0.0972
	6B	Cv = 0.1587	Kv = 0.1368	9B	Cv = 0.2380	Kv = 0.2052
	6C	Cv = 0.3007	Kv = 0.2592	9C	Cv = 0.4510	Kv = 0.3888
	6D	Cv = 0.5860	Kv = 0.5052	9D	Cv = 0.8790	Kv = 0.7578
	6Dx	Cv = 1.1602	Kv = 1.0002	9Dx	Cv = 1.7403	Kv = 1.5003
1" (25mm)	6E	Cv = 1.9022	Kv = 1.6398	9E	Cv = 2.8533	Kv = 2.4597
	6F	Cv = 2.8397	Kv = 2.4480	9F	Cv = 4.2595	Kv = 3.6720
	6G	Cv = 6.0322	Kv = 5.2002	9G	Cv = 9.0483	Kv = 7.8003
	6H	Cv = 9.3960	Kv = 8.1000	9H	Cv = 14.0940	Kv = 12.1500
	6K	Cv = 13.4885	Kv = 11.6280	9K	Cv = 20.2327	Kv = 17.4420

Flow capacity limitations are:

- Model 18, 24 and 38 with a maximum water flow capacity of 883 ft<sup>3</sup>/hr. (25 m<sup>3</sup>/hr.) in continuous service.
- Model 13, 33, 34 and 48 with a maximum water flow capacity of 1766 ft<sup>3</sup>/hr. (50 m<sup>3</sup>/hr.) in continuous service.
- Model 23 with a maximum water flow capacity of 3531 ft<sup>3</sup>/hr. (100 m<sup>3</sup>/hr.) in continuous service.

# LESLIE DESUPERHEATERS

## Definition

$$K_v = Q \sqrt{\frac{S.G.}{\Delta P}} \quad \begin{matrix} Q = \text{ft}^3/\text{hr. (m}^3/\text{hr.)} \\ \Delta p = \text{psi (bar)} \end{matrix} \quad \frac{C_v}{1.156} = K_v$$

## Multiple nozzle heads

The A.T. - Temp Desuperheater may be equipped with a variety of spray heads. The uniform body threading accepts spray cylinder heads with a wide range of Cv (Kv) values.

Standard configurations are with either 6 or 9 equally sized spray nozzles but combinations are available.

This feature enables the A.T. - Temp Desuperheater to be customized to specific system requirements. Consult Leslie Controls or your local representative for details.

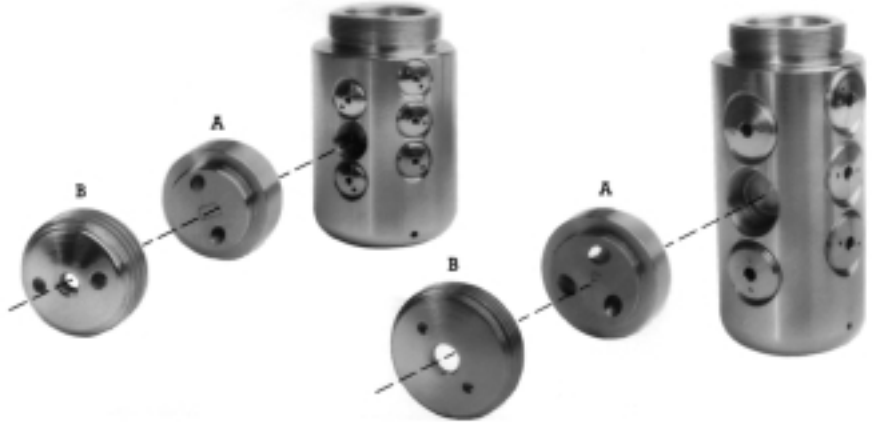

## Sizing formula

Every desuperheating station is a mixing point where there is a heat and mass balance.

The universal formula is:

$$G_w = G_{st} (h_1 - h_2) : (h_2 - h_w)$$

In which:

**G<sub>w</sub>** = Injection water mass

**G<sub>st</sub>** = Inlet steam mass

**h<sub>1</sub>** = Enthalpy of the inlet steam

**h<sub>2</sub>** = Enthalpy of the outlet steam

**h<sub>w</sub>** = Enthalpy of the injection water

This formula enables calculation of the quantity of water required to lower the inlet steam temperature to the set - point temperature of the outlet steam.

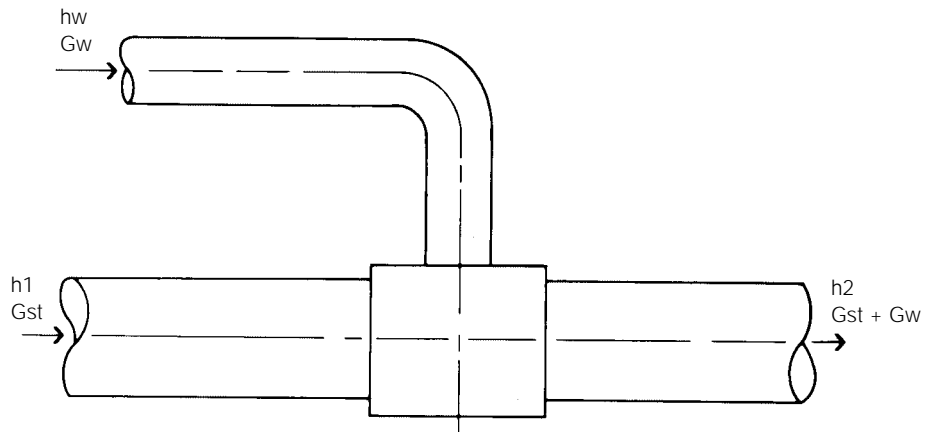

## Important system parameters

Apart from the spray quality of the atomizer (primary atomization) there are other system parameters which influence the Desuperheater stations performance. These are:

### Inlet steam velocity

At high steam velocities, water droplets are easily disintegrated. This factor contributes to the overall atomization quality (secondary atomization). The minimum acceptable steam velocity varies as a function of the nozzle size and pipe diameter. In case of doubt, consult Leslie controls.

### Water to Steam Ratio

This ratio is determined by dividing G<sub>w</sub> by G<sub>st</sub>. For system steam pressures below 15 bar, this ratio should not exceed 10% for the normal operating conditions. Systems operating between 218 and 363 psi (15 and 25 bar) can have a ratio of up to 15%. For higher pressure duties, consult Leslie controls.

### Distance to Sensor

The distance from the injection point to the temperature sensor should be 40 to 50 feet

(12 to 15 meters). Systems operating at pressures above 363 psi (25 bar) can have significantly less run to the sensor, consult Leslie controls.

### Required Straight Pipe Run

The distance from injection point to the first pipe bend is also a function of steam pressure, temperature and nozzle size. Experience has shown that in systems up to 363 psi (25 bar), 13 to 20 feet (4 to 6 meters), is an acceptable distance.

# LESLIE DESUPERHEATERS

## Actuator Sizing Formula

Units:

- D seat inch (cm)
- d stem inch (cm)
- D bal inch (cm)
- P water psi (bar)

$$F1 = p / 4 (D \text{ seat}^2 - d \text{ stem}^2) \times P \text{ water}$$

$$F2 = p / 4 (D \text{ bal}^2 - d \text{ stem}^2) \times P \text{ water}$$

$$F3 = P \text{ water} \times F \text{ friction (+ or -)}$$

## Actuator stem forces

The stem forces for the Standard Duty A.T. - Temp Desuperheater are determined by the following formula:

**Model 24/38:**  $P \text{ water} \times 62 + 1000 =$   
 Newton [P Water in psi (bar)]  
 The maximum stem force must be limited to 3372 lb/f (15kN).

**Model 34/48:**  $P \text{ water} \times 68 + 1250 =$   
 Newton [P Water in psi (bar)]  
 The maximum stem force must be limited to 11,240 lb/f (50kN).

The stem forces for the Heavy Duty A.T. - Temp Desuperheater are determined by the following formula:

**Model 18:**  $P \text{ water} \times 36 + 1000 =$   
 Newton [P Water in psi (bar)]  
 The maximum stem force must be limited to 3372 lb/f (15kN).

**Model 28:**  $P \text{ water} \times 68 + 1250 =$   
 Newton [P Water in psi (bar)]  
 The maximum stem force must be limited to 11,240 lb/f (50kN).

Special care should be taken when electric actuators are used. By their momentum of inertia these actuators can generate stem forces exceeding the specified nominal stem force during short intervals. Leslie controls supplies special spring loaded couplings for such applications.

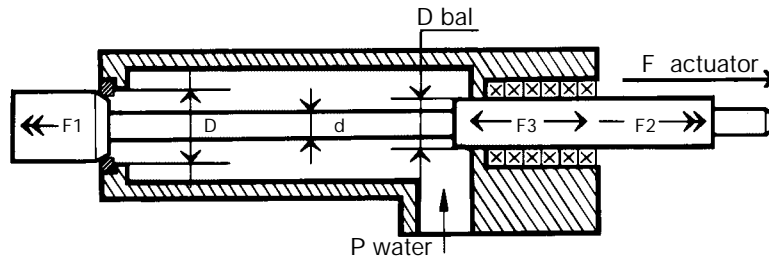

## Ordering / sizing data

Steam Desuperheaters are selected specifically against application data. For optimal sizing, the following comprehensive data should always be supplied.

### Steam Data

Inlet pressure	psi	bar
Inlet temperature	°F	°C
Outlet temperature	°F setpoint	°C setpoint
Steam flow max.	lbs/hr	t / hr
Steam flow normal	lbs/hr	t / hr
Steam flow min.	lbs/hr	t / hr

### Water Data

Water pressure	psi	bar
Water temperature	°F	°C

### General

Pipe size	inch	mm
Pipe schedule		
Required water flange position	(9) (12) (3) (6)	
It is essential not to over specify the required turndown ratio i.e.:		
	Steam flow max.	
	Steam flow min.	

Otherwise this will necessitate selection of special nozzle heads which are non - stock items. Standard stock consists of nozzles with 6 or 9 equally sized atomizers giving turndown ratios of 18:1 and 27:1 respectively, on the water flow control. Experience shows that the majority of applications fall within this range.

## Water flange positions

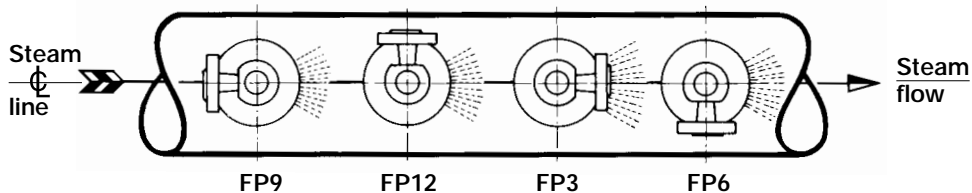

Spray water must be injected in the direction of the steam flow. To facilitate installation of the water supply line, 4 different spray head positions are

available in relation to the water connecting flange. Specification of this spray head orientation is required with the ordering data.

Leslie Controls always recommends a strainer with a mesh size of approx. 100 μ (400 μ upon request) in the water supply line to protect the A.T. - Temp Desuperheater from clogging.

# STANDARD DUTY A.T. - TEMP DESUPERHEATER

## MODEL: 38 / 48

### TECHNICAL DATA

- Size: Steam 3" (DN 80)  
Water 1"-1½" (DN 25-40)  
Steam 4" (DN 100)  
Water 1½"-2"-3" (DN 40-50-80)
- Fabricated construction
- Non / Semi balanced internals for economic actuator selection

TABLE 1 - C<sub>v</sub> (K<sub>v</sub>) CAPACITY RANGES see page 76

TABLE 2 DIMENSIONS inches (mm)

		Model 38 Q <sub>max</sub> = 883 ft <sup>3</sup> /hr (25 m <sup>3</sup> /hr.)	Model 48 Q <sub>max</sub> = 1766 ft <sup>3</sup> /hr (50 m <sup>3</sup> /hr.)
<b>Standard length for steam line sizes up to 12" (DN300)</b>			
A	A through Dx	15.0 (380)	15.7 (399)
	E through K	15.7 (399)	—
B	A through Dx	17.2 (436)	18.7 (476)
	E through K	18.7 (476)	—
<b>Option: standard length for steam line sizes 14" (DN350) and higher</b>			
A	A through Dx	22.8 (580)	23.6 (599)
	E through K	23.6 (599)	—
B	A through Dx	25.0 (636)	26.6 (676)
	E through K	26.6 (676)	—
C		7.9 (200)	7.9 (200)
D		12.0 (305)	15.6 (395)
E		8.3 (210)	9.3 (236)
F		1.3 (32)	1.3 (32)
G		M12 x 1.75	M16 x 2.00
H		M70 x 2.00	M90 x 2.00
K		2.8 (71) + 0 (0) / .008 (-0.2)	3.6 (91) + 0 (0) / .008 (-0.2)
L	Depending on size and class	min. 5.9 (150)	min. 7.9 (200)
M	<b>minimum</b>	2.6 (66.0)	3.2 (80.0)
N		2.4 (60.3) x 0.4 (11.17)	2.9 (73) x 0.6 (14.0)
P		2.5 (64.0)	3.1 (78.0)

Note: Dimensions may be subject to change without prior notification. Leslie Controls will provide a certified dimensional drawing upon request.

TABLE 3 FLANGE CONNECTIONS

FLANGE	Model 38 Q <sub>max</sub> = 883 ft <sup>3</sup> /hr (25 m <sup>3</sup> /hr.)	Model 48 Q <sub>max</sub> = 1766 ft <sup>3</sup> /hr (50 m <sup>3</sup> /hr.)
Steam flange	3" class 150	4" class 150
	class 300	class 300
	class 600	class 600
	class 900	class 900
	class 1500	class 1500
	DN80 - PN 25/40	DN100 - PN 25/40
	PN 64	PN 64
	PN 100	PN 100
Water flange	1" - 1½"	1½" - 2" - 3"
	DN 25 - 40	DN 40 - 50 - 80
	Pressure classes as per water data requirements	Pressure classes as per water data requirements

### STROKE

- For nozzles A - B - C - D - Dx: 2.2" (55mm) Pipeline diameter min. 6"
  - For nozzles E - F - G - H - K: 3.5" (90mm) Pipeline diameter min. 8"
- In case of deviating line size, consult Leslie Controls.

### MATERIALS OF CONSTRUCTION

- ASTM SA 105 / SA 106 Gr.B or SA 182 F11 / SA 335 P11
- DIN C22.8 / St 35.8.III or DIN 1.7335
- Other materials upon request

### APPLICABLE CODES

- ASME/ ANSI B16.34 class 150 to 1500
- DIN 2401 class PN 25 to 250
- Butt weld connections to ANSI B16.25 or DIN 2559

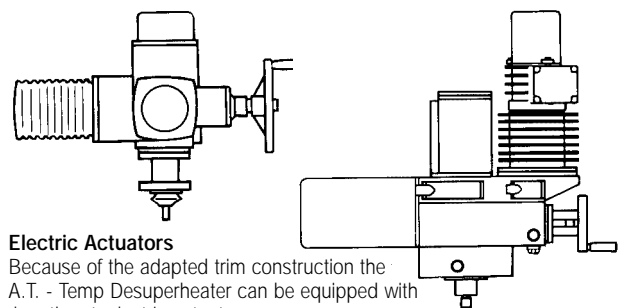
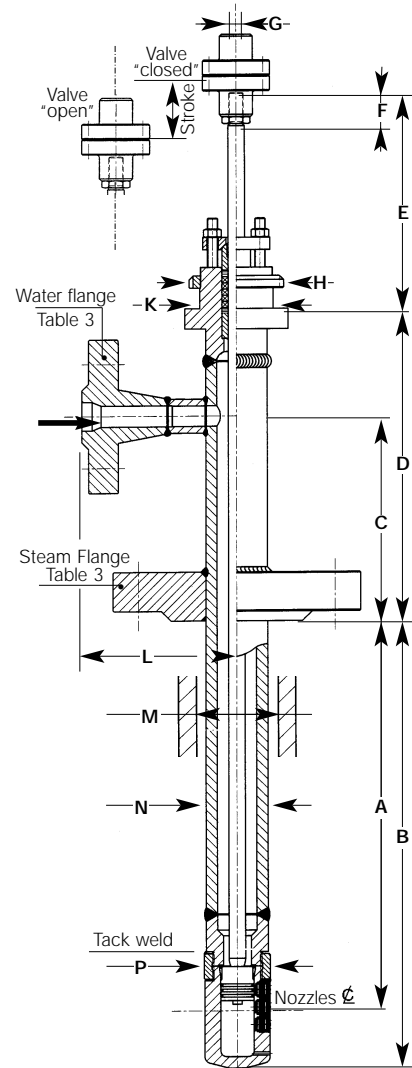

### Electric Actuators

Because of the adapted trim construction the A.T. - Temp Desuperheater can be equipped with 'low-thrust' electric actuators.

Each actuator-valve assembly is fully function tested at the Leslie Controls factory. A functional test certificate is issued for all valves supplied.

# HEAVY DUTY A.T. - TEMP DESUPERHEATER

## MODEL: 18 / 54 and 28 / 64

### TECHNICAL DATA

- Size: Steam 3" (DN80)  
Water 1"-1½" (DN25-40)  
Steam 4" (DN100)  
Water 1½"-2"-3" (DN40-50-80)
- Forged construction
- Semi balanced internals for economic actuator selection

### MATERIALS OF CONSTRUCTION

- ASTM SA 182 F22 or DIN 1.7380
- ASTM SA 182 F347H or DIN 1.4550
- ASTM SA 182 F91 or DIN 1.4903
- Other materials upon request

### APPLICABLE CODES

- ASME/ ANSI B16.34 class 900 to 2500

TABLE 1 - Cv (Kv) CAPACITY RANGES see page 76

TABLE 2 DIMENSIONS inches (mm)

		Model 18 Qmax = 883 ft <sup>3</sup> /hr (25 m <sup>3</sup> /hr.)	Model 28 Qmax = 1766 ft <sup>3</sup> /hr (50 m <sup>3</sup> /hr.)
Standard length for steam line sizes up to 12" (DN300)			
A	A through Dx	15.0 (380)	15.7 (399)
	E through K	15.7 (399)	
B	A through Dx	17.2 (436)	18.7 (476)
	E through K	18.7 (476)	
C		7.9 (200)	9.8 (250)
		9.5 (240) for model 54	
D		12.0 (305)	14.0 (355)
E		8.3 (210)	9.8 (250)
F		1.3 (32)	1.3 (32)
G		M12 x 1.75	M16 x 2.00
H		M80 x 2.00	M90 x 2.00
K		3.2 (81) + 0 (0) / .008 (-0.2)	3.6 (91) + 0 (0) / .008 (-0.2)
L	Depending on size and class	5.9 (150)	7.9 (200)
		9.8 (250) for model 54	9.8 (250)/11.8 (300) for model 64
M	minimum	2.6 (66.0)	3.2 (80.0)
N		2.4 (60.3) x 0.5 (12.6)	2.9 (73.0) x 0.6 (14.0)
P		2.5 (64.0)	3.1 (78.0)

Note: Dimensions may be subject to change without prior notification. Leslie Controls will provide a certified dimensional drawing upon request.

TABLE 3 FLANGE CONNECTIONS

FLANGE	Model 18 Qmax = 883 ft <sup>3</sup> /hr (25 m <sup>3</sup> /hr.)	Model 28 Qmax = 1766 ft <sup>3</sup> /hr (50 m <sup>3</sup> /hr.)
Steam flange	3" class 900	4" class 900
	class 1500	class 1500
	class 2500	class 2500
	DN80 - PN 160	DN100 - PN 160
	PN 250	PN 250
	PN 320	PN 320
Water flange	1" - 1½"	1½" - 2" - 3"
	DN 25 - 40	DN 40 - 50 - 80
	Pressure classes as per water data requirements	Pressure classes as per water data requirements

Note: Other pressure classes upon request.

### STROKE

- For nozzles A - B - C - D - Dx: 2.2" (55mm)  
minimum steam line size: 6" (DN150)
- For nozzles E - F - G - H - K: 3.5" (90mm)  
minimum steam line size: 8" (DN200)

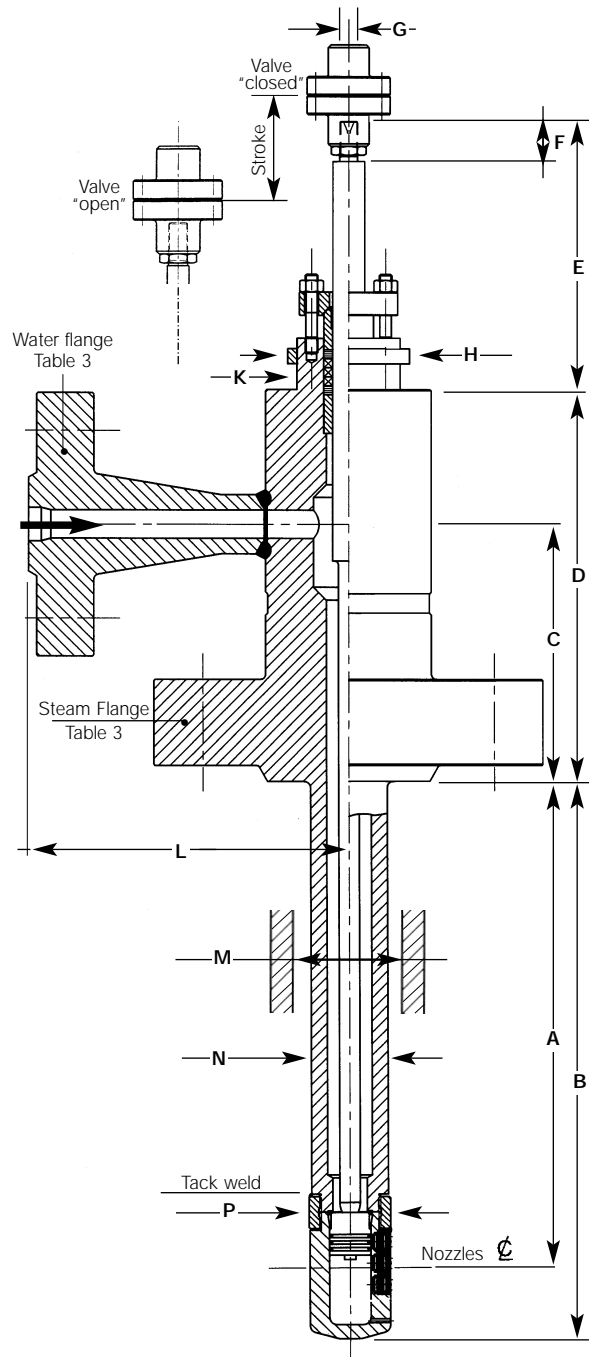

# STANDARD DUTY A.T.S.A. - TEMP DESUPERHEATER

## MODEL: 24 / 34

### TECHNICAL DATA

- Size: Steam 6" - 8" (DN150-200)  
Water 1" - 3" (DN25-80)  
Steam assist 1½" - 4" (DN40-100)
- Fabricated construction

### MATERIALS OF CONSTRUCTION

- ASTM SA 105 / SA 106 Gr.B or DIN C22.8 / St 35.8.III
- ASTM SA 182 F11 / SA 335 P 11 or DIN 1.7335
- Other materials upon request

### APPLICABLE CODES

- ASME/ ANSI B16.34 class 150 to 1500
- DIN 2401 class PN25 to 250
- Buttweld connections to ANSI B16.25 or DIN 2559

TABLE 1 - Cv (Kv) CAPACITY RANGES see page 76

TABLE 2 DIMENSIONS inches (mm)

		Model 24 Qmax = 883 ft <sup>3</sup> /hr (25 m <sup>3</sup> /hr.)	Model 34 Qmax = 1766 ft <sup>3</sup> /hr (50 m <sup>3</sup> /hr.)
<b>Standard length for steam line sizes 14" (DN350) and higher</b>			
A	A through Dx	22.8 (580)	—
	E through K	23.6 (599)	23.6 (599)
B	A through Dx	25.0 (636)	—
	E through K	26.6 (676)	26.6 (676)
C		11.4 (290)	17.7 (450)
D		15.6 (395)	24.6 (625)
E		8.3 (210)	9.2 (236)
F		1.3 (32)	1.3 (32)
G		M12 x 1.75	M16 x 1.75
H		M70 x 2.00	M90 x 2.00
K		2.8 (71) + 0 (0) / .008 (-0.2)	3.6 (91) + 0 (0) / .008 (-0.2)
L	Depending on size and class	min. 5.9 (150)	min. 7.87 (200)
M	minimum	4.1 (105)	6.89 (175)
N		3.9 (100)	6.63 (168.3)
P		2.5 (64.0)	3.1 (78.0)
S		5.9 (150)	5.9 (150)
T		9.8 (250)	9.8 (250)

Note: Dimensions may be subject to change without prior notification. Leslie Controls will provide a certified dimensional drawing upon request.

TABLE 3 FLANGE CONNECTIONS

FLANGE	Model 24 Qmax = 883 ft <sup>3</sup> /hr (25 m <sup>3</sup> /hr.)	Model 34 Qmax = 1766 ft <sup>3</sup> /hr (50 m <sup>3</sup> /hr.)
Steam flange*	6" class 150	8" class 150
	class 300	class 300
	class 600	class 600
	DN150 - PN 25/40	DN200 - PN 25/40
	PN 64	PN 64
	PN 100	PN 100
Water flange	1" - 1½"	1½" - 3"
	DN 25 - 40 Pressure classes as per requirements up to 1500#	DN 40 - 80 Pressure classes as per requirements up to 1500#
Steam assist flange	1½" - 2"	2" - 4"
	DN 40 - 50 Pressure classes as per requirements up to 1500#	DN 50 - 100 Pressure classes as per requirements up to 1500#

\* Other pressure classes upon request.

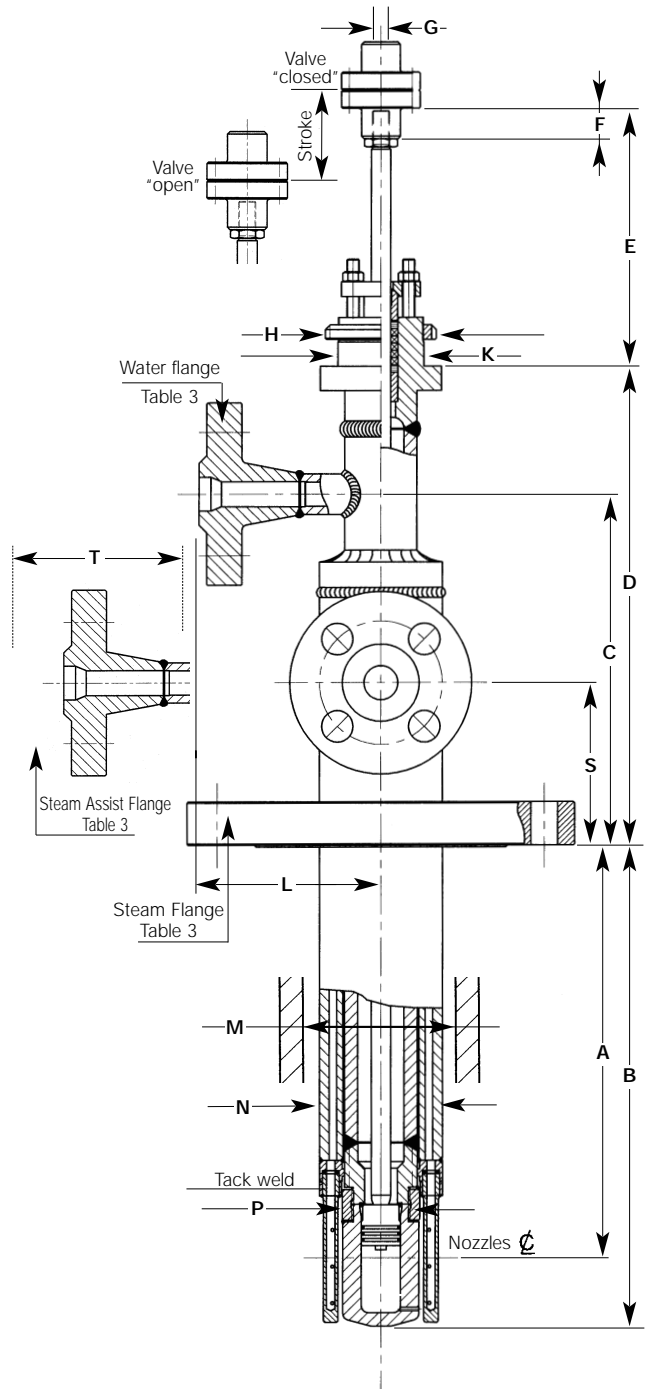

### STROKE

- For nozzles A - B - C - D - Dx: 2.2" (55mm)
- For nozzles E - F - G - H - K: 3.5" (90mm)  
minimum steam line size: 8" (DN200)

# HEAVY DUTY QUE - TEMP DESUPERHEATER

## MODEL: 33 / 43

### TECHNICAL DATA

- Size: Steam 3" (DN 80)  
Water 1" - 1½" (DN 25-40)  
Steam 4" (DN 100)  
Water 1½" - 2" - 3" (DN 40-50-80)
- Fabricated construction

### MATERIALS OF CONSTRUCTION

- ASTM SA 105 / SA 106 Gr.B or DIN C22.8 / St. 35.8.III
- ASTM SA 182 F11 / SA 335 P11 or DIN 1.7335
- Other materials upon request

### APPLICABLE CODES

- ASME/ ANSI B16.34 class 150 to 1500
- DIN 2401 class PN 25 to 250
- Buttweld connections to ANSI B16.25 or DIN 2559

TABLE 1 - Cv (Kv) CAPACITY RANGES see page 76

TABLE 2 DIMENSIONS inches (mm)

		Model 33 Qmax = 1766 ft <sup>3</sup> /hr (50 m <sup>3</sup> /hr.)	Model 43 Qmax = 3532 ft <sup>3</sup> /hr (100 m <sup>3</sup> /hr.)
<b>Standard length for steam line sizes up to 12" (DN300)</b>			
A	A through Dx	15.0 (380)	15.7 (399)
	E through K	15.7 (399)	—
B	A through Dx	17.2 (436)	18.7 (476)
	E through K	18.7 (476)	—
<b>Option: standard length for steam line sizes 14" (DN350) and higher</b>			
A	A through Dx	22.8 (580)	23.6 (599)
	E through K	23.6 (599)	—
B	A through Dx	25.0 (636)	26.6 (676)
	E through K	26.6 (676)	—
C		7.9 (200)	7.9 (200)
L	Depending on size and pressure class	min. 5.9 (150)	min. 7.9 (200)
M	<b>minimum</b>	2.6 (66.0)	3.2 (80.0)
N		2.4 (60.3) x 0.4 (11.1)	2.9 (73.3) x 0.6 (14.0)
P		2.5 (64.0)	3.1 (78.0)

Note: Dimensions may be subject to change without prior notification.  
Leslie Controls will provide a certified dimensional drawing upon request.

TABLE 3 FLANGE CONNECTIONS

FLANGE	Model 33 Qmax = 1766 ft <sup>3</sup> /hr (50 m <sup>3</sup> /hr.)	Model 43 Qmax = 3532 ft <sup>3</sup> /hr (100 m <sup>3</sup> /hr.)
Steam flange	3" class 150	4" class 150
	class 300	class 300
	class 600	class 600
	class 900	class 900
	class 1500	class 1500
	DN80 - PN 25/40	DN100 - PN 25/40
	PN 64	PN 64
	PN 100	PN 100
Water flange	1" - 1½" DN 25 - 40 Pressure classes as per water data requirements	1½" - 2" - 3" DN 40 - 50 - 80 Pressure classes as per water data requirements

### MINIMUM STEAM PIPE SIZE

- For nozzles A - B - C - D - Dx: 6" (152.4mm) (DN150)
- For nozzles E - F - G - H - K: 8" (203.2mm) (DN200)

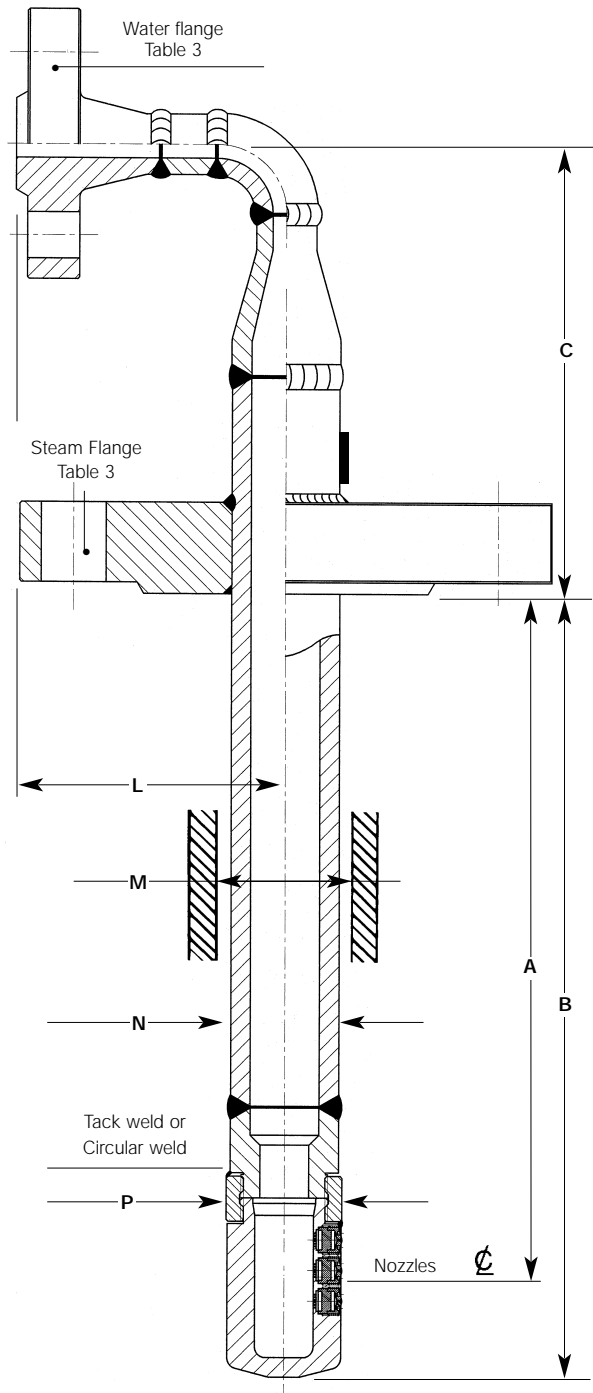

# HEAVY DUTY A.T. - TEMP DESUPERHEATER MODELS 13 / 23

LINEAR

## TECHNICAL DATA

- Size: Steam 3" (DN80)  
Water 1"-1½" (DN25-40)  
Steam 4" (DN100)  
Water 1½"-2"-3" (DN40-50-80)
- Forged construction

## MATERIALS OF CONSTRUCTION

- ASTM SA 182 F22 or DIN 1.7380
- ASTM SA 182 F347H or DIN 1.4550
- ASTM SA 182 F91 or DIN 1.4903
- Other materials upon request

## APPLICABLE CODES

- ASME/ ANSI B16.34 class 900 to 2500
- DIN 2401 class PN 160 to 400
- Butt weld connections to ANSI B16.25 or DIN 2559

TABLE 1 - Cv (Kv) CAPACITY RANGES see page 76

TABLE 2 DIMENSIONS inches (mm)

		Model 13 Qmax = 1766 ft <sup>3</sup> /hr (50 m <sup>3</sup> /hr.)	Model 23 Qmax = 3532 ft <sup>3</sup> /hr (100 m <sup>3</sup> /hr.)
Standard length for steam line sizes up to 12" (DN300)			
A	A through Dx	15.0 (380)	15.7 (399)
	E through K	15.7 (399)	—
B	A through Dx	17.2 (436)	18.7 (476)
	E through K	18.7 (476)	—
C		7.9 (200)	7.9 (200)
D		12.0 (305)	14.0 (355)
L	Depending on size and pressure class	5.9 (150)	7.9 (200)
M	minimum	2.6 (66.0)	3.2 (80.0)
N		2.4 (60.3) x 0.5 (12.6)	2.9 (73.3) x 0.6 (14.0)

Note: Dimensions may be subject to change without prior notification. Leslie Controls will provide a certified dimensional drawing upon request.

TABLE 3 FLANGE CONNECTIONS

FLANGE	Model 13 Qmax = 1766 ft <sup>3</sup> /hr (50 m <sup>3</sup> /hr.)	Model 23 Qmax = 3532 ft <sup>3</sup> /hr (100 m <sup>3</sup> /hr.)
Steam flange	3" class 900	4" class 900
	class 1500	class 1500
	class 2500	class 2500
	DN80 - PN 160	DN100 - PN 160
	PN 250	PN 250
	PN 320 PN 400	PN 320 PN 400
Water flange	1" - 1½" DN 25 - 40 Pressure classes as per water data requirements	1½" - 2" - 3" DN 40 - 50 - 80 Pressure classes as per water data requirements

## MINIMUM STEAM PIPE SIZE

- For nozzles A - B - C - D - Dx: 6" (152.4mm) (DN150)
  - For nozzles E - F - G - H - K: 8" (203.2mm) (DN200)
- In case of smaller pipe size, please consult Leslie Controls.

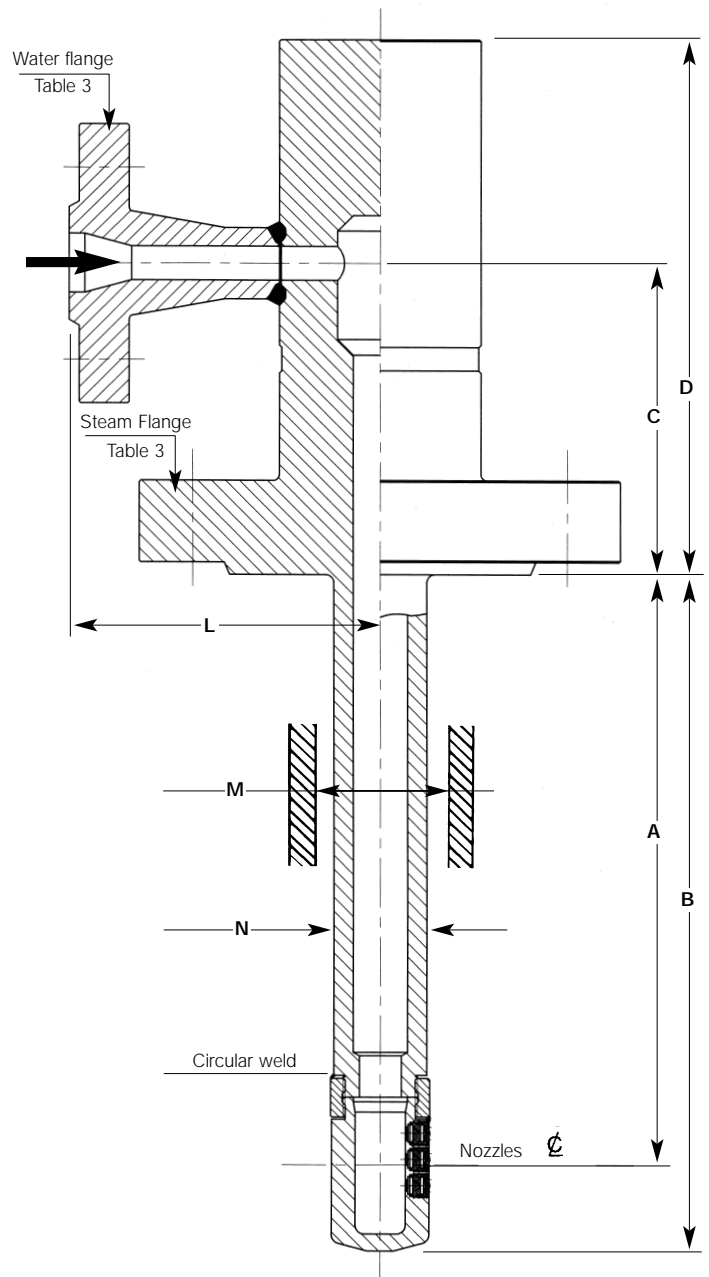



# SMALL PIPE INLINE DESUPERHEATER (SPID)

## MODEL: 88

- Fabricated construction
- Special design for small steam lines with minimal steam pressure losses
- Steam control within 43°F (6°C) of saturation temperature and ± 1% of controller range
- Venturi type vena contracta
- Wide range of Cv (Dv) capacities

### APPLICATIONS

- Turbine gland sealing,
- Air ejectors,
- Nox steam for gas turbines,
- House steam,
- Drum dryers,
- Tire molds,
- Vulcanizing equipment and cooking kettles

### TECHNICAL DATA

- Size: Steam 1½" - 4" (DN40 - DN100)  
Water 1/2" - 1" (DN15 - DN25)

### MATERIALS OF CONSTRUCTION

- ASTM SA 182 F11 / SA 335 P11 or DIN 1.7335
- Other materials upon request

### APPLICABLE CODES

- ASME/ ANSI B16.34 class 150 to 600
- DIN 2401 class PN16 to PN100
- Butt weld connections to ANSI B16.25 or DIN 2559

## SMALL PIPE INLINE DESUPERHEATER ORDERING CODE

Class	Standard	Body Rating			End Connection				Body Size	Cv Con- nection	Water Flange Rating			Water Connection	Approvals	
<b>8</b>	<b>A</b>	<b>1</b>	<b>5</b>	<b>0</b>	<b>F</b>	<b>0</b>	<b>0</b>	<b>0</b>	<b>B</b>	<b>1</b>	<b>1</b>	<b>5</b>	<b>0</b>	<b>F</b>	<b>C</b>	<b>E</b>
1	2	3	4	5	6	7	8	9	10	11	12	13	14	15	16	17

<b>Class</b> - Position 1 8 = Series 80000
<b>Standard</b> - Position 2 A = ANSI
<b>Body Rating</b> - Position 3 - 5 150 = Class 150 300 = Class 300 600 = Class 600
<b>End Connections</b> - Position 6 - 9 F000 = Flanged W040 = Butt Weld End Sch 40 W080 = Butt Weld End Sch 80 W100 = Butt Weld End Sch 100 W120 = Butt Weld End Sch 120 W160 = Butt Weld End Sch 160

<b>Body Size</b> - Position 10 B = 1½" (15mm) C = 2" (50mm) D = 3" (80mm) E = 4" (100mm)
<b>Cv Connections</b> - Position 11 1 = Cv from Capacity Table 2 = Cv from Capacity Table 3 = Cv from Capacity Table 4 = Cv from Capacity Table 5 = Cv from Capacity Table 6 = Cv from Capacity Table 7 = Cv from Capacity Table 8 = Cv from Capacity Table

<b>Water Flange Rating*</b> - Position 12 - 14 150 = Class 150 300 = Class 300 600 = Class 600
<b>Water Connection</b> - Position 15 F = Raised face flange Wafer Connection X = Other
<b>Approvals</b> - Position 16 & 17 CE = European Approvals

\* Wafer flanged ends to be equal to or greater than body rating.

# SMALL PIPE INLINE DESUPERHEATER (SPID)

## MODEL: 88

### Important system parameters

Apart from the spray quality of the atomizer (primary atomization) there are other system parameters which influence the Desuperheater stations performance. These are:

#### Water to Steam Ratio

This ratio is determined by dividing  $G_w$  by  $G_{st} = 6 : 1$ . Above this ratio, proper evaporation of the injection water cannot always be guaranteed. In case of doubt, consult Leslie Controls.

#### Distance to Sensor

The distance from the SPID Desuperheater to the temperature sensor should be 40 to 50 feet (12 to 15 meters), although the distance specific to the application is advised by Narvik at the enquiry stage. Longer distances will ensure that full evaporation of the water will take place at lower velocities.

#### Required Straight Pipe Run

The minimum pipe run, required downstream, varies with each individual application and is specified by Narvik at the enquiry stage. This straight run is needed to prevent erosion due to impingement of water droplets against pipe walls, valves and fittings.

Upstream straight run is normally  $6 \times D$  and the downstream straight run  $20 \times D$ , as a minimum.

For applications outside these limitations, consult Leslie Controls or your local representative.

### Ordering / sizing data

Steam Desuperheaters are selected specifically against application data. For optimal sizing, the following comprehensive data should always be supplied.

#### Water Data

Water pressure    psi            bar  
 Water temperature °F            °C

#### Steam Data

Inlet pressure    psi            bar  
 Inlet temperature °F            °C  
 Outlet temperature °F set point °C set point  
 Steam flow max.    lb / hr            t / hr  
 Steam flow normal lb / hr            t / hr  
 Steam flow min.    lb / hr            t / hr

#### General

Pipe size            inch            mm  
 Pipe schedule  
 Application  
 Narvik does recommend a strainer with a mesh size of approx.  $100 \mu$  in the water supply line to protect the SPID Desuperheater from clogging.

### SPID Cv (Kv) STANDARD CAPACITY RANGES

Body Size	Ports	1	2	3	4	5	6	7	8
B 1 1/2"	Cv =	0.015	0.030	0.045	0.060	0.075	0.090		
	DN40 Kv =	0.013	0.026	0.039	0.052	0.065	0.078		
C 2"	Cv =	0.030	0.060	0.090	0.120	0.150	0.180		
	DN50 Kv =	0.026	0.052	0.078	0.104	0.130	0.156		
D 3"	Cv =	0.050	0.100	0.150	0.200	0.250	0.300	0.350	0.400
	DN80 Kv =	0.043	0.086	0.129	0.172	0.215	0.258	0.302	0.345
E 4"	Cv =	0.100	0.200	0.300	0.400	0.500	0.600	0.700	0.800
	DN100 Kv =	0.086	0.172	0.258	0.344	0.430	0.516	0.602	0.688

### Sizing formula

Every desuperheating station is a mixing point where there is a heat and mass balance.

The universal formula is:

$$G_w = G_{st} (h_1 - h_2) : (h_2 - h_w)$$

In which:

- $G_w$  = Injection water mass
- $G_{st}$  = Inlet steam mass
- $h_1$  = Enthalpy of the inlet steam
- $h_2$  = Enthalpy of the outlet steam
- $h_w$  = Enthalpy of the injection water

This formula enables calculation of the quantity of water required to lower the inlet steam temperature to the set - point temperature of the outlet steam.

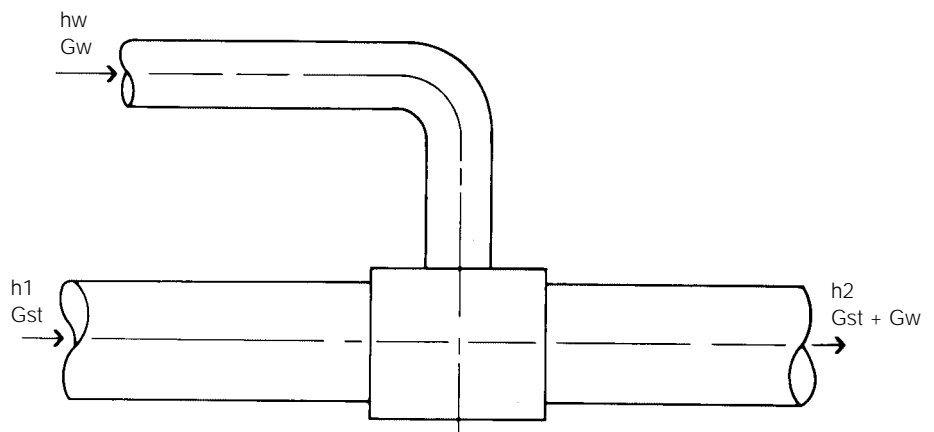

# SMALL PIPE INLINE DESUPERHEATER (SPID)

## MODEL: 88

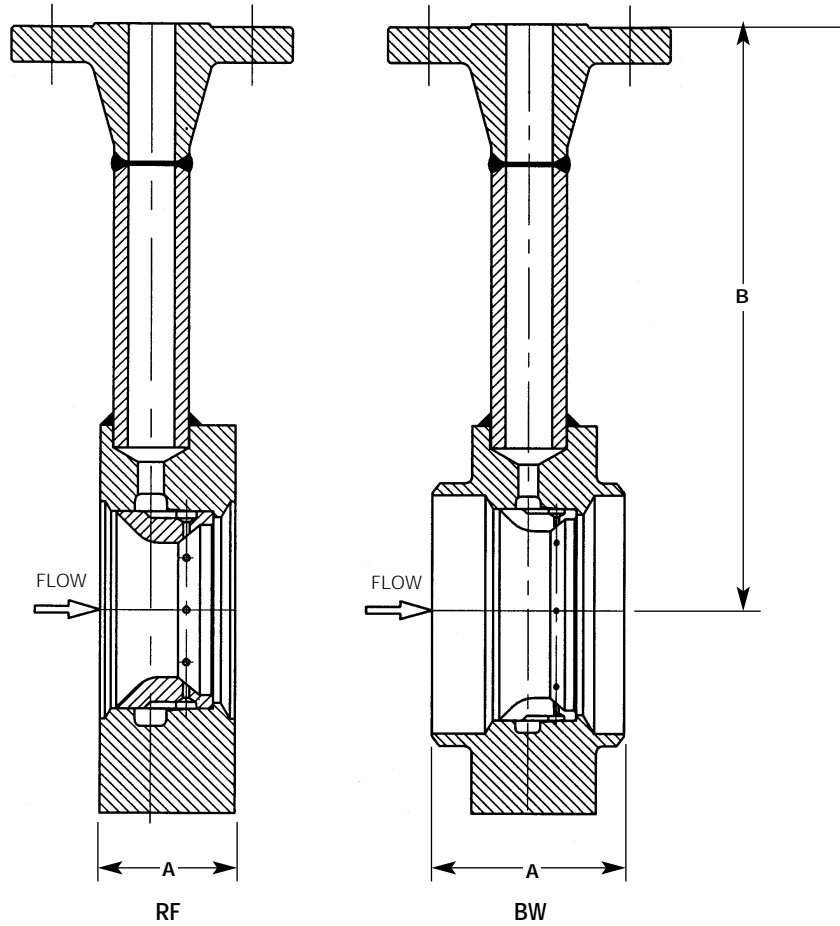

**DIMENSIONS** inches (mm) and **WEIGHTS** pounds (kg)

Size	Weight	Body		Steam Connections	A	B	Water Connections		
		ANSI	DIN				Size	Rating	
								ANSI	DIN
1½ (40)	6.0 (2.7)	Class 150, 300, 600	PN 6, 40, 64, 100	RF (wafer)	1⅞ (40)	7⅞ (200)	1/2 (15)	Class 150, 300 or 600	PN 16, 40, 64, 100
				BW sched. 40	2⅞ (60)	8⅞ (200)	flanged		
				BW sched. 80	2⅞ (60)	8⅞ (200)	RF		
2 (50)	8.2 (3.7)	Class 150, 300, 600	PN 16, 40, 64, 100	RF (wafer)	1⅞ (40)	8⅞ (202)	1/2 (15)	Class 150, 300 or 600	PN 16, 40, 64, 100
				BW sched. 40	2⅞ (65)	9⅞ (202)	flanged		
				BW sched. 80	2⅞ (65)	9⅞ (202)	RF		
3 (80)	15.2 (6.9)	Class 150, 300, 600	PN 16, 40, 64, 100	RF (wafer)	1⅞ (50)	9⅞ (227)	1/2 (15)	Class 150, 300 or 600	PN 16, 40, 64, 100
				BW sched. 40	2⅞ (75)	9⅞ (227)	flanged		
				BW sched. 80	2⅞ (75)	9⅞ (227)	RF		
4 (100)	26.0 (11.8)	Class 150, 300, 600	PN 16, 40, 64, 100	RF (wafer)	2⅞ (60)	10⅞ (260)	1 (25)	Class 150, 300 or 600	PN 16, 40, 64, 100
				BW sched. 40	2⅞ (90)	10⅞ (260)	flanged		
				BW sched. 80	2⅞ (90)	10⅞ (260)	RF		

# VEN-TEMP DESUPERHEATER

## MODEL: 25



### MATERIALS OF CONSTRUCTION

- ASTM SA 105, SA 182 F11 or SA 182 F22
- DIN C22.8, 1.7335 or 1.7380
- Other materials upon request

### APPLICABLE CODES

- ASME / ANSI B16.34 class 150 to 2500
- DIN 2401 class PN 25 to 400
- Butt weld connections to ANSI B16.25 or DIN 2559

### TECHNICAL DATA

- Size: Steam 1½" to 16" (DN40 to DN400)  
Water 1½" to 2" (DN15 to DN50)
- Forged construction
- Venturi nozzle type
- Low pressure loss over the desuperheater station
- Water pressures marginally above steam pressure

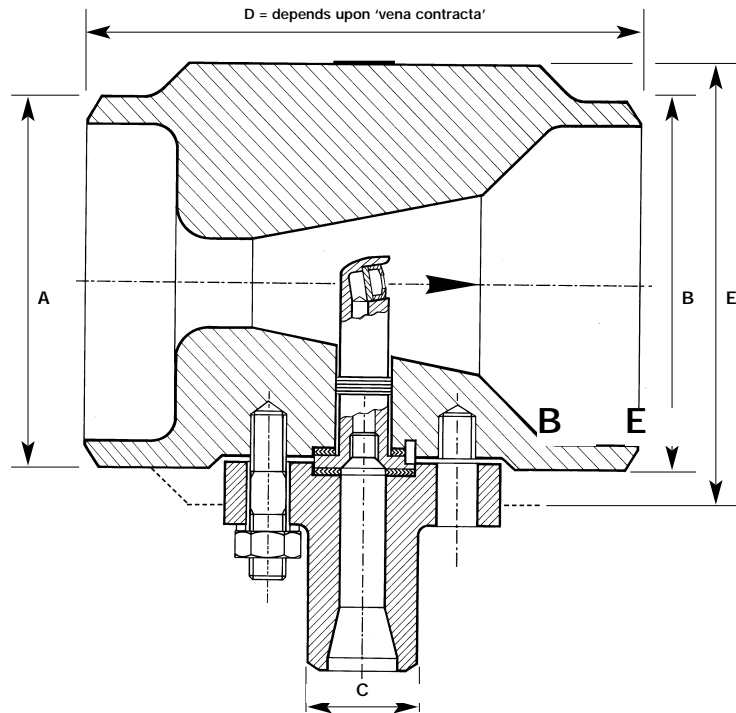

TABLE 2 DIMENSIONS inches (mm)

Connections		Class 150	PN 25/40	Class 300	PN 64	Class 600	PN 100	Class 900	PN 160	Class 1500	PN 250	Class 2500	PN 320
A - B / C	A - B / C	Ø E		Ø E		Ø E		Ø E		Ø E		Ø E	
1½"/½"	DN 40 / 15	127	150	156	170	156	170	178	170	178	185	203	195
2"/½"	DN 50 / 15	152	165	165	180	165	195	216	195	216	200	235	210
3"/1"	DN 80 / 25	190	200	210	215	210	230	241	230	267	255	305	275
4"/1"	DN 100 / 25	229	235	254	250	273	265	292	265	311	300	356	335
6"/1½"	DN 150 / 40	279	300	318	345	356	355	381	355	394	390	483	425
8"/1½"	DN 200 / 40	343	375	381	415	419	430	470	430	483	485	552	525
10"/2"	DN 250 / 50	406	450	445	470	508	505	546	515	584	585	673	640
12"/2"	DN 300 / 50	483	515	521	530	559	585	610	585	673	-	762	-
14"/2"	DN 350 / 50	533	580	584	600	603	655	641	-	749	-	-	-
16"/2"	DN 400 / 50	597	660	648	670	686	-	705	-	829	-	-	-

#### Notes

- Dimensions may be subject to change without prior notification and depending to the standards (flanged - butt weld, etc.)
- Other pressure classes upon request.
- Narvik will provide an order related certified dimensional drawing upon request.

**Definition**

$$K_v = Q \sqrt{\frac{S.G.}{\Delta P}}$$

**Cv (Kv) CAPACITY RANGES**

Size	Standard capacity ranges		
1/2" (16mm)	A	Cv = 0,0125	Kv = 0,0108
	B	Cv = 0,0263	Kv = 0,0227
	C	Cv = 0,0507	Kv = 0,0437
	D	Cv = 0,0973	Kv = 0,0839
	Dx	Cv = 0,1927	Kv = 0,1661
1" (25mm)	E	Cv = 0,3158	Kv = 0,2722
	F	Cv = 0,4720	Kv = 0,4069
	G	Cv = 1,0000	Kv = 0,8621
	H	Cv = 1,5567	Kv = 1,3420
	K	Cv = 2,2233	Kv = 1,9164

Other Cv/Kv values upon request

**Important system parameters**

Apart from the spray quality of the atomizer (primary atomization) there are other system parameters which influence the Desuperheater stations performance. These are:

**Distance to sensor**

The distance from the Ven-Temp Desuperheater to the temperature sensor should be 39 to 50 feet (12 to 15 meters), although the distance specific to the application is advised by Narvik at the enquiry stage. Longer distances will ensure that full evaporation of the water will take place at lower steam velocities.

**Required straight pipe run**

The minimum pipe run, required downstream, varies with each individual application and is specified by Narvik at the enquiry stage. This straight run is needed to prevent erosion due to impingement of water droplets against pipewalls, valves and fittings. Upstream straight run is normally 5 x D and the outlet straight run 13 feet (4 meters), as a minimum.

For applications outside these limitations, consult Narvik or your local representative.

Spray water must be injected in the direction of the steam flow.

Narvik always recommends a strainer with a mesh size of approx. 100 µ in the water supply line to protect the injection nozzle from clogging.

**Ordering / sizing data**

The Ven-Temp Desuperheater works optimally under their design conditions. A minimum differential in static pressure is required to maintain the velocity at such a level that proper mixing of water and steam is achieved.

**Steam Data**

Inlet pressure	psi	(bar)
Inlet temperature	°F	(°C)
Outlet temperature	°F	(°C setpoint )
Steam flow max.	t/hr	
Steam flow normal	t/hr	
Steam flow min.	t/hr	

**Water Data**

Water pressure	psi	(bar)
Water temperature	°F	(°C)

**General**

Pipe size	inch	(mm)
Pipe schedule		

**Turndown ratio**

**Gst max. : Gst min. = 4 : 1**

It is essential not to over-specify the maximum quantity of steam and this rule applies generally to any Desuperheater selection.

**Water / Steam ratio**

**Gst : Gw = 5 : 1**

Above this ratio, proper evaporation of the injection water cannot always be guaranteed.

# LESLIE MODEL SPID

## Desuperheater Specification Form

LINEAR

**LESLIE**  
CONTROLS, INC.  
A Division of CIRCOR International, Inc.  
12501 Telecom Drive · Tampa, Florida 33637  
(813) 978-1000 · FAX: (813)-978-0984

**CONTROL VALVE  
SPEC SHEET**

Project/Job \_\_\_\_\_  
 Unit/Customer \_\_\_\_\_  
 P.O./LCO File # \_\_\_\_\_  
 Item \_\_\_\_\_  
 Contract \_\_\_\_\_  
 MFR Serial# \_\_\_\_\_

Data Sheet \_\_\_\_\_ of \_\_\_\_\_  
 Spec \_\_\_\_\_  
 Tag \_\_\_\_\_  
 Dwg \_\_\_\_\_  
 Service \_\_\_\_\_

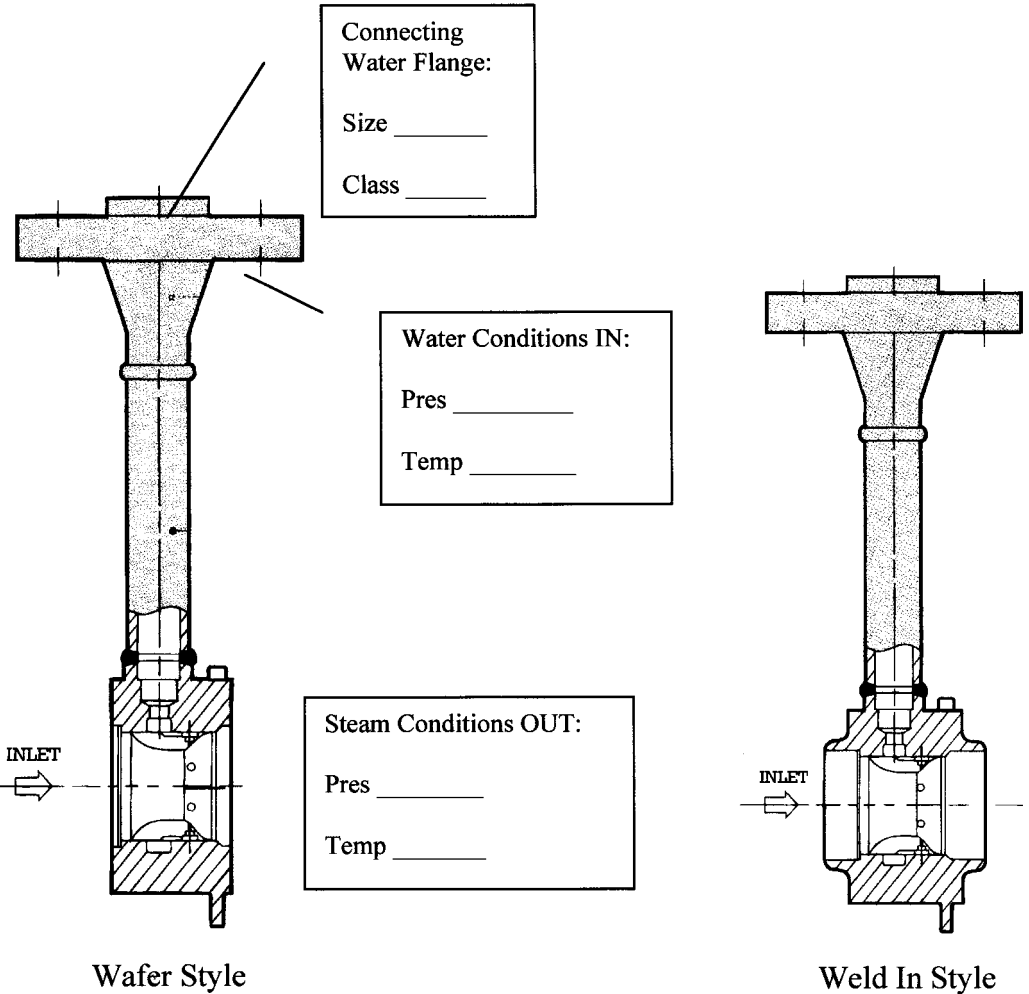

For use in small steam lines with minimal steam pressure losses. Steam control within 43°F of saturation temp and +/- 1% of controller range. Water flange connection available 1/2" - 1" size. Steam connection available in wafer or butt weld in 1 1/2" - 4" size.

**Distance to Sensor:** distance from injection point to temp sensor should be 40-50 ft. Systems operating at pressures above 362psi can have significantly less run to the sensor (consult factory).

**Required Straight Pipe Run:** upstream straight pipe run is normally 6xD and the downstream straight pipe run 20xD, as a minimum. For other distance applications consult factory.

**Turndown ratio:** normally 1:40. Ratio is determined by dividing "steam flow max" x "steam flow min".

QUESTIONS? CALL LESLIE CONTROLS @ (813) 978-1000 PLEASE FAX COMPLETED FORM TO: (813) 977-0174

# LESLIE MODEL QT

## Steam Conditioning System Specification Form

**LESLIE CONTROLS, INC.**  
 A Division of CIRCOR International, Inc.  
 12501 Telecom Drive · Tampa, Florida 33637  
 (813) 978-1000 · FAX: (813)-978-0984

**CONTROL VALVE SPEC SHEET**

Project/Job _____	Data Sheet _____ of _____
Unit/Customer _____	Spec _____
P.O./LCO File # _____	Tag _____
Item _____	Dwg _____
Contract _____	Service _____
MFR Serial# _____	

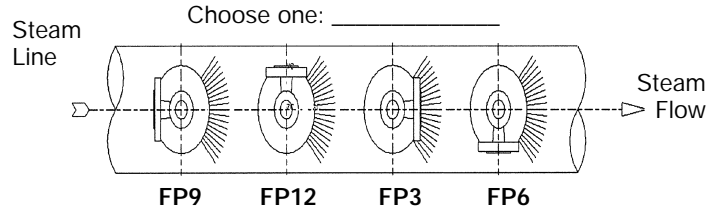
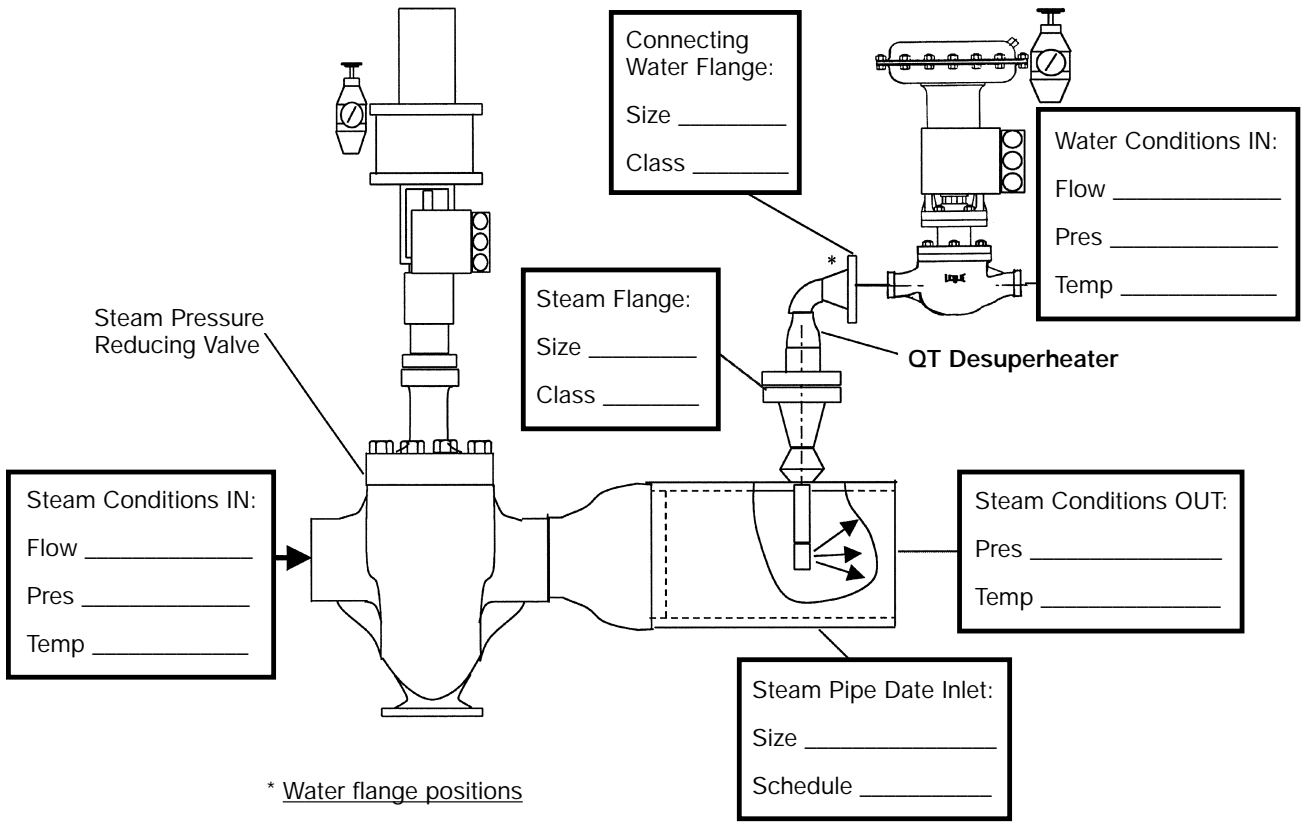

*Note: Spraywater must be injected in the direction of the steam flow. Select appropriate spray head flange position.*

**Distance Sensor:**  
 distance from injection point to temp sensor should be 40-50 ft. Systems operating at pressures above 362 psi can have significantly less run to the sensor (consult factory).

**Required Straight Pipe Run:**  
 distance from injection point to first pipe bend is also a function of steam pressure, temp and nozzle size. Based on experience systems up to 362 psi, 13-20 ft., is an acceptable distance.

**Turndown ratio:**  
 normally 18:1 and 27:1. Ratio is determined by dividing "steam flow max" x "Steam flow min".

**QUESTIONS? CALL LESLIE CONTROLS @ (813) 978-1000 PLEASE FAX COMPLETED FORM TO: (813) 977-0174**

# LESLIE MODEL AT

## Steam Conditioning System Specification Form

LINEAR

**LESLIE CONTROLS, INC.**  
 A Division of CIRCOR International, Inc.  
 12501 Telecom Drive · Tampa, Florida 33637  
 (813) 978-1000 · FAX: (813)-978-0984

**CONTROL VALVE SPEC SHEET**

Project/Job _____	Data Sheet _____ of _____
Unit/Customer _____	Spec _____
P.O./LCO File # _____	Tag _____
Item _____	Dwg _____
Contract _____	Service _____
MFR Serial# _____	

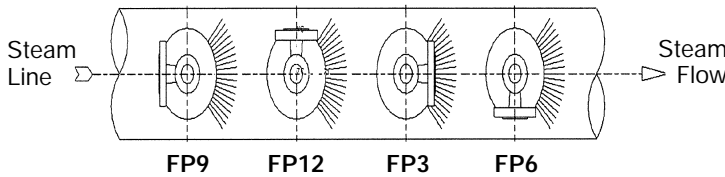
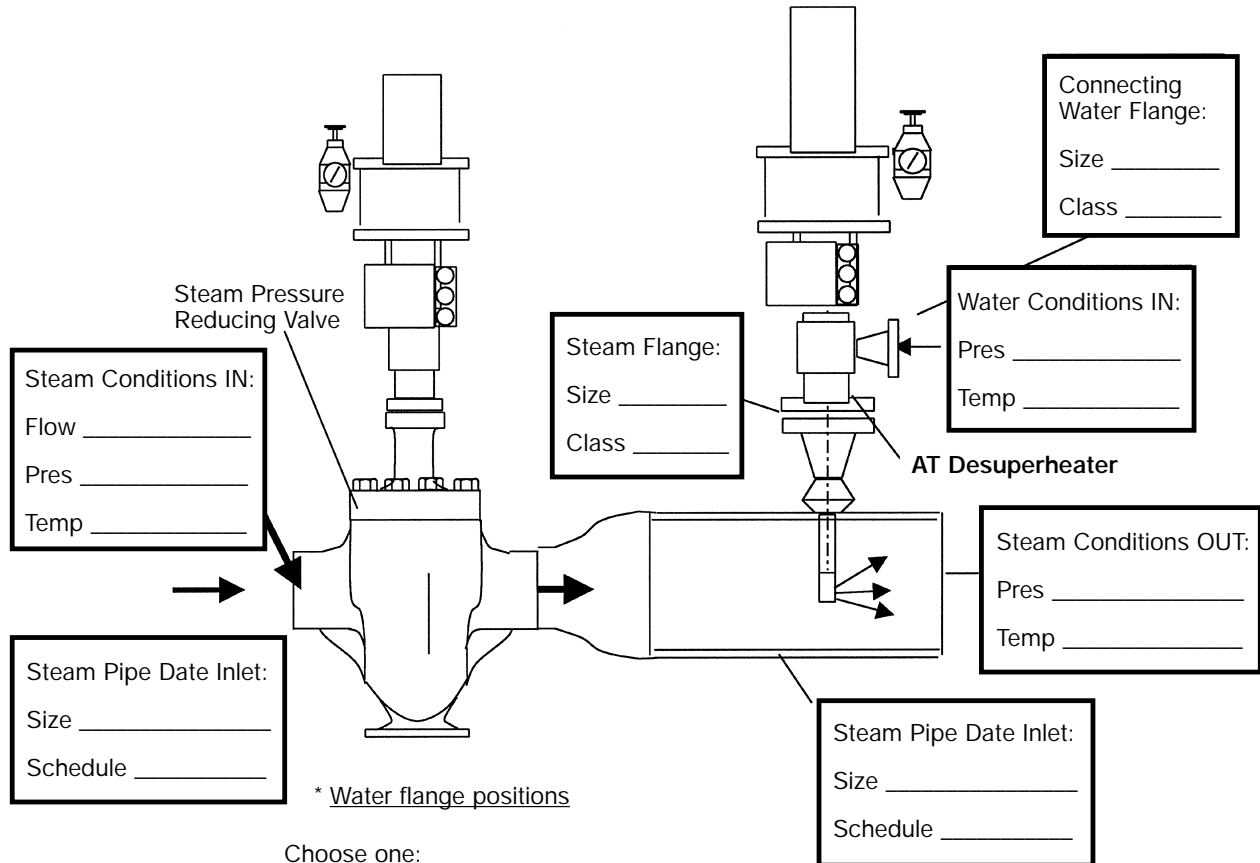

*Note: Spraywater must be injected in the direction of the steam flow. Select appropriate spray head flange position.*

Use on medium/low pressure steam applications. there is no water control valve. The AT desuperheater valve regulates the amount of injection water by varying the number of injection nozzles. This enables the water pressure to remain constant, independent of the number of injection nozzles in operation.

**Distance Sensor:**  
 distance from injection point to temp sensor should be 40-50 ft. Systems operating at pressures above 362 psi can have significantly less run to the sensor (consult factory).

**Required Straight Pipe Run:**  
 distance from injection point to first pipe bend is also a function of steam pressure, temp and nozzle size. Based on experience systems up to 362 psi, 13-20 ft., is an acceptable distance.

**Turndown ratio:**  
 normally 18:1 and 27:1. Ratio is determined by dividing "steam flow max" x "Steam flow min".

QUESTIONS? CALL LESLIE CONTROLS @ (813) 978-1000 PLEASE FAX COMPLETED FORM TO: (813) 977-0174