



## ABB TZID-C POSITIONER

### APPLICATION DATA

- Split range parallel stations
- Where precise positioning is required
- Building management or PLC input

### OPTIONS

- EX-Protection EEx ib II C T6
- Plug In Modules
  - Analog Position Feedback Signal
  - Digital Position Feedback Signal for Min/Max Position
  - Safety Shutdown Module
- Kit for:
  - Mechanical Position Indicator
  - Digital Position Feedback for Min/Max position for 2-slot type indicators or micro-switch

# ABB TZID-C INTELLIGENT POSITIONER

- **Input Signal** 4-20mA, 2 wire fieldbus connection
- **Supply Air** 20-90 psi (1.4-6 bar)
- **Control Accuracy**  $\leq 0.5\%$
- **Ambient Temp** - 22°F to 185°F  
- 30°C to 85°C
- **Housing** Aluminum coated IP65
- **Vibration Immunity** 10g to 20...80Hz
- **Burden Voltage** 8, 7 V DC (Non Exhaust)

# ABB TZID-C INTELLIGENT POSITIONER

## SPECIFICATION

### Overview

The positioner shall be an electronically-configurable positioner with Hart communication. Positioner shall be suitable for mounting to pneumatic linear or rotary actuators. Positioner shall feature a small and compact design, a modular construction, loop-powered CPU, and an excellent cost/performance ratio.

### Operation

The positioner shall utilize a built-in operating panel providing a 2-line LCD and 4 pushbuttons for local configuration, commissioning and operational monitoring.

### Operating Modes

The positioner shall provide three different operating modes: fixed control; adaptive control; and manual.

### Adaptive Mode

The positioner shall incorporate a unique "Adaptive Control" mode that will "self-tune" positioner control parameters for any valve-actuator combination while controlling the process.

### Pneumatics

Positioner shall utilize an I/P module with subsequent pneumatic amplifier that is used to control the pneumatic actuator. Positioner shall have steady-state air consumption < 0.015 scfm (< 0.03 kg/hr), independent of supply pressure.

### Choice of Fail function

Positioner shall provide either "fail-safe" or "fail-freeze" function via i/p construction.

### Inputs and outputs

The positioner shall have as standard a digital input and a digital output, both of which are in addition to its 4-20 mA input for the analog position set point.

### Modular design

The positioner shall have available optional modules for analog position feedback, digital position feedback, an emergency shutdown module, proximity switches, or 24 V microswitches.

### Single-button commissioning

The positioner shall utilize a commissioning function called Autoadjust which quickly establishes zero, span, and optimum positioning control parameters. Autoadjust function shall start with single pushbutton.

### Display

The positioner shall utilize a 2-line LCD to show % position during operation and also displays via pushbutton operation the following positioner data:  
 Up arrow button: Current setpoint (mA)  
 Down arrow button: Internal device temperature  
 Up + Down arrow buttons: % difference between position and signal

### Mounting

The positioner case shall have one mounting footprint and the positioner design shall utilize one type feedback shaft. The positioner shall easily mount to any linear or rotary valve.

### Positioner shall have the following performance specifications:

#### Accuracy:

≤ 0.5 % of span

#### Tolerance band:

0.3...10 %, adjustable

#### Resolution (A/D conversion):

> 4000 steps

#### Sample rate:

20 msec

### Positioner shall have the following environmental specifications:

#### Influence of ambient temperature:

≤ 0.5 % for every 10°C change in temperature

#### Influence of vibration:

≤ ± 1 % up to 10 g and 20...80 Hz

#### Seismic requirements:

Meets requirements of DIN/IEC 68-3-3 Class III for strong and strongest earthquakes

#### Influence of mounting orientation:

Can be mounted in any position

#### Meets requirements of following directives:

EMC Directive 89/336/EEC as of May 1989

#### EC Directive for CE conformity marking

#### Ambient temperature:

-40 °F to +185 °F (-40 °C to +85 °C) for operation, storage and transport;

#### Relative humidity:

Operational (with closed housing and air supply switched on): < 95 % (annual average), condensation permissible

#### Transport and storage:

75 % (annual average), non-condensing

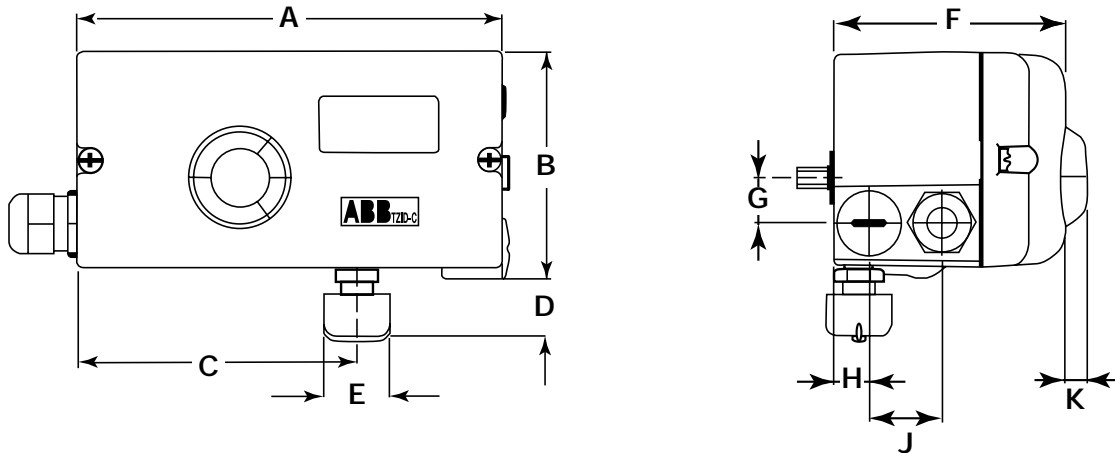

**DIMENSIONS<sup>1</sup>** inches (mm) **AND WEIGHTS** pounds (kg)

A	B	C	D	E	F	G	H	J	K	WEIGHT
6½ (168.5)	3½ (89.5)	4¾ (110.75)	1 (25)	1 (ø26)	3.62 (92)	¾ (18)	½ (14)	1½ (29)	¾ (9)	5 (796)



ABB AV SERIES POSITIONER

#### APPLICATION DATA

- Split range parallel stations
- Where precise positioning is required
- Building management or PLC input

## ABB AV SERIES POSITIONER

- **Input Signal** 4-20mA, 2 wire fieldbus connection
- **Control Accuracy**  $\leq 0.5\%$  of span
- **Supply & Exhaust Air Capacity** up to 23 scfm at 70psi supply pressure
- **Ambient Temp** - 40°F (- 40°C) to 185°F (85°C)
- **Housing** is epoxy coated cast aluminum for long life and environmental protection
- **Vibration Immunity** 15 to 120 Hz at accelerations to 2 G
- **Burden Voltage** 8, 7 V DC (Non Exhaust)
- **Mounting** in any position to any linear or rotary valve
- **Autoadjusts** to control parameters with single pushbutton
- **Adaptive Mode** will self-tune positioner control parameters for any valve-actuator combination while controlling process
- **Cam provides application flexibility** between input signal and actuator position and includes direct and reverse acting
- **Threaded Exhaust Vent** allows use of natural gas

# ABB AV SERIES POSITIONER

## SPECIFICATION

### Overview

The positioner shall be an electronically-configurable positioner with Hart communication. Positioner shall be suitable for mounting to pneumatic linear or rotary actuators. Positioner shall feature a small and compact design, a modular construction, loop-powered CPU, and an excellent cost/performance ratio.

### Operation

The positioner shall utilize a built-in operating panel providing a 2-line LCD and 4 pushbuttons for local configuration, commissioning and operational monitoring.

### Operating Modes

The positioner shall provide three different operating modes: fixed control; adaptive control; and manual.

### Adaptive Mode

The positioner shall incorporate a unique "Adaptive Control" mode that will "self-tune" positioner control parameters for any valve-actuator combination while controlling the process.

### Pneumatics

Positioner shall utilize an I/P module with subsequent pneumatic amplifier that is used to control the pneumatic actuator. Positioner shall have steady-state air consumption < 0.015 scfm (< 0.03 kg/hr), independent of supply pressure.

### Choice of Fail function

Positioner shall provide either "fail-safe" or "fail-freeze" function via i/p construction.

### Inputs and outputs

The positioner shall have as standard a digital input and a digital output, both of which are in addition to its 4-20 mA input for the analog position set point.

### Modular design

The positioner shall have available optional modules for analog position feedback, digital position feedback, an emergency shutdown module, proximity switches, or 24 V microswitches.

### Single-button commissioning

The positioner shall utilize a commissioning function called Autoadjust which quickly establishes zero, span, and optimum positioning control parameters. Autoadjust function shall start with single pushbutton.

### Display

The positioner shall utilize a 2-line LCD to show % position during operation and also displays via pushbutton operation the following positioner data:

Up arrow button: Current setpoint (mA)

Down arrow button: Internal device temperature

Up + Down arrow buttons: % difference between position and signal

### Mounting

The positioner case shall have one mounting footprint and the positioner design shall utilize one type feedback shaft. The positioner shall easily mount to any linear or rotary valve.

### Positioner shall have the following performance specifications:

**Accuracy:** ≤ 0.5 % of span

**Tolerance band:** 0.3...10 %, adjustable

**Resolution (A/D conversion):** > 4000 steps

**Sample rate:** 20 msec

### Positioner shall have the following environmental specifications:

**Influence of ambient temperature:** ≤ 0.5 % for every 10 °C change in temperature

**Influence of vibration:** ≤ ± 1 % up to 10 g and 20...80 Hz

**Seismic requirements:** Meets requirements of DIN/IEC 68-3-3 Class III for strong and strongest earthquakes

**Influence of mounting orientation:** Can be mounted in any position

**Meets the requirements of the following directives:** EMC Directive 89/336/EEC as of May 1989

EC Directive for CE conformity marking

**Ambient temperature:** -40 °F to +185 °F (-40 °C to +85 °C) for operation, storage and transport;

**Relative humidity:**

Operational (with closed housing and air supply switched on): < 95 % (annual average), condensation permissible

**Transport and storage:** 75 % (annual average), non-condensing

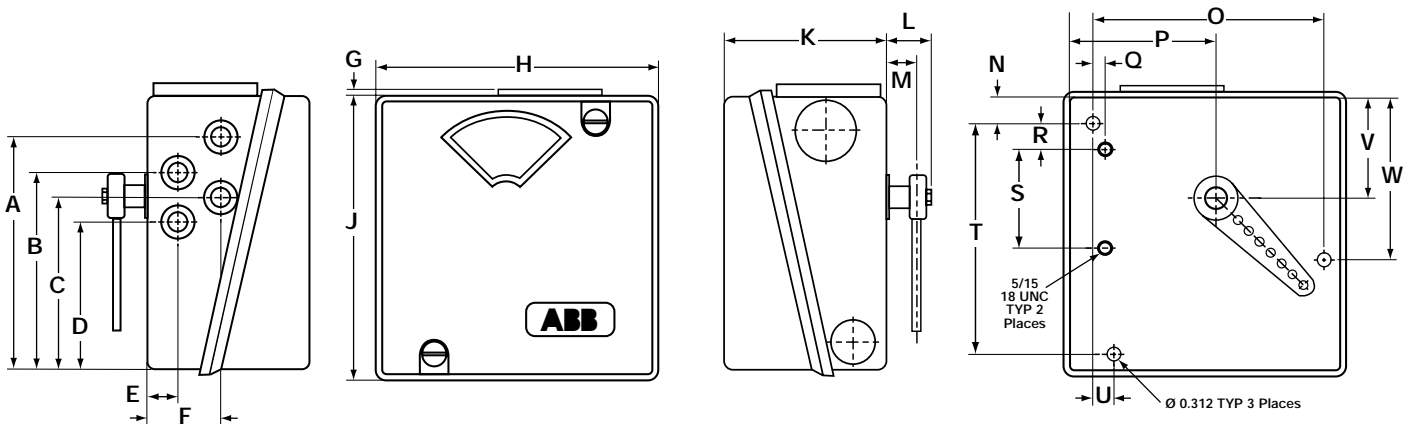

**DIMENSIONS** inches (mm) and **WEIGHT** pounds (kg)

A	B	C	D	E	F	G	H	J	K	L	M	N	O	P	Q	R	S	T	U	V	W	Wgt.
1¼	4½	3⅞	3⅝	1⅞	1⅞	⅝	6⅞	6½	3⅞	1½	1⅞	1⅞	5¼	3⅞	¼	1⅞	2¼	5¼	½	2⅞	3⅞	10
(134.0)	(113.4)	(98.9)	(84.7)	(17.5)	(42.4)	(3.6)	(163.3)	(164.8)	(93.7)	(26.2)	(17.5)	(15.2)	(133.6)	(84.8)	(7.1)	(15.0)	(57.2)	(133.4)	(12.2)	(58.2)	(94.0)	(4.54)