

<b>TRANSMATION</b> Products Group	334A Field Calibration Procedure	DOCUMENT NO.	REV.
		100903-972	A
Created by: Doug Neff		Date: 30Nov99	Sheet 1 of 7

Rev	Date	Appd	DCN								
A	27JAN00		10759								

**Suggested Equipment:**

1. Precision Voltmeter with accuracy of  $\pm 0.023\%$  of reading at 5V.
2. 250 $\Omega$  Standard with accuracy and stability of  $\pm 0.01\%$  between 18°C and 28°C
3. Precision Current Source with accuracy of  $\pm 0.018\%$  of setting at 50mA and  $\pm 0.025\%$  of setting at 20mA.
4. Precision DC Voltage Source with accuracy of  $\pm 0.016\%$  of setting at 95V.

**ENABLING CALIBRATION:**

Remove the four corner screws. While holding the UUT face down in one hand, carefully separate the top and bottom housing. Place the unit into Calibration mode by shorting the header (JP1) located on the lower right side of the main circuit board (See Figure 1) while turning the UUT on. The BAT indicator will flash to indicate the UUT is in calibration mode. Verify that the UUT is in Calibration mode by observing that the BAT indicator is flashing. Place fresh batteries into the UUT before any calibration adjustments are made.

**CALIBRATION:** (See Figure 1 for all pot locations)

**SOURCE mA:**

1. Connect the UUT to the DMM and 250 $\Omega$  standard as shown in Figure 2.
2. Turn the UUT on, and set the UUT to source mA mode with calibration enabled:  
 Power Switch - mA (remember to short JP1; see enabling calibration)  
 Mode Switch - Source  
 Quik-Chek Switch - 20.00mA
3. Dial the UUT so the display reads 20.00mA. NOTE: there is normally three clicks of the digi-pot before the display changes its reading. Set the digi-pot to the middle (or second) click. Adjust R16 so the DMM reads 5.0000V  $\pm$  0.0011V.
4. Set the Quik-Chek Switch to 4.00mA  
 Dial the UUT so the DMM reads 1.0000V  $\pm$  0.0007V.  
 Set the Quik-Chek Switch to Adjust (center position) to save the calibration settings.

<b>TRANSMATION</b> Products Group	334A Field Calibration Procedure	DOCUMENT NO. 100903-972	REV. A
	Created by: Doug Neff	Date: 30Nov99	Sheet 2 of 7

**SOURCE %:**

1. Turn the UUT off to disable calibration.
  
2. Turn the UUT on, and set the UUT to source % mode:  
 Power Switch - % 4 to 20mA  
 Mode Switch - Source  
 Quik-Chek Switch - 100.0%
  
3. Adjust R29 so the UUT displays 100.0% ± 0.0%  
 Verify that the DMM reads 5.0000V ± 0.0011V
  
4. Set the Quik-Chek Switch to Adjust (center position)  
 Dial the UUT so the DMM reads 0.0000V ± 0.0006V.  
 Adjust R8 so the UUT displays -25.0% ± 0.0%

**NOTE:** Pots R29 and R8 are interactive. Therefore, repeat steps 3 and 4 as necessary to obtain the desired accuracy.

5. Set the Quik-Chek Switch to 0.0%, and verify the UUT displays 0.0% ± 0.0% and that the DMM reads 1.0000V ± 0.0007V.

**READ VDC:**

1. Connect the UUT to the Precision DC Voltage Source as shown in Figure 3.
  
2. Turn the UUT on, and set the UUT to read VDC mode:  
 Power Switch - Read VDC  
 Mode Switch - Read  
 Quik-Chek Switch - 100.0%
  
3. Set the DC Voltage Source to 95.000V.  
 Adjust R48 so that the LCD displays 95.00V.

<b>TRANSMATION</b> Products Group	334A Field Calibration Procedure	DOCUMENT NO. 100903-972	REV. A
	Created by: Doug Neff	Date: 30Nov99	Sheet 3 of 7

## FUNCTIONAL CHECK

### Source Mode Check

1. Connect the UUT to the DMM and 250Ω standard as shown in Figure 2.
2. Turn the UUT on, and set the UUT to source mA mode.  
 Power Switch - mA  
 Mode Switch - Source
3. Verify the Quik-Chek outputs are in spec:

Setting	Spec
4.00mA	1.0000V ± 0.0029V
20.00mA	5.0000V ± 0.0045V

### Read Mode Check

1. Connect the UUT to the Current Source as shown in Figure 4.
2. Turn the UUT on, and set the UUT to Read mA mode:  
 Power Switch - mA  
 Mode Switch - Read  
 Quik-Chek Switch - N/A
3. Set the Current Source to the following values, and check that the UUT is within specification according to the following table:

Current Source Setting	UUT Display mA	Tolerance
4mA	4.00mA	±0.01mA
8mA	8.00mA	±0.01mA
12mA	12.00mA	±0.02mA
16mA	16.00mA	±0.02mA
20mA	20.00mA	±0.02mA
50mA	50.00mA	±0.04mA

### 2-Wire Check

1. Connect the UUT as shown in Figure 5.
2. Turn the UUT on, and set the UUT to Read 2-Wire mode:  
 Power Switch - mA  
 Mode Switch - 2 Wire  
 Quik-Chek Switch - 20.00mA

<b>TRANSMATION</b> Products Group	334A Field Calibration Procedure	DOCUMENT NO. 100903-972	REV. A
	Created by: Doug Neff	Date: 30Nov99	Sheet 4 of 7

3. Verify that:  
 The UUT displays  $20.00\text{mA} \pm 0.02\text{mA}$   
 The DMM reads  $5.0000\text{V} \pm 0.0045\text{V}$
4. Set the Quik-Chek Switch to  $4.00\text{mA}$  and verify that:  
 The UUT displays  $4.00\text{mA} \pm 0.01\text{mA}$   
 The DMM reads  $1.0000\text{V} \pm 0.0029\text{V}$
5. Set the Power Switch to % and verify that:  
 The UUT displays  $00.0\% \pm 0.1\%$   
 The DMM reads  $1.0000\text{V} \pm 0.0029\text{V}$
6. Set the QuiK-Chek Switch to  $100.0\%$  and verify that:  
 The UUT displays  $100.0\% \pm 0.1\%$   
 The DMM reads  $5.0000\text{V} \pm 0.0045\text{V}$

**Read VDC Check**

1. Connect the UUT to a Voltage Source as shown in Figure 3.
2. Set the voltage source to the following values, and check that the UUT is within specification according to the following table:

Voltage	Tolerance
70V	$\pm 0.06\text{V}$
50V	$\pm 0.06\text{V}$
20V	$\pm 0.06\text{V}$
5V	$\pm 0.06\text{V}$

This completes the calibration procedure.

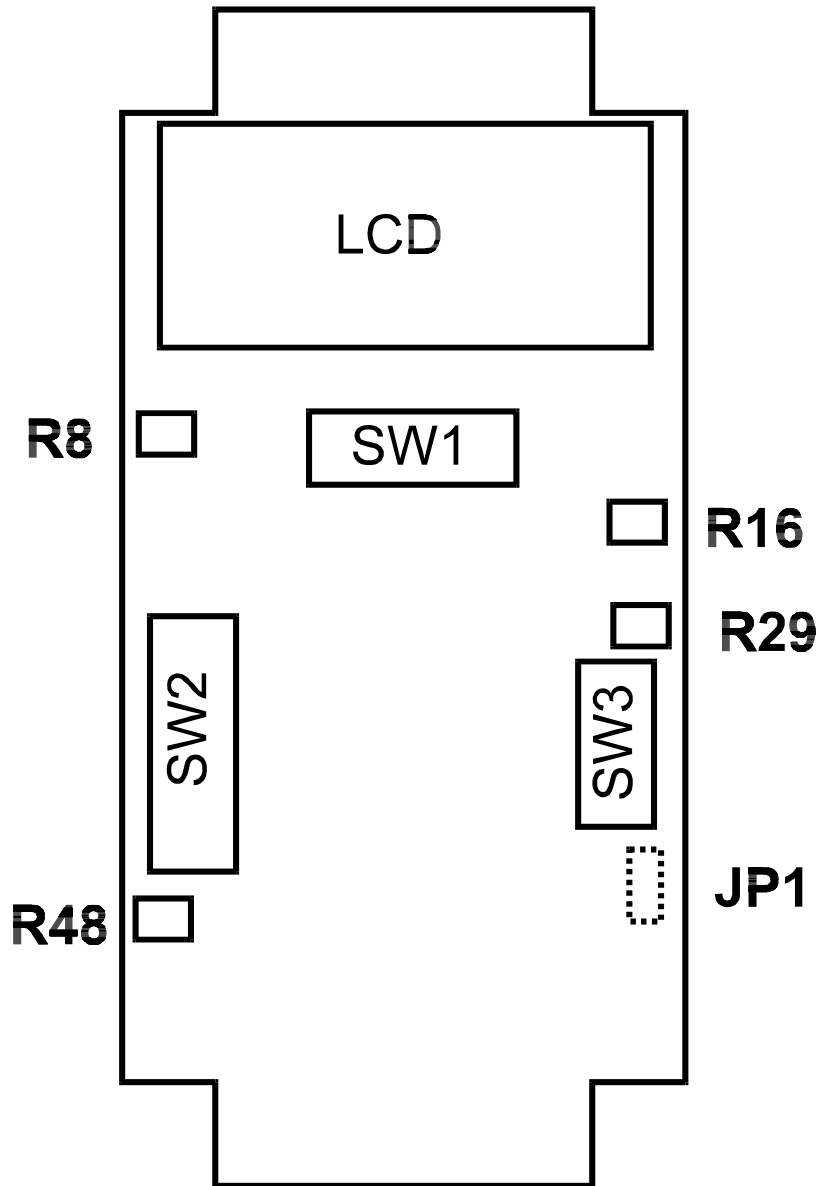

FIGURE 1

<b>TRANSMATION</b> Products Group	334A Field Calibration Procedure	DOCUMENT NO. 100903-972	REV. A
	Created by: Doug Neff	Date: 30Nov99	Sheet 6 of 7

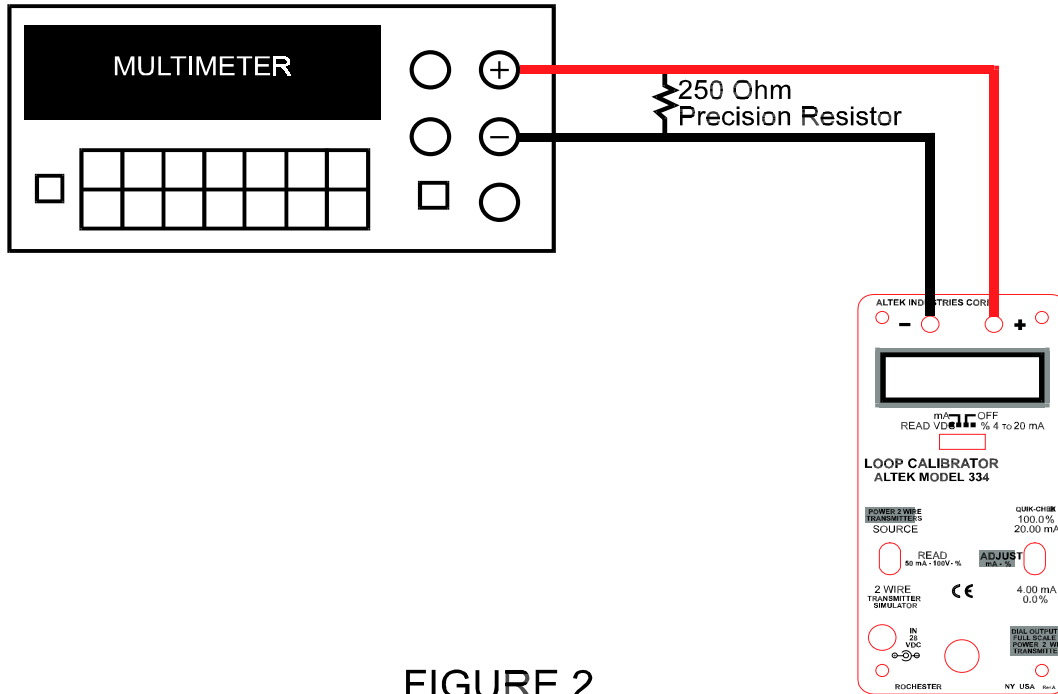

FIGURE 2

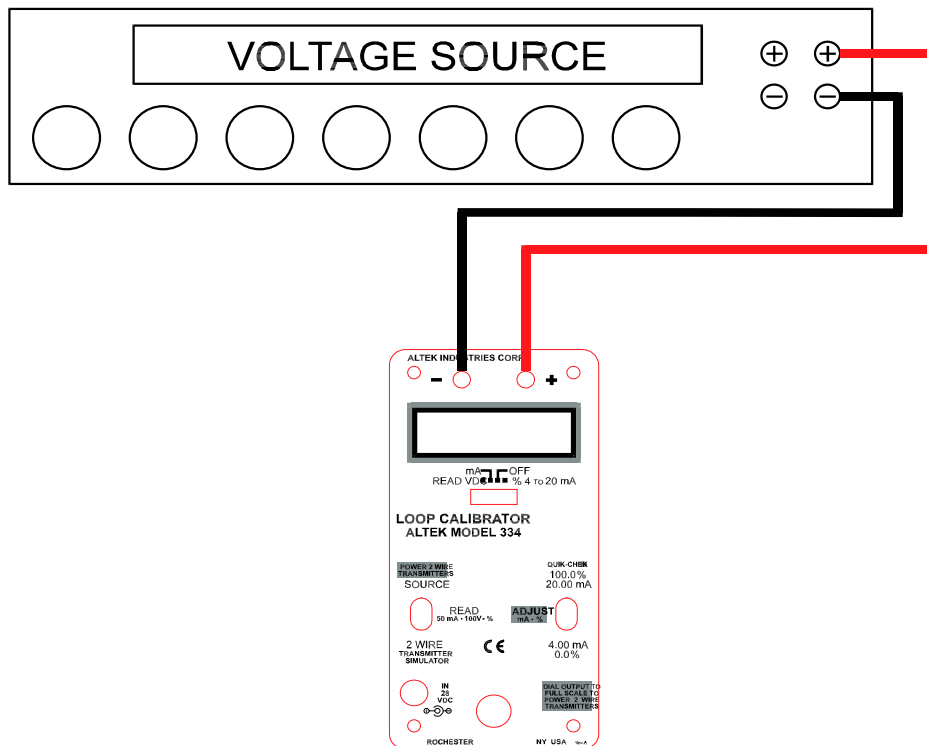

FIGURE 3

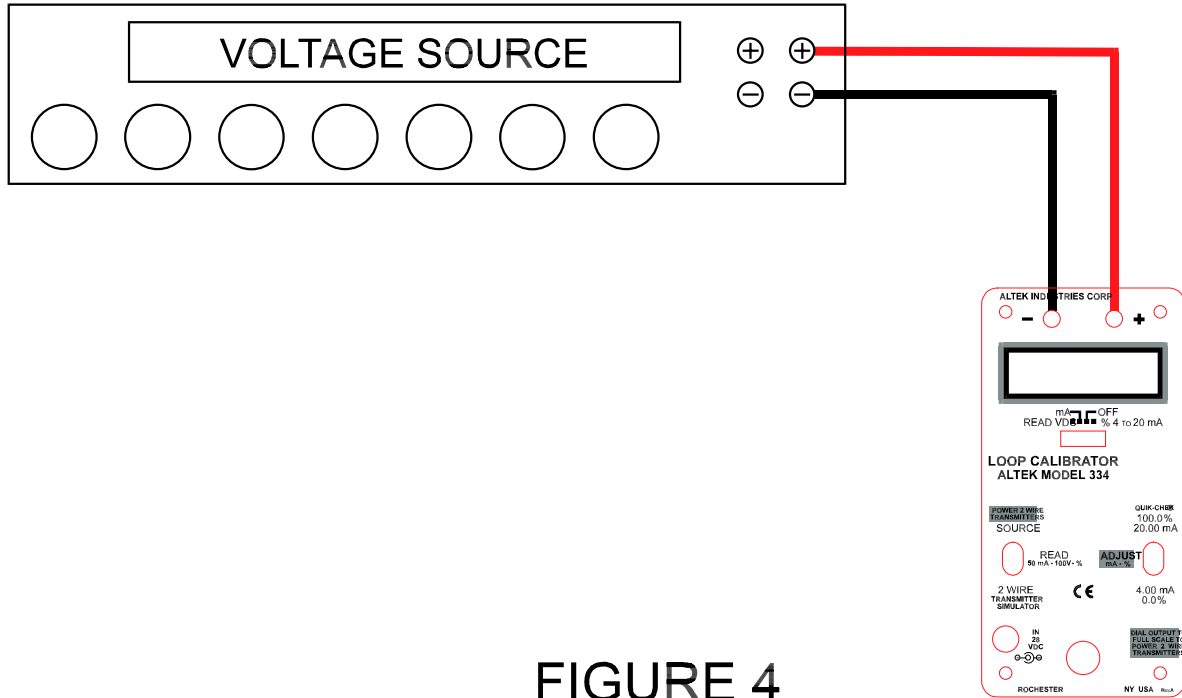

FIGURE 4

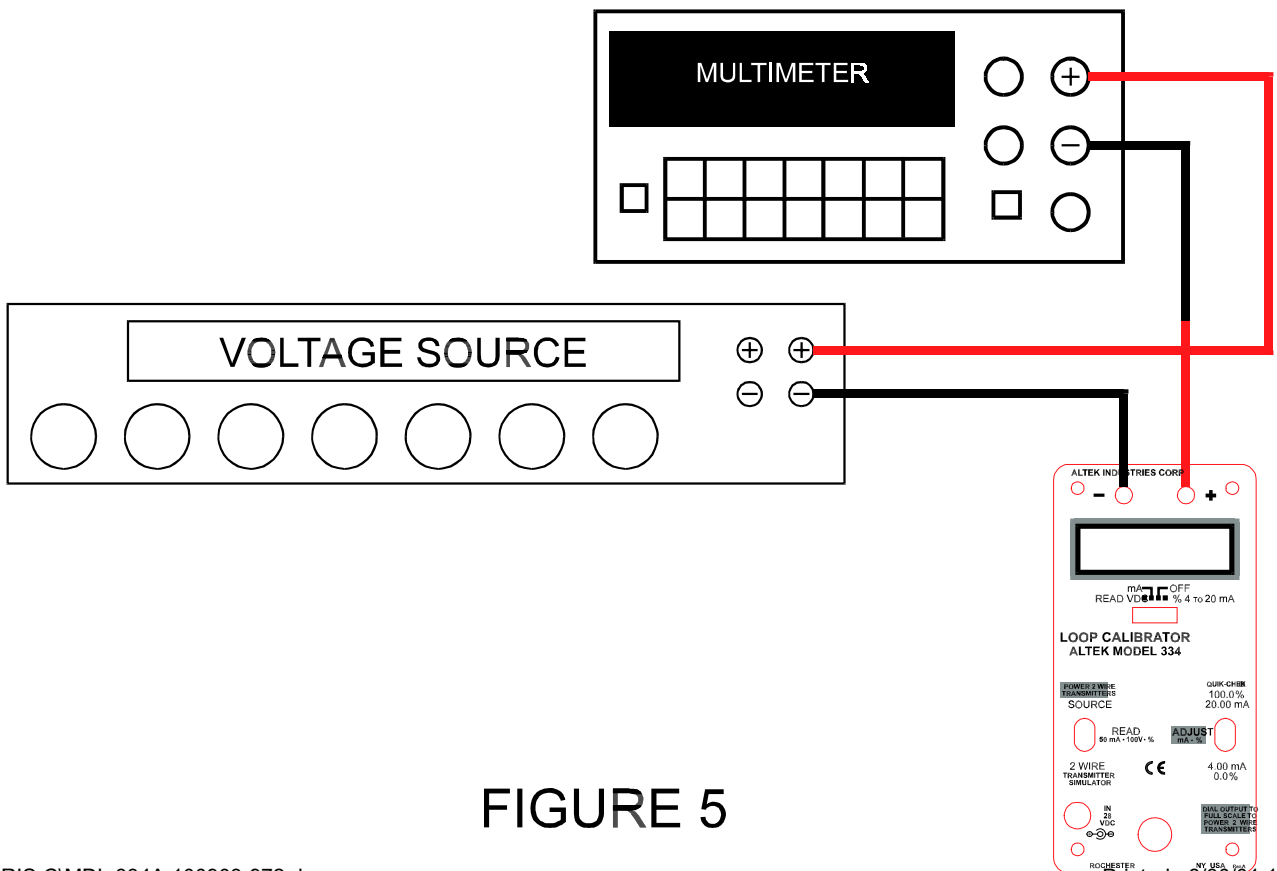

FIGURE 5