	Model 211 Field Calibration Procedure	DOCUMENT NO. 1-552	REV. D
	Created by: T.Tetreault	Date:14jul 92	PAGE 1 OF 5

Rev	Date	Appd	DCN								
B	7/14/92	RPC	---								
C	11/26/96	RPC	---								
D	26SEP00	TJT	10394								

Suggested Equipment:

- 1) 5 digit ohm meter, capable of 4-wire measurements. (Accuracy $\pm 0.005\%$ of reading or better, with an excitation current of 1.00 mA at 2000.0 ohms).
- 2) Decade box. Read resistance's with a 5 digit ohm meter (4-wire mode) and record the following values on a copy of *Table 1*. (1900.0 Ω , 400.0 Ω and 100.0 Ω)

Note: The HP 3458A & HP 34401A multimeters are incompatible with this procedure. They automatically change the excitation current used to read resistance at 1000 ohms.

Precautions:

- 1) Please observe anti-static procedures.
- 2) Avoid touching the connections, to limit errors in calibration.
- 3) Before any adjustments to the model 211 are made, remove the four corner screws and install a fresh 9-volt battery.

Note:

There are two different calibration procedures used to calibrate the model 211. One is for **REV_** and **REV A** boards, and the other is for **REV B** boards and above. To determine the REV you must remove the four corner screws from the model 211 and lift the 211 out of the box. Turn the unit upside down. On the lower right-hand corner of the bottom PC board is the number 39021. The revision code is to the right of that number. If the unit is **REV_** or **REV A**, use the calibration procedure on page 2. If the unit is **REV B** (or greater) then use the calibration procedure on page 3.

Distributed by: M&M Control Service, INC. 800-876-0036
[Http://www.mmcontrol.com](http://www.mmcontrol.com) Email: Sales@mmcontrol.com

	Model 211 Field Calibration Procedure	DOCUMENT NO. 1-552	REV. D
	Created by: T.Tetreault	Date:14jul 92	PAGE 1 OF 5

Calibration Procedure for (REV_ or REV A)

Turn the unit on and record the ALPHA # 1.xxxx (i.e., 1.3850) which appears on the display on a copy of *Table 1*. Turn the unit off and record the position of the DIP switches on the same table.

Simulate Mode - To start calibration, place DIP switches 1 through 4 in the up position and install the optional wire into the 4 wire jack. The unit is now in a special test/calibrate mode.

- a) Turn unit on to **simulate** and press the STORE / RESET push-button to scroll unit until the **OHM** symbol is displayed on the LCD.
- b) Connect the 5 digit ohm meter to the leads of the 211 in 4-wire configuration. (See *Diagram 1*)
- c) Dial the 211 until the LCD displays 400.00 ohms, then place switches 1 and 2 of the DIP switch in the down position and allow the unit to settle for approximately 10 seconds.
- d) Adjust pot R108 (see *Diagram 2*) until the **OHMMETER READS THE SAME AS THE 211**. **Adjustment Tolerance:** ± 0.02 ohms.
Note: Allow 10 seconds for both the ohmmeter and the 211 to settle after each adjustment.
- e) Place DIP switch position 1 in the up position and dial the 211 to display 471.0 ohms, then place DIP switch 1 down and allow unit to settle for approximately 10 seconds.
- f) Adjust pot R117 (see *Diagram 2*) until the **211 DISPLAYS THE SAME AS THE OHMMETER**. **Adjustment Tolerance:** ± 0.1 ohms.
- g) Place switches 1 and 2 of the DIP switch in the up position.
- h) Dial the 211 to between 10 and 12 random settings including 0.00, 400.00 and 473.0 ohms. Make sure the unit is within ± 0.07 ohms in the 000.00 ohms scale and ± 0.4 ohms in the 000.0 ohms scale.

Read Mode - Turn the 211 on in read mode. Allow 60 seconds for the unit to settle.

- a) Connect the decade box to the 211 using the 4-wire configuration. (see *Diagram 3*).
- b) Dial the decade box to 100, 400, 2000 ohms respectively. Allow the 211 approximately 10 seconds to settle between each setting. Compare the 211 readings to the previously recorded values in Table 1. **Tolerance:** ± 0.07 ohms in the 000.00 ohms scale and ± 0.4 ohms in the 000.0 ohms scale. Check several random resistance values to verify the unit is in spec.

	Model 211 Field Calibration Procedure	DOCUMENT NO. 1-552	REV. D
	Created by: T.Tetreault	Date:14jul 92	PAGE 1 OF 5

Calibration Procedure for (REV B or Greater)

Turn the unit on and record the ALPHA # 1.xxxx (i.e., 1.3850) which appears on the display on a copy of *Table 1*. Turn the unit off and record the position of the DIP switches on the same table.

Simulate Mode - To start calibration, place DIP switches 1 through 4 in the up position (if your 211 has five DIP switches, place DIP 5 in the down position) and install the optional wire into the 4 wire jack. The unit is now in a special test/calibrate mode.

- a) Turn unit on to **simulate** and press the STORE / RESET push-button to scroll unit until the **OHM** symbol is displayed on the LCD.
- b) Connect the ohm meter to the leads of the 211 in 4-wire configuration. (*See Diagram 1*)
- c) Dial the 211 until the LCD displays 400.00 ohms, and wait for "SIM" to stop flashing. Then place positions 1 & 2 of the DIP switch in the down position and allow the unit to settle for approximately 10 seconds.
- d) Adjust pot R108 (*see Diagram 2*) until the **OHMMETER READS THE SAME AS THE 211**. **Adjustment Tolerance:** ± 0.02 ohms.
Note: Allow 20 seconds for both the ohmmeter and the 211 to settle after each adjustment.
- e) Place positions 1 & 2 of the DIP switch in the up position and dial the 211 to display 1950.0 ohms. Again, allow the "SIM" to stop flashing then place DIP switch position 1 & 2 down and allow unit to settle for approximately 10 seconds.
- f) Adjust pot R117 (*see Diagram 2*) until the **211 DISPLAYS THE SAME AS THE OHMMETER**. **Adjustment Tolerance:** ± 0.1 ohms.
- g) Place switches 1 and 2 of the DIP switch in the up position.
- h) Dial the 211 to 10.00 , 100.00 , 400.00 , 500.0 , 1000.0 and 1950.0 ohms, making sure the unit is within ± 0.03 ohms in the 000.00 ohms scale and ± 0.2 ohms in the 000.0 ohms scale.

Read Mode - Turn the 211 on in read mode. Allow 60 seconds for the unit to settle.

- a) Connect the decade box to the 211 using the 4-wire configuration. (*see Diagram 3*).
- b) Dial the decade box to 100, 400, 2000 ohms respectively. Allow the 211 approximately 10 seconds to settle between each setting. Compare the 211 readings to the previously recorded values in Table 1. **Tolerance:** ± 0.03 ohms in the 000.00 ohms scale and ± 0.2 ohms in the 000.0 ohms scale. Check several random resistance values to verify the unit is in spec.

TRANSMATION Products Group	Model 211 Field Calibration Procedure	DOCUMENT NO. 1-552	REV. D
	Created by: T.Tetreault	Date:14jul 92	PAGE 1 OF 5

Calibration Procedure Continued (All Revisions)

Restore to Normal Operation

- a) Place all DIP switches in the DOWN position.
- b) Turn the unit off, then on again.
- c) Press button to scroll to original recorded alpha type.
- d) Turn unit off.
- e) Restore DIP switches to original recorded positions.

NOTE: If the unit fails to meet any of its stated specifications after recalibration, call the factory to acquire a Return Authorization Number for repair.

211field.fh5

Table 1	
Decade Box	
0 ohm:	_____
400 ohm:	_____
2000 ohm:	_____
Alpha Value	
= 1.	____ _
DIP Switches	
<input checked="" type="checkbox"/> UP	<input type="checkbox"/>
	<input type="checkbox"/>
	<input type="checkbox"/>
	<input type="checkbox"/>
	<input type="checkbox"/>
	1 2 3 4 5

CUSTOMER PRECALIBRATION INFORMATION
(Record all information BEFORE calibration.)

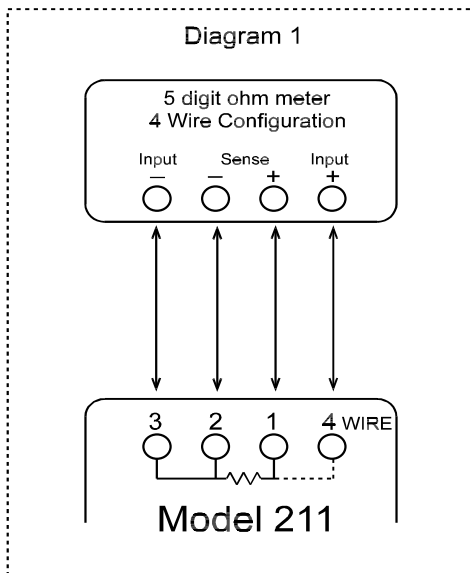
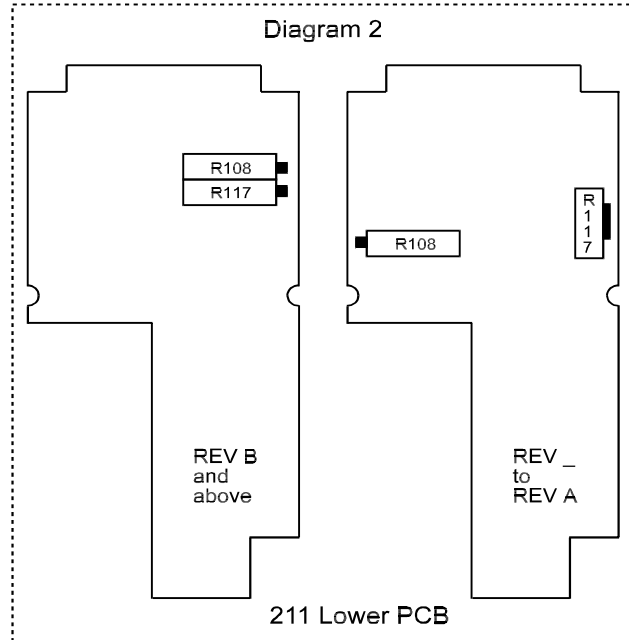

211 Source Mode 4-Wire Calibration
Connection Diagram

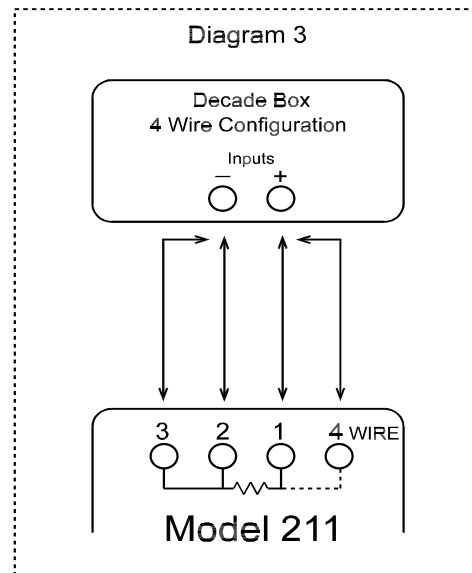

211 Read Mode 4-wire Calibration
Connection Diagram

Distributed by: M&M Control Service, INC. 800-876-0036
[Http://www.mmcontrol.com](http://www.mmcontrol.com) Email: Sales@mmcontrol.com