

# Differential Pressure Transducer

## Model PR-283



- 100% solid-state fused silicon pressure sensors
- Rugged, leakproof 17-4 PH stainless steel monolithic pressure cavities with no welds, O-rings, seams, or bonds
- Up to 3 field selectable ranges in a single unit
- Wide 12-40 VDC/12-35 VAC unregulated supply voltage
- Two temperature-compensated humidity output versions: 4-20 mA 2-wire or field selectable 0-5 VDC/ 0-10 VDC
- NIST traceable calibration
- Modular 316 stainless steel 3-valve monolithic manifold assembly (VM-705)
- Rugged NEMA-4 (IP-65) enclosure with external mounting bracket
- Short circuit and reverse polarity protected
- Conforms to EMC standards EN50082-1/EN55014/EN60730-1

The PR-283 incorporates sophisticated integrated circuits and new fused silicon monolithic cavity pressure sensors to not only provide a high level, fully conditioned and temperature-compensated output, but also to offer up to three (3) field selectable pressure ranges in one unit. The field selectable feature eliminates costly inefficiencies by providing a single unit which can be configured to cover all the pressure ranges for a particular application: for instance, 25.0, 50.0 and 100.0 psid in one unit. The 17-4 PH SS monolithic pressure cavity not only provides media compatibility for most of the applications, but also offers a leakproof solution for today's environmentally conscious customers. Two industry standard output versions are available: 4-20 mA 2-wire loop or field selectable 0-5 VDC/0-10 VDC. A wide 12-40 VDC or 12-35 VAC unregulated supply voltage and a broad 0°F - 180°F compensated temperature range ensure compatibility to most of the applications. A rugged NEMA-4 (IP-65) enclosure, gasketed cover, external mounting bracket, fully temperature-compensated NIST traceable accuracy and a liberal two year warranty are some of the features which make the PR-283 the industry's most reliable, rugged, and economical pressure transducer. A 316 SS three-valve isolation/nulling manifold (VM-705) is also available to be field installed without any piping interconnecting the two, thereby significantly reducing installation costs.

**DISTRIBUTED BY:**



**CONTROL SERVICE, INC.**

P.O. Box 250

P: 847.356.0566

GRAYSLAKE, IL 60030

F: 847.356.0747

DN283.1

Printed in USA

**WWW.MMCONTROL.COM**

## PR-283

The PR-283 sensing elements are 100% solid-state piezoresistive silicon strain gauge fused directly onto the 17-4 PH SS monolithic pressure cavity. The pressure cavity is machined out of a solid rod and does not incorporate any welds, seams, or bonds. In this way, the sensor not only offers excellent linearity, repeatability, and sensitivity, but also exhibits negligible hysteresis and withstands significant overpressure without zero shift. The monolithic nature of the cavity ensures not only leakproof operation but also enhances the overpressure and burst pressure specifications. The pressure cavity design incorporates novel techniques to isolate the fused silicon sensing element from installation related stress thereby ensuring zero integrity. The 17-4 PH SS offers excellent media compatibility to most of the industrial and commercial applications.

The PR-283 incorporates sophisticated integrated circuits to not only provide a high level, fully conditioned and temperature-compensated output, but also to offer field selectable flexibility which was unheard of in the industry. The PR-283 offers up to three field selectable pressure ranges in one unit. In this way, a customer does not need to know the exact pressure range prior to selection. A unit can be field configured for the desired pressure range. With fixed range units, in case of engineering error or incorrect selection, the only solution is expensive field recalibration or time consuming product exchange or replacement. Similarly, numerous units have to be kept in stock as spares to cover all ranges in case of field failure. The PR-283 with the field selectable pressure range feature eliminates the above mentioned costly inefficiencies. A single unit can be configured to cover all the pressure ranges in a particular application thereby eliminating any possibility of incorrect range selection. Additionally, one unit can be kept in stock and, in the event of a failure, it can be field configured thereby eliminating the need to stock numerous fixed range units.

On VDC output units, two additional field selectable options are available: dual outputs 0-5 or 0-10 VDC, and dual unregulated supply voltages 12-35 VAC or 12-40 VDC. By means of a dip switch, one can select the desired output for the specific application. As far as supply voltage is concerned, the unit automatically configures for AC or DC and no field selection is necessary. Another feature is that the output is fully protected from short circuit to ground, or if the supply voltage is applied by mistake to the output.

The mA output units can function over a wide unregulated supply voltage range of 12-40 VDC without any affect on calibration or performance. The unit has reverse polarity protection built in. As a result, it is next to impossible to damage the unit by mis-wiring. By using sophisticated low drop-out voltage regulators and CMOS integrated circuits, the mA output unit can drive very high output impedance. In fact, with only 12 VDC supply, the unit can drive 400 ohms. At 40 VDC, the unit is capable of handling up to 3000 ohms load. In this way, the output loop can be tied in series to multiple controllers, indicators and other devices without degrading the performance.

The PR-283 incorporates a rugged NEMA-4 (IP-65) fully gasketed, dustproof and splashproof enclosure. The enclosure has an external mounting bracket to facilitate field installation. A 1/2" (.875"/22.25 mm diameter) knock-out for conduit connection is also provided. A liquid tight cable connector is also supplied if the unit is not being hard wired. Once installed, the enclosure maintains its environmental rating and protects the electronics and the sensing element from condensation, corrosive contaminants and other environmental pollutants. The unit also has additional features for ease of installation including unpluggable terminal block, easily accessible zero and span trimmers, and conveniently located dip switch for field selection of multiple ranges.

The PR-283 is also available with a 316 SS three-valve isolation/nulling manifold (VM-705). The manifold assembly is designed to be field installed without any piping interconnecting the two, thereby significantly reducing installation costs. 316 SS fittings and adapters are provided with each assembly to connect the two units. The manifold assembly incorporates a rugged steel mounting bracket engineered to have the height and the center-to-center dimensions of both units in the same plane. In this way all the installer has to do is slip the PR-283 onto the manifold adapters and by tightening two compression fittings the installation is complete.

The VM-705 incorporates industrial quality bubble tight, multi-turn 316 SS needle valves to ensure accuracy and reliability. To form a leakproof, long-term reliable seal, the seat is machined out of Teflon. The manifold assembly can withstand 400°F (204°C) and 4800 psig (33096 kPa) pressure without compromising its performance.

# PR-283

## SPECIFICATIONS:

**Accuracy\*:**  $\pm 1\%$  FS

**Overpressure:** 300% of rated range

**Burst Pressure:** 500% of rated range

**Max Static Pressure:** 200% of DP range

**Supply Voltage:** 12-40 VDC  
12-35 VAC (VDC output units only)

**Supply Current:** VDC Units - 10 mA max.  
mA Units - 20 mA max.

**Enclosure:** 18 Ga C. R. Steel NEMA-4 (IP-65)

**Finish:** Baked on enamel - PMS2GR88B

**Conformance:** EMC Standards EN50082-1 (1992)  
EN55014(1993)/EN60730-1(1992) AS/NZ 3548  
1995 (EN55022: IEC/CISPR 22 1993)

**Compensated Temp Range:** 0°F to 180°F  
(-18°C to 82°C)

**T. C. Error:**  $\pm 0.025\%/^{\circ}\text{F}$  ( $.03\%/^{\circ}\text{C}$ )

**Media Compatibility:** Liquid/gases  
compatible to 316L stainless steel

**Port Connection:** 1/8" NPT

**Environmental:** 10-90% RH  
Non-Condensing

**Termination:** Unpluggable screw  
terminal block

**Wire Size:** 12 Ga max.

**Load Impedance:** 3K ohms max. at 40 VDC (mA  
output units)  
1K ohms min. (VDC output units)

**PR-283:** 1.7 lbs. (.75 kg)

**VM-705:** 5.2 lbs. (2.4 kg)

**\* Includes non-linearity and non-repeatability**

## ORDERING INFORMATION: PR-283-

| RANGE                                     | OUTPUT                                 |
|---|--|
| R1 (psig) 0 TO 5 / 0 TO 10 / 0 TO 20      | mA (4-20 mA 2-wire)                    |
| R2 (psig) 0 TO 25 / 0 TO 50 / 0 TO 100    | VDC (0-5 or 0-10 VDC field selectable) |
| R3 (psig) 0 TO 75 / 0 TO 150 / 0 TO 300   |  |
| R4 (kPa) 0 TO 35 / 0 TO 70 / 0 TO 140     |  |
| R5 (kPa) 0 TO 175 / 0 TO 350 / 0 TO 700   |  |
| R6 (kPa) 0 TO 500 / 0 TO 1000 / 0 TO 2000 |  |

**Ordering Information:** 3-Valve Manifold Part No: VM-705

**Example:** PR-283-R1-mA: With R1 Range which has three (3) selectable range options, 4-20 mA output.

**Caution:** Do not use on oxygen service, in explosive / hazardous environment or with flammable/combustible media.

# PR-283

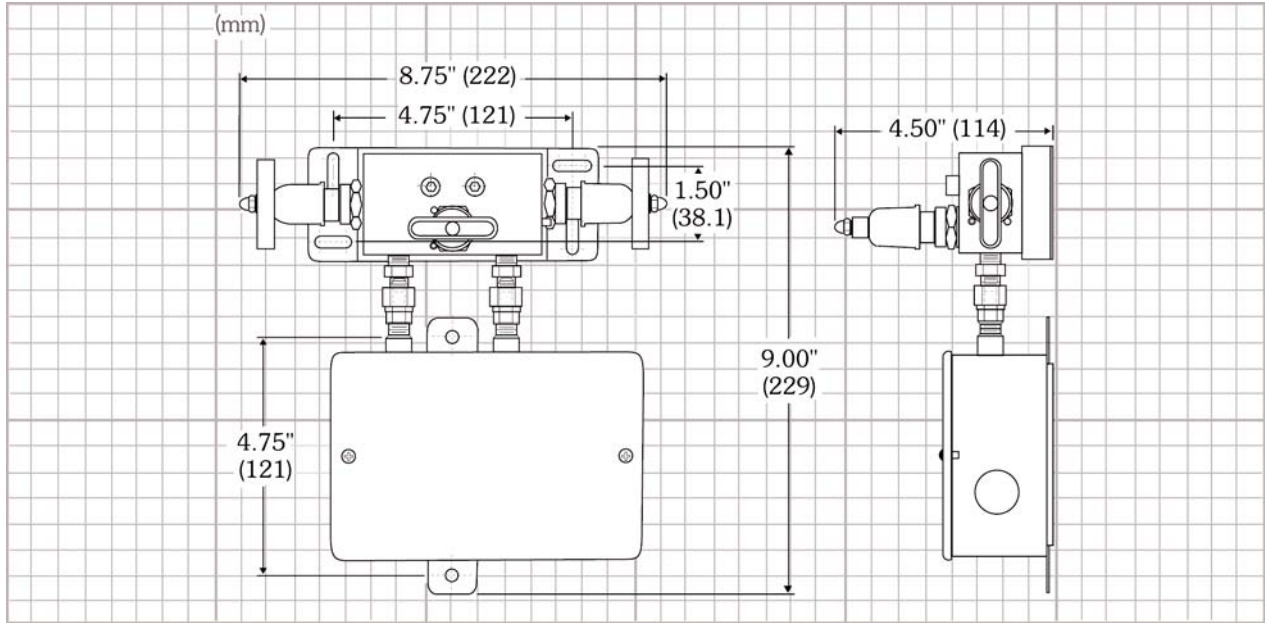

**WARRANTY:** MAMAC Systems, Inc. warrants its products to be free of defects in material and workmanship for a period of two (2) years from date of shipment. If a unit is malfunctioning, it must be returned to the factory for evaluation. A return authorization number (RMA) will be issued by the customer service department and this number must be written or prominently displayed on the shipping boxes and all related documents. The defective part should be shipped freight prepaid to the factory. Upon examination by MAMAC Systems, Inc., if the unit is found to be defective, it will be repaired or replaced at no charge to the customer. However, this warranty is void if the unit shows evidence of being tampered with, damaged during installation, misapplied, misused, or used in any other operating condition outside of the units published specifications.

MAMAC Systems, Inc. makes no other warranties or representations of any kind whatsoever, expressed or implied, except that of title. All implied warranties including any warranty of merchantability and fitness for a particular purpose are hereby disclaimed. User is responsible to determine suitability for intended use.

**LIMITATIONS OF LIABILITY:** The remedies of buyer set forth herein are exclusive and the total liability of MAMAC Systems, Inc. with respect to this order, whether based on contract, warranty, negligence, indemnification, strict liability or otherwise, shall not exceed the purchase price of the product upon which liability is based. **In no event shall MAMAC Systems, Inc. be liable for consequential, incidental or special damages.** MAMAC Systems, Inc. reserves the right to change any specifications without notice to improve performance, reliability, or function of our products.

Every precaution for accuracy has been taken in the preparation of this manual, however, MAMAC Systems, Inc. neither assumes responsibility for any omissions or errors that may appear nor assumes liability for any damages that result from the use of the product in accordance with the information contained in the manual.

**DISTRIBUTED BY:**



**CONTROL SERVICE, INC.**

P.O. Box 250

P: 847.356.0566

GRAYSLAKE, IL 60030

F: 847.356.0747