



56-T SERIES

TEMPERATURE ACTUATED WATER REGULATING VALVE

RELIABLE TEMPERATURE CONTROL DESIGNED FOR RUGGED APPLICATIONS

This thermostatic cooling control valve has everything you need for reliable temperature control. The Sterlco® 56-T Series Temperature Actuated Water Regulating Valve evenly regulates cooling water and other fluids in the most rugged applications. It's ideal for hydraulic power packaged equipment, hydraulic presses, or wherever reliable performance is required.

Sterlco's® self-modulating cooling control valves are temperature actuated, self powered, and applicable to cooling processes using water or other fluids. 56-T Series valves are available in eight different sizes. To ensure dependability, every valve is factory-tested three times in different temperature baths. For the temperature control you need, get the valve that can deliver.

FEATURES

- Precise control from 40° to 275°F
- Sizes from 3/8" to 2 1/2"
- Sturdy, brass alloy construction
- Heavy-duty, direct acting bellows
- Buna-N seat disc
- Replaceable seat beads
- 125# ANSI Flange (2" and 2 1/2" valves)



3/8", 1/2", 3/4", 1", 1 1/4", 1 1/2" FLOW CHART

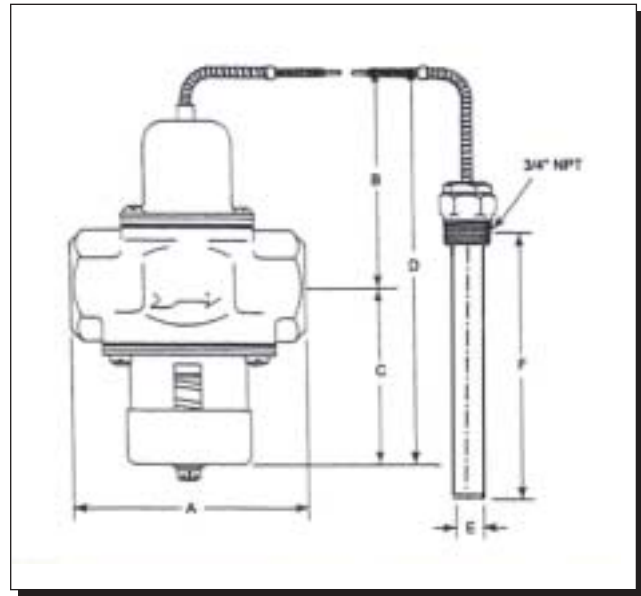
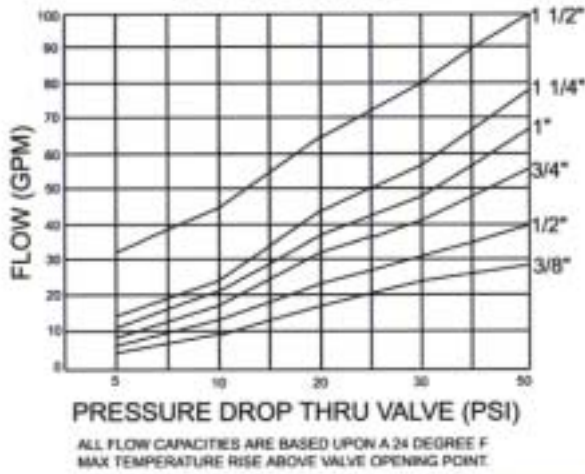

SPECIFICATIONS

	A (in.)	B (in.)	C (in.)	D (in.)	E (in.)	F (in.)	Width (in.)	Weight	Cv
3/8"	3 3/32	3 11/32	3 1/32	6 3/8	5/8	6	2 1/8	2lbs. 6oz	2.06
1/2"	3 3/32	3 11/32	3 1/32	6 3/8	5/8	6	2 1/8	2lbs. 6oz	4.38
3/4"	3 3/8	4 1/16	3 1/4	7 5/16	5/8	8 1/4	2 1/8	3lbs. 6oz	7.70
1"	4 3/4	4 3/16	3 27/32	8 1/16	5/8	8 1/4	2 3/4	6lbs. 2oz	9.72
1 1/4"	5 1/4	4 3/16	3 27/32	8 1/16	5/8	8 1/4	2 3/4	7lbs.	12.5
1 1/2"	5 5/16	7	6 5/16	13 5/16	9/16	8	2 3/4	10lbs.	14

2" and 2.5" FLOW CHART

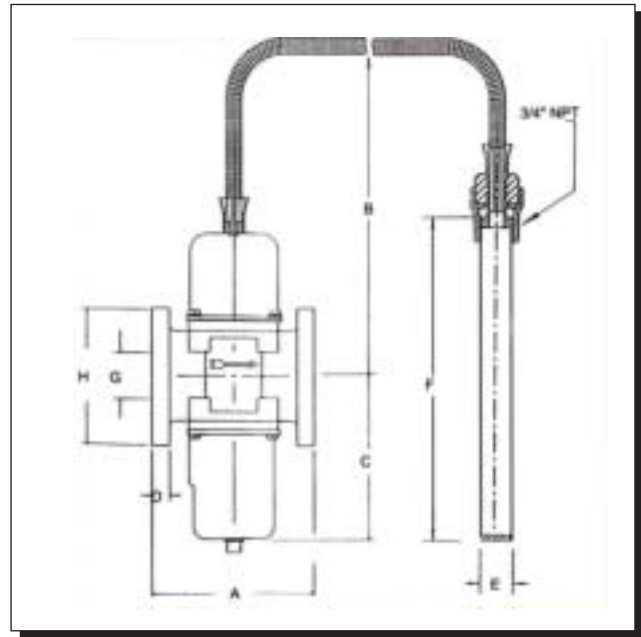
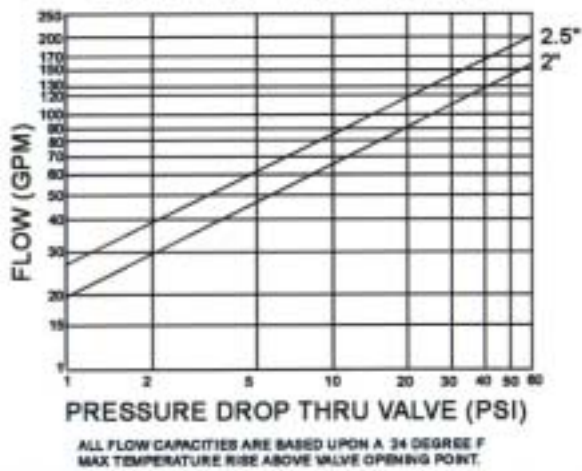

SPECIFICATIONS

	A (in.)	B (in.)	C (in.)	D (in.)	E (in.)	F (in.)	G (in.)	H (in.)	Weight	Cv	# of Holes	Hole Size	Bolt Circle
2"	6 5/8	9	6 3/8	5/8	3/4	11	2 1/4	6	22 lbs.	20	4	3/4	4 3/4
2 1/2"	6 3/4	9 1/2	6 5/8	11/16	3/4	11	2 3/4	7	30 lbs.	26	4	3/4	5 1/2

Size

3/8", 1/2", 3/4", 1", 1 1/4", 1 1/2", 2", 2 1/2"

Fluid Pressure Range

Up to 125 PSI for 3/8" through 1 1/4"

Up to 150 PSI for 1 1/2" through 2 1/2"

Standard Temperature Ranges

(opening point adjustment may be anywhere within the standard ranges shown)

Body

Brass Alloy Casting

Valve parts

Brass Alloy

3/8" through 1 1/4"

- 40°F - 100°F
- 60°F - 140°F
- 100°F - 175°F
- 125°F - 200°F
- 140°F - 240°F
- 200°F - 275°F

1 1/2" through 2 1/2"

- 60°F - 140°F
- 100°F - 175°F
- 160°F - 230°F

Standard Capillary Length

6' (for other capillary lengths, consult factory)

Valve Mounting

Any position

Standard Bulbs

- For 3/8" and 1/2" valve sizes: 5/8" x 6" with 3/4" union connection
- For 3/4", 1", and 1 1/4" valve sizes: 5/8" x 8 1/4" with 3/4" union connection
- For 1 1/2" valve sizes: 9/16" x 8" with 3/4" union connection
- For 2" and 2 1/2" valve sizes: 3/4" x 11" with 1" union connection

Special Bulbs

3/8" through 1 1/4" sizes: 9/16" x 3 1/4" with 1/2" union connection; 9/16" x 6 3/4" with 1/2" union connection. Available on special order. Please consult factory for details.

Seat Disc

Replaceable Buna-N

Seat Bead

Replaceable stainless steel (3/8" through 1 1/4")
Replaceable brass (1 1/2" through 2 1/2")

Temperature Adjustment

To adjust for lower temperature, turn adjusting screw counterclockwise. For higher temperature, turn clockwise

BULB WELLS (Available in Stainless Steel or Brass)

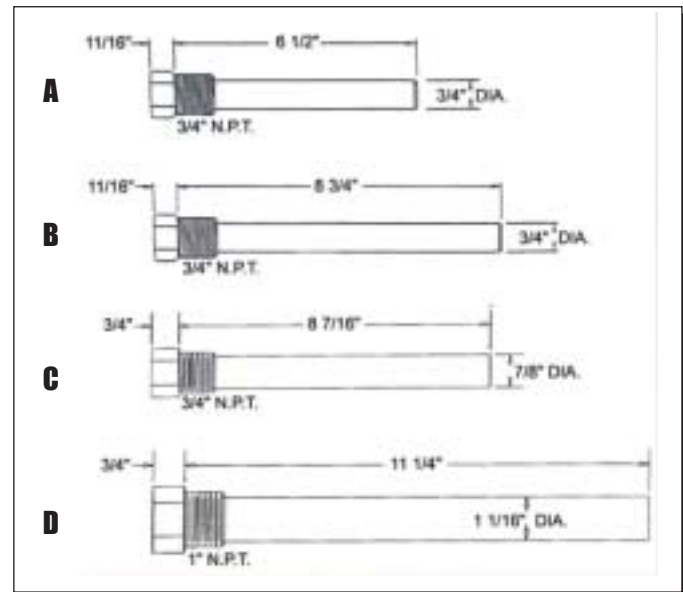

A: Used on 3/8" and 1/2" valves

B: Used on 3/4", 1", and 1 1/4" valves

C: Used on 1 1/2" valves

D: Used on 2" and 2 1/2" valves

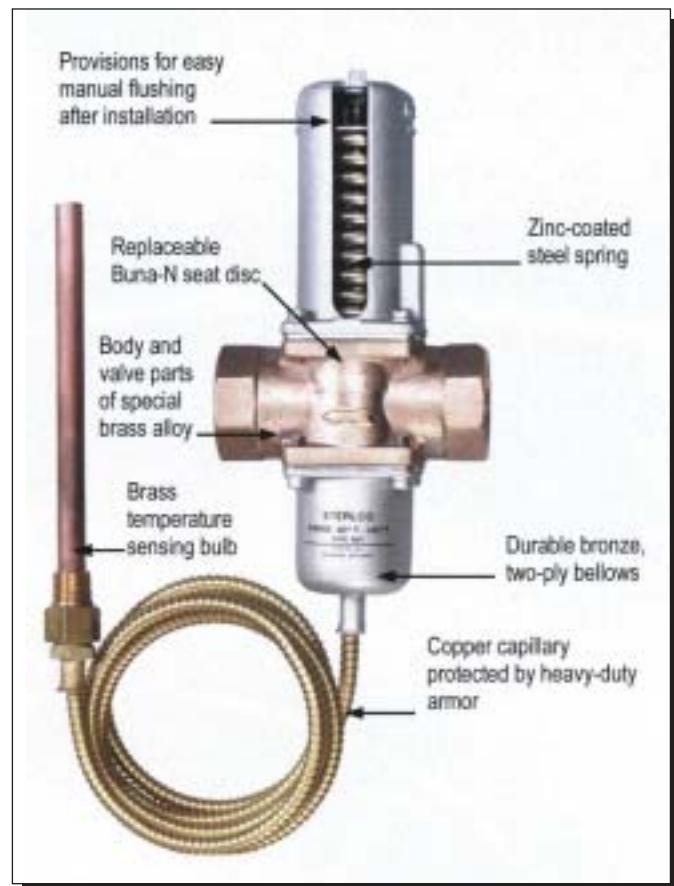

56 SERIES PRESSURE ACTUATED WATER REGULATING VALVE

The Sterlco® 56 Series Actuated Water regulating Valve features a compact, dependable design made from sturdy, brass alloy casting. To accommodate pressures from 70 to 260 PSI without changing springs, simply turn the adjustment screw at the base of the valve.

You can easily mount the valve in any position without mounting the brackets. The 56 Series valve comes with a sturdy actuating element with powerful bellows designed for use with open and hermetically sealed condensing units. The valve is designed with a zinc-coated steel spring and provisions for easy manual flushing after installation.

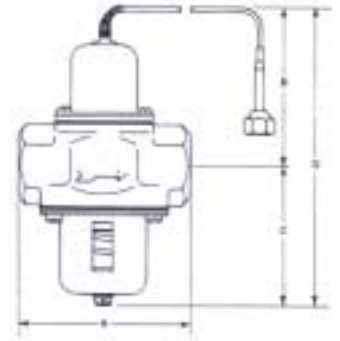

Head Pressure Range:	70-260 PSI
Water Pressure:	125 PSI
Head Pressure Connection:	1/4" flare, 30" capillary
Body:	Brass alloy casting
Seat Disc:	Buna-N
Seat Bead:	Stainless Steel
Spring Housing:	Enclosed steel for extra strength and protection

	A (in.)	B (in.)	C (in.)	D (in.)	Width (in.)	Weight	Cv
3/8"	2 3/16	3 5/32	2 27/32	6	2 1/8	2lbs. 2 oz	2.0
1/2"	3 3/32	3 11/32	3 1/32	6 3/8	2 1/8	2 lbs 6 oz	4.5
3/4"	3 3/8	4 1/16	3 1/4	7 5/16	2 1/8	3 lbs 6 oz	7.8
1"	4 3/4	4 3/16	3 27/32	8 1/16	2 3/4	6 lbs 2 oz	10.8
1 1/4"	5 1/4	4 3/16	3 27/32	8 1/16	2 3/4	7 lbs	12.5

OTHER PRODUCTS MANUFACTURED BY STERLING STEAM CONTROL PRODUCTS DIVISION:



150F Series
Temperature Control



Self-Cleaning
"Y" Strainers



Boiler Feed Units



De-Scaling System
and Fluid



Condensate Pumps
4100 Series



5200 W. Clinton Avenue

Milwaukee, Wisconsin 53223

Tel. 414.354.0970

Toll Free 888.777.4085

Fax 414.354.6421

©2002 Sterling, Inc.

www.steamcontrolproducts.com

STERLCO PRODUCTS INCLUDE: HAND RADIATOR VALVES • THERMOSTATIC TRAPS • FLOAT AND THERMOSTATIC TRAPS • INVERTED BUCKET TRAPS • CAST IRON STRAINERS • BRASS STRAINERS • TANK AND PROCESS TEMPERATURE CONTROL VALVES • BOILER FEED UNITS • CONDENSATE PUMPS