

# Heatguard® 115-H Series

## DESCRIPTION

The Heatguard® 115-H is a large sized high flow rate Temperature Actuated Mixing Valve that mixes hot water with cold to deliver hot water at a reduced temperature.

The Heatguard® 115-H has an outlet temperature range extending to 140°F and a flow rate of 30 gpm at 45 psi, making it ideal for application in large heating systems. It also has application in any installation requiring the delivery of reduced temperature hot water.

The Heatguard® 115-H is a high quality mixing valve incorporating Thermostatic Technology. It features a robust design based on the expertise gained from years of experience in the design and manufacture of safety valves. Every valve is tested for performance on an automated testing station during the assembly process.

The Heatguard® 115-H incorporates a thermostatic element that senses the outlet water temperature and reacts to maintain a stable delivery temperature.

The Heatguard® 115-H features an adjusting handle that can be locked at a desired temperature. Alternatively it can function in an adjusting mode, with the handle clearly marked to indicate the direction to turn to achieve hotter or colder water temperatures.

The Heatguard® 115-H is available as a base valve with union connections to suit the range of Heatguard® 115 Fittings Kits in 3/4" and 1" sizes, including sweat and threaded.

## FEATURES AND BENEFITS

Large sized valve with high flow rates:  
*Control larger systems with a single valve.*

Every valve is tested prior to shipping:  
*Specify and install with confidence!*

Robust, low complexity construction:  
*Superior reliability, improved user safety.*

Integral union connections on all three ports:  
*Easy and quick to install and service.*

## SPECIFICATION

A Temperature Actuated Mixing Valve shall be installed in conjunction with the water heating source to distribute tempered water to the system. The temperature actuated mixing valve shall control the delivered water temperature via a regulating piston made from engineering polymer. The valve shall be a Cash Acme Heatguard® 115-H.

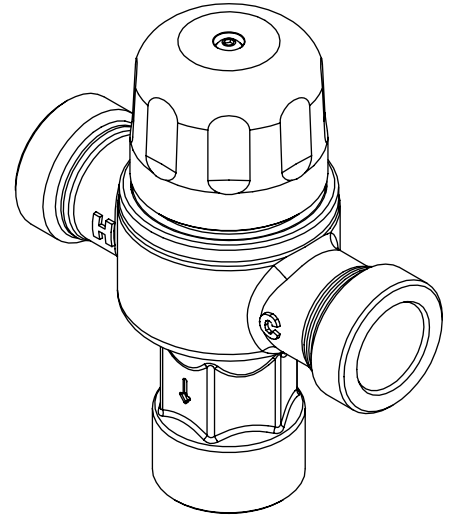

**HEATGUARD®**  
THERMOSTATIC MIXING VALVES

# Heatguard® 115-H Series

## TYPICAL INSTALLATION

The Heatguard® 115-H is a high performance Temperature Actuating Mixing Valve for use in heating systems.

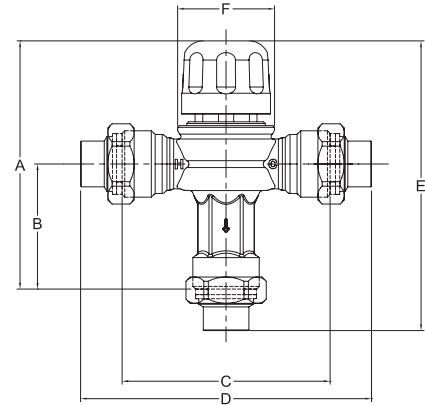
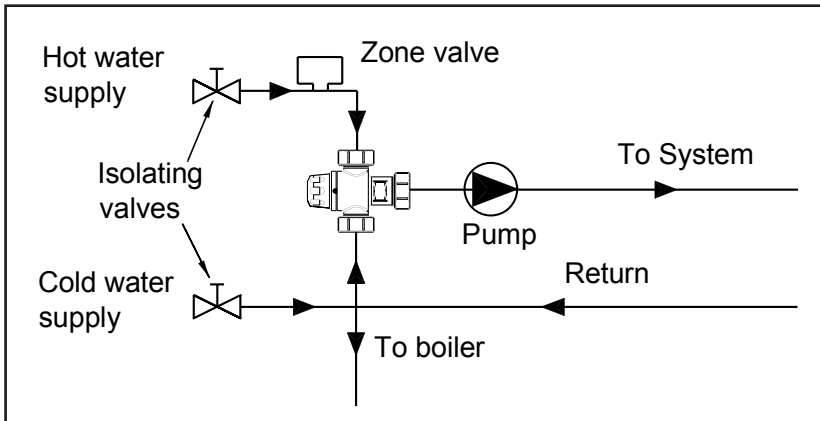

Dimensions	A	B	C	D	E	F
Base Valve	5.5 (138)	2.8 (72)	4.7 (119)	*	*	2.2 (56)
3/4" Sweat	5.5 (138)	2.8 (72)	4.7 (119)	6.6 (167)	6.5 (166)	2.2 (56)
1" Sweat	5.5 (138)	2.8 (72)	4.7 (119)	7.4 (189)	7.0 (177)	2.2 (56)
3/4" Threaded	5.5 (138)	2.8 (72)	4.7 (119)	6.6 (167)	6.5 (166)	2.2 (56)
1" Threaded	5.5 (138)	2.8 (72)	4.7 (119)	8.1 (205)	7.3 (185)	2.2 (56)
3/4" CPVC	5.5 (138)	2.8 (72)	4.7 (119)	6.7 (169)	6.6 (167)	2.2 (56)

## SPECIFICATION DATA

### Performance:

- Outlet temp. range . . . . . 95 - 140°F (35 - 60°C)
- Temp. hot supply . . . . . 195°F (90°C) max
- Temp. cold supply . . . . . 40 - 80°F (4 - 27°C)
- Temp. stability . . . . . +/- 3°F (1.7°C)
- Working pressure, max. . . . . 145 psi (1,000 kPa)
- Flow rate, maximum . . . . . 50 gpm (190 L/min)
- Flow rate, minimum . . . . . 2.5 gpm (10 L/min)

### Materials:

- Body . . . . . Bronze
- Seals . . . . . Nitrile elastomer
- Springs . . . . . Stainless steel
- Fitting . . . . . Brass
- Internal . . . . . Brass
- Piston . . . . . Engineered polymer
- Guide Tube . . . . . Engineered polymer

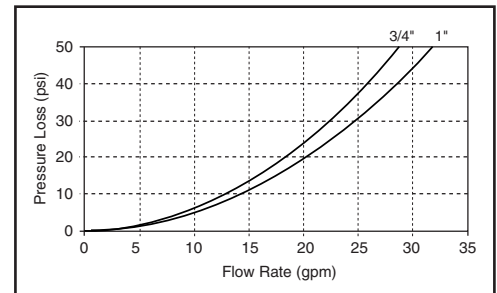

## CONNECTIONS (sold separately)

- Sweat . . . . . 3/4" and 1"
- Sweat w/ check . . . . . 3/4" and 1"
- Threaded (NPT) . . . . . 3/4" and 1"
- Threaded (NPT) w/ check . . . . . 3/4" and 1"
- CPVC . . . . . 3/4" and 1"
- CPVC w/ Check . . . . . 3/4" and 1"

## CERTIFICATIONS

The Cash Acme Heatguard® 115-H is certified to ASSE 1017 and CSA B125.  
The Cash Acme Heatguard® 115-H is listed by ASSE and IAPMO.