

A-89 and A-43CRF Pressure Reducing Boiler Feed Valves

DESCRIPTION

The Cash Acme A-89 Series is a highly competitive Boiler Feed Valve that automatically and accurately reduces system pressure to 14 psi.

These innovatively designed A-89 Valves feature a balanced piston construction for closer outlet control regardless of fluctuations in inlet pressure. A rapid fill feature incorporates a larger seat for higher capacity, and an improved back-check device ensures greater water system protection.

The **Cash Acme A-89** has threaded ends; the **A-89C** features a sweat copper union inlet. Both valves feature brass bodies and inbuilt strainer screens. Standard reducing pressure setting is 14 psi with an adjustment range from 2 to 30 psi. Maximum inlet pressure is 200 psi. The **Cash Acme A-89** is available in a 1/2" size only.

The **Cash Acme A-43CRF** is an economical boiler feed valve that automatically reduces system water pressure to 14 psi and holds it there for trouble free heating service.

It is available with a bronze body, inbuilt strainer, sweat copper union inlet and features an inbuilt check valve to retard reverse flow of boiler water.

The **Cash Acme A-43CRF** incorporates a unique rapid fill device which is basically a time saving feature. When in use, it allows the fast filling and purging of a hydronic system. And since the water flow is passing directly through the valve and into the system, there is always the protection of the built in strainer.

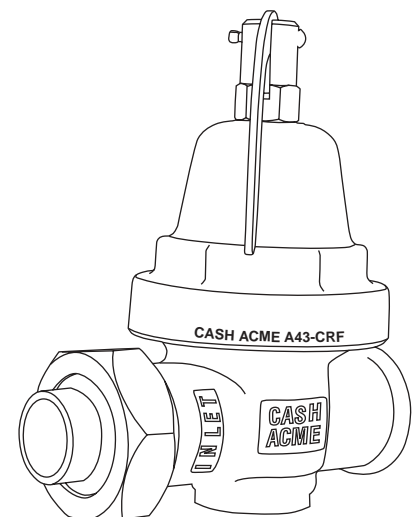
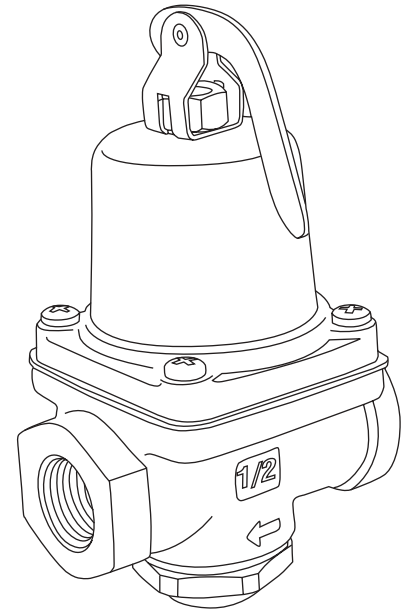

FEATURES AND BENEFITS

Inbuilt check valve:

Retards reverse flow of boiler water.

Economical and easy to install:

Saves money and time!

Every valve is tested for performance prior to shipping:

Specify and install with confidence!

A-89 and A-43CRF Pressure Reducing Boiler Feed Valves

TYPICAL INSTALLATION

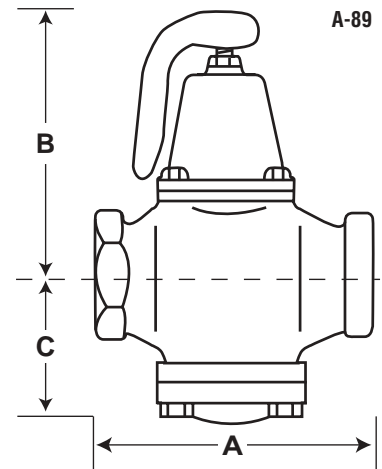
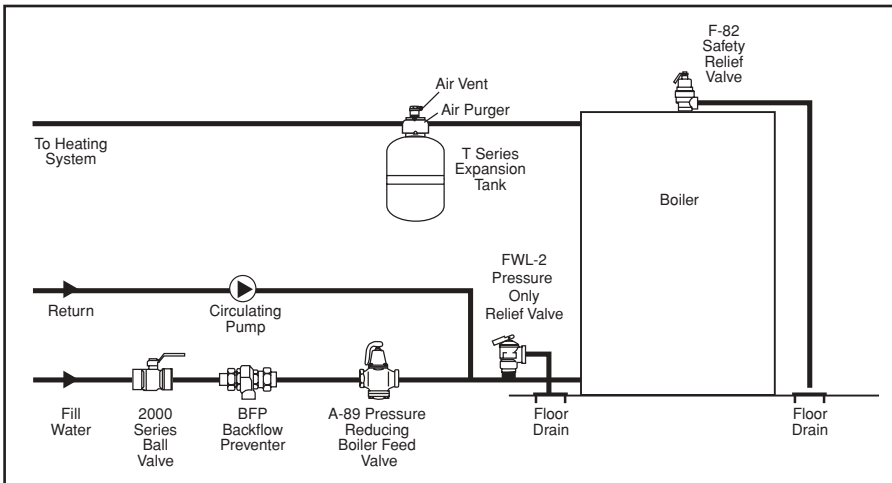

Dimensions	A	B	C
A-89	37/16"	43/16"	113/32"
A-89C	41/8"	43/16"	113/32"
A-43CRF	4.3125"	3.9375"	.875"

SPECIFICATION DATA

Performance:

Outlet pressure range 2-30 psi (Factory set 14 psi)
 Maximum inlet pressure 200 psi
 Service Water

Materials:

Body A-89: Brass, A-43 CRF: Bronze
 Strainer Stainless steel
 Seat Stainless steel
 Seat Disc EP
 Diaphragm EP and Nylon
 Spring Chamber Brass
 Piston Brass
 O-Ring EP
 Bottom Plug Brass

CONNECTIONS

Sweat Copper Union 1/2"
 Threaded (NPT) 1/2"