

Heatguard™ 145 Series

DESCRIPTION

The Heatguard™ 145 is a compact Thermostatic Mixing Valve that mixes hot water with cold to deliver tempered water at a constant temperature.

The Heatguard™ 145 is specifically intended for use in conjunction with individual faucets and electronic sensor faucets.

The Heatguard™ 145 is a compact, high specification product incorporating the latest in Thermostatic Technology. It features a robust design based on the expertise gained from years of experience in the design and manufacture of safety valves. Every valve is tested through a range of tests on an automated testing station during the assembly process. The valve is ASSE 1016 listed for individual point-of-use applications.

The Heatguard™ 145 features a rapid response thermostatic element for superior control. The thermostatic element senses the outlet water temperature and reacts to maintain a constant delivery temperature even under changing flows or variations in supply temperatures or pressures. It provides stable operation at flow rates as low as 0.5 gpm. The valve also reduces the outlet flow to a trickle in the event of a cold water supply failure.

The Heatguard™ 145 features a snap-on cover over a spindle mechanism that requires a special tool to adjust the temperature. The special tool is provided with each valve.

The Heatguard™ 145 has inlet connections to suit a $\frac{3}{8}$ " flexible hose connector or a compression connection to $\frac{3}{8}$ " OD tube. It has a $\frac{3}{8}$ " NPT female thread on the outlet which allows adaptation to any connection type.

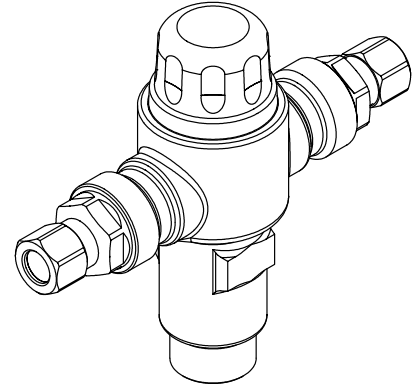

HEATGUARD™
THERMOSTATIC MIXING VALVES

FEATURES AND BENEFITS

Compact design:

Easily fits under or behind a single basin.

Accurate temperature control with flows as low as 0.5 gpm:

*Increased user comfort and convenience,
(especially with sensor faucets).*

Robust, low complexity construction:

Superior reliability, improved user safety.

Total flow shut-off if cold supply fails:

Greater end user safety.

Listed by IAPMO (cUPC) and ASSE (1016-T):

Inspector friendly, peace of mind!

SPECIFICATION

A Thermostatic Mixing Valve shall be installed on each lavatory faucet and/or sensor faucet. The valve shall be ASSE 1016 and cUPC listed. The thermostatic mixing valve shall control the delivered water temperature via a regulating piston made from engineering polymer. The valve shall have integral poppet style check valves on both inlets with a positive seal of the poppet onto an elastomer seat to prevent cross connection from hot to cold. A special tool shall be required to adjust the outlet temperature and the adjusting mechanism shall be hidden by a snap-on cover. The valve shall be a **Cash Acme Heatguard™ 145**.

Heatguard™ 145 Series

DESCRIPTION

The Heatguard™ 145 is a high performance Thermostatic Mixing Valve used to supply single outlets. It can be used to supply sensor faucets or two handle manual faucets.

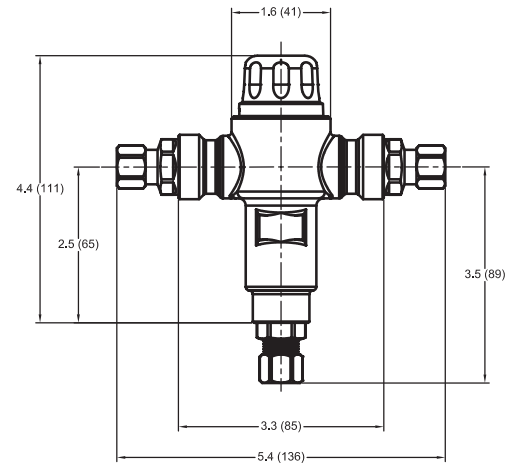
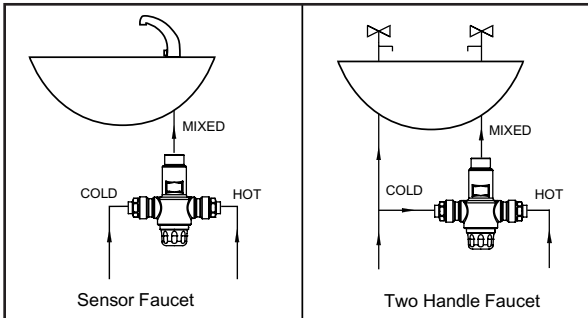

SPECIFICATION DATA

Performance:

- Outlet temperature range95 - 115° F (35 - 46° C)
- Temp. hot supply195° F (90° C) max.
- Temp. cold supply39 - 80° F (4 - 27° C)
- Temp. stability+/- 3° F (1.7° C)
- Working pressureMax. 145 psi (1,000 kPa)
- Flow rate, maximum5.5 gpm (21 L/min)
- Flow rate, minimum0.5 gpm (2 L/min)

Materials:

- BodyBronze
- SealsNitrile elastomer
- SpringsStainless steel
- FittingBrass
- InternalBrass
- PistonEngineered polymer

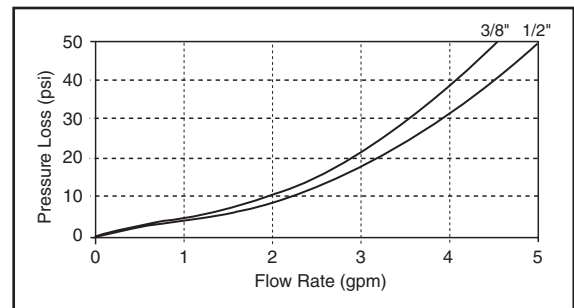

CONNECTIONS

- Sweat w/ check1/2"
- Comp. w/ check1/4" ID Tube (3/8" OD) and 1/2" ID Tube (5/8" OD)

CERTIFICATIONS

The Cash Acme Heatguard™ 145 is certified to ASSE and cUPC.