

EB-75 Compact Iron Body Regulating Valve For Water Service

DESCRIPTION

The Cash Acme EB-75 is a compact; iron-body pressure reducing and regulating valve designed for installations where small size and economy are important, and where local codes allow the use of iron body regulators for water service.

The EB-75 Regulators are available in 1/2" and 3/4" sizes. This regulator is intended for use where supply line inlet pressure does not exceed 300 psi. The EB-75 is suitable for either cold or hot (to 180° F) water service. Ideal for domestic installations, it automatically reduces and regulates inlet pressures down to the standard factory setting of 45 psi.

The **Cash Acme EB-75** is most frequently used in household water installations. It provides more than adequate capacity for a large majority of residential requirements.

FEATURES AND BENEFITS

Inbuilt back-pass check:

Allows water to flow back through the regulator in cases of thermal expansion caused by hot water heating devices.

Every valve is tested for performance prior to shipping:

Specify and install with confidence!

Fully pressure-balanced piston:

Automatically reduces and regulates high inlet pressures from a maximum of 300 psi down to 45 psi at standard factory setting.

SPECIFICATION

A pressure reducing valve shall be installed. The valve shall have an iron body, stainless steel seat ring, brass internals and a nylon reinforced, EP diaphragm. The valve shall be adjustable from 10 to 70 psi. The valve shall be a **Cash Acme EB-75 Regulating Valve**.

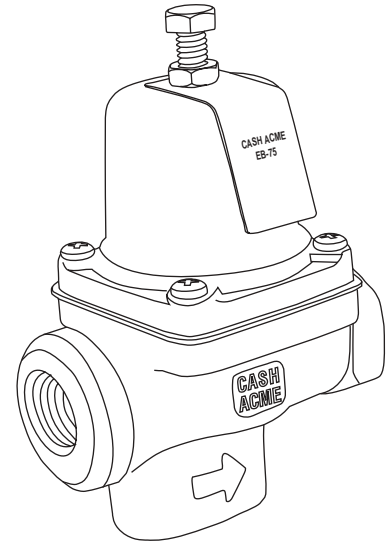

EB-75 Compact Iron Body Regulating Valve For Water Service

TYPICAL INSTALLATION

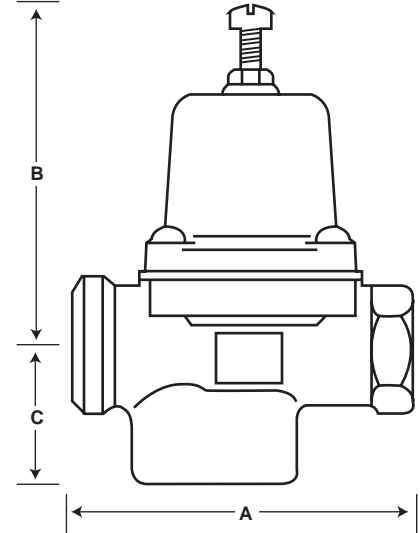
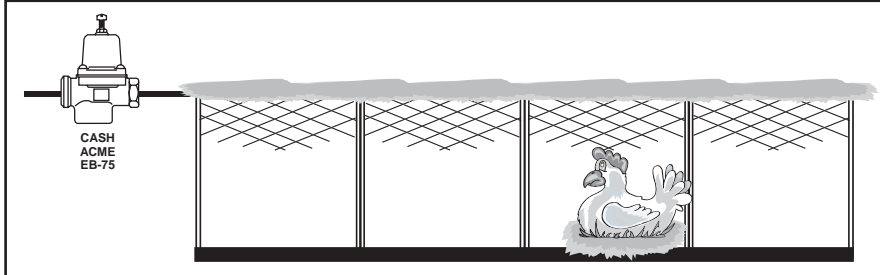

SPECIFICATION DATA

Performance:

- *Outlet pressure range10-70 psi
- Maximum temperature180° F
- Maximum initial pressure300 psi
- ServiceWater
- *0-20 psi also available, please contact the factory

Materials:

- BodyIron
- Spring ChamberIron
- Seat RingStainless steel
- DiaphragmEP nylon reinforced
- Adjusting SpringSteal (zinc plated)

Dimensions	A	B	C
1/2"	3 5/8"	4"	1 13/16"
3/4"	3 5/8"	4"	1 13/16"

CONNECTIONS

Threaded (NPT)1/2" and 3/4"

EB-75 Water Capacity (gpm)

Valve Size	P ₂ VAR (psi)	Differential Pressure P ₁ -P ₂ (psi)			
		10	25	50	100 Or More
1/2" - 3/4"	5	3	4	4 1/2	5 1/2
	10	6	8	10	11
	15	8	11	13 1/2	15
	20	9 1/2	13	15 1/2	17