

00111110000111 SAFETY 000011110001111010101000011110000001111100001110
00001111000000111110000111 RELIABILITY 000011110001111010101000011110000
111000111101010100001111000000111110000111 EFFICIENCY 000011110001111010
000000111110000111 COMPLIANCE 0000111100011110101010000111100000011111
1101010100001111000000111110000111 PERFORMANCE 00001111000111101010100

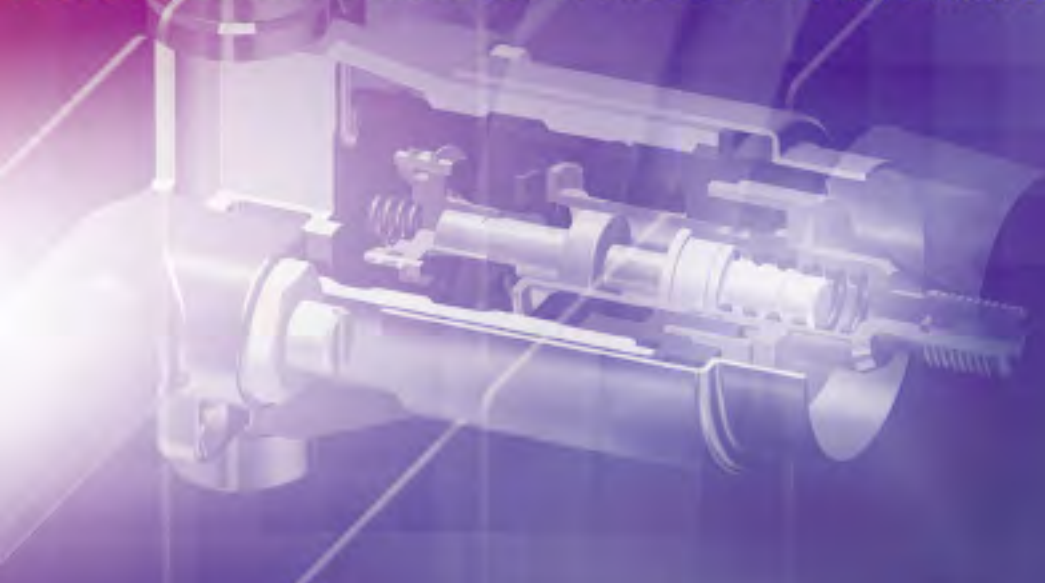

Water Tempering Innovation Since 1891

SAFETY 00001
11110000111
100001111000
0111 COMPLIAN
110000001111

- Thermostatic Lavatory Faucets
- Lead Free* Tempering Valves
- Combination T/P Tempering Valves
- Thermostatic Tempering Valves
- Master Tempering Valves
- Single and Multi-Valve Hi/Los
- Emergency Tempering Valves
- Lavatory Tempering
- Surface Mounted Showers
- Pressure Balancing Valves
- Alarm Systems

POWERS™

* The wetted surface of this product contacted by consumable water contains less than one quarter of one percent (0.25%) of lead by weight.



Over a century ago, smarter, better, and safer water tempering ideas began to flow...

During Chicago's World Columbian Exposition in 1893, the first Powers gradual acting, vapor disk thermostat was unveiled, along with such life-changing inventions as long-distance phone lines, the first adding machine, and the first gas-powered motorcar in America.

Founded in 1891 by William Penn Powers, the Powers Regulator Company began its history of innovation and leadership in water temperature control. Twenty years earlier in 1874, Joseph Watts, an inventor and entrepreneur, set up shop in Lawrence, Massachusetts. A skillful machinist and brass finisher, Mr. Watts amassed 18 patents and pioneered the first pressure reducing valves, used to regulate water, steam and air in textile mills. In the decades that followed, Watts became the most recognized and respected name in plumbing; and Powers went on to establish major milestones in water tempering innovation. Always mindful of each other's contribution to the industry, the two companies expanded the possibilities of water management throughout the 20th century.



Today, after a combined 250 years of innovation, Watts and Powers are united as

one company. As the one and only leader in water tempering technology, we have begun our second century together with a renewal of our long-time commitment to you: Smarter, better and safer water tempering ideas are flowing your way.

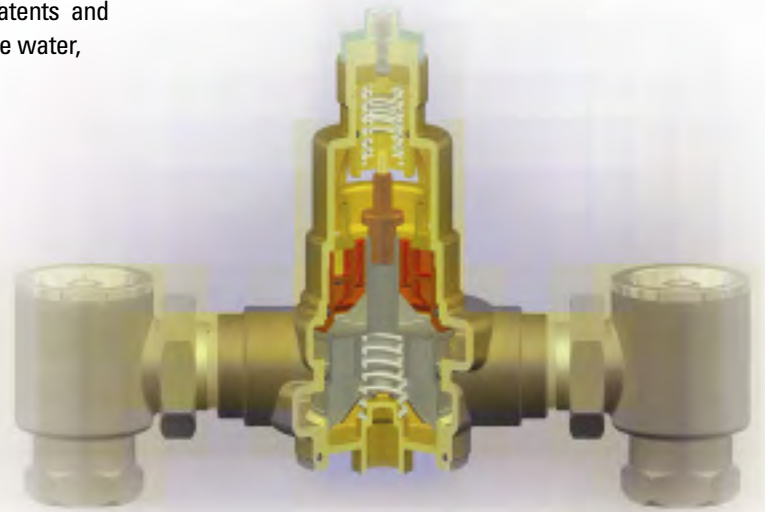

POWERS, a Tradition of Innovation and Excellence

Yesterday...

1891
Powers Regulator established



1923
First pressure balancing shower valve "Style A" mixer



1946
"Type H" thermostatic shower mixer



1889
William Penn Powers invents vapor disc thermostat



1919
First high-capacity master mixing valve "Type C" mixer



1939
Powers "System A" supply fixture with recorder

















1960
HydroGuard 420 bath and shower valve

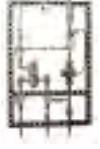

Table of Contents

- **Introduction and History**
 Watts and Powers.... legacies in tempering valve innovation and design with nearly 250 years of combined leadership 1
- **Tempering Technology**
 Superior paraffin-based actuation technology provides unprecedented speed and accuracy 2-3
- **Bath and Shower Standards**
 A closer look at ASSE 1016 and valve Types T, P and T/P 4-5
- **Solutions by Application**
 A quick reference guide that matches tempering valve applications to Powers products 6-7
- **ASSE Standards**
 Side-by-side comparison of ASSE safety standards including ASSE 1016, 1017, 1062, 1069, 1070 and 1071 8-9
- **Distribution Valves and Systems**
 HydroGuard® XP master tempering valves, single and multi-valve Hi-Los, supply fixtures and PowerStations. ASSE 1017 10-11
- **Emergency Tempering Solutions**
 HydroGuard® tempering solutions for emergency appliances including eye/face washes, drench showers and combination units ASSE 1071, ANSI Z358 12
- **Industrial Valves and Controllers**
 Self-operating and pneumatically actuated valves for mixing and industrial process applications featuring Flowrite, #11, and Accritem brands. 13
- **Bath and Shower Solutions**
 Pressure balancing and combination T/P valves and systems for all applications featuring HydroGuard®, Biltmore and HydroPanel™ brands. ASSE 1016 14-18
- **Lavatory Tempering and Hot Water Solutions**
 HydroGuard® tempering valves for single and multi-bank lavatories, hot water heaters and whirlpools. ASSE 1070 19
- **Specialty Products**
 ADA compliant products including metering faucets and infrared showers 20

Today...

<p>2000 Powers introduces paraffin actuation</p>  <p>480 first lavatory mixer to control to 0.5 gpm</p> 	<p>490 multi-unit lavatory mixer</p>  <p>e420 first T/P shower valve with single actuation technology</p> 	<p>2002 e490 multi-lavatory mixer with integrated checks</p> 	<p>2004 Super capacity tempering stations to 750 gpm</p> 	<p>LM490/495 next generation lavatory and tempering</p> 	<p>2005 Automatic Balancing Valve</p> 	<p>2010 TempTAP thermostatic lavatory faucet</p> 
<p>2001 Watts acquires Powers Single valve Hi-Lo e430/1430</p> 	<p>Powers pioneers paraffin in large valves, introduces patented "expandable restrictor" for low flow ES Series for emergency fixtures with patented dual internal by-pass</p> 	<p>2003 POWERSTATION™ self-contained tempering and recirculation station</p> 	<p>e700 first affordable combination T/P shower valve</p>  <p>e480 first T/P listed lavatory mixer to 0.5 gpm</p> 	<p>2008 Next Generation Master Mixing</p> 		



Better water tempering installations start with better T/P valve technology...

HydroGuard® T/P

**paraffin-based valve actuation technology
is the force behind today's smarter, safer,
lower-cost valve installations.**

Only Powers can offer you an affordable combination shower valve that meets the highest T/P requirements set by ASSE 1016 – because only Powers offers you single-valve, high-speed, paraffin-based valve actuation technology.

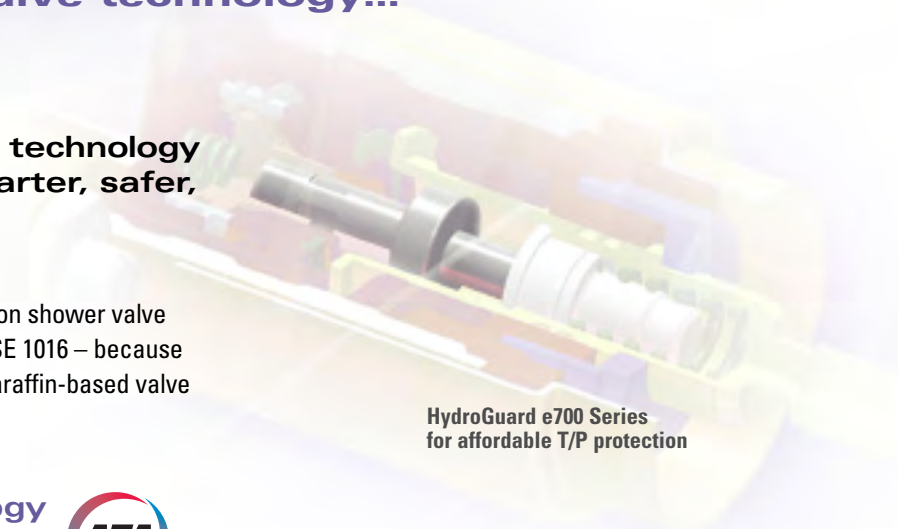

HydroGuard e700 Series
for affordable T/P protection

Advanced Activation Technology How it works ■



At the core of our T/P shower valves is a paraffin sensor that operates on the principle of converting heat energy into mechanical energy, using the expansion of paraffin from a solid to a liquid state. As shown in the illustration

below, when the temperature of the water enveloping the sensor increases, the expansion of the paraffin actuates the valve piston. As the water cools, the paraffin contracts into a solid, and the valve piston returns to its starting position.

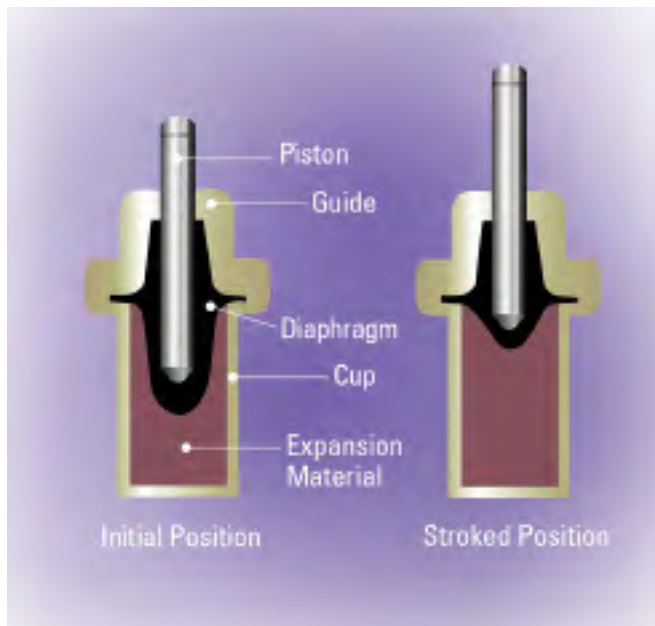

Better for your business ■

By perfecting single valve, paraffin actuation technology, Powers is able to produce smaller valves that provide greater user protection by way of combined temperature/pressure regulation. At the same time, the technology has enabled us to produce larger T/P valves that feature unparalleled low flow control. Most important, the benefit to you and your customers is a wide range of safer, better performing, and more cost-effective valve solutions.

HydroGuard paraffin actuation technology is simple, reliable, field-proven, tested to one million cycles – and the valve meets the stringent T/P requirements of ASSE 1016.

Simple, efficient, proven reliability ■

Powers' innovation brings you the right combination of safety, performance and value. Whether your tempering applications require large valves or small, all of our HydroGuard® T/P solutions feature single-valve, paraffin-based, thermal actuation. This assures you of many advantages, including the following:

- Valve actuates near instantaneously to temperature changes
- Provides superior temperature control at low flows, down to 0.5 gpm
- Reduces overall valve size for easier installation in shallow wall depths
- Economically achieves total ASSE 1016 T/P protection of users
- Won't stick or seize due to harsh water conditions



Price/Performance Continuum

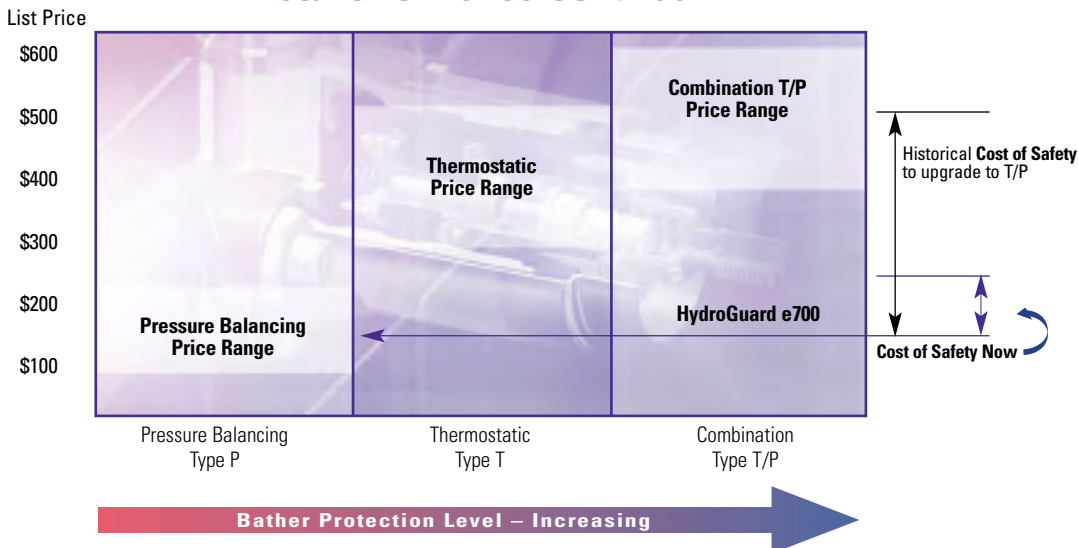

HydroGuard® T/P valves offer your customer a safer and more cost-effective installation, compared to traditional pressure balancing valves.



Bath & Shower Standards ASSE 1016

Cost, performance and risk prevention are three important factors to consider when evaluating valve technology options. Proper assessment is guided by the standards published by the American Society of Sanitary Engineers (ASSE). The latest ASSE 1016 standard defines a hierarchy of shower valve types that correspond to a range of options around cost, performance and risk.

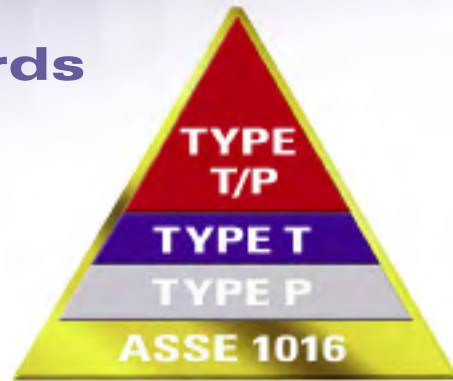

Type P: Lowest Protection / Lowest Cost ■

While pressure-balancing valves will compensate for pressure fluctuations within a plumbing system, these types of valves cannot make adjustments for sudden or gradual changes in supply temperature. If hot water supply line temperature unexpectedly increases to a dangerous level while inlet water pressure remains constant, the pressure balancing valve will continue to pass water but at a dramatically increased temperature.

- Pressure-balancing valves react to water pressure changes only. They are not designed to sense temperature changes and so do not provide true temperature regulation.
- Pressure-balancing valves can provide some level of protection against scalding — when limit stops are adjusted seasonally.
- Pressure-balancing valves do not provide complete protection when coupled with upstream thermostatic valves (master mixers) in the event of a master mixer valve failure.

Type T: Higher Protection / Higher Cost ■

Thermostatic valves manage both temperature and minimal pressure changes unlike pressure balancing valves which manage only pressure. Key features and limitations are listed below.

- Delivers blended water at a constant selected temperature
- Adjustable limit stop to prevent excessive handle rotation
- Temperature sensing is key advantage over Type P valves
- No need to adjust limit stop season to season
- Manages only 20% pressure fluctuations, not 50%
- Three to four times more cost than Type P valves

Type T/P: Highest Protection / Highest Cost — Until Now ■

Also known as combination valves, Type T/P valves are required to meet ASSE 1016's most stringent performance requirements for both temperature and pressure changes. However, widespread specification of Type T/P valves has been impeded by their relatively higher cost — until now.

Powers Type T/P valves provide the highest protection, at a lower cost. In fact, Powers HydroGuard® T/P valves are hundreds of dollars less than traditional Type T/P valves and very close to the cost of basic Type P valves. Better technology has enabled us to reduce the cost of safety to an easy-to-specify level.

- Allows water to be held in the system at higher temperatures
- Delivers water at safe temperatures to the bather
- Minimizes the risk of scalding
- Minimizes the risk of Legionella growth in the system
- No seasonal adjustment of the limit stop is required
- Saves potentially thousands of dollars in maintenance costs over the life of a system

Powers HydroGuard®
 Type T/P shower valves
 meet the most stringent
 requirements of ASSE 1016
 – at a cost that makes them
 easy to specify over basic
 Type P valves.



ASSE 1016 Hierarchy of Protection

Valve Type	Description	Protection Against Supply Temperature Changes	Protection Against Supply Pressure Fluctuations Up to 50%
Type T/P	Both temperature and pressure regulation	YES	YES
Type T	Thermostatic for temperature and some pressure regulation	YES	NO
Type P	Pressure balancing for pressure regulation	NO	YES

Scalding ■

At a water temperature of 130°F, only 20 seconds of exposure can produce a first-degree burn. To control against scalding, facilities need to control the water temperature in their systems at the point of use. Powers Type T/P valves respond near instantaneously to temperature fluctuations and to supply fluctuations up to 50%.

Cost and Value ■

For total protection, specify HydroGuard® total control. Of the three types of bath and shower valves recognized by ASSE 1016, only Powers HydroGuard® Type T/P shower valves meet the most stringent requirements of ASSE 1016 – and they do so at a per-unit cost that is comparable to basic Type P valves.

Infection ■

Legionella, which can be contracted by inhaling airborne water droplets containing the bacterium, thrive within a narrow water temperature range of 68 –122°F. To control the disease, facilities need to control the temperature of the water in their storage and delivery systems. Type T/P combination valves enable this by addressing the risk of exposing users to scalding.









Solutions by Application

Every Powers valve is engineered to solve real-world application needs



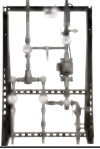

- Commercial** – hotel/motel, office, multi-family, fitness
- Institutional** – healthcare, education, corrections
- Industrial** – factory, process, safety

Commercial Water Distribution











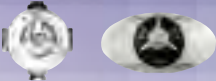



Application	Valve Type	Description	Standards Compliance
	HydroGuard® XP MM430 LFMM430	Water tempering in 5 sizes to 208 gpm	ASSE 1017, CSA B125 
High and Low Capacity Water	HydroGuard® XP SH1430 LFSH1430	Low to high flow valve from 1 to 200 gpm	ASSE 1017, CSA B125 
	PowerStation™	Water tempering with built-in recirculation line, pump, aquastat and balancing valve	ASSE 1017▲, CSA B125▲ 
	HydroGuard® Multiple Valve Hi/Lo	Low to high flow for demand up to 700 gpm	ASSE 1016/1017▲, CSA B125▲ 
	HydroGuard® LM490, LFLM490, MM430, LFMM430 Supply Fixtures, SH1430 and LFSH1430	Multiple configuration tempering for specific	ASSE 1016/1017▲, CSA B125▲ 
Lavatory Tempering	HydroGuard® LM490 Thermostatic	Hot water heater tempering	ASSE 1017, CSA B125 
High Temperature Alarm	AquaSentry 2® – 460	Used in conjunction with master tempering valves to monitor temperature	UL†, CSA 

Industrial Process

Application	Valve Type	Description	Standards Compliance
Self-Operating Regulators	#11- 595 Series	Bronze valves for heating, cooling, mixing and by-pass	Not applicable 
Heavy-Duty Globe Control with Pneumatic	Flowrite II® 593/596/597 Series	Bronze (1/2" – 2") and iron (2-1/2" – 6") for steam and water modulating mixing and by-pass	ASME/ANSI B16.1 
Rigid and Remote Bulb Blind Controllers	Accritem® 744 Series	Non-indicating, air and water operated	Not applicable 

▲ Individual Valves
† Transformer

Commercial Point-of-Use

Application	Valve Type	Description	Standards Compliance	
Bath and Shower Tempering	HydroGuard® T/P e420 Series Combination	High end T/P protection ideal for healthcare facilities with elderly users	ASSE 1016 Type T/P, CSA B125	
	HydroGuard® e427/428 Series Thermostatic	High-capacity thermostatic for therapy tubs, sitz baths, multiple showers	ASSE 1016 Type T, CSA B125 ASSE 1069	
	HydroGuard® T/P e700 Series Combination	Affordable T/P technology brings maximum safety to all budgets and facility types	ASSE 1016 Type T/P, CSA B125	
	Biltmore 900 Pressure Balancing	Pressure protection for multi-family housing, hotels and motels	ASSE 1016 Type P, CSA B125	
	HydroGuard® 410 Series Pressure Balancing	Pressure protection for heavy use areas, such as health clubs, locker rooms, correctional facilities	ASSE 1016 Type P, CSA B125	
Shower Shut Down Device	HydroGuard® HT115	High temperature shutoff device can be installed on any shower arm	ASSE 1062, CSA B125	
Lavatory Tempering	HydroGuard® T/P e420 Series Combination	Single or multiple low-flow lavatory	CSA B125 ASSE 1070	
	HydroGuard® T/P e480 Series Combination	Single or multiple low-flow lavatory	CSA B125 ASSE 1070	
	HydroGuard® LM495 Thermostatic	Single or multiple lavatory tempering	ASSE 1069 ASSE 1070, CSA B125	
	HydroGuard® XP ES150	Eye wash and eye/face wash with by-pass	ASSE 1071	
Emergency Fixture Tempering	HydroGuard® XP ETV200	Drench shower or multiple eye/face wash with by-pass	ASSE 1071	
	HydroGuard® XP ETV400	Multiple drench shower or combination units with by-pass	ASSE 1071	
	HydroGuard® XP ETV500	Multiple drench shower or combination units with by-pass	ASSE 1071	
Surface Mounted Shower Systems	HydroPanel II™ Series 450	Stainless steel paneled showers for buildings with no in-wall piping	ASSE 1016 Types T/P▲, P▲ and CSA B125	
Water Conservation	MeterOne™ Faucet Series	Self-closing single hole, and 4" center set for public restrooms, schools	ASME A112.18.1M, CSA B125	



A Comparison of ASSE 1062, 1069, 1070 and 1071 with revised 1016 and 1017 standards.

ASSE Standards

Standard	ASSE 1016 - 2005	ASSE 1017 - 2003
Status	Current	Current
Title	Automatic Compensating valves for individual showers and tub-shower combinations	Temperature-Activated Mixing Valves for hot water distribution systems
Category	Point-of use, bather or bather attendant interface	Tempered water distribution
Application	Shower or tub-shower combination only	Hot water source/boiler
Types	Type P - Pressure Balancing, Type T - Thermostatic, Type T/P - Combination	Thermostatic only
Valve Temp Range - Outlet	Full cold to 105°F minimum, 120°F maximum	Minimum adjustable range 105°F - 120°F
Temperature Tolerance	T/P and P = ±3.6°F T = +5.4°F, -9.0°F	±3°F to ±7°F (depending on valve size/capacity)
Pressure Change Test (Hot & Cold)	P = 50% up/down T = 20% up/down T/P = 50% up/down	No pressure change test
Temperature Change Test (Hot)	P = Does not test for temperature change T = 25°F hot water increase T/P = 25°F hot water increase	25°F hot water increase
Flow Test	Minimum 2.25 gpm	Not applicable
Minimum Tested Flow to Provide Control	2.5 gpm	50% of flow at a 10psid
Cold Water Failure Allowance	P, T, T/P < 0.5 gpm within 5 seconds before 120°F	Not applicable
Life Cycle	100,000 cycles – all	Not applicable
Applicable Powers Products ~some products undergoing ASSE listing process	e700 Type T/P - bath & shower e420 Type T/P - bath & shower e427 Type T - high capacity bath & shower e428 Type T - high capacity bath & shower 900 Type P - bath & shower 410 Type P - bath & shower	MM430 Series - Master Mixing Valves LM490 Series for multiple lavatories SH1430 Single Valve Hi/Los Powerstation▲ Supply Fixtures▲ Hi/Los-Multi-valve▲ Lead Free* LFMM430, LFSH1430 and LFLM490

* The wetted surface of this product contacted by consumable water contains less than one quarter of one percent (0.25%) of lead by weight.

ASSE 1062 - 2006	ASSE 1069 - 2005	ASSE 1070 - 2004	ASSE 1071 - 2008
Current	Current	Current	Current
Temperature-Actuated, Flow Reduction valves for individual fixture fittings (TAFR)	Automatic Temperature Control Mixing Valves	Water Temperature Limiting Devices	Temperature-Activated Mixing valves for plumbed emergency equipment
In-line high temperature limit devices	Point-of-use distribution Adjustment by installer	Point-of-use or distribution	Point-of-use or distribution
Faucets, shower heads, tub spouts dramatically reduce flow when temperature exceeds actuation point	Gang showers, sitz baths, spas, gang lavatories	Sinks, lavatories, baths	Eye washers, eye/face washes, drench showers and combination units
Thermostatic only	Thermostatic only	Thermostatic only	Thermostatic only
Not applicable	100°F - 115°F	105°F - 110°F	65°F - 95°F
Maximum actuation temperature 120°F or less	+ 5°F lasting more than 1.5 seconds within first 5 seconds - 9°F lasting more than 1 second within first five seconds	± 7°F	Varies depending on capacity. Also, hot water control has a tighter tolerance than cold water control.
Not applicable cold & hot supply	20% up and down for cold & hot supply	20% up and down for	Not applicable
Not applicable	25°F hot water increase	25°F hot water increase	25°F hot water increase
0.25 gpm within five seconds when temp. exceeds 120°F and one second once actuation temperature exceeds 129°F	Must be 90% of manufacturer's published flow	Must be 90% of manufacturer's published flow	HW Failure, CW flow = manufacturer's rated by-pass flow @ 30psid
Not applicable	2.5 gpm or less	Manufacturer's minimum stated flow	3.0 gpm or manufacturer's stated minimum
Not applicable 1.0 gpm for 1" devices and larger	0.5 gpm for 1/2" and 3/4" devices minimum flow, whichever	0.2 gpm or 20% of not to exceed 0.5 is greater before 120°F	CW failure, HW flow gpm
125,000 cycles	100,000 cycles	100,000 cycles	Not applicable
HT115	LM495 - lavatory Lead Free* LFLM485, 495	e420RB - Type T/P - lavatory e480 - Type T/P - lavatory LM495 - lavatory Lead Free* LFe480 and LFLM495	ES150 - Eye/face washes ETV200 - Drench showers ETV400 - Combination units ETV500 - Combination units



Distribution Valves and Systems

Master Tempering Valves - ASSE 1017

Thermostatically mix and control hot and cold water to deliver safe, blended water

HydroGuard^{XP} Master Tempering Valves

- ▶ Paraffin-based actuation technology responds dramatically to temperature fluctuations caused by changes in supply line temperature and pressure changes
- ▶ ASSE 1017 listed, CSA B125 approved
- ▶ Triple-duty checkstops with filtration screens and rotatable unions allow for horizontal and vertical mounting
- ▶ Available in rough bronze and polished chrome finish
- ▶ Lead Free models available



**SH1434
LFSH1434**

HydroGuard^{XP} Series SH1430 Single-Valve Hi/Lo

- ▶ Value engineered, single-valve does the work of two-valve manifold system
- ▶ Controls temperature for flows as low as 1.0 gpm (to ASSE 1017) and in excess of 200 gpm
- ▶ Features Powers patented "expandable restrictor" that directs maximum water flow across the actuator - even in low flow conditions

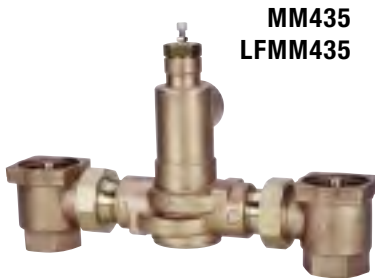

**MM435
LFMM435**

HydroGuard^{XP} Series MM430 Master Mixers

- ▶ The industry workhorse with over 50 years of reliability and unparalleled performance
- ▶ Available in five sizes up to 208 gpm to meet all requirements



*AquaSentry2
High Temperature Alarm*

4600150

Manifolded Tempering Stations - ASSE 1017

When high and low capacity demand is required



Installer Friendly, Self-Contained
 Water Tempering and Recirculation Stations

- ▶ Fully assembled and tested system. Designed to save time, money and call backs during set-up and installation
- ▶ Mounted on heavy-duty welded struts for fast, easy installation
- ▶ Standard features include ASSE 1017 listed and CSA B125 approved valves, return line with recirculation pump, pressure/temperature gauges, GFCI outlet and ball valves
- ▶ Exclusive by-pass loop allows for fast easy set up. No need to wait for water circulate throughout the building to set system temperature
- ▶ Optional features include automatic balancing valve, aquastat and temperature alarm
- ▶ Lead Free models available

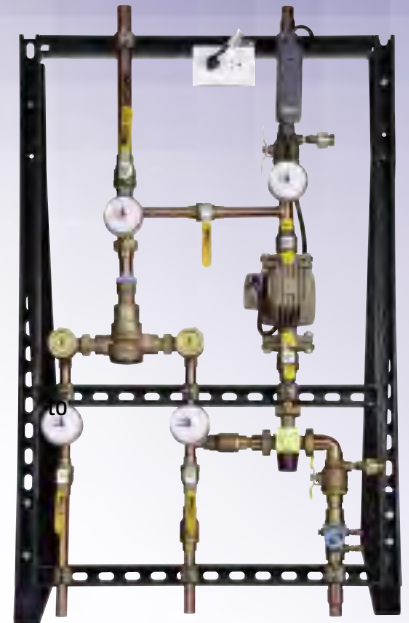

PowerStation

HydroGuard® Multi-Valve Hi/Lo Systems

- ▶ Fully assembled and tested water tempering stations
- ▶ Feature ASSE and 1017 listed tempering valves with paraffin-based actuation technology
- ▶ Systems include PRV, pressure/temperature gauges, triple-duty checkstops and ball valves
- ▶ Control from as little as 0.5 gpm to 850 gpm
- ▶ Lead Free models available

HydroGuard® Series LM490, MM430 & SH1430 Supply Fixtures

- ▶ Includes ASSE 1016 or 1017 thermostatic tempering valve, union inlet-strainer checkstops, dial thermometer, valve control, shutoff valve and interconnecting piping
- ▶ Optional equipment includes cabinets (recessed, semi-recessed or wall mount), cold water by-pass and vacuum breaker
- ▶ Lead Free* models available



MM432AENS600



SH1432HLAEM00



* The wetted surface of this product contacted by consumable water contains less than one quarter of one percent (0.25%) of lead by weight.



Emergency Tempering Solutions

Emergency Tempering with Bypass - ASSE 1071

Deliver safe, tempered water to Eye/Face Wash, Drench Showers and Combination Units

es150



ETV200



ETV400



ETV500



HydroGuard® XP Series

- ▶ Features patented internal bypass that provides substantial flow in the event of hot water failure
- ▶ Ensures uninterrupted flow of flushing fluid in the event of hot water loss or actuator failure
- ▶ Paraffin-based actuation technology provides greater force than conventional elements resulting in superior control for improved safety
- ▶ Tamper resistant temperature adjustment includes locking mechanism to insure unauthorized set point readjustment
- ▶ ASSE 1071 listed

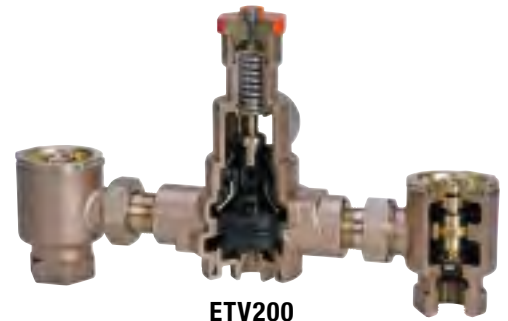

ETV200



Advanced Thermal Actuation

Industrial Valves and Controllers

A Complete Line of Self-Operating and Pneumatically Actuated Valves and Mechanical Controllers for Tempering and Industrial Processes

#11 Self Operating Temperature Regulators

- ▶ Interchangeable sensing and control components for minimum downtime, greater flexibility and added economy
- ▶ Open yoke design minimizes heat transfer from valve to bellows
- ▶ Setting scale provides easy, convenient reference when changing set points
- ▶ Large (7.8 in²) bellows provides extra valve positioning power
- ▶ Wide range of heating, cooling and mixing valve bodies available



595

FLOWRITE II[®] Heavy Duty Globe Control Valves

- ▶ Heavy duty bronze and iron bodies
- ▶ Designs to meet 1/2" - 6" steam and water modulating, mixing or bypass applications
- ▶ Multiple packing choices - spring loaded
- ▶ Stainless steel hardware and actuator mounting accessories
- ▶ Field reversible 46 in² and 100 in² pneumatic diaphragm actuators available



593



596/597

ACCRIEM[®] Rigid and Remote Bulb Blind Controllers

- ▶ Precise, rapid response to temperature changes by sending a proportional pneumatic signal to the control valve
- ▶ Supply and pressure control gauges included
- ▶ Rugged, non-indicating construction is unaffected by moisture or dust
- ▶ Trouble-free operation - simple design with few moving parts
- ▶ Air or water operated



744-1213

744-1256



Bath & Shower Solutions



e707

Combination Tempering - ASSE 1016, Type T/P

Affordable T/P protection against pressure and temperature changes

HydroGuard® T/P

Series e700 Combination Tempering Valve - ASSE 1016, Type T/P

- ▶ The first *affordable* T/P combination shower valve that allows distribution of higher hot water temperatures, minimizing the risk of Legionella while protecting bathers against unsafe water temperatures
- ▶ Does not require seasonal adjustment of handle rotation stop common to pressure balancing valves
- ▶ Solid brass construction features 4 gpm capacity (at 45psid) and corrosion resistant internal components that will not stick or seize
- ▶ Self-contained cartridge simplifies maintenance and retrofits into Biltmore pressure balancing valves (model 3)
- ▶ ASSE 1016, Type T/P, and cUPC listed
- ▶ Ideal for hospitals, nursing homes, assisted living facilities or anywhere those with diminished physiological, mental and emotional capacities are resident
- ▶ 5-year limited warranty on internal tempering mechanism
- ▶ Simple back-to-back installation without cross-connecting pipes



e700 Series



e705



e710J101Y0



e705M1S000



e707J1S000

Combination Tempering - ASSE 1016, Type T/P

Institutional grade construction, high-capacity output with over 40 years of dependable service

HydroGuard® T/P

Series e420 Combination Tempering Valve - ASSE 1016, Type T/P

- ▶ T/P combination shower valve allows distribution of higher hot water temperatures, minimizing the risk of legionella while protecting bathers against unsafe water temperatures
- ▶ Guards against both pressure and temperature changes, meeting the most stringent requirements of ASSE 1016 - Type T/P
- ▶ Does not require seasonal adjustment of handle rotation stop common to pressure balancing valves
- ▶ Solid brass construction features 5.0 gpm capacity (at 45psid) and corrosion resistant internal components that will not stick or seize
- ▶ Self-contained cartridge simplifies maintenance and retrofits into HydroGuard® 420 valves dating back to 1960
- ▶ Ideal for hospitals, nursing homes, assisted living facilities - anywhere those with diminished physiological, mental and emotional capacities are resident
- ▶ High capacity models e427 and e428 are ideal for sitz baths, therapy tubs and multi-head showers (14 gpm @ 45psid). Listed ASSE 1016, Type T



e423



e425



e420S22
Coming
Soon



e420 paraffin upgrade kit for valves dating back to 1960



420 451

e426AM2U6Y0

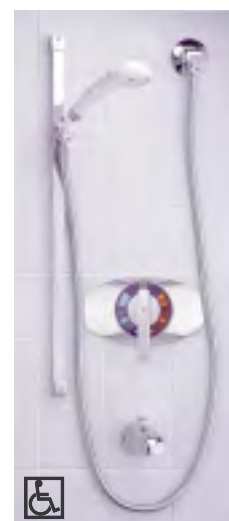

e426A00U700



Bath & Shower Solutions

Pressure Balancing - ASSE 1016, Type P

A legacy of bather protection since 1929. Powers Type A mixer earned first pressure balancing patent



P905

P902

Biltmore

Series 900 Pressure Balancing Valve

- ▶ Affordable protection against pressure fluctuations within a plumbing system
- ▶ Reliable poppet/diaphragm design won't stick or seize like piston/sleeve type valves
- ▶ Cast integral checkstops prevent cross flow and simplify maintenance
- ▶ Simple back-to-back installation without cross-connecting pipes
- ▶ Shallow wall design installs in as little as 2" wall depth
- ▶ ADA compliant activation and configurations
- ▶ ASSE 1016, Type P and cUPC listed

HT115



HydroGuard®

Series HT115 High Temperature Flow Reduction Device

- ▶ Thermostatically shuts off water if temperature reaches 115°F (46°C)
- ▶ Ideal for pressure balancing and mechanical mixing valves
- ▶ Installs in minutes with no special tools
- ▶ ASSE 1062 listed

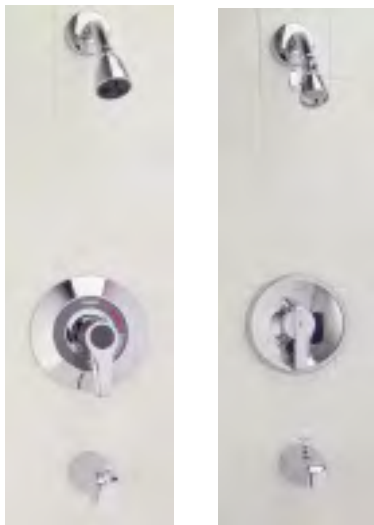

P905HJ1U

P902HKIS



Pressure Balancing - ASSE 1016, Type P

HydroGuard®

Series 410 Pressure Balancing Valve

- ▶ Rugged bronze construction for heavy use applications like health clubs, schools and light security correction facilities
- ▶ Reliable poppet/diaphragm design won't stick or seize like piston/sleeve type valves in harsh water
- ▶ Concealed and exposed versions available
- ▶ ADA compliant activation and configurations
- ▶ ASSE 1016, Type P compliant, CSA B125 approved

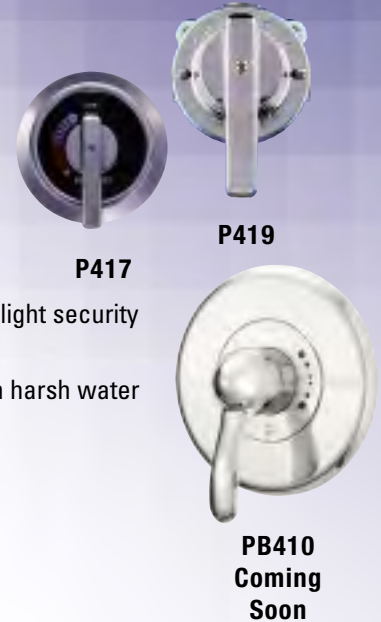

VisuGuard® LCD

Series F727 Combination Tempering Valve - ASSE 1016, Type T/P

- ▶ Integral 1" LCD temperature display in °F or °C
- ▶ Single AAA battery provides up to four years of service
- ▶ Water tight enclosure protects electronics behind Lexan lens
- ▶ Back to back installation without costly cross over piping
- ▶ Precise temperature display within 1/10th
- ▶ ASSE 1016, Type P and cUPC listed



F727

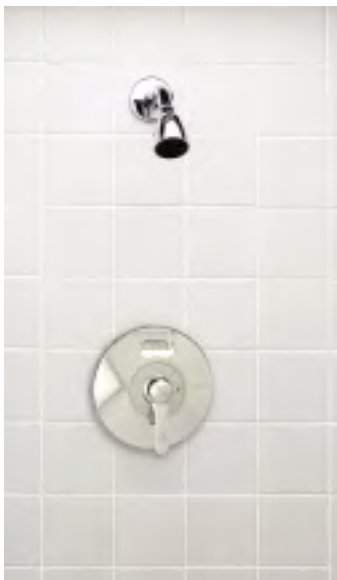

F727AM1000

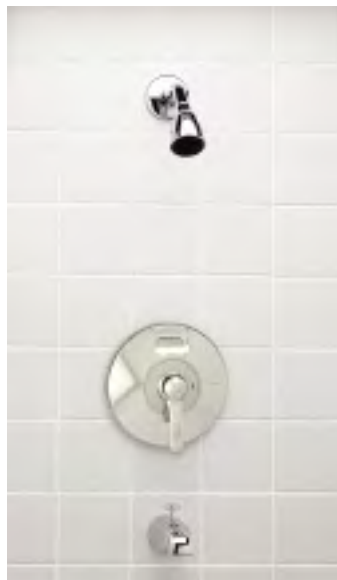

F727AM1T00

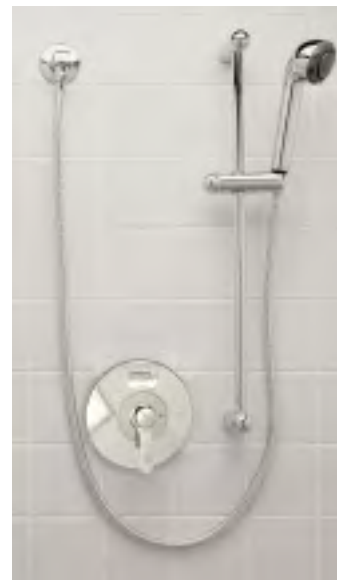

F727A00090



Bath and Shower Solutions

Surface Mounted Shower

Available with all Powers Series Point-of-Use Tempering Valves - ASSE 1016, Types T/P and P



4507054



4507100

HydroPanel II™ Surface Mounted Shower Systems.

- ▶ Ideal for installations where in-wall piping doesn't exist or may be impractical such as schools, health clubs and light security correctional facilities
- ▶ Single unit stainless steel panel allows easy access to concealed components
- ▶ Vandal-resistant fasteners prevent tampering
- ▶ Modular design allows all vertical and horizontal piping to be concealed with standard components

HydroPanel II™ Series e700 - ASSE 1016, Type T/P

- ▶ Maximum protection against pressure and temperature changes utilizing Powers exclusive series e700 combination valves
- ▶ Tempering valves ASSE 1016, Type T/P and cUPC listed

HydroPanel II™ Series e420 - ASSE 1016, Type T/P

- ▶ Maximum protection combined with rugged construction and greater flow
- ▶ Tempering valves ASSE 1016, Type T/P compliant and CSA B125 approved

Biltmore Series 900 - ASSE 1016, Type P

- ▶ Powers most specified system protects against dangerous pressure swings
- ▶ Tempering valves ASSE 1016, Type P and cUPC listed

HydroPanel II™ Series 410 - ASSE 1016, Type P

- ▶ Powers rugged, high capacity, pressure balance option
- ▶ Tempering valves ASSE 1016, Type P compliant and CSA B125 approved



4504103



4504002

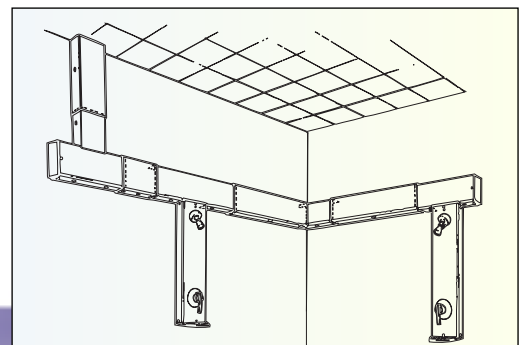

Lavatory Tempering & Hot Water Solutions

Blended and Hot Water Tempering - ASSE 1070

Superior low flow protection for infrared, single-handle, two-handle and metering faucets

TempTAP™ Series 105, 115, 205 and 215
 Thermostatic Lavatory Faucets - ASSE 1070

- ▶ Thermostatic tempering built inside the faucet
- ▶ ASSE 1070 and IAPMO cUPC listed
- ▶ NSF 61 Section 9 Annex G approved for Lead Free
- ▶ ADA compliant
- ▶ Integral check and filters



HydroGuard® T/P e480 and LFe480 Lavatory Tempering - ASSE 1070 Type T/P

- ▶ Allows facility to distribute water at higher temperatures, minimizing the potential occurrence of Legionella and other known bacteria while protecting against unsafe water temperatures
- ▶ Integral checks with filtration screens standard
- ▶ ASSE 1070 listed, CSA B125 certified
- ▶ Tamper-resistant temperature adjustment with locking mechanism from 80 - 120°F (27 - 49°C)



e480

HydroGuard® T/P e420 Lavatory Tempering - ASSE 1070

- ▶ Higher capacity tempering to 5.5 gpm
- ▶ ASSE 1070 listed at flows as low as 0.5 gpm
- ▶ 5°F (2.8°C) approach temperature



e420RB

HydroGuard® Series LM495 and LFLM495 Lavatory Tempering ASSE 1069 & ASSE 1070

- ▶ Powers highest capacity lavatory tempering valves for multiple lavatories and hot water heaters in flows from 12 gpm
- ▶ 1/2", 3/4" and 1" sizes with union connections - Sweat, NPT, CPVC & PEX, Quick-Connect
- ▶ Adjustable temperature selection with locking mechanism
- ▶ Integral checks with filtration screens are standard
- ▶ Series LM495 - ASSE 1069, 1070 and UPC listed, CSA B125 approved
- ▶ Lead Free* models available



LM495



* The wetted surface of this product contacted by consumable water contains less than one quarter of one percent (0.25%) of lead by weight.



Specialty Products

Tempering and Control Providing Engineered Solutions for Commercial Applications



Series 460 Alarm System

- ▶ Use in tandem with all Powers master tempering valves, Hi/Lo valves systems and PowerStations.
- ▶ Provides audible and visible alarm when temperature exceeds high or low set points.
- ▶ Can be used in conjunction with a solenoid valve to shut down water when temperature limit is exceeded.



**460-0150
AquaSentry**

METER One™ Self-Closing Faucet Series

- ▶ Available in single-hole and 4" centerset configurations.
- ▶ Patented, self-cleaning design flushes out contaminants making valve virtually "clog" proof.
- ▶ ADA - handicap compliant activation.



**P1005
Meter One**



PressureGuard™ Balancing Valve

- ▶ Adds pressure balancing protection to standard two-handle or single-lever mechanical shower valves.



**4100063
PressureGuard**



**P1815
Meter One**



HydroGuard® ESP Electronic Shower Systems

- ▶ Infrared of Piezo technology delivers tempered water in vandal prone areas.
- ▶ Adjustable timing and lock-out features prevent tampering and abuse.
- ▶ ADA compliant operation, UL, CSA approved power source.



450-100IC03WD

001 SAFETY 1101 RELIABILITY 0101000 EFFICIENCY 110
001 SAFETY 1101 RELIABILITY 0101000 EFFICIENCY 1101 COMPLIANCE 011



0000111 SAFETY 000011110001111010101000011110000001111
1000000111110000111 RELIABILITY 000011110001111010101000
1101010100001111000000111110000111 EFFICIENCY 000011110
11110000111 COMPLIANCE 0000111100011110101010000111100
100001111000000111110000111 PERFORMANCE 00001111000111

POWERS™

A Watts Water Technologies Company

**ISO 9001-2008
CERTIFIED**

USA: Phone: 1.800.669.5430 • Fax 1.847.229.0526 • www.powerscontrols.com
Canada: Phone: 1.888.208.8927 • Fax 1.888.882.1979 • www.powerscontrols.ca