

Blue-White®

Industries, Ltd. **FLEXFLO® Peristaltic Metering Pumps**
Engineering and Technical Data

A-100NC

Fixed Speed

Dial Knob Control

5 second cycle timer



Features:

- Peristaltic pump design does not have valves that can clog requiring maintenance.
- Self priming - even against maximum line pressure. By-pass valves are not required. Cannot vapor lock or lose prime.
- Outputs to 5.17 GPH (19.56 LPH).
- Output pressures to 100 PSI (6.9 bar).
- Output volume is not effected by changes in back pressure.
- Patented pump tube design installs easily and stays centered on the rollers without manual adjustment.
- Two pump tubes supplied with each pump. No extra tubing required.
- Easy to use dial knob output control.
- 20:1 turndown ratio.
- Adjustable 5 second repeating interval timer. 0.25 - 5.0 second adjustable on time per 5 second cycle.
- Built-in Tube Failure Detection system (TFD). Senses chemical in the pump head, shuts off the pump and activates an NPN open collector output.
- Compatible with Blue-White's output flow verification sensor system.
- Durable housing of chemical resistant Valox (PBT) thermoplastic.

Specifications:

Max. working pressure:100 psig (6.9 bar)

Max. fluid temperature:130° F (54° C)

Max. ambient temperature: ..14° to 110° F/ -10° to 43° C

Output adjustment range:5-100%

Duty cycle:.....Continuous

Maximum viscosity:5,000 Centipoise

Maximum suction lift:30 ft. Water 0 psig

Maximum Solids:50% by volume

Enclosure:NEMA 3R, (IP23)

Approximate shipping wt: ...10 lb. (4.5 kg)

Voltage (max amp):115VAC/60Hz, 14 & 30 rpm = 1.37 amp
 45 & 60 rpm = 1.87 amp
 230VAC/60Hz, 14 & 30 rpm = 0.64 amp
 45 & 60 rpm = 0.74 amp
 220VAC/50Hz, 14 & 30 rpm = 0.68 amp
 45 & 60 rpm = 1.14 amp
 240VAC/50Hz, 14 & 30 rpm = 0.66 amp
 45 & 60 rpm = 1.04 amp

Power Cord Plug Type:.....115V60Hz = NEMA 5/15 (USA)
 230V60Hz = NEMA 6/15 (USA)
 220V50Hz = CEE 7/VII (EUROPE)
 240V50Hz = CEE 7/VII (EUROPE)

Materials of Construction:

Wetted components:

Pump Tube Assembly:.....Norprene®, Tygothane® or Viton® tubing
 PVDF tube assembly connection fittings

Suction Tubing:.....Clear PVC

Suction Strainer:Natural Polypropylene

Discharge Tubing:.....Natural Polyethylene (LLDPE)

Injection/Check valve:

Body & insert:Polypropylene (optional PVDF)

Check Ball:Ceramic

Spring:Hastelloy C-276

Ball Seat O-ring:.....TFE/P (optional EP)

Static Seal O-ring:Viton® (optional EP)

Non-Wetted components:

Pump Head & Enclosure:Valox® (PBT) thermoplastic

Pump Head Cover:.....Clear PVC

Cover Screws:300 Stainless, Polypropylene cap

Roller Assembly:

Rotor:.....Valox® (PBT)

Rollers:Nylon

Roller Bearings:Bronze

Motor Shaft:.....Nickel plated steel

TFD System Sensor pins:Hastelloy C-276

Power Cord:3 conductor, SJTW-A Water-resistant

Blue-White Industries, Ltd. FLEXFLO® Peristaltic Metering Pumps

Dimensions:

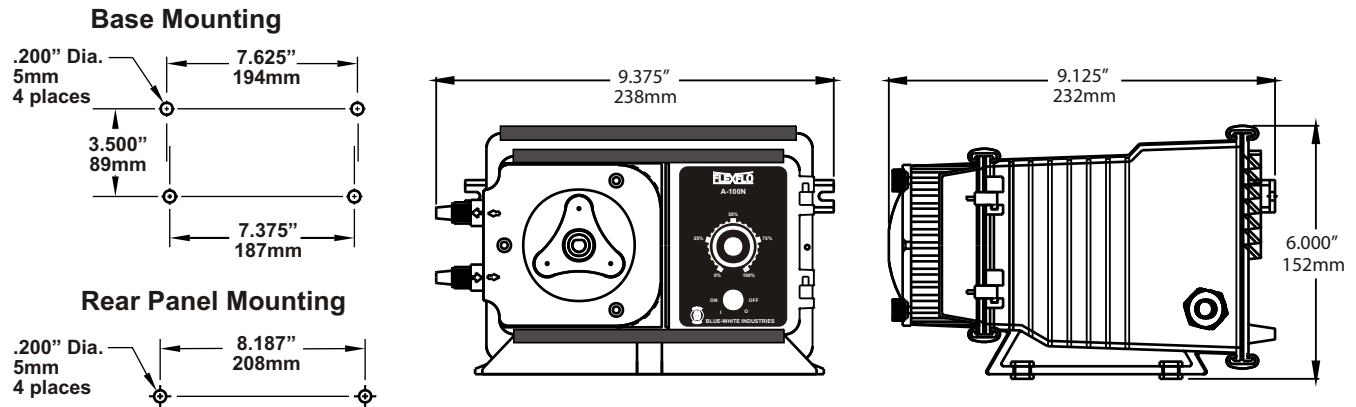

Model Number Matrix:

MODEL A1N **C** - -

Maximum Motor RPM 0 = 14 RPM 1 = 30 RPM 2 = 45 RPM 3 = 60 RPM	Miscellaneous Options (not required) 1 = T140-6V injector replaces A-014HD-6A 2 = C-340V footvalve replaces C-342-6 strainer 5 = A-014HDK-6A injector PVDF T7 = 7 gallon chemical tank system T15 = 15 gallon chemical tank system T30 = 30 gallon chemical tank system
Power Supply 0 = 115V60Hz 1 = 220V50Hz 2 = 230V60Hz 8 = 240V50Hz	Tubing Connection Type T = Compression tube nuts Q = Push-on quick connect
Output Control C = Analog timer, 5 sec. Cycle - 100% duty A = Analog timer, 60 sec. Cycle - 100% duty S = Analog timer, 60 sec. Cycle - 10% duty V = Digital speed control with external input F = Analog speed control E = Digital batch timer with external input Z = Proportional feed system - JBox/Cord X = No output control - fixed feed rate	Pump Tube Size and Material 1 = 1/4" OD Tygothane 2 = 3/8" OD Tygothane 3 = 7/16" OD Tygothane 4 = 1/4" OD Norprene 5 = 5/16" OD Viton 6 = 3/8" OD Norprene 7 = 7/16" OD Norprene

Maximum Flow rate and pressure capacities:

Tube no.	Tubing Material	14 RPM MODELS					30 RPM MODELS					45 RPM MODELS					60 RPM MODELS				
		ml/m	oz/m	lph	gph	PSI(bar)	ml/m	oz/m	lph	gph	PSI(bar)	ml/m	oz/m	lph	gph	PSI(bar)	ml/m	oz/m	lph	gph	PSI(bar)
1	Tygothane	15	0.51	0.90	0.24	65(4.5)	35	1.18	2.10	0.55	65(4.5)	54	1.83	3.24	0.86	65(4.5)	67	2.26	4.02	1.06	65(4.5)
2	Tygothane	32	1.08	1.92	0.51	65(4.5)	75	2.54	4.50	1.19	65(4.5)	115	3.89	6.90	1.82	65(4.5)	140	4.73	8.40	2.22	65(4.5)
3	Tygothane	73	2.47	4.37	1.16	50(3.5)	173	5.85	10.38	2.74	50(3.5)	261	8.82	15.66	4.14	50(3.5)	326	11.01	19.56	5.17	50(3.5)
4	Norprene	6	0.20	0.36	0.10	100(6.9)	13	0.44	0.78	0.21	100(6.9)	21	0.20	1.26	0.10	100(6.9)	25	0.85	1.50	0.40	75(5.2)
5	Viton	11	0.37	0.66	0.17	25(1.7)	26	0.88	1.56	0.41	25(1.7)	39	1.31	2.34	0.62	25(1.7)	48	1.62	2.88	0.76	25(1.7)
6	Norprene	18	0.61	1.08	0.29	100(6.9)	42	1.42	2.52	0.67	100(6.9)	63	2.13	3.78	1.00	100(6.9)	79	2.67	4.74	1.25	75(5.2)
7	Norprene	57	1.92	3.42	0.90	50(3.5)	138	4.66	8.28	2.19	50(3.5)	200	6.76	12.00	3.17	50(3.5)	250	8.45	15.00	3.96	50(3.5)

* NOTE: 50Hz units deliver 20% less output.
Gallons shown are U.S. Gallons

Replacement Pump Tubes:

Pump Model Number Suffix	Pump Tube Part Number	Pump Tube Material	Nominal Pump Tube OD
-1T	A-002N-1T	Tygothane	1/4" (6,4mm)
-2T	A-002N-2T	Tygothane	3/8" (9,5mm)
-3T	A-002N-3T	Tygothane	7/16" (11,1mm)
-4T	A-002N-4T	Norprene	1/4" (6,4mm)
-5T	A-002N-5T	Viton	5/16" (7,9mm)
-6T	A-002N-6T	Norprene	3/8" (9,5mm)
-7T	A-002N-7T	Norprene	7/16" (11,1mm)
-1Q	A-002N-1Q	Tygothane	1/4" (6,4mm)
-2Q	A-002N-2Q	Tygothane	3/8" (9,5mm)
-4Q	A-002N-4Q	Norprene	1/4" (6,4mm)
-6Q	A-002N-6Q	Norprene	3/8" (9,5mm)