

BUTTERFLY VALVES

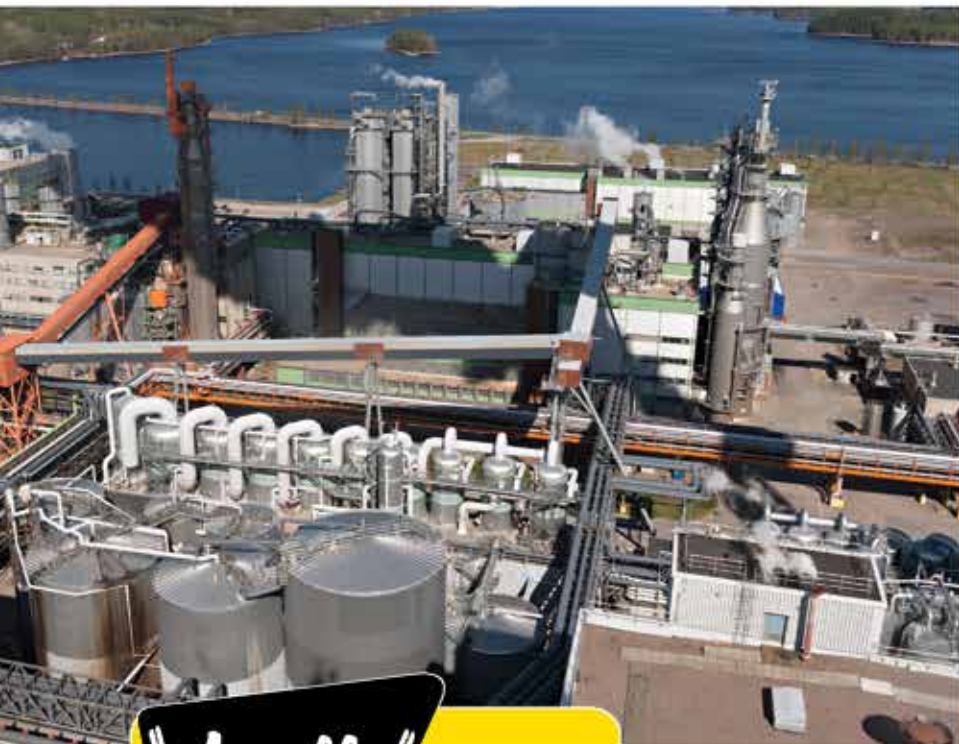

"Apollo" Valves





"Apollo" Valves

A history of Quality, Service and Innovation

Now in its ninth decade, Conbraco Industries, Inc. is a leading manufacturer of flow control products for U.S. and international markets. The company's headquarters is based in Matthews, North Carolina with manufacturing plants and foundries located in Pageland and Conway, South Carolina.

Conbraco has a history of new product development and innovation that dates back to the company's inception in 1928. Today, the Conbraco line of products is marketed under the "Apollo Valves" brand and includes: ball valves, butterfly valves, backflow prevention devices, water pressure reducing valves, mixing valves, safety relief valves, water gauges, strainers, vacuum breakers, valve actuators and more.

Conbraco's vertically integrated manufacturing ensures a consistency of production, testing, quality and availability. It's your assurance that Conbraco flow control products will deliver long term performance advantages. All manufacturing facilities are ISO 9001:2008 certified.

The Conbraco line continues to expand - with new products, designs and advanced materials - to better serve the needs of our customers in the chemical processing, pulp and paper, petroleum, residential and commercial plumbing and heating markets, as well as manufacturing and other markets.



PAGELAND, SC
Bronze Foundry and Manufacturing Plant



PAGELAND, SC
Final Assembly and Distribution Center



CONWAY, SC
Steel Foundry and Manufacturing Plant



MATTHEWS, NC
Corporate Headquarters

Apollo® and Apollo International™ iron bodied butterfly valves offer an economical, bubble-tight shut-off design that's ideal for use in commercial HVAC and plumbing as well as irrigation and select industrial applications. These valves are rated to 200 psig in sizes 2" through 12" and 150 psig in sizes 14" and larger. Apollo® and Apollo International™ butterfly valves are available with a variety of options and are easily automated.

TABLE OF CONTENTS

General Purpose Butterfly Valves – 141 Series & 145 Series	Options	5
Advantages	Applications	6
Parts List	Installation	7
Specification	Contractor Grade Butterfly Valves – 149 Series	12
Dimensions.....	How to Order Butterfly Valves	13
Operating Torque	Double Offset High Performance Butterfly Valves	14
Cv Data	Warranty	14

BUTTERFLY VALVES

General Purpose Butterfly Valves – 141 Series & 145 Series

Item	Description	Material
1	Body	Ductile Iron ASTM A536 (65-45-12)
2	Seat	EPDM* --- or --- Buna-N (Nitrile)* --- or --- Viton®B*
3	Shaft	416 Stainless Steel ASTM A564
4	Disc	Nickel Plated Ductile Iron ASTM A536 (65-45-12) --- or --- Aluminum-Bronze ASTM B148, C95400 --- or --- 316 Stainless Steel A STM A351, Type CF8M
5	Bushing	Glass Reinforced Epoxy
6	Weather Seal	Buna-N
7a	Retainer	Steel with Protective Finish
7b	Retainer	Steel with Protective Finish
8	Washer	Brass
9	Set Screws (Flat Point)	Steel with Protective Finish
10	Set Screws (Cone Point)	Steel with Protective Finish
11	Nameplate	

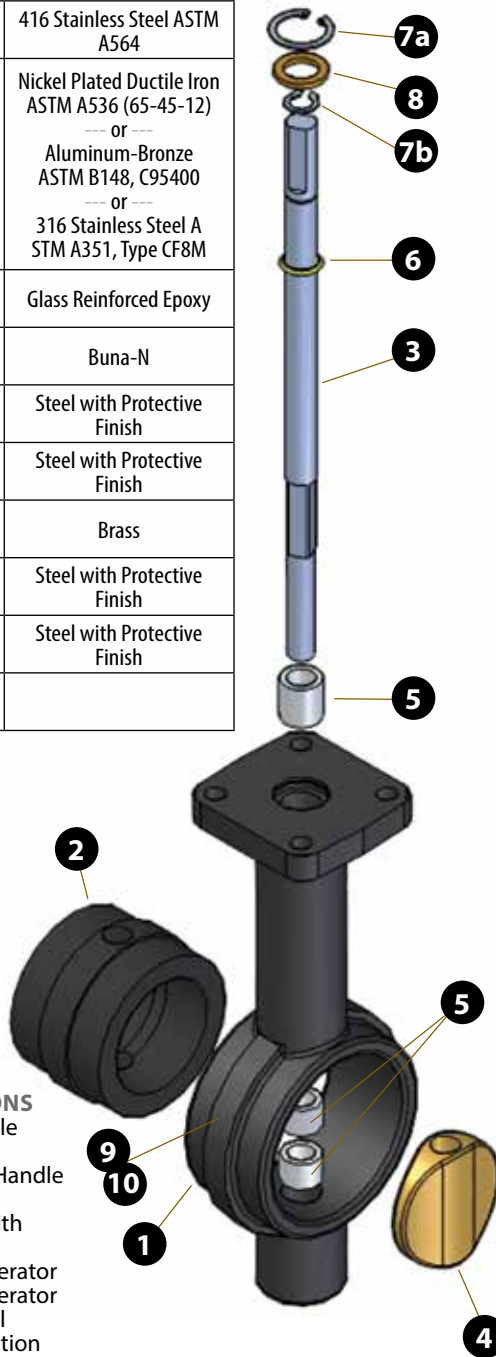

AVAILABLE OPTIONS

- 10 Position Handle
- Gear Operator
- Infinite Position Handle
- Locking Handle
- Gear Operator with Chain Wheel
- Locking Gear Operator
- Locking Gear Operator with Chain Wheel
- Pneumatic Actuation
- Electric Actuation

Exploded View
WD141 – Wafer Design Shown

Apollo International™

- **WD141:** One-piece wafer-style, sizes 2" to 12"
- **LD141:** Lug valves, sizes 2" to 24"

Apollo Assembled & Tested in USA

- **WD145:** One-piece wafer-style, sizes 2" to 12"
- **LD145:** Lug valves, sizes 2" to 12"

Certification

- Certified to NSF/ANSI 372 Lead Free.
- Registered under Canadian Registration Number CRN# 0C12102.8CL.

Body Design

- Ductile Iron ASTM A536
- WD Model: a one-piece wafer design with flange locating holes in larger sizes (8" to 12")
- LD Model: valves are full lug with tapped lugs, to ANSI 125/150 drilling. Face-to-face dimensions meet universal interchangeability standards outlined in MSS SP-67 and API 609.
- Models come equipped with an extended neck providing at least 2" clearance between the valve top plate and pipe flange to allow ease of insulation installation.

Blowout Proof Seat with Molded in Stiffener Ring

- Valves are equipped with a stretch-resistant, non-collapsible blowout-proof seat.
- Phenolic Stiffener Ring (2"-12")
- Aluminum Stiffener Ring (14"-24" LD141 only)

Seat – No Gaskets Required

- Seat design eliminates the need for flange gaskets.
- Installs between standard ANSI 125/150 flanges.

Mounting Flange For Actuator

- ISO 5211 standard cast-in top plate
- Designed to dimensions for easy mounting of Apollo® actuators and manual operators.

Through Shaft

- Assures positive disc positioning and dependable performance.

Weather Seal

- Shaft equipped with weather seal to prevent external media from entering the shaft bore.

Square Shaft-to-Disc Connection

- Provides a robust shaft-to-disc connection without pins or bolts. Easy maintenance.

Three Bushings

- Supports shaft at three locations to enhance shaft alignment and absorb actuator side thrusts.

Profiled Disc Design

- Precision disc assures bubble-tight shut-off with minimal torque and longer seat life.

Shaft Seal

- The shaft diameter is greater than the diameter of the seat's shaft hole creating a robust shaft seal.
- The stiffening ring molded into the seat guards against distortion, a frequent cause of shaft leakage.

End of Line Service

- All LD Model valves are equipped with retainer screws for dead end service; 2" through 12" to 200 psig
- Testing: All valves are 100 percent factory tested before shipping.

Silicon Free Option (145 Series)

Testing: 100 percent factory tested before shipping

BUTTERFLY VALVES

Specifications – 141 Series & 145 Series

DESIGN SPECIFICATIONS

- WD (ductile iron, wafer body design)
LD (ductile iron, single flange, lug body design)
- Designed to fully comply with MSS SP-25, MSS SP-67, and API 609
- Meets the intent and passed AWWA C-504 Section 5* proof of design tests
- New for Late Spring 2014: Product will comply with NSF/ANSI 372 and with lead content requirements for "lead free" plumbing as defined by the U.S. Safe Drinking Water Act effective January 4, 2014. Consult factory for availability.
- Extended neck to allow up to 2" of insulation
- Dead-End Service: Lug style valves are suitable for end of line service to their rated pressure without the use of a downstream flange (2" - 12" only)
- Ideal for ON/OFF and throttling service
- Designed for extended service with minimal wear and maintenance. No regular lubrication is necessary
- Compatible with ASME Class 125 and Class 150 weld neck or slip-on flanges
- Larger wafer body design includes four alignment holes 8" to 12" (DN200 to DN300) WD models
- Polyester Body Coating:
 - Resistant to ultra-violet radiation
 - Resists a broad range of chemicals including dilute acids, alkalis, solvents alcohols, greases, oils
 - Resists most impacts without chipping or cracking
- Cartridge Style Seat:
 - Isolates body and stem from the media
 - Provides mating flange seals eliminating the need for separate flange gaskets
 - Provides positive shut-off of line media at rated pressures
- EPDM and Buna-N (Nitrile) Seats are **Food Grade as standard**
- Profiled Disc design assures bubble-tight shut-off, minimal torque and longer seal life
- Double-D shaft drive 2" to 14" (DN50 - DN350)
Round and keyed shaft drive 16" to 24" (DN400 - DN600)
- Blow-out Proof Shaft
- Upper and lower shaft bearing ensure longer seat life and lower operating torque
- Actuator mounting flange (top plate) conforms to ISO 5211 which allows choice of lever operators, gears and direct mounting of many Apollo pneumatic and electric actuators

*Specification applies to 3" - 24" valves

SPECIFICATIONS

SIZE RANGE

141 Series: Apollo International™

WD141 (wafer body design): 2"-12" (DN50 - DN300)

LD141 (single flange body design): 2"-24" (DN50 - DN600)

145 Series: Assembled & Tested in USA

WD145 (wafer body design): 2"-12" (DN50 - DN300)

LD145 (single flange body design): 2"-12" (DN50 - DN300)

PRESSURE-TEMPERATURE RATING AT 100°F (37.8°C)

All Body, Disc, Seat Combinations

2"-12" (DN50 - DN300) 200 psi (13.8 bar)

14"-24" (DN350 - DN600) 150 psi (10.3 bar)

All Sizes – Vacuum Rating 29 inches of Hg (737 mm of Hg)

TEMPERATURE RATING - SEATS

EPDM -20° F to 250° F Intermittent,
225° F Continuous (-29° C to 107° C)

Buna-N (Nitrile) 10° F to 180° F (-12° C to 82° C)

Viton® B -20° F to 300° F (-29° C to 149° C)

FLANGE DRILLING

ANSI 125/150 Drilling Standard

• WD – wafer body design: 8" to 12" (DN200 to DN300)
include two alignment holes

TESTING

Every LD and WD is fully tested prior to shipment. Testing includes a body shell test, a seat test, and a cycling test to insure proper functioning of moving parts. Additional testing is also available. Please let us know your requirements.

SHUTOFF PERFORMANCE

Zero Leakage. Bi-directional, Bubble Tight. All Sizes

ANSI/FCI 70-2 establishes a series of six leakage classes for control valves and defines the test procedure. Class VI allows the least leakage. LD's and WD's are bubble tight, which exceeds Class VI requirements.



145 Series

BUTTERFLY VALVES

Options

The following options are available factory installed on any of the LD or WD Series Apollo Butterfly Valves.

The LC149 series are available either with the standard 10-position handle or with the optional gear operator on sizes 8" and larger. The other options may be purchased in kit form and installed by the user or distributor.

BARE STEM (MODEL CODE SUFFIX 0)

Select this suffix to specify a butterfly valve without a handle, gear operator or actuator.

TEN (10) POSITION HANDLE (SUFFIX 1)

The 10 position handle is the most common manual operator for valves 8" and smaller. (It can be specified on valves through 12" size.) The 10 position handle allows the valve to be set in any one of ten positions between fully open and fully closed (approximately 10 degree increments).



GEAR OPERATOR (SUFFIX 2)

Although the option is available for any size of valve, it is commonly used on valves larger than 6", and is the only manual option offered for valves 14" and larger. All gear operators feature a self-locking design preventing back driving of the gear and drifting in the disc's position. All gear operators are weather resistant and permanently lubricated. They are equipped with position indicators and adjustable travel stops.

INFINITE POSITION HANDLE (SUFFIX 3)

This option allows the valve to be set at any degree of open and is available for valves 2" through 12".

LOCKING HANDLE WITH 10 POSITION PLATE (SUFFIX 4)

The option adds a locking device to "suffix 1".

GEAR OPERATOR W/ CHAINWHEEL (SUFFIX 5)

A manual gear with chainwheel allows an overhead valve to be opened or closed from a location lower than the valve.

LOCKING GEAR OPERATOR (SUFFIX 7)

A manual gear with lock-out option allows the manual gear to be locked with a padlock.

LOCKING GEAR OPERATOR W/ CHAINWHEEL (SUFFIX 8)

Combination of both chainwheel operator (suffix 5) and the locking device (suffix 7) are also available to work in conjunction with the gear operators described under "suffix 2".

SELF LOCKING GEAR OPERATORS

Self locking manual gear operators are available for all Apollo® WD and LD Series butterfly valves for heavy duty ON/OFF and throttling service. Gear operators are completely weatherproof and self-lubricating; they're equipped with position indicators and adjustable travel stops. Chainwheel operators are available. **All units feature 12" handwheels** with gearing for each size to keep rim pull at 50# or less.

HANDLE AND NOTCH PLATE KITS

Handle and notch plate kits are supplied for manual operation, ON/OFF and throttling service. Kit provides positive disc position indication for 2" to 12" WD and LD Series butterfly valves. Locking handle and infinite position handle are also available.

APOLLO® ACTUATORS

Apollo® Actuators are available as double acting or as spring return and come with a wide variety of corrosion resistant coatings for use in most any application. Standard features include external travel stop adjustments, high temperature, low friction bearings and seals. Mounting kits are available for ease of installation.



Butterfly valves require pneumatic actuators with dual (open & close) limit stops.





BUTTERFLY VALVES

Applications

The Apollo® LD/WD Series Ductile Iron Butterfly Valves offer reliable performance in a wide range of applications; on/off, throttling, control isolation, flow balancing and diversion. Ideal for use in Industrial and HVAC/Mechanical applications.

Service compatibility is dependant on several factors; the corrosion resistance of the disc and shaft and the chemical resistance of the seat (liner) and required temperature range. Erosion resistance also affects material selection when dealing with abrasive slurries.

EPDM Cartridge Style Seat Ethylene propylene rubber	Buna-N Cartridge Style Seat Nitrile rubber Also known as NBR	Viton® B Cartridge Style Seat Fluorocarbon rubber
Temperature rated from -20°F to 250°F Intermittent, 225°F Continuous	Temperature rated from 10°F to 180°F	Temperature rated from -20°F to 300°F
<p>Typical applications:</p> <ul style="list-style-type: none"> ➤ Food Grade EPDM is Standard ➤ Typically offered for general service and elevated temperatures • Hot water • Chilled water • Glycols • Detergents • Phosphate esters • Ketones • Alcohols • Low Pressure Steam • Dilute acids • Phosphate based hydraulic oils and fluids • Silicone greases and oils • Alkalies 	<p>Typical applications:</p> <ul style="list-style-type: none"> ➤ Food Grade Buna-N is Standard ➤ Good for most general services • Water – ambient temperature • Vacuum • Compressed air • Salt solutions • Alkaline solutions • Dilute acids • Petroleum oils & fluids • Silicone oils & greases • Ethylene glycol 	<p>Typical applications:</p> <ul style="list-style-type: none"> ➤ A fluorocarbon rubber with a wide spectrum of chemical resistance (exceptional resistance to oils and chemicals at higher temperatures). ➤ A fluorocarbon rubber that typically has better chemical resistance than Buna-N. • Hydrocarbons • Mineral acids • Alcohols
<div style="text-align: center;"></div> <ul style="list-style-type: none"> ⊗ EPDM is not recommended for any hydrocarbon-based oils, petroleum oils, hydrocarbon-based lubricants, or di-ester based lubricants, or air systems with hydrocarbons. 	<div style="text-align: center;"></div> <ul style="list-style-type: none"> ⊗ Buna-N can swell in hot water applications, and increase operating torque. ⊗ Buna-N is NOT recommended for strong oxidizing agents, nitrated hydrocarbons, Aromatic hydrocarbons (benzene, toluene, xylene), acetates, phenols, aldehydes, gasolines with additives, Automotive brake fluid, Halogen derivatives (carbon tetrachloride, trichloroethylene), Ketones (MEK, acetone), Phosphate ester hydraulic fluids (Skydrol®, Pydraul®), Strong acids, ozone 	<div style="text-align: center;"></div> <ul style="list-style-type: none"> ⊗ Viton® can swell in higher temperature water applications. ⊗ At low temperatures, Viton®'s flexibility decreases (hardens), which often increases operating torque. ⊗ Viton® is not recommended for ketones, Skydrol fluids, amines, anhydrous ammonia, low molecular weight esters and ethers, hot hydrofluoric chlorosulfonic acids.

BUTTERFLY VALVES

Installation

Apollo® butterfly valves are designed for installation between ANSI Class 125/150 lb. weld-neck or slip-on flanges. While we suggest use of weld neck flanges, Apollo® models are configured to also accept slip-on flanges that eliminate failures associated with conventional butterfly valves. Be sure to properly align flange and valve when using raised face flanges. Type C stub end flanges are not recommended.

Apollo butterfly valves can be used with schedule 40 and schedule 80 steel pipe. When the valve is properly centered between flanges, the disc of an open butterfly valve will not contact the inside diameter of schedule 40 or schedule 80 steel pipe.

Caution: Adjacent piping and components with reduced inside diameters (Lined pipe, Schedule 80 plastic pipe, As-cast rough fittings, etc) could cause disc-pipe contact which could damage the valve's disc and shaft.

INSTALLING WD/LD SERIES VALVES

Begin by positioning the disc at partially open; maintain the disc within the body face-to-face. After positioning the valve body between flanges, install flange bolts.

Do not use flange gaskets. Before tightening flange bolts, adjust disc to the full open position. This helps assure proper alignment and clearance between the outside diameter of the disc and the inside diameter of the pipe. Tighten bolts to spec with disc in full open position. After tightening, rotate disc carefully to closed position to assure proper outside diameter clearance.

MAINTENANCE

Apollo® butterfly valves are designed for extended service with minimal wear and servicing. No regular lubrication is needed. In case of replacement, put disc in a near closed position and remove from line, spread flanges and support the valve while removing flange bolts.

Note: Always depressurize a piping system when removing a manual or power actuator or performing valve maintenance.

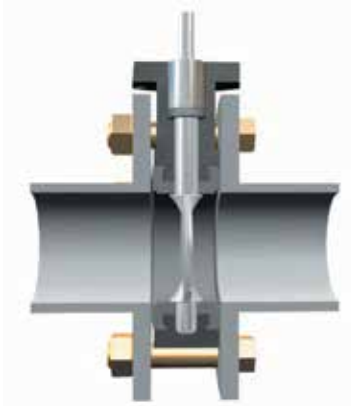

Closed



Partially Open

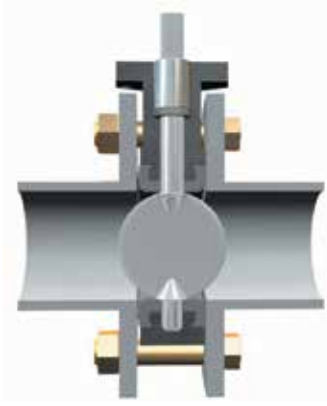

Open

BUTTERFLY VALVES

General Purpose Butterfly Valves – 141 Series & 145 Series

141 Series: Apollo International™

145 Series: Assembled & Tested in USA

WD MODEL

2" - 12"

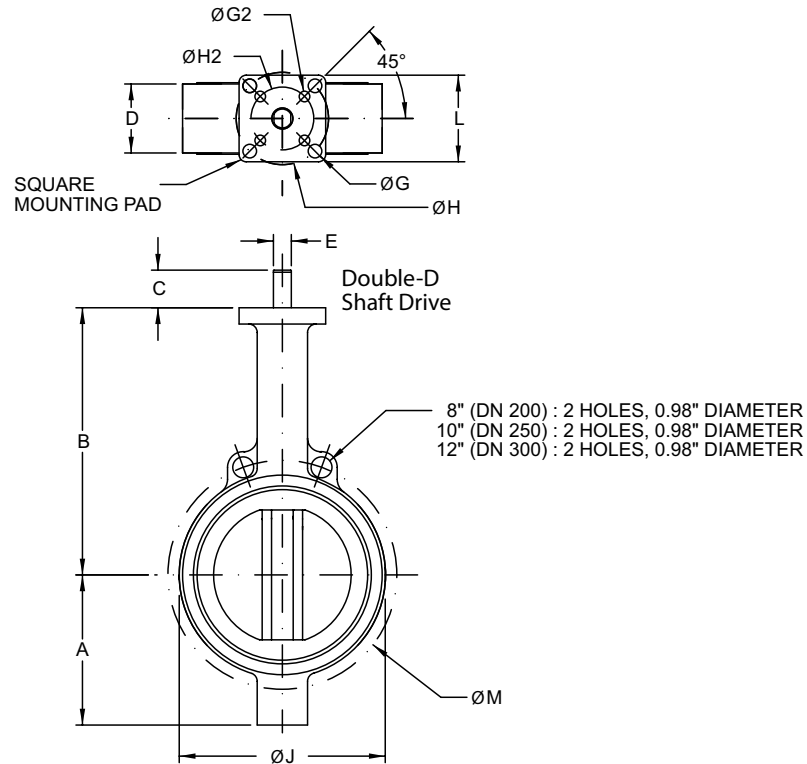

LD MODEL

2" - 12"

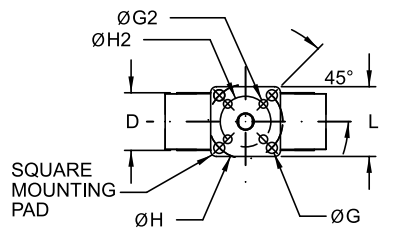

14" - 24"

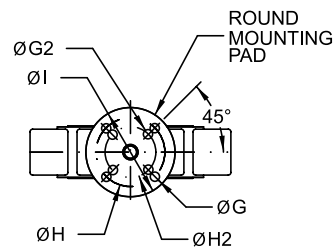

Double-D Shaft Drive

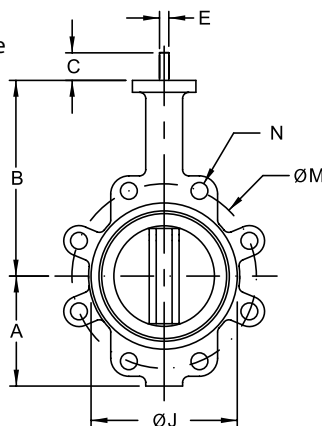

Shaft Drive:
Double-D (14")
Round & Keyed (16" & larger)

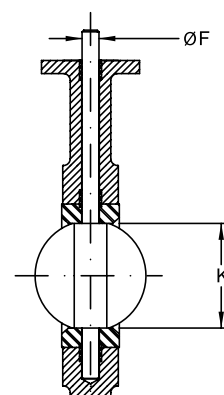

BUTTERFLY VALVES

General Purpose Butterfly Valves – 141 Series & 145 Series

DOUBLE-D AND KEYED STEM

Size Inches	Size DN	Dimensions in Inches																	
		A	B	C	D	E	ØF	ØG	ØG2	Key	ØH	ØH2	ØI	ØJ	K	L	M	N (WD)	N (LD)
2	50	3.25	6.375	1.25	1.75	0.394	0.496	0.375	--	--	2.756	--	2.699	4	2.09	1.113	4.75	0.688	.625-11
2.5	65	3.75	6.880	1.25	1.88	0.394	0.496	0.375	--	--	2.756	--	2.699	4.75	2.54	1.706	5.50	0.688	.625-11
3	80	4.00	7.130	1.25	1.88	0.394	0.496	0.375	--	--	2.756	--	2.699	5.13	3.09	2.450	6.00	0.688	.625-11
4	100	4.88	7.880	1.25	2.13	0.472	0.621	0.375	--	--	2.756	--	2.699	6.75	4.09	3.488	7.50	0.688	.625-11
5	125	5.38	8.380	1.25	2.25	0.551	0.745	0.375	--	--	2.756	--	2.699	7.75	4.85	4.296	8.50	0.813	.625-11
6	150	5.88	8.880	1.25	2.25	0.551	0.745	0.375	--	--	2.756	--	2.699	8.63	6.13	5.697	9.50	0.813	.751-10
8	200	7.13	10.250	1.75	2.50	0.669	0.870	0.563	0.438	--	4.921	4.015	4.606	10.56	7.89	7.468	11.75	0.813	.750-10
10	250	8.25	11.500	1.88	2.75	0.866	1.120	0.563	0.438	--	4.921	4.015	4.606	13.06	9.89	9.484	14.25	0.938	.750-10
12	300	9.75	13.250	1.88	3.13	0.945	1.244	0.563	--	--	4.921	--	4.606	16	11.89	11.456	17.00	0.938	.875-9
14*	350	11.00	14.500	1.88	3.13	0.945	1.244	0.563	--	--	4.921	--	Ø5.91	17.13	13.38	13.000	18.75	1.060	.875-9
16*	400	12.00	15.750	2.00	3.50	--	1.313	0.563	--	0.313	4.921	--	Ø5.91	20	15.38	14.970	21.25	1.060	1.00-8
18*	450	14.38	16.630	2.00	4.25	--	1.500	0.813	--	0.375	6.496	--	Ø8.27	21.38	17.38	16.847	22.75	1.250	1.00-8
20*	500	14.63	18.880	2.50	5.25	--	1.625	0.813	--	0.375	6.496	--	Ø8.27	23.31	19.38	18.650	25.00	1.250	1.125-7
24*	600	18.00	22.130	2.75	6.13	--	2.000	0.813	--	0.500	6.496	--	Ø8.27	27.88	23.38	22.558	29.50	1.380	1.125-7

*LD141 Series only

Approximate Weight for Bare Shaft Valve

Valve Size		WD Model Lbs (kg)	LD Model Lbs (kg)
Inches	DN		
2	50	6 (2.7)	8 (3.6)
2.5	65	6 (2.7)	10 (4.5)
3	80	7(3.2)	11 (5.0)
4	100	11 (5.0)	17 (7.7)
5	125	13 (5.9)	20 (9.1)
6	150	16 (7.3)	23 (10.4)
8	200	29 (13.2)	39 (17.7)
10	250	44 (20.0)	62 (28.1)
12	300	70 (31.8)	97 (44.0)
14*	350		148 (67.1)
16*	400		206 (93.4)
18*	450		277 (125.6)
20*	500		410 (186.0)
24*	600		592 (268.5)

*LD141 Series only

141 Series: Apollo International™
145 Series: Assembled & Tested in USA

BUTTERFLY VALVES

Handle and Gear Dimensions – 141 Series & 145 Series

141 Series: Apollo International™

145 Series: Assembled & Tested in USA

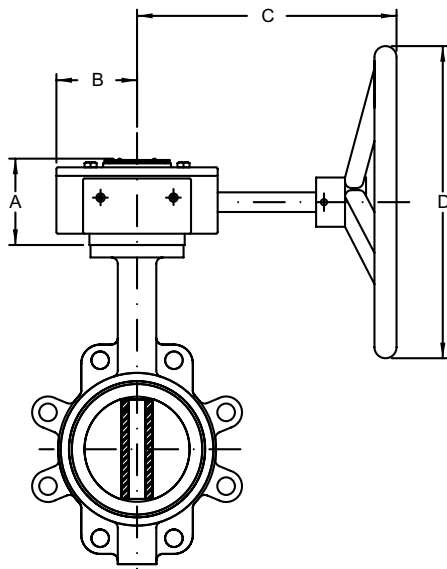

with Manual Gear

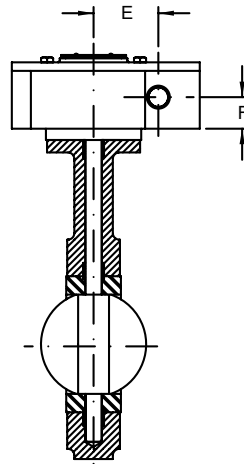

with Manual Gear

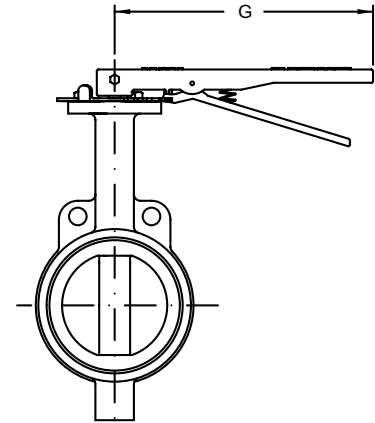

with Handle

NOTE: All Gear Operators supplied with 12" Handwheels with gearing to provide RIM pull at 50# or less.

Valve Size		Gear Ratio	Dimensions in Inches						
Inches	DN		A	B	C	D	E	F	G
2"	50	30:1	3.4	3.0	9.2	11.9	2.5	1.5	10.5
2.5"	65	30:1	3.4	3.0	9.2	11.9	2.5	1.5	10.5
3"	80	30:1	3.4	3.0	9.2	11.9	2.5	1.5	10.5
4"	100	30:1	3.4	3.0	9.2	11.9	2.5	1.5	10.5
5"	125	30:1	3.4	3.0	9.2	11.9	2.5	1.5	10.5
6"	150	30:1	3.4	3.1	8.9	11.9	2.5	1.5	10.5
8"	200	50:1	3.4	3.3	8.9	11.9	3.0	1.6	14.0
10"	250	50:1	3.4	3.3	8.9	11.9	3.0	1.6	14.3
12"	300	50:1	3.4	3.3	8.9	11.9	3.0	1.6	14.3
14"*	350*	50:1	3.4	3.3	8.9	11.9	3.0	1.6	--
16"*	400*	80:1	4.8	5.1	11.8	11.9	4.7	2.3	--
18"*	450*	80:1	4.8	5.1	11.8	11.9	4.7	2.3	--
20"*	500*	300:1	5.9	5.1	13.8	11.9	4.7	2.8	--
24"*	600*	300:1	5.9	5.1	13.8	11.9	4.7	2.8	--
30"*	750*	640:1	4.9	5.1	11.9	15.7	7.8	5.0	--
36"*	900*	640:1	4.9	5.1	11.9	15.7	9.0	5.0	--

*LD141 Series only

BUTTERFLY VALVES

Operating Torque – 141 Series, 145 Series & 149 Series

All torque valves shown in the chart are for wet (water and other non-lubricating media) on-off service. For dry services (non-lubricating, dry gas media) multiply the values by 1.15. For lubricous services (clean, non-abrasive lubricating media) multiply values by 0.85.

Under certain conditions, hydrodynamic torque can meet or exceed seating and unseating torques. When designing valve systems, hydrodynamic torque must be considered to help ensure correct selection of actuation.

Velocity Limits

VELOCITY LIMITS

- For ON/OFF Services
- Non-abrasive liquids - 30 feet/sec (9m/sec)
- Gases - 175 feet/sec (54m/sec)

Torque Rating (lbs-in)

Valve Size		Full Rated Pressures (psig)			
Inches	DN	ΔP 50	ΔP 100	ΔP 150	ΔP 200
2	50	100	106	111	117
2.5	65	150	163	176	189
3	80	207	220	232	244
4	100	290	323	357	390
5	125	423	481	540	598
6	150	599	691	783	875
8	200	1060	1183	1307	1430
10	250	1671	1872	2074	2275
12	300	2568	2795	3023	3250
14*	350*	2640	3070	3500	N/A
16*	400*	4260	4880	5500	N/A
18*	450*	6287	7243	8200	N/A
20*	500*	8360	9180	10000	N/A
24*	600*	15427	16813	18200	N/A

*LD141 only

Cv Data – 141 Series, 145 Series & 149 Series

Cv values (US gallons per minute) represent the flow of 60°F water through a 100% open valve at a pressure drop of 1 psi.

The metric equivalent, Kv, is the flow of water at 16°C through the valve in cubic meters per hour at a pressure drop of 1 kg/cm². To convert Cv to Kv, multiply the Cv by 0.8569.

Rated Flow Coefficient (Cv)

Valve Size		Angle of Disc Opening (degrees)								
Inches	DN	10°	20°	30°	40°	50°	60°	70°	80°	90°
2	50	0.06	3	7	15	27	44	70	105	115
2.5	65	0.10	6	12	25	45	75	119	178	196
3	80	0.20	9	18	39	70	116	183	275	302
4	100	0.30	17	36	78	139	230	364	546	600
5	125	0.50	29	61	133	237	392	620	930	1022
6	150	0.80	45	95	205	366	605	958	1437	1579
8	200	2	89	188	408	727	1202	1903	2854	3136
10	250	3	151	320	694	1237	2047	3240	4859	5340
12	300	4	234	495	1072	1911	3162	5005	7507	8250
14*	350*	6	338	715	1549	2761	4568	7230	10844	11917
16*	400*	8	464	983	2130	3797	6282	9942	14913	16388
18*	450*	11	615	1302	2822	5028	8320	13168	19752	21705
20*	500*	14	791	1674	3628	6465	10698	16931	25396	27908
24*	600*	22	1222	2587	5605	9989	16528	26157	39236	43116

*LD141 only

This chart should be used as a general guide.

For additional Cv information, consult the **Engineering and Application Data Section**. Cv = the volume of water in U.S. gallons per minute that will pass through a given valve opening with a pressure drop of 1 psig at room temperature.

BUTTERFLY VALVES

Contractor Grade Butterfly Valves – 149 Series



The Apollo® LC149 Series Cast Iron Butterfly Valves are ideal for use in Industrial and HVAC/Mechanical applications. The LC149 Series is a lug style valve designed to be economical yet full featured.

STANDARD MATERIALS

Body	Cast Iron, ASTM A126 Class B
Disc	Aluminum Bronze, ASTM B148-C95400
Shaft	Stainless Steel, ASTM A276, Type 416
Seat	Black EPDM (FDA food grade) with phenolic backing
Bushings	PTFE
Stem Seal	EPDM

PERFORMANCE RATING

- Max Operating Pressure: 200 psi (13.8 bar)
- Temperature Range: -20°F to 250°F Intermittent, 225°F Continuous (-29° C to 107° C)

APPROVALS

- NSF/ANSI 372 Lead Free
- Registered under Canadian Registration Number CRN# 0C12102.8CL

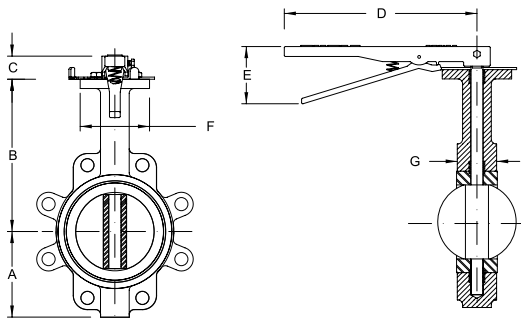

Size (in)	Dimensions in Inches – 149 Series with Handle						
	A	B	C	D	E	F	G
2	3.25	6.38	1.25	10.5	3.1	2.70	1.75
2.5	3.75	6.88	1.25	10.5	3.1	2.70	1.88
3	4.00	7.13	1.25	10.5	3.1	2.70	1.88
4	4.88	7.88	1.25	10.5	3.1	2.70	2.13
5	5.38	8.38	1.25	10.5	3.1	2.70	2.25
6	5.88	8.88	1.25	10.5	3.1	2.70	2.25
8	7.13	10.25	1.75	14.3	3.5	4.61	2.50
10	8.25	11.50	1.88	14.3	3.5	4.61	2.75
12	9.75	13.25	1.88	14.3	3.5	4.61	3.13

Size (in)	Dimensions in Inches – 149 Series with Gear Operator									
	A	B	C	D	G	H	J	K	P	ØR
8	7.13	10.25	3.38	8.00	2.50	1.62	9.48	3.25	1.50	11.88
10	8.25	11.50	3.38	8.00	2.75	1.62	9.48	3.25	1.50	11.88
12	9.75	13.25	3.38	8.00	3.13	1.62	9.48	3.25	1.50	11.88

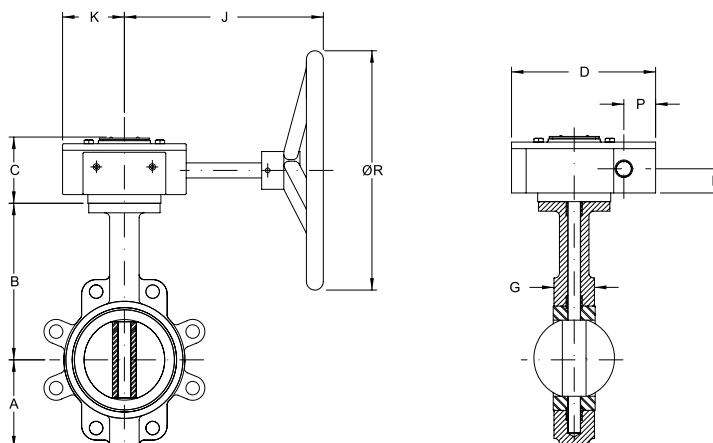

BUTTERFLY VALVES

How to Order WD and LD Butterfly Valves

CERTIFIED LEAD FREE NSF/ANSI 372 – MODEL NUMBER

WD	141	06	B	E	1	1	-S
MODEL	SERIES	SIZE (IN.)	DISC MATERIAL	SEAT MATERIAL	SHAFT	OPERATOR	
LD = Lug Body (Ductile Iron) WD = Wafer Body (Ductile Iron) (2" - 12" Only)	141 = Apollo International™ 145 = Assembled & Tested in USA	02 = 2" 25 = 2.5" 03 = 3" 04 = 4" 05 = 5" 06 = 6" 08 = 8" 10 = 10" 12 = 12" 14 = 14" 16 = 16" 18 = 18" 20 = 20" 24 = 24" 30 = 30"	B = Aluminum Bronze D = Ductile Iron A536 Nickel Plated S = Stainless Steel, CF8M	E = Black EPDM** -30° F to 275° F -34° C to 135° C N = Black BUNA-N** 10° F to 180° F -12° C to 82° C V = Black Viton® B † -15° F to 400° F -26° C to 204° C (145 Series Only) ** FDA Food Grade	1 = Std. 416 SS	0 = Bare Shaft 1 = 10 Position Handle 2 = Gear Operator - Direct Mount 3 = Infinite Position Handle 4 = Locking Handle 5 = Gear Operator w/ Chainwheel 7 = Locking Gear Operator 8 = Locking Gear Operator w/Chainwheel -S = Silicone Free Assembly (145 Series Only)	

NOTES:  • **Certification** - Product complies with NSF/ANSI 372 lead content requirements for "lead free" plumbing as defined by the U.S. Safe Drinking Water Act that took effect January 4, 2014. †

† Viton is primarily used for process applications, and has not been included in the scope of our Lead Free approvals

EXAMPLE:

WD141-06-BE-11: 6" WD141 Series, Ductile Iron Wafer Body, Aluminum Bronze Disc, Black EPDM Seat, 416 SS Shaft with 10 Position Handle

How to Order LC149 Butterfly Valves - Contractor Grade

CERTIFIED LEAD FREE NSF/ANSI 372 – MODEL NUMBER

LC149	06	1
SERIES	SIZE (IN.)	OPERATOR
LC149 = Cast Iron Lug Body Aluminum Bronze Disc 416 SS Shaft Black EPDM Seat	02 = 2" 25 = 2.5" 03 = 3" 04 = 4" 05 = 5" 06 = 6" 08 = 8" 10 = 10" 12 = 12"	1 = 10 Position Handle (2" - 12") 2 = Gear Operator (8" - 12" only)

NOTES:  • **Certification** - Product complies with NSF/ANSI 372 lead content requirements for "lead free" plumbing as defined by the U.S. Safe Drinking Water Act that took effect January 4, 2014.

EXAMPLE:

LC149-06-1: 6" LC149 Series, Cast Iron Body, Aluminum Bronze Disc, Black EPDM Seat, 416 SS Shaft with 10 Position Handle

Pricing

NOTE: Pricing of valves and options may be accessed through published Price List BFPL9000 or by Authorized Apollo Online users.

BUTTERFLY VALVES

Apollo International™ Double Offset High Performance Butterfly Valve



**COMING
SOON!**

AVAILABLE SUMMER 2014

Soft Seat, Fire-Safe Seat, Metal Seat

2" - 24" Class 150 (215 L/W)

2" - 24" Class 300 (230 L/W)

3" - 12" Class 600 (260 L/W)

MATERIALS

Carbon and Stainless Steel Models Available

Consult www.mmcontrol.com for availability.

Warranty and Limitations of Liability

Conbraco Industries, Inc. warrants, to its initial purchaser only, that its products which are delivered to the initial purchaser will be of the kind described in the order or pricelist and will be free of defects in workmanship or material for a period of TWO years from the date of delivery to you, our initial purchaser.

Should any failure to conform to this warranty appear within two years after the date of the initial delivery to our initial purchaser, Conbraco will, upon written notification thereof and substantiation that the goods have been stored, installed, maintained and operated in accordance with Conbraco's recommendations and standard industry practice, correct such defects by suitable repair or replacement at Conbraco's own expense.

THIS WARRANTY IS EXCLUSIVE AND IS IN LIEU OF ANY IMPLIED WARRANTY OF MERCHANTABILITY, FITNESS FOR A PARTICULAR PURPOSE OR OTHER WARRANTY OF QUALITY WHETHER EXPRESSED OR IMPLIED, EXCEPT THE WARRANTY OF TITLE AND AGAINST PATENT INFRINGEMENT. Correction of non-conformities, in the manner and for the period of time provided above, shall constitute fulfillment of all liabilities of Conbraco to our initial purchaser, with respect to the goods, whether based on contract, negligence, strict tort or otherwise. It is the intention of Conbraco Industries, Inc. that no warranty of any kind, whether express or implied, shall pass through our initial purchaser to any other person or corporation.

LIMITATION OF LIABILITY: Conbraco Industries, Inc. SHALL NOT UNDER ANY CIRCUMSTANCES BE LIABLE FOR SPECIAL OR CONSEQUENTIAL DAMAGES SUCH AS, BUT NOT LIMITED TO, DAMAGES OR LOSS OF OTHER PROPERTY OR EQUIPMENT, LOSS OF PROFITS OR REVENUE, COST OF CAPITAL, COST OF PURCHASED OR INITIAL PURCHASER, AND ALL OTHERS, SET FORTH HEREIN ARE EXCLUSIVE, AND THE LIABILITY OF CONBRACO WITH RESPECT TO SAME SHALL NOT, AS EXPRESSLY PROVIDED HEREIN, EXCEED THE PRICE OF THE GOODS UPON WHICH SUCH LIABILITY IS BASED.