

Two Valve PowerStation™ Supply Fixture Capacity up to 271 gpm @ 45psi

Technical Instructions

Description ■

Powerstation™ is a complete, fully assembled water tempering system, designed to provide safe water throughout commercial and institutional facilities. Powerstation™ features the HydroGuard® LM490 or LFLM490, HydroGuard® XP MM430 or LFMM430, and SH1430 or LFSH1430 Master Tempering Series valve which utilize paraffin-based actuation technology to sense and to adjust outlet temperature. Each Powerstation™ is mounted on heavy-duty, welded struts and factory tested as a complete system. Each Powerstation™ includes an engineer specified circulator, GFCI outlet, combination temperature/pressure gauges and Powers' triple-duty checkstops. Optional equipment includes an Aquastat and/or Powers' exclusive automatic balancing valve and a internal bypass loop for and easy set-up.

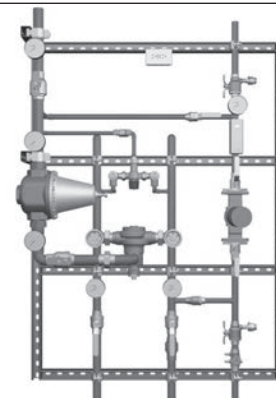

Advanced Thermal Activation

Specifications ■

- Maximum Operating Pressure 125psi (861 kPa)
- Maximum Hot Water Temperature 200°F (93°C)
- Minimum Hot Water Supply Temp.* 5°F (3°C) Above Set Point
- Hot Water Inlet Temperature Range 120 - 180°F (49 - 82°C)
- Cold Water Inlet Temperature Range 40 - 80°F (4 - 27°C)
- Minimum Flow** 0.5 gpm (1.89 lpm)
- Temp. Adjustment Range *** 90 - 160°F (32 - 71°C)
- Listing/Compliance (Valve Only)..... ASSE 1017, CSA B125

* With Equal Pressure

** Minimum flow when 2VPS is installed at or near hot water source recirculating tempered water with a properly sized continuously operating recirculating pump.

*** Note: Low limit cannot be less than the cold water temperature. For best operation, hot water should be at least 5°F (3°C) above desired set point.

Capacity ■

WARNING: TO ENSURE THE ACCURATE AND RELIABLE OPERATION OF THIS PRODUCT, IT IS ESSENTIAL TO:

- Properly size each valve based on the individual application.
- Properly design the recirculation system to minimize pressure and temperature variations.
- Conduct an annual maintenance program to ensure proper operation of all critical components.

THIS VALVE MUST BE USED IN CONJUNCTION WITH TEMPERATURE ACTUATED POINT-OF-USE DEVICES THAT COMPLY WITH ASSE 1016, 1069, OR 1070. FAILURE TO COMPLY WITH PROPER INSTALLATION INSTRUCTIONS COULD CONTRIBUTE TO VALVE FAILURE, RESULTING IN INJURY OR DEATH.

Flow Capacity at 50-50 Mixed Ratio								
		Pressure Drop Across Valve						
Model	Min. Flow to ASSE 1017	Cv	5psi (34 kPa)	10psi (69 kPa)	20psi (138 kPa)	30psi (207 kPa)	45psi (310 kPa)	60psi (414 kPa)
MM431HL and LFMM431HL	0.5 gpm 1.89 lpm	9.70	22 gpm 83 lpm	31 gpm 117 lpm	43 gpm 163 lpm	53 gpm 201 lpm	65 gpm 246 lpm	75 gpm 284 lpm
MM432HL and LFMM432HL	0.5 gpm 1.89 lpm	13.00	29 gpm 110 lpm	41 gpm 155 lpm	58 gpm 220 lpm	66 gpm 250 lpm	87 gpm 329 lpm	93 gpm 352 lpm
MM433HL and LFMM433HL	0.5 gpm 1.89 lpm	19.80	44 gpm 167 lpm	63 gpm 238 lpm	86 gpm 326 lpm	108 gpm 409 lpm	133 gpm 503 lpm	153 gpm 579 lpm
MM434HL and LFMM434HL	0.5 gpm 1.89 lpm	24.90	56 gpm 212 lpm	79 gpm 299 lpm	111 gpm 420 lpm	136 gpm 515 lpm	167 gpm 632 lpm	193 gpm 731 lpm
MM435HL and LFMM435HL	3.0 gpm 11.0 lpm	27.70	62 gpm 235 lpm	88 gpm 333 lpm	124 gpm 469 lpm	152 gpm 575 lpm	186 gpm 704 lpm	215 gpm 814 lpm
SH1432DV and LFSH1432DV	2 gpm 8 lpm	27.40	61 gpm 231 lpm	87 gpm 329 lpm	123 gpm 466 lpm	150 gpm 568 lpm	184 gpm 697 lpm	213 gpm 806 lpm
SH1434DV and LFSH1434DV	2 gpm 8 lpm	37.40	84 gpm 318 lpm	118 gpm 447 lpm	167 gpm 632 lpm	205 gpm 776 lpm	251 gpm 950 lpm	290 gpm 1098 lpm
SH1432HL and LFSH1432HL	1 gpm 4 lpm	30.00	67 gpm 254 lpm	95 gpm 360 lpm	134 gpm 507 lpm	164 gpm 621 lpm	201 gpm 761 lpm	232 gpm 878 lpm
SH1434HL and LFSH1434HL	1 gpm 4 lpm	40.40	90 gpm 341 lpm	128 gpm 485 lpm	181 gpm 685 lpm	221 gpm 837 lpm	271 gpm 1026 lpm	313 gpm 1185 lpm

Prior to Installation ■

1. Flush all piping thoroughly before installing.
2. Check for leaks.

Set Up Procedure ■

NOTE: Perform all 22 steps before moving on to the next section.

Steps 1 thru 22 explain how to set the thermostatic valve.

1. Close B3, B4 and B6.
2. Close D1 and D2.
3. Open B1, B2, B5, B7 and B8.
4. Connect hose to D2 and run to a drain.
5. Open D2 with a screwdriver and verify flow to drain is greater than the minimum flow of the valve.
6. For system with an automatic balancing valve, adjust the knob to full hot position (force the water through the hose).
7. If flow rate is less than the minimum flow, turn pump P1 on.
8. Let valve run until readings on inlet gauges T/P2 & T/P3 are steady.
9. Close the low flow valve B8.
10. Adjust temperature of high flow mixing valve. Refer to IS-P-MM430 and IS-P-SH1430.
11. For "HL" valves, set the PRV as follows; for a 15psi differential for "DV" valves, skip to # 12.
 - a) Loosen the locknut at the top of the PRV. This must be all the way or you will be limiting the range of adjustment.
 - b) Adjust the PRV so the outlet pressure gauge (top) reads 15psi less than the supply pressure gauge (bottom). Turning the adjustment nut counterclockwise will increase the differential across the PRV (allowing the PRV to open later)
12. Close the ball valve at the discharge of the high flow valve, B7 and open the low flow side ball valve B8.
13. Set the temperature of the low flow valve. Refer IS-P-LM490-LM490-10 or IS-P-SH1430.
14. Open the ball valve at the discharge of high flow valve B7.
15. Increase total flow.
16. Verify temperature remains at set point.
17. Gradually start to close D2 to verify that the temperature remains constant through the full range of flow.
18. Turn off pump.
19. Close B5 and open B4.
20. Open D1 to purge air out of recirculation line.
21. Close D1 when you begin to get water.
22. Open B6 and wait until T/P4 reaches the maximum recirculation temperature (must be less than the mixing valve setpoint).
23. Skip to the type of recirculation below.

Aquastat ■

1. Close D2 and open B3.
2. Apply power to pump P1.
3. Set the Aquastat on and off temperatures.
4. With the recirculation temperature set to its maximum, the pump/Aquastat will remain off until the temperature cools to the low point.
5. Wait until the recirculation line cools to the low point.
6. Verify the pump turns on at this point.
7. Verify recirculation line heats back up and turns pump off at the maximum setting from Step 3.
8. The system is now set.

Continuous Recirculation ■

1. Close D2
2. Open B3 fully and open C1 approximately 10%.
3. Allow time for recirculated water to travel around the loop.
4. If the temperature at the T/P4 begins falling, you will need to open C1 another 10%.
5. If the temperature at T/P4 begins to rise, you will need to close C1 by 5%.
6. Repeat steps 4 and 5 until the temperature at T/P4 is stable (less than the set point of the mixing valve).
7. The system is now set.

Continuous Recirculation with Automatic Balancing Valve ■

1. For systems with an automatic balancing valve, adjust the knob to the full cold position (restrict the flow of water through the hose to a trickle).
2. Slowly turn the automatic balancing valve's knob toward the hot position until you just start to get water through the hose. At this point, it is set to the temperature shown on T/P4.
3. Close D2.
4. Open B3.
5. The system is now set.

NOTE: For any problem, refer to Troubleshooting section of the document or contact Powers' Technical Support Department at 1.800.669.5430 or info@powerscontrols.com.

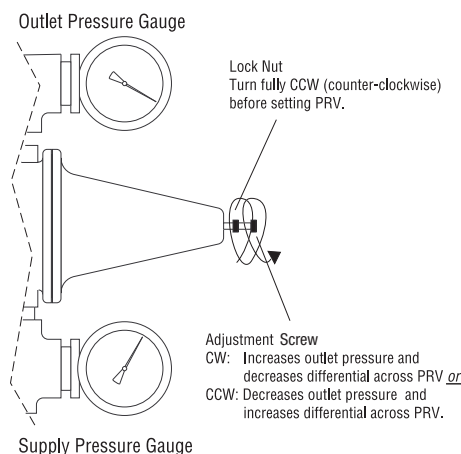

Legends ■

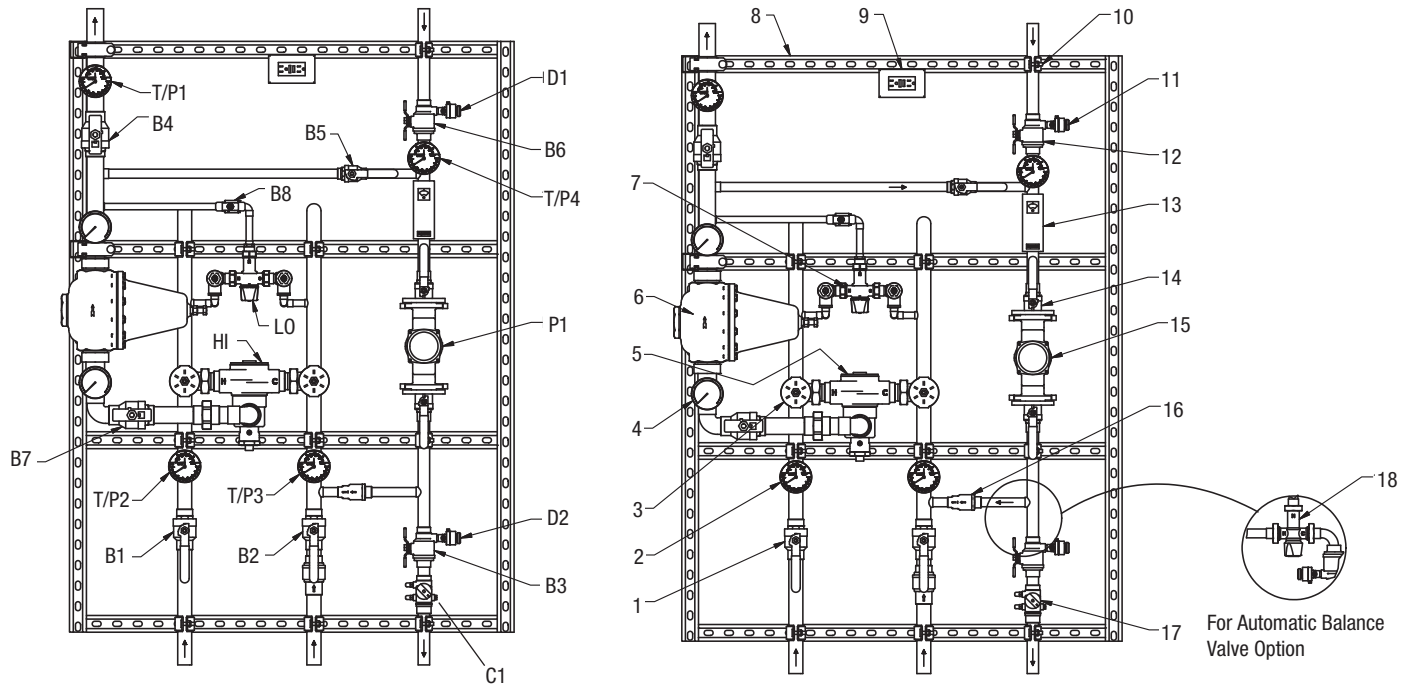

Item Number	Item Description	Options	Quantity Required
1	Ball Valve	Std	5
2	Temperature / Pressure Gauge	Std	4
3	Triple Duty Checkstop	Std	4
4	Pressure Gauges	Std	2
5	Thermostatic Valve (HI)	See Order Code	1
6	Pressure Reducing Valve	Std	1
7	Thermostatic Valve (LO)	See Order Code	1
8	Welded Mounting Struts	Std	Typical
9	GFCI Outlet	Std	1
10	Pipe Straps	Std	Typical
11	Vacuum Breaker	Std	2
12	Ball Valve w/Drain	Std	2
13	Aquastat	Optional	1
14	Isolation Flange	Std	2
15	Circulator	Application Specific	1
16	Check Valve	Std	2
17	Circuit Setter	Optional	1
18	Automatic Balance Valve	Optional	1

Troubleshooting ■

What to look for if:

- **Outlet temperature is too hot with low flow:**
 1. The thermal actuator of the valve is not working properly. Test and replace according to the appropriate technical instructions, IS-P-MM430, IS-P-LM490-LM490-10 or IS-P-SH1430 enclosed.
- **Outlet temperature is too hot with a high flow:**
 1. The thermal actuator of the valve is not working properly. Test and replace accordingly, IS-P-MM430 or IS-P-SH1430.
- **Outlet temperature too low on low and high flow:**
 1. The hot water temperature is too low. You must have a supply temperature of at least 5° F (3° C) higher than the set temperature. Readjust the hot water supply.
 2. The checkstops on the hot side of the valve are not fully open or may be stuck due to liming. Open and clean checkstops.
 3. The temperature has not been set properly on the small and/or large valve. Refer to set up procedure and reset the valves.
- **Outlet flow drops off:**
 1. The checkstops are not fully open or stuck. Open and clean checkstops.
 2. The system pressure varies by more than 50% of the inlet supply pressure.
- **Outlet temperature cycles between hot and cold:**
 1. The system pressure varies by more than 50% of the inlet supply pressure.

Preventative Maintenance ■

Thermostatic water mixing valves are control devices which must be cleaned and maintained on a regular basis.

1. Before servicing checkstops or piping, turn off the water upstream. At least every twelve (12) months, open up the checkstops and check for the free movement of the poppet.
2. Before servicing the valve, turn off the water supply upstream or close the checkstops. To close the checkstops, turn the adjusting screw clockwise.
3. When opening checkstops after servicing, turn adjusting screw counterclockwise to fully open position then turn adjusting screw 1/2 turn clockwise for final setting.
4. Every three (3) months, check the maximum temperature adjustments.
5. Every twelve (12) months, remove the valve bonnets and check the internal components for freedom of movement.

CAUTION:

Any changes in supply condition could effect the outlet water temperature. Check and adjust the valves accordingly to prevent injury to the users.

Part List For Valve ■

See enclosed IS-P-MM430 and IS-P-SH1430.

CALIFORNIA PROPOSITION 65 WARNING

WARNING: This product contains chemicals known to the State of California to cause cancer and birth defects or other reproductive harm. (California law requires this warning to be given to customers in the State of California.)

For more information: www.watts.com/prop65



NOTE: AFTER COMPLETING REPAIRS, CHECK DISCHARGE TEMPERATURE. RESET IF NECESSARY.

WARNING: FAILURE TO PERFORM THIS OPERATION COULD RESULT IN UNSAFE DISCHARGE TEMPERATURE, WHICH MAY CAUSE INJURY OR DEATH.

Warranty ■

The Seller warrants that the equipment manufactured by it and covered by this order or contract is free from defects in material and workmanship and, without charge, equipment found to be defective in material or workmanship will be repaired, or at Seller's option replaced F.O.B. original point of shipment, if written notice of failure is received by Seller within one (1) year after date of shipment (unless specifically noted elsewhere), provided said equipment has been properly installed, operated in accordance with the Seller's instructions, and provided such defects are not due to abuse or decomposition by chemical or galvanic action. THIS EXPRESS WARRANTY IS IN LIEU OF AND EXCLUDES ALL OTHER WARRANTIES, GUARANTEES, OR REPRESENTATIONS, EXPRESS OR IMPLIED. THERE ARE NO IMPLIED WARRANTIES OF MERCHANTABILITY OR OF FITNESS FOR A PARTICULAR PURPOSE. The Seller assumes no responsibility for repairs made on the Seller's equipment unless done by the Seller's authorized personnel, or by written authority from the Seller. The Seller makes no guarantee with respect to material not manufactured by it.

POWERS™

A Watts Water Technologies Company

**ISO 9001-2000
CERTIFIED**