

EP-1601
OCTOBER 31, 2005

FIREYE[®] EP160, EP161, EP163, EP165, EP166, EP170, EP174 and EP177 PROGRAMMER MODULES

WITH SELECTABLE OPERATION



DESCRIPTION

The Fireeye EP160, EP161 (extended MTFI), EP163 (programmable), EP170 and EP174 (early spark termination), EP165, EP166 (pilot stabilization) or EP177 (early spark termination and programmable operating parameters) programmer modules are used with the FLAME-MONITOR Burner Management Control System (P/N's E100 and E110). Several operational characteristics of the programmer are determined by six (6) dipswitches located on the side of the programmer. These characteristics include forced blower motor start delay (dipswitch 1), extended purge timing (dipswitches 3, 4, 5) and the option requiring the 3-P running interlock circuit to be proven open at the start of the operating cycle (dipswitch 6). Dipswitch 2 is inactive. Models EP163 and EP177 characteristics are programmed via the ED510 Display Module, rather than by dipswitch.

The EP160, EP161, EP163, EP165, EP166, EP170, EP174 and EP177 programmers provide start-up programming, safe-start check, and flame monitoring supervision. They insure open damper (high purge) prepurge, proof of low fire position, and fuel valve end switch safety checks. A running interlock circuit on the FLAME-MONITOR system constantly monitors the limit switches, air flow switches, and fuel pressure switches through the programmer. The programmer control is designed to initiate a safety lockout if any of these circuits are open at the improper point in the control cycle.

The programmer module will de-energize all fuel valve circuits within four (4) seconds (max.) following a flame failure [two (2) seconds for the EP165 and EP166], or at the end of the pilot trial for ignition period if no flame is detected. An alarm circuit will be energized following a safety lockout.

The programmer module includes an RJ45 style connector to interface with an integral or remote alpha-numeric display (P/N ED510). It is also backward compatible with the ED500 display. It includes two (2) additional RJ style connectors to connect to an E500 communication interface in a multi-drop configuration or allow communication via a Modbus protocol. The programmer will also communicate with the E500 via the ED550 cables to provide backward compatibility.

The programmer is the heart of the FLAME-MONITOR System and features a plug-in design for ease of installation. It is micro-processor based and stores the burner cycles, burner hours, system hours, and lockout history (with burner cycle and burner hour time stamp) which are accessible via the ED510 alpha-numeric display, E500 Communication Interface, InTouch Wireless Monitoring System or Modbus communications. If replaced, the new programmer card will begin accumulating a new history.

Refer to Bulletin E-1101 for detailed information on the FLAME-MONITOR System.



INSTALLATION



CAUTION: To prevent shock hazard, remove power from the system wiring base before proceeding. Remove control from the wiring base before proceeding.

The EP programmer modules are used with the Fireeye EB700 and E110 chassis. They are installed in the chassis by inserting the EP programmer module into the second slot on the control. This slot is marked "Programmer Module" on the side of the chassis. Refer to bulletin E-1101 for complete system information.

The programmer module is designed to fit only in the proper slot. It cannot be snapped into place if inserted in the wrong location. **DO NOT FORCE THEM.**

An amplifier module, display module ED510 (ED500 is obsolete), flame scanner, and wiring base are also required for the FLAME-MONITOR control.

All programmers with an Engineering code of 28 or later (e.g. 9414-28) are compatible with both the ED500 and ED510 display modules. See "Programmer and Display Module Compatibility" later in this document. The Engineering code is located on the back side of the board in the lower right hand corner. The EP163 programmer requires the ED510 display for initial configuration programming.

APPROVALS

UNDERWRITERS LABORATORIES INC.

Listed: Guide MCCZ

File MP1537

CANADIAN STANDARDS ASSOCIATION

File #LR7989

ACCEPTABLE BY: INDUSTRIAL RISK INSURERS (I.R.I.)

FACTORY MUTUAL (FM) APPROVED



WARNING: This equipment generates, uses and can radiate radio frequency energy, and if not installed and used in accordance with the instruction manual, may cause interference to radio communications. It has been tested and found to comply with the limits for a Class A computing device pursuant to Subpart J of Part 15 of FCC Rules, which are designed to provide reasonable protection against such interference when operated in a commercial environment. Operation of this equipment in a residential area is likely to cause interference, in which case the user, at his own expense, will be required to take whatever measures may be required to correct the interference.



ORDERING INFORMATION

PART NUMBER	PURGE ¹	IGNITION TIMING			FFRT ²
			PTFI	MTFI	
EP160	30 Sec. ¹	Term 5	10 Sec.	10 Sec.	4 Sec.
		Term 6	10 Sec.	15 Sec.	
EP161	30 Sec. ¹	Term 5	10 Sec.	10 Sec.	4 Sec.
		Term 6	10 Sec.	30 Sec.	
EP163	40 Sec. ⁵	Term 5	5 Sec. ⁵	5 Sec. ⁵	4 Sec.
		Term 6	5 Sec. ⁵	5 Sec. ⁵	
EP165 ⁴	30 Sec. ¹	Term 5	10 Sec.	—	2 Sec.
		Term 6	10 Sec.	10 Sec. ³	
EP166 ⁴	30 Sec. ¹	Term 5	10 Sec.	—	2 Sec.
		Term 6	10 Sec.	15 Sec. ³	
EP170 EP174 ⁶	30 Sec. ¹	Term 5	5 Sec.	—	4 Sec.
		Term 6	10 Sec.	10 Sec.	

¹ Purge timings are adjustable. See "Dipswitches — Purge Timing."
² FFRT is the Flame Failure Response Time.
³ During MTFI, terminal 6 is energized for 5 seconds (pilot stabilization) before energizing terminal 7 for 10 seconds (EP165) or 15 seconds (EP166).
⁴ EP 165 and EP166 will lockout in the event of a power interruption.
⁵ EP163 purge and ignition timings are programmable via ED510.
⁶ M-D Low Fire start is proven closed during PTFI and MTFI.

Note: EP160, EP161, EP163, EP165, EP166, EP170, EP174 and EP177 have non-recycle running interlock circuits (3/P).

WARNING: While all controls are mechanically interchangeable because they mate with a common wiring base, you must select the correct model for your application. Inappropriate application of a control could result in an unsafe condition hazardous to life and property.

TIMING CHARTS

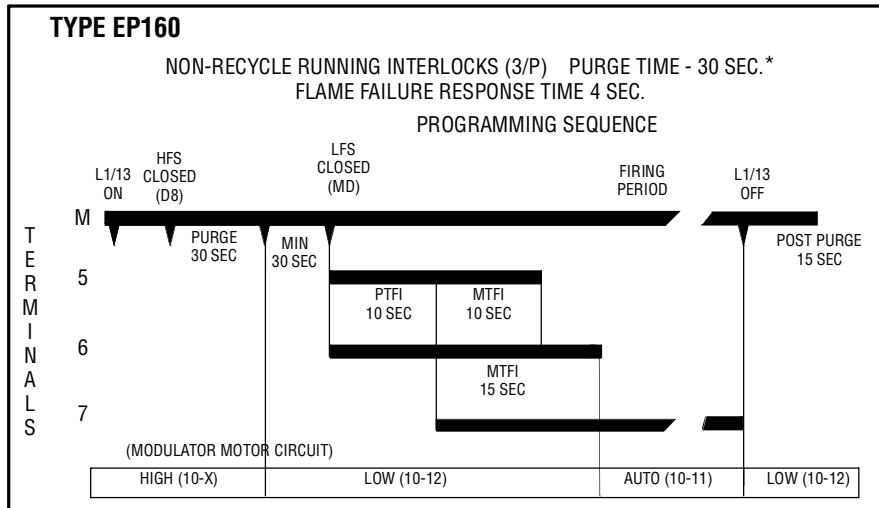

DIPSWITCH SETTINGS

1	2	3	4	5	6
INACTIVE	Down	Down	Down	Down	Down

* Purge timings are adjustable.

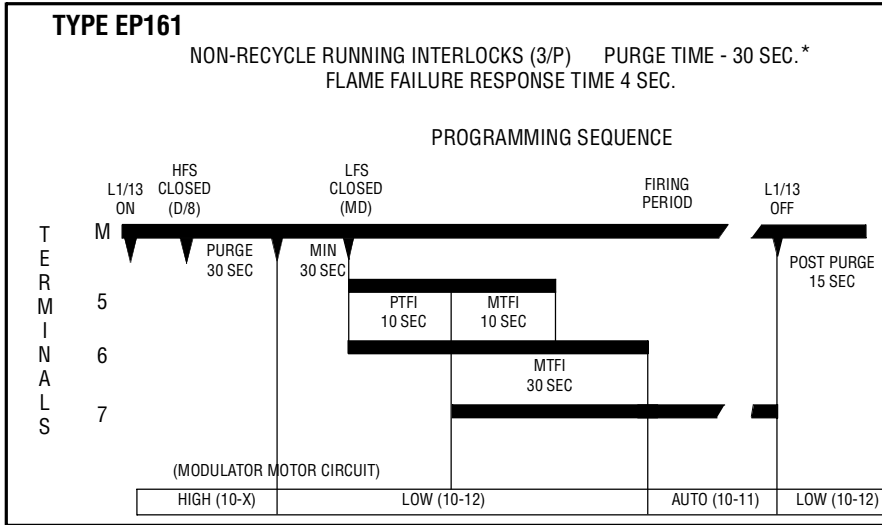

DIPSWITCH SETTINGS

1	2	3	4	5	6
INACTIVE		Down	Down	Down	Down

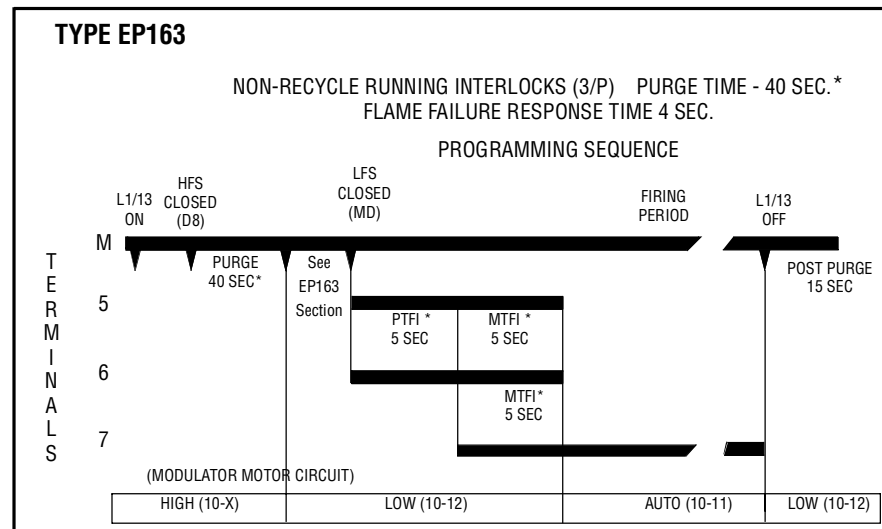

DIPSWITCH SETTINGS

1	2	3	4	5	6
ALL SETTINGS ARE INACTIVE					

* Factory default values are shown.
 * PURGE, PTFI, MTFI, and Post Purge timings are programmable via ED510 display. Refer to EP163 section of this bulletin.

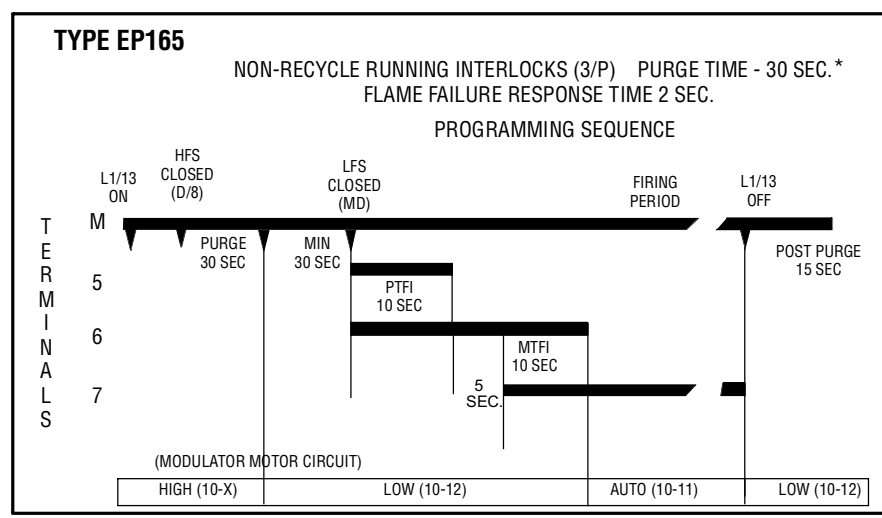

DIPSWITCH SETTINGS

1	2	3	4	5	6
INACTIVE		Down	Down	Down	Down

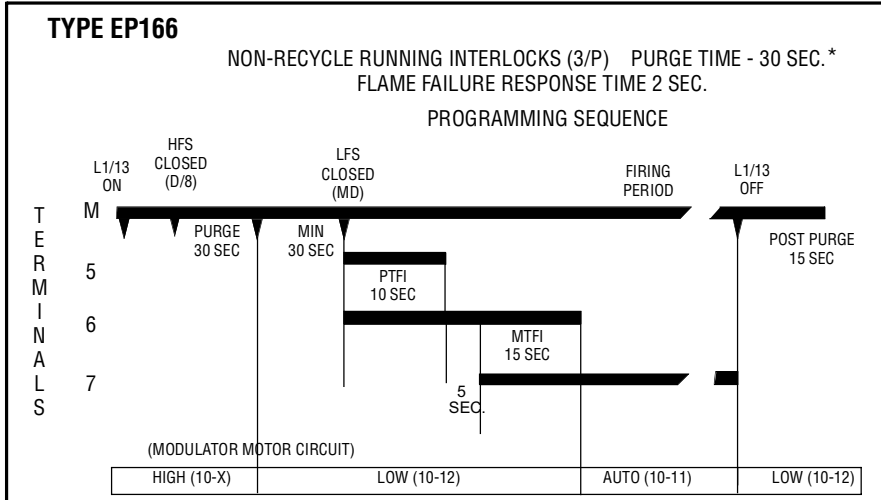

DIPSWITCH SETTINGS

1	2	3	4	5	6
INACTIVE	INACTIVE	Down	Down	Down	Down

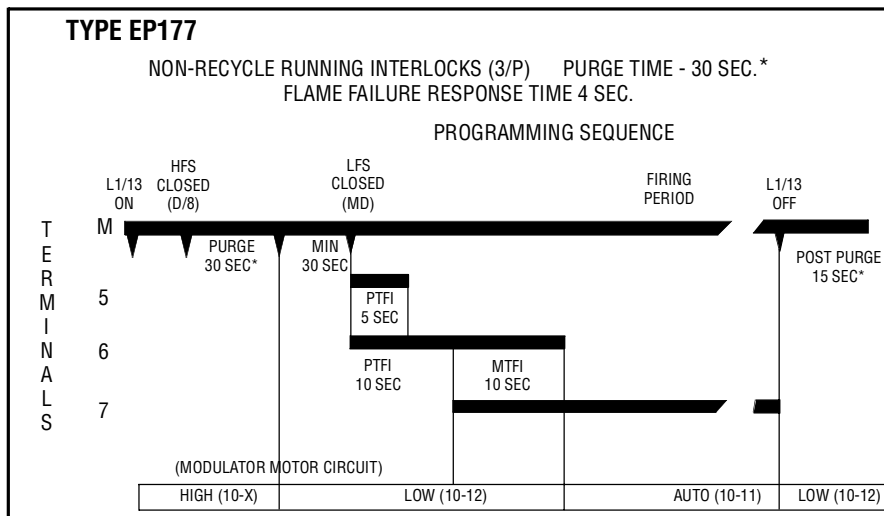

DIPSWITCH SETTINGS

1	2	3	4	5	6
ALL SETTINGS ARE INACTIVE	ALL SETTINGS ARE INACTIVE	ALL SETTINGS ARE INACTIVE	ALL SETTINGS ARE INACTIVE	ALL SETTINGS ARE INACTIVE	ALL SETTINGS ARE INACTIVE

* Factory default values are shown.
 * PURGE, PTFI, MTFI, and Post Purge timings are programmable via ED510 display. Refer to EP177 section of this bulletin.

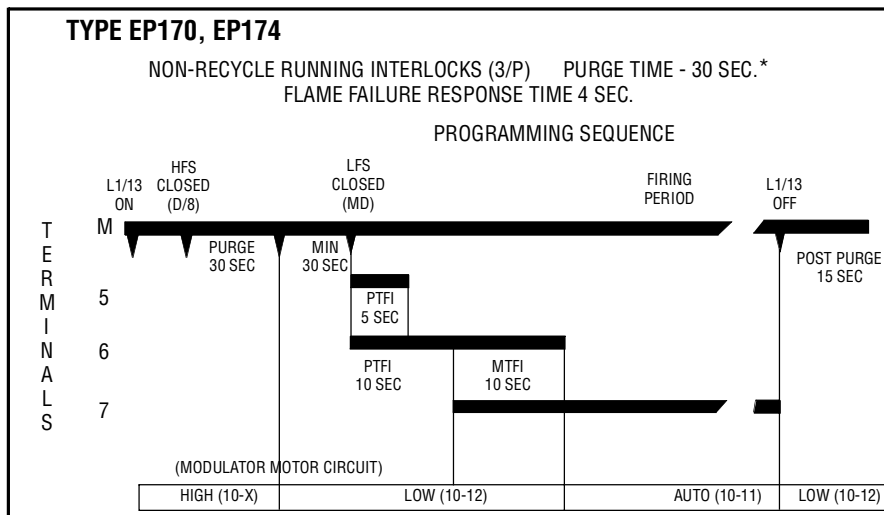

DIPSWITCH SETTINGS

1	2	3	4	5	6
INACTIVE	INACTIVE	Down	Down	Down	Down



DIPSWITCHES FOR SELECTABLE OPERATION

Several operational characteristics of the EP160, EP161, EP165, EP166, EP170 and EP174 programmer modules are determined by six (6) dipswitches located on the side of the programmer. These characteristics include purge timing (dipswitches 3, 4, 5) and the option requiring the 3-P running interlock circuit to be proven open at the start of the operating cycle, and that the D-8 (Purge Interlock) and M-D (low fire start interlock) switches open and close at the appropriate times (dipswitch 6). Dipswitch 2 is inactive. (Refer to later sections in this bulletin describing the EP163 programmer).

In programmer models with engineering code 39 and above, for a PPC5000 to recognize a new cycle, dipswitch 1 now invokes a 3 second delay after the operating switch closes to when the blower motor, terminal M, becomes powered. On a quick recycle, this will all force terminal M to become de-energized for 3 seconds.



WARNING: THE INAPPROPRIATE SELECTION OR APPLICATION OF A PROGRAMMER MODULE COULD RESULT IN AN UNSAFE CONDITION HAZARDOUS TO LIFE AND PROPERTY. The various programmer modules (EP160, EP260, and EP380) are interchangeable because they plug into a common chassis. Changing the dipswitches modifies the operation of each programmer module. Care should be taken to insure the proper dipswitch settings. Selection of the programmer module and setting the dipswitches for a particular application should be made by a competent professional, such as a Boiler/Burner technician licensed by a state or other government agency, engineering personnel of the burner, boiler, or furnace manufacturer (OEM) or in performance of duties based on information from the OEM.

FRONT COVER

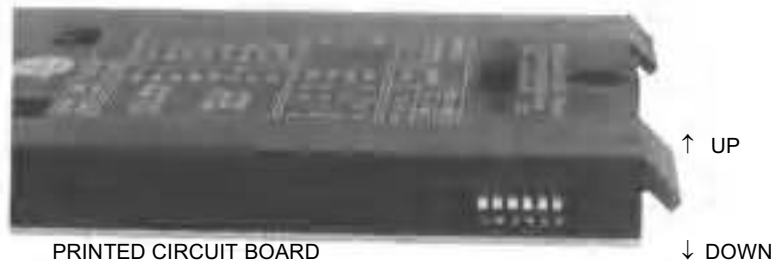

DIPSWITCHES - INACTIVE

DIPSWITCH 1 - FORCED BLOWER MOTOR START DELAY

When using a PPC5000 for boiler control operation, for the PPC5000 to recognize the beginning of a new burner operating cycle, it is necessary to force the blower motor (terminal M) off or non-powered for a short period of time. Placing dipswitch 1 in the UP position will delay the blower from starting 3 seconds after the operating control (terminal 13) closes or force the blower motor to de-energize for 3 seconds in the event of a quick recycle. The function of dipswitch 1 is not made permanent after 8 hours of operation.

DIPSWITCHES 3, 4, & 5 - PURGE TIMING

Dipswitches 3, 4, & 5 determine the purge timing for the programmer module. Purge timings are selectable from 30 seconds to 30 minutes. On the EP160, EP161, EP165, EP166, EP170 programmer, the purge timing is not initiated until the firing rate motor is driven to the high fire position (10-X made) and the high fire switch is proven closed (term D-8). At the end of the purge timing, the firing rate motor is driven to the low fire position (10-12), **and the control waits an additional 30 second (minimum) until the low fire start interlock is proven closed (M-D)**. Refer to the table on dipswitch functions to select the various purge timing.



DIPSWITCH 6 (3-P), (D-8), (M-D) INTERLOCK CHECK*

Dipswitch 6 provides the option to require that the 3-P, D-8, and M-D interlock circuits be proven closed *and open* at the appropriate times.

1. If this option is enabled (switch 6 is up) the **3-P** Running Interlock circuit must be **proven open** at the start of the operating cycle (when the L1-13 circuit first closes). If the 3-P circuit is closed at the start of the operating cycle, the blower motor will not energize (terminal M), and the control will "Hold" for one (1) minute waiting for the 3-P circuit to open. If, after one minute, the 3-P circuit does not open, the control will lockout. If, within one minute the 3-P circuit does open, the blower motor will energize (terminal M), and the control will wait up to ten (10) seconds for the 3-P circuit to be **proven closed**.
2. If this option is enabled (switch 6 is up), the **D-8** High-Fire Purge interlock circuit must be **proven open** at the start of purge before the Flame-Monitor™ will drive the firing rate motor to the high-fire position, (at which time the switch must then be **proven closed**). If the D-8 interlock circuit is closed at the start of the purge period, the control will "Hold" for ten (10) seconds, then lockout.
3. If this option is enabled (switch 6 is up), the **M-D** Low-Fire-Start interlock circuit must be **proven open** at the end of high-fire purge before the Flame-Monitor will drive the firing rate motor to the low-fire position, (at which time the switch must then be **proven closed**). If the M-D interlock circuit is closed at the end of the high-fire purge period, the control will "Hold" for ten (10) seconds, then lockout.

*Note: If a particular installation does not have operational switches in **all three** circuits listed above, (such as an installation where there is no High-Fire -Purge switch installed, and a **permanent** jumper is wired between terminals D-8), dipswitch 6 **should not** be enabled.*

*The EP160, EP161, EP165, EP166, EP170 programmers are shipped with this option disabled (switch 6 is down).



DESCRIPTION OF DIPSWITCH FUNCTIONS

DIPSWITCH POSITION						PROGRAMMER TYPE	TERMINAL TIMINGS				
Up = UP		DN = DOWN					PTFI		MTFI		
1	2	3	4	5	6		T-5	T-6	T-5	T-6	
FORCE DELAY	INACTIVE					EP160	10	10	10	15	
							EP170	5	10	—	10
							EP161	10	10	10	30
							EP165	10	10	—	10*
							EP166	10	10	—	15*
		Dn	Dn	Dn			30 sec.	SELECTABLE HIGH FIRE PURGE TIMING Low Fire Purge Timing added to selected purge — 30 sec. (minimum)			
		Dn	Dn	Up			60 sec.				
		Dn	Up	Dn			90 sec.				
		Dn	Up	Up			2 min.				
		Up	Dn	Dn			5 min.				
Up	Dn	Up			10 min.						
Up	Up	Dn			15 min.						
Up	Up	Up			30 min.						
				Dn	Prove 3-P Open	DISABLED					
				Up	Prove 3-P Open	ENABLED					

* During MTFI, terminal 6 remains energized for 5 sec. (pilot stabilization) before energizing terminal 7 for 10 sec (EP165), or for 15 sec. (EP166 only).

PROGRAMMER AND DISPLAY MODULE COMPATIBILITY

Two display modules are available for the FLAME-MONITOR control system (P/N's ED500 and ED510). The ED500 is an 8 character LED display that physically mounts in the card rack of the EB700 chassis. The ED510 is a 2 line by 16 character LCD with keypad to provide both current and historical information pertaining to the operation of the control. The ED510 display physically mounts onto the front cover of the programmer module. Refer to Bulletin ED5101 for a complete description of the features and capabilities of the ED510 display module. Programmers with an Engineering code of 28 or later (e.g.: 9414-28) are compatible with both the ED510 and ED500 display module. Programmers with an Engineering code before 28 are only compatible with the ED500 display.

IMPORTANT INFORMATION — PLEASE READ CAREFULLY

DETECTING AIR FLOW SWITCH (3-P) CLOSED AFTER START

In code 39 programmers and above, the method used to detect the air flow switch closed at the beginning of a cycle has been changed to avoid any nuisance lockouts. Currently, after the operating control closes, the programmer waits 10 seconds for the air flow switch to close and if not closed will go into lockout. The EP programmers utilize the open damper switch interlock, D-8, to determine the wait time for the air flow switch to close. If, at the start of a cycle after a blower turns on, the D-8 interlock is detected as closed, most likely indicating a jumped high fire switch, the programmer allows 20 seconds for the air flow switch to close. Alternatively, at startup, if the D-8 interlock is open, indicating the firing rate motor is at the low fire position and the damper is closed, the programmer will not check for the air flow switch closed until 10 seconds after the open damper switch has closed and the purge period has begun. This means the programmer will send the mod motor to the high fire position, forcing the high fire damper switch to close, and will then begin its 10 second timer to check for the air flow switch to close.



PERMANENT BURN-IN OF DIPSWITCH FUNCTIONS

The EP Programmer modules have a set of six (6) dipswitches on the side of the programmer to modify various functions associated with the operation of the programmer (e.g. purge timing, prove 3-P circuit open to start, etc.). **THESE FUNCTIONS BECOME PERMANENT AFTER THE CONTROL HAS BEEN POWERED FOR EIGHT (8) HOURS.*** After this burn-in period, changing position of the dipswitches will not change the operation of the programmer.

Note: The function of dipswitch 1 is not stored.

The user can bypass the burn-in period via the ED510 display module. Use the SCROLL and MODE key to select the “Programmer Set-Up” Sub-Menu (Refer to bulletin ED-5101) and then the SCROLL key to display the prompt:

**PRESS RESET TO
ACCEPT SETTINGS**

Press the Reset key at this prompt and the screen will display:

**YOU AGREED TO
ACCEPT SETTINGS**

After the above key sequence is completed, changing the position of the dipswitches will not change the operation of the programmer.

PROGRAMMING THE EP163 PROGRAMMER MODULE

The EP163 Programmer Module provides a number of operational characteristics that are selected via the ED510 Keypad/Display rather than by dipswitch selection. The following is a list of the programmable functions associated with the EP163 Programmer Module:

- Selectable purge (selectable from 6 seconds to 40 seconds in 2 second increments - default setting is 40 seconds).
- Prove the operation of the 3-P Running Interlock Circuit.
- Prove the operation of the High Fire Purge Interlock (D-8).
- Prove the operation of the Low Fire Start Interlock (M-D).
- Selectable timings on terminals 5 and 6 during Pilot Trial For Ignition (PTFI).
- Selectable timings on terminals 5 and 6 during Main Trial For Ignition (MTFI).
- Selectable Post Purge Timing of 1 or 15 seconds.

MODIFYING THE PROGRAMMER

1. Insert the EP163 programmer module into the EB700 chassis and connect the ED510 Keypad/Display.
2. Open the operating control (L1-13) circuit. The EP163 cannot be modified unless the operating control is open.
3. The PROGRAM SETUP sub-menu will be used to display the programmable functions. Press the SCRL key until the PROGRAM SETUP sub-menu is displayed.
4. Press the MODE key to enter the PROGRAM SETUP sub-menu. The SCRL key will advance through the selections in the sub-menu. The first four items displayed in the sub-menu are PROGRAMMER TYPE EP163, ENGR CODE, AMPLIFIER TYPE, and FFRT TIME 4 S. These items are not programmable.
5. Press the SCRL key and the next item displayed (and first programmable item) is PURGE TIME followed by the current setting (default setting = 40 seconds). The available purge timings are from 6 to 40 seconds, in 2 second increments.
6. Press and hold the RESET button for 1 second to enter the “Modify” mode (providing the control was not in a lockout condition). After a 2-3 second delay, the control will display SCRL TO MODIFY on the top line of the display (replacing STANDBY).

*Programmer module EP163 has a fifty (50) hour burn-in period.



7. Press the SCRL key to advance through the allowable selections. The selections will roll over from the last selection to the first one.
8. Press and hold the RESET button for one second to choose and store in memory the appropriate selection.

Note: Following the purge period, the EP163 will initiate PTFI as soon as the M/D circuit closes (eliminating the 30 seconds minimum wait period).

9. The SCRL key will advance through the following selections. Follow steps 1 through 8 to modify the selections.
10. PROVE 3-P OPEN Y
Available selections are Yes (Y) and No (N). Yes is the default selection. If selected Y, at the start of the operating cycle, the control will check to see if the 3-P circuit is open before energizing the blower motor. If closed, the control will hold for 60 seconds and then lockout.
11. PROVE D-8 OPEN N
Available selections are Yes (Y) and No (N). No is the default selection. If selected Y, the control will check to see if the D-8 circuit is open before driving the firing rate motor to the high fire position (10-X). If closed, the control will hold for 60 seconds and then lockout.
12. PROVE M-D OPEN Y
Available selections are Yes (Y) and No (N). Yes is the default selection. If selected Y, the control will check to see if the M-D circuit is open at the end of the purge period before driving the firing rate motor to the low fire position (10-12). If closed, the control will hold for 60 seconds and then lockout.
13. PTFI TIMING 5 SEC
This selects the timings for terminals 5 and 6 during Pilot Trial For Ignition (PTFI). Available selections are 5 and 10 seconds. The default value is 5 seconds. Timing selection applies to both terminal 5 and 6. The control will begin MTFI as soon as flame is detected (following 2 second check at the start of PTFI). For example, 3 seconds into PTFI, flame signal detected, terminal 7 is energized.



CAUTION: Main fuel valve (terminal 7) will be powered as soon as PILOT FLAME IS DETECTED.

14. MTFI TIMING 5/5
This selects the timings of terminals 5 and 6 during Main Trial For Ignition (MTFI). The first number represents terminal 5, the second number represents timing associated with terminal 6. Available selections are: 0/5, 5/5, 0/10, 5/10, 10/10, 0/15, and 10/15. Default value is 5/5.
15. POST PURGE 15
Available selections are 15 seconds and 1 second. Default value is 15 seconds.



CAUTION: PER UL 296, A MECHANICAL DRAFT BURNER HAVING AN INPUT IN EXCESS OF 20 GPH (76 L/H) SHALL PROVIDE A POST-PURGE PERIOD OF NOT LESS THAN 15 SECONDS.

16. UNIT ADDRESS 00
Available selections are 00 through 15. Default selection is 00.
17. ACCEPT SETTINGS N
Available selections are Yes (Y) and No (N). No is the default selection. If selected Y, the system will accept the current settings (overriding the 50 hour normal burn-in time). If selected No, the settings will be permanently burned in after a 50 hour burn-in period. After the 50 burn-in time, the settings will not be able to be changed.
18. Press the MODE key to return to the run message.



WARNING: THE INAPPROPRIATE SELECTION OR APPLICATION OF A PROGRAMMER MODULE COULD RESULT IN AN UNSAFE CONDITION HAZARDOUS TO LIFE AND PROPERTY. Care should be taken to ensure the proper selection for each setting. Selection of the settings for a particular application should be made by a competent professional, such as a Boiler/Burner technician licensed by a state or government agency, engineering personnel of the burner, boiler, or furnace manufacturer (OEM), or in performance of duties based on information from the OEM.



PROGRAMMING THE EP177 PROGRAMMER MODULE

The EP177 Programmer Module provides a number of operational characteristics that are selected via the ED510 Keypad/Display rather than by dipswitch selection. The following is a list of the programmable functions associated with the EP163 Programmer Module:

- Selectable purge (selectable from 6 seconds to 40 seconds in 2 second increments - default setting is 40 seconds).
- Prove the operation of the 3-P Running Interlock Circuit.
- Prove the operation of the High Fire Purge Interlock (D-8).
- Prove the operation of the Low Fire Start Interlock (M-D).
- Selectable timings on terminals 5 and 6 during Pilot Trial For Ignition (PTFI).
- Selectable timings on terminals 5 and 6 during Main Trial For Ignition (MTFI).
- Selectable Post Purge Timing of 1 or 15 seconds.

MODIFYING THE PROGRAMMER

1. Insert the EP177 programmer module into the EB700 chassis and connect the ED510 Keypad/Display.
2. Open the operating control (L1-13) circuit. The EP177 cannot be modified unless the operating control is open.
3. The PROGRAM SETUP sub-menu will be used to display the programmable functions. Press the SCRL key until the PROGRAM SETUP sub-menu is displayed.
4. Press the MODE key to enter the PROGRAM SETUP sub-menu. The SCRL key will advance through the selections in the sub-menu. The first four items displayed in the sub-menu are PROGRAMMER TYPE EP163, ENGR CODE, AMPLIFIER TYPE, and FFRT TIME 4 S. These items are not programmable.
5. Press the SCRL key and the next item displayed (and first programmable item) is PURGE TIME followed by the current setting (default setting = 30 seconds).
6. Press and hold the RESET button for 1 second to enter the "Modify" mode (providing the control was not in a lockout condition). After a 2-3 second delay, the control will display SCRL TO MODIFY on the top line of the display (replacing STANDBY).
7. Press the SCRL key to advance through the allowable selections. The selections will roll over from the last selection to the first one.
8. Press and hold the RESET button for one second to choose and store in memory the appropriate selection.
9. The SCRL key will advance through the following selections. Follow steps 1 through 8 to modify the selections.

The program sequence timings of the EP177 are the same as the EP170 programmer.

The EP177 provides the following adjustments made via the ED510 keypad.

PURGE TIME 30s, 1m, 3m, 5m, 7m, 9m, 10m, 12m, 15m, 16m, 18m, 20m, 22m, 25m,
27m, 30m, 32m, 35m, 37m.

default is 30s

Pre-purge time begins after the open damper proving switch (8) is detected closed.

PROVE 3-P OPEN Y/N **default is N**

The non-recycling interlocks wired between terminals 3 and P must be open at the start of a cycle.

TERMINAL 6 = INTRP/INTMT **default is INTRP (interrupted)**

The pilot valve terminal can be set for interrupted or intermittent operation. If intermittent (INTMT), terminal 6 will remain energized during the firing cycle.



RJ STYLE CONNECTORS

ED510 Display - See Bulletin ED-5101

Programmer modules (with Engineering code 28 or later) include an RJ45 style connector to connect to an alpha-numeric display (P/N ED510). The ED510 can snap onto the front cover of the programmer module or be mounted remotely (See Bulletin E-8101— Remote mounting kit). The ED580 cable (provided with ED510 Display) then plugs into the RJ45 style connectors on both the ED510 display and programmer module.

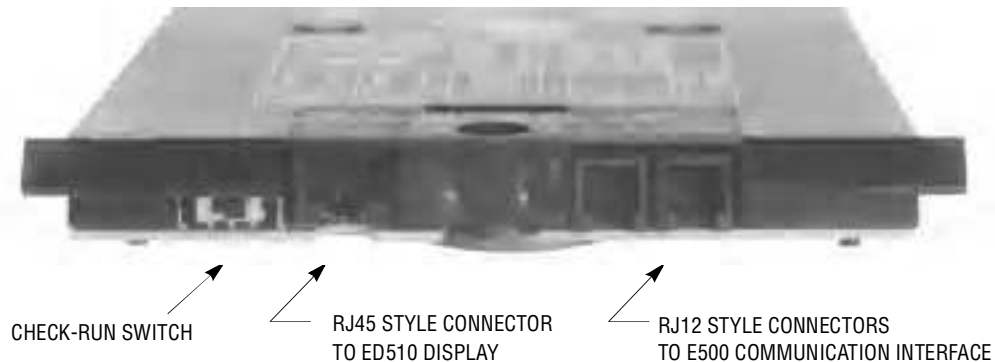

Check-Run Switch

The Check-Run switch is located on the top of the EP Programmer Module and can be used to stop the control in its firing sequence at any time except MTFI. If moved during the MTFI period, it is not functional and automatic programming continues. It aids in the set-up and adjustment of the burner linkages, pilot assembly, etc. Refer to Bulletin E-1101 for a complete description of the Check-Run Switch.

E500 Communication Interface and InTouch Wireless Monitoring System

Programmer modules include two (2) RJ12 style connectors to connect to the RS485 Interface on the E500 Communication Interface or InTouch Wireless Monitoring System in a multi-drop wiring configuration with other devices or connect to a Modbus network. Refer to Bulletin E-5001 and INT-1000 respectively. Up to six (6) each of EP programmers and E340 Boiler Controls (12 total) can be wired in an E500 multi-drop configuration or up to ten (10) to the InTouch. (Unit address 00 to 31). When connected in this manner, a unit address must be set on each programmer module connected to the RS485 interface. (See Unit Address). Programmers can also be connected to the E500 via the standard flat ribbon cables (ED550).



UNIT ADDRESS

There are two methods to program the unit address when the programmer module is connected to the E500 via the RS485 interface:

Method One (ED510 display only)

1. Press the SCRL key until the screen displays PROGRAM SETUP
2. Press the MODE key and the screen displays PROGRAMMER EP160 (or appropriate model).
3. Press the SCRL key until the screen displays UNIT ADDRESS #00 (or appropriate address).
4. Every time the RESET key is held down for 1 second and then released will increase the address by one.
5. Maximum address is 31. Then the address will roll over to 00.

Method Two (ED510 or ED500)

1. Make sure the control is not in a lockout condition. If so, press the reset button.
2. Open the operating control (term L1-13).
3. Move the "Check-Run" switch to the Check position.
4. The display will indicate Unit Address 00 (or the current address).
5. Every time the reset button is held down for 1 second and then released will increase the address by one.
6. Maximum address is 31. Then the address will roll over to 00.

FLAME-MONITOR MODBUS COMMUNICATIONS

The protocol to be used is Modbus RTU. This is implemented by the master (PC, PLC, etc.) issuing a poll to the slave (Flame-Monitor) and the slave responding with the appropriate message.

A typical format of a poll request is as follows:

DST	FNC	ADR HI	ADR LO	DAT HI	DAT LO	CRC LO	CRC HI
-----	-----	-----------	-----------	-----------	-----------	-----------	-----------

DST refers to the logical address of the slave.

FNC is the function being requested. FNC 03 is a read request.

ADR is the message number or register number of the data being requested. In Modbus, register addresses begin at 40001 but is interpreted as address 00.

DAT is the number of words being requested. A word is an integer consisting of 2 bytes.

The normal response from a slave is as follows:

DST	FNC	DBC	DATA... HI/LO	CRC LO	CRC HI
-----	-----	-----	------------------	-----------	-----------

DBC is the data byte count being returned. It must be two times the DAT number from the poll request.

DATA is the data returned and is always a series of 2 byte integers. If 4 words were requested then DBC would be 8 and there would be 8 data bytes or 4 data words containing the requested data.

The format of the data is 4800,N,8,1 meaning 4800 baud, no parity, and 1 stop bit.

Below is a table of currently available messages provided by the Flame-Monitor programmers, followed by a description where necessary.



Table 1:

MESSAGE ADDRESS	WORD REQUESTED	RESPONSE	VALUE
00	1-6	STATUS	83 (053H) = RUN; 202 (0CAH) = LOCKOUT
01	1	MSGN	Current message being displayed (see Table 3)
02	1	GSTAT	Defines Timer Type
03	1	TIMER	Time, Flame, Address
04	1	FLAME	Flame Signal
05	1-3	LOGSTAT	Current logic module, PURGE, PTFI, AUTO (see Table 2)
06	1	INPUTS	Input limits state
07	1	OUTPUTS	Output relays state
08	2	SYSMINS	System on minutes
10	2	BNRMINS	Burner on minutes
12	2	CYCLES	Completed Burner Cycles
14	1	LOCKOUT COUNT	Stored Lockout Count
15	1-6	LOCKOUT HISTORY	Last 6 Lockouts, first word is most current lockout
21	1-2	DEV TYP	Programmer device type, 5=EP, 6=EPD, 7=MicroM
22	1	AMPTYP	Amplifier Type; EUVS4=0C0H; EIR1=0A0H; ERT1, EUV1=090H;
MESSAGE ADDRESS	WORD REQUESTED	RESPONSE	VALUE
23			Not Used
24	2	FLAME SIGNAL AVERAGES	PTFI and Auto Flame Signal Averages
26	1-9	Combined status	See Description Below
35	6	Most Recent Lockout Data	Returns complete lockout description of stored lockout history. Includes lockout message, lockout module, @ burner hours, and @ burner cycles
41	6	2nd Most Recent Lockout Data	
47	6	3rd Most Recent Lockout Data	
53	6	4th Most Recent Lockout Data	
59	6	5th Most Recent Lockout Data	
65	6	6th Most Recent Lockout Data	
71	1-3	Input limits and Expansion Module registers	Returns input limits state and lower and upper expansion module (E300) registers. See Table 3
72	1-2	Expansion Module (E300) registers	Returns lower and upper Expansion module registers
73	1		Return only upper Expansion module register

It is suggested that polling intervals not be less than 200 mSec per request. Requesting data such as burner minutes, system minutes and burner cycles should be kept at a minimum due to the amount of processing time required to gather that data.

Messages 00, 05, 08, 10, 15, 21 and 26 are unique in that a limited number of successive registers can be combined with these requests. For example, a request to message 00 can contain up to 6 data words. The response to this would contain STATUS, MSGN, GSTAT, TIMER, FLAME and LOGSTAT. If the requested data word count (DAT) were to be 2 then the response would contain STATUS and MSGN only. Message 15, last 6 lockouts, can return data ranging from 1 to 6, with 1 referring to the most recent lockout.



The MSGN being transmitted is a numerical value and must be interpreted by the communicating device, which actually is an advantage since this can be made to be whatever message text the end user wants. In other words, it allows for programming custom messages without actually changing the message in the programmer. Refer to Table 3 for message information.

Message 26 returns the current operating status as well as stored burner hours and burner cycles as a snapshot of the entire Flame-Monitor system. When all 9 words are requested, the data returned consists of STATUS, MSGN, FLAME, INPUTS, OUTPUTS, BNRMINS, and BNRCYCS

The Flame-Monitor stores its burner on time and system on time (L1 powered) in minutes. For display purposes, the programmer converts this to hours. The information being supplied by Modbus will be the actual time in minutes and it is up to the communicating device to do the conversion. Since the maximum value stored in the Flame-Monitor is 9,999,999 minutes, the maximum value in hex therefore is 98967FH and comprises two data words. The maximum cycle count is 999,999 decimal or F423FH, still two data words. As an example, the System on Minutes data is transmitted from the Flame-Monitor to the interface as high word / low word as shown below:

Address 8		Address 9	
High Word		Low Word	
High Byte	Low Byte	High Byte	Low Byte
0	98H	97H	7FH

Note: Data from address 9 cannot be accessed directly.

All values are represented in a HEX or base 16 format.

GSTAT determines the type of value TIMER represents. TIMER can be a running timer such as is used in purge, a flame signal or meaningless. Only the lower nibble of GSTAT has any value. If this value is 0 then the TIMER value has no meaning. The value in TIMER is a background minute timer in the Flame-Monitor and should be ignored. If GSTAT is between 4 and 7, the TIMER represents the current value flame signal. If GSTAT is a 1, 2, or 3 then TIMER represents a running timer value.

The baud rate of the Flame-Monitor is fixed at 4800 bits per second. The format of the data is 8 data bits, no parity and 1 stop bit. Due to the RS485 format, the communication format is considered half-duplex. That is, only one user is permitted on the communication lines at a time.

The information contained in INPUTS and OUTPUTS represents the status of the interlocks and relays respectively. For the INPUTS, a 1 in the interlock position defines the interlock as being on or active where a 1 in any bit position in the OUTPUT register signifies the relay as being energized.

INPUTS

Bit 7							Bit 0
Term P	Term 5/6	Term D		Term 8	Term 7	Term 3	Term 13
Air Flow	Ignition	Low Fire	Ref	High Fire	Main Fuel	FVES or POC	Op Ctrl

A '1' in the opto-coupler position indicates the opto-coupler is on or interlock closed.

Expansion Module (E300) Lower

Term 35	Term 34	Term 33	Term 32	Term 23	Term 22	Term 21	Term 20
Aux #6	Aux #5	Aux #4	High Temp	High Water	Main Fuel	FVES or POC	Op Ctrl

Expansion Module (E300) Upper

Term 31	Term 30	Term 29	Term 28	Term 27	Term 26	Term 25	Term 24
High Pressure	Low Gas Pressure or Low Atomizing Media	Low Oil Temp.	Low Oil Pressure	High Gas Pressure	Oil Selected	Gas Selected	Low Water

OUTPUTS

Term 11	Term M	Term 6		Term 5	Term 7	Term A	Term X
Auto (RA1)	Blower (RB)	Ignition (RA2)	FVES (RV)	Pilot (RP)	Main Fuel (RF)	Alarm (RL)	High Fire (RH)

Refer to Fireye bulletin E-1101 for terminal designations.



LOGSTAT is an indication of what logic module the control is currently operating in during its cycle and is used for diagnostic purposes only. If a lockout occurs the current value of LOGSTAT is stored as part of the lockout information. The message displayed corresponds to the current logic module.

Table 2:

EXPLANATION OF LOGSTAT

LOGIC DISPATCHER			
VALUE		MODULE	FUNCTION
DEC	HEX		
69	45H	MPOSTIDLE	ENERGIZING BLOWER MOTOR
70	46H	MPREPURGE1	WAIT FOR AIR FLOW AND/OR HIGH FIRE SWITCH TO CLOSE
71	47H	MPURGE	OPEN DAMPER PURGE
72	48H	MPOSTPURGE	LOW FIRE START
73	49H	MTFI	PILOT TRIAL
74	4AH	MTFMF	MAIN TRIAL
75	4BH	MAUTO	AUTO
76	4CH	MSHTDWN1	POST PURGE
77	4DH	MSHTDWN2	POST PURGE
78	4EH	MIDLE	STANDBY

Logstat represents the current software module the Flame-Monitor is currently executing. They are named as close to the logic module the actual burner sequence is in. For instance, in the Flame-Monitor, MPURGE represents High Fire Purge where MPOSTPURGE represents the low fire start period where the mod motor is sent to the low fire position in preparation for pilot light-off. MSHTDWN1 represents the post purge period after a complete cycle or the cool down period after a lockout.

MIDLE or STANDBY is the period of time where the operating control is open or the control is in lockout waiting for reset. On instances of false flame during the purge period, the control algorithm forces the control back to STANDBY until false flame ceases or lockout occurs.

MPREPURGE1 is the period of time prior to PURGE where the control checks the status of the air flow interlocks or the high fire proving switch (D-8). If either switch is found open, the control will remain in this state until the respective switch closes or lockout occurs.

P-MTFI represents the pilot trial for ignition stage of a burner sequence. MTFMF represents the main trial for main flame period where main fuel is introduced along with pilot and igniter.

MAUTO is the run period of the burner sequence.

MPOSTIDLE and MSHTDWN2 are small periods of time where certain internal tests are conducted and general cleanup before and after a cycle is performed.

The Flame-Monitor outputs the current displayed message as well as the historical lockout messages as numbers. The table below correlates the message number with the actual displayed test message.

Table 3:

DEC	HEX	E110 FLAME-MONITOR MESSAGES
1	1	L1-13 OPEN
2	2	FALSE FLAME - STANDBY
3	3	LOW FIRE PURGE
4	4	D-8 LIMIT OPEN - HOLD
5	5	3-P AIR FLOW OPEN - HOLD
6	6	LINE FREQUENCY NOISE DETECTED
7	7	FLAME FAIL - PTFI
8	8	UNIT ADDRESS
9	9	M-D LIMIT OPEN - HOLD
10	A	IGNITION TIMING
11	B	MTFI
12	C	FLAME SIGNAL - AUTO



DEC	HEX	E110 FLAME-MONITOR MESSAGES
13	D	CYCLE COMPLETE
14	E	L1-13 OPEN
15	F	AC POWER FAIL (COEN)
16	10	SHORT CIRCUIT TERMINAL 5, 6 or 7
17	11	D-8 LIMIT OPEN - LOCKOUT
18	12	M-D LIMIT OPEN - LOCKOUT
19	13	FLAME FAIL - MTFI
20	14	FALSE FLAME - LOCKOUT
21	15	LOCKOUT 3-P INTLK OPEN (PURGE)
22	16	3-P INTLK CLOSED - LOCKOUT
23	17	3-P INTLK CLOSED -HOLD
24	18	HIGH FIRE PURGE
25	19	PLEASE WAIT
26	1A	LOCKOUT 3-P INTLK OPEN -AUO
27	1B	LOCKOUT 3-P INTLK OPEN (MTFI)
28	1C	LOCKOUT 3-P INTLK OPEN (PTFI)
29	1D	LOCKOUT 13-3 FVES OPEN
30	1E	FALSE FLAME - LOCKOUT
31	1F	FLAME SIGNAL - CHECK PTFI
32	20	D-8 HI LIMIT - CHECK
33	21	M-D low LIMIT CHECK - AUTO
34	22	FLAME SIGNAL - PTFI
35	23	LOW FIRE SIGNAL - CHECK AUTO
36	24	FLAME SIGNAL - MTFI
37	25	FLAME FAIL - AUTO
38	26	3-P INTLK OPEN - HOLD PURGE
39	27	FUEL VALVE STATE CHANGE
E300 EXPANSION MODULE MESSAGES		
40	28	3-P AIR FLOW OPEN
41	29	3-P HIGH WATER
42	2A	3-P LOW WATER
43	2B	3-P HIGH GAS PRESSURE
44	2C	3-P LOW GAS PRESSURE
45	2D	3-P LOW OIL PRESSURE
46	2E	3-P LOW OIL TEMPERATURE
47	2F	3-P LOW ATOMIZING MEDIA
48	30	3-P HIGH STEAM PRESSURE
49	31	3-P HIGH TEMPERATURE
50	32	3-P AUX #4 OPEN
51	33	3-P AUX #5 OPEN
52	34	3-P AUX #6 OPEN
53	35	3-P FUEL SELECT
54	36	LOCKOUT CHECK CHASSIS
55	37	LOCKOUT CHECK PROGRAMMER
56	38	LOCKOUT CHECK AMPLIFIER
57	39	LOCKOUT CHECK EXPANSION MODULE
58	3A	LOCKOUT AMPLIFIER AUTO CHECK FAIL
59	3B	LOCKOUT SCANNER NOISE



DEC	HEX	E110 FLAME-MONITOR MESSAGES
E300 EXPANSION MODULE HOLD MESSAGES		
60	3C	L1-13 AUX #1 OPEN (TERMINAL 20)
61	3D	L1-13 AUX #2 OPEN (TERMINAL 21)
62	3E	L1-13 AUX #3 OPEN (TERMINAL 22)
63	3F	3-P HIGH WATER (TERMINAL 23)
64	40	3-P LOW WATER (TERMINAL 24)
65	41	3-P HIGH GAS PRESSURE
66	42	3-P LOW GAS PRESSURE
67	43	3-P LOW OIL PRESSURE
68	44	3-P LOW OIL TEMPERATURE
69	45	3-P LOW ATOMIZING MEDIA
70	46	3-P HIGH PRESSURE (TERMINAL 31)
71	47	3-P HIGH TEMPERATURE (TERMINAL 32)
72	48	3-P AUX #4 OPEN (TERMINAL 33)
73	49	3-P AUX #5 OPEN (TERMINAL 34)
74	4A	3-P AUX #6 OPEN (TERMINAL 35)
75	4B	3-P FUEL SELECT
76	4C	LOCKOUT CHECK SCANNER
77	4D	HOLD D-8 LIMIT CLOSED
78	4E	LOCKOUT D-8 LIMIT CLOSED
79	4F	HOLD M-D LIMIT CLOSED
80	50	LOCKOUT M-D LIMIT CLOSED
81	51	LOCKOUT 13-3 POC CLOSED (CB ONLY)
82	52	DYNAMIC CHECK (CB ONLY)

OPERATION

The EP160, EP161, EP163, EP165, EP166, EP170 and EP174 programmers provide the operator with a constant status indication as well as diagnostic information. Programmers with an Engineering code of 28 or later (e.g.: 9414-28) are compatible with either the ED510 (2 line x 16 character LCD display with keypad for local access to historical information) or ED500 (8 character LED display).^{*} For purposes of illustration for this bulletin, we will be looking at the EP160 Programmer functions and messages associated with the ED510 display module. The ED500 display messages will be abbreviated versions of those of the ED510. Refer to the suggestions shown in bulletin

E-1101 before proceeding to power the Fireye FLAME-MONITOR system. Items such as scanner installation, short circuit tests and safety information should be reviewed.



CAUTION: On initial power-up and on restarts following a power failure, the control will perform self-test diagnostics for 15 seconds.

Start-Up (Normal Cycle), EP160 Programmer

Note: For direct spark ignited oil burners, substitute the words Main-Oil Valve for Pilot Valve.

1. Constant 120 VAC should be wired to the L1-L2 terminals on the wiring base.
2. The operating control circuits (L1-13) will close, signaling the burner to start its firing sequence.
3. Assuming the fuel valve end switch (13-3) is closed, the burner/blower motor (terminal M) circuit is energized. The running interlock (limit) circuit (3-P) will close (e.g.: all limits, interlocks, etc. are proven).
4. The firing rate motor (Modulator Motor) is driven toward the high purge open damper position (10-X circuit made).

^{*}The EP163 programmer must be programmed via the ED510 display.



5. When the firing rate motor reaches its open damper position, the Hi Purge switch closes (D-8) and the prepurge interval of 30* seconds is initiated. The ED510 will display:

PURGE 00:05
HIGH FIRE PURGE

If the D-8 circuit does not close, the program will hold in this position for ten minutes waiting for it to close. If it does not, the control will lockout

6. When the prepurge is completed, the firing rate motor is driven toward the low purge damper position (10-12 circuit made). The ED510 will display:

PURGE 00:35
LOW FIRE PURGE

7. Following the minimum 30 second delay (to permit the firing rate motor to get to the low fire position), the control will wait for the low fire switch (M-D) to close. When it closes, the trial for ignition sequence will start. If after ten minutes, the M-D circuit is not closed, the control will lockout.

8. The trial for ignition period begins with Terminal 5 and 6 being energized simultaneously. This is known as PTFI (Pilot Trial for Ignition). The ED510 will display:

PTFI 00:02
IGNITION TIMING

This period is ten seconds in duration. If no flame is detected after ten seconds, the control will de-energize Terminals 5 and 6 and lockout. When flame is detected during this 10 second period, the ED510 will display

PTFI 20
FLAME SIGNAL

FLAME SIGNAL	
0-9	NOT ACCEPTABLE
10	MINIMUM ACCEPTABLE
20-80	NORMAL

9. With flame proven at the end of PTFI, the main flame trial for ignition (MTFI) period begins. Terminal 7 is energized. The ED510 will display:

MTFI 35
FLAME SIGNAL

Terminal 5 is de-energized 10 seconds later and Terminal 6 is de-energized after another 5 seconds.

10. The firing rate motor is now sent to the auto position (10-11 circuit made) and is under the command of the proportional controller. The ED510 will display:

AUTO 40
FLAME SIGNAL

NOTE: Trial-for-Ignition timings depend on the programmer selected. The timing charts in the beginning of this bulletin point out the differences in the various programmers.

Normal Shutdown

1. When the operating control circuit (L1-13) opens, the main fuel valve is de-energized. The firing rate motor is driven to the low purge position (10-12 circuit made).
2. Following a 15 second post purge, the burner/blower motor is de-energized.
3. The burner is now off and the ED510 will display

STANDBY
L1-13 OPEN

Burner history can be displayed by using ED510 keypad. See bulletin ED-5101.

*Prepurge timing is selectable via dipswitches.



ED510 BACKLIT DISPLAY

With current ED510's (Engineering code 3 or higher), the LED display backlight remains ON at all times. With earlier ED510 versions, the backlight will be lit when the L1-13 (operating control) circuit is closed, and OFF when the L1-13 circuit is open. With the earlier displays, depressing any key will light the display for three (3) minutes.

LOCKOUTS

When a safety shutdown occurs, the control will display a message indicating LOCKOUT and the reason for the lockout. The alarm circuit (Terminal "A") will be energized. The non-volatile memory will remember the status of the control even if a power failure occurs. By depressing the reset button on the display, the control can be reset. The button must be held down for one second and then released. Very little force is required to do this. Do not press hard.

Safety Shutdown

1. If the running interlock circuit does not close, the control will lockout and the blower motor will be de-energized. If the interlock circuit opens during a start-up or firing period, all fuel valves will be de-energized and the control will lockout.
2. If the proven high fire circuit (D-8) has not closed after a ten (10) minute "Hold" period at the start of prepurge, the control will lockout.
3. If the low fire start circuit (M-D) has not closed after a ten (10) minute "Hold" period at the end of prepurge, the control will lockout.
4. If dipswitch 6 is in the "Up" position (3-P prove open to start-enabled), and the 3-P circuit is closed at the start of the operating cycle, the control will hold for one (1) minute waiting for the 3-P circuit to open. If, after one (1) minute, the 3-P circuit does not open, the control will lockout.
5. If dipswitch 6 is in the "Up" position (D-8 prove open to start enabled), and the D-8 circuit is closed at the start of the purge period, the control will hold for ten (10) seconds waiting for the D-8 circuit to open. If, after ten (10) seconds, the D-8 circuit does not open, the control will lockout.
6. If dipswitch 6 is in the "Up" position (M-D prove open to start enabled), and the M-D circuit is closed at the end of high-fire purge period, the control will hold for ten (10) seconds waiting for the M-D circuit to open. If, after ten (10) seconds, the M-D circuit does not open, the control will lockout.
7. If pilot flame is not detected during the 10 second trial for ignition period, the pilot valve and ignition transformer will be de-energized and the control will lockout on safety.
8. If main flame is not detected at the end of the main flame trial for ignition period, all fuel valves will be de-energized and the control will lockout on safety.
9. If the main flame fails during a firing cycle, all fuel valves will be de-energized within 4 seconds after loss of flame signal, (2 seconds with programmers EP165, EP166) and the control will lockout on safety.
10. The EP165 and EP166 programmers will lockout on a power interruption.
11. If flame is detected when the operating control (L1-13) is open, the control will wait sixty (60) seconds and then lockout if flame is still present. If the operating control closes and flame is detected during purge, the blower motor (term M) remains energized and the purge sequence is put on hold. If the flame signal goes away within sixty (60) seconds, the control will proceed with a normal start-up. If flame signal is still present after sixty (60) seconds, the control will lockout.

NOTE: Manual Reset is required following any safety shutdown.

NOTE: Depressing and releasing the reset button during a cycle will cause the control to shut the burner down and recycle.

Lockout Messages

Refer to bulletins ED-5101 or E-1101 for a complete list of all ED510 display messages.



Lockout History

Lockout and burner history can be displayed by using the ED510 keypad and display. Refer to Bulletins ED-5101 or E-1101.

SUGGESTED WIRING DIAGRAM FOR EP1XX PROGRAMMERS

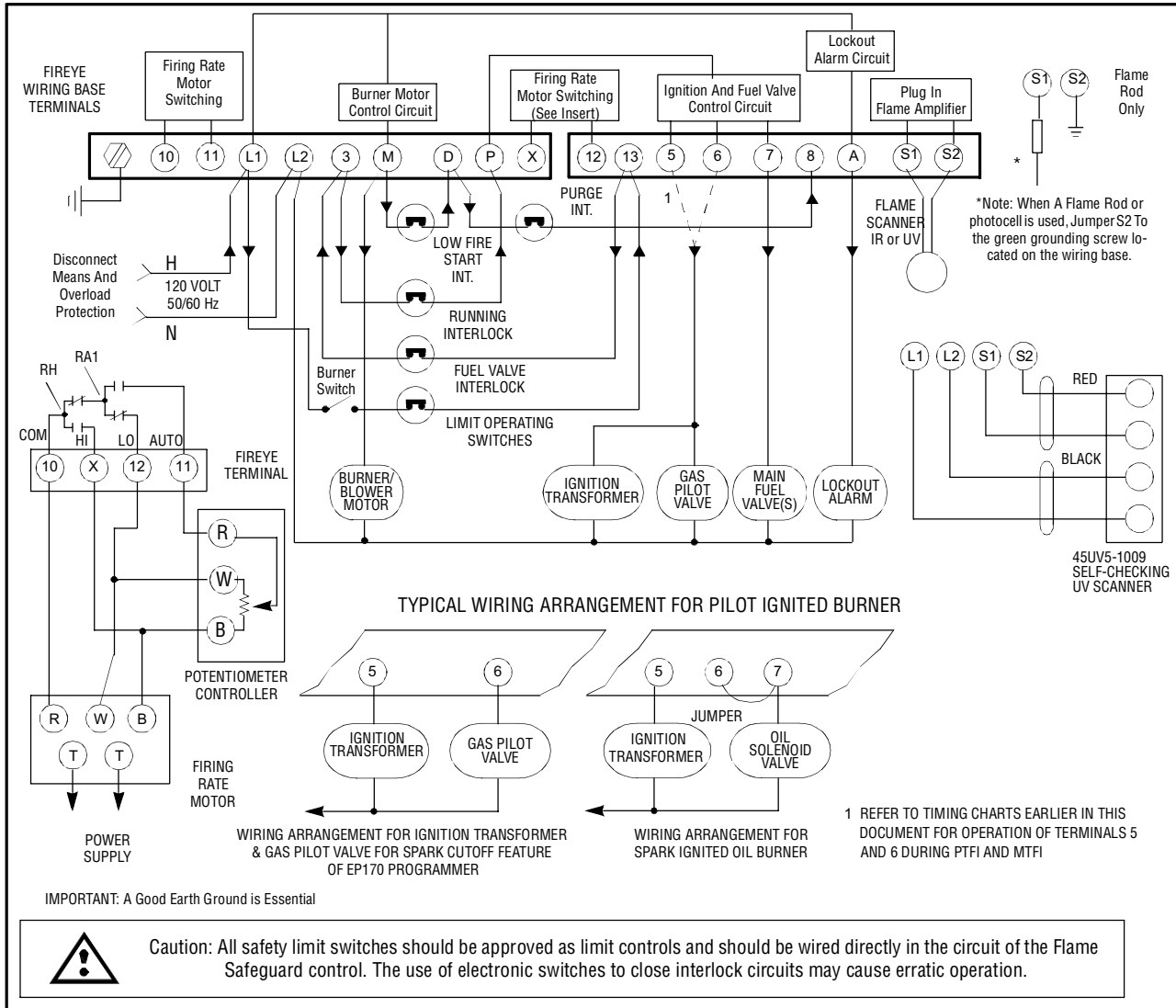

AUXILIARY DEVICE IN M-D-8 CIRCUIT AT FLAME MONITOR CONTROL

The function of the low fire start and interlock circuit internally in a Fireye Flame-Monitor unit is accomplished by highly reliable solid state electronic circuitry. This prohibits the connection of power consuming devices (i.e. lamps, annunciators, relays, timers, etc.) to the D or 8 terminals.

FLAME-MONITOR ELECTRICAL NOISE

In applications with excessive electrical noise, it may be helpful to add an electrical noise suppressor to the power supply of the control circuit. See Bulletin E-1101 or SN-100.

We recommend Fireye P/N 60-2333 on older EB700 chassis with Engineering Code lower than 3.



Wiring E100/E110 FLAME-MONITOR to a 4-20mA Firing Rate Damper Motor

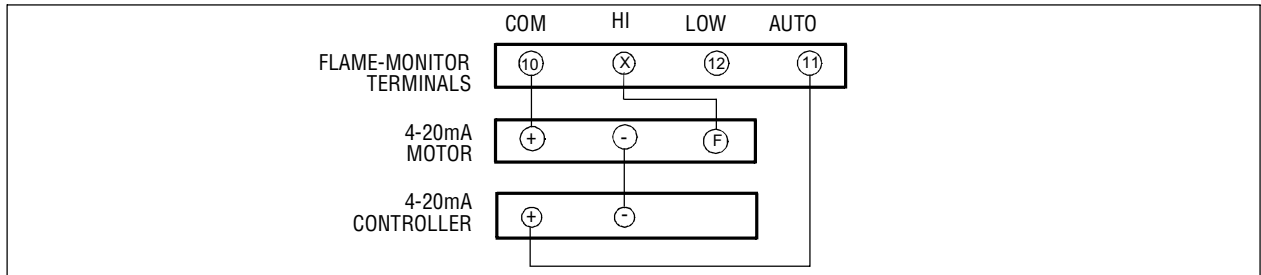



NOTICE

When Fireeye products are combined with equipment manufactured by others and/or integrated into systems designed or manufactured by others, the Fireeye warranty, as stated in its General Terms and Conditions of Sale, pertains only to the Fireeye products and not to any other equipment or to the combined system or its overall performance.

WARRANTIES

FIREYE guarantees for *one year from the date of installation or 18 months from date of manufacture* of its products to replace, or, at its option, to repair any product or part thereof (except lamps, electronic tubes and photocells) which is found defective in material or workmanship or which otherwise fails to conform to the description of the product on the face of its sales order. **THE FOREGOING IS IN LIEU OF ALL OTHER WARRANTIES AND FIREYE MAKES NO WARRANTY OF MERCHANTABILITY OR ANY OTHER WARRANTY, EXPRESS OR IMPLIED.** Except as specifically stated in these general terms and conditions of sale, remedies with respect to any product or part number manufactured or sold by Fireeye shall be limited exclusively to the right to replacement or repair as above provided. In no event shall Fireeye be liable for consequential or special damages of any nature that may arise in connection with such product or part.



FIREYE®
3 Manchester Road
Derry, New Hampshire 03038 USA
www.fireeye.com

EP-1601
OCTOBER 31, 2005
Supersedes Jan. 2004

