



— MODEL — **CRL**

# Pressure Relief Control

**DESCRIPTION**

The CRL Pressure Relief Control is a direct acting, spring loaded, diaphragm type relief valve. It may be used as a self-contained valve or as a pilot control for a Cla-Val Main valve. It opens and closes within very close pressure limits.

**INSTALLATION**

The CRL Pressure Relief Control may be installed in any position. The control body (7) has one inlet and one outlet port with a side pipe plug (24) at each port. These plugs are used for control connections or gauge applications. The inlet in the power unit body (6) is the sensing line port. A flow arrow is marked on the body casting.

**OPERATION**

The CRL Pressure Relief Control is normally held closed by the force of the compression spring above the diaphragm; control pressure is applied under the diaphragm.

When the controlling pressure exceeds the spring setting, the disc is lifted off its seat, permitting flow through the control.

When controlling pressure drops below spring setting, the spring returns the control to its normally closed position.

**ADJUSTMENT PROCEDURE**

The CRL Pressure Relief Control can be adjusted to provide a relief setting at any point within the range found on the nameplate.

Pressure adjustment is made by turning the adjustment screw (9) to vary the spring pressure on the diaphragm. Turning the adjustment screw clockwise increases the pressure required to open the valve. Counterclockwise decreases the pressure required to open the valve.

When pressure adjustments are complete the jam nut (10) should be tightened and the protective cap (1) replaced. If there is a problem of tampering, lock wire holes have been provided in cap and cover. Wire the cap to cover and secure with lead seal.

**DISASSEMBLY**

The CRL Pressure Relief Control does not need to be removed from the line for disassembly. Make sure that pressure shut down is accompanied prior to disassembly. If the CRL is removed from the line for disassembly be sure to use a soft jawed vise to hold body during work.

Refer to Parts List Drawing for Item Numbers.

1. Remove cap (1), loosen jam nut (10) and turn adjusting screw counterclockwise until spring tension is relieved.
2. Remove the eight screws (4) holding the cover (3) and powerunit body (6). Hold the cover and powerunit together and place on a suitable work surface.  
See NOTE under REASSEMBLY.
3. Remove the cover (3) from powerunit body (6). The spring (12) and two spring guides (11).
4. Remove nut (13) from stem (19) and slide off the Belleville washer (14), the upper diaphragm washer (15) and the diaphragm (16).
5. Pull the stem (19) with the disc retainer assembly (21) through the bottom of powerunit. The lower diaphragm washer (17) will slide off of stem top.
6. Remove jam nut (23) and disc retainer assembly (21) from stem. Use soft jawed pliers or vise to hold stem. The polished surface of stem must not be scored or scratched.
7. The seat (22) need not be removed unless it is damaged. If removal is necessary use proper size socket wrench and turn counterclockwise.  
Note: Some models have an integral seat in the body (7).

**INSPECTION**

Inspect all parts for damage, or evidence of cross threading. Check diaphragm and disc retainer assembly for tears, abrasions or other damage. Check all metal parts for damage, corrosion or excessive wear.

**REPAIR AND REPLACEMENT**

Minor nicks and scratches may be polished out using 400 grit wet or dry sandpaper fine emery or crocus cloth. Replace all O-rings and any damaged parts.

When ordering replacement parts, be sure to specify parts list item number and all nameplate data.

**REASSEMBLY**

In general, reassembly is the reverse of disassembly. However, the following steps should be observed:

1. Lubricate the O-Ring (18) with a small amount of a good grade of waterproof grease, (Dow Corning 44 medium grade or equal). Use grease sparingly and install O-ring in powerunit body (6).
2. Install stem (19) in powerunit body (6). Use a rotating motion with minimum pressure to let stem pass through O-ring.  
Do Not Cut O-Ring.
3. Install O-ring (5) at top of stem (19). Place lower diaphragm washer (17) on the stem with the serrated side up. Position diaphragm (16), upper diaphragm washer (15), with serration down, and Belleville washer (14) with concave side down.
4. Position powerunit body (6) as shown on parts list drawing (top view).
5. Continue reassembly as outlined in disassembly steps 1 through 3.

**Note:** Item (4) Screw will have a quantity of 8 for the 0-75 and 20-200psi design and a quantity of 4 for the 100-300psi design. Item (25) Screw is used on the 100-300psi design only. Install item (25), before item (4) for preload of item (12) spring.

SYMPTOM	PROBABLE CAUSE	REMEDY
Fails to open.	Controlling pressure too low.	Back off adjusting screw until valve opens.
Fails to open with spring compression removed.	Mechanical obstruction, corrosion, scale build-up on stem.	Disassemble, locate, and remove obstruction, scale.
Leakage from cover vent hole when controlling pressure is applied.	Diaphragm Damage	Disassembly replace damaged diaphragm.
	Loose diaphragm assembly.	Tighten upper diaphragm washer.
Fails to close.	No spring compression.	Re-set pressure adjustment.
Fails to close with spring compressed.	Mechanical obstruction.	Disassemble, locate and remove obstruction.



**CRL**

**1/2" & 3/4" PRESSURE RELIEF CONTROL**

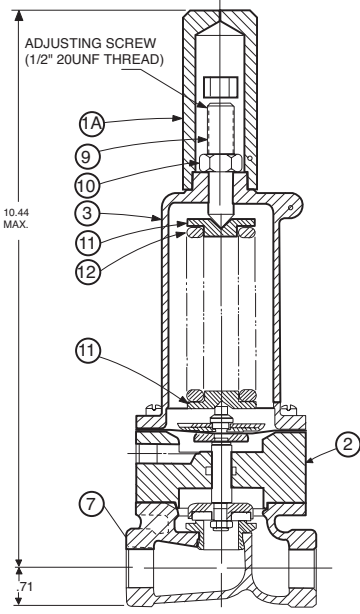
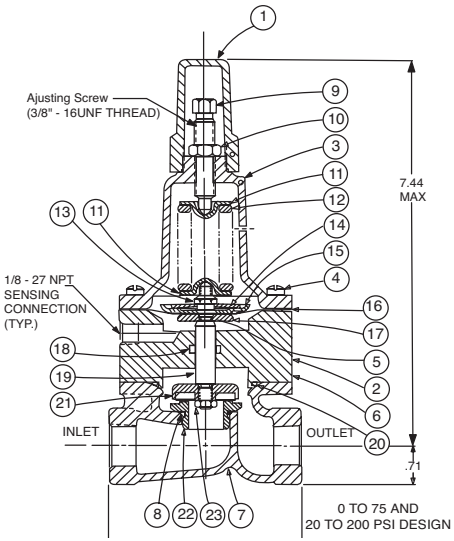
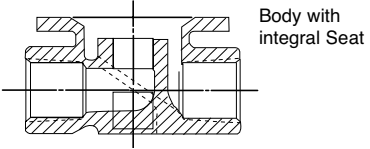
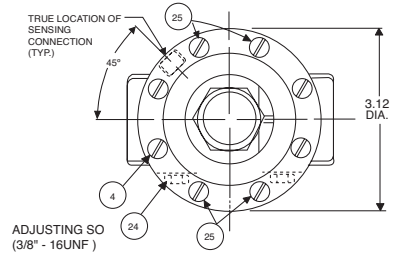

SIZE	SPRING RANGE	PART NUMBER
1/2"	0-75 PSI	79222-01E
1/2"	20-200 PSI	79222-02C
1/2"	100-300 PSI	82809-01D
3/4"	0-75 PSI	79229-01K
3/4"	20-200 PSI	79229-02H
3/4"	100-300 PSI	86005-01E

For 100-450 PSI Contact Factory

CRL RANGE PSI	APPROX. INCREASE FOR EACH CLOCKWISE TURN OF ADJUSTING SCREW
0 to 75	8.5 PSI
20 to 200	28.0 PSI
100 to 300	18.0 PSI

**When ordering parts please specify:**  
 1. All Nameplate Data  
 2. Item Part Number  
 3. Item Description

Item	Description	Material	Part Number		
			0-75	20-200	100-300
1	Cap	Plastic	67628J	67628J	1257601D
1A	Cap 100 to 300 psi Design	Plastic	1257601D	1257601D	1257601D
2	Nameplate	Brass	--	--	--
3	Cover	Bronze	C2544K	C2544K	44587E
4*	Screw Fil.Hd.10-32 x 1.88	303 SS	6757867E	6757867E	6757867E
5*	O-Ring	Rubber	00902H	00902H	00902H
6	Body, Powerunit	Bronze	7920504D	7920504D	7920504D
7	1/2" Body	Bronze	C7928K	C7928K	C7928K
	3/4" Body	Bronze	C9083B	C9083B	C9083B
8*	O-Ring, Seat	Rubber	00718H	00718H	00718H
9	Screw, Adjusting	Brass	7188201D	7188201D	7188201D
10	Nut Hex (Locking)	303 SS	6780106J	6780106J	6780106J
11	Guide, Spring	303 SS	71881H	71881H	1630301J
12	Spring,	CHR/VAN	71881H	71881H	1630201A
13	Nut, Stem, Upper	Bronze	73034B	73034B	73034B
14	Washer, Belleville	Steel	7055007E	7055007E	7055007E
15	Washer, Diaphragm (upper)	303 SS	71891G	71891G	71891G
16*	Diaphragm	Rubber	C1505B	C1505B	C1505B
17	Washer, Diaphragm (lower)	303 SS	45871B	45871B	45871B
18*	O-Ring, Stem	Rubber	00746J	00746J	00746J
19	Stem	303 SS	8982401F	8982401F	8982401F
20*	O-Ring, Body	Rubber	00767E	00767E	00767E
21*	Retainer Assembly, Disc	303 SS	C8964D	C8964D	C8964D
22	Seat	303 SS	62187A	62187A	62187A
23	Nut, hex, Stem, Lower	Bronze	6779806G	6779806G	6779806G
24	Pipe Plug	Bronze	6784701C	6784701C	6784701C
25*	Screw Fil.Hd, 10-32 x 2.25 (Qty 4 on 100-300 psi)	303 SS	6757867E	6757867E	6757867E
<b>FACTORY SET POINT</b>			<b>50 PSI</b>	<b>60 PSI</b>	<b>100 PSI</b>
<b>REPAIR KIT*</b>			9170007A	9170007A	9170007A