



# Pressure Reducing Control Valves

- Direct Acting
- Hydraulic or Pneumatic Operation
- Simplified Design, Easy Adjustments
- Operates in Any Position



**CRD40**

Available Sizes 1/2" & 3/4"

The Cla-Val Model CRD40 Pressure Reducing Control automatically reduce a higher inlet pressure to a lower outlet pressure. This direct-acting, spring-loaded, diaphragm-type control can operate hydraulically or pneumatically. These valves are held open by the force of the compression spring above the diaphragm, and close when the downstream pressure acting on the underside of the diaphragm exceeds the spring setting. The CRD40 senses downstream pressure directly. Flow through the control responds to changes in downstream pressure. Turning the adjusting screw clockwise increases the delivery pressure, and turning it counterclockwise decreases the pressure. A resilient disc assures tight shut-off on dead-end service.

These valves are ideal small capacity regulators for applications such as water coolers, fountains, humidifiers, gas refrigerators, and air supply to tools and instruments. They also have numerous applications as pilot controls on many Cla-Val Automatic Control Valves.

## Specifications

**Size** 1/2" & 3/4" NPT Threaded

**Temperature Range** Water: to 180°F Max.

### Materials

Main Valve Body	Cast Bronze ASTM B-584
Bell Housing	UV resistant polymer composite
Internals	Stainless Steel
Stem	Brass ASTM B16
Elastomers	EPDM (FDA approved) Buna Nitrile (FDA approved)
Cartridge	Delrin (NSF Listed)
Springs	Hard Drawn wire, ASTM A 227

**Adjustment Range:** 15 to 150 psi

**Pressure Rating:** 400 psi

### Dimensions (In Inches)

SIZE		CONNECTIONS	DIMENSIONS (approximate)								WEIGHT	
			A		B		C		D			
in	mm		in	mm	in	mm	in	mm	in	mm	lbs.	kg.
1/2	15	FNPT	3 1/2	89	6 1/4	159	1 1/8	29	2 1/2	64	3	1.5
3/4	20	FNPT	3 1/2	89	6 1/4	159	1 1/8	29	2 1/2	64	3	1.5

## When Ordering, Please Specify

1. Catalog No. CRD40
2. Size

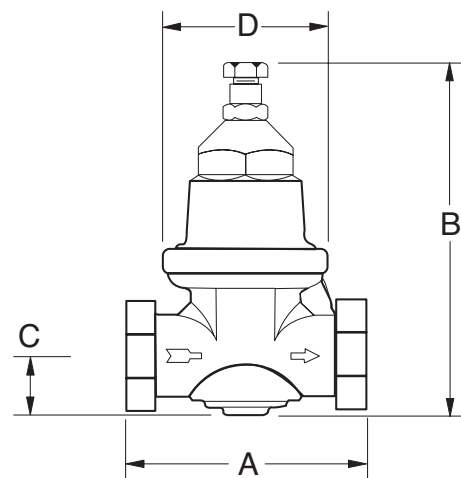

Distributed By: M&M Control Service, INC.

Phone: 800-876-0036

Fax: 847-356-0747

Email: Sales@mmcontrol.com