

Balanced Direct Acting Pressure Reducing Valve



- **Balanced, Single Seat Design**
- **Operates in Any Position**
- **Easy Installation**
- **Stainless Steel Trim Standard**
- **Gauge Connections Standard**
- **All Bronze Body and Cover**

The Cla-Val Model 990 Pressure Reducing Valve automatically reduces a higher inlet pressure to a steady lower downstream pressure with our unique balanced design. This valve is an accurate regulator capable of holding downstream pressure to a predetermined amount, regardless of upstream pressure fluctuations.

Periodic maintenance consist of regular cleaning of internal strainer that is accessed by removing bottom plug. There are no user serviceable components.

Typical Applications

High rise buildings use 990 Pressure Reducing Valves in various water systems (potable water, boiler feed air conditioning, etc.) to control pressure fluctuations between floors.

Industrial plants use 990 Pressure Reducing Valves between a high pressure supply system and equipment requiring lower pressure. Typically 990 Pressure Reducing Valves are used at supply connections for water heaters, boiler feed water or other process water systems.

Municipal water systems use 990 Pressure Reducing Valves at service connections in a high pressure distribution zone.

Depending on flow requirements, 990's may be installed in parallel. One 990 provides desired outlet pressure while the second 990 handles low flow conditions. If necessary, additional 990s can be added for more flow capacity. The 990 is also ideal for a low flow bypass around a larger Cla-Val 90 Series Pressure Reducing Valve.

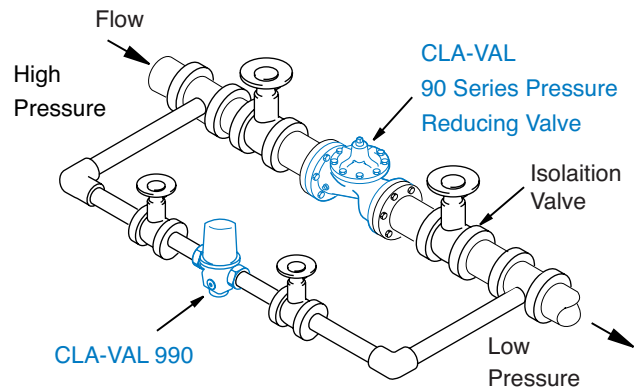
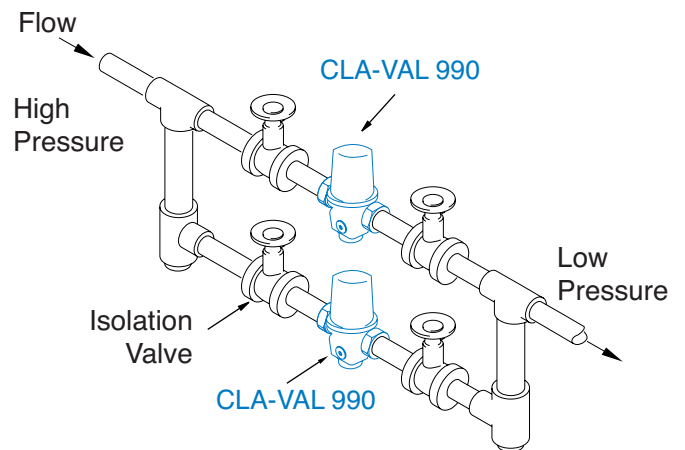

Valve Operation

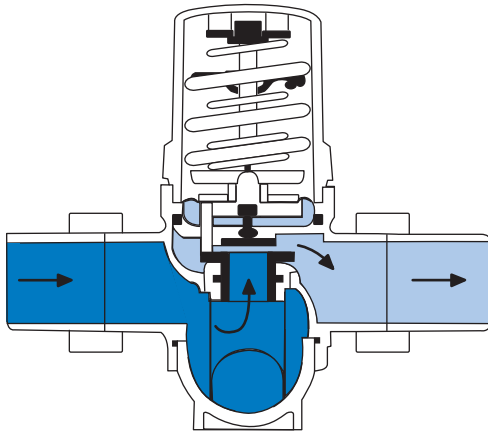

Flow Condition

When flow begins, the pressure on the underside of the diaphragm will lower below the set-point of the spring causing the diaphragm to move the valve seat away from the valve seal allowing flow to occur. As the flow increases downstream, the pressure spring pushes the diaphragm and the valve seat away from the valve seal to regulate outlet pressure to desired value.

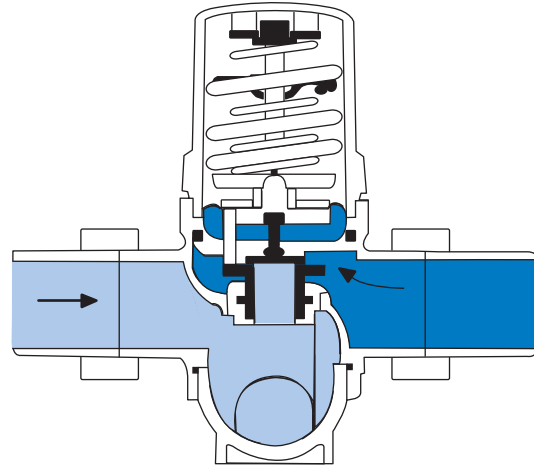

No Flow Condition

When there is no flow, the downstream pressure increases and acts against the under side of the diaphragm, pulling the valve seat up against the valve seal to close the valve.

Reduced Pressure Falloff

Unlike pilot controlled pressure reducing valves, direct acting valves are subject to "reduced pressure falloff" (RPF). Reduced pressure falloff is the decrease in downstream regulated pressure that occurs when the flow increases. When the demand for flow increases, the valve must open wider and wider to permit the flow. The only way the valve can open is for the spring force to be greater than the hydraulic force under the diaphragm (the force trying to close the valve). The downstream pressure therefore, must "fall off" or decrease before the spring can open the valve. All spring actuated direct acting valves have similar operating characteristics.

Noise and Velocity Guidelines

Noise in water piping systems can sometimes be attributed to high velocities of water through the valve seat. In general, as the water velocity increases, the noise produced by the installation will increase.

Where noise levels are important, such as residences, hospitals, or schools, pipeline velocities should be in the range of 5 to 10 fps. The chart below shows velocity and the corresponding reduced pressure falloff. If these values for falloff are not exceeded, the 990 will produce the least amount of noise.

Velocity Guide Chart

Velocity fps	Reduced Pressure Falloff (RPF) psi	
	½"-2"	2½"
5.0	6.0	8.5
7.5	9.5	12.0
10.0	12.5	17.0

Sizing

Step One

Determine the following from the application:

1. Inlet pressure and desired outlet pressure
2. Maximum and minimum flow rate
3. Allowable reduced pressure falloff or maximum velocity based on acceptable noise level

Step Two

Determine the pressure differential across the valve by subtracting the desired outlet pressure from the inlet pressure. If there will be any fluctuations in the inlet pressure, calculate both high and low differentials. At all times the differential must be at least 14.5 psi. When the differential is greater than 100 psi, use two valves in series.

Step Three

Determine the valve size by using the Valve Capacity Charts on the next page. Start by entering the appropriate chart at your system's maximum flow rate. Locate the value for the maximum allowable reduced pressure falloff for your application. Select the valve size with a RPF value that is less than the maximum RPF.

If demand flow fluctuate beyond the capacity of one valve, use two or more Model 990's in parallel. Size one valve to handle the low flow, and the other valve(s) to handle the higher flows. Set the low flow valve to approximately 3-4 psi higher than the other valve(s).

Valve Capacity Charts

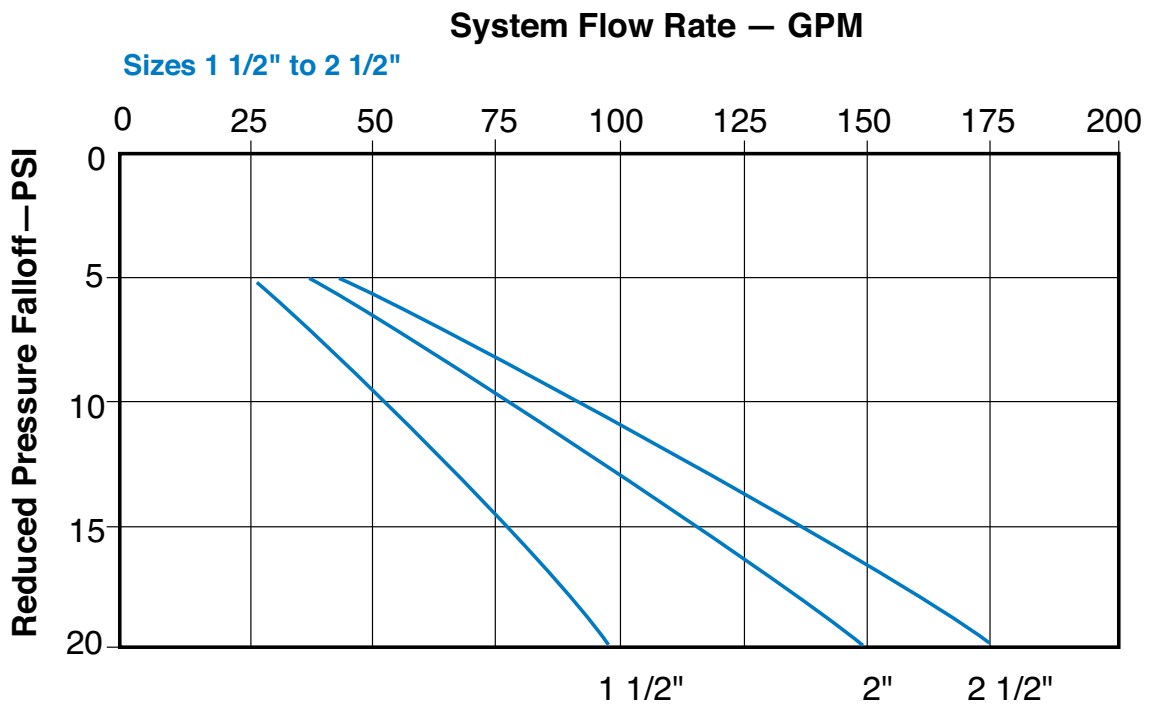
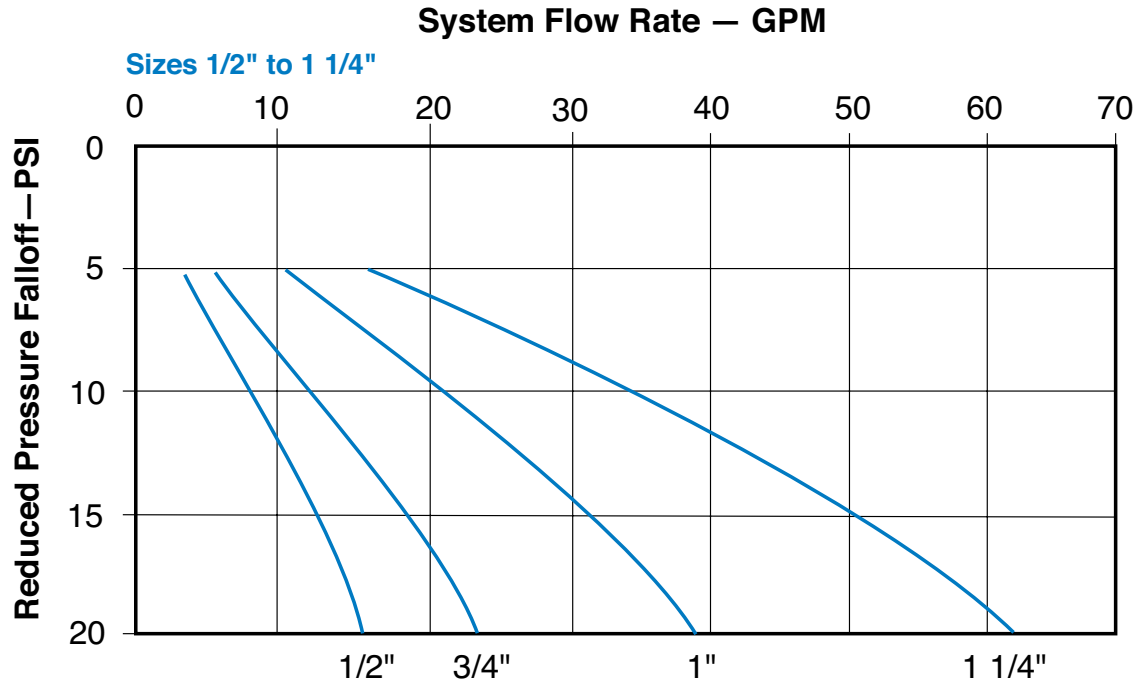

Valve Selection Example

Given the following:

Inlet Pressure: 120 psi
Desired Outlet Pressure: 50 psi
Maximum Flow: 60 gpm
Minimum Flow: 0 gpm
Maximum Velocity: 7.5 fps

From Velocity Guide Chart select falloff of 9.5 psi.
Using the Capacity Chart, find the intersection of 9.5 psi and 60 gpm which is above the 1 1/2" size. Choose the 2" size to keep the velocity below the desired maximum.

Specifications

Sizes

½", ¾", 1", 1¼", 1½", 2", 2½"

Temperature Range

Water: to 125°F Max

Diaphragm:

Reinforced Neoprene

End Details

Dual Union Tailpieces, NPT Threaded

Materials

Body and Cover:
Bronze ASTM B62

Disc: Buna-N® Rubber

Pressure Ratings

Maximum Inlet Pressure: 357 psi (25 Bar)
Maximum Outlet Pressure: 145 psi (10 Bar)
Minimum Differential Pressure: 14.5 psi

Strainer:
416 Stainless Steel

Adjustment Ranges

7 to 29 psi (0.5 - 2 Bar)
29 to 87 psi (2 - 6 Bar)

Factory Set Pressure

29psi (2 Bar)
56psi (4 Bar)
87psi (6 Bar)

Valve Trim:
416 Stainless Steel

Dimensions (In Inches)

Size	A	B	C	D	E	Weight Lbs.
½"	5.83	3.09	1.12	2.05	4.21	1.6
¾"	6.25	3.37	1.40	2.28	4.77	2.2
1"	7.25	4.33	2.03	2.76	6.36	4.0
1¼"	8.34	4.74	2.52	3.03	7.26	5.8
1½"	9.50	6.18	3.15	3.68	9.33	9.8
2"	11.38	6.77	3.86	4.06	10.63	15.1
2½"	12.20	6.77	3.86	4.06	10.63	17.8

Adjustment tools

To adjust pressure setting use following Allen wrenches.
One full turn is approximately 5 psi (0.35 bar) change.

Size	Allen wrench size
½" - ¾"	5 mm
1" - 1¼"	6 mm
1½", 2", 2½"	8 mm

NOTE: Remove top cover plug with 6mm Allen wrench

Gauge connections

½" - ¾" has ½" Rp Parallel thread

1" - 2½" has ¼" Rp Parallel thread

Use 4mm Allen to remove plug.

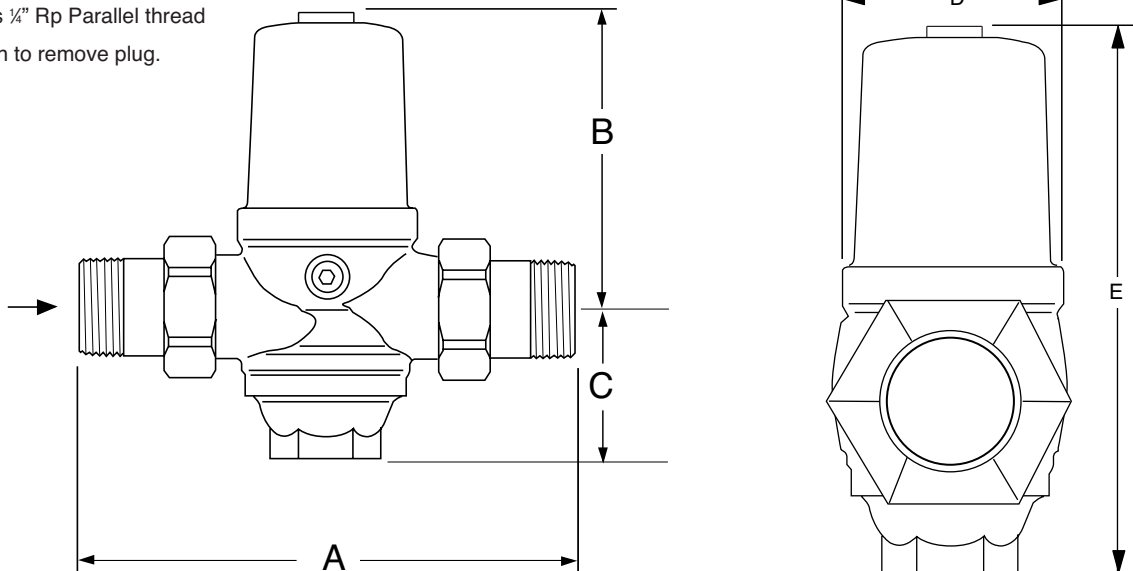

When Ordering, Please Specify

1. Catalog No. 990

2. Size

3. Adjustment Range



Distributed By:
M&M Control Service, INC.
Phone: 800-876-0036
Fax: 847-356-0747
Email: Sales@mmcontrol.com