



— MODEL — 790-01

Pressure Reducing Valve



Description

The Cla-Val Model 790-01 is a hydraulically operated, pilot actuated automatic control valve for pressure reducing service. The main valve consists of only two parts: a stainless steel body, and an elastomeric liner or control element.

Pressure reducing valves are used to lower pipeline pressure to a predetermined set point. Cla-Val Model 790-01 automatically controls downstream pressure, from no flow to full open flow, without regard to changes in inlet pressure. Outlet pressure control is smooth and precise since the friction and hysteresis of the valve and pilot is negligible.

Because the valve will not chatter or slam under low flow conditions, it is not necessary to parallel Cla-Val Model 790-01 with a second smaller size control valve to obtain accurate pressure control at low flow rates. In any size, Cla-Val Model 790-01 will control pressure right down to shutoff.

Pressure reducing valves can be supplied as a combination with check valve. Control systems are fully piped at the factory and the Cla-Val Model 790-01 is shipped ready for installation.

Performance Specification

Capacity:	See Technical Data Sheet
C _f Factor:	0.9
Cavitation:	See Technical Data Sheet
Rangeability:	500:1
Bearing Friction:	No friction from slip-type bearings

Design Specification

Sizes:	2, 3, and 6 inch wafer style 6, 8, 10, and 12 inch flanged 6, 8, 10, 12 inch Victaulic® Ends
End Detail Wafer:	Fits ANSI B16.5 class 125, 150, 250, and 300 flanges
End Detail Flanged:	ANSI B16.5 class 150 (fits class 125) or ANSI B16.5 class 300 (fits class 250)
End Detail Victaulic®:	Fits standard steel pipe
Operating Pressure:	720 psi maximum Victaulic® Ends - 300 psi max.
Maximum Differential:	225 psid For higher differential consult factory
Reverse Pressure:	125 psid maximum
Approvals:	PUB Listed.....Sizes 2" thru 6"
Temperature Range:	32 to 160 degrees F*
Flange Operating Pressure:	Class 125-175 psi maximum Class 150-275 psi maximum Class 250-300 psi maximum Class 300-720 psi maximum
Victaulic® Ends Rating:	300 psi maximum

*Standard natural rubber 65 durometer in water service.
Temperature range depends on liner material. Higher differential pressure ratings available.

For other than standard ANSI flanges consult factory
Din drilling available on all sizes

Purchase Specification

Valve and control system shall lower line pressure to a predetermined set point and shall maintain that set point regardless of variations in flow or inlet pressure. Control valve shall be constructed of two parts: a stainless steel body, and an elastomeric liner or control element. Minimum rangeability shall be 500:1 based on capacity at flowing pressure conditions. C_f shall be greater than or equal to 0.9. Valve and control system shall be similar in all respects to Cla-Val Model 790-01 as manufactured by Cla-Val, Newport Beach, California.

Material Specification

Body:	316L Stainless Steel
Liner:	Natural Rubber, 65 durometer (standard) Viton, EPDM, Nitrile, Silicone (available)
Liner Retainer:	316 Stainless Steel

Pilot

Body:	ASTM B62 Bronze*
Spring Cover:	ASTM B62 Bronze*
Wetted Parts:	Bronze/Stainless Steel*, Buna-N®

Accessories

Shut-off Cock:	Brass*
"Y" Strainer:	Bronze*
Speed Controls:	Brass*
Check Controls:	Brass*
Control Piping:	Copper*
Control Fittings:	Brass*

*316 stainless steel available



790-01 Basic Components

Item	Description
1	100-42 Roll Seal Main Valve
2	X58C Restriction Fitting
3	CRD Pressure Reducing Control
4	X43 "Y" Strainer

Optional Features

Item	Description
B	CK2 Cock (Isolation Valve)
C	CV Flow Control (Closing)*
D	Check Valves (125 psid max. reverse pressure)
S	CV Flow Control (Opening)*

* The opening & closing speed controls (optional) on this valve should always be open at least 3 turns off their seats.

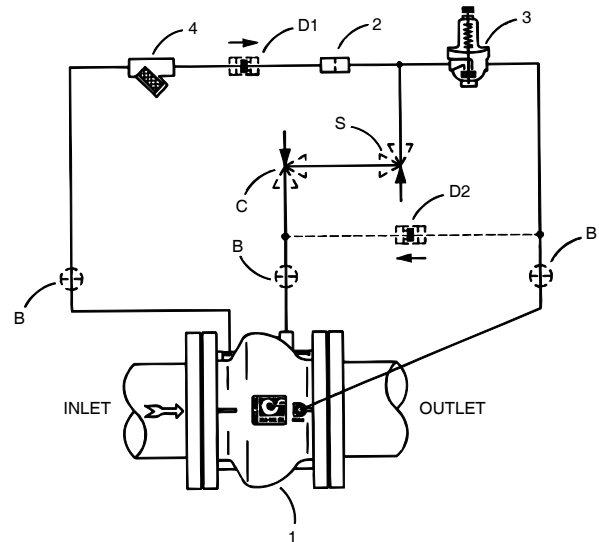

Dimensions (100-42 Main Valve)

Valve Size (Inches)	2	3	4	6	8	10	12
A	2 7/8	3 9/16	4 1/8	5 1/4	—	—	—
B	—	—	—	10 7/8	14 3/8	18	21 5/8
BB	4 3/8	5 7/8	7 3/8	9 13/16	—	—	—
C	—	—	—	9	11	13	15 1/4
CC	2 1/2	3 1/4	4	8	—	—	—
D (ANSI 150)	—	—	—	11	13 1/2	16	19
D (ANSI 300)	—	—	—	12 1/2	15	17 1/2	20 1/2
E (Ports)	—	—	—	3/8	3/8	1/2	1/2
Approx. Wt. (150 lbs.)	4	7 1/2	14	58	115	190	290
Approx. Wt. (300 lbs.)	4	7 1/2	14	87	155	250	375

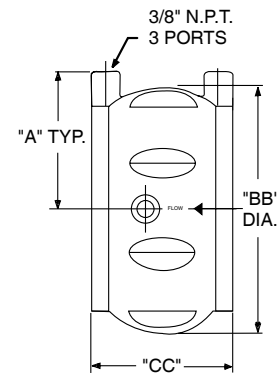

2", 3", 4" and 6" Wafer Style

VALVE SIZE (mm)	50	80	100	150	200	250	300
A	73	90	105	133	-	-	-
B	-	-	-	276	365	457	549
BB	111	149	187	249	-	-	-
C	-	-	-	229	279	330	387
CC	64	83	102	202	-	-	-
D (ANSI 150)	-	-	-	279	343	406	483
D (ANSI 300)	-	-	-	318	381	445	521
E (Ports) -	-	-	10	10	13	13	-
Approx. kg. (150lbs.)	1.81	3.63	6.35	30	54.43	89	151.50
Approx. kg. (150lbs.)with Studs & Nuts	2.72	4.54	10	-	-	-	-
Approx. kg. (300lbs.)	1.81	3.63	6.35	41.73	72.57	116.57	191
Approx. kg. (300lbs.)with Studs & Nuts	5	6.35	11.80	-	-	-	-

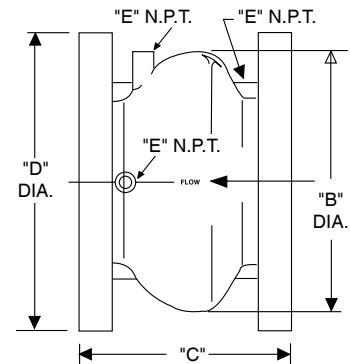

6", 8", 10" and 12" Flanged Style

When Ordering Please Specify:

1. Catalog No. 790-01
2. Valve Size
3. Fluid Being Handled
4. Fluid Temperature Range
5. Inlet Pressure Range
6. Outlet Pressure Range
7. Maximum Differential Pressure
8. Minimum Differential Pressure
9. Maximum Flow Rate
10. Pilot Set Point



Distributed By:
M&M Control Service, INC.
Phone: 800-876-0036
Fax: 847-356-0747
Email: Sales@mmcontrol.com