



CDS6

Altitude Pilot Control

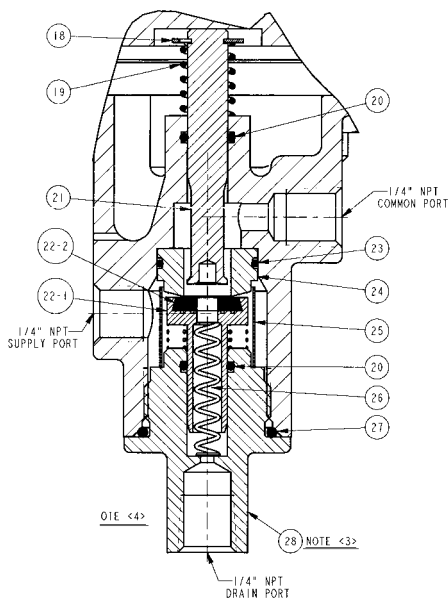
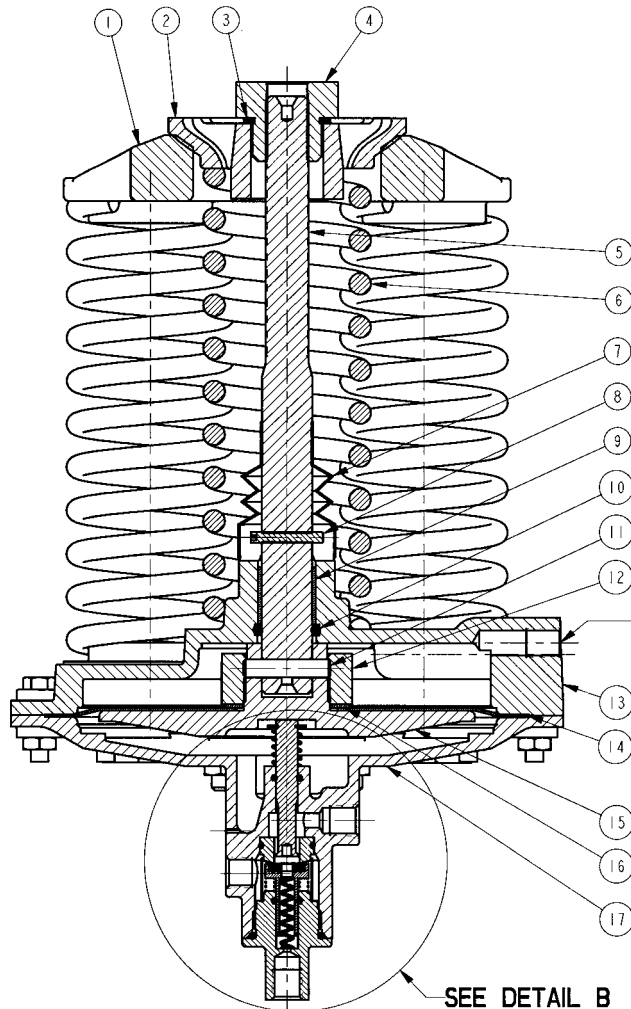

TABLE 1

RETAINER PART NO.	NUMBER OF SPRINGS	NUMBER OF WASHERS (ITEM 31)
----	1	0
29332-01C	2 OR 3	2
29331-01E	4 OR 5	4

TABLE 2

(SPRING ADJUSTMENT
1 TURN = 0.0625"

CDS-6 STOCK No. 2" SIZE	CDS-6 STOCK No. 2-1/2 & LARGER	ALTITUDE RANGE FT H ₂ O	No. of SPRINGS	PSI Change PER TURN	ALTITUDE CHANGE PER TURN
29330-06F	29330-01E	5 To 40 Ft.	1	0.32	0.75
29330-07H	29330-02G	30 To 80 Ft.	2	0.64	1.50
29330-08K	29330-03J	70 To 120 Ft.	3	0.96	2.50
29330-09B	29330-04A	110 To 160 Ft.	4	1.28	3.00
29330-10D.	29330-05D	150 To 200 Ft.	5	1.60	3.70

When ordering parts specify:

All Nameplate Data, Part Description and Part Number

ITEM	DESCRIPTION	QTY.	PART #	LIST PRICE
* 1	Retainer, Sprint (see table 1)	---		
2	Retainer Spring, Swivel	1		
3	Washer, Thrust	1		
4	Nut, Adjusting	1		
5	Stem, Upper	1		
6	Spring (see table 1)	---		
* 7	Bellows	1		
* 8	Set Screw	1		
9	Bushing, Stem	1		
* 10	O-Ring	1		
11	Pin, Stem Retaining	1		
12	Nut, Diaphragm Washer	1		
13	Cover, Upper	1		
* 14	Diaphragm	1		
15	Diaphragm Washer	1		
16	Washer, Diaphragm Nut	1		
17	Cover, Lower	1		
* 18	Retaining Ring	1		
* 19	Spring, Lower Stem	1		
* 20	O-Ring	2		
21	Stem, Lower	1		
* 22	Poppet Assembly	1		
22-1	Poppet	1		
22-2	Disc	1		
* 23	O-Ring	1		
24	Seat	1		
25	Strainer	1		
26	Spring, Poppet	1		
* 27	O-Ring	1		
* 28	Guide, Poppet	1		
29	Bracket, Mounting	1		
30	Bolt HX. HD. 5/16-18 x 1.25	10		
31	Washer (see table 1)	---		
32	Bolt HX. HD. 5/16-18 x 2.0	2		
33	Nut, 5/16-18	12		

* Recommended Spare Parts

Distributed By: M&M Control Service, INC.
Phone: 800-876-0036 Fax: 847-356-0747

Email: Sales@mmcontrol.com