

Modulating Float Valve



- **Accurate Level Control**
- **Completely Automatic Operation**
- **Simple Operation**
- **Drip-Tight Shut-Off**
- **Easy Installation and Maintenance**

The Cla-Val Model 428-01/628-01 Float Valve modulates to maintain a constant liquid level in a storage tank by compensating for variations in supply or demand. It can be installed to control the flow into or out of the tank by either closing on a rising level or opening on a rising level. This valve is a hydraulically operated, pilot controlled diaphragm valve.

The pilot control system consists of an integral variable orifice in the main valve cover and a remotely mounted float control. A slight change in liquid level moves the float control. This action varies the pressure in the valve cover, causing the main valve to seek a new position. The integral variable orifice automatically regulates the flow into the cover chamber until the valve reaches a position that is in direct relation to the position of the float control.

Schematic Diagram

Item	Description
1	Hytrol Main Valve
2	CFM-9 Float Control
3	CK2 (Isolation Valve)

Optional Features

Item	Description
A	X46A Flow Clean Strainer
D	Check Valves with Isolation Valve
F	Independent Operating Pressure
Y	X43 "Y" Strainer

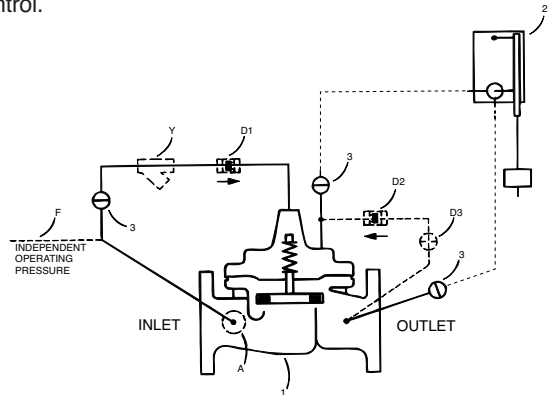

Installation Data

The valve may be installed in any position. The remote float control may be mounted at any convenient location above the liquid level. Float rods are available in lengths from 2' to 12' in one-foot increments.

A stilling well (8" min. diameter) should be provided around the float if the liquid surface is subject to turbulence, ripples or wind.

The float control may be installed at any elevation above the valve providing that the amount of flowing line pressure in psi is equal to or greater than the vertical distance in feet between the valve and the float control.

When a separate source of supply pressure (Option F) is used by the pilot control system, that pressure must at all times be constant and equal to or greater than the pressure at the valve inlet.

DO NOT USE FOR ON-OFF SERVICE.

Note: We recommend protecting tubing and valve from freezing temperatures.

Typical Applications

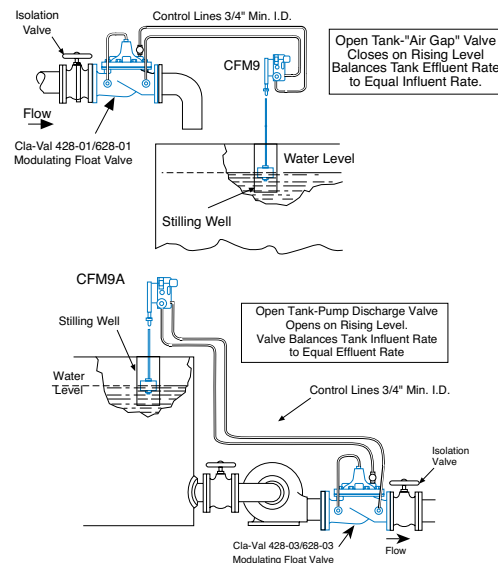

Model 428-01 (Uses Basic Valve Model 100-01)

Pressure Ratings (Recommended Maximum Pressure - psi)

Valve Body & Cover		Pressure Class			
		Flanged		Threaded	
Grade	Material	ANSI Standards*	150 lb.	300 lb.	End** Details
ASTM A536	Ductile Iron	B16.42	250	400	400
ASTM A216-WCB	Cast Steel	B16.5	285	400	400
ASTM B62	Bronze	B16.24	225	400	400

Note: * ANSI standards are for flange dimensions only.
 Flanged valves are available faced but not drilled.
 ** End Details machined to ANSI B2.1 specifications.

Materials

Component	Standard Material Combinations		
Body & Cover	Ductile Iron	Cast Steel	Bronze
Available Sizes	1½" - 6"	1½" - 6"	1½" - 6"
Disc Retainer & Diaphragm Washer	Cast Iron	Cast Steel	Bronze
Trim: Disc Guide, Seat & Cover Bearing	Bronze is Standard Stainless Steel is Optional		
Disc	Buna-N® Rubber		
Diaphragm	Nylon Reinforced Buna-N® Rubber		
Stem, Nut & Spring	Stainless Steel		

For material options not listed, consult factory.
 Cla-Val manufactures valves in more than 50 different alloys.

Dimensions (In inches)

100-01 (Globe)

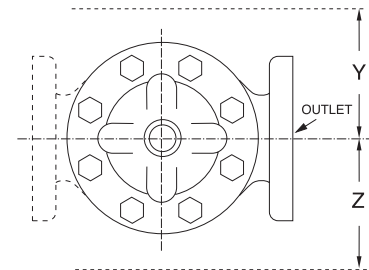
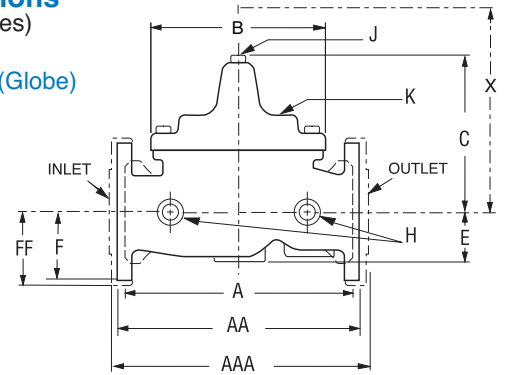

100-01 (Angle)

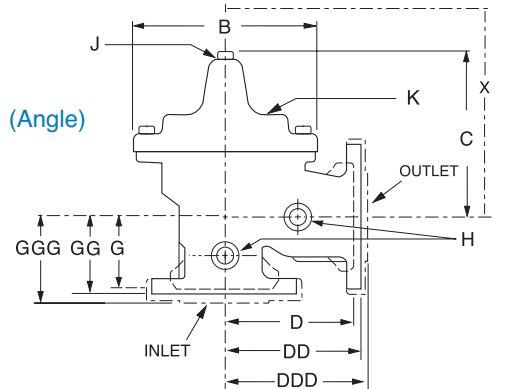

Model 428-01 Dimensions (In Inches)

Valve Size (Inches)	1¼-1½	2	2 ½	3	4	6
A Threaded	7.25	9.38	11.00	12.50	—	—
AA 150 ANSI	8.50*	9.38	11.00	12.00	15.00	20.00
AAA 300 ANSI	9.00*	10.00	11.62	13.25	15.62	21.00
B Dia.	5.62	6.62	8.00	9.12	11.50	15.75
C Max.	5.50	6.50	7.56	8.19	10.62	13.38
D Threaded	3.25	4.75	5.50	6.25	—	—
DD 150 ANSI	4.00*	4.75	5.50	6.00	7.50	10.00
DDD 300 ANSI	4.25*	5.00	5.88	6.38	7.88	10.50
E	1.12	1.50	1.69	2.56	3.19	4.31
F 150 ANSI	2.50	3.00	3.50	3.75	4.50	5.50
FF 300 ANSI	3.06	3.25	3.75	4.13	5.00	6.25
G Threaded	1.88	3.25	4.00	4.50	—	—
GG 150 ANSI	4.00*	3.25	4.00	4.00	5.00	6.00
GGG 300 ANSI	4.25*	3.50	4.31	4.38	5.31	6.50
H NPT Body Tapping	¾	¾	½	½	¾	¾
J NPT Cover Center Plug	¼	½	½	½	¾	¾
K NPT Cover Tapping	¾	¾	½	½	¾	¾
Valve Stem Internal Thread UNF	10-32	10-32	10-32	¼-28	¼-28	¾-24
Stem Travel	0.4	0.6	0.7	0.8	1.1	1.7
Approx. Ship Wt. Lbs.	15	35	50	70	140	285
X Pilot System	11.00	13.00	14.00	15.00	17.00	29.00
Y Pilot System	9.00	9.00	10.00	11.00	12.00	20.00
Z Pilot System	9.00	9.00	10.00	11.00	12.00	20.00

*1½" Size Only

Model 628-01 (Uses Basic Valve Model 100-20)

Dimensions
(In inches)

Pressure Ratings (Recommended Maximum Pressure - psi)

Valve Body & Cover		Pressure Class		
		Flanged		
Grade	Material	ANSI Standards*	150 lb.	300 lb.
ASTM A536	Ductile Iron	B16.42	250	400
ASTM A216-WCB	Cast Steel	B16.5	285	400
ASTM B62	Bronze	B16.24	225	400

Note: *ANSI standards are for flange dimensions only.
Flanged valves are available faced but not drilled.

100-20 (Globe)

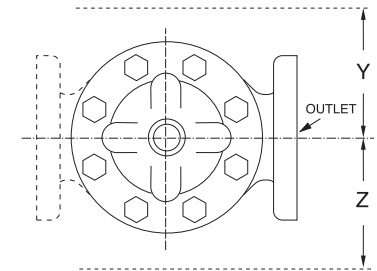
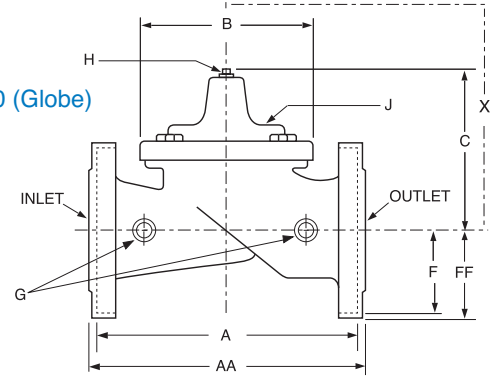

100-20 (Angle)

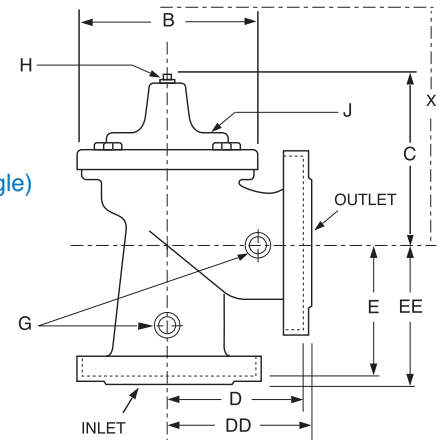

Materials

Component	Standard Material Combinations		
Body & Cover	Ductile Iron	Cast Steel	Bronze
Available Sizes	3" - 8"	3" - 8"	3" - 8"
Disc Retainer & Diaphragm Washer	Cast Iron	Cast Steel	Bronze
Trim: Disc Guide, Seat & Cover Bearing	Bronze is Standard Stainless Steel is Optional		
Disc	Buna-N® Rubber		
Diaphragm	Nylon Reinforced Buna-N® Rubber		
Stem, Nut & Spring	Stainless Steel		

For material options not listed, consult factory.
Cla-Val manufactures valves in more than 50 different alloys.

Model 628-01 Dimensions (In Inches)

Valve Size (Inches)	3	4	6	8
A 150 ANSI	10.25	13.88	17.75	21.38
AA 300 ANSI	11.00	14.50	18.62	22.38
B Dia.	6.62	9.12	11.50	15.75
C Max.	7.00	8.62	11.62	15.00
D 150 ANSI	—	6.94	8.88	10.69
DD 300 ANSI	—	7.25	9.38	11.19
E 150 ANSI	—	5.50	6.75	7.25
EE 300 ANSI	—	5.81	7.25	7.75
F 150 ANSI	3.75	4.50	5.50	6.75
FF 300 ANSI	4.12	5.00	6.25	7.50
H NPT Body Tapping	3/8	1/2	3/4	3/4
J NPT Cover Center Plug	1/2	1/2	3/4	3/4
K NPT Cover Tapping	3/8	1/2	3/4	3/4
Valve Stem Internal Thread UNF	10-32	1/4-28	1/4-28	1/4-24
Stem Travel	0.6	0.8	1.1	1.7
Approx. Ship Wt. Lbs.	45	85	195	330
X Pilot System	13.00	15.00	27.00	30.00
Y Pilot System	10.00	11.00	18.00	20.00
Z Pilot System	10.00	11.00	18.00	20.00

Valve Selection										
		Inches	1¼	1½	2	2½	3	4	6	8
		mm	32	40	50	65	80	100	150	200
		End Detail	Threaded	Threaded & Flanged			Flanged			
Model 428-01	Basic Valve 100-01	Globe								
		Angle								
	Suggested Flow (gpm)	Max. Continuous	93	125	210	300	460	800	1800	
		Max. Intermittent	120	160	260	370	580	990	2250	
	Suggested Flow (Liters/Sec)	Max. Continuous	6	8	13	19	29	50	113	
Max. Intermittent		7.6	10.1	16.4	23	37	62	142		
Model 628-01	Basic Valve 100-20	Globe								
		Angle								
	Suggested Flow (gpm)	Max. Continuous					260	580	1025	2300
		Max. Intermittent					16	37	65	145

628-01 is the reduced internal port size version of the 428-01.

For 100-32 basic valves, suggested flow calculations were based on flow through Schedule 40 Pipe. Maximum continuous flow is approx. 20 ft/sec (6.1 meters/sec) & maximum intermittent is approx. 25 ft/sec (7.6 meters/sec). For 100-33 basic valves, suggested flow calculations were based on flow through the valve seat. Approx. 26 ft/sec (7.9 meters/sec) is used for maximum continuous flow.

Important Notice: Do Not Oversize

Pilot System Specifications

Temperature Range
Water: to 180°F

Materials:

In contact with operating fluid: Bronze, Stainless Steel, Monel, with Buna-N® Rubber seals.
 Float linkage: Brass, PVC
 Base plate: Enameled Steel
 Float: Polypropylene
 Float Rod: Standard - Two 12" sections of PVC rod, with 12" extension increments at additional cost.
 Float Rod: Optional - 24" stainless steel rod, with 24" extension increments at additional cost.
 A larger counterweight is required if float rod length exceeds 4'. Consult factory for details.

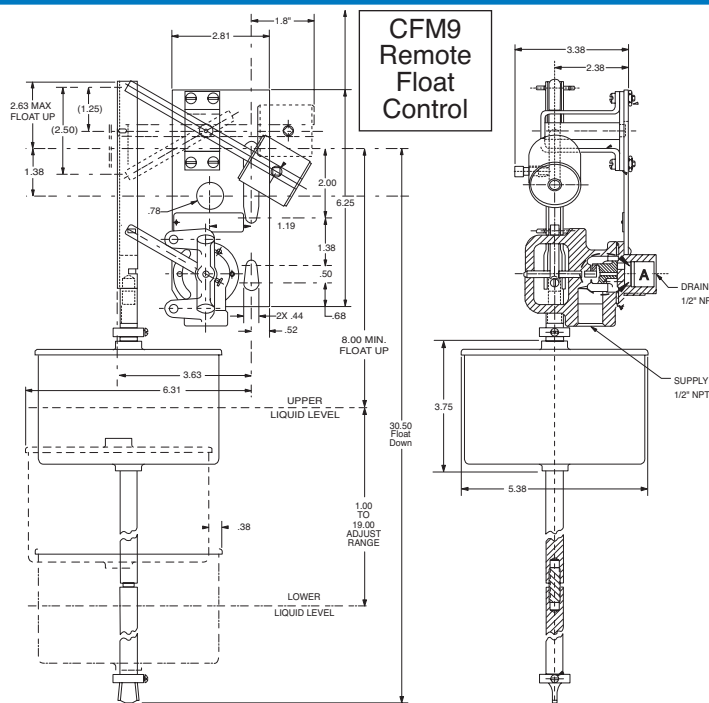

When Ordering, Please Specify

1. Catalog No. 428-01 or No. 628-01
2. Valve Size
3. Pattern - Globe or Angle
4. Pressure Class
5. Materials Desired
6. Threaded or Flanged
7. Valve Closing or Valve Opening on Rising Water Level
8. Desired Options



Distributed By:
 M&M Control Service, INC.
 Phone: 800-876-0036
 Fax: 847-356-0747
 Email: Sales@mmcontrol.com