



- **Accurate and Repeatable Level Control**
- **Proportional Flow**
- **Reliable Hydraulic Operation**
- **Drip-Tight Positive Shut-Off**
- **Completely Automatic Operation**

The Cla-Val Model 129-01/629-01 Float Valve maintains a relatively constant level in storage tanks and reservoirs by admitting flow into the tank in direct proportion to the flow out of the tank. It is a hydraulically operated, pilot controlled, diaphragm valve. The rotary disc type float operated pilot control is installed at the high liquid level in the reservoir and is connected via tubing or pipe to the main valve. As the liquid level changes, the float control proportionally opens or closes the main valve, keeping the liquid level nearly constant. If the check feature option is added and a pressure reversal occurs, the downstream pressure is admitted into the main valve cover chamber and the valve closes to prevent return flow.

Schematic Diagram

Item	Description
1	Hytrol (Main Valve)
2	X47A Ejector
3	Bell Reducer
4	CFM2 Float Control

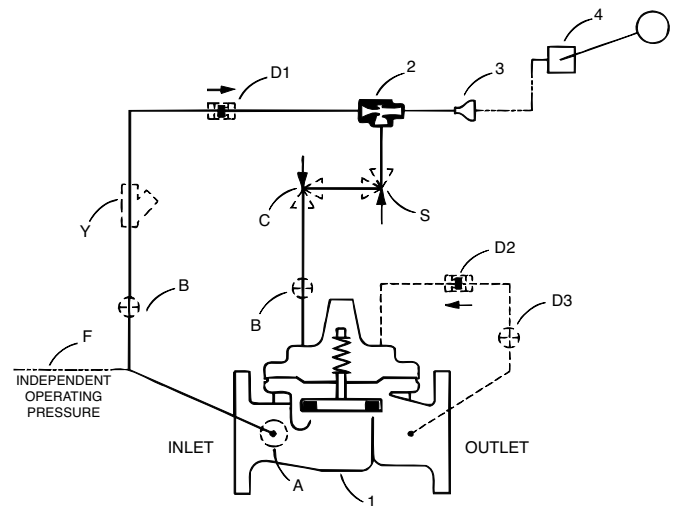

Optional Features

Item	Description
A	X46A Flow Cleaner Strainer
B	CK2 (Isolation Valve)
C	CV Flow Control (Closing)
D	Check Valves With Isolation Valve
F	Independent Operating Pressure
S	CV Flow Control (Opening)
Y	X43 "Y" Strainer

The "D" check feature on a vertically installed 6" and larger valves must be horizontally installed.

Typical Applications

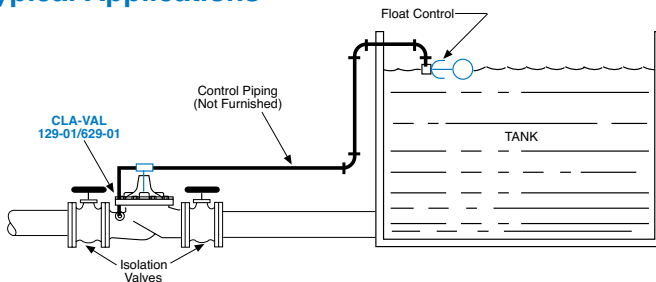

Piping and Tank Sizing

Install valve and control as shown in the diagram above. The float control should be located in a still liquid surface. If it is necessary to obtain this condition, a stilling well should be constructed. Mount the float control on the connecting piping with the outlet port at the desired high water level. When a separate source of supply pressure (Option F) is used by the pilot control system, that pressure must at all times be constant and equal to or greater than the pressure at the valve inlet.

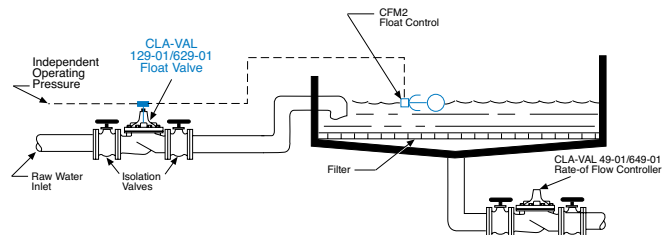

Filter Liquid Level Control

Maintains constant level in rapid sand filter. Usually requires the use of an independent operating pressure as shown.

Note: We recommend protecting tubing and valve from freezing temperatures.

Model 129-01 (Uses Basic Valve Model 100-01)

Pressure Ratings (Recommended Maximum Pressure - psi)

Valve Body & Cover		Pressure Class			
		Flanged		Threaded	
Grade	Material	ANSI Standards*	150 lb.	300 lb.	End** Details
ASTM A536	Ductile Iron	B16.42	250	400	400
ASTM A216-WCB	Cast Steel	B16.5	285	400	400
ASTM B62	Bronze	B16.24	225	400	400

Note: * ANSI standards are for flange dimensions only.
 Flanged valves are available faced but not drilled.
 ** End Details machined to ANSI B2.1 specifications.

Materials

Component	Standard Material Combinations		
Body & Cover	Ductile Iron	Cast Steel	Bronze
Available Sizes	1 1/4" - 36"	1 1/4" - 16"	1 1/4" - 16"
Disc Retainer & Diaphragm Washer	Cast Iron	Cast Steel	Bronze
Trim: Disc Guide, Seat & Cover Bearing	Bronze is Standard Stainless Steel is Optional		
Disc	Buna-N® Rubber		
Diaphragm	Nylon Reinforced Buna-N® Rubber		
Stem, Nut & Spring	Stainless Steel		

For material options not listed, consult factory.
 Cla-Val manufactures valves in more than 50 different alloys.

Dimensions
(In inches)

100-01 (Globe)

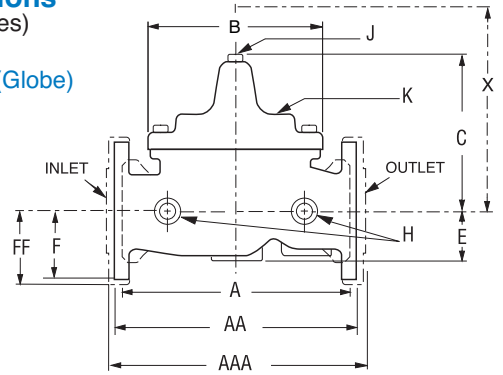

CFM2 FLOAT CONTROL

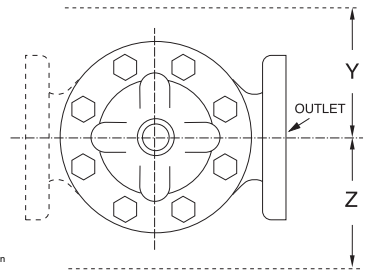
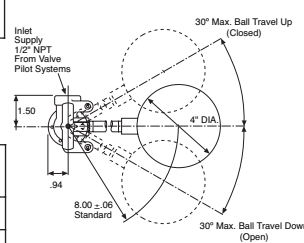

100-01 (Angle)

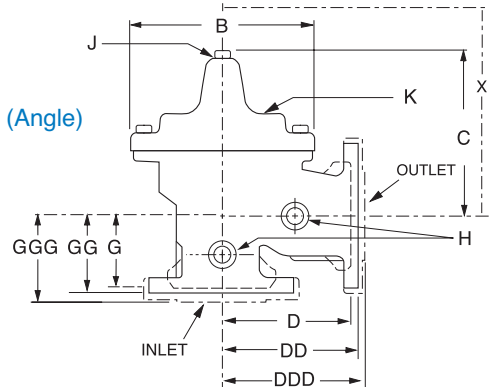

Model 129-01 Dimensions (In Inches)

Important Notice: Do Not Oversize

Valve Size (Inches)	1 1/4	2	2 1/2	3	4	6	8	10	12	14	16	24	36
A Threaded	7.25	9.38	11.00	12.50	—	—	—	—	—	—	—	—	—
AA 150 ANSI	8.50*	9.38	11.00	12.00	15.00	20.00	25.38	29.75	34.00	39.00	41.38	61.50	76.00
AAA 300 ANSI	9.00*	10.00	11.62	13.25	15.62	21.00	26.38	31.12	35.50	40.50	43.50	63.24	78.00
B Dia.	5.62	6.62	8.00	9.12	11.50	15.75	20.00	23.62	28.00	32.75	35.50	53.16	66.00
C Max.	5.50	6.50	7.56	8.19	10.62	13.38	16.00	17.12	20.88	24.19	25.00	43.93	61.50
D Threaded	3.25	4.75	5.50	6.25	—	—	—	—	—	—	—	—	—
DD 150 ANSI	4.00*	4.75	5.50	6.00	7.50	10.00	12.75	14.88	17.00	19.50	20.81	—	—
DDD 300 ANSI	4.25*	5.00	5.88	6.38	7.88	10.50	13.25	15.56	17.75	20.25	21.62	—	—
E	1.12	1.50	1.69	2.56	3.19	4.31	5.31	9.25	10.75	12.62	15.50	17.75	24.56
F 150 ANSI	2.50	3.00	3.50	3.75	4.50	5.50	6.75	8.00	9.50	10.50	11.75	19.25	28.00
FF 300 ANSI	3.06	3.25	3.75	4.13	5.00	6.25	7.50	8.75	10.25	11.50	12.75	—	—
G Threaded	1.88	3.25	4.00	4.50	—	—	—	—	—	—	—	—	—
GG 150 ANSI	4.00*	3.25	4.00	4.00	5.00	6.00	8.00	8.62	13.75	14.88	15.69	—	—
GGG 300 ANSI	4.25*	3.50	4.31	4.38	5.31	6.50	8.50	9.31	14.50	15.62	16.50	—	—
H NPT Body Tapping	3/8	3/8	1/2	1/2	3/4	3/4	1	1	1	1	1	1	2
J NPT Cover Center Plug	1/4	1/2	1/2	1/2	3/4	3/4	1	1	1 1/4	1 1/2	2	1 1/2	2
K NPT Cover Tapping	3/8	3/8	1/2	1/2	3/4	3/4	1	1	1	1	1	1	2
Valve Stem Internal Thread UNF	10-32	10-32	10-32	1/4-28	1/4-28	3/8-24	3/8-24	3/8-24	3/8-24	3/8-24	3/8-24	1/2-20	3/4-16
Stem Travel	0.4	0.6	0.7	0.8	1.1	1.7	2.3	2.8	3.4	4.0	4.5	6.75	10.12
Approx. Ship Wt. Lbs.	15	35	50	70	140	285	500	780	1165	1600	2265	6200	11470
X Pilot System	11.00	13.00	14.00	15.00	17.00	29.00	31.00	33.00	36.00	40.00	40.00	68.00	86.00
Y Pilot System	9.00	9.00	10.00	11.00	12.00	20.00	22.00	24.00	26.00	29.00	30.00	39.00	45.00
Z Pilot System	9.00	9.00	10.00	11.00	12.00	20.00	22.00	24.00	26.00	29.00	30.00	39.00	45.00

*1 1/2" Size Only

Model 629-01 (Uses Basic Valve Model 100-20)

Dimensions
(In inches)

Pressure Ratings (Recommended Maximum Pressure - psi)

Valve Body & Cover		Pressure Class		
		Flanged		
Grade	Material	ANSI Standards*	150 lb.	300 lb.
ASTM A536	Ductile Iron	B16.42	250	400
ASTM A216-WCB	Cast Steel	B16.5	285	400
ASTM B62	Bronze	B16.24	225	400

Note: *ANSI standards are for flange dimensions only.
Flanged valves are available faced but not drilled.

100-20 (Globe)

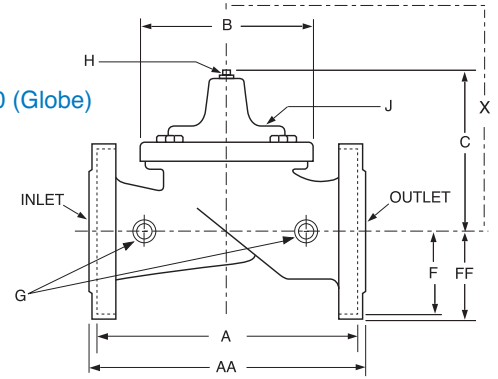

CFM2 FLOAT CONTROL

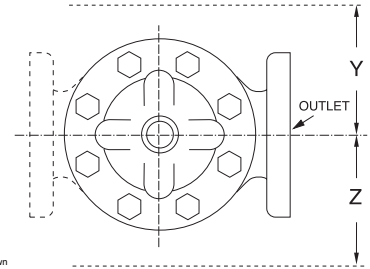
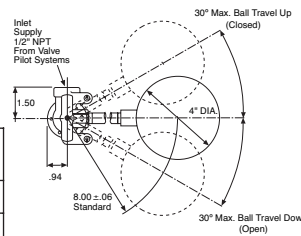

Materials

Component	Standard Material Combinations		
Body & Cover	Ductile Iron	Cast Steel	Bronze
Available Sizes	3" - 48"	3" - 16"	3" - 16"
Disc Retainer & Diaphragm Washer	Cast Iron	Cast Steel	Bronze
Trim: Disc Guide, Seat & Cover Bearing	Bronze is Standard Stainless Steel is Optional		
Disc	Buna-N® Rubber		
Diaphragm	Nylon Reinforced Buna-N® Rubber		
Stem, Nut & Spring	Stainless Steel		

For material options not listed, consult factory.
Cla-Val manufactures valves in more than 50 different alloys.



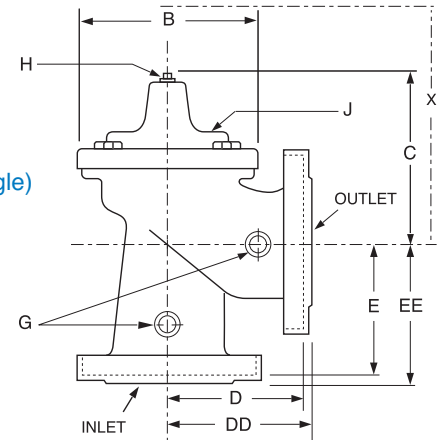







































100-20 (Angle)



Model 629-01 Dimensions (In Inches)

Important Notice: Do Not Oversize

Valve Size (Inches)	3	4	6	8	10	12	14	16	18	20	24	30
A 150 ANSI	10.25	13.88	17.75	21.38	26.00	30.00	34.25	35.00	42.12	48.00	48.00	63.25
AA 300 ANSI	11.00	14.50	18.62	22.38	27.38	31.50	—	36.62	43.63	49.62	49.75	—
B Dia.	6.62	9.12	11.50	15.75	20.00	23.62	28.00	28.00	35.44	35.44	35.44	53.19
C Max.	7.00	8.62	11.62	15.00	17.88	21.00	20.88	25.75	25.00	31.00	31.00	43.94
D 150 ANSI	—	6.94	8.88	10.69	—	—	—	—	—	—	—	—
DD 300 ANSI	—	7.25	9.38	11.19	—	—	—	—	—	—	—	—
E 150 ANSI	—	5.50	6.75	7.25	—	—	—	—	—	—	—	—
EE 300 ANSI	—	5.81	7.25	7.75	—	—	—	—	—	—	—	—
F 150 ANSI	3.75	4.50	5.50	6.75	8.00	9.50	11.00	11.75	15.88	14.56	17.00	19.88
FF 300 ANSI	4.12	5.00	6.25	7.50	8.75	10.25	—	12.75	15.88	16.06	19.00	—
H NPT Body Tapping	3/8	1/2	3/4	3/4	1	1	1	1	1	1	1	1
J NPT Cover Center Plug	1/2	1/2	3/4	3/4	1	1	1 1/4	1 1/4	2	2	2	2
K NPT Cover Tapping	3/8	1/2	3/4	3/4	1	1	1	1	1	1	1	1
Valve Stem Internal Thread UNF	10-32	1/4-28	1/4-28	3/8-24	3/8-24	3/8-24	3/8-24	3/8-24	1/2-20	1/2-20	1/2-20	3/4-16
Stem Travel	0.6	0.8	1.1	1.7	2.3	2.8	3.4	3.4	3.4	4.5	4.5	6.5
Approx. Ship Wt. Lbs.	45	85	195	330	625	900	1250	1380	1500	2551	2733	6500
X Pilot System	13.00	15.00	27.00	30.00	33.00	36.00	36.00	41.00	40.00	46.00	55.00	68.00
Y Pilot System	10.00	11.00	18.00	20.00	22.00	24.00	26.00	26.00	30.00	30.00	30.00	39.00
Z Pilot System	10.00	11.00	18.00	20.00	22.00	24.00	26.00	26.00	30.00	30.00	30.00	39.00

Valve Selection		These Symbols  and  Indicate Available Sizes																		
		Inches	1¼	1½	2	2½	3	4	6	8	10	12	14	16	18	20	24	30	36	
		mm	32	40	50	65	80	100	150	200	250	300	350	400	450	500	600	750	900	
End Detail		Threaded	Threaded & Flanged				Flanged													
Model 129-01	Basic Valve 100-01	Globe																		
		Angle																		
	Suggested Flow (gpm)	Normal Continuous	93	125	210	300	460	800	1800	3100	4900	7000	8400	11000				25000		50000
	Suggested Flow (Liters/Sec)	Normal Continuous	6	8	13	19	29	50	113	195	309	441	529	693				1575		3150
Model 629-01	Basic Valve 100-20	Globe																		
		Angle																		
	Suggested Flow (gpm)	Normal Continuous					260	580	1025	2300	4100	6400	9230	9230	16500	16500	16500	28000		
	Suggested Flow (Liters/Sec)	Normal Continuous					16	37	65	145	258	403	581	581	1040	1040	1040	1764		

**Flanged End Detail Only

629-01 is the reduced internal port size version of the 129-01.

For 100-01 basic valves, suggested flow calculations were based on flow through Schedule 40 Pipe. Normal continuous flow is approx. 20 ft/sec (6.1 meters/sec) .
 For 100-20 basic valves, suggested flow calculations were based on flow through the valve seat. Approx. 26 ft/sec (7.9 meters/sec) is used for normal continuous flow.
 Normal continuous flow through the valve seat for the 30" 100-20 is approx. 20 ft/sec (6.1 meters/sec).

We recommend providing adequate space around valve for maintenance work

Important Notice: Do Not Oversize

Pilot System Specifications

Pressure Rating

Maximum: 300 psi

Temperature Range

Water: to 180°F

Materials

Pilot Control System:
 Cast Bronze ASTM B-62 with
 303 Stainless Steel Trim, Bronze
 fittings and copper tubing.

Optional Materials

Aluminum, Bronze and Stainless Steel
 available at additional cost.

Control Piping (customer supplied)

Use either copper tubing or brass pipe
 between CFM2 Float Control and the main
 valve pilot system.

1/2" dia. for distances less than 25 feet;

3/4" dia. for greater distances.

**When Ordering,
 Please Specify**

1. Catalog No. 129-01 or No. 629-01
2. Valve Size
3. Pattern - Globe or Angle
4. Pressure Class
5. Threaded or Flanged
6. Materials Desired
7. Desired Options
8. When Vertically Installed



Distributed By:
 M&M Control Service, INC.
 Phone: 800-876-0036
 Fax: 847-356-0747
 Email: Sales@mmcontrol.com