

Float Valve

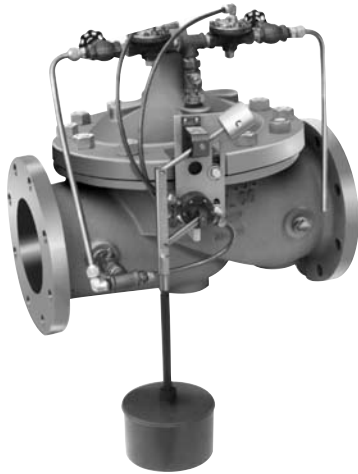

- **Accurate and Repeatable Level Control**
- **On-Off Non-Modulating Action**
- **Fully Adjustable High and Low Level Settings**
- **Simple Design, Proven Reliable**
- **Easy Installation and Maintenance**

The Cla-Val Model 124-02/624-02 Float Valve is a non-modulating valve that accurately controls the liquid level in tanks. This valve is designed to open fully when the liquid level reaches a preset low point, and close drip-tight when the level reaches a preset high point.

This is a hydraulically operated, diaphragm valve with the pilot control and float mechanism mounted on the cover of the main valve. The float positions the pilot control to close the valve when the float contacts the upper stop. The high and low liquid levels are adjusted by positioning the stop collars on the float rod. The difference between high and low levels can be adjusted to as little as an inch, or to as much as eighteen inches. Level settings can be as much as eleven and one-half feet below the valve. The float mechanism may be located remotely from the main valve. See the technical data sheet on Model CF1-C1 Float Control for additional information.

Schematic Diagram

Item	Description
1	100-01 Hytrol (Main Valve)
2	CF1-C1 Float Control
3	100-01 Hytrol (Reverse Flow)
4	CGB Globe Valve

Optional Features

Item	Description
A	X46A Flow Clean Strainer
B	CK2 (Isolation Valve)
F	Independent Operating Pressure
S	CGB Globe Valve
Y	X43 "Y" Strainer

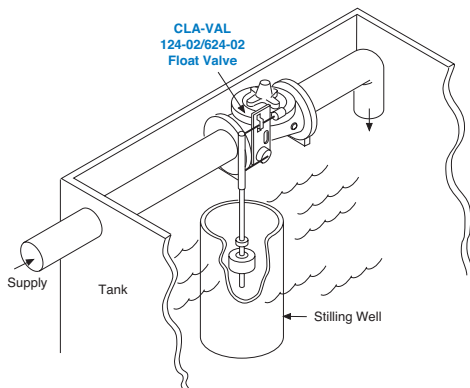
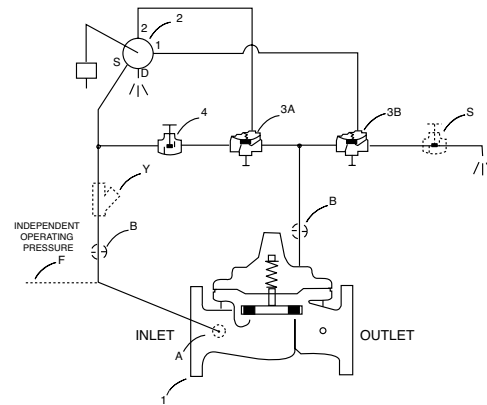

Typical Applications

The Model 124-02/624-02 Float Valve is commonly mounted above the high water level in a tank. Globe pattern valves are supplied standard with the float control mounted on the right side of the cover as illustrated, with a horizontal discharge. Angle valves are configured to discharge downward.

Note: We recommend protecting tubing and valve from freezing temperatures.

Installation

A stilling well (8" minimum diameter) must be provided around the float if the liquid surface is subject to turbulence, ripples or wind. When the valve is mounted on top of the tank roof, a 2" clearance hole should be provided for side movement of the float rod where

the rod goes through the top of the tank.

An independent source of air or water may be used to operate the valve (option F). The pressure from this independent source must at all times be equal to or greater than pressure at the valve inlet.

If minimum flowing line pressure is less than 10 psi, consult Cla-Val for full details.

If the float control is remotely mounted from the main valve, the control may be installed at any elevation above the valve, provided the flowing line pressure in psi is equal to or greater than the vertical distance in feet between the valve and the float control. See the data sheet on Model CF1-C1 for additional information.

Model 124-02 (Uses Basic Valve Model 100-01)

Pressure Ratings (Recommended Maximum Pressure - psi)

Valve Body & Cover		Pressure Class			
		Flanged		Threaded	
Grade	Material	ANSI Standards*	150 lb.	300 lb.	End** Details
ASTM A536	Ductile Iron	B16.42	250	400	400
ASTM A216-WCB	Cast Steel	B16.5	285	400	400
ASTM B62	Bronze	B16.24	225	400	400

Note: * ANSI standards are for flange dimensions only.
 Flanged valves are available faced but not drilled.
 ** End Details machined to ANSI B2.1 specifications.

Materials

Component	Standard Material Combinations		
Body & Cover	Ductile Iron	Cast Steel	Bronze
Available Sizes	8" - 36"	8" - 16"	8" - 16"
Disc Retainer & Diaphragm Washer	Cast Iron	Cast Steel	Bronze
Trim: Disc Guide, Seat & Cover Bearing	Bronze is Standard Stainless Steel is Optional		
Disc	Buna-N® Rubber		
Diaphragm	Nylon Reinforced Buna-N® Rubber		
Stem, Nut & Spring	Stainless Steel		

For material options not listed, consult factory.
 Cla-Val manufactures valves in more than 50 different alloys.

Dimensions
(In inches)

100-01 (Globe)

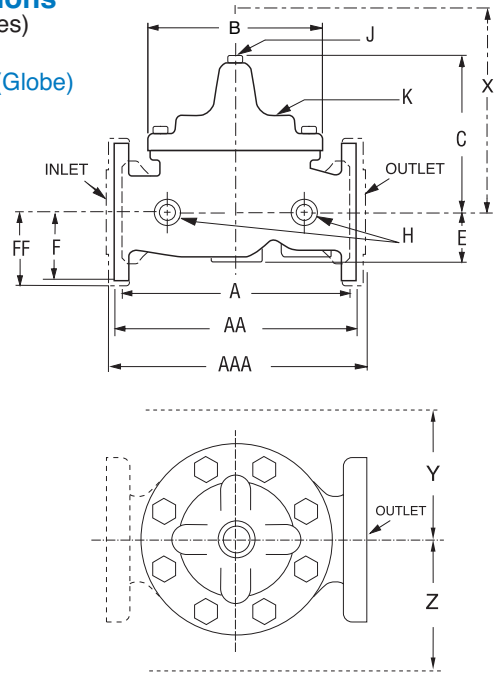

100-01 (Angle)

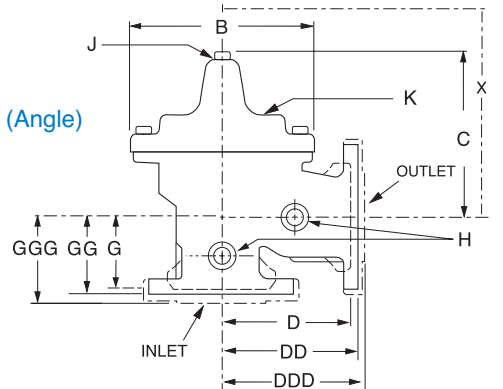

Model 124-02 Dimensions (In Inches)

Valve Size (Inches)	8	10	12	14	16	24	36
A Threaded	—	—	—	—	—	—	—
AA 150 ANSI	25.38	29.75	34.00	39.00	41.38	61.50	76.00
AAA 300 ANSI	26.38	31.12	35.50	40.50	43.50	63.24	78.00
B Dia.	20.00	23.62	28.00	32.75	35.50	53.16	66.00
C Max.	16.00	17.12	20.88	24.19	25.00	43.93	61.50
D Threaded	—	—	—	—	—	—	—
DD 150 ANSI	12.75	14.88	17.00	19.50	20.81	—	—
DDD 300 ANSI	13.25	15.56	17.75	20.25	21.62	—	—
E	5.31	9.25	10.75	12.62	15.50	17.75	24.56
F 150 ANSI	6.75	8.00	9.50	10.50	11.75	19.25	28.00
FF 300 ANSI	7.50	8.75	10.25	11.50	12.75	—	—
G Threaded	—	—	—	—	—	—	—
GG 150 ANSI	8.00	8.62	13.75	14.88	15.69	—	—
GGG 300 ANSI	8.50	9.31	14.50	15.62	16.50	—	—
H NPT Body Tapping	1	1	1	1	1	1	2
J NPT Cover Center Plug	1	1	1¼	1½	2	1½	2
K NPT Cover Tapping	1	1	1	1	1	1	2
Valve Stem Internal Thread UNF	¾-24	¾-24	¾-24	¾-24	½-20	¾-16	¾-16
Stem Travel	2.3	2.8	3.4	4.0	4.5	6.75	10.12
Approx. Ship Wt. Lbs.	500	780	1165	1600	2265	6200	11470

Model 624-02 (Uses Basic Valve Model 100-20)

Dimensions
(In inches)

Pressure Ratings (Recommended Maximum Pressure - psi)

Valve Body & Cover		Pressure Class		
		Flanged		
Grade	Material	ANSI Standards*	150 lb.	300 lb.
ASTM A536	Ductile Iron	B16.42	250	400
ASTM A216-WCB	Cast Steel	B16.5	285	400
ASTM B62	Bronze	B16.24	225	400

Note: *ANSI standards are for flange dimensions only.
Flanged valves are available faced but not drilled.

Materials

Component	Standard Material Combinations		
Body & Cover	Ductile Iron	Cast Steel	Bronze
Available Sizes	10" - 48"	10" - 16"	10" - 16"
Disc Retainer & Diaphragm Washer	Cast Iron	Cast Steel	Bronze
Trim: Disc Guide, Seat & Cover Bearing	Bronze is Standard Stainless Steel is Optional		
Disc	Buna-N® Rubber		
Diaphragm	Nylon Reinforced Buna-N® Rubber		
Stem, Nut & Spring	Stainless Steel		

For material options not listed, consult factory.
Cla-Val manufactures valves in more than 50 different alloys.

100-20 (Globe)

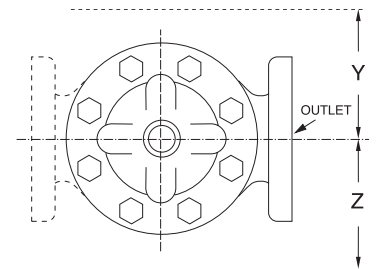
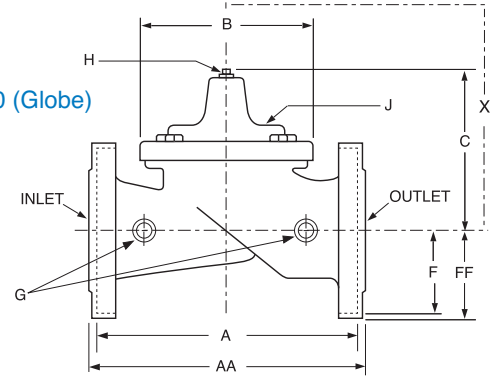

100-20 (Angle)

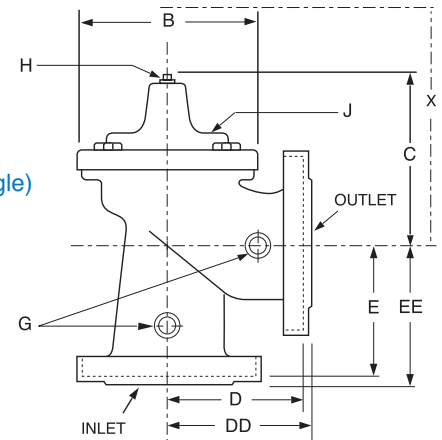

Model 624-02 Dimensions (In Inches)

Valve Size (Inches)	10	12	14	16	18	20	24	30
A 150 ANSI	26.00	30.00	34.25	35.00	42.12	48.00	48.00	63.25
AA 300 ANSI	27.38	31.50	—	36.62	43.63	49.62	49.75	—
B Dia.	20.00	23.62	28.00	28.00	35.44	35.44	35.44	53.19
C Max.	17.88	21.00	20.88	25.75	25.00	31.00	31.00	43.94
D 150 ANSI	—	—	—	—	—	—	—	—
DD 300 ANSI	—	—	—	—	—	—	—	—
E 150 ANSI	—	—	—	—	—	—	—	—
EE 300 ANSI	—	—	—	—	—	—	—	—
F 150 ANSI	8.00	9.50	11.00	11.75	15.88	14.56	17.00	19.88
FF 300 ANSI	8.75	10.25	—	12.75	15.88	16.06	19.00	—
H NPT Body Tapping	1	1	1	1	1	1	1	1
J NPT Cover Center Plug	1	1	1 1/4	1 1/4	2	2	2	2
K NPT Cover Tapping	1	1	1	1	1	1	1	1
Valve Stem Internal Thread UNF	3/8-24	3/8-24	3/8-24	3/8-24	1/2-20	1/2-20	1/2-20	3/4-16
Stem Travel	2.3	2.8	3.4	3.4	3.4	4.5	4.5	6.5
Approx. Ship Wt. Lbs.	625	900	1250	1380	1500	2551	2733	6500

Valve Selection		Inches	8	10	12	14	16	18	20	24	30	36
		mm	200	250	300	350	400	450	500	600	750	900
		End Detail	Flanged									
Model 124-02	Basic Valve 100-01	Globe										
		Angle										
	Suggested Flow (gpm)	Max. Continuous	3100	4900	7000	8400	11000			25000		50000
		Max. Intermittent	68	120	160	10540	13700			31300		62500
	Suggested Flow (Liters/Sec)	Max. Continuous	195.3	308.7	441	529	693			1575		3150
Max. Intermittent		4.3	7.6	10	664	863			1972		3940	
Model 624-02	Basic Valve 100-20	Globe										
		Angle										
	Suggested Flow (gpm)	Max. Continuous		4100	6400	9230	9230	16500	16500	16500	28000	
		Max. Intermittent										
Suggested Flow (Liters/Sec)	Max. Continuous		258	403	851	581	1040	1040	1040	1764		
	Max. Intermittent											

624-02 is the reduced internal port size version of the 124-02.

For 100-01 basic valves, suggested flow calculations were based on flow through Schedule 40 Pipe. Maximum continuous flow is approx. 20 ft/sec (6.1 meters/sec) & maximum intermittent is approx. 25 ft/sec (7.6 meters/sec). For 100-20 basic valves, suggested flow calculations were based on flow through the valve seat. Approx. 26 ft/sec (7.9 meters/sec) is used for maximum continuous flow. Maximum continuous flow through the valve seat of the 30" 100-20 is approx 20 ft/sec (6.1 meters/sec).

*See the 124-01/624-01 Technical Data Sheet for smaller sizes.

**Pilot System Dimensions
(In Inches)**

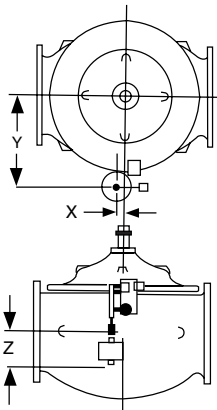

GLOBE 124-02 8" to 16"
624-02 10" to 30"

124-02 Float Valve (Globe)						
Size	8"	10"	12"	14"	16"	24"
X	1.25	1.25	1.00	.50	.25	1.25
Y	12.75	14.75	17.00	19.50	21.00	30.00
Z (Max)	48.25	47.00	45.25	44.50	43.25	32.00

124-02 Float Valve (Angle)					
Size	8"	10"	12"	14"	16"
X	1.25	1.25	1.00	.50	.25
Y	12.75	14.75	17.00	19.50	21.00
Z (Max)*	48.25	47.00	45.25	44.50	43.25

624-02 Float Valve (Globe)							
Size	10"	12"	16"	18"	20"	24"	30"
X	1.25	1.25	1.00	1.00	.25	.25	.25
Y	12.75	14.75	17.00	17.00	21.00	21.00	30.00
Z (Max)*	45.00	43.00	40.25	40.25	36.75	36.75	32.00

*Z(Max) is with standard float rod

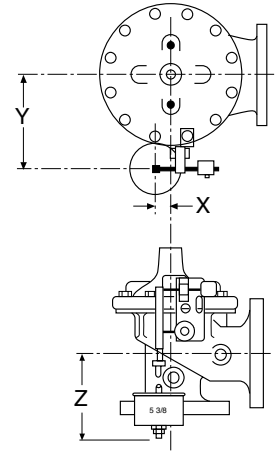

ANGLE 124-02 8" to 16"

Pilot System Specifications

Pressure Rating

300 psi Max.

Temperature Rating

Water: to 180°F. Max.

Materials

In contact with operating fluid: Brass, Stainless Steel, Monel, with Buna-N® seals
 Float linkage and float rod: Brass and PVC
 Base plate: Treated Steel
 Float: Polypropylene

Float

5 3/8" diameter. If maximum temperature exceeds 160°F specify stainless steel float and rod. Available at additional cost

Float Rod

Standard: Two 12" sections of PVC rod, with 12" extension increments at extra cost.
 Optional: 24" stainless steel rod, with 24" extension increments at extra cost.
 larger counterweight is required if float rod length exceeds 2'.

Adjustment Range

Level Differential:
 1" min. to 18" max. with PVC rod.
 1" min to 40" max. with stainless steel rod.

Operating Fluids

Clean liquids or gases compatible with specified materials.

When Ordering, Please Specify

1. Catalog No. 124-02 or No. 624-02
2. Valve Size
3. Pattern - Globe or Angle
4. Pressure Class
5. Threaded or Flanged
6. Float Rod Material and Length
7. Float Ball Material
8. Desired Options
9. When Vertically Installed



Distributed By:
 M&M Control Service, INC.
 Phone: 800-876-0036
 Fax: 847-356-0747
 Email: Sales@mmcontrol.com