



— MODEL —

40-01/640-01

Rate of Flow Control Valve

INTRODUCTION

The Cla-Val 40-01/640-01 is an automatic valve designed to limit the maximum flow rate regardless of changing line pressure. It is hydraulically operated, pilot-controlled, diaphragm type globe or angle valve. The pilot control is actuated by the differential pressure produced across an orifice plate restriction installed downstream of the valve. Accurate control is insured as very small changes in the controlling differential produce immediate corrective action of the main valve. Rate of flow is adjustable by varying the spring loading on the pilot control.

INSTALLATION

1. Allow sufficient room around the valve to make adjustments and for disassembly.

2. It is recommended that either gate or block valves be installed on both ends of the Cla-Val Valve to facilitate isolating the valve for preventive maintenance.

NOTE: BEFORE THE VALVE IS INSTALLED, PIPE LINES SHOULD BE FLUSHED OF ALL CHIPS, SCALE, AND FOREIGN MATTER.

3. Place valve in line with flow through the valve in the direction indicated on the inlet plate or by flow arrows. Check all fittings and hardware for proper makeup and that no apparent damage is evident. Be sure main valve cover nuts/bolts are tight. Pressure in some applications can be very high, be thorough in checking and inspecting for proper installation and makeup.

4. For best control, it is recommended that the orifice plate restriction be installed 1 to 5 pipe diameters downstream of the main valve. The flow arrows should be pointing to the downstream side of the system.

5. A sensing line, supplied by other than Cla-Val, must be connected between the orifice plate holder (4) and the Differential Control (3). See dotted lines on schematic drawing.

6. Cla-Val Valves operate with maximum efficiency when mounted in horizontal piping with the cover UP; however, other positions are acceptable. Due to size and weight of cover and internal components of six inch and larger valves, installation with the cover up is advisable. This makes periodic inspection of internal parts readily accessible.

OPERATING AND START-UP

1. Prior to pressurizing the valve assembly make sure the necessary gauges to measure pressure in the system are installed as required by the system engineer. A Cla-Val X101 Valve Position Indicator may be installed in the center cover port to provide visual indication of the valve diaphragm assembly position during startup.

CAUTION: During startup and test procedures a large volume of water may be discharged downstream. Check that the downstream venting is adequate to prevent damage to personnel and equipment. All adjustments in pressure should be made slowly. If the main valve closes too fast it may cause surging in upstream piping.

2. With the downstream block valve closed, slowly open upstream block valve. If isolation valves (B) are installed in the pilot system, open these valves.(see schematic)

3. Carefully loosen the plug at top of cover assembly. If an indicator (X101) is installed, loosen the bleed valve at top of indicator. Bleed air from cover and tighten plug or bleed valve.

4. Carefully loosen tubing fittings at highest points and bleed air from system. Retighten fittings.

NOTE: Be sure the sensing line, (dotted line shown on schematic) which connects the orifice plate holder (4) to the CDHS-18 Control (3) is installed. The 40-01/640-01 Rate of Flow Control Valve will not function unless this sensing line is installed. Be sure to bleed air from this sensing line at the CDHS-18 Control fitting.

5. Slowly open downstream block valve and adjust the CDHS-18 Control for required flow rate. Turn the adjustment screw clockwise to increase flow rate and counterclockwise to decrease flow rate. The adjustment screw should be turned slowly. A good procedure is to make one adjustment turn with a pause to let the system stabilize.

MAINTENANCE AND INSPECTION

1. Cla-Val Valves and Controls require no lubrication or packing and a minimum of maintenance. However, a periodic inspection schedule should be established to determine how the fluid handled is affecting the operation of the valve assembly. Minimum of once per year.

2. Repair and maintenance procedures of the Hytrol Main Valve and control components are included in a more detailed IOM manual. It can be downloaded from our web site (www.cla-val.com) or obtained by contacting a Cla-Val Regional Sales Office.

3. When ordering parts always refer to the catalog number and stock number on the valve nameplate.

SYMPTOM	POSSIBLE CAUSE	SOLUTIONS
Main valve won't open	Orifice plate assembly and/or orifice sensing line clogged	Remove line and clean orifice port Clean or replace line
	Adjustment below desired set point	Readjust control
	Control line shutoff valve to cover or main outlet closed	Open shutoff valve
	Pilot valve stuck closed Mineral deposits or foreign matter under disc retainer assembly	Remove plug and disc retainer assembly clean or replace
	Main valve stuck closed Mineral buildup on stem Stem damaged Diaphragm leaks	Disassemble main valve clean parts and/or replace damaged parts
Main valve won't close	Adjustment above desired set point	Readjust control
	Pilot control diaphragm nut loose or diaphragm leaks (damaged)	Disassemble tighten nut or replace diaphragm
	Clogged restriction assembly	Remove and clean or replace
	Control line shutoff valve from inlet to restriction closed	Open shutoff valve and readjust
	CV Flow control closed or clogged	Disassembled and clean
	Pilot control disc worn or nicked	Remove disc retainer assembly and replace

40-01/640-01 SCHEMATIC

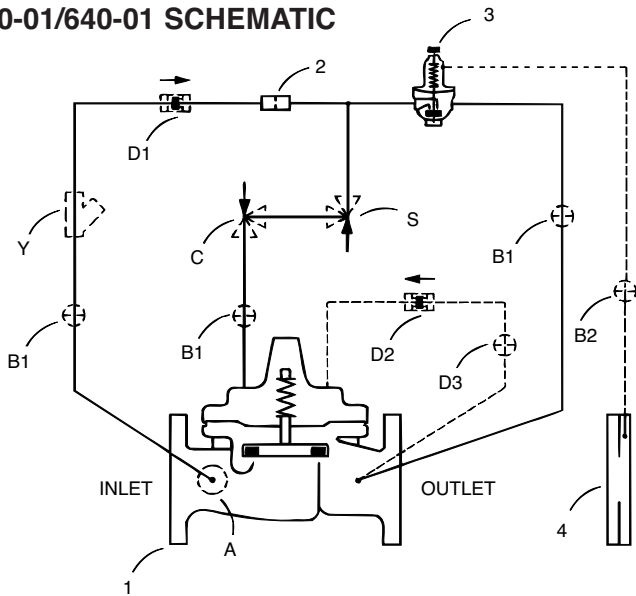

BASIC COMPONENTS

- 1 100-01 Hytrol (Main Valve)
100-20 600 Series Hytrol (Main Valve)
- 2 X58C Restriction Fitting
- 3 CDHS18 Differential Control
- 4 X52E Orifice Plate Assembly

OPTIONAL FEATURES

- A X46A Flow Clean Strainer
- B CK2 Valve (Isolation Valve)
- C CV Flow Control (Closing)
- D Check Valves with Isolation Valve
- S CV Flow Control (Opening)
- Y X43 "Y" Strainer

1. HYTROL MAIN VALVE

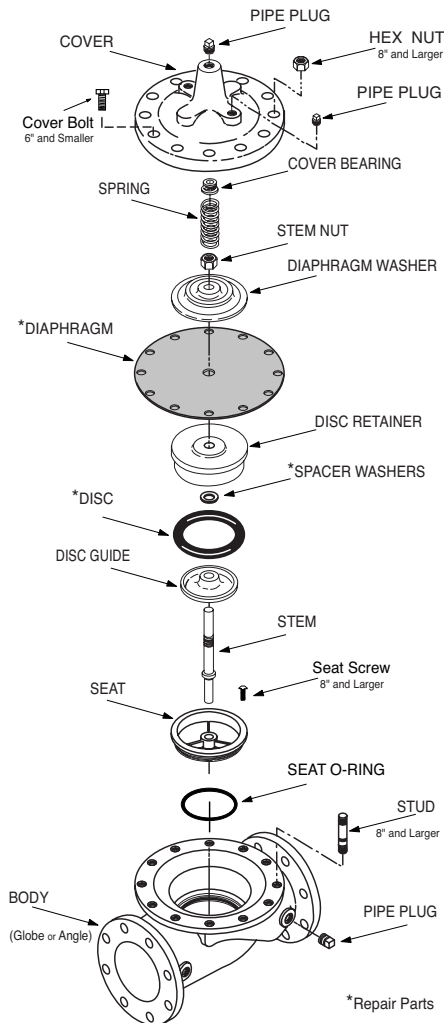

*Repair Parts

CDHS18

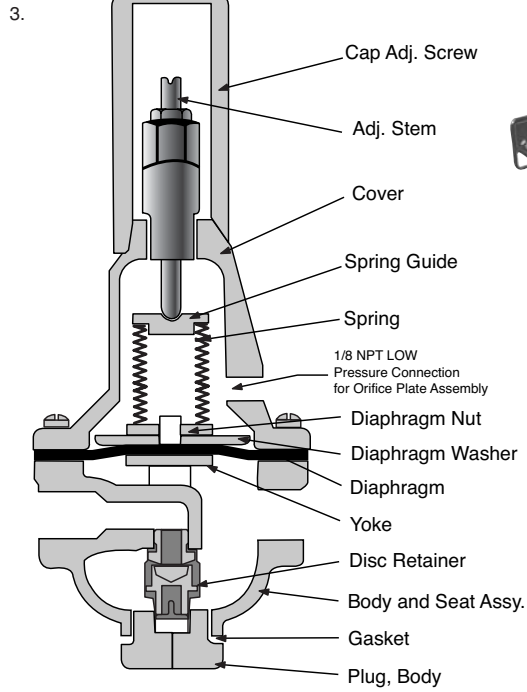

X140-1 Security Cap Option



X58C

2.



X52E

4.

Flow →



CDHS18

3.



X46A

A.



CK2

B.



CV

C.



CDC-1

D.



X43

Y.



*SUGGESTED REPAIR PARTS

For a more detailed IOM Manual go to www.cla-val.com or contact a Cla-Val Regional Sales Office.

Distributed By: M&M Control Service, INC.

Phone: 800-876-0036 Fax: 847-356-0747 Email: Sales@mmcontrol.com