

Rate of Flow Control Valve

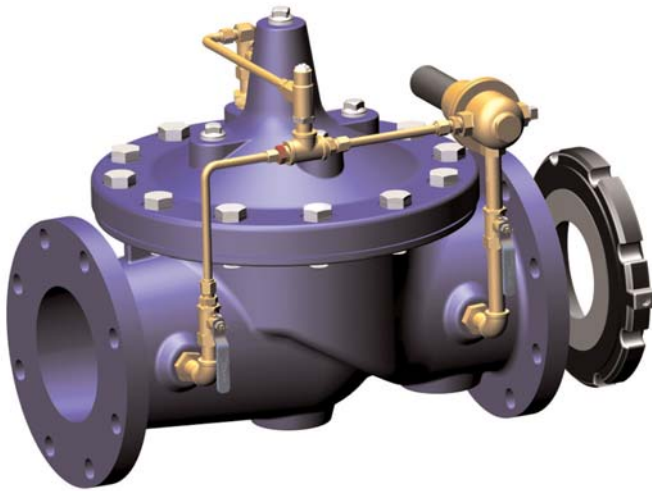

- **Accurately Limits Flow Rate**
- **Completely Automatic Operation**
- **Includes Orifice Plate with Holder**
- **Optional Check Feature**
- **Easily Adjusted**

The Cla-Val Model 40-01/640-01 Rate of Flow Control Valve prevents excessive flow by limiting flow to a preselected maximum rate, regardless of changing line pressure. It is a hydraulically operated, pilot controlled, diaphragm valve. The pilot control responds to the differential pressure produced across an orifice plate installed downstream of the valve. Accurate control is assured as very small changes in the controlling differential pressure produce immediate corrective action of the main valve. Flow rate adjustments are made by turning an adjusting screw on the pilot control.

The Model 40-01/640-01 includes an orifice plate with a holder that should be installed one to five pipe diameters downstream of the valve. If the check feature option is added and a pressure reversal occurs, the downstream pressure is admitted into the main valve cover chamber and the valve closes to prevent return flow. See X52E data sheet for sizing selection.

Schematic Diagram

Item	Description
1	Hytrol (Main Valve)
2	X58C Restricting Fitting
3	CDHS18 Differential Control
4	X52E Orifice Plate Assembly

Optional Features

Item	Description
A	X46A Flow Clean Strainer
B	CK2 (Isolation Valve)
C	CV Flow Control (Closing)
D	Check Valves with Isolation Valve
S	CV Flow Control (Opening)
Y	X43 "Y" Strainer

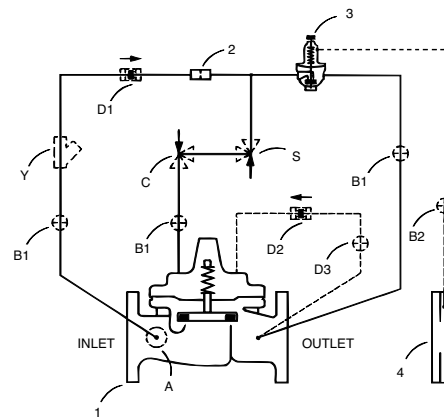

The "D" check feature on a vertically installed 6" and larger valves must be horizontally installed.

Typical Applications

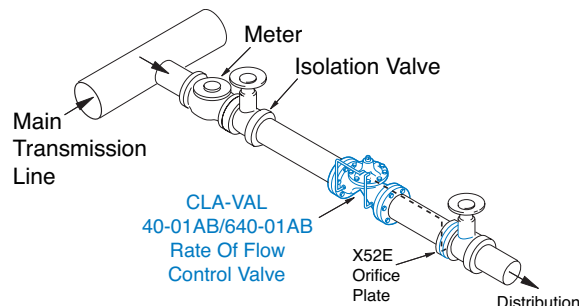

The 40-01/640-01 is typically installed where water supply to a system must be limited to a preset maximum flow rate. The valve is easily set to maintain the maximum allowable flow rate.

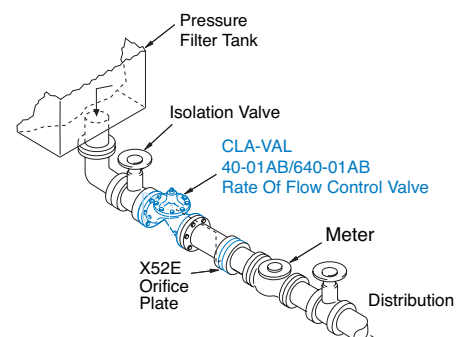

The 40-01/640-01 is typically installed as a pressure type filter effluent control valve where a constant flow rate is maintained as head loss through the filter varies.

Model 40-01 (Uses Basic Valve Model 100-01)

Pressure Ratings (Recommended Maximum Pressure - psi)

Valve Body & Cover		Pressure Class			
		Flanged		Threaded	
Grade	Material	ANSI Standards*	150 lb.	300 lb.	End** Details
ASTM A536	Ductile Iron	B16.42	250	400	400
ASTM A216-WCB	Cast Steel	B16.5	285	400	400
ASTM B62	Bronze	B16.24	225	400	400

Note: * ANSI standards are for flange dimensions only.
Flanged valves are available faced but not drilled.
** End Details machined to ANSI B2.1 specifications.

Materials

Component	Standard Material Combinations		
Body & Cover	Ductile Iron	Cast Steel	Bronze
Available Sizes	1½" - 36"	1½" - 16"	1½" - 16"
Disc Retainer & Diaphragm Washer	Cast Iron	Cast Steel	Bronze
Trim: Disc Guide, Seat & Cover Bearing	Bronze is Standard Stainless Steel is Optional		
Disc	Buna-N® Rubber		
Diaphragm	Nylon Reinforced Buna-N® Rubber		
Stem, Nut & Spring	Stainless Steel		

For material options not listed, consult factory.
Cla-Val manufactures valves in more than 50 different alloys.

Dimensions (In inches)

100-01 (Globe)

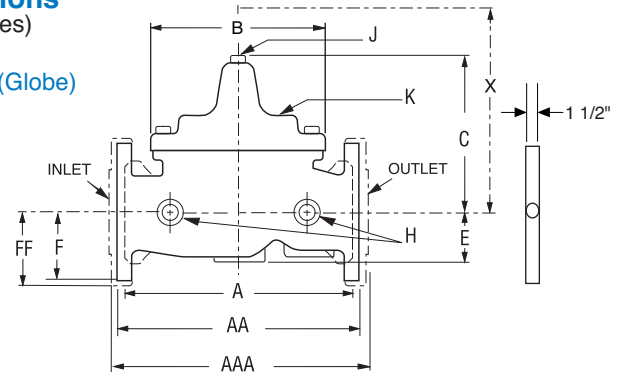

100-01 (Angle)

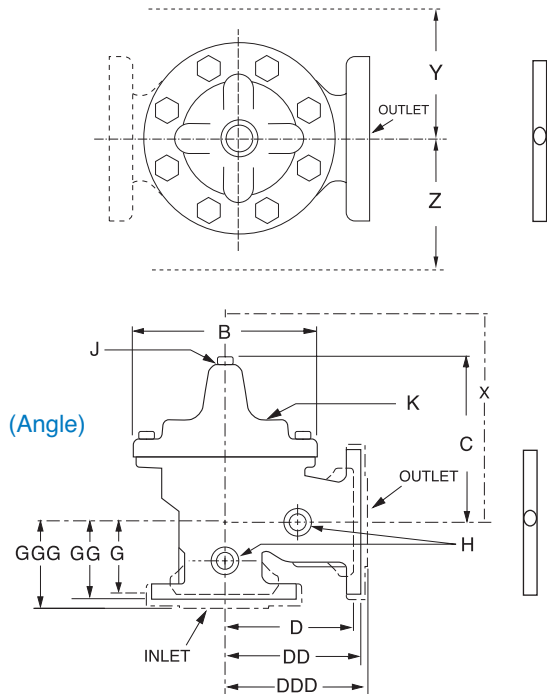

Model 40-01 Dimensions (In Inches)

Valve Size (Inches)	1½	2	2½	3	4	6	8	10	12	14	16	24	36
A Threaded	7.25	9.38	11.00	12.50	—	—	—	—	—	—	—	—	—
AA 150 ANSI	8.50*	9.38	11.00	12.00	15.00	20.00	25.38	29.75	34.00	39.00	41.38	61.50	76.00
AAA 300 ANSI	9.00*	10.00	11.62	13.25	15.62	21.00	26.38	31.12	35.50	40.50	43.50	63.24	78.00
B Dia.	5.62	6.62	8.00	9.12	11.50	15.75	20.00	23.62	28.00	32.75	35.50	53.16	66.00
C Max.	5.50	6.50	7.56	8.19	10.62	13.38	16.00	17.12	20.88	24.19	25.00	43.93	61.50
D Threaded	3.25	4.75	5.50	6.25	—	—	—	—	—	—	—	—	—
DD 150 ANSI	4.00*	4.75	5.50	6.00	7.50	10.00	12.75	14.88	17.00	19.50	20.81	—	—
DDD 300 ANSI	4.25*	5.00	5.88	6.38	7.88	10.50	13.25	15.56	17.75	20.25	21.62	—	—
E	1.12	1.50	1.69	2.56	3.19	4.31	5.31	9.25	10.75	12.62	15.50	17.75	24.56
F 150 ANSI	2.50	3.00	3.50	3.75	4.50	5.50	6.75	8.00	9.50	10.50	11.75	19.25	28.00
FF 300 ANSI	3.06	3.25	3.75	4.13	5.00	6.25	7.50	8.75	10.25	11.50	12.75	—	—
G Threaded	1.88	3.25	4.00	4.50	—	—	—	—	—	—	—	—	—
GG 150 ANSI	4.00*	3.25	4.00	4.00	5.00	6.00	8.00	8.62	13.75	14.88	15.69	—	—
GGG 300 ANSI	4.25*	3.50	4.31	4.38	5.31	6.50	8.50	9.31	14.50	15.62	16.50	—	—
H NPT Body Tapping	¾	¾	½	½	¾	¾	1	1	1	1	1	1	2
J NPT Cover Center Plug	¼	½	½	½	¾	¾	1	1	1¼	1½	2	1½	2
K NPT Cover Tapping	¾	¾	½	½	¾	¾	1	1	1	1	1	1	2
Valve Stem Internal Thread UNF	10-32	10-32	10-32	¼-28	¼-28	¾-24	¾-24	¾-24	¾-24	¾-24	¾-24	½-20	¾-16
Stem Travel	0.4	0.6	0.7	0.8	1.1	1.7	2.3	2.8	3.4	4.0	4.5	6.75	10.12
Approx. Ship Wt. Lbs.	15	35	50	70	140	285	500	780	1165	1600	2265	6200	11470
X Pilot System	11.00	13.00	14.00	15.00	17.00	29.00	31.00	33.00	36.00	40.00	40.00	68.00	86.00
Y Pilot System	9.00	9.00	10.00	11.00	12.00	20.00	22.00	24.00	26.00	29.00	30.00	39.00	45.00
Z Pilot System	9.00	9.00	10.00	11.00	12.00	20.00	22.00	24.00	26.00	29.00	30.00	39.00	45.00

*1½" Size Only

Model 640-01 (Uses Basic Valve Model 100-20)

Dimensions
(In inches)

Pressure Ratings (Recommended Maximum Pressure - psi)

Valve Body & Cover		Pressure Class		
		Flanged		
Grade	Material	ANSI Standards*	150 lb.	300 lb.
ASTM A536	Ductile Iron	B16.42	250	400
ASTM A216-WCB	Cast Steel	B16.5	285	400
ASTM B62	Bronze	B16.24	225	400

Note: *ANSI standards are for flange dimensions only.
Flanged valves are available faced but not drilled.

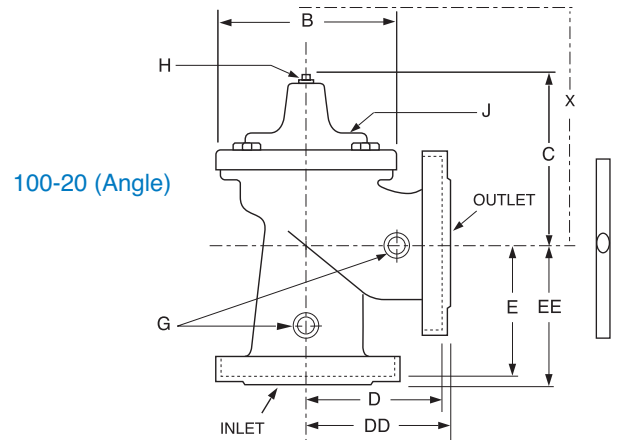
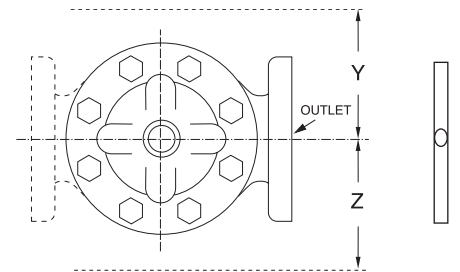
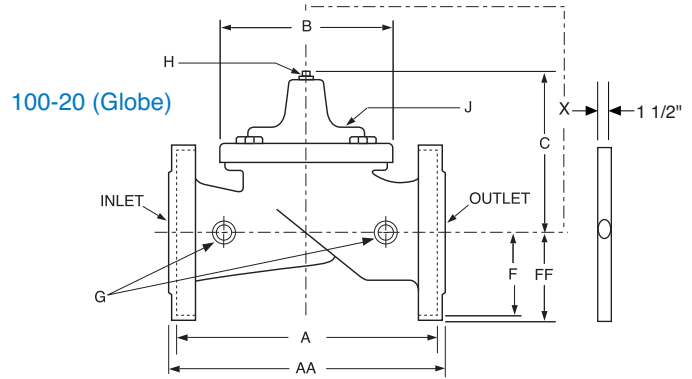

















































Materials

Component	Standard Material Combinations		
Body & Cover	Ductile Iron	Cast Steel	Bronze
Available Sizes	3" - 48"	3" - 16"	3" - 16"
Disc Retainer & Diaphragm Washer	Cast Iron	Cast Steel	Bronze
Trim: Disc Guide, Seat & Cover Bearing	Bronze is Standard Stainless Steel is Optional		
Disc	Buna-N® Rubber		
Diaphragm	Nylon Reinforced Buna-N® Rubber		
Stem, Nut & Spring	Stainless Steel		

For material options not listed, consult factory.
Cla-Val manufactures valves in more than 50 different alloys.

Model 640-01 Dimensions (In Inches)

Valve Size (Inches)	3	4	6	8	10	12	14	16	18	20	24	30
A 150 ANSI	10.25	13.88	17.75	21.38	26.00	30.00	34.25	35.00	42.12	48.00	48.00	63.25
AA 300 ANSI	11.00	14.50	18.62	22.38	27.38	31.50	—	36.62	43.63	49.62	49.75	—
B Dia.	6.62	9.12	11.50	15.75	20.00	23.62	28.00	28.00	35.44	35.44	35.44	53.19
C Max.	7.00	8.62	11.62	15.00	17.88	21.00	20.88	25.75	25.00	31.00	31.00	43.94
D 150 ANSI	—	6.94	8.88	10.69	—	—	—	—	—	—	—	—
DD 300 ANSI	—	7.25	9.38	11.19	—	—	—	—	—	—	—	—
E 150 ANSI	—	5.50	6.75	7.25	—	—	—	—	—	—	—	—
EE 300 ANSI	—	5.81	7.25	7.75	—	—	—	—	—	—	—	—
F 150 ANSI	3.75	4.50	5.50	6.75	8.00	9.50	11.00	11.75	15.88	14.56	17.00	19.88
FF 300 ANSI	4.12	5.00	6.25	7.50	8.75	10.25	—	12.75	15.88	16.06	19.00	—
H NPT Body Tapping	3/8	1/2	3/4	3/4	1	1	1	1	1	1	1	1
J NPT Cover Center Plug	1/2	1/2	3/4	3/4	1	1	1 1/4	1 1/4	2	2	2	2
K NPT Cover Tapping	3/8	1/2	3/4	3/4	1	1	1	1	1	1	1	1
Valve Stem Internal Thread UNF	10-32	1/4-28	1/4-28	3/8-24	3/8-24	3/8-24	3/8-24	3/8-24	1/2-20	1/2-20	1/2-20	3/4-16
Stem Travel	0.6	0.8	1.1	1.7	2.3	2.8	3.4	3.4	3.4	4.5	4.5	6.5
Approx. Ship Wt. Lbs.	45	85	195	330	625	900	1250	1380	1500	2551	2733	6500
X Pilot System	13.00	15.00	27.00	30.00	33.00	36.00	36.00	41.00	40.00	46.00	55.00	68.00
Y Pilot System	10.00	11.00	18.00	20.00	22.00	24.00	26.00	26.00	30.00	30.00	30.00	39.00
Z Pilot System	10.00	11.00	18.00	20.00	22.00	24.00	26.00	26.00	30.00	30.00	30.00	39.00

Valve Selection		These Symbols  and  Indicate Available Sizes																	
		Inches	1¼	1½	2	2½	3	4	6	8	10	12	14	16	18	20	24	30	36
		mm	32	40	50	65	80	100	150	200	250	300	350	400	450	500	600	750	900
End Detail		Threaded	Threaded & Flanged						Flanged										
Model 40-01	Basic Valve 100-01	Globe																	
		Angle																	
	Suggested Flow (gpm)	Max. Continuous		125	210	300	460	800	1800	3100	4900	7000	8400	11000			25000		50000
		Max. Intermittent		160	260	370	580	990	2250	3900	6150	8720	10540	13700			31300		62500
		Min. Continuous		10	15	20	30	50	115	200	300	400	500	650			1750		2900
	Suggested Flow (Liters/Sec)	Max. Continuous		8	13	19	29	50	113	195	309	441	529	693			1575		3150
		Max. Intermittent		10.1	16.4	23	37	62	142	246	387	549	664	863			1972		3940
		Min. Continuous		.6	.9	1.3	1.9	3.2	7.2	13	19	25	32	41			110		180
	Model 640-01	Basic Valve 100-20	Globe																
Angle																			
Suggested Flow (gpm)		Max. Continuous					260	580	1025	2300	4100	6400	9230	9230	16500	16500	16500	28000	
		Min. Continuous					15	30	50	115	200	300	500	500	900	900	900	1850	
Suggested Flow (Liters/Sec)		Max. Continuous					16	37	65	145	258	403	581	581	1040	1040	1040	1764	
		Min. Continuous					.9	1.9	3.2	7.2	13	19	32	32	57	57	57	117	

640-01 is the reduced internal port size version of the 40-01.

For 100-01 basic valves, suggested flow calculations were based on flow through Schedule 40 Pipe. Maximum continuous flow is approx. 20 ft/sec (6.1 meters/sec) & maximum intermittent is approx. 25 ft/sec (7.6 meters/sec) and minimum continuous flow is approx. 1 ft/sec (.3 meters/sec). For 100-20 basic valves, suggested flow calculations were based on flow through the valve seat. Approx. 26 ft/sec (7.9 meters/sec) was used for maximum continuous flow & 1 ft/sec (.3 meters/sec) is used for minimum continuous flow. Maximum continuous flow through the valve seat for the 30" 100-20 is approx. 20 ft/sec (6.1 meters/sec).

**Flanged End Detail Only

Pilot System Specifications

Adjustment Range

Low flow equals one-fourth maximum flow.

Temperature Range

Water: to 180°F

Materials

Standard Pilot System Materials

Pilot Control: Bronze ASTM B62

Trim: Stainless Steel 303

Orifice Plate: Stainless Steel 303

Rubber: Buna-N® Synthetic

Rubber

Optional Pilot System Materials

Pilot systems are available with optional

Aluminum, Stainless Steel or Monel

materials at additional cost.

When Ordering, Please Specify

1. Catalog No. 40-01 or No. 640-01
2. Valve Size
3. Pattern - Globe or Angle
4. Pressure Class
5. Threaded or Flanged
6. Trim Material
7. Adjustment Range/Orifice Bore
8. Desired Options
9. When Vertically Installed

Note: Orifice plate assembly (X52E) may be attached to the main valve outlet flange, however, better control is obtained if it is located one to five pipe diameters downstream. Orifice plate sensing connection should be located in the pipeline on the side of the orifice plate assembly. The orifice plate assembly should not be mounted directly to a butterfly valve. See E-X52E Data Sheet for Orifice Bore adjustment range.



Distributed By:
M&M Control Service, INC.
Phone: 800-876-0036
Fax: 847-356-0747
Email: Sales@mmcontrol.com