

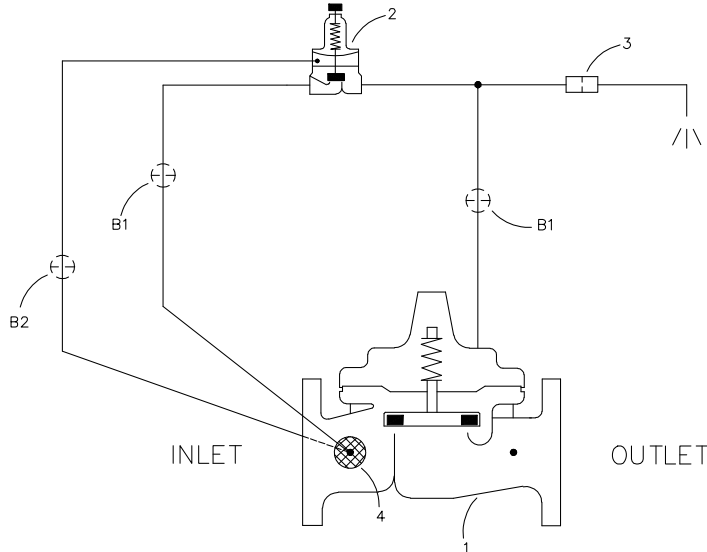

**50-33**  
 (Full Internal Port)  
 - MODEL -  
**650-33**  
 (Reduced Internal Port)

## Excess Pressure Safety Shut-Off Valve



- **Automatic Operation Adds Safety to Pressure Reducing Valve (PRV) Rigs**
- **Easy Adjustment and Maintenance**
- **Optional BMS Fail Signal**
- **Available with Automatic or Manual Reset**

The Cla-Val 50-33/650-33 Excess Pressure Safety Shut-Off Valve (XPSV) automatically protects the downstream distribution piping and fixtures from experiencing excess unsafe pressures in the event that outlet pressure of the high flow PRV rises above an acceptable level. Typically, the XPSV is set 10-15 psi higher than the PRV setpoint.

In operation, when the PRV discharge pressure is as set, the XPSV is fully open. When the PRV outlet pressure rises above normal, the XPSV will begin close to isolate the excess pressure from the downstream piping. Operation is completely automatic and may be easily field adjusted.

### Schematic Diagram

#### Item Description

- 1 Hytrol (Main Valve) Reverse Flow
- 2 CRL Pressure Relief Control
- 3 X58C Restriction Assembly
- 4 X46A Flow Clean Strainer

### Optional Features

#### Item Description

- B CK2 (Isolation Valve)
- P X141 Pressure Gauge
- V X101 Valve Position Indicator

### Application Overview

Water systems that serve critical fixtures and require uninterrupted water service should be designed with the added security of the Excess Pressure Safety Shut-Off Valve. Careful review of the system flow requirements, and need for PRV redundancy, should be considered when determining the optimum PRV Station design. When seeking the highest reliability for the PRV Station, careful consideration of the valve construction materials is important.

A Fail Switch Option provides contact closure for remote (BMS) indication of an event that requires operator attention. If the PRV Station is located in an area where an adequate drain is not available, a Dry Drain option should be considered. The hydraulic conditions must be taken into account when specifying the Model 50-33 Excess Pressure Safety Shut-Off Valve.

### Typical Application

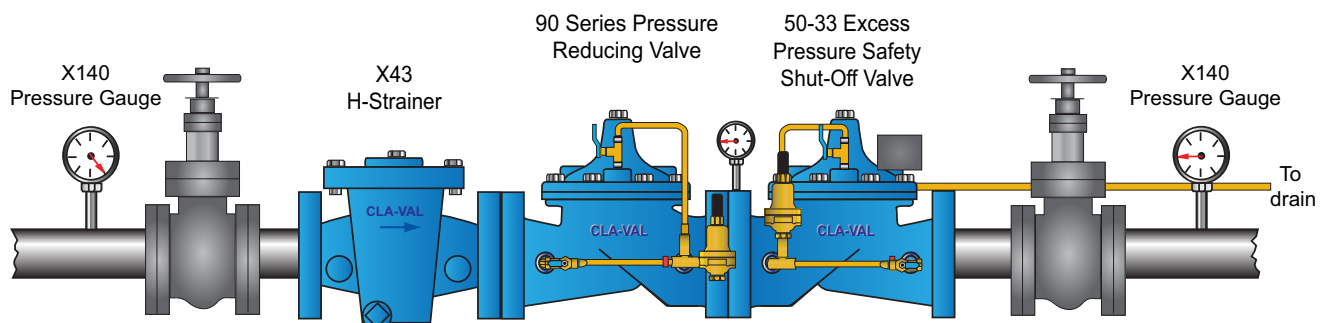

### Application Details

- Discharge to atmosphere or to contractor supplied drain piping
- Redundant design with parallel installation is suggested for commercial applications where uninterrupted service is required

Visit [www.mmcontrol.com](http://www.mmcontrol.com) for more information  
 Call 800.876.0036 for technical assistance

**Model 50-33** (Uses Basic Valve Model 100-01)

**Pressure Ratings** (Recommended Maximum Pressure - psi)

| Valve Body & Cover |              | Pressure Class  |           |           |           |              |
|--------------------|--------------|-----------------|-----------|-----------|-----------|--------------|
|                    |              | Flanged         |           | Grooved   | Threaded  |              |
| Grade              | Material     | ANSI Standards* | 150 Class | 300 Class | 300 Class | End‡ Details |
| ASTM A536          | Ductile Iron | B16.42          | 250       | 400       | 400       | 400          |
| ASTM A216-WCB      | Cast Steel   | B16.5           | 285       | 400       | 400       | 400          |
| ASTM B62           | Bronze       | B16.24          | 225       | 400       | 400       | 400          |

Note: \* ANSI standards are for flange dimensions only.  
 Flanged valves are available faced but not drilled.  
 ‡ End Details machined to ANSI B2.1 specifications.  
**Valves for higher pressure are available; consult factory for details**

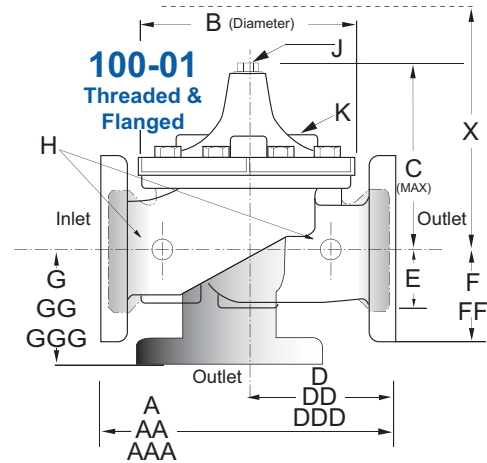

**Materials**

| Component                              | Standard Material Combinations                    |            |          |
|--|---|------------|----------|
| Body & Cover                           | Ductile Iron                                      | Cast Steel | Bronze   |
| Available Sizes                        | 1" - 36"  | 1" - 16"   | 1" - 16" |
| Disc Retainer & Diaphragm Washer       | Cast Iron   | Cast Steel | Bronze   |
| Trim: Disc Guide, Seat & Cover Bearing | Bronze is Standard<br>Stainless Steel is Optional |            |          |
| Disc                                   | Buna-N® Rubber                                    |            |          |
| Diaphragm                              | Nylon Reinforced Buna-N® Rubber                   |            |          |
| Stem, Nut & Spring                     | Stainless Steel                                   |            |          |

For material options not listed, consult factory.  
 Cla-Val manufactures valves in more than 50 different alloys.

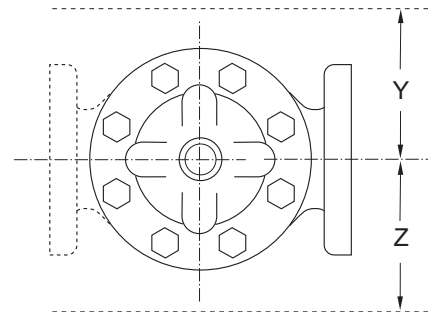

**Model 50-33 Dimensions** (In Inches)

| Valve Size (Inches)     | 1    | 1 1/4 | 1 1/2 | 2     | 2 1/2 | 3     | 4     | 6     |
|-------------------------|------|-------|-------|-------|-------|-------|-------|-------|
| A Threaded              | 7.25 | 7.25  | 7.25  | 9.38  | 11.00 | 12.50 | —     | —     |
| AA 150 ANSI             | —    | —     | 8.50  | 9.38  | 11.00 | 12.00 | 15.00 | 20.00 |
| AAA 300 ANSI            | —    | —     | 9.00  | 10.00 | 11.62 | 13.25 | 15.62 | 21.00 |
| AAAA Grooved End        | —    | —     | 8.50  | 9.00  | 11.00 | 12.50 | 15.00 | 20.00 |
| B Dia.                  | 5.62 | 5.62  | 5.62  | 6.62  | 8.00  | 9.12  | 11.50 | 15.75 |
| C Max.                  | 5.50 | 5.50  | 5.50  | 6.50  | 7.56  | 8.19  | 10.62 | 13.38 |
| CC Max. Grooved End     | —    | —     | 4.75  | 5.75  | 6.88  | 7.25  | 9.31  | 12.12 |
| D Threaded              | 3.25 | 3.25  | 3.25  | 4.75  | 5.50  | 6.25  | —     | —     |
| DD 150 ANSI             | —    | —     | 4.00  | 4.75  | 5.50  | 6.00  | 7.50  | 10.00 |
| DDD 300 ANSI            | —    | —     | 4.25  | 5.00  | 5.88  | 6.38  | 7.88  | 10.50 |
| DDDD Grooved End        | —    | —     | —     | 4.75  | —     | 6.00  | 7.50  | —     |
| E                       | 1.12 | 1.12  | 1.12  | 1.50  | 1.69  | 2.06  | 3.19  | 4.31  |
| EE Grooved End          | —    | —     | 2.00  | 2.50  | 2.88  | 3.12  | 4.25  | 6.00  |
| F 150 ANSI              | —    | —     | 2.50  | 3.00  | 3.50  | 3.75  | 4.50  | 5.50  |
| FF 300 ANSI             | —    | —     | 3.06  | 3.25  | 3.75  | 4.13  | 5.00  | 6.25  |
| G Threaded              | 1.88 | 1.88  | 1.88  | 3.25  | 4.00  | 4.50  | —     | —     |
| GG 150 ANSI             | —    | —     | 4.00  | 3.25  | 4.00  | 4.00  | 5.00  | 6.00  |
| GGG 300 ANSI            | —    | —     | 4.25  | 3.50  | 4.31  | 4.38  | 5.31  | 6.50  |
| GGGG Grooved End        | —    | —     | —     | 3.25  | —     | 4.25  | 5.00  | —     |
| H NPT Body Tapping      | .375 | .375  | .375  | .375  | .50   | .50   | .75   | .75   |
| J NPT Cover Center Plug | .25  | .25   | .25   | .50   | .50   | .50   | .75   | .75   |
| K NPT Cover Tapping     | .375 | .375  | .375  | .375  | .50   | .50   | .75   | .75   |
| Stem Travel             | 0.4  | 0.4   | 0.4   | 0.6   | 0.7   | 0.8   | 1.1   | 1.7   |
| Approx. Ship Wt. Lbs.   | 15   | 15    | 15    | 35    | 50    | 70    | 140   | 285   |
| X Pilot System          | 11   | 11    | 11    | 13    | 14    | 15    | 17    | 29    |
| Y Pilot System          | 9    | 9     | 9     | 9     | 10    | 11    | 12    | 20    |
| Z Pilot System          | 9    | 9     | 9     | 9     | 10    | 11    | 12    | 20    |

**Model 650-33** (Uses Basic Valve Model 100-20)

**Pressure Ratings** (Recommended Maximum Pressure - psi)

| Valve Body & Cover |              | Pressure Class  |           |           |
|--------------------|--------------|-----------------|-----------|-----------|
|                    |              | Flanged         |           |           |
| Grade              | Material     | ANSI Standards* | 150 Class | 300 Class |
| ASTM A536          | Ductile Iron | B16.42          | 250       | 400       |
| ASTM A216-WCB      | Cast Steel   | B16.5           | 285       | 400       |
| ASTM B62           | Bronze       | B16.24          | 225       | 400       |

Note: \* ANSI standards are for flange dimensions only.  
Flanged valves are available faced but not drilled.  
**Valves for higher pressure are available; consult factory for details**

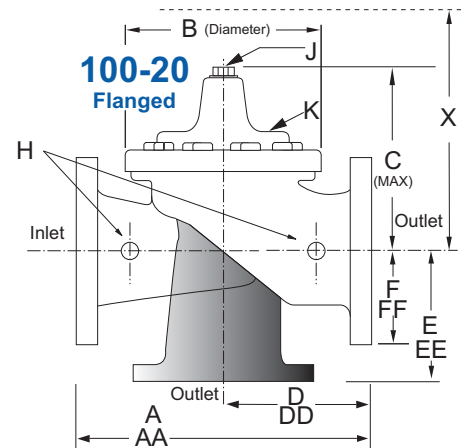

**Materials**

| Component                              | Standard Material Combinations                    |            |          |
|--|---|------------|----------|
| Body & Cover                           | Ductile Iron                                      | Cast Steel | Bronze   |
| Available Sizes                        | 3" - 48"  | 3" - 16"   | 3" - 16" |
| Disc Retainer & Diaphragm Washer       | Cast Iron   | Cast Steel | Bronze   |
| Trim: Disc Guide, Seat & Cover Bearing | Bronze is Standard<br>Stainless Steel is Optional |            |          |
| Disc                                   | Buna-N® Rubber                                    |            |          |
| Diaphragm                              | Nylon Reinforced Buna-N® Rubber                   |            |          |
| Stem, Nut & Spring                     | Stainless Steel                                   |            |          |

For material options not listed, consult factory.  
Cla-Val manufactures valves in more than 50 different alloys.

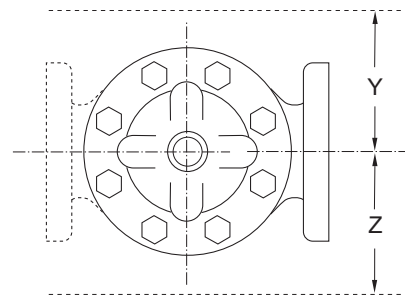

**Model 650-33 Dimensions** (In Inches)

| Valve Size (Inches)     | 3     | 4     | 6     |
|-------------------------|-------|-------|-------|
| A 150 ANSI              | 10.25 | 13.88 | 17.75 |
| AA 300 ANSI             | 11.00 | 14.50 | 18.62 |
| B Dia.                  | 6.62  | 9.12  | 11.50 |
| C Max.                  | 7.00  | 8.62  | 11.62 |
| D 150 ANSI              | —     | 6.94  | 8.88  |
| DD 300 ANSI             | —     | 7.25  | 9.38  |
| E 150 ANSI              | —     | 5.50  | 6.75  |
| EE 300 ANSI             | —     | 5.81  | 7.25  |
| F 150 ANSI              | 3.75  | 4.50  | 5.50  |
| FF 300 ANSI             | 4.12  | 5.00  | 6.25  |
| H NPT Body Tapping      | .375  | .50   | .75   |
| J NPT Cover Center Plug | .50   | .50   | .75   |
| K NPT Cover Tapping     | .375  | .50   | .75   |
| Stem Travel             | 0.6   | 0.8   | 1.1   |
| Approx. Ship Wt. Lbs.   | 45    | 85    | 195   |
| X Pilot System          | 13    | 15    | 27    |
| Y Pilot System          | 10    | 11    | 18    |
| Z Pilot System          | 10    | 11    | 18    |

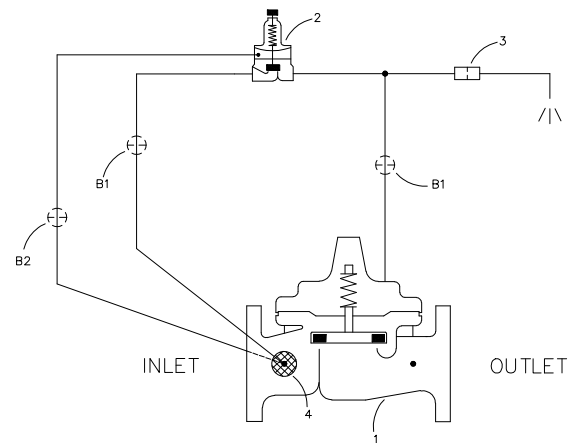

\*Consult Factory

## Valve Selection Guide

|                                 |            |      |      |           |           |           |           |           |           |
|---------------------------------|------------|------|------|-----------|-----------|-----------|-----------|-----------|-----------|
| <b>50-33</b><br>Valve Selection | Inches     | 1    | 1¼   | 1½        | 2         | 2½        | 3         | 4         | 6         |
|                                 | mm         | 25   | 32   | 40        | 50        | 65        | 80        | 100       | 150       |
| Basic Valve<br>100-01           | Pattern    | G, A | G, A | G, A      | G, A      | G, A      | G, A      | G, A      | G, A      |
|                                 | End Detail | T    | T    | T, F, GR* | T, F, GR* | T, F, GR* | T, F, GR* | T, F, GR* | T, F, GR* |
| Suggested Flow (gpm)            | Maximum    | 55   | 93   | 125       | 210       | 300       | 460       | 800       | 1800      |
| Suggested Flow (Liters/Sec)     | Maximum    | 3.5  | 6    | 8         | 13        | 19        | 29        | 50        | 113       |

\* Note: Grooved end valves are available in globe pattern only.

|                                  |            |     |      |      |
|----------------------------------|------------|-----|------|------|
| <b>650-33</b><br>Valve Selection | Inches     | 3   | 4    | 6    |
|                                  | mm         | 80  | 100  | 150  |
| Basic Valve<br>100-20            | Pattern    | G   | G, A | G, A |
|                                  | End Detail | F   | F    | F    |
| Suggested Flow (gpm)             | Maximum    | 260 | 580  | 1025 |
| Suggested Flow (Liters/Sec)      | Maximum    | 16  | 37   | 65   |

### Notes

#### Full Port Valves:

- 100-01 Pattern: Globe, Angle
- End Connections:
  - Flanged
  - Threaded
  - Grooved
- Pressure Classes: 150 and 300

#### Reduced Port Valves:

- 100-20 Series is the reduced internal port size version of the 100-01 Series
- 100-20 Pattern: Globe, Angle
- End Connections:
  - Flanged
- Pressure Classes: 150 and 300

## Pilot System Specifications

### Adjustment Ranges

0 to 75 psi Max.  
 20 to 105 psi  
 20 to 200 psi \*  
 100 to 300 psi

\*Supplied unless otherwise specified.  
 Other ranges available, please consult factory.

### Temperature Range

Water: to 180°F

### Materials

#### Standard Pilot System Materials

Pilot Control: Bronze ASTM B62  
 Trim: Stainless Steel Type 303  
 Rubber: Buna-N® Synthetic Rubber  
 Tubing & Fitting: Copper and Bronze

#### Optional Pilot System Materials

Pilot Systems are available with optional Aluminum, Stainless Steel or Monel materials.

## When Ordering, Please Specify

1. Catalog No. 50-33 or No. 650-33
2. Valve Size
3. Pattern - Globe or Angle
4. Pressure Class
5. Threaded or Flanged
6. Trim Material
7. Adjustment Range
8. Desired Options
9. When Vertically Installed



**CLA-VAL**

Distributed By:  
 M&M Control Service, Inc.  
 Phone: 800-876-0036  
 Fax: 847-356-0747  
 Email: sales@mmcontrol.com

Represented By:

**CLA-VAL**™

E-50-33/650-33 (R-07/2013)