

# *Dwyer*<sup>®</sup>

**Manufacturing Excellence Since 1931**

pressure | temperature | test & data | air quality

flow | level | process control | valves

# 2020

Distributed by: <https://www.mmcontrol.com/Dwyer.php>



The **trusted leader** in manufacturing innovative instrumentation solutions for the **worldwide** HVAC and process automation markets

## CUSTOMER SATISFACTION

Meet and exceed customer and market expectations

## INNOVATIVE

Sustained R&D and product development

## COMPETITIVE

Highly automated and flexible manufacturing capabilities

## TRUSTED

High-quality, reliable, and readily available products and solutions

## GLOBAL SUPPORT

Global sales and marketing presence

### ESTABLISHED DWYER BRANDS





# DWYER AROUND THE GLOBE

---



## CONTACT INFORMATION

---

Dwyer has local distributors in over 79 countries.

Distributed by: M&M Control Service, Inc.  
<https://www.mmcontrol.com/Dwyer.php>  
800-876-0036 847-356-0566  
Fax: 847-356-0747

# ABOUT US

Since the company was founded in 1931, customers have come to recognize Dwyer Instruments, Inc. to stand for quality, reliability, and readily available competitively priced products. As a leading manufacturer in the controls and instrumentation industry, we continue to grow and serve major markets including, but not limited to: HVAC, chemical, agriculture, food, oil and gas, water, wastewater, powder and bulk, and pollution control.

Dwyer holds over 650 technical patents and that number grows every year. We are an enthusiastic group of people headquartered in Michigan City, Indiana, with satellite locations around the globe. We take great pride in the intellect and integrity of our employees, who are passionate about the work we do, the products we develop, and the industries we serve.

## MANUFACTURING EXCELLENCE

At Dwyer, it all starts with commitment to meeting the needs of our customers. We strive to make dependable, easy-to-use products.

With nearly 90 years of manufacturing expertise, we stand behind our high quality products. Dwyer products are trusted in applications all over the world in nearly every industry.



## MANUFACTURING & DESIGN CENTER LOCATIONS



# HVAC TESTING

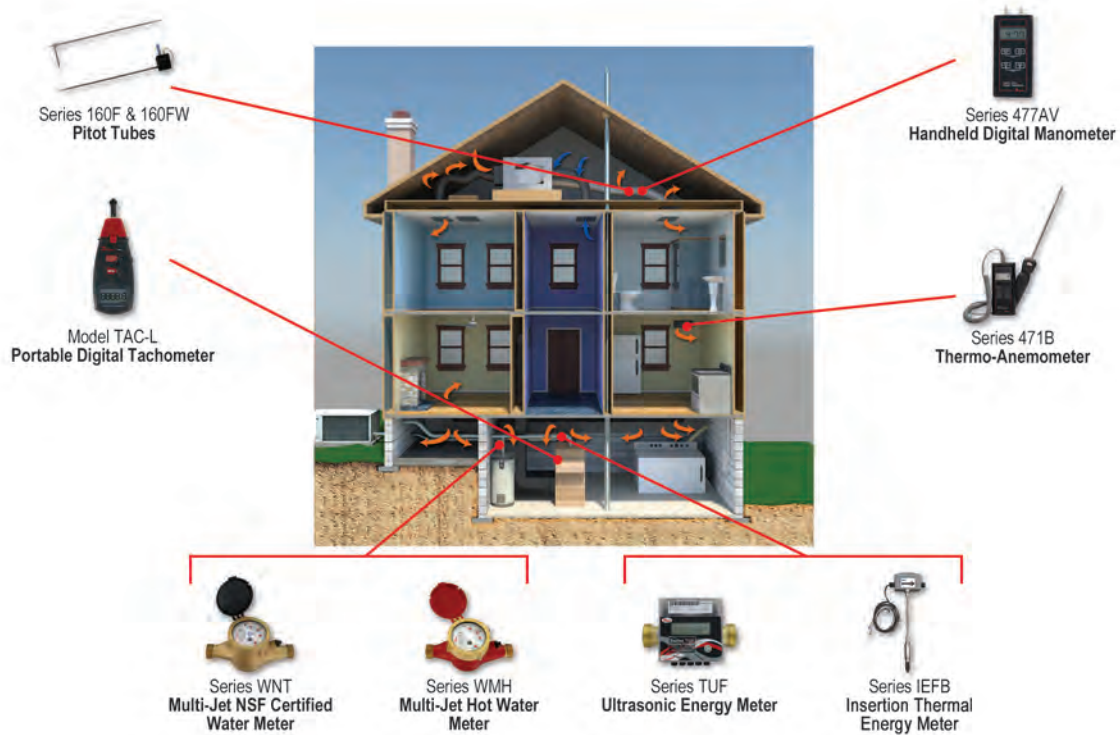

# AIR HANDLER

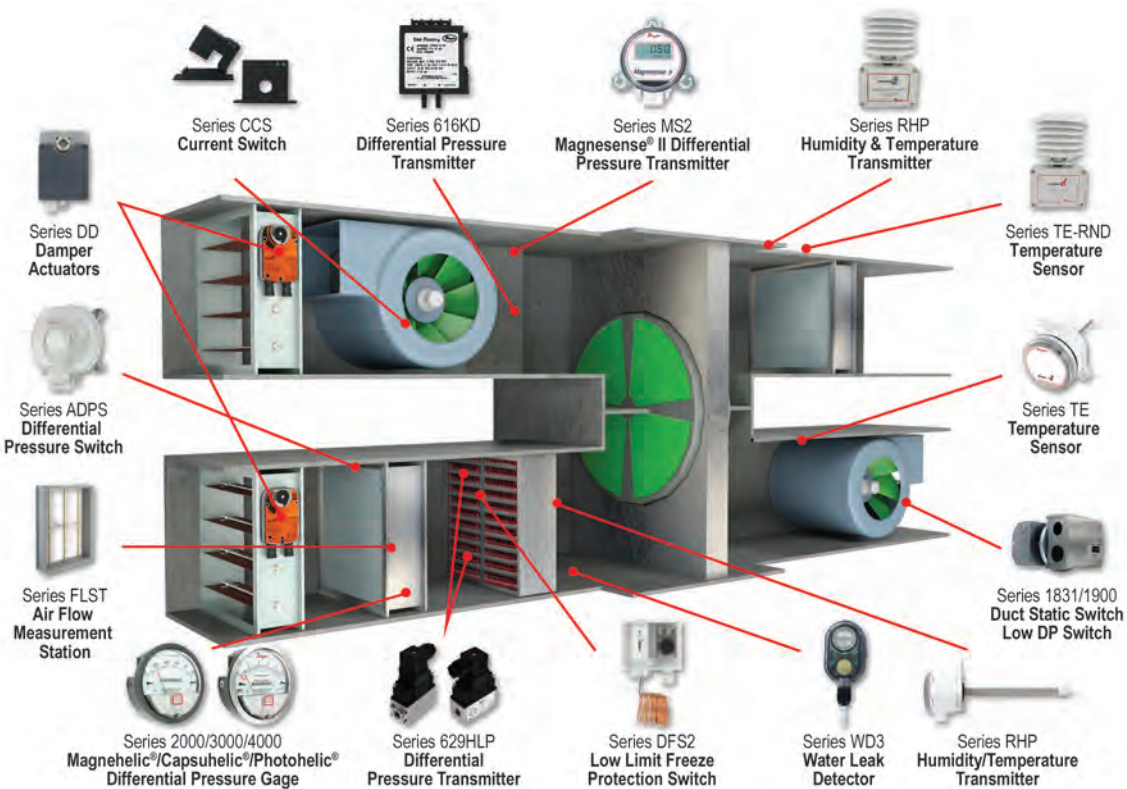



## TERMINAL UNIT

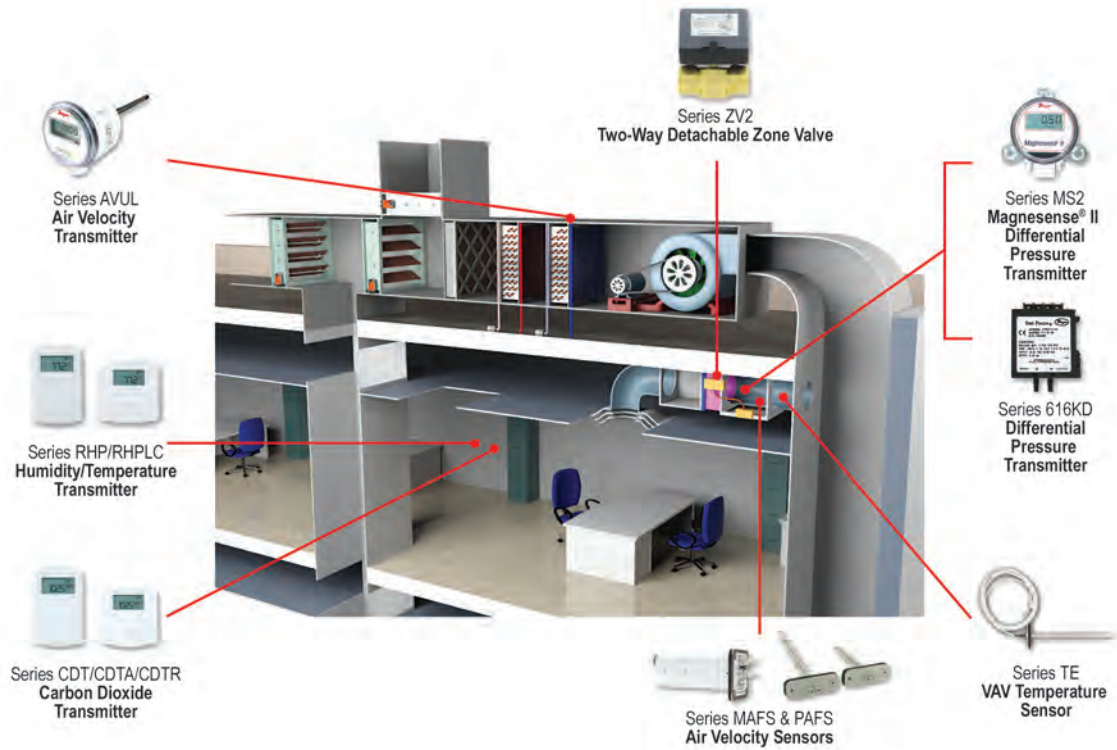

## CHILLER PLANT

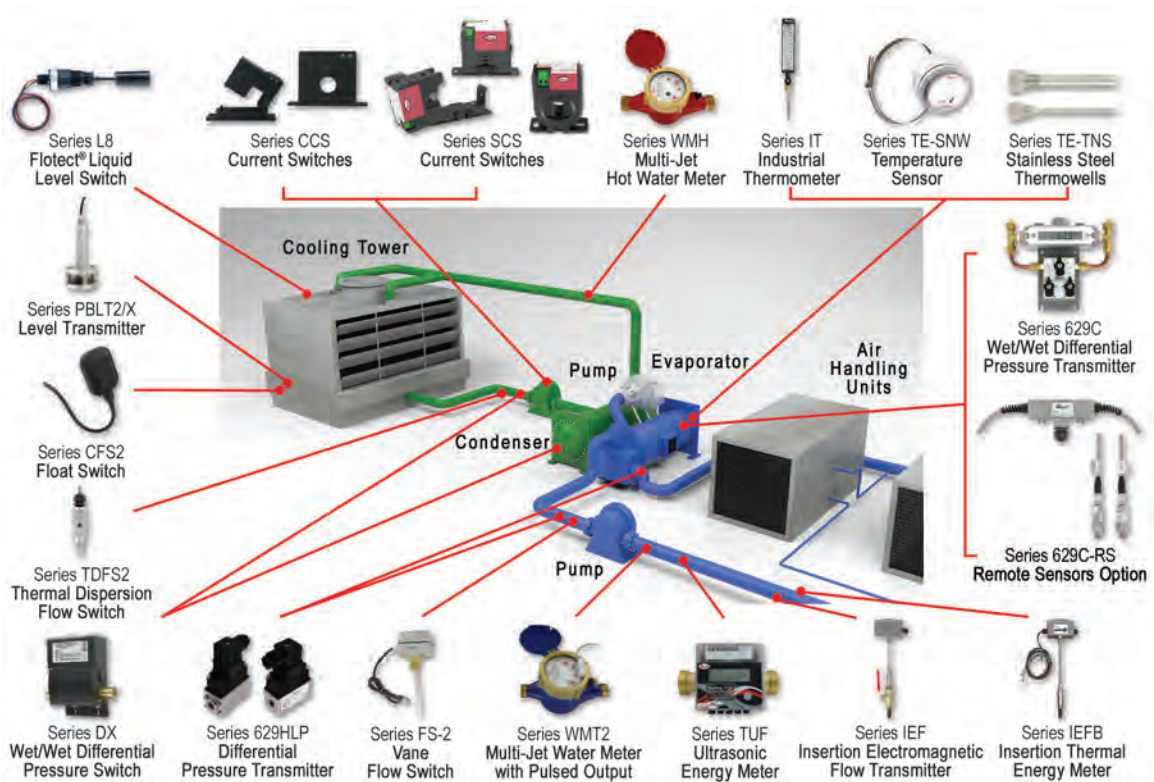

# WASTEWATER

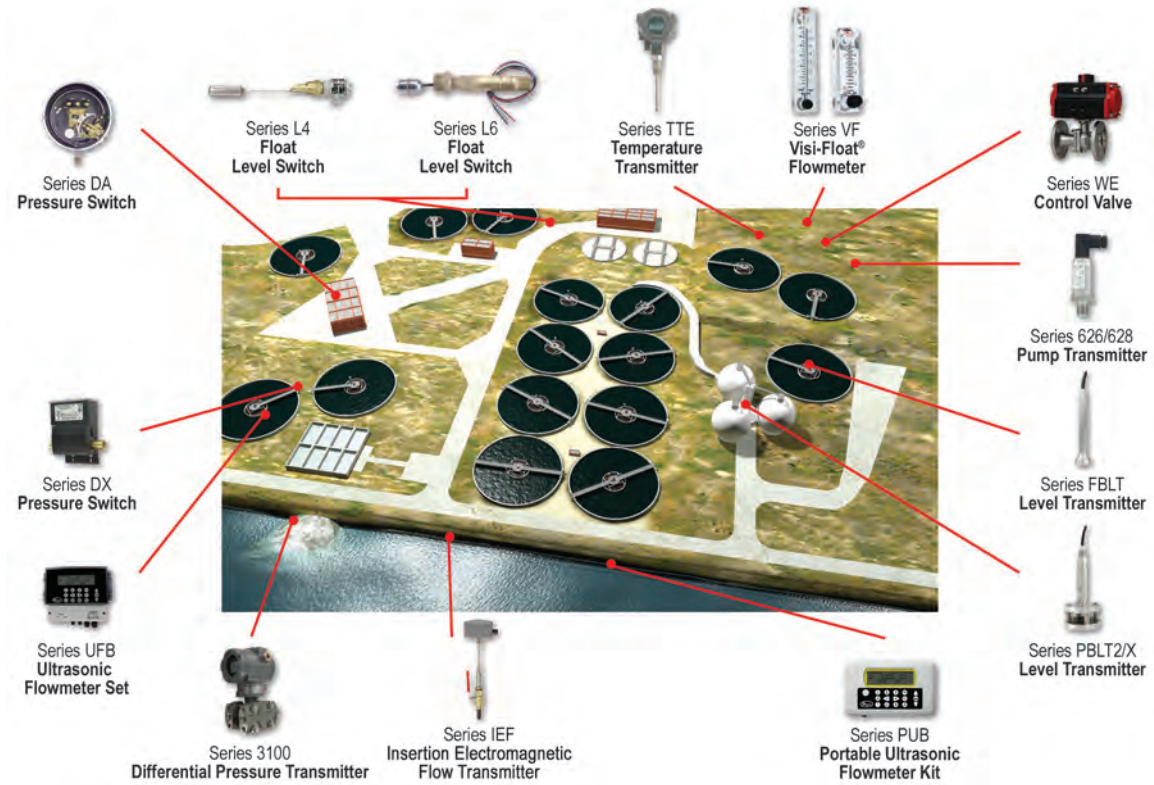

# DUST COLLECTOR

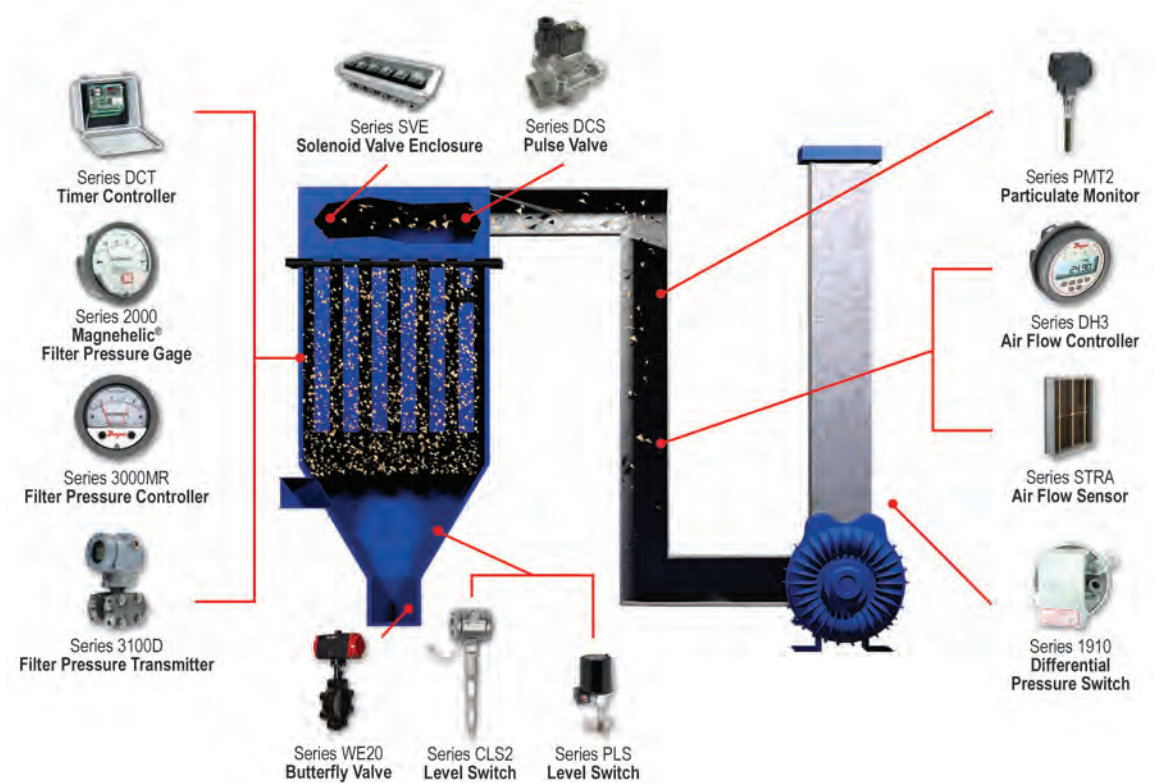

PRODUCT APPLICATIONS



## MIDSTREAM REFINERY/CHEM PLANT

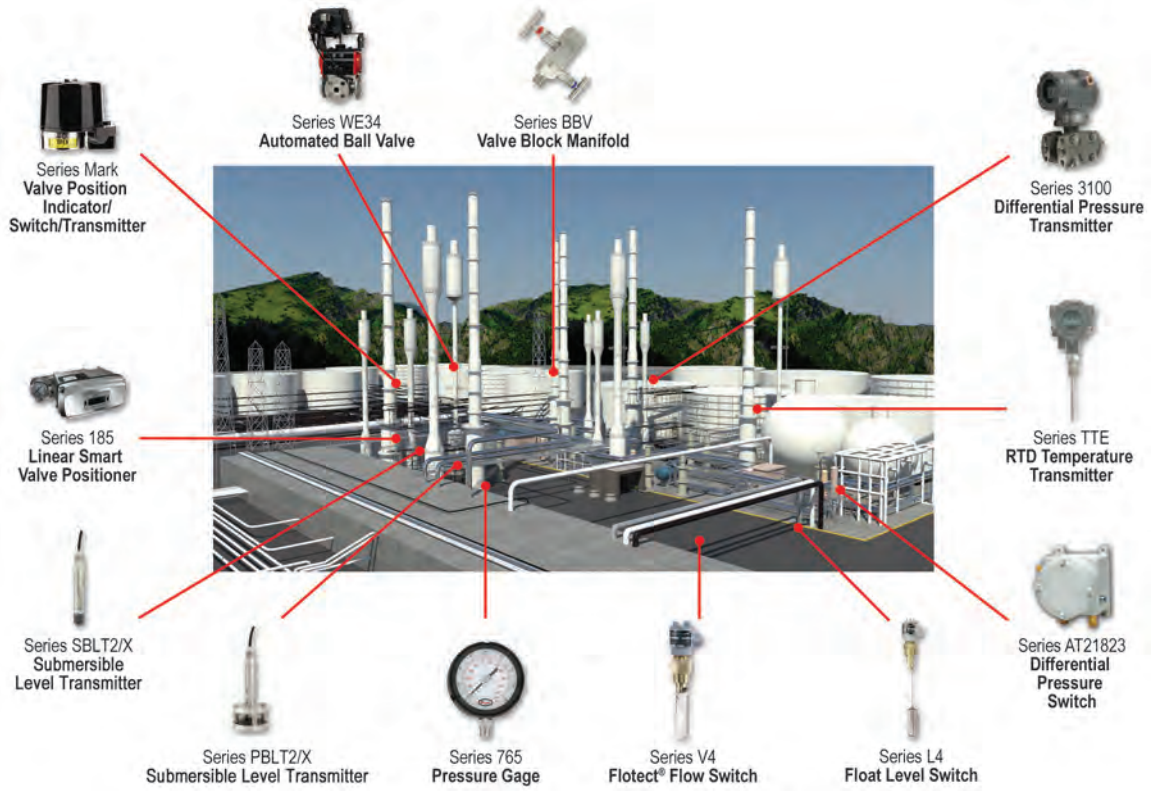

## BUILDING BALANCING

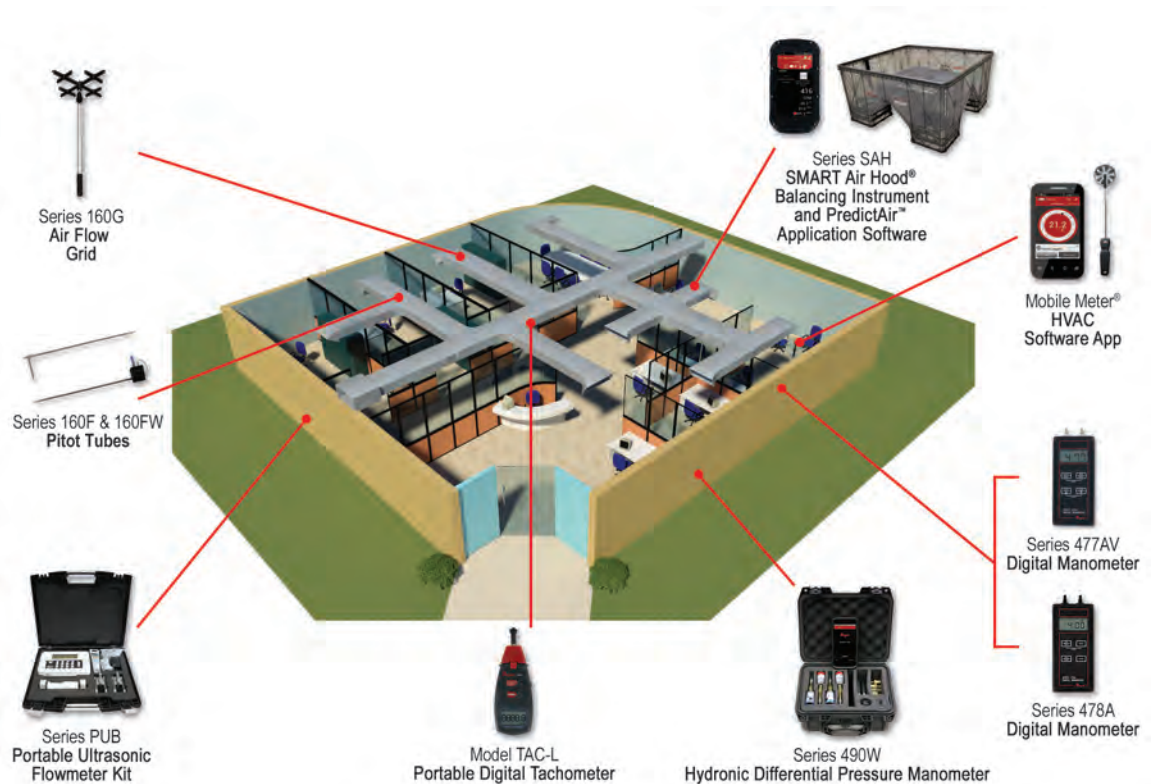

# POULTRY/HOG/GREENHOUSES

Series WMT2 Water Meter

Model 485B Thermo-Hygrometer

Series RHP Humidity/Temperature Transmitter

Series CDWP Carbon Dioxide Transmitter

Series O-4 Temperature Sensor

Series A3000 Photohelic® Pressure Switch/Gage

Series TSW Weather-proof Temperature Switch

Series F6 Level Switch

Series WD3 Water Leak Detector

Series WPT Multi-Jet Water Meter

# CLEAN ROOM

Series 605 Magnehelic® Differential Pressure Indicating Transmitter

Series ADPS Differential Pressure Switch

Series RHP-M Humidity/Temperature Transmitter

Series 641 Air Velocity Transmitter

Series RSM Room Status Monitor

Series TE-E/N Wall Mount Temperature Sensor

Series SPPM2 Graphical User Interface Panel Meter

Model 670 Fume Hood Monitor

Series TE-WSS Stainless Steel Wall Plate Temperature Sensor

Series 4B-33-986/U Temperature/Process Controller

Series 2000 Magnehelic® Differential Pressure Gage



## CONTAINMENT CHAMBER/BOX

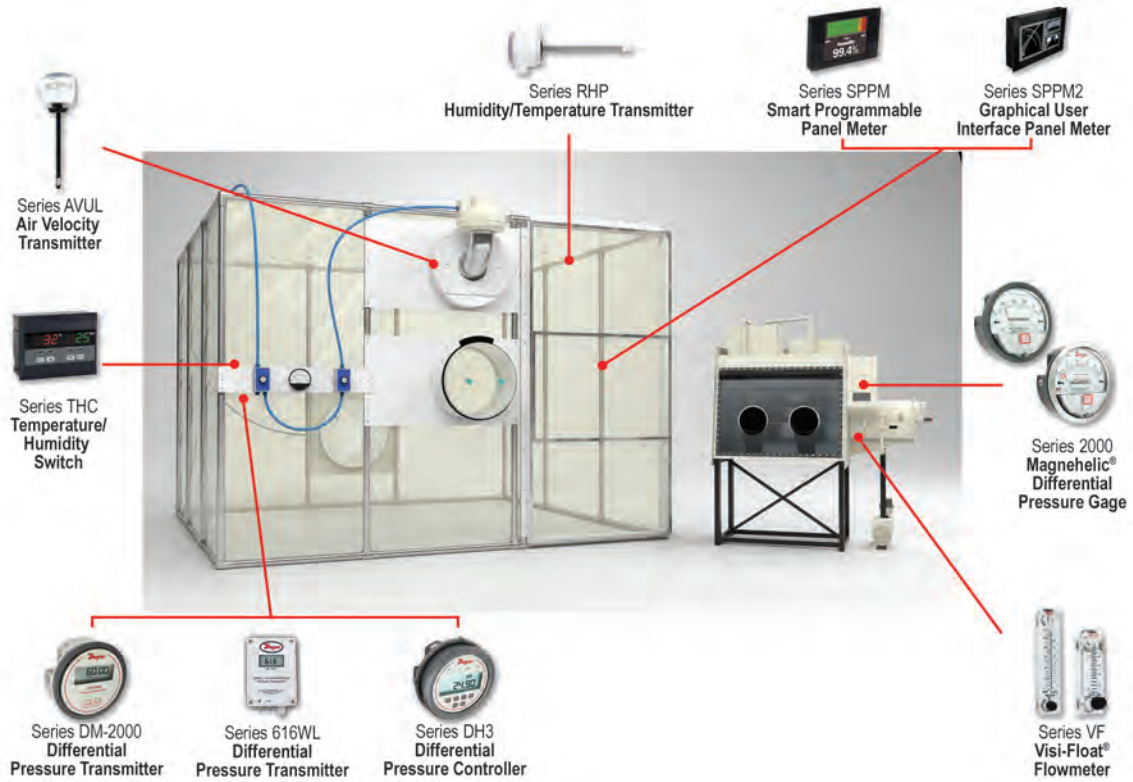

## CLEAN WATER

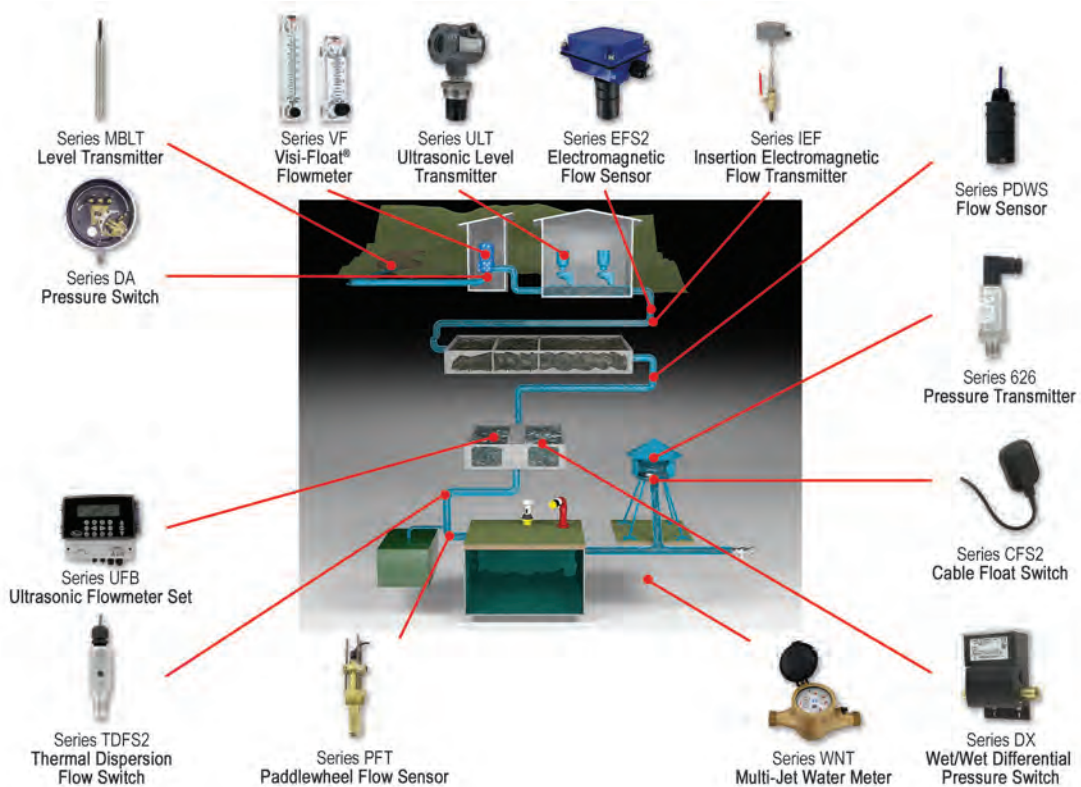

## PUMP SKID

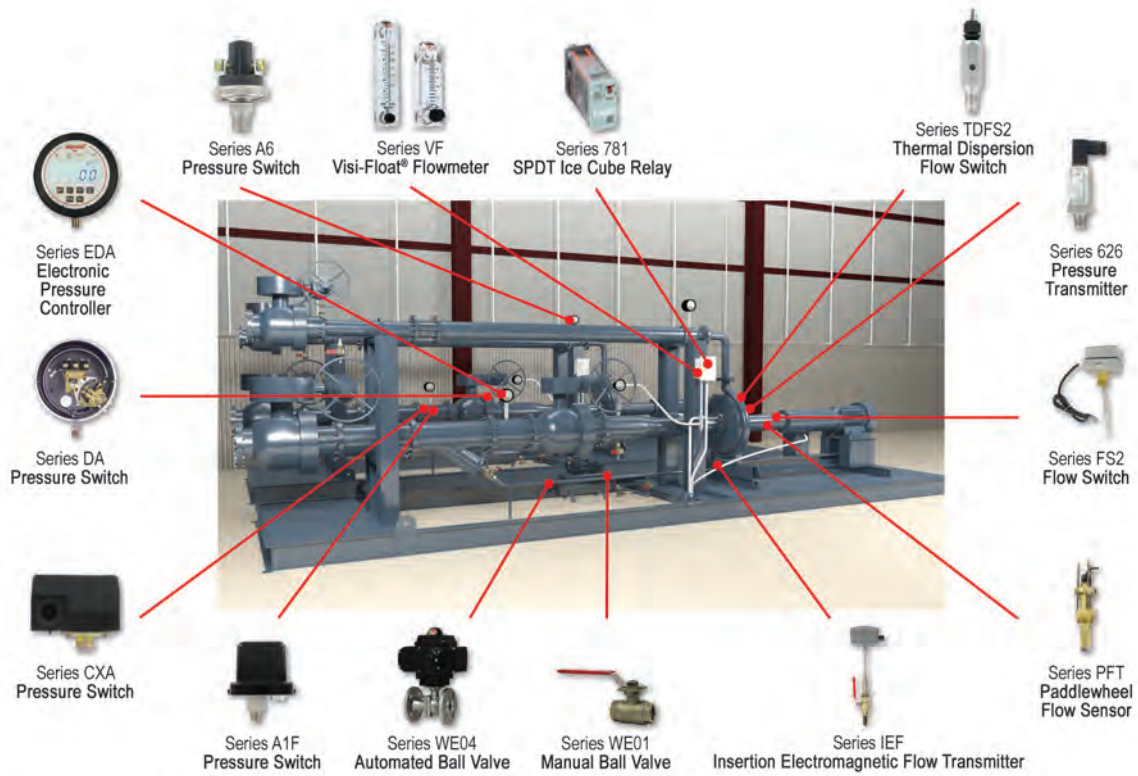

## IRRIGATION

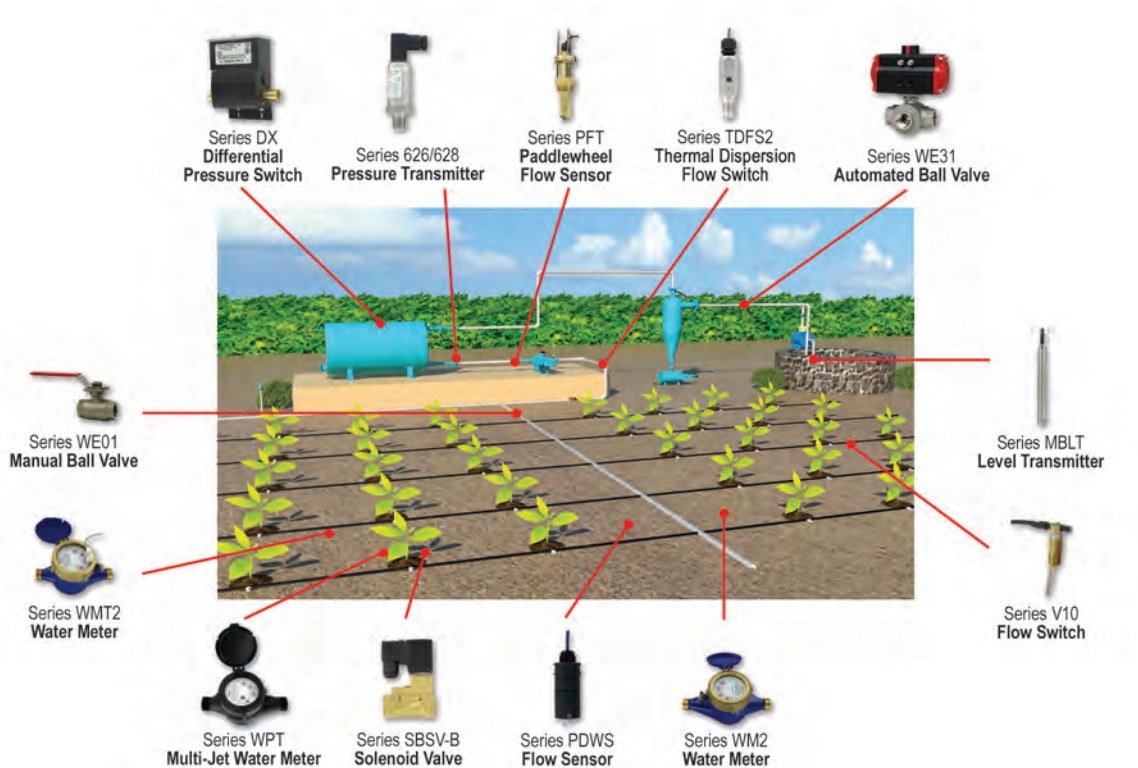

# KEY MARKETS

---



## HVAC

- Building Automation
- Test Equipment
- Controlled Environments
- Original Equipment  
(Chillers, Boilers, Air Handlers, Cooling Towers)
- Valve Automation

## PROCESS AUTOMATION

- Water and Wastewater
- Pharmaceutical
- Agriculture and Livestock
- Powder and Bulk
- Industrial Process
- Mining and Heavy Earth Moving
- Oil, Gas and Petrochemical
- Power
- Valve Automation

# INNOVATION AWARDS

---



Wireless Hydronic Balancing Kit  
Series 490W



*The ACHR News* is the leading trade magazine in the heating, ventilating, air conditioning, and refrigeration industries.

### GOLD

- HVAC Mobile Meter® Software Test Instrument App
- PredictAir™ Application Software
- Air Velocity Transmitter | **Series AVUL**

### SILVER

- Universal Handheld Test Instrument | **Model UHH2**
- Wireless Hydronic Balancing Kit | **Series 490W**
- Hydronic Application Software

### BRONZE

- SMART Air Hood® Balancing Instrument | **Series SAH**
- Hydronic Differential Pressure Manometer | **Series 490A**
- Insertion Electromagnetic Flow Transmitter | **Series IEF**



**PRESSURE** 1-110

- 1 Table of Contents
- 2-15 Selection Guides
- 16-17 Typical Applications
- 18-19 Pressure Sensor Accuracy
- 20-110 Product Pages

**PROCESS CONTROL** 341-376

- 341 Table of Contents
- 342-345 Selection Guides
- 346-347 Typical Applications
- 348-376 Product Pages

**TEMPERATURE** 111-150

- 111 Table of Contents
- 112-113 Selection Guides
- 114-115 Typical Applications
- 116-150 Product Pages

**VALVES** 377-448

- 377 Table of Contents
- 378-381 Selection Guides
- 382 Typical Applications
- 383 Technical Information
- 384-448 Product Pages

**TEST & DATA** 151-204

- 151 Table of Contents
- 152-155 Selection Guides
- 156-157 Typical Applications
- 158-163 HVAC Measurement Guide
- 164-204 Product Pages

**ACCESSORIES** 449-457

- 449 Table of Contents
- 450-457 Product Pages

**AIR QUALITY** 205-234

- 205 Table of Contents
- 206-207 Selection Guides
- 208-209 Typical Applications
- 210-234 Product Pages

**TECH GUIDE** 458-463

- 458-459 Glossary
- 460-462 Reference Tables
- 463 Trademark Acknowledgments

**FLOW** 235-298

- 235 Table of Contents
- 236-241 Selection Guides
- 242-244 Typical Applications
- 245 Technical Information
- 246-298 Product Pages

**INDEX** 464-476

- 464-468 Index - By Product
- 469-476 Index - By Category

**LEVEL** 299-340

- 299 Table of Contents
- 300-303 Selection Guides
- 304-305 Typical Applications
- 306-340 Product Pages

# RECENT INNOVATIONS

---



## DIFFERENTIAL PRESSURE TRANSMITTER - LOW RANGES SERIES 616KD-LR

- Wide selection of ranges down to 0.1 in w.c. and accuracies cover numerous applications minimizing components and standardizing on design
- Simple calibration push-buttons to set zero and span, saving time installing and maintaining over the service life
- Cost effective and compact device suitable for OEM applications where space, simplicity, and value are key

PAGE 59

---



## WET/WET DIFFERENTIAL PRESSURE TRANSMITTER - WITH REMOTE SENSORS SERIES 629C-RS

- Same benefits as the 629C Wet/Wet Differential Pressure Transmitter with the added convenience of using remote pressure sensors
- Available with standard cable and armored cable versions with 10 or 20 feet shielded cable
- Remote sensors option reduces installation cost
- Sensors convert pressure changes into a standard 4-20 mA output signal or field selectable voltage

PAGE 76

---



## DIFFERENTIAL PRESSURE TRANSMITTER SERIES 629HLP

- Measurement of small pressure differences of high-static line pressures
- $\pm 1\%$  accuracy through the entire operating temperature range from  $-10$  to  $60^\circ\text{C}$  ( $14$  to  $122^\circ\text{F}$ )
- For measuring over-pressure, under-pressure, and differential pressure
- 4 different ranges, up to 6 bars

PAGE 77

---



## WIRELESS HYDRONIC DIFFERENTIAL PRESSURE MANOMETER SERIES 490W

- Familiar ergonomic mobile device interface
- Full comprehensive kit for direct to job site capability on almost any application or hydronic valve
- Flow conversion capability built into the app minimizes steps in the balancing process
- Wide ranges and high resolution. Even at the 500 psid range, technicians can see readings

PAGE 172

---



## AVERAGING AIR FLOW GRID SERIES 160G

- New lightweight pole for longer periods of use with larger pole diameter for ergonomics
- Up to 48" (122 cm) of reach
- 16 sensing points provides an accurate average flow

PAGE 189

---

# RECENT INNOVATIONS

---



## METAL AVERAGING FLOW SENSOR SERIES MAFS

- Blade design limits disruption of air stream
- Configurable in inch or millimeter lengths up to 78 inches or 2000 mm
- Lightweight aluminum construction with flange mounting for rectangular or square ducts

PAGE 215

---



## WALL MOUNT HUMIDITY/TEMPERATURE TRANSMITTER SERIES RHPLC

- 2 or 3% accuracy models available
- Humidity only or temperature and humidity combo
- Wide selection of passive thermistor or RTD temperature sensors

PAGE 223

---



## CARBON DIOXIDE TRANSMITTER SERIES CDWP

- Single beam dual wavelength NDIR CO2 sensor automatically corrects for aging effects
- Durable and rugged aluminum housing designed to withstand 168 hour salt spray test
- Ranges include 2,000, 5,000, and 10,000 ppm allowing for use in animal husbandry as well as mechanical rooms utilizing CO2 based refrigerants

PAGE 227

---



## CARBON MONOXIDE TRANSMITTERS SERIES CMT200/CMT200-R

- Field replaceable sensor scaled at 0-200 PPM
- Round or rectangular housing options
- Field selectable current or voltage output signal

PAGE 233

---



## CARBON MONOXIDE TRANSMITTER AND SWITCH SERIES CMS300

- Field selectable current or voltage analog outputs
- Integral SPDT relay contact for low or high alarm
- Jumper selectable alarm set points of 25, 60, or 150 ppm

PAGE 233

---

# RECENT INNOVATIONS

---



## INSERTION THERMAL ENERGY METER SERIES IEFB

- Field configurable
- Integral or remote display for ultimate flexibility
- Complies with high accuracy requirements of EN 1434-1, ASTM E3137, CSA C900.1-13 for accurate heat measurement

PAGES 292-293

---



## REMOTE DISPLAY FOR SERIES IEF AND IEFB SERIES A-IEF

- Use to set up the IEF/IEFB and adjust the settings or indicate remotely
- Varying cable lengths of up to 100 ft (30 m) allows for flexible installation on a wall or pipe mount
- Easy to install and wire in the field

PAGE 293

---



## INSERTION ELECTROMAGNETIC FLOW TRANSMITTER SERIES IEF

- Field configurable
- Integral or remote displays allow for ultimate flexibility
- Multiple display configurations with a single unit



PAGE 294

---



## INSERTION ELECTROMAGNETIC FLOW TRANSMITTER KIT A-IEF-KIT

- Accessory setup kit
- Ensures exact installation application for the Series IEF
- Includes set up display, thickness gage, measuring tape and universal power adapter

PAGE 294

---



## ULTRASONIC ENERGY METERS SERIES TUF

- Manufactured to comply with EN1434-1 requirements
- Compact energy monitoring
- BACnet or Modbus® communication outputs

PAGE 295

---

Modbus® is a registered trademark of Schneider Automation, Inc.



**SELECTION GUIDE**  
pages 2-15

**TYPICAL APPLICATIONS**  
pages 16-17

**PRESSURE SENSOR ACCURACY**  
pages 18-19

  
**Differential Pressure Gages**  
pages 20-27, 31-33

  
**Manometers, Stationary**  
pages 28-30

  
**Differential Pressure Gages/Switches, Transmitters**  
pages 34-37

  
**Differential Pressure Gages/Switches, Dial**  
pages 38-44

  
**Differential Pressure Switches**  
pages 45-57

  
**Differential Pressure Transmitters, Air & Gas**  
pages 58-69

  
**Differential Pressure Transmitters, Liquid & Gas**  
pages 70-80

  
**Single Pressure Gages, Dial**  
pages 81-83

  
**Single Pressure Gages, Digital**  
pages 84-86

  
**Single Pressure Gages/Switches/Transmitters, Digital**  
pages 87-89

  
**Single Pressure Switches**  
pages 90-98

  
**Single Pressure Transmitters**  
pages 98-110

## FEATURED PRODUCTS

### DIFFERENTIAL PRESSURE TRANSMITTER SERIES 629HLP | page 77



- Rugged, versatile, high accuracy device
- Compact, lightweight, capable to be installed in any arrangement making installation very simple



### INDUSTRIAL PRESSURE TRANSMITTER SERIES 626 & 628 | pages 102-103



- High precision transmitter ensures stability and control to meet the needs of the most demanding applications
- Wide selection of models, ranges, accuracy, connections, and outputs to meet exacting pressure measurement specifications





# DIFFERENTIAL PRESSURE

## Pressure Gages

			
<b>SERIES</b>	<b>2000</b> - pages 20-21	<b>DM-1000</b> - page 25	<b>2-5000</b> - pages 26-27
<b>Ranges</b>	-0.05 to 0.2 in w.c. (-10 to 50 Pa) up to 0 to 30 psi (0 to 30 kPa)	0.25 to 100 in w.c. (60 Pa to 24.88 kPa) (Bi-directional ranges available)	0.5 in w.c. to 5 psi (125 Pa to 3 kPa)
<b>Service</b>	Air and non-combustible, compatible gases	Air and non-combustible, compatible gases	Air and compatible gases
<b>Wetted Materials</b>	Consult factory	Consult factory	Consult factory
<b>Housing</b>	Die cast aluminum case and bezel	Glass filled plastic	Glass filled nylon
<b>Lens</b>	Clear acrylic	N/A	Clear acrylic
<b>Accuracy</b>	±2 to 4% FS for most models. ±1 to 2% FS with HA option	±1% FS (2% FS for ranges 1 in w.c. and below)	±5% FS
<b>Pressure Limits</b>	-20" Hg to 15 psig (-0.677 bar to 1.034 bar); MP option: 35 psig (2.41 bar); HP option: 80 psig (5.52 bar).	2 psi (14 kPa) for ≤5 in w.c. 11 psi (75 kPa) for ≥10 in w.c.	30 psig (2.067 bar)
<b>Temperature Limits</b>	20 to 140°F (-6.67 to 60°C)	0 to 140°F (-18 to 60°C)	20 to 120°F (-6.67 to 48.9°C)
<b>Process Connection</b>	1/8" female NPT duplicate high and low pressure taps	1/8" (3 mm) ID tubing	Barbed for 3/16" ID tubing or 1/8" male NPT
<b>Enclosure Rating</b>	N/A	NEMA 4X (IP66)	N/A

# DIFFERENTIAL PRESSURE

## Bezels

				
<b>SERIES</b>	<b>2000-SS</b> - page 22	<b>2000-SB</b> - page 22	<b>2000-CB</b> - page 22	<b>DH3-SS/3000MR(S)-SS/605-SS</b> - pages 36, 42 & 64
<b>Accessory</b>	Bezel	Bezel	Bezel	Bezel
<b>Material</b>	304 brushed stainless steel	304 stainless steel	Chrome plated aluminum	304 brushed stainless steel
<b>Dimensions</b>	4-3/4" (120.7 mm) OD	4-3/4" (120.7 mm) OD	4-3/4" (120.7 mm) OD	4-3/4" (120.7 mm) OD
<b>Aesthetics/Function</b>	Tapered brushed/matte SS finish	Electro polished Ra 16	Chrome finish	Tapered brushed/matte SS finish
<b>Part Sold Separately</b>	Yes	Yes	Yes	Yes
<b>Part Number</b>	420141-40	420141-10	420141-00	815999-10

These Selection Guides are for quick comparison of similar products. Please refer to the catalog page number referenced for complete product information and specifications.





# DIFFERENTIAL PRESSURE

## Pressure Gages

			
<b>SERIES</b>	<b>4000</b> - page 31	<b>PTGD</b> - page 32	<b>PFG2</b> - page 33
<b>Ranges</b>	0 to 5 in w.c. up to 0 to 20 psid	5 to 150 psid (0.25 to 10 bar)	5 to 25 psid
<b>Service</b>	Air and compatible gases and oil based liquids	Compatible gases and liquids	Liquids/gases compatible with SS, GFN, and fluoropolymer
<b>Wetted Materials</b>	Consult factory	Aluminum or 316 SS piston; Buna-N, PTFE, or ceramic magnet seals	Aluminum mounting block
<b>Housing</b>	Die cast aluminum with impregnated hard coating	Aluminum or 316 SS	Glass filled nylon
<b>Lens</b>	N/A	Acrylic	Polyester
<b>Accuracy</b>	±3% FS (±2% or 4% for certain ranges)	±2% FS	±5% FS
<b>Pressure Limits</b>	-20" Hg to 500 psig (-0.68 to 34.4 bar)	Aluminum: 3000 psi (206 bar); SS: 6000 psi (413 bar)	300 psig (20.7 bar)
<b>Temperature Limits</b>	20 to 200°F (-6.7 to 93.3°C)	N/A	200°F (93°C)
<b>Process Connection</b>	1/4" female NPT duplicate high and low pressure taps	1/4" female NPT	1/8" female NPT
<b>Enclosure Rating</b>	N/A	N/A	N/A

# DIFFERENTIAL PRESSURE





## Accessories

				
<b>SERIES</b>	<b>AHU1/2</b> - page 22	<b>A-464</b> - page 23	<b>A-320-A</b> - page 23	<b>Scale Customization</b> - Consult Factory
<b>Accessory</b>	Surface mounting kit	Flush mounting kit	Enclosure	Customized logos/company name
<b>Material</b>	ABS plastic	White ABS plastic	ABS	Printed on aluminum scale
<b>Dimensions</b>	4-1/2" x 4-1/2"	6-1/2" x 6-1/2"	4-23/32" x 3-37/64" x 6-19/64"	As per customer requirement
<b>Enclosure Rating</b>	N/A	N/A	NEMA 1 (IP10)	N/A
<b>Mounting Orientation</b>	Surface	Flush	Wall	N/A
<b>Aesthetics/Function</b>	Quick Install accessory	Cleanroom mount	Quick install kit	Customize your application
<b>Part Sold Separately</b>	Yes	Yes	Yes	N/A
<b>Part Number</b>	A-607/A-607 with A-481	A-464	A-320-A	N/A

These Selection Guides are for quick comparison of similar products. Please refer to the catalog page number referenced for complete product information and specifications.



# DIFFERENTIAL PRESSURE

## Pressure Gages/Switches

				
<b>SERIES</b>	<b>DHII</b> - page 34	<b>DH</b> - page 35	<b>DH3</b> - page 36	<b>A3000</b> - pages 38-39
<b>Ranges</b>	0.25 to 100 in w.c. (60 Pa to 24.88 kPa) (Bi-directional ranges available)	0.25 to 100 in w.c. (60 Pa to 24.88 kPa) (Bi-directional ranges available)	0.25 to 100 in w.c. (60 Pa to 24.88 kPa) (Bi-directional ranges available)	0 to 0.25 in w.c. (0 to 60 Pa) up to 0 to 150 in w.c. (0 to 30 kPa)
<b>Service</b>	Air and non-combustible, compatible gases	Air and non-combustible, compatible gases	Air and non-combustible, compatible gases	Air and non-combustible, compatible gases
<b>Wetted Materials</b>	Consult factory	Consult factory	Consult factory	Consult factory
<b>Housing</b>	Aluminum, glass	ABS plastic, UL approved 94 V-0	Die cast aluminum case and bezel	N/A
<b>Switch Type</b>	(2) SPDT	(2) SPDT	(2) SPDT	(2) DPDT
<b>Accuracy</b>	±0.5% FS	±0.5% FS	±0.5% FS (±1% or ±1.5 for certain ranges)	±2% FS (±3% or 4% for certain ranges)
<b>Pressure Limits</b>	2 psi (≤2.5 in w.c.); 5 psi (5 to 50 in w.c.); 9 psi (100 in w.c.)	2 psi (≤2.5 in w.c.); 5 psi (5 to 50 in w.c.); 9 psi (100 in w.c.)	2 psi (≤2.5 in w.c.); 5 psi (5 to 50 in w.c.); 9 psi (100 in w.c.)	-20" Hg to 25 psig (-0.677 bar to 1.72 bar); MP option: 35 psig (2.41 bar); HP option: 80 psig (5.52 bar).
<b>Temperature Limits</b>	32 to 140°F (0 to 60°C)	32 to 140°F (0 to 60°C)	32 to 140°F (0 to 60°C)	20 to 120°F (-6.67 to 48.9°C)
<b>Process Connection</b>	1/8" female NPT	Compression fitting for 1/8" ID tubing or barbed fitting for 3/16" ID tubing	1/8" female NPT	1/8" female NPT
<b>Enclosure Rating</b>	NEMA 4 (IP66)	NEMA 4X (IP66)	N/A	N/A

# LOW DIFFERENTIAL PRESSURE





## Pressure Switches

				
<b>SERIES</b>	<b>ADPS</b> - page 45	<b>EDPS</b> - page 45	<b>1800</b> - page 47	<b>1900</b> - page 49
<b>Set Point Range</b>	.08 to 20 in w.c. (20 to 5000 Pa)	.08 to 20 in w.c. (20 to 5000 Pa)	.07 to 85 in w.c. (.017 to 21 kPa)	.07 to 20 in w.c. (.017 to 5 kPa)
<b>Service</b>	Compatible gases	Compatible gases	Compatible gases	Compatible gases
<b>Wetted Materials</b>	Silicone, PA 6.6, and Polystyrene	Silicone, PA 6.6, and materials UL 94 V-0 rated	Consult factory	Consult factory
<b>Temperature Limits</b>	-4 to 185°F (-20 to 85°C)	-4 to 185°F (-20 to 85°C)	-30 to 180°F (-34 to 82°C)	-30 to 180°F (-34 to 82°C)
<b>Pressure Limits</b>	40 in w.c. (10 kPa)	40 in w.c. (10 kPa)	10 psig (69 kPa)	45 in w.c. (11.2 kPa)
<b>Power Requirement</b>	None	None	None	None
<b>Repeatability</b>	1%	1%	2%	3%
<b>Adjustable Deadband</b>	No	No	No	No
<b>Set Point Indication</b>	Yes	Yes	No	No
<b>Enclosure Rating</b>	GP	UL 94 V-0 rated	GP, WP, or EXP	GP, WP, or EXP
<b>Switch Type</b>	SPDT	SPDT	SPDT	SPDT
<b>Multiple Stages</b>	No	No	No	No
<b>Process Connection</b>	Hose connection for 5/16" OD and 1/4" ID tubing	Hose connection for 5/16" OD and 1/4" ID tubing	1/8" female NPT	1/8" female NPT

These Selection Guides are for quick comparison of similar products. Please refer to the catalog page number referenced for complete product information and specifications.





# DIFFERENTIAL PRESSURE

## Pressure Gages/Switches

				
<b>SERIES</b>	<b>43000</b> - page 41	<b>3000MR</b> - page 42	<b>3000MRS</b> - page 42	<b>MP</b> - page 44
<b>Ranges</b>	0 to 0.5 in w.c. up to 0 to 500 in w.c.	0 to 0.25 in w.c. (0 to 60 Pa) up to 0 to 100 in w.c. (0 to 4 kPa)	0 to 0.25 in w.c. (0 to 60 Pa) up to 0 to 100 in w.c. (0 to 4 kPa)	0 to 0.5 in w.c. (0 to 125 kPa) up to 0 to 20 in w.c. (0 to 3 kPa)
<b>Service</b>	Compatible gases and liquids	Air and non-combustible compatible gases	Air and non-combustible compatible gases	Air and non-combustible, compatible gases
<b>Wetted Materials</b>	Consult factory	Consult factory	Consult factory	Consult factory
<b>Housing</b>	N/A	N/A	N/A	N/A
<b>Switch Type</b>	(2) DPDT	SPDT	Solid state relay	(2) SPDT
<b>Accuracy</b>	±3% FS (±4% for certain ranges)	±2% FS (±3% or 4% for certain ranges)	±2% FS (±3% or 4% for certain ranges)	±5% FS
<b>Pressure Limits</b>	-20" Hg to 500 psig (-0.677 bar to 34.5 bar)	-20" Hg to 25 psig (-0.677 bar to 1.72 bar)	-20" Hg to 25 psig (-0.677 bar to 1.72 bar)	30 psig (2.067 bar)
<b>Temperature Limits</b>	20 to 120°F (-6.67 to 48.9°C)	20 to 120°F (-6.67 to 48.9°C)	20 to 120°F (-6.67 to 48.9°C)	20 to 120°F (-6.67 to 49°C)
<b>Process Connection</b>	1/4" female NPT	1/8" female NPT	1/8" female NPT	Barbed for 3/16" ID tubing or 1/8" male NPT
<b>Enclosure Rating</b>	N/A	N/A	N/A	N/A

# LOW DIFFERENTIAL PRESSURE





## Pressure Switches

				
<b>SERIES</b>	<b>MDS</b> - page 51	<b>MDA</b> - page 51	<b>1831</b> - page 52	<b>1640</b> - page 52
<b>Set Point Range</b>	.5 to 50 in w.c. (.12 to 12.5 kPa)	.1 to 100 in w.c. (.25 to 249.1 mbar)	2.5 to 23 in w.c. (.62 to 5.7 kPa)	.01 to 12 in w.c. (.003 to 3 kPa)
<b>Service</b>	Air or compatible fluids on "high side"	Air or compatible fluids on "high side"	Compatible gases	Compatible gases
<b>Wetted Materials</b>	Polycarbonate and polyurethane	Polycarbonate and polyurethane	Consult factory	Consult factory
<b>Temperature Limits</b>	40 to 150°F (4 to 66°C)	40 to 150°F (4 to 66°C)	-30 to 180°F (-34 to 82°C)	-30 to 110°F (-34 to 43°C)
<b>Pressure Limits</b>	15 psig (1 bar)	15 psig (1 bar)	10 psig (69 kPa)	10 psig (69 kPa)
<b>Power Requirement</b>	None	None	None	None
<b>Repeatability</b>	Consult factory	Consult factory	4%	Consult factory
<b>Adjustable Deadband</b>	No	No	No	No
<b>Set Point Indication</b>	No	No	No	Yes
<b>Enclosure Rating</b>	GP	GP	GP	GP, WP, or EXP
<b>Switch Type</b>	SPST NO	SPST NO	DPDT	SPDT
<b>Multiple Stages</b>	No	No	No	Yes
<b>Process Connection</b>	Hose barb for 1/8"-3/16" ID tubing	Smooth port for 1/8" ID tubing	1/8" female NPT	1/8" female NPT

These Selection Guides are for quick comparison of similar products. Please refer to the catalog page number referenced for complete product information and specifications.



# LOW DIFFERENTIAL PRESSURE

## Pressure Switches

				
<b>SERIES</b>	<b>1620</b> - page 53	<b>1630</b> - page 53	<b>PG</b> - page 54	<b>1950</b> - page 55
<b>Set Point Range</b>	.15 to 24 in w.c. (.04 to 6 kPa)	.05 to 12 in w.c. (.012 to 3 kPa)	1 in w.c. to 5 psig (.25 kPa to 3.4 bar)	.03 to 20 in w.c. (.007 to 5 kPa)
<b>Service</b>	Compatible gases	Compatible gases	Compatible gases	Compatible gases
<b>Wetted Materials</b>	Consult factory	Consult factory	Fairprene, brass, steel, and aluminum	Consult factory
<b>Temperature Limits</b>	-30 to 130°F (-34 to 54°C)	-30 to 110°F (-34 to 43°C)	-10 to 180°F (-23 to 82°C)	-40 to 140°F (-40 to 60°C)
<b>Pressure Limits</b>	50 in w.c. (12.41 kPa)	10 psig (69 kPa)	Consult factory	45 in w.c. (11.2 kPa)
<b>Power Requirement</b>	None	None	None	None
<b>Repeatability</b>	1%	1%	1%	Consult factory
<b>Adjustable</b>	No	No	No	No
<b>Deadband</b>				
<b>Set Point Indication</b>	No	Yes	Yes	No
<b>Enclosure Rating</b>	GP and WP	GP and WP	GP, WP, or EXP	WP and EXP
<b>Switch Type</b>	(2) SPDT	SPDT	SPDT or DPDT	SPDT
<b>Multiple Stages</b>	Yes	No	No	No
<b>Process Connection</b>	1/8" female NPT	1/8" female NPT	1/8" female and 1/2" male NPT	1/8" female NPT

# LOW DIFFERENTIAL PRESSURE - NON-INDICATING

## Pressure Transmitters and Transducers

			
<b>SERIES</b>	<b>616KD</b> - page 58	<b>668B/D</b> - page 60	<b>608</b> - page 74
<b>Ranges</b>	1 to 20 in w.c. (250 to 5000 Pa) to 5000 Pa (Bi-directional available)	.1 to 100 in w.c. (25 to 25000 Pa) (Bi-directional available)	0.1 to 25 in w.c. (25 to 6200 Pa) (Bi-directional available)
<b>Accuracy</b>	616KD-A: ±0.25% FS; 616KD-B: ±1% FS; 616KD-C: ±2% FS	±0.8% FS	±0.5% or ±0.25% FS
<b>Wetted Materials</b>	Consult factory	Consult factory	Consult factory
<b>Comp. Temp. Limits</b>	20 to 122°F (-6.67 to 50°C)	40 to 170°F (4.4 to 77°C)	0 to 160°F (-18 to 71°C)
<b>Oper. Temp. Limits</b>	0 to 140°F (-17.8 to 60°C)	0 to 170°F (-18 to 77°C)	-20 to 185°F (-28 to 85°C)
<b>Output Signal</b>	4 to 20 mA or field selectable 0 to 10/0 to 5/2 to 10/1 to 5 V	4 to 20 mA, 0 to 10 VDC, or 0 to 5 VDC	4 to 20 mA
<b>Elec. Connection</b>	Screw-type terminal block	Screw-type terminal block	Screw-type terminal block, Two 1/2" female NPT conduit
<b>Process Connection</b>	Barbed for 1/8" and 3/16" ID rubber or vinyl tubing	3/16" OD barbed brass for 1/8" ID push-on tubing	1/4" female NPT
<b>Enclosure Rating</b>	NEMA 1 (IP20)	UL 94 V-0 rated	NEMA 4X (IP66)

These Selection Guides are for quick comparison of similar products. Please refer to the catalog page number referenced for complete product information and specifications.

# LOW DIFFERENTIAL PRESSURE

## Pressure Switches





<b>SERIES</b>	<b>1950G</b> - page 55	<b>H3</b> - page 56	<b>DX</b> - page 57
<b>Set Point Range</b>	.07 to 20 in w.c. (.017 to 5 kPa)	180 in w.c. to 200 psid (0.5 to 13.5 bar)	2.5 to 75 psi (.17 to 5.2 bar)
<b>Service</b>	Compatible gases	Compatible liquids or gases	Compatible liquids or gases
<b>Wetted Materials</b>	Consult factory	Aluminum/Nitrile or SS/ Fluoroelastomer	Brass and fluoroelastomer
<b>Temperature Limits</b>	0 to 140°F (-18 to 60°C)	-4 to 220°F (-20 to 104°F)	30 to 140°F (-1 to 60°C)
<b>Pressure Limits</b>	45 in w.c. (11.2 kPa)	1500 psig (103 bar)	200 psig (13.8 bar)
<b>Power Requirement</b>	24 VDC, 120 or 240 VAC	None	None
<b>Repeatability</b>	Consult factory	Consult factory	2%
<b>Adjustable Deadband</b>	No	No	Yes
<b>Set Point Indication</b>	No	No	No
<b>Enclosure Rating</b>	WP and EXP	EP	WP
<b>Switch Type</b>	SPDT	SPDT or DPDT	SPDT
<b>Multiple Stages</b>	No	No	No
<b>Process Connection</b>	1/8" female NPT	1/8" female NPT	1/4" female NPT







# LOW DIFFERENTIAL PRESSURE - INDICATING

## Pressure Transmitters and Transducers

			
<b>SERIES</b>	<b>616W</b> - page 62	<b>DM-2000</b> - page 63	<b>605</b> - page 64
<b>Ranges</b>	6 in w.c. to 2.5 kPa	.1 to 5 in w.c. (Bi-directional available)	Vacuum, .5 to 50 in w.c. (60 to 1500 Pa)
<b>Accuracy</b>	±0.25% FS, display accuracy ±0.5%	±1% FS	±0.5% or ±2% FS
<b>Wetted Materials</b>	Consult factory	Consult factory	Consult factory
<b>Comp. Temp. Limits</b>	N/A	N/A	32 to 120°F (0 to 48.9°C)
<b>Oper. Temp. Limits</b>	0 to 150°F (-17.8 to 66°C)	20 to 120°F (-7 to 49°C)	20 to 120°F (-6.67 to 48.9°C)
<b>Output Signal</b>	4-20 mA (2-wire), 0-5 VDC, or 0-10 VDC (3-wire)	4-20 mA	4-20 mA
<b>Elec. Connection</b>	3-wire terminal block for 16 to 26 AWG	Screw-type terminal block	Screw-type terminal block
<b>Process Connection</b>	Barbed for 1/8" and 3/16" ID rubber or vinyl tubing	1/8" ID tubing	1/8" female NPT
<b>Enclosure Rating</b>	NEMA 4X (IP66)	N/A	N/A

# WET-WET DIFFERENTIAL PRESSURE

## Pressure Transmitters and Transducers

				
<b>SERIES</b>	<b>3100</b> - pages 70-71	<b>636D</b> - page 75	<b>629C</b> - page 76	<b>629C-3V</b> - page 76
<b>Ranges</b>	6 in w.c. to 0-1000 psig	15 to 300 psi	5 to 500 psid (0.5 to 30 bar)	5 to 500 psid (0.5 to 30 bar)
<b>Accuracy</b>	±0.075% FS	±0.5% FS	±0.50% FS	±0.50% FS
<b>Wetted Materials</b>	316L SS	316L SS	316, 316L SS	316, 316L SS, Brass 360, Copper, Reinforced acetal copolymer
<b>Comp. Temp. Limits</b>	N/A	-20 to 180°F (-29 to 82°C)	0 to 175°F (-18 to 79°C)	0 to 175°F (-18 to 79°C)
<b>Oper. Temp. Limits</b>	-40 to 185°F (-40 to 85°C)	-40 to 212°F (-40 to 100°C)	0 to 200°F (-18 to 93°C)	0 to 200°F (-18 to 93°C)
<b>Output Signal</b>	4-20 mA or HART® Communication	4-20 mA or 1 to 5 VDC	2-wire: 4-20 mA; 3-wire: Selectable 0-5, 1-5, 0-10, or 2-10 VDC	2-wire: 4-20 mA; 3-wire: Selectable 0-5, 1-5, 0-10, or 2-10 VDC
<b>Elec. Connection</b>	(2) 1/2" female NPT conduit, screw terminal	2' (61 cm) cable, 3/4" female NPT conduit	Screw-type removable terminal block; 1/2" female NPT conduit	Screw-type removable terminal block; 1/2" female NPT conduit
<b>Process Connection</b>	1/4" female NPT	1/2" female NPT	1/4" female NPT	1/4" female NPT
<b>Enclosure Rating</b>	NEMA 4X (IP66)	NEMA 4 (IP66)	NEMA 4X (IP66)	Non-LCD designed to meet NEMA 4X (IP66)

HART® is a registered trademark of Hart Communication Foundation

These Selection Guides are for quick comparison of similar products. Please refer to the catalog page number referenced for complete product information and specifications.

# LOW DIFFERENTIAL PRESSURE - INDICATING

## Pressure Transmitters and Transducers



SERIES	MS2 - page 66	ISDP - page 69
Ranges	0.1 in w.c. to 28 in w.c. (25 Pa to 6975 Pa) (Bi-directional available)	0.1 to 100 in w.c. (Bi-directional available)
Accuracy	±1% or ±2% FS	±0.5% FS
Wetted Materials	Consult factory	Consult factory
Comp. Temp. Limits	N/A	32 to 140°F (0 to 60°C)
Oper. Temp. Limits	0 to 150°F (-18 to 66°C)	32 to 140°F (0 to 60°C)
Output Signal	4-20 mA (2-wire), 0-5 VDC, 0-10 VDC (3-wire)	4-20 mA DC
Elec. Connection	3-wire terminal block for 16 to 22 AWG	M-12 4-pin connector
Process Connection	3/16" I.D. tubing (5 mm ID); Max OD 9 mm	1/8" female NPT
Enclosure Rating	NEMA 4X (IP66)	NEMA 4X (IP66)

# WET-WET DIFFERENTIAL PRESSURE

## Pressure Transmitters and Transducers





SERIES	629HLP - page 77	647 - page 78	645 - page 79	WWDP - page 80
Ranges	15 to 90 psi (1 to 6 bar)	1 in w.c. to 0-30 psid (245 Pa to 0-2.0 bar)	1 to 100 psid (0.07 to 6.5 bar) (Bi-directional ranges available)	5 to 250 psi
Accuracy	±1% FS	±1% FS	±0.25% FS	±1% FS
Wetted Materials	304 SS	Brass, vinyl, glass-filled polyester, silicon, fluorosilicone	17-4 PH SS, Fluoroelastomer, Silicone	Consult factory
Comp. Temp. Limits	-5 to 60°C (23 to 140°F)	N/A	30 to 150°F (-1 to 65°C)	32 to 130°F (0 to 54°C)
Oper. Temp. Limits	-10 to 80°C (14 to 176°F)	32 to 122°F (0 to 50°C)	0 to 175°F (-18 to 80°C)	-4 to 185°F (-20 to 85°C)
Output Signal	4-20 mA, 0-10 VDC	4-20 mA	4-20 mA	Selectable 0-5, 0-10, and 0-5 VDC; 4-20 mA
Elec. Connection	Form A DIN 43650	Screw-type terminal block	Screw-type terminal block	1/2" conduit
Process Connection	1/4" female NPT, 1/4" female BSPT	1/8" female NPT	1/4" female NPT	1/8" female NPT internal
Enclosure Rating	IP65	N/A	NEMA 4X (IP66)	NEMA 4 (IP66)

These Selection Guides are for quick comparison of similar products. Please refer to the catalog page number referenced for complete product information and specifications.

# SINGLE PRESSURE

## Pressure Gages

			
<b>SERIES</b>	<b>LPG4/LPG5</b> - pages 81-82	<b>SGY &amp; SGZ</b> - pages 83	<b>765</b> - page 83
<b>Ranges</b>	-235 to 160 in w.c. (-60 to 40 kPa)	-30" Hg to 1000 psi (-1 to 70 bar)	30" Hg to 20,000 psi (-100 to 135,000 kPa)
<b>Service</b>	Compatible gases/liquids	Compatible gases/liquids	Compatible gases/liquids
<b>Wetted Materials</b>	Brass, bronze or SS	Brass, bronze or SS	316L SS, Bourdon tube
<b>Housing</b>	LPG4: Drawn Steel; LPG5: Chrome plated	304 SS	Phenolic plastic with safety blow-out back
<b>Accuracy</b>	LPG4 ±1.5% FS; LPG5 ±3%-2%-3% FS	±1.5 to ±2.5% FS	±0.5% FS ANSI/ASME (Grade 2A)
<b>Pressure Limits</b>	100% FS	100% FS	110 to 125% FS
<b>Temperature Limits</b>	Ambient: -40 to 140°F (-40 to 60°C); LPG5 -4 to 140°F (-20 to 60°C)	-4 to 140°F (-20 to 60°C)	-40 to 200°F (-40 to 93°C)
<b>Process Connection</b>	1/4" male NPT	1/4" male NPT	1/4" or 1/2" male NPT
<b>Enclosure Rating</b>	N/A	NEMA 3 (IP54)	IP65 (NEMA 4)

# HIGH SINGLE PRESSURE - INDICATING

## Pressure Transmitters and Transducers



					
<b>SERIES</b>	<b>DSGT</b> - page 87	<b>EDA</b> - page 89	<b>626/628-CB</b> - pages 102-103	<b>IWP</b> - page 105	<b>3200G</b> - pages 106-107
<b>Ranges</b>	30 to 20,000 psig and compound ranges	20 to 3000 psig	Up to 300 psia, 8000 psig, 16 bar abs, 550 bar	30 to 1000 psig	-14.5 psig to 8500 psig
<b>Accuracy</b>	±0.25% FS	±1% FS	626: ±0.25% FS; 628: ±1% FS	±0.5% FS	±0.075% FS
<b>Wetted Materials</b>	17-4 SS, 316 SS	316L SS	316, 316L SS	304 and 316 SS	316L SS
<b>Comp. Temp. Limits</b>	N/A	32 to 122°F (0 to 50°C)	0 to 175°F (0 to 79°C)	-22 to 203°F (-30 to 95°C)	N/A
<b>Oper. Temp. Limits</b>	14 to 140°F (-10 to 60°C)	20 to 140°F (-6.6 to 60°C)	0 to 200°F (0 to 94°C)	32 to 158°F (0 to 70°C)	-40 to 185°F (-40 to 85°C)
<b>Output Signal</b>	4-20 mA	4-20 mA, 1-6 VDC, 1-5 VDC, 0-5 VDC, or 0-10 VDC	4-20 mA	4-20 mA	4-20 mA or HART® Communication
<b>Elec. Connection</b>	3' flying leads	Screw-type removable terminal blocks with (2) 1/2" female NPT conduit connections	Terminal block, 1/2" female NPT conduit	1/2" female NPT	(2) 1/2" female NPT conduit, screw terminal
<b>Process Connection</b>	1/2" male NPT	1/4" male NPT, 1/4" male BSPT, or 7/16" SAE	1/4" male or female NPT or BSPT	1/2" female NPT	1/2" female NPT
<b>Enclosure Rating</b>	NEMA 4X	NEMA 4X (IP66)	NEMA 4X (IP66)	IP65	NEMA 4X (IP66)

HART® is a registered trademark of Hart Communication Foundation

These Selection Guides are for quick comparison of similar products. Please refer to the catalog page number referenced for complete product information and specifications.





# DIGITAL SINGLE PRESSURE

## Pressure Gages

					
<b>SERIES</b>	<b>DPGA</b> - page 84	<b>DPGW</b> - page 84	<b>DPG-000</b> - page 85	<b>DPG-100</b> - page 85	<b>DPG-200</b> - page 87
<b>Ranges</b>	-30" Hg to 500 psig (-1.013 to 34.47 bar)	-30" Hg to 500 psig (-1.013 to 34.47 bar)	-14.7 to 8000 psig (-1.0 to 550 bar)	-14.7 to 8000 psig (-1.0 to 550 bar)	5 to 8000 psig (0.3 to 550 bar)
<b>Service</b>	Air and compatible gases	Compatible gases/liquids	Compatible liquids and combustible gases	Compatible liquids and combustible gases	Liquids and non-combustible compatible gases
<b>Wetted Materials</b>	316L SS, silicone sensor	316L SS	Type 316L SS	Type 316L SS	Type 316L SS
<b>Housing</b>	ABS plastic	ABS plastic	Polycarbonate front and back cover, anodized aluminum housing, polycarbonate overlay, Buna-N O-rings, 316L SS sensor construction	Polycarbonate front and back cover, anodized aluminum housing, polycarbonate overlay, Buna-N O-rings, 316L SS sensor construction	Polycarbonate front and back cover, anodized aluminum housing, polycarbonate overlay, Buna-N O-rings, 316L SS sensor construction
<b>Accuracy</b>	±1% FS	±1% FS	±0.5% FS	±0.25% FS	±0.25% FS
<b>Pressure Limits</b>	200% FS; 30 psig for vacuum models	200% FS; 30 psig for vacuum models	200% FS (≤1000 psi); 5000 psi (3000 psi); 7500 psi (5000 psi)	200% FS (≤1000 psi); 5000 psi (3000 psi); 7500 psi (5000 psi)	200% FS (≤1000 psi); 5000 psi (3000 psi); 7500 psi (5000 psi)
<b>Temperature Limits</b>	30 to 120°F (-1 to 49°C)	30 to 120°F (-1 to 49°C)	0 to 130°F (-18 to 55°C)	0 to 130°F (-18 to 55°C)	0 to 158°F (-18 to 70°C)
<b>Process Connection</b>	1/4" male NPT	1/4" male NPT	1/4" male NPT	1/4" male NPT	1/4" male NPT
<b>Enclosure Rating</b>	N/A	N/A	NEMA 4/4X (IP66)	NEMA 4/4X (IP66)	NEMA 4X (IP66)

# SINGLE PRESSURE

## Pressure Switches





						
<b>SERIES</b>	<b>EDA</b> - page 89	<b>DA/DS</b> - pages 90	<b>SA1100</b> - page 92	<b>1000W/E</b> - page 93	<b>A1F</b> - page 94	<b>A1PS/A1VS</b> - page 95
<b>Set Point Range</b>	20 to 3000 psig (1.38 to 206 bar)	30" Hg VAC to 8000 psig (762 mm Hg VAC to 551 bar)	10 to 500 psig (.7 to 34 bar)	5 to 1400 psig (.48 to 96.5 bar)	2 to 450 psig (.14 to 10.3 bar)	28" Hg VAC to 500 psig (711 mm Hg VAC to 34.5 bar)
<b>Service</b>	Compatible liquids or gases	Compatible liquids or gases	Compatible liquids or gases	Compatible liquids or gases	Compatible liquids or gases	Compatible liquids or gases
<b>Wetted Materials</b>	316 SS	Brass, 403 SS, or 316 SS	Aluminum, brass, or 316 SS with Buna-N or fluorocarbon	Aluminum or 316 SS with polyamide, 316 SS, or Teflon®	Fluorocarbon and 316 SS	Zinc and Buna-N
<b>Temperature Limits</b>	20 to 140°F (-6.6 to 60°C)	-10 to 180°F (-23 to 82°C)	-30 to 180°F (-35 to 77°C)	-30 to 170°F (-35 to 77°C)	-40 to 175°F (-40 to 80°C)	-31 to 185°F (-35 to 85°C)
<b>Pressure Limits</b>	4500 psig (310 bar)	8000 psig (551 bar)	3000 psig (207 bar)	3000 psig (207 bar)	750 psig (51 bar)	600 psig (41 bar)
<b>Power Requirement</b>	12-30 VDC/AC	None	None	None	None	None
<b>Repeatability</b>	0.5%	1%	Consult factory	Consult factory	Consult factory	Consult factory
<b>Adjustable Deadband</b>	Yes	Yes	Yes	No	No	No
<b>Set Point Indication</b>	Yes	Yes	Yes	Yes	Yes	Yes
<b>Enclosure Rating</b>	WP	GP, WP, or EXP	WP and EXP	WP or EXP	GP or WP	GP
<b>Switch Type</b>	(2) SPDT	SPDT or DPDT	SPDT or DPDT	SPDT or DPDT	SPDT	SPDT
<b>Multiple Stages</b>	No	Yes	No	No	No	No
<b>Process Connection</b>	1/4" male NPT	GP/WP: 1/4" male NPT or 1/2" male NPT; EXP: 1/2" male NPT and 1/4" female NPT	1/4" or 1/2" female NPT	1/4" female NPT	1/4" female and 1/2" male NPT	1/4" male NPT

Teflon® is a registered trademark of E.I. DuPont De Nemours and Company

These Selection Guides are for quick comparison of similar products. Please refer to the catalog page number referenced for complete product information and specifications.

# SINGLE PRESSURE

## Pressure Switches

						
<b>SERIES</b>	<b>APS/AVS</b> - page 95	<b>A6</b> - page 96	<b>AP</b> - page 96	<b>A2</b> - page 97	<b>MVS</b> - page 97	<b>CXA</b> - page 98
<b>Set Point Range</b>	28" Hg VAC to 500 psig (711 mm Hg VAC to 34.5 bar)	.5 to 150 psig (.03 to 10.3 bar)	10 in w.c. VAC to 125 psig (2.5 kPa VAC to 8.6 bar)	5 to 150 psig (.34 to 10 bar)	3 to 330 in w.c. VAC (8 to 822 mbar VAC)	15 to 150 psig (1.0 to 10.3 bar)
<b>Service</b>	Compatible liquids or gases	Compatible liquids or gases	Compatible liquids or gases	Compatible liquids or gases	Compatible liquids or gases	Compatible liquids or gases
<b>Wetted Materials</b>	17-4 PH SS and 303 SS	Polyimide with brass or 304 SS	Steel and Buna-N 04 316 SS and Teflon®	Kapton® and brass	Polycarbonate and polyurethane	Silicone, steel, and SS
<b>Temperature Limits</b>	-65 to 225°F (-54 to 107°C)	-40 to 248°F (-40 to 120°C)	-30 to 150°F (-35 to 66°C)	-40 to 250°F (-40 to 121°C)	40 to 150°F (4 to 66°C)	140°F (60°C)
<b>Pressure Limits</b>	750 psig (51 bar)	500 psig (34 bar)	160 psig (11 bar)	500 psig (34 bar)	330 in w.c. (822 mbar)	204 psig (14.1 bar)
<b>Power Requirement</b>	None	None	None	None	None	None
<b>Repeatability</b>	Consult factory	±10%	Consult factory	5%	20%	±5 psig (.3 bar)
<b>Adjustable Deadband</b>	No	No	No	No	No	Yes
<b>Set Point Indication</b>	Yes	No	Yes	No	No	No
<b>Enclosure Rating</b>	GP	GP or WP	GP, WP, or EXP	GP or submersible	GP	GP
<b>Switch Type</b>	SPDT	(1) SPST NO and (1) SPST NC	SPDT or DPDT	SPST	SPDT	SPST NO or NC
<b>Multiple Stages</b>	No	No	No	No	No	No
<b>Process Connection</b>	1/8" mail NPT	1/4" male NPT	1/4" female NPT	1/8" male NPT	Consult factory	1/4" female NPT

Teflon® is a registered trademark of E.I. DuPont De Nemours and Company

These Selection Guides are for quick comparison of similar products. Please refer to the catalog page number referenced for complete product information and specifications.

# HIGH SINGLE PRESSURE - NON-INDICATING

## Pressure Transmitters and Transducers



<b>SERIES</b>	<b>681</b> - page 98	<b>644</b> - page 99	<b>682</b> - page 100	<b>672</b> - page 100	<b>673</b> - page 101
<b>Ranges</b>	1 to 100 psi	Vacuum, 15 to 1000 psig	25 to 10,000 psi	10 to 400 in w.c.	Compound, 1 to 1000 psi
<b>Accuracy</b>	±0.20% FS	±0.05% FS	±0.13% FS	±0.25% FS	±0.25% FS
<b>Wetted Materials</b>	316L SS	17-4 PH SS	17-4 PH SS	318 Duplex SS, Ceramic, fluoroelastomer	17-4 PH SS
<b>Comp. Temp. Limits</b>	20 to 180°F (-7 to 80°C)	-4 to 140°F (-20 to 60°C)	-4 to 176°F (-20 to 80°C)	-5 to 140°F (-20 to 60°C)	4 to 212°F (-20 to 100°C)
<b>Oper. Temp. Limits</b>	-40 to 260°F (-40 to 125°C)	-40 to 185°F (-40 to 85°C)	-40 to 260°F (-40 to 125°C)	-40 to 212°F (-40 to 100°C)	-40 to 260°F (-40 to 125°C)
<b>Output Signal</b>	4-20 mA	0-10 VDC (4-wire) or 4-20 mA (2-wire)	4-20 mA	4-20 mA or 0-5 VDC	4-20 mA
<b>Elec. Connection</b>	15 ft (4.5 m) multi-conduit cable	3' cable or 6-pin male bayonet connector	2 ft (61 cm) multi-conductor cable	Large DIN 43650 connector with mating plug	2 ft (61 cm) multi-conductor cable
<b>Process Connection</b>	1-1/2" or 2" sanitary clamp	1/4" male NPT	1/4" male or female NPT or BSPT	1/4"-18 male NPT	1/4" male NPT
<b>Enclosure Rating</b>	NEMA 4X (IP66)	NEMA 4X (IP66)	NEMA 4X (IP66)	NEMA 4X (IP66)	NEMA 4X (IP66)



# HIGH SINGLE PRESSURE - NON-INDICATING

## Pressure Transmitters and Transducers

					
<b>SERIES</b>	<b>638R</b> - page 99	<b>FDT</b> - page 101	<b>626/628-GH</b> - pages 102-103	<b>636</b> - page 104	<b>IS626</b> - page 110
<b>Ranges</b>	75 to 667 psia (5.2 to 46 bar(a))	100 to 10,000 psi (7 to 690 bar)	Up to 300 psia, 8000 psig, 16 bar abs, 550 bar	15 to 300 psi (1 to 20 bar)	15 to 8000 psig (1 to 550 bar); 15 to 30 psia (1 to 3 bara)
<b>Accuracy</b>	±1.2% FS	±0.5% FS	626: ±0.25% FS; 628: ±1% FS	±0.30% FS	±0.25% FS; 0.5% FS for absolute ranges
<b>Wetted Materials</b>	Brass, aluminum, or 316 SS	316 and 15-5 SS	316, 316L SS	316L SS	316 and 316L SS
<b>Comp. Temp. Limits</b>	-40 to 275°F (-40 to 135°C)	0 to 170°F (-18 to 77°C)	0 to 175°F (0 to 79°C)	-20 to 180°F (-29 to 82°C)	0 to 176°F (-18 to 80°C)
<b>Oper. Temp. Limits</b>	-40 to 275°F (-40 to 135°C)	-40 to 200°F (-40 to 93°C)	0 to 200°F (0 to 94°C)	-40 to 212°F (-40 to 100°C)	0 to 176°F (-18 to 80°C)
<b>Output Signal</b>	0.5-4.5 VDC ratiometric	4-20 mA or 0-5 VDC	4-20 mA	4-20 mA or 1-5 VDC	4-20 mA
<b>Elec. Connection</b>	Packard connection	4-pin	Cable, DIN connector, or 4-pin M12	2 ft (61 cm) cable, 3/4" female NPT conduit	3' cable or 4-pin M-12 connector
<b>Process Connection</b>	7/16" 20 UNF (female) or 1/4" NPT (female)	7/16-20 UNF male flush diaphragm; 1/4" male NPT	1/4" male or female NPT or BSPT	1/2" female NPT	1/4" male or female NPT or BSPT
<b>Enclosure Rating</b>	IP67	NEMA 4X (IP66)	NEMA 4X (IP66)	NEMA 4X (IP66)	NEMA 4X (IP66)

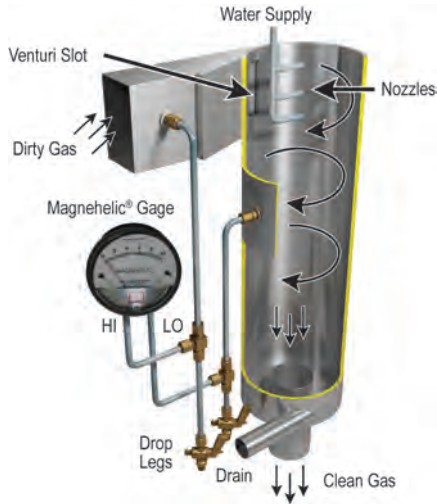

**Differential pressure gage assists operator in adjusting venturi pressure drop in dust scrubber.**

This scrubber design removes unwanted dust or particulate matter from air or gas using an adjustable throat venturi. To adjust the pressure drop across the venturi, a jack-screw-actuated sliding vane varies the slot width. A permanently mounted Dwyer® Magnehelic® differential pressure gage indicates the venturi pressure drop while the operator adjusts to the desired or design setting. Where water may possibly enter the gage sensing lines, as in this application, drop legs with drain valves are needed to permit draining the lines at their lowest point. Good engineering practice dictates that the Magnehelic® gage always be mounted above the sensing tap when possible to prevent moisture accumulation in the lines and gage. At minimum, mount the gage above the lowest point in the sensing lines.

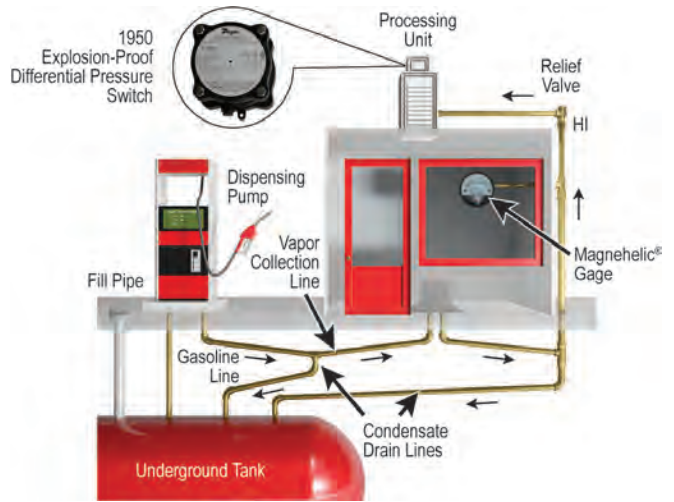

**Gasoline vapor recovery system.**

Some area pollution control agencies require that 90% or more of gasoline vapor vented at service stations when fuel is dispensed must be prevented from venting to atmosphere. Using a dual hose dispenser, this vapor recovery system is a vacuum assist, vapor burnoff type. The blower creates a low vacuum at the nozzle, routing vapor from the automobile tank to underground storage tanks. As uncondensed vapor pressure reaches 2 in to 3 in w.c. pressure, a Dwyer® 1950 Series explosion-proof differential pressure switch activates a rooftop burnoff unit, which ignites excess vapor. The Magnehelic® differential pressure gage mounted on the station wall monitors tank pressure to verify system operation. The gage is calibrated in inches of gasoline, from +6 to -2. This allows the operator to determine the necessary level correction due to tank pressure prior to dipsticking the tanks through the fill pipe.

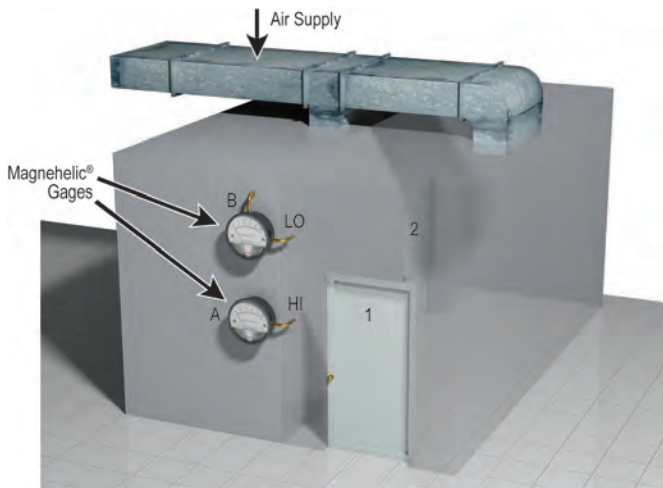

**Dwyer® gages indicate pressurization of special rooms.**

A zero-center Dwyer® Magnehelic® differential pressure gage with an 0.25 in w.c. range either side of zero makes an effective monitor for proper operation of room pressurization systems. In the example, differential gage B has its high pressure port open to room 2 and its low pressure port to room 1; gage A has its high pressure port open to room 1 and its low pressure port open to the atmosphere. With the makeup air supply damper adjusted properly, room 2 will be a higher pressure than room 1 which is at higher than atmospheric pressure; both gages will read positive. Should the air supply to room 2 be obstructed, gage B will read negative. If the air supply fails entirely, both gages will read zero. For even better security, a Photohelic® switch/gage will provide automatic alarm or start-up of a backup system.



**Filling scuba diver air tanks.**

The Dwyer® Series DPG with oxygen cleaning and 5000 psi range is used in gas blending applications for filling scuba diver's air tanks. The DPG is the master mixing gage in this manifold apparatus. Two or three gases may be blended with the manifold to produce the appropriate blend of breathable gas depending on the diver and the depths they will reach. With the flow adjustment knobs and the 0.25% full-scale accuracy DPG, precise tank charging rates are maintained.

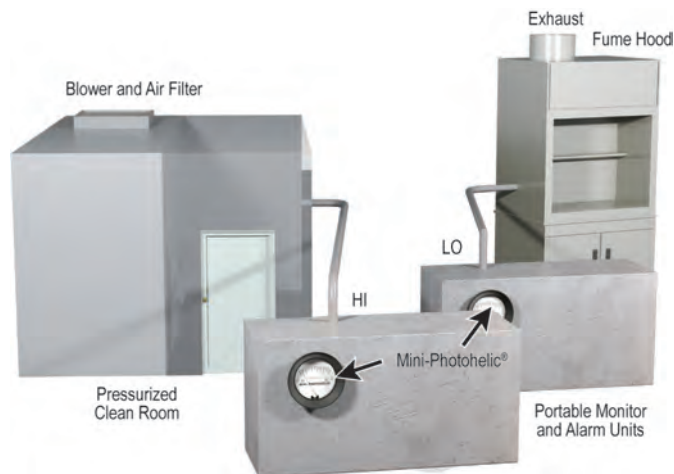

**Compact switch/gage monitors pressure, actuates alarm.**

This portable pressure monitor alarm utilizes a Dwyer® Mini-Photohelic® differential pressure switch/gage to monitor either positive pressure, as in a clean room, or negative pressure, as in a fume or paint spray hood. It sounds an alarm, both audible and visual, when pressure exceeds either a preset high or low limit. The unit can be used temporarily to verify proper operation after initial installation. Or it can be mounted permanently for continuous monitoring. In applications where a single fixed alarm pressure level is sufficient, a differential pressure switch can be used instead.

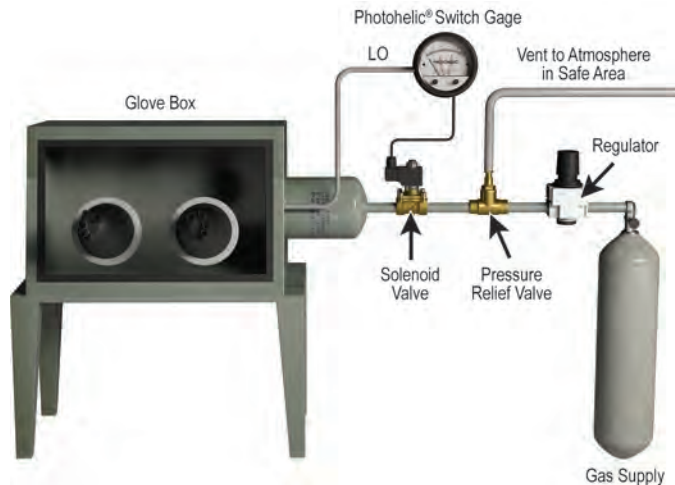

**Zero-center switch/gage controls the inert atmosphere in glove box.**

A controlled inert atmosphere "glove-box" is used in the fields of physical chemistry and metallurgy for handling and welding special or hazardous materials. A Dwyer® Photohelic® differential pressure switch/gage serves as an automatic and readily adjustable pressure control for the helium, argon or nitrogen gas used in the system. The box is first evacuated, then pressurized with the required gas. Therefore, a zero-center Photohelic® switch/gage is used, permitting both pressure and vacuum to be read and controlled by a single gage. Use of the low pressure gage connection (rear chamber of gage) and a Buna-N diaphragm is suggested to minimize leaks from or to the atmosphere.

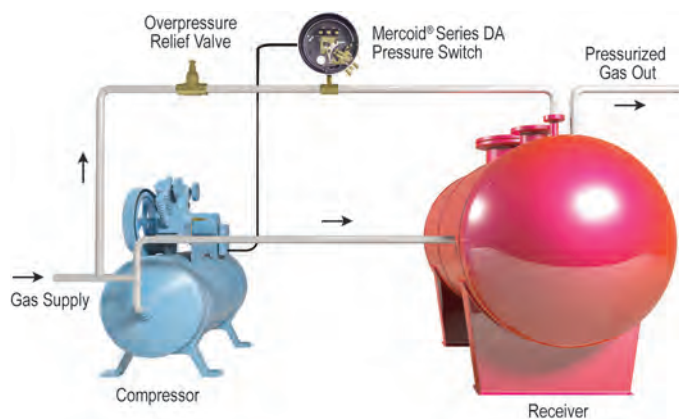

**Mercoird® Series DA pressure switch maintains desired gas pressure in tank.**

Demand for compressed gas varies in this gas line. So a Mercoird® Series DA adjustable deadband pressure switch is included to turn the compressor on at low pressure and off when the maximum pressure is reached.

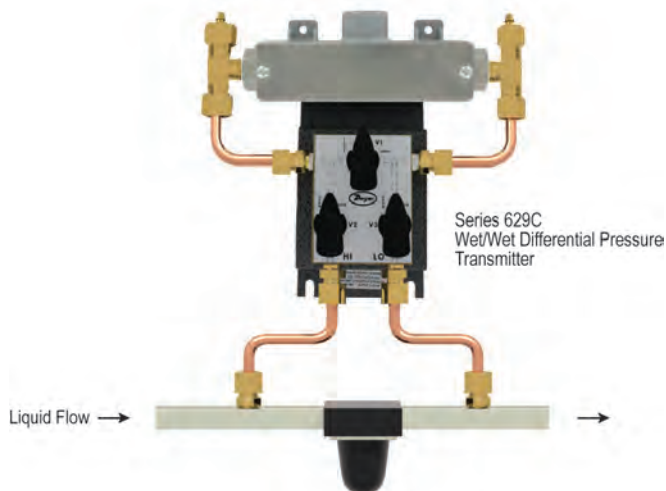

**Three-valve manifold simplifies installation of wet/wet differential pressure transmitter.**

When using differential pressure transmitters in fluid applications, it is essential to periodically make sure that there is no air in the system, as this can cause erroneous readings. Unfortunately, the necessary three-valve bleed system is often expensive and large, making installation difficult and bulky. For this reason, Dwyer Instruments, Inc. offers the 3V option on all 629C Wet/Wet Differential Pressure Transmitters. This compact, lightweight, and economical bleed manifold is shipped factory-installed on the 629C, eliminating the hassle of constructing a custom apparatus. The 629C, when combined with the three-valve option, makes for an ideal setup to monitor hydraulic filter clogging or other fluid pressure sensing applications.

# PRESSURE SENSOR ACCURACY



What is accuracy? The International Electrotechnical Commission (IEC) definition of accuracy is maximum positive and negative deviation from the specified characteristic curve observed in testing a device under specified conditions and by a specified procedure. Unfortunately when it comes to defining accuracy for a pressure sensor it's more complicated. Accuracy has a large effect on the cost of a pressure sensor or even more importantly, the quality or efficiency of the process it is measuring. It is important to understand what factors determine accuracy and what questions to ask when selecting a sensor so that an apples-to-apples comparison can be made instead of apples-to-oranges.

Even though there isn't a defined standard for pressure sensor accuracy there is an IEC standard that defines factors that make-up accuracy. IEC 61298-2 states that accuracy must include Hysteresis, Non-Repeatability and Non-Linearity. Non-Repeatability and Hysteresis are well defined. Hysteresis is the maximum difference in sensor output at a pressure when that pressure is first approached with pressure increasing and then approached with pressure decreasing during a full span pressure cycle. Non-Repeatability is the maximum difference in output when the same pressure is applied, consecutively, under the same conditions and approaching from the same direction.

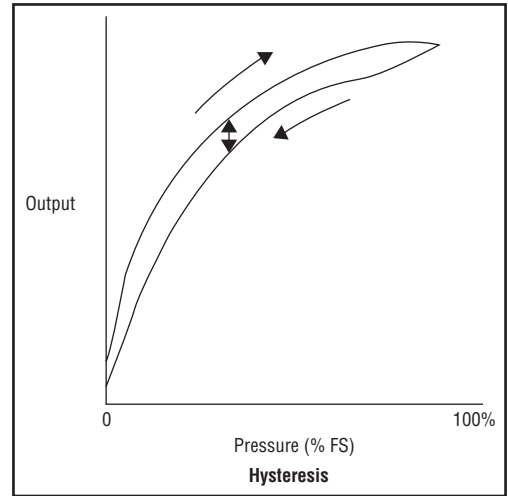
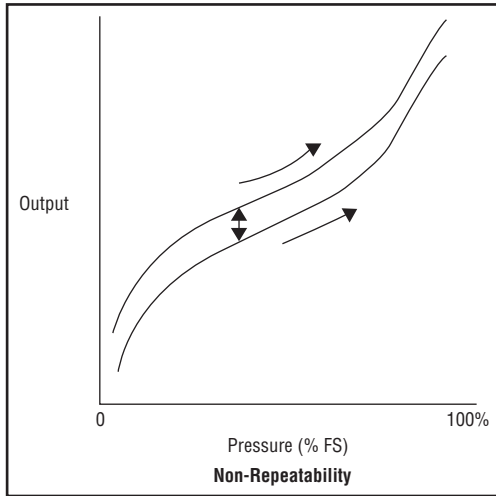

Where manufactures start to differentiate is with Non-Linearity. IEC 61298-2 lists three methods of Non-Linearity, the two most popular methods used by sensor manufactures are the Best Fit Straight Line Non-Linearity and Terminal Point Non-Linearity. Usually the method of non-linearity used will be specified with the sensors accuracy as BFSL or Terminal Point Method. Why is it important to understand the difference between these two methods? Based on the Non-Linearity characteristics of a sensor, it could have two vastly different Non-Linearity percentages. The following diagram shows how the same sensor can have two Non-Linearity percentages.

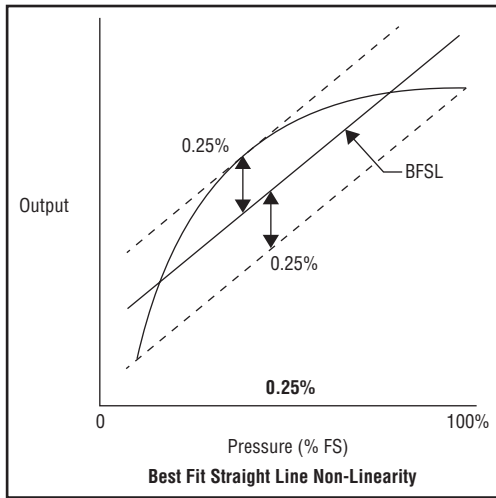

=

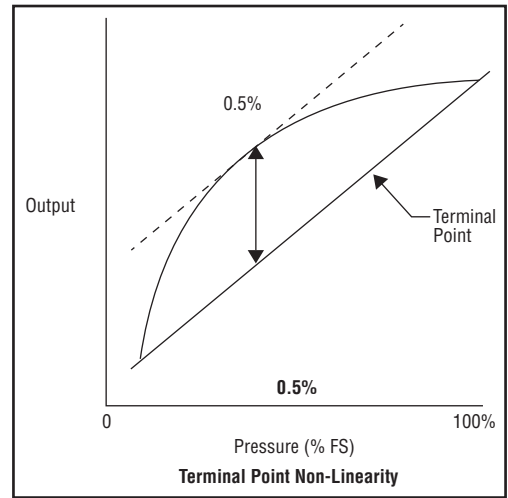

# PRESSURE SENSOR ACCURACY

IEC 61298-2 identifies which factors make up accuracy (Non-Linearity, Non-Repeatability, Hysteresis) but the IEC standard does not specify how these factors are combined into a single accuracy. The methods in which the values are combined have a substantial impact on the total accuracy. Some manufactures simply sum the three factors while others use mathematical equations such as Root of the Sum Squared or Root of the Mean Squared to combine Non-Linearity, Non-Repeatability, and Hysteresis into a total accuracy percentage. The following examples show how the same transmitter can have three accuracy percentages depending on which equation is used.

Non-Linearity – 0.5% BFSL  
 Non-Repeatability – 0.05% FS.  
 Hysteresis – 0.1% FS.

$$RSS = \sqrt{(Non-Linearity)^2 + (Hysteresis)^2 + (Non-Repeatability)^2}$$

$$RSS = \sqrt{(0.50)^2 + (0.10)^2 + (0.05)^2}$$

RSS = 0.51%

**Root of the Sum Squared**

$$RMS = \sqrt{\frac{(Non-Linearity)^2 + (Hysteresis)^2 + (Non-Repeatability)^2}{3}}$$

$$RMS = \sqrt{\frac{(0.50)^2 + (0.10)^2 + (0.05)^2}{3}}$$

RMS = 0.30%

**Root of the Mean Squared**

Sum = Non-Linearity + Hysteresis + Non-Repeatability

Sum = 0.5 + 0.1 + 0.05

Sum = 0.65%

Summed Factors

So why is this important? Accuracy has a price. The cost of a pressure sensor is a function of its accuracy, the more accurate the sensor the more expensive it will be. From a manufacturing point of view, the wrong sensors can cause expensive quality or efficiency problems. That is why it is important to understand how manufacturers calculate accuracy and recognize what parameters to look at when comparing pressure sensors. By understanding how manufacturers calculate accuracy, you will be able to make a more informed decision when evaluating pressure sensors, ensuring the next sensor you select will have the required accuracy at the right price for the application.



# MAGNEHELIC® DIFFERENTIAL PRESSURE GAGES

Indicate Positive, Negative or Differential, Accurate within 1%



Standard Magnehelic® gage



High Accuracy Magnehelic® gage  
Note: Shown with optional -SS bezel

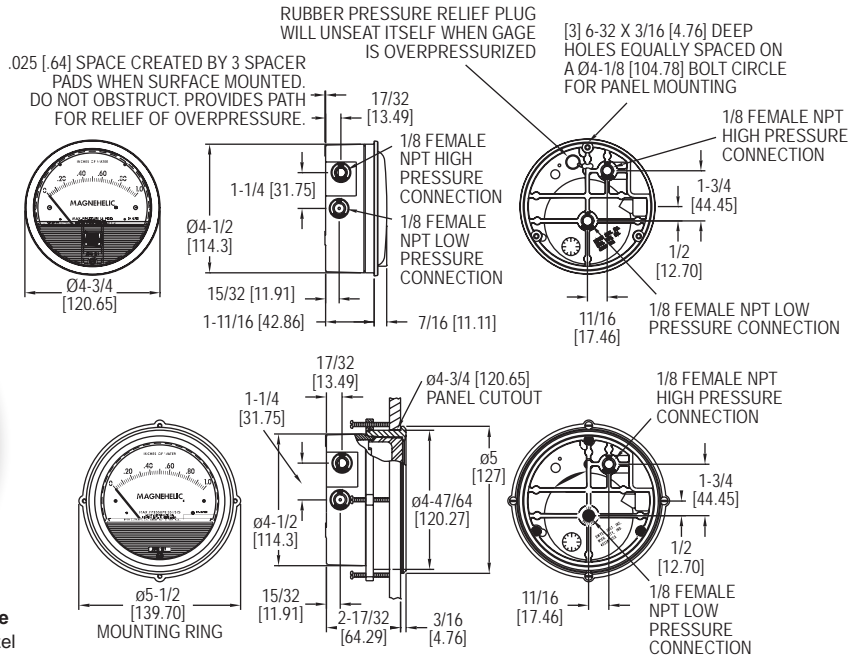

Select the **Series 2000 Magnehelic® Differential Pressure Gages** for a versatile low differential pressure gage with a wide choice of 81 models and 27 options to choose from. Using Dwyer's simple, frictionless Magnehelic® gage movement, it quickly indicates air or non-corrosive gas pressures—either positive, negative (vacuum) or differential. The design resists shock, vibration, over-pressures and is weatherproof to IP67.

Select the -HA High Accuracy Magnehelic® gage option for an accuracy within 1% of full-scale. Also included with the -HA option at no extra cost are a mirrored scale overlay and a 6 point calibration certificate.

**FEATURES/BENEFITS**

- Easy to read gage through undistorted plastic face permits viewing from far away
- Patented design provides quick response to pressure changes means no delay in assessing critical situations
- Durable and rugged housing and high-quality components combine to provide long-service life and minimized down-time
- High accuracy option is twice as accurate as the standard Magnehelic® gage

**APPLICATIONS**

- Filter monitoring
- Air velocity with Dwyer pitot tube
- Blower vacuum monitoring
- Fan pressure indication
- Duct, room or building pressures
- Clean room positive pressure indication

**ACCESSORIES**

Model	Description
A-432	Portable kit; combine carrying case with any Magnehelic® gage of standard range, except high pressure connection. Includes 9 ft (2.7 m) of 3/16" ID rubber tubing, standhang bracket and terminal tube with holder
A-605	Air filter gage accessory kit; adapts any standard Magnehelic® gage for use as an air filter gage. Includes aluminum surface mounting bracket with screws, two 5 ft (1.5 m) lengths of 1/4" aluminum tubing, two static pressure tips and two molded plastic vent valves, integral compression fittings on both tips and valves
A-605B	Air filter gage accessory kit; air filter kit with two plastic open/close valves, two 4" steel static tips, plastic tubing and mounting flange
A-605C	Air filter gage accessory kit; air filter kit with two plastic open/close valves, two plastic static tips, plastic tubing and mounting flange

**SPECIFICATIONS**

**Service:** Air and non-combustible, compatible gases (natural gas option available).  
**Note:** May be used with hydrogen. Order a Buna-N diaphragm. Pressures must be less than 35 psi.

**Wetted Materials:** Consult factory.

**Housing:** Die cast aluminum case and bezel, with acrylic cover. Exterior finish is coated gray to withstand 168 hour salt spray corrosion test.

**Accuracy:** ±2% (-HA model ±1) of FS (±3% (-HA ±1.5%) on -0, -100PA, -125PA, -10MM and ±4% (-HA ±2%) on -00, -60PA, -6MM ranges), throughout range at 70°F (21.1°C).

**Pressure Limits:** -20 in Hg to 15 psig (-0.677 to 1.034 bar); MP option: 35 psig (2.41 bar); HP option: 80 psig (5.52 bar).

**Enclosure Rating:** IP67.

**Overpressure:** Relief plug opens at approximately 25 psig (1.72 bar), standard gages only. ●

**Temperature Limits:** 20 to 140°F\* (-6.67 to 60°C). -20°F (-28°C) with low temperature option.

**Size:** 4" (101.6 mm) diameter dial face.

**Mounting Orientation:** Diaphragm in vertical position. Consult factory for other position orientations.

**Process Connections:** 1/8" female NPT duplicate high and low pressure taps - one pair side and one pair back.

**Weight:** 1 lb 2 oz (510 g), MP & HP 2 lb 2 oz (963 g).

**Standard Accessories:** Two 1/8" NPT plugs for duplicate pressure taps, two 1/8" pipe thread to rubber tubing adapter, and three flush mounting adapters with screws. (Mounting and snap ring retainer substituted for three adapters in MP & HP gage accessories.)

**Agency Approvals:** Meets the technical requirements of EU Directive 2011/65/EU (RoHS II). **Note:** -SP models not RoHS approved.

**Note:** For applications with high cycle rate within gage total pressure rating, next higher rating is recommended. See Medium and High pressure options.

\*Low temperature models available as special options.



A-432

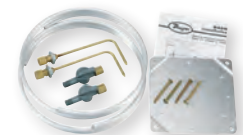

A-605

● Over Protection Note: See page 21 (Series 2000)







# HIGH ACCURACY MAGNEHELIC® DIFFERENTIAL PRESSURE GAGE

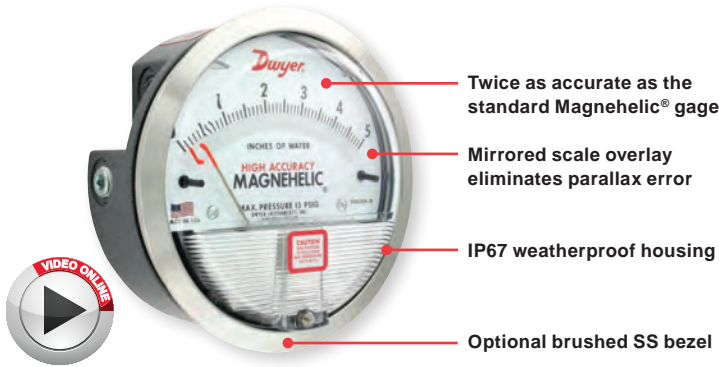

6-point calibration certificate included

OPTIONS - HIGH ACCURACY MAGNEHELIC® GAGE	
To order add suffix:	Description
-HA	High Accuracy Magnehelic® Gage. Accuracy within 1% and weatherproof. Also includes mirrored scale overlay and a six point calibration certificate
-SS	Corrosion resistant brushed 304 stainless steel bezel

Accuracy Specifications: See page 20 (Series 2000)

## ADDITIONAL GAGE OPTIONS



OPTIONS - OTHER OPTIONAL BEZELS	
To order add suffix:	Description
-CB	Chrome bezel option: A chrome plated aluminum bezel for an aesthetically pleasing finish when mounting on metal surfaces such as control panels.
-SB	Stainless steel bezel option: 304 stainless steel electro polished Ra 16 finished bezel.
-SS	Corrosion resistant brushed 304 stainless steel bezel



LED set point indicator

Adjustable signal flag

OPTIONS - LED SET POINT INDICATOR	
To order add suffix:	Description
-SP	Bright red LED on right scale shows when set point is reached. Field adjustable from gage face, unit operates on 12-24 VDC. Set point indicator option comes with medium pressure (MP) bezel.

Note: 4-13/16" hole for flush mounting.



Transparent overlay

Mirrored scale overlay

OPTIONS - ADJUSTABLE SIGNAL FLAG	
To order add suffix:	Description
-ASF	Integral with plastic gage cover. Available for most models except those with medium or high pressure construction. Can be ordered with gage or separate.

OPTIONS - TRANSPARENT OVERLAYS	
To order add suffix:	Description
-G	Green (to highlight and emphasize critical pressures)
-R	Red (to highlight and emphasize critical pressures)
-Y	Yellow (to highlight and emphasize critical pressures)



Integrated mounting plate

OPTIONS - MIRRORED SCALE OVERLAY	
To order add suffix:	Description
-M	A mirrored scale overlay is also available to assist in reducing parallax error.

OPTIONS - INTEGRATED MOUNTING PLATE	
To order add suffix:	Description
-AHU1	Furnished with attached surface mounting plate
-AHU2	Furnished with attached surface mounting plate and including A-481 installer kit (2 plastic static pressure tips and 7' of PVC tubing)



OPTIONS - FOR HIGH STATE PRESSURE APPLICATIONS	
To order add suffix:	Description
-HP	High pressure option: for pressures to 80 psig
-MP	Medium pressure option: for pressures to 35 psig

OPTIONS	
To order add suffix:	Description
-FC	Factory calibration certificate
-LT	Low temperatures to -20°F (-28°C)
-NIST	NIST traceable calibration certificate

# MAGNEHELIC® GAGE MOUNTING ACCESSORIES



A-610



A-369



A-300

Pressure reference port



A-464

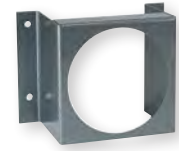

A-299



A-286



A-368



A-371

A single case size is used for most models of Magnehelic® gages. They can be flush or surface mounted with standard hardware supplied. Complete mounting and connection fittings plus instructions are furnished with each instrument. A 4-9/16" hole is required for flush panel mounting.

Flush mounting is easily accomplished with the new A-300 Flush Mounting bracket. This bracket provides a solution to quickly and conveniently flush mount the Magnehelic® gage. The A-300 is ideal for mounting the Magnehelic® gage on control panel doors.

The A-368 is a simple bracket for quickly surface mounting the Magnehelic® gage. After securing the Magnehelic® gage to the A-368 bracket, mount the bracket on any flat surface.

The A-369 allows the Magnehelic® gage to be easily carried to locations where pressure readings need to be taken. The A-369 can stand on its own or hang on a nail or hook.

ACCESSORIES	
Model	Description
A-610	Pipe mounting kit for installing on 1-1/4" to 2" horizontal or vertical pipe
A-286	Magnehelic® gage panel mounting flange
A-369	Stand-hang bracket, aluminum, for Magnehelic® gage
A-300	Flush mounting bracket
A-464	Flush mount kit for Magnehelic® gage
A-368	Surface mounting plate, aluminum, for Magnehelic® gage
A-299	Mounting bracket, flush mount for Magnehelic® gage, bracket is then surface mounted, steel with gray hammerloid epoxy finish
A-371	Surface mounting bracket, use with medium pressure (-MP) or high pressure (-HP) models only

## SERIES A-320

# INSTRUMENT ENCLOSURES

Protects Various Instruments



A-320-A1



A-320-B1



A-320-BC



A-320-A-SS



A-320-B-SS

The **Series A-320 Instrument Enclosures** protect instruments in all applications. The enclosures, available in plastic and stainless steel, fit a variety of gages including the Series 605 transmitter, DM-2000, 3000MR/MRS and DH3. All models include silicone tubing, Banjo fittings, and threaded pressure connections pre-installed. The threaded pressure connections allow the user to easily change the connection type through the use of fittings or adapters. This modification can be implemented to allow connection to a wide variety of plastic or metal tubing.

SPECIFICATIONS	
<b>Housing Material:</b>	ABS plastic or 304 SS.
<b>Process Connection:</b>	1/8" female NPT (-SS models: 1/8" BSPT).
<b>Enclosure Rating:</b>	Plastic models: IP66.
<b>Weight:</b>	A-320-A1: 1.1 lb (0.5 kg); A-320-B1: 1.4 lb (0.65 kg); A-320-BC: 1.4 lb (0.65 kg); A-320-A-SS: 2.3 lb (1.05kg); A-320-B-SS: 3.0 lb (1.35 kg).

MODEL CHART	
Model	Description
A-320-A1*	2000 Magnehelic® gage, DM-2000 differential pressure transmitter
A-320-B1**	3000MR/MRS Photohelic® switch/gage, Series 605 Magnehelic® differential pressure transmitter, DH3 DigiHelic® pressure controller, 2000 Magnehelic® gage with medium and high pressure options
A-320-BC	2000 Magnehelic® gage, DM-1000 DigiMag® digital differential pressure gage, DM-2000 differential pressure transmitter, instruments with backwards compatible bezel option
A-320-A-SS	2000 Magnehelic® gage
A-320-B-SS	2000 Magnehelic® gage, DM-2000 differential pressure transmitter

\*DM-2000 must be mounted horizontally in A-320-A1 enclosure.  
 \*\*For DH3 to fit on A-320-B1 the casing on the electrical plug must be removed.

ACCESSORIES	
Model	Description
A-339-SS	1/8" male BSPT to 3/16" hose barb



# ATEX/IECEX APPROVED SERIES 2000 MAGNEHELIC® DIFFERENTIAL PRESSURE GAGE

Magnehelic® Gage in Flame-Proof ATEX/IECEX Enclosure

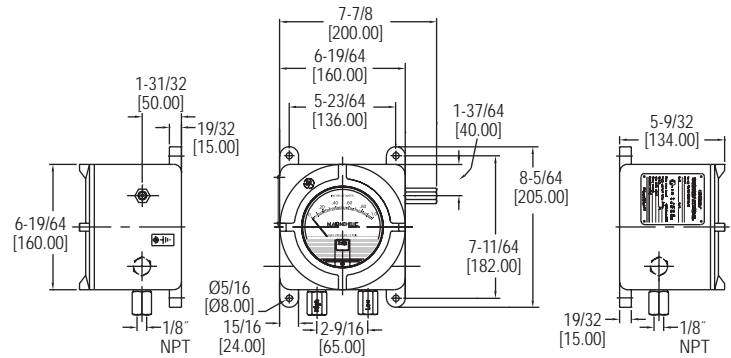

The Series AT22000 ATEX/IECEX Approved Series 2000 Magnehelic® Differential Pressure Gage combines the popular Magnehelic® line with a flameproof enclosure to extend usage to hazardous locations. This gage can indicate positive, negative or differential pressures and is accurate within 2%.

**FEATURES/BENEFITS**

- ATEX/IECEX housing provides all the capabilities and value of the Magnehelic® in a flame & explosion proof enclosure
- Quick response to pressure changes means no delay in assessing critical situations
- Durable and rugged housing and high-quality components combined provides long-service life and minimized down-time
- High impact strength and high temperature rated for applications where hazardous environments exist

**APPLICATIONS**

- Fan and blower pressures
- Filter resistance
- Air velocity
- Furnace draft
- Liquid levels with bubbler systems
- Pressure in fluid amplifier or fluidic systems

**Attention:** Check local safety rules and warnings on unit and manual for a correct use of the instrument in hazardous area.

**SPECIFICATIONS**

**Service:** Air and non-combustible, compatible gases.  
**Wetted Materials:** Consult factory.  
**Magnehelic® Housing:** Die cast aluminum case & bezel with acrylic cover; Exterior finish is coated gray to withstand 168 hour salt spray corrosion test.  
**Housing Material:** Aluminum.  
**Finishing:** Texture epoxy coat RAL7038.  
**Accuracy:** ±2% of FS (±3% on -0, -100PA, -125PA, -10MM and ±4% on -00, -60PA, -6MM ranges), throughout range at 70°F (21.1°C).  
**Pressure Limits:** -20 in Hg to 15 psig (-0.677 bar to 1.034 bar); MP option; 35 psig (2.41 bar), HP option; 80 psig (5.52 bar).  
**Overpressure:** Relief plug opens at approximately 25 psig (1.72 bar), standard gages only. **Ⓢ**  
**Temperature Limits:** 20 to 140°F (-6.67 to 60°C); Low temperature option: -20°F (-28.8°C) (**Note:** Product temperature limits are less than case limits).  
**Mounting Orientation:** Diaphragm in vertical position.  
**Enclosure Rating:** IP66. IP65 with option OPV, overpressure relief valve.  
**Process Connections:** 1/8" NPT female brass (SS optional). In presence of acetylene it is necessary to use SS.  
**Weight:** 8.6 lb (3.9 kg).  
**ATEX Certificate:** BV1 14ATEX0072.  
**Agency Approvals:** ATEX Compliant **CE** 1370 **Ex** II 2G Ex d IIC T6 Gb / II 2D Ex tb IIIC T85°C Db, -60°CsTamb+60°C IECEx Compliant: Ex d IIC T6 Gb / Ex tb IIIC T85°C Db.

RANGE CHART					
Model	Range in w.c.	Model	Range in w.c.	Model	Range in w.c.
2000-00N	.05 to 0 to .2	2006	0 to 6.0	2040	0 to 40
2000-00	0 to .25	2008	0 to 8.0	2050	0 to 50
2000-0	0 to .50	2010	0 to 10	2060	0 to 60
2001	0 to 1.0	2012	0 to 12	2080	0 to 80
2002	0 to 2.0	2015	0 to 15	2100	0 to 100
2003	0 to 3.0	2020	0 to 20	2120	0 to 120
2004	0 to 4.0	2025	0 to 25	2150	0 to 150
2005	0 to 5.0	2030	0 to 30	2160	0 to 160

MODEL CHART										
Example	AT2	2001	-X	X	-A	O	1	X	T2	AT22001-XX-AO1XT2
Housing	AT2									ATEX/IECEX approved Series 2000 Magnehelic® differential pressure gage
Range		2XXX								Specify range by using Magnehelic® model number. See range chart.
Pressure Rating			X MP HP							Standard from -20 in Hg to 15 psig static pressure Medium pressure-max. static 35 psig High pressure-max. static 80 psig
Temperature Rating				X LT						Standard temperature limits -6.67 to 60°C Low temperature limit to -28.8°C
Housing Material					A					Aluminum
Cover						O				Glass cover
Process Connection							1 2			1/8" NPT female brass ports 1/8" NPT female SS ports
Overpressure Plug								X OPV		Standard without overpressure relief valve Overpressure relief valve Material same as ports
Tag									T2	SS information label

For other engineering unit ranges contact the factory.

USA: California Proposition 65  
 ⚠WARNING: Cancer and Reproductive Harm - www.P65Warnings.ca.gov

Ⓢ Over Protection Note: See page 21 (Series 2000)



# DIGIMAG<sup>®</sup> DIGITAL DIFFERENTIAL PRESSURE AND FLOW GAGE

24 Volt or Battery Powered, Fits in Magnehelic<sup>®</sup> Gage Cut-Out

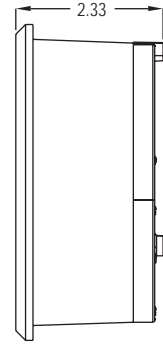
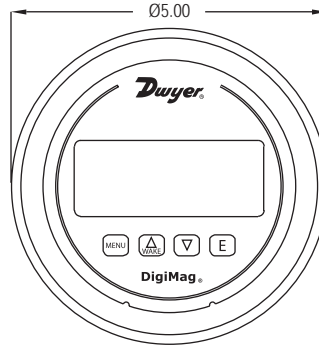

The **Series DM-1000 DigiMag<sup>®</sup> Digital Differential Pressure and Flow Gage** monitors the pressure of air and compatible gases just as its famous analog predecessor the Magnehelic<sup>®</sup> differential pressure gage. All models are factory calibrated to specific ranges. The 4-digit LCD can display readings in common English and metric units so conversions are not necessary. The simplified four button operation reduces set up time and simplifies calibration with its digital push-button zero and span.

#### FEATURES/BENEFITS

- Field programmed reduces installation time
- User selectable parameters for pressure, air velocity or flow permits same device for multiple applications
- Specialized filter set point for alerts when maintenance is due
- Security levels permit matches the correct access to right skill
- Power versatility works with 9-24 VDC or 9 V battery allows deployment in a variety of spaces wired or not

#### APPLICATIONS

- Filter monitoring
- Air velocity or flow
- Blower vacuum monitoring
- Fan pressure indication
- Duct, room or building pressures
- Clean room positive pressure indication

#### ACCESSORIES

Model	Description
A-300	Flat flush mounting bracket
A-286	4-1/2" gage panel mounting flange
A-489	4" straight static pressure tip with flange
A-480	Plastic static pressure tip

#### SPECIFICATIONS

**Service:** Air and non-combustible, compatible gases.  
**Wetted Materials:** Consult factory.  
**Housing Materials:** Glass filled plastic.  
**Accuracy:** ±1% FS including linearity, hysteresis and repeatability; ±2% FS for ranges 1 in w.c. and below.  
**Temperature Limits:** 0 to 140°F (-18 to 60°C).  
**Compensated Temperature Limits:** 32 to 122°F (0 to 50°C).  
**Long Term Stability:** ±1% FS per year.  
**Thermal Effect:** ±0.05% FS/°F typ.; ±0.10% FS/°F for ranges 1 in w.c. and below.  
**Display:** 4-digit LCD (digits: 0.60H x 0.33W).  
**Display Update:** Selectable for 1 second to 10 minutes or update only from button push.  
**Pressure Limits:** Normal and bi-directional ranges 5 in w.c. and lower = 2 psi (13.7 kPa); Normal and bi-directional ranges 10 in w.c. and higher = 11 psi (75 KPa).  
**Selectable Engineering Units:** in w.c., psi, kPa, Pa, mm w.c., mBar, in Hg, mm Hg, FS (0-100%).  
**Power Requirements:** 9 V alkaline battery, included, user replaceable or external power supply 9-24 VDC.  
**Battery Service Life:** Battery life depending on the display update setting: 150 hours (typical) if display update = 1 second; 9 month (typical) if display update = 10 minutes; 1.5 years (typical) if display update is disabled. Battery may last up to four times longer when using lithium-based battery ULTRALIFE U9VL-J.  
**Current Consumption:** 5 mA max.  
**Electrical Connections:** Removable terminal block for 16 to 26 AWG.  
**Electrical Entry:** Cable gland for 0.114 to 0.250" (2.9 to 6.4 mm) diameter cable.  
**Process Connections:** 1/8" (3 mm) ID tubing.  
**Enclosure Rating:** NEMA 4X (IP66).  
**Weight:** 1.18 lb (535 g).  
**Size:** 5" (127 mm) OD front face.  
**Agency Approvals:** CE.

#### MODEL CHART

Model	Range									Resolution in w.c.
	in w.c.	psi	kPa	Pa	mbar	mm w.c.	in Hg	mm Hg	% of FS	
DM-1102	0.250	—	0.062	62.20	0.622	6.35	—	0.467	100.0	0.001
DM-1103	0.500	—	0.124	124.5	1.245	12.70	—	0.934	100.0	0.001
DM-1104	1.000	—	0.249	249.1	2.492	25.40	—	1.868	100.0	0.001
DM-1105	2.000	—	0.498	498.2	4.982	50.80	—	3.736	100.0	0.001
DM-1107	5.000	0.181	1.245	1245	12.45	127.0	0.368	9.34	100.0	0.002
DM-1108	10.00	0.361	2.491	2491	24.91	254.0	0.736	18.68	100.0	0.010
DM-1109	15.00	0.543	3.738	3738	37.38	381.0	1.104	28.02	100.0	0.010
DM-1110	25.00	0.903	6.227	6227	62.27	635.0	1.839	46.71	100.0	0.010
DM-1111	50.00	1.806	12.45	—	124.5	1270	3.678	93.42	100.0	0.020
DM-1112	100.0	3.613	24.91	—	249.1	2540	7.355	186.8	100.0	0.100

Contact the factory for available bi-directional ranges from ±0.25 to ±10 in w.c.

**Note:** For air flow models change -11XX to -12XX.

#### OPTIONS

To order add suffix:	Description
-NIST	NIST traceable calibration certificate
<b>Example:</b> DM-1103-NIST	

Process Tubing Options: See page 455 (Gage Tubing Accessories)

**Dwyer**

SERIES 2-5000

**MINIHELIC® II DIFFERENTIAL PRESSURE GAGE**

Combining High Accuracy, Compactness, Dependability, and Low Cost

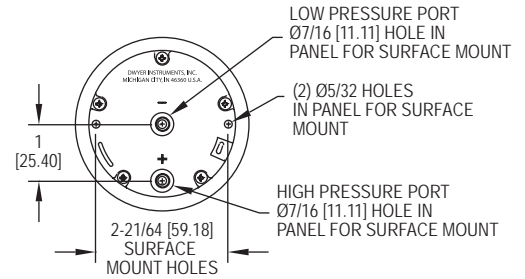
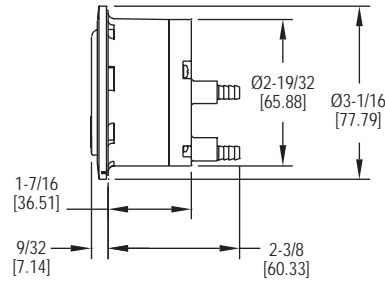

Combining clean design, small size and low cost with enough accuracy for all but the most demanding applications our **Series 2-5000 MiniHelic® II Differential Pressure Gage** offers the latest in design features for a dial type differential pressure gage. It is our most compact gage but is easy to read and can safely operate at total pressures up to 30 psig.

**FEATURES/BENEFITS**

- Removable lens and rear-housing provides easy, cost-effective servicing
- Accuracy and value provides an excellent solution for OEM and user applications
- Durable housing materials make it well-suited for rough environments and total high pressure

**APPLICATIONS**

- Room positive pressure sensing
- Cabinet air-purging
- Medical respiratory equipment
- Air samplers
- Electronic air cooling systems
- Laminar flow hoods
- Local indication on filter status
- Face velocity on fume hood
- Duct pressures

**SPECIFICATIONS**

**Service:** Air and compatible gases.

**Wetted Materials:** Consult factory.

**Housing:** Glass filled nylon; polycarbonate lens.

**Accuracy:** ±5% of FS at 70°F (21.1°C).

**Pressure Limits:** 30 psig (2.067 bar) continuous to either pressure connection.

**Temperature Limits:** 20 to 120°F (-6.67 to 48.9°C).

**Size:** 2-1/16" (52.39 mm) diameter dial face.

**Mounting Orientation:** Diaphragm in vertical position. Consult factory for other position orientations.

**Process Connections:** Barbed, for 3/16" ID tubing (standard); 1/8" male NPT (optional).

**Weight:** 6 oz (170.1 g).

**Agency Approvals:** Meets the technical requirements of EU Directive 2011/65/EU (RoHS II).

**Caution:** For use only with air or compatible non-corrosive gases.

# MINIHELIC® II DIFFERENTIAL PRESSURE GAGE

Combining High Accuracy, Compactness, Dependability, and Low Cost

**Housing** is molded from strong mineral and glass filled nylon.

**Pointer stops** of molded rubber prevent pointer over-travel without damage.

**Full view lens** is removable and molded of acrylic.

**Aluminum scale** litho-printed black on white, enhances readability.

**Red tipped aluminum pointer**, rigidly mounted to helix is easy to see.

**Wishbone assembly** provides mounting for helix, helix bearings, and pointer shaft.

**Jewel bearings** provide virtually friction-free helix motion.

**Helix** is free to rotate in jewel bearings. It aligns with magnetic field of magnet to transmit pressure indications to pointer.

**Zero adjustment screw**, located behind the removable lens, eliminates tampering.

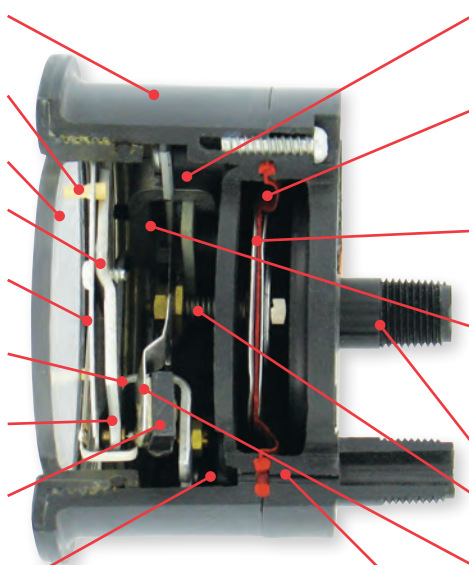

**Range spring calibration clamp** fixes live length of spring for proper gage calibration and is factory set and sealed.

**Silicone rubber diaphragm** allows accurate response to a broad range of temperatures and at extremely low pressure. Incorporates blow out area for overpressure protection.

**Diaphragm support plates** of lightweight aluminum on each side of the diaphragm minimize position or attitude sensitivity and help define pressure area.

**Flat leaf range spring** reacts to pressure on the diaphragm. Live length is adjustable for calibration. Small amplitude of motion minimizes inaccuracies and assures long life.

**Low pressure tap** connects to rear chamber.

**Coil spring link** provides a resilient connection between the diaphragm and the range spring.

**Ceramic magnet** mounted on a molded bracket at the end of the range spring rotates the helix without direct mechanical linkage.

**High pressure tap** connects with the front chamber through passageway in the plastic case and a sealing ring molded into the edge of the diaphragm.

MODEL CHART			
Model	Range, Inches of Water	Model	Range, MM of Water
2-5000-0	0-0.5	2-5000-25MM	0-25
2-5001	0-1.0	2-5000-50MM	0-50
2-5002	0-2.0	2-5000-100MM	0-100
2-5003	0-3.0		
2-5005	0-5.0	<b>Model</b>	<b>Range, Pascals</b>
2-5010	0-10	2-5000-125PA	0-125
2-5020	0-20	2-5000-250PA	0-250
2-5040	0-40	2-5000-500PA	0-500
2-5060	0-60		
2-5100	0-100	<b>Model</b>	<b>Range, kPa</b>
		2-5000-1KPA	0-1
		2-5000-3KPA	0-3
<b>Model</b>	<b>Range, PSI</b>		
2-5205	0-5		

OPTIONS	
To order add suffix:	Description
-NPT	1/8" male NPT connections
<b>Example:</b> 2-5001-NPT	
-BB	Bottom barbed surface mount
<b>Example:</b> 2-5001-BB	
-NIST	NIST traceable calibration certificate
<b>Example:</b> 2-5001-NIST	
-FC	Factory calibration certificate
<b>Example:</b> 2-5001-FC	

ACCESSORIES	
Model	Description
A-302F-A	303 SS static pressure tip with mounting flange; for 3/16" ID rubber or plastic tubing; 4" insertion depth; includes mounting screws
A-434	Portable kit
A-489	4" straight static pressure tip with flange
A-497	Surface mounting bracket
A-609	Air filter kit
A-480	Plastic static pressure tip

### SURFACE MOUNTING



Optional surface mounting with back mounting plate allows for quick installation to any surface. Process connections are barbed and point downwards. Add -BB for bottom barbed surface mount option.



### PANEL MOUNTING



Mounting hardware is supplied with the Minihelic® II gage for panel mounting through a single hole, 2-5/8" (67 mm) in diameter. Panel thickness up to 1/2" (13 mm) can be accommodated with the hardware supplied. If necessary, surface mounting of the gage can be accomplished by means of two 4-40 screws into the tapped mounting bracket stud holes in the rear of the gage. Surface mounting requires clearance holes in the panel for the two pressure taps.

Process Tubing Options: See page 455 (Gage Tubing Accessories)

# MARK II MOLDED PLASTIC MANOMETERS

## 3% Accuracy For Stationary And Portable Applications



Mark II Model No. 25 inclined-vertical manometer.  
(shown with optional A-612 portable stand)



Mark II Model No. 40-1 inclined manometer

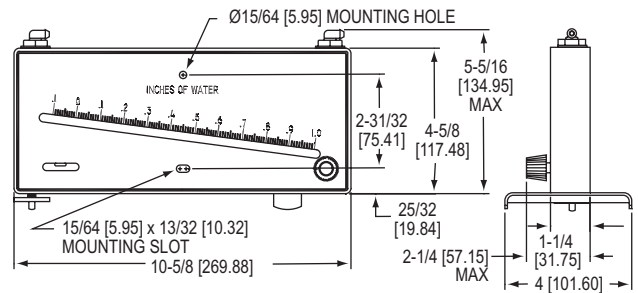
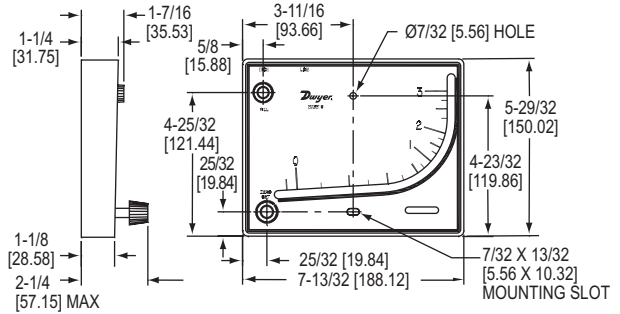

**Series Mark II Molded Plastic Manometers** are of the inclined and inclined-vertical types. The curved inclined-vertical tube of the Model 25 gage provides higher ranges with more easily read increments at low readings. The Model 25 is excellent for general purpose work. The Model 40 inclined gage provides linear calibration and excellent resolution throughout its range. The Model 40 is ideally suited for air velocity and air filter gage applications. Both gage types are capable of pressure measurements above and below atmospheric as well as differential pressure measurements. Included with each Mark II manometer are two tubing connectors for 1/8" pipe or sheet metal ducts, two mounting screws, 1 ounce bottle of indicating fluid, red and green pointer flags and complete instructions.

The Model 25 also includes 8' of flexible double column plastic tubing. Portable operation of the Model 25 is made possible by the use of the optional A-612 portable stand. A short piece of tubing can be slipped over the Model 25 pressure connections to contain the gage fluid in transit.

The Model 40 contains two 4-1/2' lengths of clear plastic tubing, a plastic swing-out stand and leveling screw for portable operation. It also features convenient rapid shutoff pressure connections and integral overpressure safety traps.

**FEATURES/BENEFITS**

- Broad ranging in easy to read calibrated increments
- Gages ideally suited for general measurements and specific air applications
- Compact, stationary or portable device, make it a simple to use tool for pressure measurement in OEM or user applications

**APPLICATIONS**

- Paint booths
- Air velocity measurement
- Air filter gage

**OEM SPECIALS**

All Dwyer® Mark II molded plastic manometers can be supplied in OEM quantities with your name or special graphics and scales.

**ACCESSORIES**

Model	Description
A-612	Portable stand
A-606	Air filter kit
A-480	Plastic static pressure tip
A-489	4" straight static pressure tip with flange

**SPECIFICATIONS**

**INCLINED/VERTICAL**

**Accuracy:** ±3% FS.  
**Temperature Limits:** 140°F (60°C).  
**Pressure Limits:** 10 psi (70 kPa).  
**Weight:** 1.04 lb (472 g).  
**Agency Approvals:** Meets the technical requirements of EU Directive 2011/65/EU (RoHS II).

**INCLINED**

**Accuracy:** ±3% FS.  
**Temperature Limits:** 150°F (65°C).  
**Pressure Limits:** 15 psi (100 kPa).  
**Scale Length:** Approx. 8-1/4" (21 cm).  
**Weight:** 1.23 lb (558 g).  
**Agency Approvals:** Meets the technical requirements of EU Directive 2011/65/EU (RoHS II).

**MODEL CHART**

Model	Range	Fluid Used
Mark II 25	0-3 in w.c	Red fluid, .826 s.g.
Mark II 26	0-7 in w.c.	Blue oil, 1.91 s.g.
Mark II 27*	0-7000 fpm	Red fluid, .826 s.g.
Mark II MM-80	0-80 mm w.c.	Red fluid, .826 s.g.
Mark II M-700PA	10-0-700 Pa	Red fluid, .826 s.g.
Mark II 40-1	.1-0-1.0 in w.c.	Red fluid, .826 s.g.
Mark II 40-25MM	0-26 mm w.c.	Red fluid, .826 s.g.
Mark II 40-250PA	10-0-250 Pa	Red fluid, .826 s.g.
Mark II 41-60MM	0-60 mm w.c.	Blue oil, 1.91 s.g.
Mark II 41-600PA	20-0-600 Pa	Blue oil, 1.91 s.g.

\*Require Pitot tube at additional cost. ①

① Pitot tube: See pages 186-188 (Test & Data section)

Process Tubing Options: See page 455 (Gage Tubing Accessories)



# INCLINED MANOMETER AIR FILTER GAGES

Precision Machined, Solid Acrylic Plastic Gages, Accurate To  $\pm 1\%$  Of Full-Scale

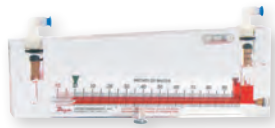

Model 250.5-AF



Model 452-AF

Dwyer® Durablock® Series 250-AF Inclined Manometer Air Filter Gages are precision machined 1" thick solid acrylic plastic, virtually unbreakable and free of distortion. The fluid bore is precision drilled to  $\pm .0002"$  to assure life-long accuracy. A glass spirit level is built into the body and encapsulated to prevent damage or tampering. The scale is mirror polished chrome plated brass to assure parallax free reading by alignment of the meniscus with its reflection. Safety traps are incorporated in the body to prevent loss of fluid due to pressure surges. Red and green signal flags indicate clearly when a filter change is necessary. Gages are suitable for use in ambient temperatures of -20 to 150°F. Connection fittings are positively sealed but easily removed for zeroing or addition of fluid.

### FEATURES/BENEFITS

- High-accuracy and easy to use make it a dependable device for many years of service
- Easy to read polished inclined scale allows pressure minute pressure differences to be read
- No moving parts mean no calibration or nothing to wear out

### APPLICATIONS

- Air filter gage

ACCESSORIES	
Model	Description
A-310B	3-way vent valve, 1/8" NPT to 1/4" metal tubing, 10 psi rating
A-317	Gage connector, 1/8" pipe thread opening, less OD thread, for slip fit in 3/4" diameter opening in Series 250-AF gages

▲ Economy Model 452-AF is similar to the 250 Series except they are not equipped with over pressure traps. Two A-324 1/4" compression fittings are included with each gage but not shown. Bodies are of 5/8" thick acrylic and scales are mirror polished, epoxy coated aluminum.

MODEL CHART				
Model	Range: Water Column	Minor Divisions	Scale Length Inclined (Inches)	Overall Size (Inches)
250-AF	.10-0-1.0"	.02"	5-1/2	8-1/2 x 4-1/8 x 1
250.5-AF	.10-0-1.0"	.01"	8	11-3/8 x 4 x 1
251-AF	.05-0-.50"	.01"	5-1/2	8-1/4 x 3-3/8 x 1
252-AF	.20-0-2.0"	.02"	8	11-1/8 x 6-1/2 x 1
452-AF▲	0-2"	.02"	8	11 x 4 x 5/8

▲ 2 PSI maximum working pressure

USA: California Proposition 65

▲WARNING: Cancer and Reproductive Harm - www.P65Warnings.ca.gov

## SERIES 200 & 300

# DURABLOCK® SOLID PLASTIC STATIONARY GAGES

Suitable for Total Pressures Up to 100 psig, Temperatures Up to 150°F, Accuracy  $\pm 2\%$  of Full-Scale (1% on Models 215, 244, 246 Only)

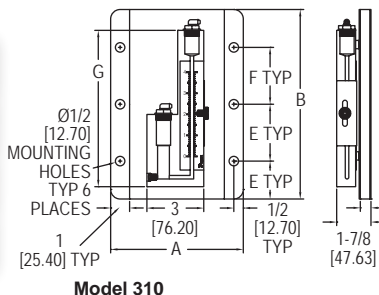

Model 310

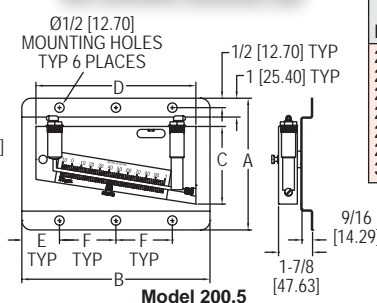

Model 200.5

Model	Dimensions, Inches						
	A	B	C	D	E	F	G
200.5	7	13	3-15/16	11-3/8	2	4-1/2	-
202.5	9	13	5-5/8	12	2	4-1/2	-
209	9	13	7	11-1/4	2	4-1/2	-
215	7	10	3-1/16	9-1/2	2	3	-
244	11	16-1/2	3-1/8	15-5/8	4	8-1/2	-
246	13-1/2	23	11	22	4	15	-
310	7	16	-	-	4	4	15-1/4

Dwyer® Series 200 & 300 Durablock® Solid Plastic Stationary Gages, or draft gages, are offered in inclined and vertical (well-type) styles for highly accurate laboratory or general industrial service, for measurement of low range gas and air pressures, positive, negative or differential. To assure the accuracy required in instruments of this type, all machining of bores and wells is to the highest standards of precision backed by Dwyer's years of experience in the fabrications of acrylic instruments.

### FEATURES/BENEFITS

- High-accuracy measurement of low range gas and air pressure suitable for laboratory or general industry
- Precision built assures device meets the highest standards
- No moving parts mean no calibration or nothing to wear out
- Over-pressure trap prevents liquid from being expelled from gage, preventing disruption of operation

### APPLICATIONS

- Low pressure laboratory and industrial service applications



Exclusive Dwyer® over-pressure safety traps assure that over range pressures whether gradual or a sudden surge will not force the liquid out of the gage. Over-pressures simply raise the float, force the O-ring over the opening and seal the fluid in the gage. When pressure is reduced, the float drops down releasing the O-ring safety trap which allows the gage to continue operation.

MODEL CHART				
Incline Type Model	Range Inches of Water	Minor Scale Divisions	Scale Length	Weight lb-oz
200.5	.10-0-1.0	.01	8-1/4	3-11
202.5	.20-0-2.0	.01	8-3/4	4-7
209	.20-0-3.0	.02	8-3/4	4-11
215	.05-0-.25	.005	6	2-14
244	0-4	.02	13-1/4	9-11
246	0-6	.02	20	13-14
Vertical or Well-Type Model	Range Inches of Water	Minor Scale Divisions	Scale Length	Weight lb-oz
310	0-10	.10	11-1/8	3-10

Note: Model 200.5 replaces Model 200. Model 202.5 replaces Model 202.

OPTIONS	
To order add suffix:	Description
-NIST	NIST traceable calibration certificate
Example: 244-NIST	

# DURABLOCK® INCLINED-VERTICAL MANOMETERS

Accuracy To  $\pm 0.25\%$



Inclined-vertical manometer  
single column



Inclined-vertical manometer  
double column

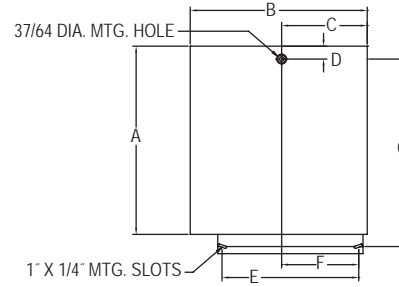

RANGES AND DIMENSIONS - SUITABLE FOR TOTAL PRESSURE UP TO 100 PSIG, TEMPERATURES UP TO 150°F															
Model	Description	Inclined Range Inches of Water	Inclined Minor Div.	Length of Inclined Scale	Vertical Range Inches of Water	Vertical Minor Div.	Length of Vertical Scale	Dimensions							Weight lb-oz
								A	B	C	D	E	F	G	
424-10	Single column	0-2.0	.01	20"	2.1-10	.10	9"	16-1/2"	25-1/4"	12-5/8"	1"	10-1/2"	5-3/8"	16"	22-12
421-5	Single column	0-1.0	.01	6-1/2"	1.1-5	.10	4-5/8"	9-7/8"	9-5/8"	4-7/8"	5/8"	6-1/2"	3-1/4"	9-7/8"	4-12
421-10	Single column	0-1.0	.01	6-1/2"	1.1-10	.10	10-1/8"	15-1/2"	9-5/8"	4-7/8"	5/8"	6-1/2"	3-1/4"	15-1/2"	6-10
422-5	Double column	0-1.0	.01	6-1/2"	1.1-5	.10	4-5/8"	10-1/2"	11-1/2"	5-1/8"	5/8"	6-1/2"	3-1/4"	10-1/2"	6-10
422-10	Double column	0-1.0	.01	6-1/2"	1.1-10	.10	10-1/8"	16-1/8"	11-1/2"	5-1/8"	5/8"	6-1/2"	3-1/4"	16-1/8"	10-13

\*Single column metric-ranges and divisions in millimeters.

Dwyer® Series 420 Durablock® Inclined-Vertical Manometers are extremely accurate instruments designed and made especially for precision measurement of low differential pressures in laboratory and test applications. The inclined range bore has a length of 20" to provide ample multiplication of indicating fluid movement in this critical lower part of the range.

**FEATURES/BENEFITS**

- High-accuracy measurement of low range gas and air pressure suitable for laboratory and test applications
- Long bore length provides ample room for fluid movement for low range sensing
- Precision built to assure device meets the highest standards

**APPLICATIONS**

- Low pressure laboratory and test applications

**ACCESSORIES - STANDARD**

**Description**

Include two 1 oz bottles of .826 red gage fluid (1.91 blue gage oil for models 421-23 and 422-23), rapid shut-off type "a" connections, two 3 ft lengths of clear plastic tubing and two 1/8" NPT tubing adapters — two sets for double column models.

**SERIES 1230 & 1235**

# FLEX-TUBE® WELL-TYPE MANOMETERS

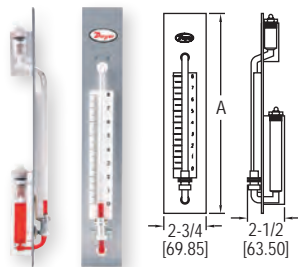

Series 1235 panel mounting

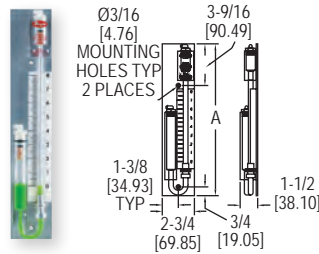

Series 1230 wall mounting

Model	Scale in Inches of Water or Mercury	Dimensions A		Mercury Required to Fill (Wt.)
		W/M	D	
1230-8	0-8	15-13/16	16-3/4	12 oz
1230-12	0-12	19-3/8	21-7/8	14 oz
1230-16	0-16	23-1/2	27	16 oz
1230-20	0-20	27-9/16	32-1/8	18 oz
1230-36	0-36	43-1/8	51-1/4	26 oz

Model	Scale in Inches of Water or Mercury	Dimensions A		Mercury Required to Fill (Wt.)
		W/M	D	
1235-20	0-20	29-5/16	33-9/16	18 oz

Dwyer® Series 1230 & 1235 Flex-Tube® Well Type Manometers are designed to meet the need for a direct reading single column instrument providing highly accurate pressure readings; positive, negative or differential. Unlike other makes, Dwyer manometers have no hidden wells or packing glands. These instruments are constructed of shatter-proof clear plastic tubing permanently bonded to well assemblies with leak-proof glued joints. Well assemblies are precisely machined from solid acrylic plastic. Over-pressure safety traps assure protection against loss of fluid. Scales are adjusted with quick-acting positive mechanism. These manometers are rated to 100 psig (6.89 bar). Not recommended for vacuum service beyond 5" Hg (68 in w.c.).

**FEATURES/BENEFITS**

- High-accuracy pressure measurement suitable for laboratory or general industry
- Precision built assures device meets the highest standards
- No moving parts mean no calibration or nothing to wear out
- Over-pressure trap prevents liquid from being expelled from gage, preventing disruption of operation

**APPLICATIONS**

- Laboratory and industrial service applications

**MODEL CHART**

Model
1230-8-W/M
1230-12-W/M
1230-16-W/M
1230-20-W/M
1230-36-W/M
1235-20-W/M

**Note:** Water/mercury models. For 0.826 S.P. gage fluid models change -W/M to a -D.

**OPTIONS**

To order add suffix:	Description
-NIST	NIST traceable calibration certificate
<b>Example:</b> 1222-8-W/M-NIST	

**ACCESSORIES - STANDARD**

**Description**

Include one set of type "a" connections, .826 sp. gr. red gage fluid for "D" style or fluorescein green dye concentrate with wetting agent for "W/M" styles, two 3 ft lengths of clear vinyl tubing and two 1/8" NPT tubing adapters.

# CAPSUHELIC® DIFFERENTIAL PRESSURE GAGE

Measures Pressure, Vacuum or Differential, Suitable for Internal Pressures to 500 psig



Capsuhelic® pressure gage has a large, easy-to-read 4" (102 mm) dial.

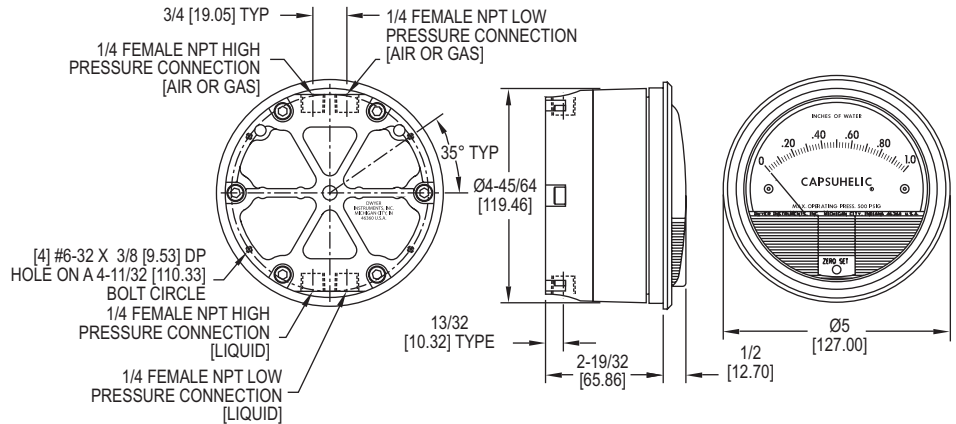

The **Series 4000 Capsuhelic® Differential Pressure Gage** is designed to give fast, accurate indication of differential pressures. The gage may be used as a readout device when measuring flowing fluids, pressure drop across filters, liquid levels in storage tanks and many other applications involving pressure, vacuum or differential pressure.

The pressure being measured is held within a capsule which is an integral part of the gage. This containment of the pressure permits the use of the gage on system pressures of up to 500 psig, even when differentials to be read are less than 0.1 in w.c.

#### FEATURES/BENEFITS

- Gage capsule permits high-pressure usage with small differentials
- Zero and range adjustments outside of gage means no disassembly in normal service
- Time-proven, simple, frictionless movement that permits full-scale readings as low as 0.5 in w.c.
- Diaphragm-actuated versus liquid filled gage supports outdoor use

#### APPLICATIONS

- Fluid flow
- Liquid storage tanks
- Filter pressure drops
- Vacuum or differential pressure

**Note:** May be used with hydrogen where pressures are less than 35 psi. Order with a Buna-N diaphragm.

MODEL CHART			
Model	Range	Model	Range
4005*	0-5.0 in w.c.	4310	5-0-5 in w.c.
4006*	0-6.0 in w.c.	4330	15-0-15 in w.c.
4010*	0-10 in w.c.	4205	0-5 psid
4015*	0-15 in w.c.	4210	0-10 psid
4020*	0-20 in w.c.	4215	0-15 psid
4025*	0-25 in w.c.	4220	0-20 psid
4030*	0-30 in w.c.	4616B**	0-16 ft w.c.
4040*	0-40 in w.c.	4635	0-35 ft w.c.
4050*	0-50 in w.c.		
4060*	0-60 in w.c.		
4080*	0-80 in w.c.		
4100*	0-100 in w.c.		
4200*	0-200 in w.c.		

\*These ranges available for vertical scale position only.  
\*\*Available only with the brass case for water service.  
**Note:** Scales reading directly in flow, heights, etc., are also available.

#### SPECIFICATIONS

**Service:** Aluminum case: Air and compatible gases and oil based liquids; Brass case: Air and compatible gases and water based liquids.  
**Wetted Materials:** Consult factory.  
**Housing:** Die cast aluminum with impregnated hard coating, standard. Optional forged brass housing is required for water or water based fluids. Special material diaphragms available, contact factory.  
**Accuracy:** ±3% of FS at 70°F (21.1°C). (±4% on 4200, 4210, 4215, 4220, 4300, 4400, and 4500).  
**Pressure Limits:** -20" Hg to 500 psig (-0.677 bar to 34.4 bar).  
**Temperature Limits:** 20 to 200°F (-6.67 to 93.3°C).  
**Size:** 4" (101.6 mm) diameter dial face.  
**Mounting Orientation:** Diaphragm in vertical position. Consult factory for other position orientations.  
**Process Connections:** 1/4" female NPT high and low pressure taps, duplicated - one pair top for air and gas, and one pair bottom for liquids.  
**Weight:** 3 lb, 3 oz (1.45 kg) aluminum case; 7 lb, 13 oz (3.54 kg) brass case.

#### OPTIONS

To order add suffix:	Description
-ASF	Adjustable signal flag
B	Brass case
Scale Overlays	Red, green, mirrored or combination; specify locations
-NIST	NIST traceable calibration certificate

#### ACCESSORIES - STANDARD

**Description**  
Two 1/4" NPT plugs for duplicate pressure taps, four flush mounting adapters with screws and four surface mounting screws.

#### ACCESSORIES

Model	Description
A-298	Flat flush mounting bracket
A-309	3-way manifold valve
A-314	Bleed fitting
A-370	Mounting bracket
A-471	Portable kit
A-496	Flush mount bracket
A-610	Pipe mount kit

USA: California Proposition 65  
⚠️WARNING: Cancer and Reproductive Harm - www.P65Warnings.ca.gov

Process Tubing Options: See page 455 (Gage Tubing Accessories)



SERIES PTGD

# DIFFERENTIAL PRESSURE PISTON-TYPE GAGES

Excellent Accuracy and Over-Pressure Ratings



Shown with optional pointer follower  
2.5"



4.5"

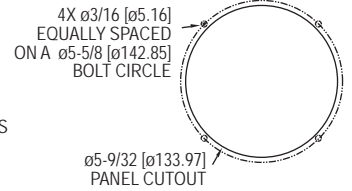
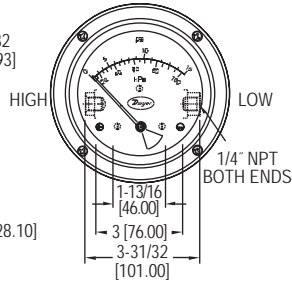
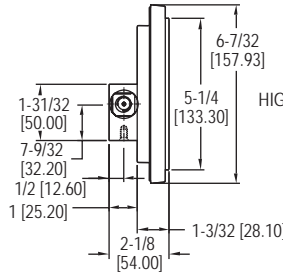
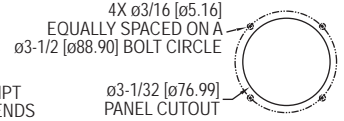
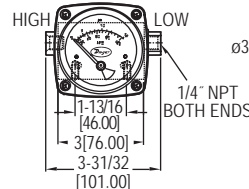
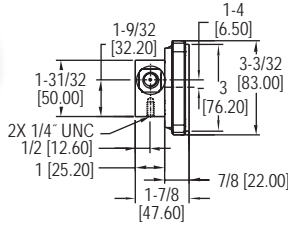

The Series PTGD Differential Pressure Piston-Type Gages can be used to measure the pressure drop across filters, strainers, pump performance testing, and heat exchanger pressure drop monitoring. Its simple, rugged design possesses weather and corrosion resistant gage front with a shatter resistant lens. The Series PTGD contains a piston-sensing element which provides different differential pressure ranges with full-scale accuracies of ±2%. Constructed with aluminum or 316 SS and available with two 1/4" female NPT end connections, the Series PTGD provides over-range protection rated to 3000 psig (200 bar) or 6000 psig (400 bar) depending on model. Standard models come with in-line connections. Back or bottom connections are also available.

**FEATURES/BENEFITS**

- Rugged, weather and corrosion proof design supports use in harsh environments
- Over-protection range depending on model, up to 6000 psig (400 bar) allows high-pressure applications
- Flexibility of connection selection fits the most sophisticated designs

**APPLICATIONS**

- Filter pressure drop
- Strainers
- Pump performance testing
- Heat exchanger pressure drop

**OPTIONS**

To order add suffix:	Description
-V	FKM fluoroelastomer seals
-N	EPDM seals
-PY	Glycerine fill
-PF	Pointer follower
-RP	Reverse port
-SP1	1 0.5A SPDT DIN plug
-SP2	2 0.25A SPDT DIN plugs
Use order code:	Description
NISTCAL-PG1	NIST traceable calibration certificate

**SPECIFICATIONS**

**Service:** Compatible gases and liquids.  
**Wetted Materials:** Gage body: Aluminum or 316 SS; Piston: Aluminum or 316 SS; Spring: 302 SS; Seals: Buna-N (standard); PTFE, Ceramic magnet; Dial case: Nylon 6 30% glass filled gage case.  
**Window:** Acrylic.  
**Accuracy:** ±2% FS.  
**Temperature Limit:** 176°F (80°C).  
**Pressure Limits:** 3000 psi (206 bar) for aluminum body; 6000 psi (413 bar) for SS body.  
**Size:** 2.5" (63 mm) or 4.5" (115 mm).  
**Mounting Orientation:** Mount in any position.  
**Process Connections:** 1/4" female NPT end connections standard; 1/4" female NPT back or bottom connections available. All styles available with 1/4" BSP.  
**Weight:** Aluminum: 2.5" 0.88 lb (399 g); 4.5" 1.35 lb (612 g); Stainless steel: 2.5" 1.75 lb (794 g); 4.5" 2.3 lb (1.04 kg).

**MODEL CHART**

Model	Description	Range
PTGD-AA01A	2.5" aluminum	0-5 psid (0.25 bar)
PTGD-AA02A	2.5" aluminum	0-10 psid (0.75 bar)
PTGD-AA03A	2.5" aluminum	0-15 psid (1 bar)
PTGD-AA04A	2.5" aluminum	0-20 psid (1.6 bar)
PTGD-AA05A	2.5" aluminum	0-25 psid (1.6 bar)
PTGD-AA06A	2.5" aluminum	0-30 psid (2 bar)
PTGD-AA07A	2.5" aluminum	0-40 psid (3 bar)
PTGD-AA08A	2.5" aluminum	0-50 psid (3.5 bar)
PTGD-AA09A	2.5" aluminum	0-60 psid (4 bar)
PTGD-AA10A	2.5" aluminum	0-80 psid (5.5 bar)
PTGD-AA11A	2.5" aluminum	0-100 psid (7 bar)
PTGD-AA12A	2.5" aluminum	0-150 psid (10 bar)
PTGD-SA01A	2.5" stainless steel	0-5 psid (0.25 bar)
PTGD-SA02A	2.5" stainless steel	0-10 psid (0.75 bar)
PTGD-SA03A	2.5" stainless steel	0-15 psid (1 bar)
PTGD-SA04A	2.5" stainless steel	0-20 psid (1.6 bar)
PTGD-SA05A	2.5" stainless steel	0-25 psid (1.6 bar)
PTGD-SA06A	2.5" stainless steel	0-30 psid (2 bar)
PTGD-SA07A	2.5" stainless steel	0-40 psid (3 bar)
PTGD-SA08A	2.5" stainless steel	0-50 psid (3.5 bar)
PTGD-SA09A	2.5" stainless steel	0-60 psid (4 bar)
PTGD-SA10A	2.5" stainless steel	0-80 psid (5.5 bar)
PTGD-SA11A	2.5" stainless steel	0-100 psid (7 bar)
PTGD-SA12A	2.5" stainless steel	0-150 psid (10 bar)

**Note:** For 4.5" dial face, change -AA to -AC for aluminum and -SA to -SC for stainless steel.  
 For back or bottom connections as well as female BSP threads, contact the factory.



# PROCESS FILTER GAGE

Indicates Process Filter Status, In-Line or Bottom Connect Mounting

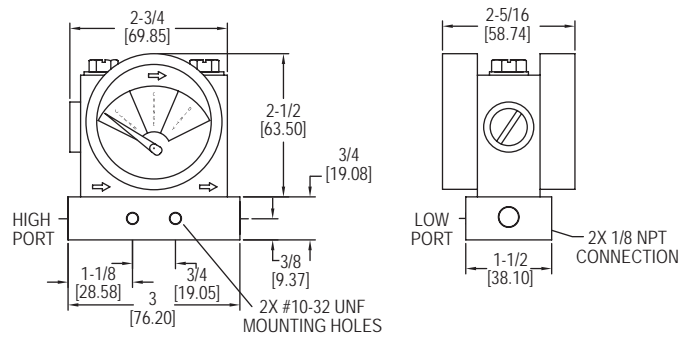

The **Series PFG2 Process Filter Gage** is designed for determining the state of an inline filter. The differential pressure indicator determines the pressure drop on either side of a filter and relates the value to one of three zones: clean (green), change (yellow), or dirty (red). The Series PFG2 is perfectly suited for filter applications, line loss, valve drop, and many other differential pressure applications where a simple indicator is needed. The direction of process flow is indicated on the dial, with the arrow pointing to the low pressure port. The PFG2 can be connected in-line through the side process connections, or can also be directly mounted through the outlet/inlet.

### FEATURES/BENEFITS

- Simple easy to understand indicator means no guessing filter status
- Removable mounting block provides direct mounting options especially in difficult filter access locations
- Quick installation reduces time to operation

### APPLICATIONS

- Filter pressure drop
- Filter status
- Valve drop
- Line loss

### SPECIFICATIONS

**Service:** Liquids/gases compatible with SS, GFN, and fluoropolymer.  
**Wetted Materials:** Aluminum, SS, glass filled nylon, and fluoropolymer.  
**Accuracy:** ±5% FS.  
**Temperature Limit:** 200°F (93°C).  
**Pressure Limit:** 300 psig (20.7 bar).  
**Materials:** Body: Glass filled nylon; Mounting Block: Aluminum; Lens: Polyester; Elastomers: Fluoroelastomer.  
**Process Connection:** 1/8" female NPT.  
**Mounting Orientation:** Any orientation with 10-32 threaded holes 3/4" apart.  
**Weight:** 9.6 oz (272.2 g).

### MODEL CHART

Model	Full Range	Green Zone	Yellow Zone	Red Zone
PFG2-02	0 to 5 psid	0 to 2.5 psid	2.5 to 3.75 psid	3.75 to 5 psid
PFG2-03	0 to 10 psid	0 to 5 psid	5 to 7.5 psid	7.5 to 10 psid
PFG2-06	0 to 25 psid	0 to 11 psid	11 to 18.5 psid	18.5 to 25 psid

## MODEL DIGIHELIC LINKS™

# DATA ACQUISITION AND LOGGING SOFTWARE

Designed for Communication with Series DH & DHII Digihelic® Differential Pressure Controllers



The **Model Digihelic Links™ Data Acquisition and Logging Software** is an easy to use Windows® based program. Data logging and graphing can be set up by the individual control with varying logging periods. Event logging, live instrument status, remote calibration as well as uploading pre-saved configuration files are some of the higher end capabilities the Digihelic Links™ Communications Software provides. The Digihelic Links™ Communications Software is compatible with all Series DH and DHII Digihelic® Differential Pressure Controllers.

### FEATURES/BENEFITS

- Log and graph data up to 10 units simultaneously; view up to 40 units
- Easy to use Windows® based operator interface
- Data logging at individually adjustable rates
- On-screen graphing of process values
- Upload and download saved control configuration profiles
- Remote calibration of controls

Model	Description
Digihelic Links™	Communications software CD

Model	Description
MN-1	Mini-Node™ USB/RS-485 converter

### REQUIRED EQUIPMENT COMPUTER REQUIREMENTS

The Digihelic Links™ Communications Software application will run on Windows® 95/98 and Windows® NT Workstation 4.0 (Service Pack 3 recommended), Windows® 2000 and Windows® XP software. The hardware requirements for each of these operating systems can be found in the documentation provided with that operating system. One available RS-485 port is needed to communicate with the control(s). A minimum of 4 MB of hard disk space is needed for the Digihelic Links™ Communications Software application files, and additional hard disk space is needed to store data log files. Log file size will vary depending on the duration and rate selected for the controls and the number of controls on line.

### COMMUNICATION REQUIREMENTS

To communicate with the Digihelic® Differential Pressure Controller from a PC with an RS-232 Serial Communications Port, an RS-485 to RS-232 converter is required to convert the signal from the Digihelic® controller RS-485 format to the RS-232 input of the PC. Recommended converters are the Models 351-9 RS-485 to RS-232 converter or Model MN-21 RS-485 to USB converter. For RS-485 systems a 120 Ω resistor is also needed to terminate the last control on the control network. Shielded twisted pair cable is recommended for wiring the controls together.

Windows® is a registered trademark of Microsoft Corporation

# DIGIHELIC® II DIFFERENTIAL PRESSURE CONTROLLER

## NEMA 4 (IP66) Housing With Large, Bright LCD, Square Root Output for Flow

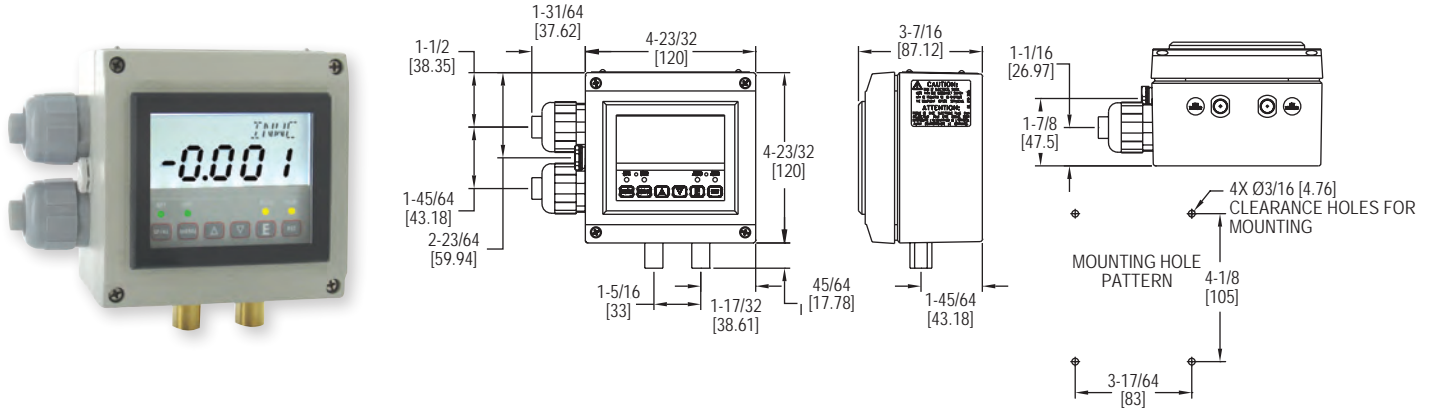

The **Series DHII Digihelic® II Differential Pressure Controller** takes all the features of the standard Digihelic® Pressure Controller and packages them in a robust NEMA 4 (IP66) housing.

The Digihelic® II Pressure Controller combines the 2 SPDT control relays, 4 to 20 mA process output and Modbus® communications with a large, brightly backlit 4 digit LCD display that can easily be seen from long distances. The electrical wiring has also been enhanced in the DHII with its detachable terminal blocks. The removable terminals allow the install to easily wire the terminal block outside the housing and then attach to the circuit board, reducing wiring difficulties and installation time on the process.

The Digihelic® II Differential Pressure Control in the NEMA 4 (IP66) enclosure enables this product to be the perfect choice when mounting pressure controls outdoors in such applications as rooftop air handlers. This housing also makes it the ideal solution for surface mounting in clean rooms or facilities where water or a cleaning solution is utilized in maintaining plant cleanliness.

### FEATURES/BENEFITS

- NEMA 4 housing enables a range of uses both outdoors or indoors where water is present
- Large backlight LCD display provides local reading from a distance
- Detachable terminal blocks reduce wiring difficulties saving installation time

### APPLICATIONS

- Air handlers
- Clean rooms

### ACCESSORIES

Model	Description
MN-1	Mini-Node™ USB/RS-485 converter
A-301	Static pressure tip for 1/4" metal tubing connection
A-302	Static pressure tip for 3/16" and 1/8" I.D. plastic or rubber tubing
A-438	Surface mounting brackets
A-489	4" straight static pressure tip with flange
A-302F-A	303 SS static pressure tip with mounting flange; for 3/16" ID rubber or plastic tubing; 4" insertion depth; includes mounting screws
Digihelic Links™	Communications software

### MODEL CHART - AVAILABLE PRESSURE ENGINEERING UNITS

Model	in w.c.	ft w.c.	mm w.c.	cm w.c.	psi	in Hg	mm Hg	mbar	Pa	kPa	hPa	oz/in <sup>2</sup>
DHII-002	.2500	-	6.350	0.635	-	-	0.467	0.623	62.28	-	0.623	0.144
DHII-004	1.000	-	25.40	2.540	-	-	1.868	2.491	249.1	0.249	2.491	0.578
DHII-006	5.000	.4167	127.0	12.70	.1806	.3678	9.342	12.45	1245	1.245	12.45	2.890
DHII-007	10.00	.8333	254.0	25.40	.3613	.7356	18.68	24.91	2491	2.491	24.91	5.780
DHII-008	25.00	2.083	635.0	63.50	.9032	1.839	46.71	62.27	6227	6.227	62.27	14.45
DHII-009*	50.00	4.167	1270	127.0	1.806	3.678	93.42	124.5	-	12.45	124.5	28.90
DHII-010*	100.0	8.333	2540	254.0	3.613	7.356	186.8	249.1	-	24.91	249.1	57.80

\*Velocity and volumetric flow not available on bi-directional range units and models DHII-009 & DHII-010.

### OPTIONS

Use order code:	Description
-NIST	NIST calibration certificate

### SPECIFICATIONS

- Service:** Air and non-combustible, compatible gases.
- Wetted Materials:** Consult factory.
- Housing Material:** Aluminum, glass.
- Accuracy:** ±0.5% at 77°F (25°C) including hysteresis and repeatability (after 1 hour warm-up).
- Stability:** < ±1% per year.
- Pressure Limits:** Ranges ≤ 2.5 in w.c. = 2 psi; 5": 5 psi; 10": 5 psi; 25": 5 psi; 50": 5 psi; 100": 9 psi.
- Temperature Limits:** 32 to 140°F (0 to 60°C).
- Compensated Temperature Limits:** 32 to 140°F (0 to 60°C).
- Thermal Effects:** 0.020%/°F (0.036/°C) from 77°F (25°C).
- Power Requirements:** High voltage power = 100 to 240 VAC, 50 to 400 Hz or 132 to 240 VDC; Low voltage power = 24 VDC ±20%.
- Power Consumption:** Low voltage power = 24 VDC - 130 mA max; High voltage power = 100 to 240 VAC, 132 to 240 VDC - 7 VA max.
- Output Signal:** 4 to 20 mA DC into 900 Ω max.
- Zero & Span Adjustments:** Accessible via menus.
- Response Time:** 250 ms (dampening set to 1).
- Display:** 4 digit backlit LCD 0.6" height. LED indicators for set point and alarm status.
- Electrical Connections:** Euro type removable terminal blocks with watertight conduit fittings for 1/2" watertight conduit.
- Process Connections:** 1/8" female NPT.
- Enclosure Rating:** Designed to meet NEMA 4 (IP66).
- Mounting Orientation:** Mount unit in horizontal plane.
- Weight:** 2 lb 10 oz (1.19 kg).
- Serial Communications:** Modbus® RTU, RS485, 9600 baud.
- Agency Approvals:** CE, UL.

### SWITCH SPECIFICATIONS

- Switch Type:** 2 SPDT relays.
- Electrical Rating:** 8 amps at 240 VAC resistive.
- Set Point Adjustment:** Adjustable via keypad on face.

### MODEL CHART - BI-DIRECTIONAL\* RANGES

Model	Range
DHII-012	0.25 to 0 to 0.25 in w.c.
DHII-014	1.0 to 0 to 1.0 in w.c.
DHII-015	2.5 to 0 to 2.5 in w.c.
DHII-016	5 to 0 to 5 in w.c.
DHII-017	10 to 0 to 10 in w.c.

\*Velocity and volumetric flow not available on bi-directional range units and models DHII-009 & DHII-010.

# DIGIHELIC® DIFFERENTIAL PRESSURE CONTROLLER

3-in-1 Instrument: Gage, Switch and Transmitter, Square Root Extractor for Air Flow

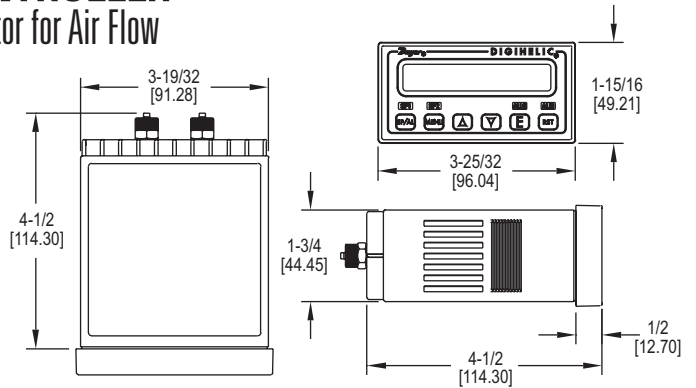

The Series DH DigiHelic® Differential Pressure Controller is a 3-in-1 instrument possessing a digital display gage, control relay switches, and a transmitter with current output. The DigiHelic® controller is the ideal instrument for pressure, velocity and flow applications, achieving a 0.5% full-scale accuracy on ranges from 0.25 to 100 in w.c. The DigiHelic® controller allows the selection of pressure, velocity or volumetric flow operation in several commonly used engineering units. Two SPDT control relays with adjustable dead bands are provided along with a scalable 4 to 20 mA process output. The Series DH provides extreme flexibility in power usage by allowing 120/220 VAC and also 24 VDC power which is often used in control panels. Programming is easy using the menu key to access 5 simplified menus which provide access to: security level; selection of pressure, velocity or flow operation; selection of engineering units; K-factor for use with flow sensors; rectangular or circular duct for inputting area in flow applications; set point control or set point and alarm operation; alarm operation as a high, low or high/low alarm; automatic or manual alarm reset; alarm delay; view peak and valley process readings; digital damping for smoothing erratic process applications; scaling the 4 to 20 mA process output to fit your application's range; Modbus® communications; and field calibration.

### FEATURES/BENEFITS

- 3-in-1 instrument allows the reduction of several instruments with one product, saving inventory, installation time and money
- Velocity of flow modes, a square root output coincides with the actual flow curve for greater precision
- Power usage of 120/220 VAC or 24 VDC provides flexibility to incorporate device in control panel
- Secure menu program provides access to device operation only for the right skill level
- Modbus® communications supports Process and HVAC system integration and control

### APPLICATIONS

- SCFM duct flow
- Industrial ovens air flow
- Filter status
- Clean room pressurization
- Fume hood air flow
- Surgical and medical room pressurization
- Damper and fan control

OPTIONS	
To order add suffix:	Description
-B	Barbed fitting for 3/16" ID tubing
-NIST	NIST traceable calibration certificate
Example: DH-004-NIST	
-FC	Factory calibration certificate
Example: DH-004-FC	

MODEL CHART - AVAILABLE PRESSURE ENGINEERING UNITS												
Model	in w.c.	ft w.c.	mm w.c.	cm w.c.	psi	in Hg	mm Hg	mbar	Pa	kPa	hPa	oz/in <sup>2</sup>
DH-002	.2500	-	6.350	0.635	-	-	0.467	0.623	62.28	-	0.623	0.144
DH-004	1.000	-	25.40	2.540	-	-	1.868	2.491	249.1	0.249	2.491	0.578
DH-006	5.000	.4167	127.0	12.70	.1806	.3678	9.342	12.45	1245	1.245	12.45	2.890
DH-007	10.00	.8333	254.0	25.40	.3613	.7356	18.68	24.91	2491	2.491	24.91	5.780
DH-008	25.00	2.083	635.0	63.50	.9032	1.839	46.71	62.27	6227	6.227	62.27	14.45
DH-009*	50.00	4.167	1270	127.0	1.806	3.678	93.42	124.5	-	12.45	124.5	28.90
DH-010*	100.0	8.333	2540	254.0	3.613	7.356	186.8	249.1	-	24.91	249.1	57.80

\*Velocity and volumetric flow not available on bi-directional range units and models DH-009 & DH-010.

### SPECIFICATIONS

**Service:** Air and non-combustible, compatible gases.  
**Wetted Materials:** Consult factory.  
**Housing Material:** ABS plastic, UL approved 94 V-0.  
**Accuracy:** ±0.5% at 77°F (25°C) including hysteresis and repeatability.  
**Stability:** < ±1% per year.  
**Pressure Limits:** Ranges ≤ 2.5 in w.c. = 2 psi; 5": 5 psi; 10": 5 psi; 25": 5 psi; 50": 5 psi; 100": 9 psi.  
**Temperature Limits:** 32 to 140°F (0 to 60°C).  
**Compensated Temperature Limits:** 32 to 140°F (0 to 60°C).  
**Thermal Effects:** 0.020%/°F (0.036/°C) from 77°F (25°C).  
**Power Requirements:** High voltage power = 100 to 240 VAC, 50 to 400 Hz or 132 to 240 VDC. Low voltage power = 24 VDC ±20%.  
**Power Consumption:** Low voltage power = 24 VDC - 130 mA max; High voltage power = 100 to 240 VAC, 132 to 240 VDC - 7VA max.  
**Output Signal:** 4 to 20 mA DC into 900 Ω max.  
**Zero & Span Adjustments:** Accessible via menus.  
**Response Time:** 250 ms.  
**Display:** 4 digit LCD 0.4" height. LED indicators for set point and alarm status.  
**Electrical Connections:** Screw terminals.  
**Process Connections:** Compression fitting for use with 1/8" ID x 1/4" OD tubing (3.175 mm ID x 6.35 mm OD). Optional barbed fitting for 3/16" ID tubing.  
**Enclosure Rating:** Face designed to meet NEMA 4X (IP66).  
**Mounting Orientation:** Mount unit in horizontal plane.  
**Size:** 1/8 DIN.  
**Panel Cutout:** 1.772 x 3.620 in (45 x 92 mm).  
**Weight:** 14.4 oz (408 g).  
**Serial Communications:** Modbus® RTU, RS485, 9600 baud.  
**Agency Approvals:** CE, UL.

### SWITCH SPECIFICATIONS

**Switch Type:** 2 SPDT relays.  
**Electrical Rating:** 8 amps at 240 VAC resistive.  
**Set Point Adjustment:** Adjustable via keypad on face.

### ACCESSORIES

Model	Description
MN-1	Mini-Node™ USB/RS-485 converter; the Mini-Node™ converters are an easy solution for utilizing the DigiHelic® controller's RS-485 serial communication and connecting to virtually any PC.
A-266	DigiHelic® surface mounting bracket
A-203	1/8" ID x 1/4" OD PVC tubing
DigiHelic Links™	Communications Software

MODEL CHART - BI-DIRECTIONAL* RANGES	
Model	Range
DH-012	0.25 to 0 to 0.25 in w.c.
DH-014	1.0 to 0 to 1.0 in w.c.
DH-015	2.5 to 0 to 2.5 in w.c.
DH-016	5 to 0 to 5 in w.c.
DH-017	10 to 0 to 10 in w.c.

\*Velocity and volumetric flow not available on bi-directional range units and models DH-009 & DH-010.

Modbus® is a registered trademark of Schneider Automation, Inc.  
 Process Tubing Options: See page 455 (Gage Tubing Accessories)



# DIGIHELIC® 3 DIFFERENTIAL PRESSURE CONTROLLERS

Digihelic® Controller in Photohelic® Gage, Square Root Output for Flow



**Note:** Shown with optional -SS bezel.  
Backward compatible\* with Magnehelic® gage.

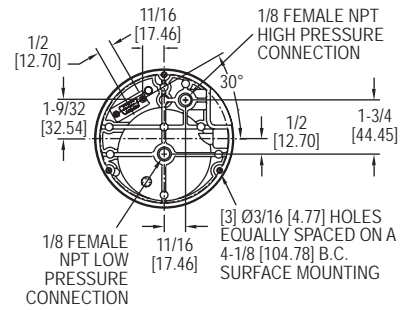
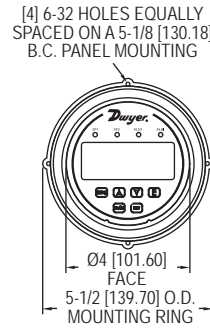
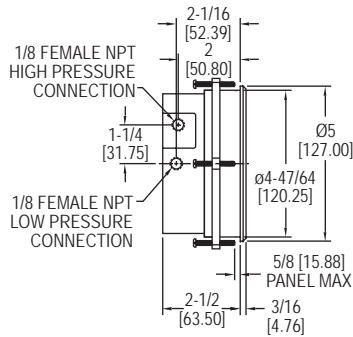

The **Series DH3 Digihelic® 3 Differential Pressure Controllers** are 3-in-1 instruments possessing a digital display gage, control relay switches, and a transmitter with current output all packed in the popular Photohelic® gage style housing. Combining these 3 features allows the reduction of several instruments with one product, saving inventory, installation time and money. The Digihelic® controller is the ideal instrument for pressure, velocity and flow applications, achieving a 1% full-scale accuracy on ranges down to the extremely low 0.25 in w.c. to 2.5 in w.c. full-scale. Ranges of 5 in w.c. and greater maintain 0.5% FS accuracy. Bi-directional ranges are also available. The Series DH3 Digihelic® controller allows the selection of pressure, velocity or volumetric flow operation in several commonly used engineering units. 2 SPDT control relays with adjustable deadbands are provided along with a scalable 4 to 20 mA process output.

Programming is easy using the menu key to access 5 simplified menus which provide access to: security level; selection of pressure, velocity or flow operation; selection of engineering units; K-factor for use with flow sensors; rectangular or circular duct for inputting area in flow applications; set point control or set point and alarm operation; alarm operation as a high, low or high/low alarm; automatic or manual alarm reset; alarm delay; view peak and valley process reading; digital damping for smoothing erratic process applications; scaling the 4 to 20 mA process output to fit your applications range and field calibration.

### FEATURES/BENEFITS

- 3-in-1 instrument allows the reduction of several instruments with one product, saving inventory, installation time and money
- Full-scale accuracy of 1% even on extremely low ranges, and 0.5% for ranges above 5 in w.c. provide for greater measurement precision
- Secure menu program provides access to device operation only for the right skill level
- Optional stainless steel bezel is the same installation diameter as Magnehelic® gage and simplifies field upgrade to DH3 pressure controller

### APPLICATIONS

- SCFM duct flow
- Filter status
- Duct or building static pressure
- Damper and fan control

### MODEL CHART

Model	Ranges	Model	Ranges
DH3-002	0 to 0.25 in w.c.	*DH3-010	0 to 50 in w.c.
DH3-003	0 to 0.5 in w.c.	*DH3-011	0 to 100 in w.c.
DH3-004	0 to 1 in w.c.	*DH3-013	0 to ±0.25 in w.c.
DH3-005	0 to 2.5 in w.c.	*DH3-014	0 to ±0.5 in w.c.
DH3-006	0 to 5 in w.c.	*DH3-015	0 to ±1 in w.c.
DH3-007	0 to 10 in w.c.	*DH3-016	0 to ±2.5 in w.c.
DH3-009	0 to 25 in w.c.	*DH3-017	0 to ±5 in w.c.
		*DH3-018	0 to ±10 in w.c.

\*Velocity and volumetric flow not available on bi-directional range units and models DH3-010 and DH3-011.

### SPECIFICATIONS

**Service:** Air and non-combustible, compatible gases.  
**Wetted Materials:** Consult factory.  
**Housing Material:** Die cast aluminum case and bezel.  
**Accuracy:** ±1.5% for 0.25 in and ±0.25 in w.c. ranges. Ranges 0.5 in to 5 in w.c. and corresponding bi-directional (except ±2.5 in w.c.) ±1%; All other ranges: ±0.5% @ 77°F (25°C) including hysteresis and repeatability (after 1 hour warm-up).  
**Stability:** < ±1% per year.  
**Pressure Limits:** Ranges ≤ 2.5 in w.c.: 25 psi; ±2.5": 5 in w.c.: 5 psi; 10 in w.c.: 5 psi; 25 in w.c.: 5 psi; 50 in w.c.: 5 psi; 100 in w.c.: 9 psi.  
**Temperature Limits:** 32 to 140°F (0 to 60°C).  
**Compensated Temperature Limits:** 32 to 140°F (0 to 60°C).  
**Thermal Effects:** 0.020%/°F (0.036/°C) from 77°F (25°C). For 0.25 in and ±0.25 in w.c. ranges: ±0.03%/°F (±0.054/°C).  
**Power Requirements:** 12-28 VDC, 12-28 VAC 50 to 400 Hz.  
**Power Consumption:** 3 VA max.

**Output Signal:** 4 to 20 mA DC into 900 Ω max.  
**Zero & Span Adjustments:** Accessible via menus.  
**Response Time:** 250 ms (damping set to 1).  
**Display:** Backlit 4 digit LCD 0.4" height LED indicators for set point and alarm status.  
**Electrical Connections:** 15 pin male high density D-sub connection. 18" (46 cm) cable with 10 conductors included.  
**Process Connections:** 1/8" female NPT. Side or back connections.  
**Mounting Orientation:** Mount unit in vertical plane.  
**Size:** 5" (127 mm) OD x 3-1/8" (79.38 mm); -SS bezel: 4-3/4" (120.7 mm) OD x 2-21/32 (67.5 mm).  
**Weight:** 1.75 lb (794 g).  
**Agency Approvals:** CE.

### SWITCH SPECIFICATIONS

**Switch Type:** 2 SPDT relays.  
**Electrical Rating:** 1 A @ 30 VAC/VDC.  
**Set Point Adjustment:** Adjustable via keypad on face.

### ACCESSORIES

Model	Description
A-298	Flat aluminum bracket for flush mounting
A-301	Static pressure tip for 1/4" metal tubing connection
A-302	Static pressure tip for 3/16" and 1/8" I.D. plastic or rubber tubing
A-302F-A	303 SS static pressure tip with mounting flange; for 3/16" ID rubber or plastic tubing; 4" insertion depth; includes mounting screws
A-370	Mounting bracket flush mount bracket; bracket is then surface mounted; steel with gray hammertone epoxy finish
A-489	4" straight static pressure tip with flange

### OPTIONS

To order add suffix:	Description
-SS	304 brushed stainless steel bezel. *Backward compatible with standard Magnehelic® gage installation diameter
<b>Example:</b> DH3-004-SS	
-NIST	NIST traceable calibration certificate
<b>Example:</b> DH3-004-NIST	
-FC	Factory calibration certificate
<b>Example:</b> DH3-004-FC	

Process Tubing Options: See page 455 (Gage Tubing Accessories)



# ATEX/IECEx APPROVED DH3 DIFFERENTIAL PRESSURE CONTROLLER

Digihelic® Pressure Control in Flame-Proof ATEX/IECEx Enclosure

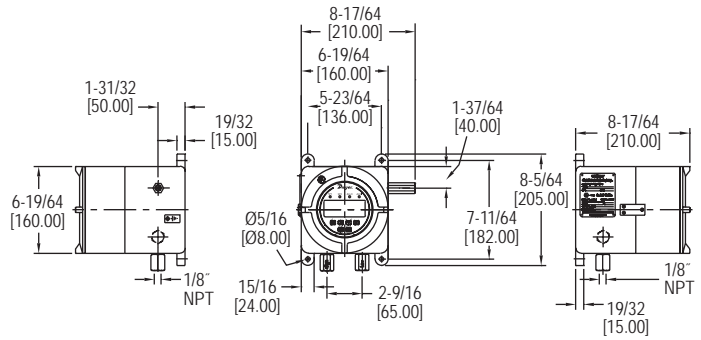

The **Series AT2DH3 ATEX/IECEx Approved DH3 Differential Pressure Controller** is a 3-in-1 instrument possessing a digital display gage, control relay switches, and a transmitter with current output. Combining these three features allows the reduction of several instruments with one product, saving inventory, installation time and money. The Digihelic® controller is the ideal instrument for hazardous area pressure, velocity and flow applications by allowing for the selection of pressure, velocity or volumetric flow operation in several commonly used engineering units. Two SPDT control relays with adjustable dead bands are provided along with a scalable 4-20 mA process output. In velocity or flow modes, a square root output is provided on the 4-20 mA signal to coincide with the actual flow curve. Flame-proof enclosures are available in aluminum and can include a glass window for viewing process information and set point status on digital display.

**FEATURES/BENEFITS**

- 3-in-1 instrument allows the reduction of several instruments with one product, saving inventory, installation time and money
- Flame-proof enclosure with optional glass window and aluminum housing protects the device in hazardous areas while giving local visibility to process pressure and set point status

**APPLICATIONS**

- Hazardous area pressure measurement and switching

**Attention:** Check local safety rules and warnings on unit and manual for a correct use of the instrument in hazardous area.

**SPECIFICATIONS**

**Service:** Air and non-combustible, compatible gases.  
**Wetted Materials:** Consult factory.  
**DH3 Housing Material:** Die cast aluminum case and bezel.  
**Housing Material:** Aluminum.  
**Finishing:** Texture epoxy coat RAL7038.  
**Accuracy:** < 5 in w.c. (except ±2.5 in w.c.): ±1%; All other ranges: ±0.5% at 77°F (25°C) including hysteresis and repeatability (after 1 hour warm-up).  
**Stability:** < ±1% per year.  
**Pressure Limits:** Ranges ≤ 2.5 in w.c.: 25 psi; ±2.5", 5 in w.c.: 5 psi; 10 in w.c.: 5 psi; 25 in w.c.: 5 psi; 50 in w.c.: 5 psi; 100 in w.c.: 9 psi.  
**Temperature Limits:** 32 to 140°F (0 to 60°C) (**Note:** Product temperature limits differ from case).  
**Compensated Temperature Limits:** 32 to 140°F (0 to 60°C).  
**Thermal Effects:** 0.020%/°F (0.036/°C) from 77°F (25°C).  
**Power Requirements:** 12-28 VDC, 12-28 VAC 50 to 400 Hz.  
**Power Consumption:** 3 VA max.  
**Output Signal:** 4-20 mA DC into 900 Ω max.  
**Zero & Span Adjustments:** Accessible via menus in safe zone only.  
**Response Time:** 250 ms (damping set to 1).  
**Display:** Backlit 4 digit LCD 0.4" height LED indicators for set point and alarm status.  
**Process Connections:** 1/8" NPT female brass (SS optional). In presence of acetylene it is necessary to use SS.  
**Electrical Connections:** Two 1/2" NPT female. Cable gland not included.  
**Weight:** 12.3 lb (5.6 kg).  
**Electrical Wiring:** Screw terminal.  
**Mounting Orientation:** Mount unit in vertical plane.  
**Enclosure Rating:** (IP66). IP65 with option OPV, overpressure relief valve.  
**Dial Size:** 5" (127 mm) OD x 3-1/8" (79.38 mm).  
**ATEX Certificate:** BVI 14ATEX0072.  
**Agency Approvals:** ATEX Compliant **CE** 1370 **Ex** II 2G Ex d IIC T6 Gb / II 2D Ex tb IIIC T85°C Db, -60°C ≤ Tamb ≤ +60°C IECEx Compliant: Ex d IIC T6 Gb / Ex tb IIIC T85°C Db.  
**SWITCH SPECIFICATIONS**  
**Switch Type:** 2 SPDT relays.  
**Electrical Rating:** 1 A @ 30 VAC/VDC.  
**Set Point Adjustment:** Adjustable via keypad on face in safe zone only.

MODEL CHART								
Example	AT2DH3	-002	-A	O	1	X	T2	AT2DH3-002-AO1XT2
Series	AT2DH3							ATEX/IECEx approved DH3 differential pressure controller
Range		002 003 004 005 006 007 009 010 011 013 014 015 016 017 018						0 to 0.25 in w.c. (0 to 62.2 Pa) 0 to 0.5 in w.c. (0 to 124.4 Pa) 0 to 1 in w.c. (0 to 248.8 Pa) 0 to 2.5 in w.c. (0 to 622.1 Pa) 0 to 5 in w.c. (0 to 1244.2 Pa) 0 to 10 in w.c. (0 to 2488.4 Pa) 0 to 25 in w.c. (0 to 6221 Pa) 0 to 50 in w.c. (0 to 12442 Pa) 0 to 100 in w.c. (0 to 24884 Pa) 0.25 to 0 to 0.25 in w.c. (62.2 to 0 to 62.2 Pa) 0.5 to 0 to 0.5 in w.c. (124.4 to 0 to 124.4 Pa) 1 to 0 to 1 in w.c. (248.8 to 0 to 248.8 Pa) 2.5 to 0 to 2.5 in w.c. (622.1 to 0 to 622.1 Pa) 5 to 0 to 5 in w.c. (1244.2 to 0 to 1244.2 Pa) 10 to 0 to 10 in w.c. (2488.4 to 0 to 2488.4 Pa)
Housing Material			A					Aluminum
Cover				B O				Blind Glass top cover
Process Connection					1 2			1/8" NPT F brass ports 1/8" NPT F SS ports
Overpressure Plug						X OPV		Standard without overpressure relief valve Overpressure relief valve Material same as port
Tag							T2	SS information label

USA: California Proposition 65  
 ⚠WARNING: Cancer and Reproductive Harm  
 www.P65Warnings.ca.gov

# PHOTOHELIC® PRESSURE SWITCH/GAGE

## 3-in-1 Indicating Gage, Lo-Limit and Hi-Limit Control



Set points are instantly adjusted with front knobs

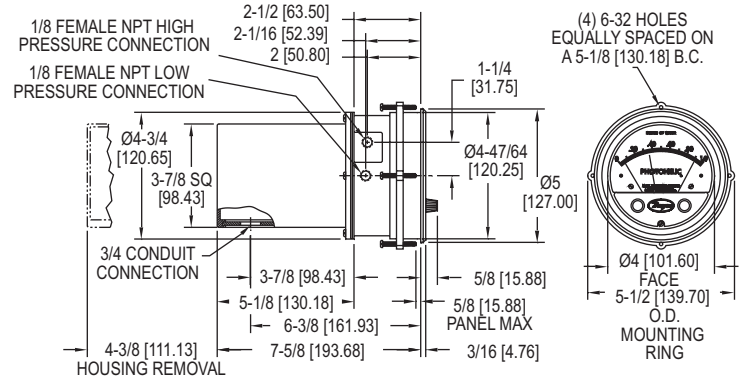

The **Series A3000 Photohelic® Pressure Switch/Gage** functions as versatile, highly repeatable pressure switches combined with a precise pressure gage employing the time-proven Magnehelic® gage design. The Photohelic® switch/gage measures and controls positive, negative or differential pressures of air and compatible gases. Standard models are rated to 25 psig (1.7 bar) with options to 35 (2.4) or 80 (5.5 bar) psig. Two phototransistor actuated, DPDT relays are included for low/high limit control. Easy to adjust set point indicators are controlled by knobs located on the gage face. Individual set point deadband is one pointer width - less than 1% of full-scale. Set points can be interlocked to provide variable deadband - ideal for control of fans, dampers, etc. Gage reading is continuous and unaffected by switch operation, even during loss of electrical power. Choose from full-scale pressure ranges from a low 0-.25 in (0-6 mm) w.c. up to 30 psi (21 bar).

### FEATURES/BENEFITS

- 3-in-1 instrument allows the reduction of several instruments with one product, saving inventory, installation time and money
- Patented design and 1% full-scale dead band provides quick response to pressure changes means no delay in switching and chatter-free operation
- A wide range of models that can meet pressure measurement specifications from low to very high

### APPLICATIONS

- Air conditioning systems
- Clean rooms
- Fume exhaust systems

### SPECIFICATIONS

#### GAGE SPECIFICATIONS

**Service:** Air and non-combustible, compatible gases.

**Wetted Materials:** Consult factory.

**Accuracy:** ±2% of FS at 70°F (21.1°C). ±3% on -0 and ±4% on -00 models.

**Pressure Limits:** -20" Hg to 25 psig (-0.677 to 1.72 bar); MP option: 35 psig (2.41 bar); HP option: 80 psig (5.52 bar).

**Temperature Limits:** 20 to 120°F (-6.67 to 48.9°C). Low temperature option available.

**Process Connections:** 1/8" female NPT.

**Size:** 4" (101.6 mm) dial face, 5" (127 mm) OD x 8-1/4" (209.55 mm).

**Weight:** 4 lb (1.81 kg).

#### SWITCH SPECIFICATIONS

**Switch Type:** Each set point has 2 form C relays (DPDT).

**Repeatability:** ±1% of FS.

**Electrical Rating:** 10 A @ 28 VDC, 10 A @ 120, 240 VAC.

**Electrical Connections:** Screw terminals. Use 167°F (75°C) copper conductors only.

**Power Requirements:** 120 VAC, 50/60 Hz; 240 VAC and 24 VAC power optional.

**Mounting Orientation:** Diaphragm in vertical position. Consult factory for other position orientations.

**Set Point Adjustment:** Adjustable knobs on face.

**Agency Approvals:** CE, CSA, UL.

# PHOTOHELIC® PRESSURE SWITCH/GAGE

## 3-in-1 Indicating Gage, Lo-Limit and Hi-Limit Control

**Bezel and front cover** (with set point knobs and zero adjustment screw) removed to expose Photohelic® gage set point mechanism. Cover is clear polycarbonate plastic.

**Gage pointer and light shutter** are mounted on helix and balancing counterweight. Shutter passes through slot in optical limit switch to expose phototransistors to integral infrared light source or mask them depending on applied pressure.

**Light shield** effectively protects phototransistors from strong outside light sources yet allows free pointer movement. It also gives interior a clean "finished" look.

**Optical limit switches** are used for reliability and long service life. Attached directly to set pointers, they are individually aligned to assure precise switching accuracy.

**Semi-Flexible drive shaft** connects to set point knobs.

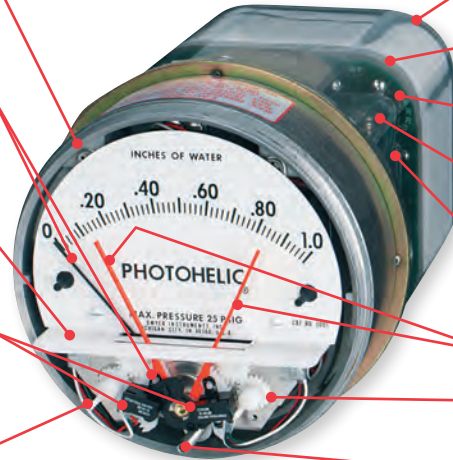

**Plastic enclosure** protects electronic components and electrical connections.

**Polycarbonate connection** or terminal board is self-extinguishing.

**Glass-epoxy printed circuit boards** for durability and performance.

**Load relays** are DPDT with latching feature for maximum application versatility.

**Electronics** are designed to operate on 50/60 Hz, 120 volt current with 10% over or under voltage. Special units for other voltages are available.

**Switch set pointers** show switch settings at all times.

**Spring loaded friction clutch** prevents operator damage of set point mechanism.

**Zero adjustment screw** connects to screw in cover to adjust zero pressure reading.

### MODEL CHART

Model	Range, in w.c.	Zero Center Ranges		Model	Range, mm w.c.	Zero Center Ranges	
		Model	Range in w.c.			Model	Range, Pa
A3000-00	0-.25	A3300-0	.25-0-.25	A3000-6MM	0-6	A3300-250PA	125-0-125
A3000-0	0-.50	A3301	.5-0-.5	A3000-10MM	0-10	A3300-500PA	250-0-250
A3001	0-1.0	A3302	1-0-1	A3000-25MM	0-25	Model	Range, kPa
A3002	0-2.0	A3304	2-0-2	A3000-50MM	0-50		
A3003	0-3.0	A3310	5-0-5	A3000-80MM	0-80	A3000-1KPA	0-1
A3004	0-4.0	A3320	10-0-10	A3000-100MM	0-100	A3000-1.5KPA	0-1.5
A3005	0-5.0	A3330	15-0-15	Zero Center		A3000-2KPA	0-2
A3006	0-6.0	Model	Range in w.c. /Air Velocity, F.P.M.	A3300-20MM	10-0-10	A3000-3KPA	0-3
A3008	0-8.0			A3300-30MM	15-0-15	A3000-4KPA	0-4
A3010	0-10	A3000-00AV	0-.25/300-2000	Model	Range, Pascals	A3000-5KPA	0-5
A3015	0-15					A3000-0AV	0-.50/500-2800
A3020	0-20	A3001AV	0-1.0/500-4000	A3000-60PA	0-60	A3000-10KPA	0-10
A3025	0-25	A3002AV	0-2.0/1000-5600	A3000-125PA	0-125	A3000-15KPA	0-15
A3030	0-30	A3010AV	0-10/2000-12500	A3000-250PA	0-250	A3000-20KPA	0-20
A3040	0-40	Pitot tube required		A3000-500PA	0-500	A3000-25KPA	0-25
A3050	0-50			A3000-750PA	0-750	A3000-30KPA	0-30
A3060	0-60			Zero Center Ranges			
A3080	0-80					Model	Range, kPa
A3100	0-100					A3300-1KPA	.5-0-.5
A3150	0-150					A3300-3KPA	1.5-0-1.5
Bi-Directional Range							
A3000-00N	.05-.20						

### OPTIONS

To order add suffix:	Description
-SRH	Single relay activates on increase
-SRL	Single relay activates on decrease
-OLS	OEM model
-RMR	Remote mounted relay
-TAMP	Tamper proof knobs
-MP	Medium pressure
-HP	High pressure
-LT	Low temperature (-20°F)
-NIST	NIST traceable calibration certificate

### ACCESSORIES

Model	Description
A-298	Flat flush mounting bracket
A-601	Manual reset switch net

**Note:** Special models can be built to OEM customers' specifications with scales reading in special pressure units like ounces per square inch, inches of mercury, etc. Square Root Scales reading in FPM or SCFM are also available. Custom logos and special graduations can also be included. Contact factory for minimum quantities and pricing.

Process Tubing Options: See page 455 (Gage Tubing Accessories)

# ATEX/IECEX APPROVED PHOTOHELIC® SWITCH/GAGE

## WITH 120, 240 OR 24 VAC POWER

Photohelic® Switch/Gages in Flame-Proof ATEX/IECEX Enclosures

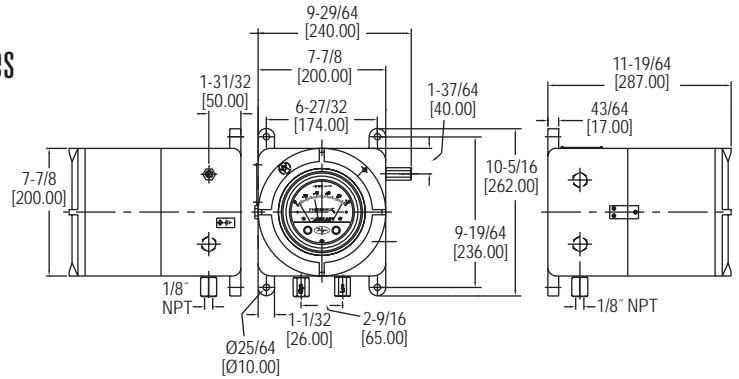

Flame-proof approved **Series AT3A3000 ATEX/IECEX Approved Photohelic® Switch/Gage with 120, 240 or 24 VAC Power** functions as versatile, highly repeatable pressure switches combined with a precise pressure gage employing the time-proven Magnehelic® gage design. The Photohelic® switch/gage measures and controls positive, negative or differential pressures of air and compatible gases. Standard models are rated to 25 psig (1.7 bar) with options to 35 psig (2.4 bar) or 80 psig (5.5 bar). Two phototransistor actuated, DPDT relays are included for low/high limit control. Easy to adjust set point indicators are controlled by knobs located on the gage face (accessible opening case after de-energizing instrument). Set points can be interlocked to provide variable dead band—ideal for control of fans, dampers, etc. Gage reading is continuous and unaffected by switch operation, even during loss of electrical power. Flame-proof enclosures are available in aluminum with glass window which allows for viewing of set point needles and process pressure.

**FEATURES/BENEFITS**

- 3-in-1 ATEX/IECEX approved instrument allows the reduction of several instruments with one product, saving inventory, installation time and money
- Flame-proof enclosure with optional glass window and aluminum housing protects the device in hazardous areas while giving local visibility to process pressure and set point status

**APPLICATIONS**

- Hazardous area pressure measurement and switching
- Air conditioning systems
- Clean rooms
- Fume exhaust systems

**Attention:** Check local safety rules and warnings on unit and manual for a correct use of the instrument in hazardous area.

**SPECIFICATIONS**

**Service:** Air and non-combustible, compatible gases.  
**Wetted Materials:** Consult factory.  
**Housing material:** Aluminum.  
**Finishing:** Texture epoxy coat RAL7038.  
**Accuracy:** ±2% of FS at 70°F (21.1°C); ±3% on -0 and ±4% on -00 models.  
**Pressure Limits:** -20 in Hg to 25 psig (-0.677 to 1.72 bar). MP option; 35 psig (2.41 bar), HP option; 80 psig (5.52 bar).  
**Temperature Limits:** 20 to 120°F (-6.67 to 48.9°C) LT low temperature option to -20°F available (**Note:** Product temperature limits differ from case).  
**Dial Size:** 4" (101.6 mm).  
**Mounting Orientation:** Diaphragm in vertical position.  
**Set Point Adjustment:** Adjustable knobs on Photohelic® gage face behind enclosure cover. Follow instructions and safety warnings to open cover.

**SWITCH SPECIFICATIONS**

**Switch Type:** Each set point has 2 Form C relays (DPDT).  
**Repeatability:** ±1% of FS.  
**Electrical Rating:** 10 A @ 28 VDC, 10 A @ 120, 240 VAC.  
**Electrical Wiring:** Screw terminals.  
**Power Requirements:** 120 VAC, 50/60 Hz; 240 VAC & 24 VAC power optional.  
**Enclosure Rating:** IP66. IP65 with option OPV, overpressure relief valve.  
**Process Connections:** 1/8" NPT female brass (SS optional). In presence of acetylene it is necessary to use SS.  
**Electrical Connections:** Three 1/2" NPT female. Cable gland not included.  
**Weight:** 28.4 lb (12.9 kg).  
**ATEX Certificate:** BVI 14ATEX0072.  
**Agency Approvals:** ATEX Compliant **CE** 1370 **Ex** II 2G Ex d IIC T6 Gb / II 2D Ex tb IIIC T85°C Db, -60°C ≤ Tamb ≤ +60°C IECEx Compliant: Ex d IIC T6 Gb / Ex tb IIIC T85°C Db.

RANGE CHART					
Model	Range in w.c.	Model	Range in w.c.	Model	Range in w.c.
A3000-00	0 to .25	A3006	0 to 6.0	A3040	0 to 40
A3000-0	0 to .50	A3008	0 to 8.0	A3050	0 to 50
A3001	0 to 1.0	A3010	0 to 10	A3060	0 to 60
A3002	0 to 2.0	A3015	0 to 15	A3080	0 to 80
A3003	0 to 3.0	A3020	0 to 20	A3100	0 to 100
A3004	0 to 4.0	A3025	0 to 25	A3150	0 to 150
A3005	0 to 5.0	A3030	0 to 30		

MODEL CHART												
Example	AT3	A3001	-120VAC	-X	X	X	-A	B	1	X	T2	AT3A3001-120VAC-XXX-AB1XT2
Housing	AT3											ATEX/IECEX approved Photohelic® switch/gages
Range		A3XXX										Specify range by wiring Photohelic® model number. See range chart.
Power			120VAC 240VAC 24VAC									Power requirement 120 VAC Power requirement 240 VAC Power requirement 24 VAC
Pressure Rating				X								Standard -25 in Hg to 25 psig Medium pressure max. static 35 psig High pressure max. static 80 psig
Construction					X							Standard silicone construction
Temperature Rating						X						Standard temperature 20 to 120°F Low temperature to -20°F
Housing Material							A					Aluminum
Cover								B	O			Blind Glass cover
Process Connection									1	2		1/8" NPT female brass ports 1/8" NPT female SS ports
Overpressure Plug										X	OPV	Standard without overpressure relief valve Overpressure relief valve Material same as ports
Tag											T2	SS information label

USA: California Proposition 65  
 ⚠WARNING: Cancer and Reproductive Harm - www.P65Warnings.ca.gov





# PHOTOHELIC® SWITCH/GAGES

Combines Differential Pressure Gage with Low/High Set-Points, Compact Size



**Note:** Shown with optional -SS bezel.  
Backward compatible\* with Magnehelic® gage.

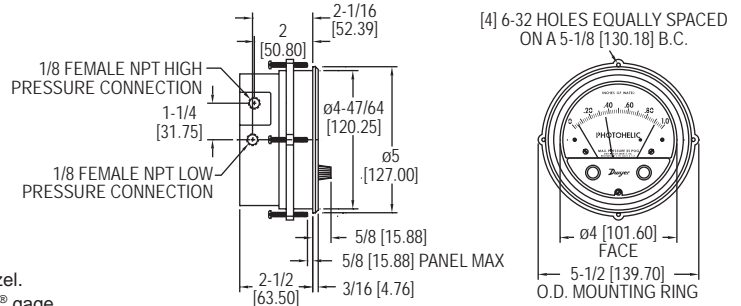

Using solid state technology, the **Series 3000MR & 3000MRS Photohelic® Switch/Gages** combine the functions of a precise, highly repeatable differential pressure switch with a large easy-to-read analog pressure gage employing the durable, time-proven Magnehelic® gage design. Switch setting is easy to adjust with large external knobs on the gage face. Gage reading is unaffected by switch operation - will indicate accurately even if power is interrupted. Solid state design now results in greatly reduced size and weight. Units can be flush mounted or surface mounted with hardware supplied. 3000MR models employ versatile electromechanical relays with gold over silver contacts - ideal for dry circuits. For applications requiring high cycle rates, choose 3000MRS models with SPST (N.O.) solid state relays. All models provide both low and high limit control and include 18-inch (45 cm) cable assemblies for electrical connections. Compatible with air and other non-combustible, non-corrosive gases, they can be used in systems with pressures to 25 psig (1.725 bar). Optional construction is available for use to either 35 psig (2.42 bar) or 80 psig (5.51 bar).

**FEATURES/BENEFITS**

- Gage reading unaffected by switch operation and will continue to read pressure even during power loss
- Zero and range adjustments outside of gage means no disassembly in normal service
- Solid-state design allows for switching in high cycle rate applications without degradation
- Optional stainless steel bezel is the same installation diameter as Magnehelic® gage and simplifies field upgrade to Photohelic® switch/gage

**APPLICATIONS**

- Pneumatic conveying
- Air conditioning systems
- Clean rooms

**MODEL CHART**

Model	Range, in w.c.	Minor Divs.	Model	Range, in w.c.	Minor Divs.
3000MR-00	0-0.25	.005	3000MRS-00**	0-0.25	.005
3000MR-0	0-0.5	.01	3000MRS-0*	0-0.5	.01
3001MR	0-1.0	.02	3001MRS	0-1.0	.02
3002MR	0-2.0	.05	3002MRS	0-2.0	.05
3003MR	0-3.0	.10	3003MRS	0-3.0	.10
3005MR	0-5.0	.10	3005MRS	0-5.0	.10
3010MR	0-10	.20	3010MRS	0-10	.20
3015MR	0-15	.50	3015MRS	0-15	.50
3020MR	0-20	.50	3020MRS	0-20	.50
3030MR	0-30	1.0	3030MRS	0-30	1.0
3050MR	0-50	1.0	3050MRS	0-50	1.0
3100MR	0-100	2.0	3100MRS	0-100	2.0

Model	Range, Pascals	Minor Divs.	Model	Range, Pascals	Minor Divs.
3000MR-60PA**	0-60	2.0	3000MRS-60PA**	0-60	2.0
3000MR-125PA*	0-125	5.0	3000MRS-125PA*	0-125	5.0
3000MR-250PA	0-250	5.0	3000MRS-250PA	0-250	5.0
3000MR-500PA	0-500	10.0	3000MRS-500PA	0-500	10.0

Model	Range, kPa	Minor Divs.	Model	Range, kPa	Minor Divs.
3000MR-1KPA	0-1.0	.02	3000MRS-1KPA	0-1.0	.02
3000MR-3KPA	0-3.0	.10	3000MRS-3KPA	0-3.0	.10
3000MR-4KPA	0-4.0	.10	3000MRS-4KPA	0-4.0	.10

Model	Range, mm w.c.	Minor Divs.	Model	Range, mm w.c.	Minor Divs.
3000MR-6MM**	0-6	.20	3000MRS-6MM**	0-6	.20
3000MR-10MM*	0-10	.50	3000MRS-10MM*	0-10	.50
3000MR-25MM	0-25	.50	3000MRS-25MM	0-25	.50
3000MR-50MM	0-50	1.0	3000MRS-50MM	0-50	1.0
3000MR-100MM	0-100	2.0	3000MRS-100MM	0-100	2.0

Model	Range, cm w.c.	Minor Divs.	Model	Range, cm w.c.	Minor Divs.
3000MR-20CM	0-20	.50	3000MRS-20CM	0-20	.50

\*±3% of full-scale. \*\*±4% of full-scale.  
**Note:** To order, select either MR or MRS suffix to Series 3000 number.  
**Examples:** 3001MR or 3001MRS

**SPECIFICATIONS**

**GAGE SPECIFICATIONS**  
**Service:** Air and non-combustible, compatible gases.  
**Wetted Materials:** Consult factory.  
**Accuracy:** ±2% of FS (3000-0 ±3% of FS). (3000-00 ±4% of FS).  
**Pressure Limit:** -20" Hg. to 25 psig (-0.677 bar to 1.72 bar). MP option: 35 psig (2.41 bar), HP option: 80 psig (5.52 bar).  
**Temperature Limits:** 20 to 120°F (-6.67 to 48.9°C).  
**Process Connections:** 1/8" female NPT (duplicated side and back).  
**Size:** 4" (101.6 mm) dial face, 5" (127 mm) OD x 3-1/8" (79.38 mm); -SS bezel: 4-3/4" (120.7 mm) OD x 2-21/32 (67.5 mm).  
**Weight:** 1.8 lb (816 g).

**SWITCH SPECIFICATIONS 3000MR**  
**Switch Type:** Each set point has 1 form C relays (SPDT).  
**Relay Contacts:** (Resistive load) 1 form C rated 1.0A @ 30 VDC, 0.3A @ 110 VDC or 0.5A @ 125 VAC. Gold over clad silver - suitable for dry circuits.

**Electrical Connections:** 18" (46 cm) cable assembly with 8 conductors. Optional lengths to 100' (30.5 m).  
**Power Requirements:** 24 VDC, regulated ±10%.  
**Mounting Orientation:** Diaphragm in vertical position. Consult factory for other position orientations.  
**Set Point Adjustment:** Adjustable knobs on face.  
**Agency Approvals:** CE.

**SWITCH SPECIFICATIONS 3000MRS**  
**Switch Type:** Each set point has a solid state relay.  
**Switching Voltage:** 20-280 VAC (47-63 Hz).  
**Switching Current:** 1.0 amp (AC) max., 0.01 mA (AC) min., (2) SPST NO.  
**Electrical Connections:** 18" (46 cm) cable assembly with 6 conductors, optional lengths to 100' (30.5 m).  
**Power Requirements:** 24 VDC, regulated ±10%.  
**Mounting Orientation:** Diaphragm in vertical position. Consult factory for other position orientations.  
**Set Point Adjustment:** Adjustable knobs on face.  
**Agency Approvals:** CE.

**ACCESSORIES**

Model	Description
A-298	Flat aluminum bracket for flush mounting 3000MR/MRS
A-370	Mounting bracket flush mount 3000MR/MRS bracket. Bracket is then surface mounted. Steel with gray hammertone epoxy finish
A-600	R/C snubber recommended for inductive loads like a solenoid or contactor

**ACCESSORIES - STANDARD**

Description
Mounting ring, snap ring, 18" (46 cm) cable assembly, (2) 3/16" tubing to 1/8" NPT adapters, (2) 1/8" NPT pipe plugs, (4) 6-32 x 1-1/4" RH machine screws (panel mounting), (3) 6-32 x 5/16" RH machine screws (surface mounting)

**OPTIONS**

To order add suffix:	Description
-SS	304 brushed stainless steel bezel. *Backward compatible with standard Magnehelic® gage installation diameter
<b>Example:</b> 3001MR-SS	
-TAMP	Tamper-proof knobs; require spanner key (supplied) to change set points
-LT	Low temperature option; for use under 20°F (-6.7°C)
-MP	Medium pressure; increases maximum rated pressure to 35 psig (2.41 bar)
-HP	High pressure; increases maximum rated pressure to 80 psig (5.5 bar)
-WP	Weatherproof housing option
-NIST	NIST traceable calibration certificate
<b>Example:</b> 3001MR-NIST	

# ATEX/IECEx APPROVED PHOTOHELIC® SWITCH/GAGES WITH 24 VDC POWER

3000MR or 3000MRS Series in Flame-Proof ATEX/IECEx Enclosures

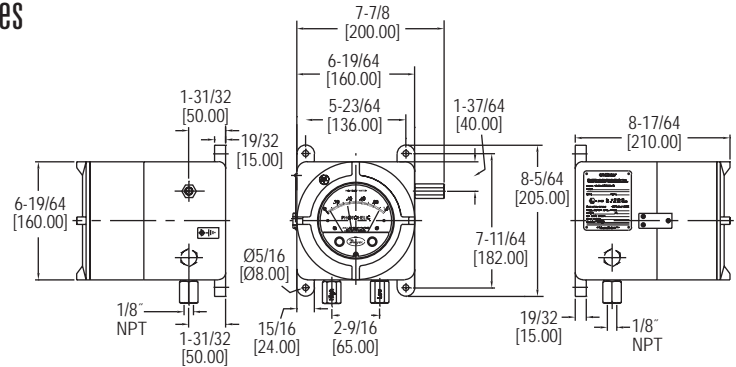

Using solid state technology, the Series AT23000MR & AT23000MRS ATEX/IECEx Approved Photohelic® Switch/Gage with 24 VDC Power combines the functions of a precise, highly repeatable differential pressure switch with a large easy-to-read analog pressure gage. Gage reading is unaffected by switch operation and will indicate accurately even if power is interrupted. AT23000MR series employ versatile electromechanical relays with low amperage ratings-ideal for dry circuits. For applications requiring high cycle rates, choose AT23000MRS models with SPST (NO) solid state relays. Easy to adjust set point indicators are controlled by knobs located on the gage face (accessible opening case after de-energizing instrument). All models provide both low and high limit control. Compatible with air and other non-combustible, non-corrosive gases, they can be used in systems with pressures to 25 psig (1.725 bar). Optional construction is available for use to either 35 psig (2.42 bar) or 80 psig (5.51 bar). Flame-proof enclosures are available with glass window which allows for viewing of set point needles and process pressure. Compatible with air and other non-combustible, non-corrosive gases, they can be used in systems with pressures to 25 psig (1.725 bar). Optional construction is available for use to either 35 psig (2.42 bar) or 80 psig (5.51 bar).

**FEATURES/BENEFITS**

- Gage reading unaffected by switch operation and will continue to read pressure even during power loss
- Zero and range adjustments outside of gage means no disassembly in normal service
- Solid-state design allows for switching in high cycle rate applications without degradation
- Flame-proof enclosure with optional glass window and aluminum housing protects the device in hazardous areas while giving local visibility to process pressure and set point status

**APPLICATIONS**

- Hazardous area pressure measurement and switching
- Pneumatic conveying
- Air conditioning systems
- Clean rooms
- Fume exhaust systems

**Attention:** Check local safety rules and warnings on unit and manual for a correct use of the instrument in hazardous area.

RANGE CHART					
Model	Range in w.c.	Minor Divis.	Model	Range, Pa	Minor Divis.
3000-00	0 to 0.25	.005	3000-60PA	0 to 60	2.0
3000-0	0 to 0.5	.01	3000-125PA	0 to 125	5.0
3001	0 to 1.0	.02	3000-250PA	0 to 250	5.0
3002	0 to 2.0	.05	3000-500PA	0 to 500	10.0

MODEL CHART												
Example	AT2	3001	MR	-X	X	X	-A	B	1	X	T2	AT23001MR-XXX-AB1XT2
Housing	AT2											ATEX/IECEx approved Photohelic® switch/gages
Range		3XXX										Specify range by using Photohelic® model number. See range chart.
Relay			MR MRS									Electromechanical relay Solid state relay
Pressure Rating				X MP HP								Standard -25 in Hg to 25 psig Medium pressure max. static 35 psig High pressure max. static 80 psig
Construction					X							Standard silicone construction
Temperature Rating						X LT						Standard temperature 20 to 120°F Low temperature to -20°F
Housing Material							A					Aluminum
Cover								B O				Blind Glass top cover
Process Connection									1 2			1/8" NPT female brass ports 1/8" NPT female SS ports
Overpressure Plug										X OPV		Standard without overpressure relief valve Overpressure relief valve Material same as ports
Tag											T2	SS information label

**SPECIFICATIONS**

**Service:** Air and non-combustible, compatible gases.  
**Wetted Materials:** Consult factory.  
**Housing Material:** Aluminum.  
**Finishing:** Texture epoxy coat RAL7038.  
**Accuracy:** ±2% of FS at 70°F (21.1°C). ±3% on -0, -60 Pa and ±4% on -00 models.  
**Pressure Limits:** -20 in Hg to 25 psig (-0.677 bar to 1.72 bar). MP option: 35 psig (2.41 bar), HP option: 80 psig (5.52 bar).  
**Temperature Limits:** 20 to 120°F. (-6.67 to 48.9°C). Option LT low temperature to -20°F (28.8°C) (**Note:** Product temperature limits differ from case).  
**Power Requirements:** 24 VDC, regulated ±10%.  
**Electrical Wiring:** Screw terminals.  
**Mounting Orientation:** Diaphragm in vertical position.  
**Enclosure Rating:** IP66. IP65 with option OPV, overpressure relief valve.  
**Process Connections:** 1/8" NPT female brass (SS optional). In presence of acetylene it is necessary to use SS.  
**Electrical Connections:** Two 1/2" NPT female. Cable gland not included.  
**Dial Size:** 4" (101.6 mm).  
**Set Point Adjustment:** Adjustable knobs on face behind enclosure cover. Follow instructions and safety warnings to open cover.  
**Weight:** 12.5 lb (5.7 kg).  
**ATEX Certificate:** BVI 14ATEX0072.  
**Agency Approvals:** ATEX Compliant **CE** 1370 **Ex** II 2G Ex d IIC T6 Gb / II 2D Ex tb IIIC T85°C Db, -60°C≤Tamb≤+60°C IECEx Compliant: Ex d IIC T6 Gb / Ex tb IIIC T85°C Db.

**SWITCH SPECIFICATIONS (3000MR)**

**Switch Type:** Each set point has 1 Form C relay (SPDT).  
**Relay Contacts:** (resistive load) 1 Form C rated 1.0 A @ 30 VDC, 0.3 A @ 110 VDC or 0.5 A @ 125 VAC. Gold over clad silver - suitable for dry circuits.

**SWITCH SPECIFICATIONS (3000MRS)**

**Switch Type:** Each set point has a solid state relay.  
**Switching Voltage:** 20 to 280 VAC (47 to 63 Hz).  
**Switching Current:** 1.0 amp (AC) max., 0.01 mA (AC) min., (2) SPST NO.



# MINI-PHOTOHELIC® DIFFERENTIAL PRESSURE SWITCH/GAGE

## Compact, Low Cost Switch Gage

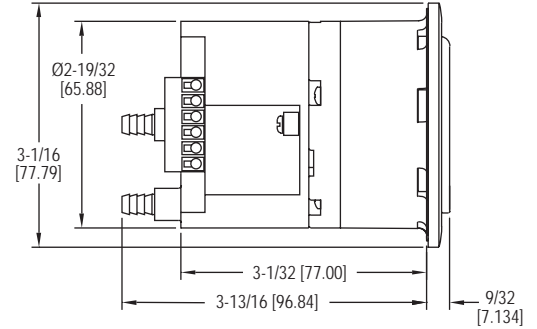
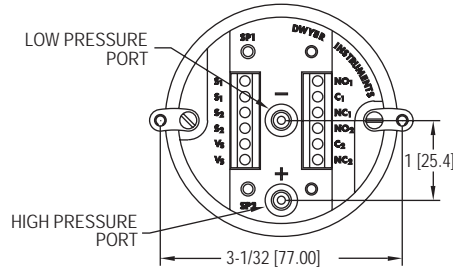

The **Series MP Mini-Photohelic® Differential Pressure Switch/Gage** combines the time proven Minihelic® II differential pressure gage with two SPDT switching set points. The Mini-Photohelic® switch/gage is designed to measure and control positive, negative, or differential pressures consisting of non-combustible and non-corrosive gases. Gage reading is independent of switch operation. Switching status is visible by LED indicators located on the front and rear of the gage. Set points are adjusted with push-buttons on the back of the unit.

**FEATURES/BENEFITS**

- Gage reading unaffected by switch operation and will continue to read pressure even during power loss
- Visible switch status LED provides indication of set point switching state
- Compact design but with the power of larger devices can meet the same application specifications

**APPLICATIONS**

- Fume hoods
- Dust collection
- Pneumatic conveying
- Clean room

MODEL CHART			
Model	Range, Inches of Water	Model	Range, Pa
MP-000	0-0.5	MP-125PA	0-125
MP-001	0-1.0	MP-250PA	0-250
MP-002	0-2.0	MP-500PA	0-500
MP-003	0-3.0		
MP-005	0-5.0	<b>Model</b>	<b>Range,</b>
MP-010	0-10	MP-1KPA	0-1
MP-020	0-20	MP-3KPA	0-3

OPTIONS	
To order add suffix:	Description
-NPT	1/8" male NPT connections
<b>Example:</b> MP-000-NPT;	<b>Note:</b> Allow additional lead time
-NIST	NIST traceable calibration certificate
<b>Example:</b> MP-005-NIST	

ACCESSORIES	
Model	Description
A-301	Static pressure tip for 1/4" metal tubing connection
A-302	Static pressure tip for 3/16" and 1/8" I.D. plastic or rubber tubing
A-302F-A	303 SS static pressure tip with mounting flange; for 3/16" ID rubber or plastic tubing; 4" insertion depth; includes mounting screws
A-489	4" straight static pressure tip with flange

**SPECIFICATIONS**

**GAGE SPECIFICATIONS**

**Service:** Air and non-combustible, compatible gases.  
**Wetted Materials:** Consult factory.  
**Accuracy:** ±5% of FS @ 70°F (21.1°C). Gage face mounted in vertical position.  
**Pressure Limits:** 30 psig (2.067 bar).  
**Temperature Limits:** 20 to 120°F (-6.7 to 49°C).  
**Process Connections:** Barbed for 3/16" ID tubing (STD); 1/8" male NPT (optional).  
**Size:** 4-1/8" (104.78 mm) depth x 3-1/16" (77.79 mm) diameter.  
**Weight:** 23 oz (652 g).

**SWITCH SPECIFICATIONS**

**Switch Type:** (2) SPDT relays.  
**Electrical Rating:** 5 A @ 120/240 VAC resistive; 5 A @ 30 VDC.  
**Electrical Connections:** Screw type terminal block. Accepts 22-12 AWG wire.  
**Power Requirements:** 24 VDC / 24 VAC 50/60 Hz 4 watts.  
**Mounting Orientation:** Gage face in vertical position.  
**Set Point Adjustment:** Push-buttons.  
**Standard Accessories:** (2) mounting screws, (1) .050" hex allen wrench.  
**Agency Approvals:** CE, cULus.

Differential Pressure Gages/Switches, Dial





# HVAC DIFFERENTIAL PRESSURE SWITCHES

## With Dual Scale Field Adjustable Set Point Knob

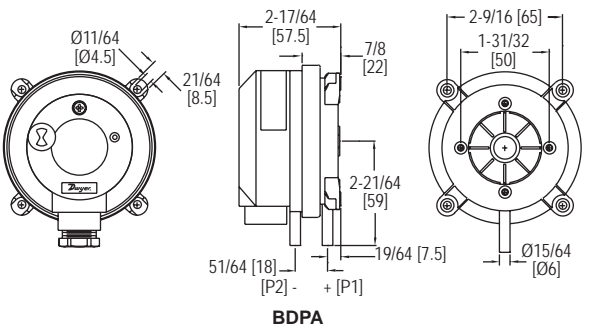
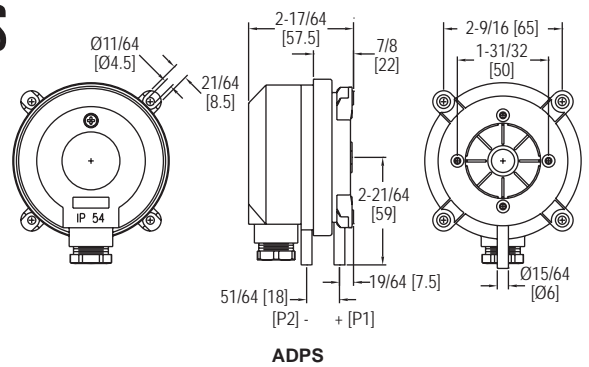
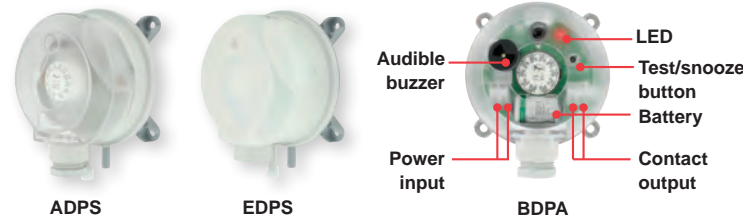

The **Series ADPS/EDPS/BDPA HVAC Differential Pressure Switches** are designed for pressure, vacuum, and differential pressures. The dual scaled adjustment knob in inches water column and pascals allows changes to the switching pressure to be made without a pressure gage. The ADPS/EDPS/BDPA are available with settings from 0.08 in w.c. (20 Pa) up to 20 in w.c. (5000 Pa). The silicone diaphragm and PA 6.6 body make the series ADPS ideal for use with air and other noncombustible gases. Series EDPS models meet UL508 and are constructed of plenum rated plastics. The series BDPA Adjustable Differential Pressure Alarms offer a versatile range of configurations allowing utilization of their many features including buzzer and LED notification, and battery or line powered. The compact size, adjustment knob and low cost make the ADPS/EDPS/BDPA the perfect choice for HVAC applications.

**FEATURES/BENEFITS**

- Adjustment knob changes switching pressure easily with a pressure gage reducing components for application
- Low cost device makes it an excellent solution in BAS and HVAC applications requiring duct control and monitoring
- Relay contact allows simple integration with DDC or building systems

**APPLICATIONS**

- Air filter and ventilator monitoring
- Industrial cooling circuits
- Fire-protection damper control
- Ventilation duct monitoring
- Fan heater overheating protection
- Heat exchanger frost protection

MODEL CHART - ADPS			
Model	Set Point Range in w.c. (Pa)	Approx. Dead Band @ Min Set Point in w.c. (Pa)	Approx. Deadband @ Max Set Point in w.c. (Pa)
ADPS-08-2-N	0.08 to 1.20 (20-300)	0.04 (10)	0.05 (12)
ADPS-04-2-N	0.12 to 1.60 (30-400)	0.06 (15)	0.09 (23)
ADPS-03-2-N	0.20 to 2.00 (50-500)	0.08 (20)	0.09 (23)
ADPS-05-2-N	0.80 to 4.00 (200-1000)	0.4 (100)	0.5 (130)
ADPS-06-2-N	2.00 to 10.00 (500-2500)	0.6 (150)	0.8 (200)
ADPS-07-2-N	4.00 to 20.00 (1000-5000)	1.0 (250)	1.4 (350)

**Note:** For optional 1/2" NPT conduit connection, change -2-N to -1-N. Models that include installer kit add -C to the end of the model number (-2-N cable gland models only). Installer kit includes two static tips and 7 ft of PVC tubing. Order installer kit separately with 1/2" NPT conduit connection models. See A-481 in the accessories list. Consult factory for bulk packaging option.

MODEL CHART - EDPS			
Model	Set Point Range in w.c. (Pa)	Approx. Dead Band @ Min Set Point in w.c. (Pa)	Approx. Dead Band @ Max Set Point in w.c. (Pa)
EDPS-08-1-N	0.08 to 1.20 (20-300)	0.04 (10)	0.05 (12)
EDPS-04-1-N	0.12 to 1.60 (30-400)	0.06 (15)	0.09 (23)
EDPS-03-1-N	0.20 to 2.00 (50-500)	0.08 (20)	0.09 (23)
EDPS-05-1-N	0.80 to 4.00 (200-1000)	0.4 (100)	0.5 (130)
EDPS-06-1-N	2.00 to 10.00 (500-2500)	0.6 (150)	0.8 (200)
EDPS-07-1-N	4.00 to 20.00 (1000-5000)	1.0 (250)	1.4 (350)

**Note:** For optional M20 cable gland connection, change -1-N to -2-N.

MODEL CHART - BDPA			
Model	Set Point Range in w.c. (Pa)	Approx. Dead Band @ Min Set Point in w.c. (Pa)	Approx. Dead Band @ Max Set Point in w.c. (Pa)
BDPA-08-2-N	0.08 to 1.20 (20 to 300)	0.04 (10)	0.05 (12)
BDPA-04-2-N	0.12 to 1.60 (30 to 400)	0.06 (15)	0.09 (23)
BDPA-03-2-N	0.20 to 2.00 (50 to 500)	0.08 (20)	0.09 (23)
BDPA-05-2-N	0.80 to 4.00 (200 to 1000)	0.4 (100)	0.5 (130)
BDPA-06-2-N	2.00 to 10.00 (500 to 2500)	0.6 (150)	0.8 (200)
BDPA-07-2-N	4.00 to 20.00 (1000 to 5000)	1.0 (250)	1.4 (350)

**SPECIFICATIONS**

**Service:** Air and non-combustible, compatible gases.  
**Wetted Materials:** ADPS: Diaphragm material: Silicone; Housing material: POM; Switch body: PA 6.6; Cover: Polystyrene; EDPS: Diaphragm material: Silicone; Housing material: Switch body: PA 6.6; Cover: Polystyrene; Materials UL 94 V-0 rated.  
**Temperature Limits:** Process and ambient temperature from -4 to 185°F (-20 to 85°C).  
**Pressure Limits:** Max. operating pressure: 40 in w.c. (10 kPa) for all pressure ranges.  
**Switch Type:** Single-pole double-throw (SPDT).  
**Electrical Rating:** Max. 1.5 A res./0.4 A ind./250 VAC, 50/60 Hz; Max. switching rate: 6 cycles/min.  
**Electrical Connections:** Push-on screw terminals. M20x1.5 with cable strain relief or optional 1/2" NPT.  
**Process Connections:** 5/16" (7.94 mm) outside diameter tubing, 1/4" (6.0 mm) inside diameter tubing.  
**Enclosure Rating:** NEMA 13 (IP54).  
**Mounting Orientation:** Vertically, with pressure connections pointing downwards.  
**Mechanical Working Life:** Over 10<sup>6</sup> switching operations.  
**Weight:** 5.6 oz (160 g).  
**Agency Approvals:** ETL approved to UL508 and CSA C22.2#14 (EDPS only).

**ACCESSORIES**

Model	Description
A-288	"L" type metal mounting bracket with screws
A-289	"S" type metal mounting bracket with screws
A-480	Plastic static pressure tip
A-481	Installer kit, includes 2 plastic static pressure tips & 7' (2.1 m) of PVC tubing
A-489	4" straight static pressure tip with flange



A-480

# ATEX/IECEX APPROVED ADPS ADJUSTABLE DIFFERENTIAL PRESSURE SWITCH

The ADPS in Flame-Proof ATEX/IECEX Enclosure

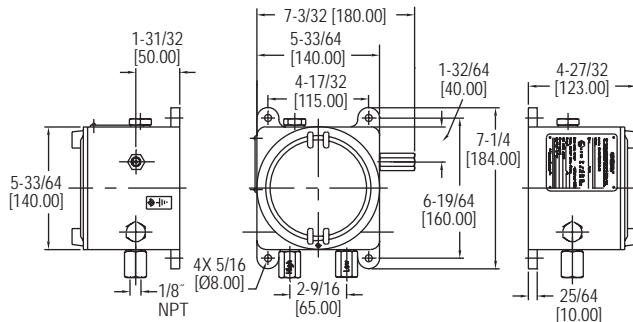

The **Series AT1ADPS ATEX/IECEX Approved ADPS Adjustable Differential Pressure Switch** is designed for pressure, vacuum, and differential pressure applications in hazardous areas. The dual scaled adjustment knob in inches water column and Pascals allows changes to the switching pressure to be made without a pressure gage. The switch is available with settings from 0.08 in w.c. (20 Pa) up to 16 in w.c. (4000 Pa). The silicone diaphragm makes this series ideal for use with air and other noncombustible gases. Flame-proof enclosures are available in aluminum and can include a glass window for viewing set point status on the adjustment knob.

**FEATURES/BENEFITS**

- Flame-proof enclosure with optional glass window and aluminum housing protects the device in hazardous areas while giving local visibility to set point status

**APPLICATIONS**

- Hazardous area pressure switch
- Air filter and ventilator monitoring
- Ventilation duct monitoring
- Industrial cooling circuits
- Fan heater overheating protection
- Fire-protection damper control
- Heat exchanger frost protection

**SPECIFICATIONS**

**Service:** Air and non-combustible, compatible gases.  
**Wetted Materials:** Diaphragm material: Silicone; Housing material: Switch body: PA 6.6 and POM; Cover: Polystyrene; Brass or SS depending on pressure connections chosen.  
**Temperature Limits:** Process and ambient temperature from -4 to 185°F (-20 to 85°C) (**Note:** Product temperature limits differ from case).  
**Pressure Limits:** 40 in w.c. (10 kPa).  
**Switch Type:** SPDT.  
**Electrical Rating:** Standard: Max. 1.5 A @ 250 VAC, max. switching rate: 6 cycles/min.  
**Set Point Adjustment:** Hand knob on pressure switch inside case. (De-energize before opening case).  
**Mounting Orientation:** Vertically, with pressure connections pointing downwards.  
**Mechanical Working Life:** Over 10<sup>6</sup> switching operations.  
**Enclosure Rating:** IP66. IP65 with option OPV, overpressure relief valve.  
**Housing Material:** Aluminum.  
**Finishing:** Texture epoxy coat RAL7038.  
**Process Connections:** 1/8" NPT female brass (SS optional). In presence of acetylene it is necessary to use SS.  
**Electrical Connections:** Two 1/2" NPT female. Cable gland not included.  
**Weight:** 7 lb (3.2 kg).  
**ATEX Certificate:** BVI 14ATEX0072.  
**Agency Approvals:** ATEX Compliant 1370 II 2G Ex d IIC T6 Gb / II 2D Ex tb IIC T85°C Db, -60°C ≤ Tamb ≤ +60°C IECEx Compliant: Ex d IIC T6 Gb / Ex tb IIC T85°C Db.

MODEL CHART										
Example	AT1ADPS	-08	-2	-N	-A	O	1	X	T2	AT1ADPS-08-2-N-AO1XT2
Series	ATEX/IECEX approved ADPS adjustable differential pressure switch									
Range		08								.08 to 1.2 in w.c. (20 to 300 Pa)
		04								.12 to 1.6 in w.c. (30 to 400 Pa)
		03								.2 to 2 in w.c. (50 to 500 Pa)
		05								.8 to 4 in w.c. (200 to 1000 Pa)
		06								2 to 10 in w.c. (500 to 2500 Pa)
		07								4 to 20 in w.c. (1000 to 5000 Pa)
Connection			2							Internal cable gland
Switch				N						1.5 A @ 250 VAC
Housing Material					A					Aluminum
Cover						B				Blind
						O				Glass top cover
Process Connection							1			1/8" NPT female brass ports
							2			1/8" NPT female SS ports
Overpressure Plug								X		Standard without overpressure relief valve
								OPV		Overpressure relief valve
										Material same as ports
Tag									T2	SS information label

# LOW DIFFERENTIAL PRESSURE SWITCH FOR GENERAL INDUSTRIAL SERVICE

Set Points from 0.07 in w.c. to 85 in w.c. Repetitive Accuracy within 2%

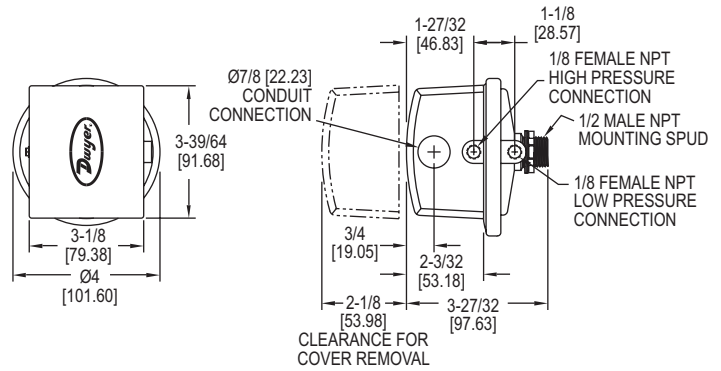

Essential for industrial environments, the **Series 1800 Low Differential Pressure Switch for General Industrial Service** combines small size and low price with 2% repeatability for all but the most demanding applications. Set point adjustment inside the mounting stud permits mounting the switch on one side of a wall or panel with adjustment easily accessible on the opposite side. UL and CSA listed, and FM approved.

### FEATURES/BENEFITS

- Compact size and repeatability provide a high-value switch useful in many industrial applications
- Designed for panel and wall mounting to easily meet mounting requirements in most industrial settings
- Pressure ranges from 0.07 in w.c. to 85 in w.c. make this switch suitable for a wide range of applications

### APPLICATIONS

- Process applications
- Mechanical equipment control

OPTIONS
<b>Weatherproof Housing</b> 16 ga. steel enclosure with gasketed cover (NEMA 4, IP66) for wet or oily conditions. Withstands 200 hour salt spray test. Wt. 5-1/2 lb (2.5 kg). Switch must be factory installed. <b>Note:</b> To order, change 1823 base number to 1824 and add -WP suffix. <b>Example:</b> 1824-1-WP
<b>Explosion-Proof Housing</b> Cast iron base with aluminum cover. Rated Class I, Div. 1 & 2, Group D; Class II, Div. 1 & 2, Groups E, F, G; Class III and NEMA 7 CD, 9 EFG. Wt. 7-1/2 lb (3.4kg). Switch must be factory installed. <b>Note:</b> To order, change 1823 base number to 1824 and add -EXPL suffix. <b>Example:</b> 1824-1-EXPL
<b>MIL Environmental Construction</b> Unlisted Model 1820 can be furnished with a special sealed snap switch for protection against high humidity, fungus and/or military applications. Similar to Model 1823 except deadband is slightly greater and some lower setpoints may not be possible. <b>Note:</b> To order, add -MIL suffix. <b>Example:</b> 1820-2-MIL

SPECIFICATIONS
<b>Service:</b> Air and non-combustible, compatible gases.
<b>Wetted Materials:</b> Consult factory.
<b>Temperature Limits:</b> -30 to 180°F (-34 to 82.2°C); 1823-00: -20 to 180°F (-28.9 to 82.2°C).
<b>Pressure Limits:</b> 10 psig (68.95 kPa) continuous, 25 psig (172.4 kPa) surge.
<b>Switch Type:</b> Single-pole double-throw (SPDT).
<b>Repeatability:</b> ±2%.
<b>Electrical Rating:</b> 15 A @ 120-480 VAC, 60 Hz. Resistive 1/8 HP @ 125 VAC, 1/4 HP @ 250 VAC, 60 Hz. De-rate to 10 A for operation at high cycle rates.
<b>Electrical Connections:</b> 3 screw type, common, normally open and normally closed.
<b>Process Connections:</b> 1/8" female NPT.
<b>Mounting Orientation:</b> Diaphragm in vertical position. Consult factory for other position orientations.
<b>Set Point Adjustment:</b> Screw type inside mounting spud.
<b>Weight:</b> 1 lb 5 oz (595 g).
<b>Agency Approvals:</b> CE, CSA, FM, UL. Optional-EXPL explosion-proof enclosure does not possess any agency approvals.

MODEL CHART			
Model	Operating Range, in w.c.	Approximate Deadband	
		At Min. Set Point	At Max. Set Point
1823-00	0.07 to 0.22	0.05	0.05
1823-0	0.15 to 0.5	0.06	0.06
1823-1	0.3 to 1.0	0.08	0.08
1823-2	0.5 to 2.0	0.10	0.12
1823-5	1.5 to 5.0	0.14	0.28
1823-10	2.0 to 10	0.18	0.45
1823-20	3 to 22	0.35	0.70
1823-40	5 to 44	0.56	1.10
1823-80	9 to 85	1.30	3.0

ACCESSORIES	
Model	Description
A-389	Mounting bracket; 16 ga. steel, zinc plated and dichromate dipped for corrosion resistance; provides rugged, permanent mounting and speeds installation
A-489	4" straight static pressure tip with flange
A-491	6" straight static pressure tip with flange
A-493	8" straight static pressure tip with flange
A-302F-A	303 SS static pressure tip with mounting flange; for 3/16" ID rubber or plastic tubing; 4" insertion depth; includes mounting screws
A-302F-B	303 SS static pressure tip with mounting flange; for 3/16" rubber or plastic tubing; 6" insertion depth; includes mounting screws
A-302F-C	303 SS static pressure tip with mounting flange; for 3/16" rubber or plastic tubing; 8" insertion depth; includes mounting screws

Process Tubing Options: See page 455 (Gage Tubing Accessories)

# ATEX/IECEX APPROVED 1823 DIFFERENTIAL PRESSURE SWITCH

The 1823 in Flame-Proof ATEX/IECEX Enclosure

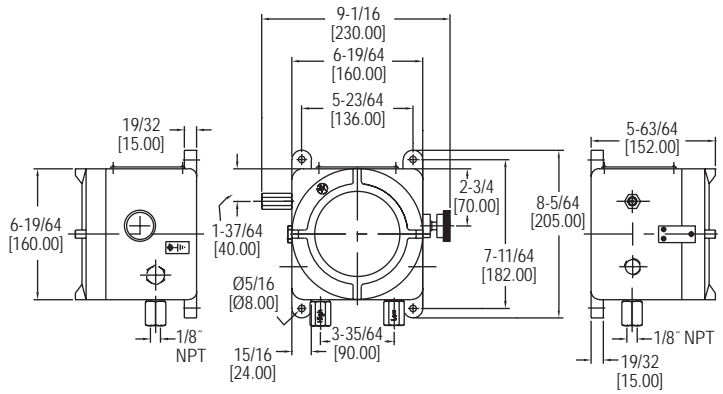

Essential for industrial environments, the **Series AT21823 ATEX/IECEX Approved 1823 Differential Pressure Switch** combines small size with 2% repeatability. Set point adjustment inside the switch allows for set point settings across 9 ranges from the low of .07 in w.c. to a maximum 85 in w.c. differential pressure. Series AT21823 flame-proof enclosures are available in aluminum and are ideal for low pressure hazardous area applications. Various housing options such as an overpressure relief valve or external set point adjustment knob are available. External set point knob allows adjustment without opening the enclosure.

**FEATURES/BENEFITS**

- Compact size and repeatability, provides a high-value switch for many industrial applications
- External set point knob provides easy access that simplifies making adjustments without opening enclosure
- Flame-proof enclosure protects the device in hazardous areas

**APPLICATIONS**

- Hazardous area pressure switch
- Process applications
- Mechanical equipment control

**Attention:** Check local safety rules and warnings on unit and manual for a correct use of the instrument in hazardous area.

**SPECIFICATIONS**

**Service:** Air and non-combustible, compatible gases.  
**Wetted Materials:** Consult factory.  
**Temperature Limits:** -30 to 180°F (-34 to 82.2°C); 1823-00, -20 to 180°F (-28.9 to 82.2°C) (**Note:** Product temperature limits differ from case).  
**Pressure Limits:** 10 psig (68.95 kPa) continuous, 25 psig (172.4 kPa) surge.  
**Switch Type:** SPDT.  
**Repeatability:** ±2% FS.  
**Electrical Rating:** 15 A @ 120-480 VAC, 60 Hz. Resistive 1/8 HP @ 125 VAC, 1/4 HP @ 250 VAC, 60 Hz. De-rate to 10 A for operation at high cycle rates.  
**Mounting Orientation:** Diaphragm in vertical position.  
**Set Point Adjustment:** Screw type inside mounting spud internal to switch. External set point adjustment knob optional.  
**Enclosure Rating:** IP66. IP65 with option OPV, overpressure relief valve or external set point adjustment knob.  
**Housing Material:** Aluminum.  
**Finishing:** Texture epoxy coat RAL7038.  
**Process Connections:** 1/8" NPT female brass (SS optional). In presence of acetylene it is necessary to use SS.  
**Electrical Connections:** Two 1/2" NPT female. Cable gland not included. Weight: 11.9 lb (5.4 kg).  
**ATEX Certificate:** BVI 14ATEX0072.  
**Agency Approvals:** ATEX Compliant 1370 II 2G Ex d IIC T6 Gb / II 2D Ex tb IIIC T85°C Db, -60°C ≤ Tamb ≤ +60°C IECEx Compliant: Ex d IIC T6 Gb / Ex tb IIIC T85°C Db.

**MODEL CHART**

Example	AT21823	-00	-A	O	K1	1	X	T2	AT21823-00-AOK11XT2
<b>Series</b>	AT21823								ATEX/IECEX approved 1823 differential pressure switch
<b>Range</b>		00 0 1 2 5 10 20 40 80							.08 to .22 in w.c. (18 to 56 Pa) .15 to .5 in w.c. (38 to 127 Pa) .3 to 1 in w.c. (76 to 254 Pa) 0.5 to 2 in w.c. (127 to 508 Pa) 1.5 to 5 in w.c. (381 to 1270 Pa) 2 to 10 in w.c. (.5 to 2.5 kPa) 3 to 22 in w.c. (.76 to 5.6 kPa) 5 to 44 in w.c. (1.27 to 11.17 kPa) 9 to 85 in w.c. (2.28 to 21.6 kPa)
<b>Housing Material</b>			A						Aluminum
<b>Cover</b>				B O					Blind Glass top cover
<b>Set point Adjustment</b>					K1 K2				Without external set point adjustment knob With external set point adjustment knob
<b>Process Connection</b>						1 2			1/8" NPT female brass ports 1/8" NPT female SS ports
<b>Overpressure Plug</b>							X OPV		Standard without overpressure relief valve Overpressure relief valve Material same as ports
<b>Tag</b>								T2	SS information label



# COMPACT LOW DIFFERENTIAL PRESSURE SWITCHES

Set Points from 0.07 to 20 in w.c. Repetitive Accuracy within 3%



Series 1910 switch with conduit enclosure off. Shows electric switch and set point adjustment screw located on same side for easy installation.

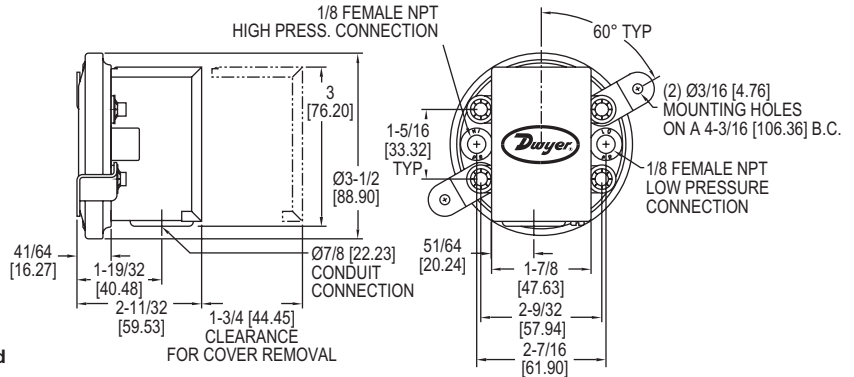

The Dwyer-engineered force-motion amplifier increases the leverage of diaphragm movement and results in a switch with excellent sensitivity and repeatability.



Our most popular **Series 1900 Compact Low Differential Pressure Switches** combine advanced design and precision construction to make these switches able to perform many of the tasks of larger, costlier units. Designed for air conditioning service, they also serve many fluidics, refrigeration, oven and dryer applications. Series 1900 switches have set points from 0.07 to 20 in w.c. (1.8 to 508 mm). Set point adjustment is easy with range screw located inside conduit enclosure. Internal location helps prevent tampering. UL, CE and CSA listed, and FM approved. For use with air or compatible gases.

### FEATURES/BENEFITS

- Compact size and repeatability, provides a high-value switch for many industrial and OEM applications
- Wide range of models from 0.07 in w.c. to 20 in w.c. can meet exacting OEM specifications for a low pressure switch
- Range screw protected inside enclosure provides simplifies making adjustments but prevents tampering

### APPLICATIONS

- Air conditioning refrigeration coil icing detection; defrost cycle initiation
- Clogged filter detection
- Variable air volume controller

Model	Operating Range in w.c.	Approximate Deadband	
		At Min. Set Point	At Max. Set Point
1910-00	0.07 to 0.15	0.04	0.04
1910-0	0.15 to 0.5	0.10	0.10
1910-1	0.40 to 1.6	0.15	0.16
1910-5	1.40 to 5.5	0.30	0.30
1910-10	3.0 to 11.75	0.40	0.40
1910-20	4.0 to 20.0	0.40	0.50

Model	Description
A-399	Duct pressure monitor kit; for use with standard or manual reset model switches; includes mounting flange, tubing and adapters
A-329	Street ell; brass adapter for applications requiring right angle connections; two required for differential pressures
A-302F-A	303 SS static pressure tip with mounting flange; for 3/16" ID rubber or plastic tubing; 4" insertion depth; includes mounting screws
A-489	4" straight static pressure tip with flange

SPECIFICATIONS	
<b>Service:</b> Air and non-combustible, compatible gases.	<b>Electrical Connections:</b> 3 screw type, common, normally open and normally closed.
<b>Wetted Materials:</b> Consult factory.	<b>Process Connections:</b> 1/8" female NPT.
<b>Temperature Limits:</b> -30 to 180°F (-34 to 82.2°C).	<b>Mounting Orientation:</b> Diaphragm in vertical position. Consult factory for other position orientations.
<b>Pressure Limits:</b> 45 in w.c. (11.2 kPa) continuous, 10 psig (68.95 kPa) surge.	<b>Set Point Adjustment:</b> Screw type inside conduit enclosure.
<b>Switch Type:</b> Single-pole double-throw (SPDT).	<b>Weight:</b> 1 lb 4.5 oz (581 g).
<b>Repeatability:</b> ±3%.	<b>Agency Approvals:</b> CE, CSA, FM, and UL. Optional-EXPL explosion-proof enclosure does not possess any agency approvals.
<b>Electrical Rating:</b> 15 A @ 120-480 VAC, 60 Hz. Resistive 1/8 HP @ 125 VAC, 1/4 HP @ 250 VAC, 60 Hz. Derate to 10 A for operation at high cycle rates.	

OPTIONS
<b>Weatherproof Housing</b> 16 ga. steel enclosure with gasketed cover (NEMA 4, IP66) for wet or oily conditions. Withstands 200 hour salt spray test. Wt. 5-1/2 lb (2.5 kg). Switch must be factory installed. <b>Note:</b> To order, change 1910 base number to 1911, add -WP suffix. <b>Example:</b> 1911-1-WP
<b>Explosion-Proof Housing</b> Cast iron base with brass cover. Rated Class I, Groups D; Class II, Div. 2, Groups E, F, G; Class III and NEMA 7, 9 NEMA 3. (7 lb). Switch must be factory installed. <b>Note:</b> To order, change 1910 base number to 1911, add -EXPL suffix. <b>Example:</b> 1911-1-EXPL
<b>Manual Reset Option (Model 1900 MR)</b> Includes special snap switch which latches on pressure increase above the setpoint. Switch must be manually reset after pressure drops below the setpoint. Available on -1, -5, -10 or -20 ranges only. Option is not UL, CSA or FM listed. For use only in single positive pressure applications. <b>Note:</b> To order, change 1910 base number to 1900, add -MR suffix. <b>Example:</b> 1900-10-MR



### Manual reset option

USA: California Proposition 65  
⚠️WARNING: Cancer and Reproductive Harm - www.P65Warnings.ca.gov

Process Tubing Options: See page 455 (Gage Tubing Accessories)

# ATEX/IECEx APPROVED 1910 DIFFERENTIAL PRESSURE SWITCH

The 1910 in Flame-Proof ATEX/IECEx Enclosure

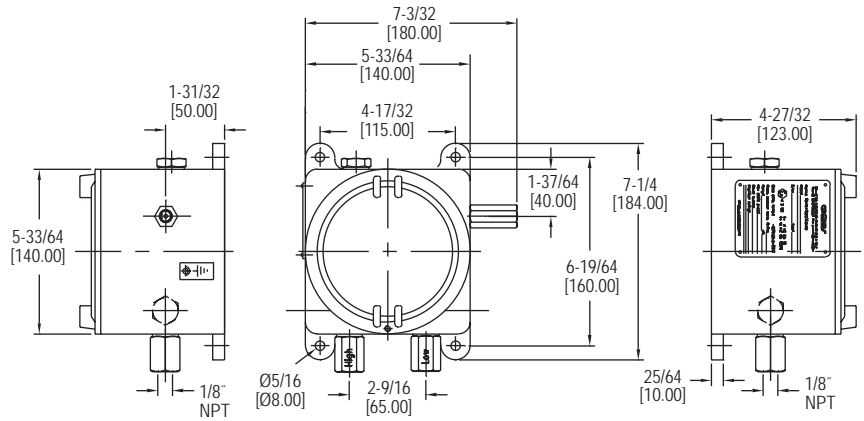

**Series AT11910 ATEX/IECEx Approved 1910 Differential Pressure Switch** is our most popular switch and is now available in a flame-proof package. This pressure switch combines advanced design and precision construction to make these switches able to perform many of the tasks of larger, costlier units. For air and non-combustible compatible gases, the AT11910 Series switches have set points from 0.07 to 20 in w.c. (1.8 to 508 mm). Set point adjustment is easy with range screw located inside the switch enclosure. Series AT11910 enclosures are available in aluminum enclosures and ideal for low pressure, hazardous area applications.

**FEATURES/BENEFITS**

- Flame-proof enclosure protects the device in hazardous areas
- Compact size and repeatability, provides a high-value switch for many industrial and OEM applications
- Wide range of models from 0.07 in w.c. to 20 in w.c. can meet exacting OEM specifications for a low pressure switch
- Range screw protected inside switch enclosure prevents tampering

**APPLICATIONS**

- Hazardous area low pressure applications
- Air conditioning refrigeration coil icing detection; defrost cycle initiation
- Clogged filter detection
- Variable air volume controller

**Attention:** Check local safety rules and warnings on unit and manual for a correct use of the instrument in hazardous area.

**SPECIFICATIONS**

**Service:** Air and non-combustible, compatible gases.  
**Wetted Materials:** Consult factory.  
**Temperature Limits:** -30 to 180°F (-34 to 82.2°C) (**Note:** Product temperature limits differ from case).  
**Pressure Limits:** 45 in w.c. (11.2 kPa) continuous, 10 psig (68.95 kPa) surge.  
**Switch Type:** SPDT.  
**Repeatability:** ±3% FS.  
**Electrical Rating:** 15 A @ 120 to 480 VAC, 60 Hz. Resistive 1/8 HP @ 125 VAC, 1/4 HP @ 250 VAC, 60 Hz. Derate to 10 A for operation at high cycle rates.  
**Mounting Orientation:** Diaphragm in vertical position.  
**Set Point Adjustment:** Screw type on pressure switch inside the enclosure accessible by hole with plug on housing. Set point regulation must be done with instrument de-energized. Follow instructions and safety warning to open cover.  
**Enclosure Rating:** IP66. IP65 with option OPV, overpressure relief valve.  
**Housing Material:** Aluminum.  
**Finishing:** Texture epoxy coat RAL7038.  
**Process Connections:** 1/8" NPT female brass (SS optional). In presence of acetylene it is necessary to use SS.  
**Electrical Connections:** Two 1/2" NPT female. Cable gland not included. Weight: 7.49 lb (3.4 kg).  
**ATEX Certificate:** BVI 14ATEX007.  
**Agency Approvals:** ATEX Compliant **CE** 1370 **Ex** II 2G Ex d IIC T6 Gb / II 2D Ex tb IIIC T85°C Db, -60°C ≤ Tamb ≤ +60°C IECEx Compliant: Ex d IIC T6 Gb / Ex tb IIIC T85°C Db.

MODEL CHART								
<b>Example</b>	AT11910	-00	-A	B	1	X	T2	AT11910-00-AB1XT2
<b>Series</b>	AT11910							ATEX/IECEx approved 1910 differential pressure switch
<b>Range</b>		00						.07 to .15 in w.c. (17.5 to 37 Pa)
		0						.15 to .55 in w.c. (37.5 to 137 Pa)
		1						.4 to 1.6 in w.c. (100 to 398 Pa)
		5						1.4 to 5.5 in w.c. (348.5 to 1368 Pa)
		10						3 to 11.75 in w.c. (747 to 2924 Pa)
		20						4 to 20 in w.c. (996 to 4977 Pa)
<b>Housing Material</b>			A					Aluminum
<b>Cover</b>				B				Blind
<b>Process Connection</b>					1			1/8" NPT female brass ports
					2			1/8" NPT female SS ports
<b>Overpressure Plug</b>						X		Standard without overpressure relief valve
						OPV		Overpressure relief valve
								Material same as ports
<b>Tag</b>							T2	SS information label

# MINIATURE PRESSURE SWITCH

Shock and Vibration Resistant, Lightweight and Compact, Gold Contacts

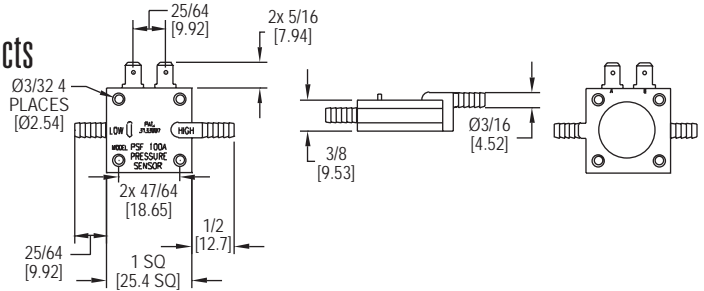

The **Series MDS Miniature Pressure Switch** is designed with a double diaphragm to protect false actuation due to shock and vibration. This low cost pressure switch has a minimum 20 million cycle life expectancy, and an extremely fast response time, making this an ideal device for OEM orders.

**FEATURES/BENEFITS**

- Low cost, long service life and fast response time is suitable for a wide range of OEM uses
- Lightweight but shock and vibration resistant for tough applications
- Gold contacts help ensure a clean connection without dirt or oxidation

**APPLICATIONS**

- Air proving
- Cleaning and purification
- Ventilation flow
- Heavy equipment and machinery
- Pressure monitoring
- Exhaust ducts

USA: California Proposition 65

⚠WARNING: Cancer and Reproductive Harm - www.P65Warnings.ca.gov

**SPECIFICATIONS**

**Switch Type:** SPST normally open.  
**Switching Media:** Air or compatible fluids on "high" side.  
**Pressure Limits:** Set point <3.0 in w.c.: 8 psi; Set point >3.0 in w.c.: 15 psi.  
**Current Rating:** Gold contact switch providing maximum 40 mA resistive load allowing for life in excess of 20 million cycles.  
**Temperature Limits:** 40 to 150°F (4 to 66°C).

**Electrical Connections:** Brass tab-type for use with quick disconnects.  
**Pressure Connections:** Two barbed ports for use with 1/8"-3/16" ID tubing.  
**Housing:** Polycarbonate.  
**Diaphragm Material:** Polyurethane.  
**Operating Voltage:** AC/DC - 30 V or less with resistive load.  
**Weight:** Less than 0.353 oz (10 g).

**MODEL CHART**

Model	Set Point in w.c.	Model	Set Point in w.c.
MDS-0	0.5	MDS-6	6.0
MDS-1	1.0	MDS-8	10.0
MDS-2	1.5	MDS-10	15.0
MDS-3	2.0	MDS-12	30.0
MDS-4	3.0	MDS-14	50.0

Process Tubing Options: See page 455 (Gage Tubing Accessories)

**SERIES MDA**

# MINIATURE ADJUSTABLE PRESSURE SWITCH

Adjustable Set Points from 0.1 to 100 in w.c.

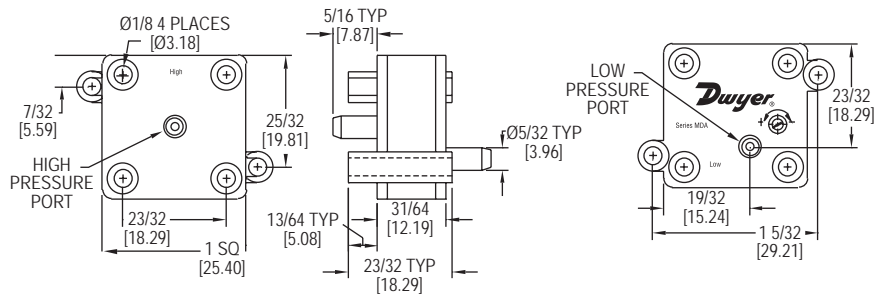

**Series MDA Miniature Adjustable Pressure Switch** is used to sense differential pressure. The switch features field adjustable set point and gold inlay contacts. Air or other compatible fluids can be used on the "high side". The lightweight and compact size make the MDA ideal for any application with space constraints. Applications include industrial, HVAC, pump and motor control, medical, automotive, pools and spas.

**FEATURES/BENEFITS**

- Air or fluid on high side permits multiple uses where both air and liquids exist
- Small and lightweight for applications where space is constrained
- Gold contacts help ensure a clean connection without dirt or oxidation

**APPLICATIONS**

- Industrial
- Medical
- HVAC
- Pump and motor control
- Automotive
- Pools and spas

**SPECIFICATIONS**

**Switch Type:** SPST normally open.  
**Switching Media:** Air or compatible fluids on "high side".  
**Pressure Limits:** MDA-011: 4 psi; MDA-111: 8 psi; MDA-211: 8 psi; MDA-311: 15 psi; MDA-411: 30 psi.  
**Current Rating:** 40 mA resistive for life in excess of 20 million cycles.  
**Temperature Limits:** 40 to 150°F (4 to 66°C).  
**Contacts:** 18K gold inlay.

**Electrical Connections:** Terminals - 0.187" x 0.20: spade (recessed) for use with quick disconnects.  
**Pressure Connections:** Smooth port 5/32" diameter for 1/8" ID tubing.  
**Housing:** Polycarbonate.  
**Diaphragm Material:** Polyurethane.  
**Operating Voltage:** AC/DC - 30 V or less with resistive load.  
**Mounting:** Use #4 screws through mounting lugs or #2 screws through eyelets.  
**Weight:** Less than 0.353 oz (10 g).

**MODEL CHART**

Model	Min. Set Point in w.c. (mbar)	Max. Set Point in w.c. (mbar)
MDA-011	0.1 (0.25)	0.5 (1.25)
MDA-111	0.5 (1.25)	2.0 (4.98)
MDA-211	2.0 (4.98)	15 (37.37)
MDA-311	15 (37.37)	60 (149.3)
MDA-411	60 (149.3)	100 (249.10)

Process Tubing Options: See page 455 (Gage Tubing Accessories)

# DPDT LOW DIFFERENTIAL PRESSURE SWITCHES

## Manual Reset, No Power Required

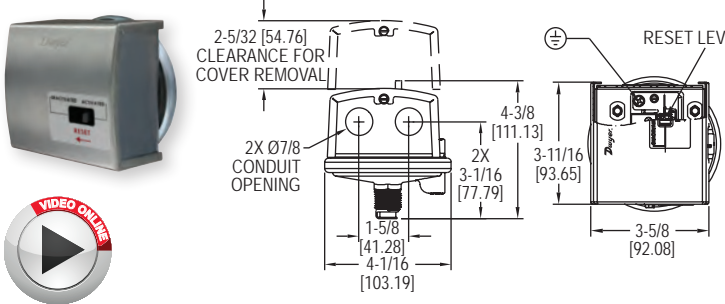

One of our most popular differential pressure switches is now available with a DPDT switch and manual reset. The **Series 1831 DPDT Low Differential Pressure Switches** combine small size with 4% set point repeatability. Absolutely no power is required to operate the DPDT switch. Set point adjustment on the switch is easily accessible for modifying the set point. The Series 1831 DPDT Low Differential Pressure Switches with Manual Reset eliminate common problems associated with typical high duct static cutout installations. Since the 1831 requires absolutely no power to drive its outputs, a separate power loop and its associated additional wiring and conduit is alleviated, reducing material and labor installation costs. Both control contacts of the Series 1831 activate at the same time. The potential of the lead switch shutting down the fan preventing the lag switch from sending an alarming signal to the DDC is no longer a probable system liability. Potential costly maintenance calls are diminished. Unlike typical switches that possess only a single conduit entry for both control loops, the Series 1831 provides two conduit connections simplifying wiring while eliminating additional conduit tees.

### FEATURES/BENEFITS

- No power to operate DPDT switch means no additional wiring or conduit reduces material and installation labor costs
- Easy access for modifying set point simplifies adjustment
- Both control contacts activate at the same time eliminating system issues where lead switch activities prevent the lagging switch from sending a signal

### APPLICATIONS

- High duct static cutout applications
- HVAC

MODEL CHART		
Model	Description	Range (in w.c.)
1831-1-RA-S	Manual reset DPDT, activate on increase	2.5 to 9
1831-2-RA-S	Manual reset DPDT, activate on increase	7.5 to 23

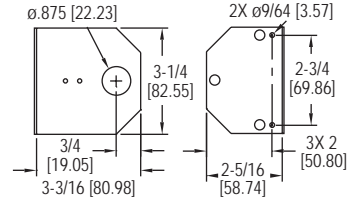

**A-389 mounting bracket**



**Note:** Shown with included mounting bracket. Bracket can rotate and be tightened at any angle.

### SPECIFICATIONS

<b>Service:</b> Air and non-combustible, compatible gases.	<b>Electrical Rating:</b> 4 A @ 125/250 VAC.
<b>Wetted Materials:</b> Consult factory.	<b>Electrical Connections:</b> Screw type terminal block.
<b>Temperature Limits:</b> -30 to 180°F (-34 to 82.2°C).	<b>Process Connections:</b> 1/8" female NPT.
<b>Pressure Limits:</b> 10 psig (68.95 kPa) continuous, 25 psig (172.4 kPa) surge.	<b>Mounting Orientation:</b> Diaphragm in vertical position. Consult factory for other position orientations.
<b>Switch Type:</b> 2 SPDT.	<b>Set Point Adjustment:</b> Screw type inside mounting spud.
<b>Actuation Time Difference:</b> 1 millisecond maximum actuation delay between contacts.	<b>Weight:</b> 1 lb 2 oz (522 g).
<b>Repeatability:</b> ±4% max.	

### ACCESSORIES

Model	Description
A-489	4" straight static pressure tip with flange
A-491	6" straight static pressure tip with flange
A-493	8" straight static pressure tip with flange
A-302F-A	303 SS static pressure tip with mounting flange; for 3/16" ID rubber or plastic tubing; 4" insertion depth; includes mounting screws
A-302F-B	303 SS static pressure tip with mounting flange; for 3/16" rubber or plastic tubing; 6" insertion depth; includes mounting screws
A-302F-C	303 SS static pressure tip with mounting flange; for 3/16" rubber or plastic tubing; 8" insertion depth; includes mounting screws

Process Tubing Options: See page 455 (Gage Tubing Accessories)

## SERIES 1640

# FLOATING CONTACT NULL SWITCH FOR HIGH AND LOW ACTUATION

## Visual Set Point Adjustment, Adjustable Null Zone

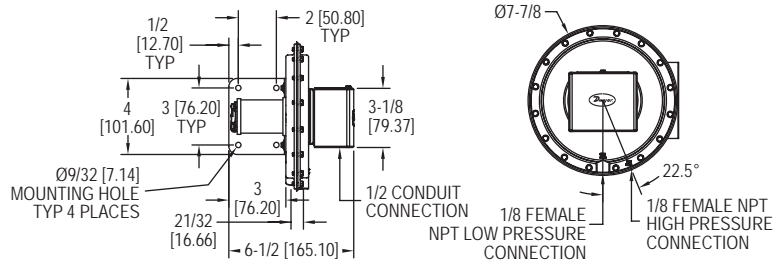
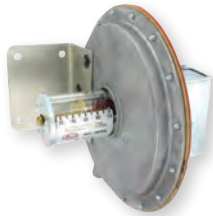

The unique electric switch design in the **Series 1640 Floating Contact Null Switch for High and Low Actuation** is another Dwyer Instrument, Inc. innovation. The Dwyer® Model 1640 Differential Pressure Switch resembles the high precision large diaphragm Series 1630 switches. However, the Model 1640 is equipped with a single pole, double throw floating contact switch (not snap acting) so it functions as a null switch.

As the diaphragm moves in response to pressure changes, it moves the floating contact to cause switching action at two preset points with no switching action between these points. The "high" circuit will be closed when rising pressure differential reaches the preset level. The "low" circuit will be closed when falling pressure differential reaches the preset level.

### FEATURES/BENEFITS

- Floating "null" switch supports applications requiring two set point actions such as open and close damper control
- Visible set point indicator simplifies operation and trouble shooting
- Large diaphragm provides low range accuracy providing precise control

### APPLICATIONS

- Damper positioning
- Duct air control

### SPECIFICATIONS

<b>Service:</b> Air and non-combustible, compatible gases.	<b>1 A @ 110 VAC; 0.5 A @ 220 VAC; 0.5 A @ 24 VDC (de-rate 70-80% for very slow pressure changes).</b>
<b>Wetted Materials:</b> Consult factory.	<b>Electrical Connections:</b> 3 screw type.
<b>Temperature Limits:</b> -30 to 110°F (-34.4 to 43.3°C).	<b>Process Connections:</b> 1/8" female NPT.
<b>Pressure Limits:</b> 10 psig (68.95 kPa) continuous, 25 psig (172.4 kPa) surge.	<b>Mounting Orientation:</b> Diaphragm in vertical position. Consult factory for other position orientations.
<b>Switch Type:</b> SPDT floating contact (not snap action).	<b>Set Point Adjustment:</b> Screw type.
<b>Electrical Rating:</b> Non-inductive — 2.5 A @ 110 VAC; 1.5 A @ 220 VAC; 1 A @ 24 VDC; 0.5 A @ 110 VAC; Inductive —	<b>Weight:</b> 4 lb 13 oz (2.18 kg).
	<b>Agency Approvals:</b> CE.

### MODEL CHART

Model	Ranges in w.c.	Adjustable Null Span	
		Min. Set Point	Max. Set Point
1640-0	.01 to 0.2	.01	.03
1640-1	0.2 to 1.0	.02	.06
1640-2	1.0 to 4.0	.03	.12

Process Tubing Options: See page 455 (Gage Tubing Accessories)





# SINGLE AND DUAL PRESSURE SWITCH

High Reliability, Repetitive Accuracy within  $\pm 1\%$

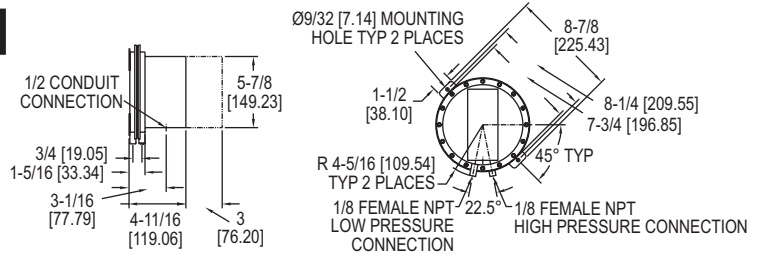
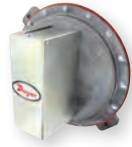

On the **Series 1620 Single and Dual Pressure Switch** our old faithful switch design is still best where highest precision combined with diaphragm sealed leak proof construction and mounting simplicity are required. Model 1626 and 1627 differential pressure switches are identical in design and construction except that Model 1626 has a single electric switch and Model 1627 has dual electric switches. Model 1627 can therefore provide dual control when required. It can be set to open or close two independent electrical circuits, each preset for its own actuation pressure. Both units have diaphragm sealed motion take outs providing maximum protection against leakage.

**FEATURES/BENEFITS**

- Single or dual action switches support consistent designs with similar models, but with the ability to match specific application needs
- Sealed diaphragm provides leak-proof construction for high accuracy and precision control

**APPLICATIONS**

- Damper positioning
- Duct air control

MODEL CHART				
Model	Operating Range in w.c.	Approximate Deadband		Adj. Diff. Between Set Points
		Min. Set Point	Max. Set Point	
1626-1	.15 to 1.5	.10	.20	-
1626-5	.5 to 6.0	.15	.35	-
1626-10	2.0 to 11	.25	.65	-
1626-20	8.0 to 24	.50	1.20	-
1627-1	.15 to 1.5	.10	.20	0.5
1627-5	.5 to 6.0	.15	.35	1.2
1627-10	2.0 to 11	.25	.65	2.3
1627-20	8.0 to 24	.50	1.20	5.0

**SPECIFICATIONS**

**Service:** Air and non-combustible, compatible gases.  
**Wetted Materials:** Consult factory.  
**Temperature Limits:** -30 to 130°F (-34.4 to 54.4°C).  
**Pressure Limits:** Max. 50 in w.c. (12.44 kPa) continuous, 2 psig (13.79 kPa) surge.  
**Switch Type:** 1626 SPDT; 1627, (2) SPDT.  
**Repeatability:**  $\pm 1\%$ .  
**Electrical Rating:** 15 A @ 120-480 VAC, 60 Hz. Resistive, 1/8 HP @ 125 VAC, 1/4 HP @ 250 VAC, 60 Hz.

**Electrical Connections:** 3 screw type, common, normally open and normally closed.  
**Process Connections:** 1/8" female NPT.  
**Mounting Orientation:** Diaphragm in vertical position. Consult factory for other position orientations.  
**Set Point Adjustment:** Screw adjustment.  
**Weight:** Model 1626, 3 lb, 9.8 oz (1.64 kg); Model 1627, 3 lb, 11.8 oz (1.69 kg).  
**Agency Approvals:** CE.

**ACCESSORIES**

Model	Description
A-489	4" straight static pressure tip with flange
A-302F-A	303 SS static pressure tip with mounting flange; for 3/16" ID rubber or plastic tubing; 4" insertion depth; includes mounting screws

**OPTIONS**

To order add suffix:	Description
-MIL	MIL environmental construction

SERIES 1630



# LARGE DIAPHRAGM PRESSURE SWITCH

Visual Set Point Adjustment in 5 Standard Ranges, 0.05 in to 12 in w.c. Repetitive Accuracy within  $\pm 1\%$

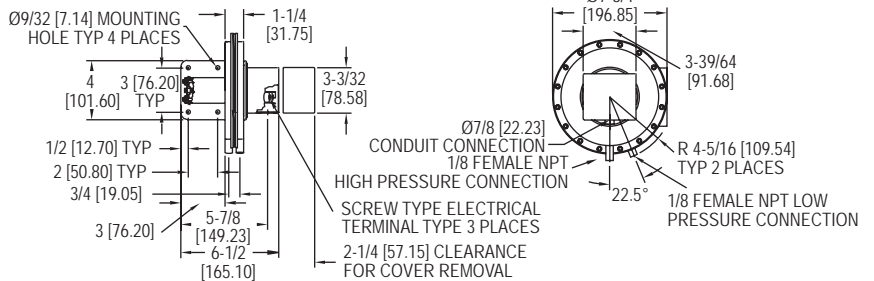

On the **Series 1630 Large Diaphragm Pressure Switch** our highest precision conventional large diaphragm pressure switch provides maximum dependability. In addition, it incorporates a visible set point indicator for maximum convenience. UL and CSA listed, FM approved for general service. Electrical capability of 15 amps handles most small electrical loads. For use only with air or compatible gases.

**FEATURES/BENEFITS**

- Visible set point indicator simplifies operation and trouble shooting
- Large diaphragm provides low range accuracy providing precise control
- Current loads of up to 15 amps supports most small electrical loads supporting a broader range of HVAC and Process applications without the need for additional relays and components

**APPLICATIONS**

- Damper positioning
- Air conditioning
- Duct air control
- Industrial service

MODEL CHART			
Model	Operating Range in w.c.	Approximate Deadband	
		Min. Set Point	Max. Set Point
1638-0	0.05 to 0.25	0.04	0.05
1638-1	0.20 to 1.0	0.04	0.06
1638-2	1.0 to 3.0	0.06	0.08
1638-5	2.0 to 6.0	0.07	0.25
1638-10	3.0 to 12	0.11	0.30

**SPECIFICATIONS**

**Service:** Air and non-combustible, compatible gases.  
**Wetted Materials:** Consult factory.  
**Temperature Limits:** -30 to 110°F (-34.4 to 43.3°C).  
**Pressure Limits:** 10 psig (68.95 kPa) continuous, 25 psig (172.4 kPa) surge.  
**Switch Type:** SPDT.  
**Repeatability:**  $\pm 1\%$ .  
**Electrical Rating:** 15 A @ 120-480 VAC, 60 Hz. Resistive 1/8 HP @ 125 VAC, 1/4 HP @ 250 VAC, 60 Hz.

**Electrical Connections:** 3 screw type, common, normally open and normally closed.  
**Process Connections:** 1/8" female NPT.  
**Mounting Orientation:** Diaphragm in vertical position. Consult factory for other position orientations.  
**Set Point Adjustment:** Screw type with enclosed scale.  
**Weight:** 3 lb 3 oz (1.50 kg).  
**Agency Approvals:** CSA, FM, UL.

**ACCESSORIES**

Model	Description
A-489	4" straight static pressure tip with flange
A-302F-A	303 SS static pressure tip with mounting flange; for 3/16" ID rubber or plastic tubing; 4" insertion depth; includes mounting screws

**OPTIONS**

**MIL Environmental Construction**  
 Unlisted Model 1635 can be furnished with a special sealed snap switch for protection against high humidity, fungus and/or military applications. Similar to Model 1638 except deadband is slightly greater and some lower setpoints may not be available.  
**Note:** To order, specify Model 1635-(Range No.)-MIL and required set point.

Process Tubing Options: See page 455 (Gage Tubing Accessories)



SERIES 1996



# GAS PRESSURE SWITCH

Compact, Low Cost, 1.4 to 20 in w.c. Range

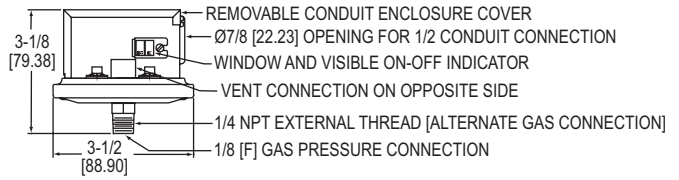
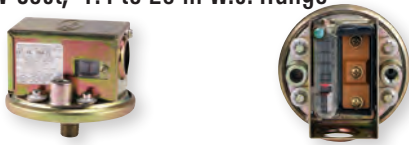

Reliable and convenient, the **Series 1996 Gas Pressure Switch** serves as a compact, low cost switch for gas fired furnaces and equipment. Pressure ranges for both models are ideal for high or low gas pressure interlock. Visible set point and on-off indicators add convenience in servicing. Use either NO or NC contacts on SPDT switch. Bottom connection has both 1/8" female and 1/4" male threads for pipe nipple or coupling. Top connection vents diaphragm chamber to outside or to furnace combustion chamber. Mount switch with diaphragm in a horizontal position and gas pressure connection at bottom. Used with natural, manufactured or LP gas. **●●**

**FEATURES/BENEFITS**

- Visible set point and on-off indicator simplifies operation and trouble shooting
- Compact size and low cost make it ideal for gas fired or gas equipment OEM applications

**APPLICATIONS**

- Gas furnaces
- Natural, manufactured or LP gas applications

**MODEL CHART**

Model	Range (in w.c.)	Model	Range (in w.c.)
1996-5	1.4 to 5.5	1996-20	4-20

**SPECIFICATIONS**

**Service:** Air, natural & manufactured gas, LP gas.  
**Wetted Materials:** Consult factory.  
**Temperature Limits:** 32 to 110°F (0 to 43.3°C). -30 to 110°F (-34.4 to 43.3°C) for dry gas or dry air.  
**Pressure Limits:** 45 in w.c. (11.2 kPa) continuous; 10 psig (68.95 kPa) surge.  
**Switch Type:** SPDT.  
**Electrical Rating:** 15A @ 120-480 VAC, 60 Hz. Resistive 1/8 H.P. @ 125 VAC, 1/4 H.P. @ 250 VAC 60 Hz.  
**Electrical Connections:** 3 screw type, common, normally open, normally closed.  
**Process Connections:** 1/8" female NPT or 1/4" male NPT.  
**Vent Connection:** 1/8" female NPT.  
**Mounting Orientation:** Diaphragm in horizontal position. Consult factory for other position orientations.  
**Set Point Adjustment:** Screw type with visible indicator, inside conduit enclosure.  
**Weight:** 1 lb 2.3 oz (349 g).  
**Agency Approvals:** CE, CSA, FM, UL.

● Explosion-Proof Alternative: See page 55 (Series 1950)

● Explosion-Proof Alternative: See page 55 (Series 1950G)

Process Tubing Options: See page 455 (Gage Tubing Accessories)



SERIES PG | MERCROID® BY DWYER

# GAS PRESSURE/DIFFERENTIAL PRESSURE SWITCHES

External Adjustment, Visible Dial, Hermetically Sealed Snap or Mercury Switch

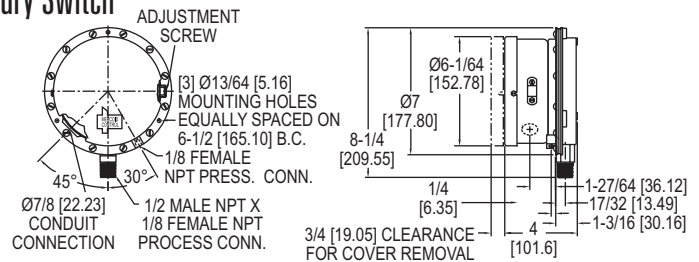

The **Series PG Gas Pressure/Differential Pressure Switch** has a large sensitive diaphragm and a reliable time proven mechanical design. For use with air and other compatible gases, they feature excellent ±1% of full-scale repeatability, clear easy-to-read scale and convenient external set point adjustment.

Application flexibility is assured by a large variety of switching options including SPST, SPDT, DPST and DPDT; opening or closing on increasing pressure, vacuum or differential. PR and PRL models add manual reset operation on increasing or decreasing pressure. Mercury switches or hermetically sealed snap switches are available where high humidity would be a problem. If vibration or other factors preclude the use of mercury, snap switches can be provided. Standard housing is NEMA 1. Optional enclosures can be supplied for weather resistant and explosion-proof requirements.

**FEATURES/BENEFITS**

- Clear easy-to-read scale and external set point adjustment simplifies operation and trouble shooting
- Large diaphragm provides accuracy for precise control
- Multiple switching options meet the design of applications

**APPLICATIONS**

- Natural, manufactured or LP gas applications

**SPECIFICATIONS**

**Wetted Materials:** Fairprene, brass, steel, and aluminum.  
**Temperature Limits:** -10 to 180°F (-23 to 82°C).  
**Pressure Limit:** Single pressure use on high side: Sustained pressure: 15 psig (1.0 bar); Surge limit: 20 psig (1.4 bar). Differential pressure use: Sustained pressure, range P1: 2 psig (.14 bar); Sustained pressure, range P2: 10 psig (0.7 bar).  
**Enclosure Rating:** General purpose. Weatherproof and explosion-proof optional.  
**Repeatability:** ±1% of full range.  
**Switch Type:** SPST mercury switch, SPDT mercury switch, SPDT snap switch, or SPDT hermetically sealed snap switch. Optional DPDT.  
**Electrical Rating:** SPDT mercury: 4A @ 120 VAC/VDC, 2A @ 240 VAC/VDC. SPST mercury: 6A @ 120 VAC/VDC, 3A @ 240 VAC/VDC. SPDT Snap: 15A @ 120 VAC, 8A @ 240 VAC, 0.5A @ 120 VDC, 0.25A @ 240 VDC. SPDT H.S. Silver Snap: 5A @ 125/250 VAC, 30 VDC resistive. SPDT H.S. Gold Snap: 1A @ 125 VAC, 30 VDC resistive.  
**Electrical Connections:** Screw type.  
**Conduit Connection:** 7/8" (22.23 mm) hole for 1/2" (12.7 mm) conduit hub.  
**Process Connection:** 1/2" male NPT and 1/8" female NPT used for single positive pressure or high differential pressure, 1/8" female NPT used for single vacuum or low differential pressure.  
**Mounting Orientation:** Vertical.  
**Set Point Adjustment:** External screw.  
**Weight:** 4.5 lb (2 kg).  
**Deadband:** See model chart.  
**Agency Approvals:** FM, UL for mercury switch models. UL only on snap switch models.

**MODEL CHART**

Model	Range	Max. Deadband	Switch Type	Model	Range	Max. Deadband	Switch Type
PG-153-P1	1-30 in w.c. (.25-7.47 kPa)	1.9 in w.c. (0.47 kPa)	SPDT mercury	PG-7000-153-P1	1-30 in w.c. (.25-7.45 kPa)	4 in w.c. (1.0 kPa)	SPDT snap
PG-153-P2	0.5-5 psid (0.3-.345 bar)	0.4 psid (0.38 bar)	SPDT mercury	PG-7000-153-P2	0.5-5 psid (.03-.345 bar)	.5 psid (.035 bar)	SPDT snap
PG-3-P1	1-30 in w.c. (.25-7.47 kPa)	1.3 in w.c. (0.32 kPa)	SPST mercury*	PG-7000-153HS-P1	1-30 in w.c. (.25-7.47 kPa)	4 in w.c. (1.0 kPa)	SPDT hermetically sealed silver snap
PG-3-P2	0.5-5 psid (.03-.345 bar)	0.3 psid (0.21 kPa)	SPST mercury*	PG-7000-153HG-P1	1-30 in w.c. (.25-7.47 kPa)	4 in w.c. (1.0 kPa)	SPDT hermetically sealed gold snap

\*SPST switches shown are close on increase of pressure.

For open on increase of pressure replace 3 in middle of model number with 2. **Example:** PG-2-P1.

USA: California Proposition 65

⚠ WARNING: Cancer and Reproductive Harm - www.P65Warnings.ca.gov

# EXPLOSION-PROOF DIFFERENTIAL PRESSURE SWITCH

Compact, Low Cost, Explosion-proof and Weatherproof

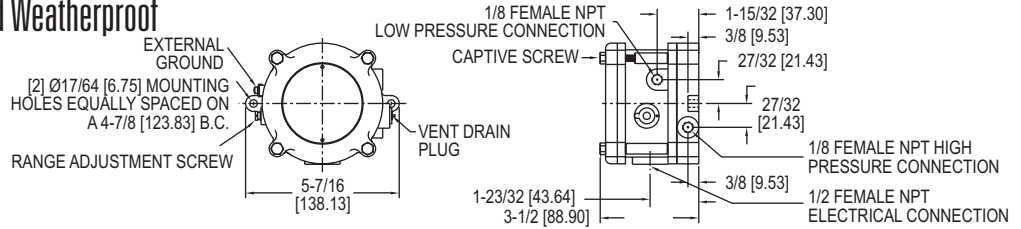

**Series 1950 Explosion-Proof Differential Pressure Switch** combines the best features of the popular Dwyer® Series 1900 Pressure Switch with an integral explosion-proof and weatherproof housing, making it an exceptional value for either application. It is CE, UL and CSA listed, FM approved for use in Class I, Div 1, Groups C and D, Class II Groups E, F, and G and Class III hazardous atmospheres NEMA 7 & 9. Rain tight NEMA 3 (IP54), weatherproof features include a drain plug and O-ring seal in cover. Electrical connections are easily made by removing front cover. For convenience the set point adjustment screw is located on the outside of the housing. Twelve models offer set points from .03 to 20 in w.c. (0.0075 to 5 kPa) and from .5 to 60 psi (0.035 to 3.5 bar). The unit is very light and compact - about half the weight and bulk of other explosion-proof or weatherproof switches with separate enclosures. CAUTION: For use only with air or compatible gases. Applications with hazardous atmospheres and a single positive pressure may require special venting.

**FEATURES/BENEFITS**

- Explosion-proof and weatherproof housing provides device protection for outdoor use or harsh environment operation
- External set point screw provides easy access that simplifies making adjustments without opening or disassembling enclosure
- Easily accessible electrical connection simplifies the installation

**APPLICATIONS**

- HVAC applications
- Process applications
- All-weather applications

**MODEL CHART**

Model	Range, psid	Approximate Deadband		Model*	Range*	Approximate Deadband		Model	Range, in w.c.	Approximate Deadband	
		Min. Set Point	Max. Set Point			Min. Set Point	Max. Set Point			Min. Set Point	Max. Set Point
1950P-2-2F	0.5 to 2	0.3	0.3	1950P-50-2F	15 to 50	1.0	1.5	1950-1-2F	.4 to 1.6	.15	.20
1950P-8-2F	1.5 to 8	1.0	1.0	1950-02-2S	.03 to .10	.025	.05	1950-5-2F	1.4 to 5.5	.30	.40
1950P-15-2F	3 to 15	0.9	0.9	1950-00-2F	.07 to .15	.04	.05	1950-10-2F	3 to 11	.40	.50
1950P-25-2F	4 to 25	0.7	0.7	1950-0-2F	.15 to .50	.10	.15	1950-20-2F	4 to 20	.40	.60

\*P=PSID range models. Other ranges in w.c.

**Caution:** For use only with air or compatible gases. Applications with hazardous atmospheres and a single positive pressure may require special venting.

**SERIES 1950G**

# EXPLOSION-PROOF DIFFERENTIAL PRESSURE SWITCH

Explosion-proof, Weatherproof, Compatible with Natural Gases

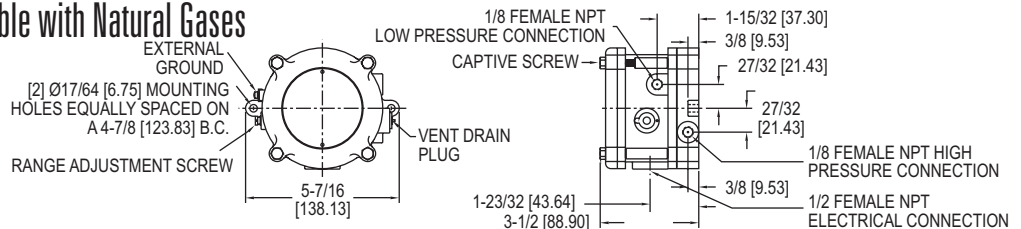

**Series 1950G Explosion-Proof Differential Pressure Switch** combines the best features of the popular Dwyer® Series 1950 Pressure Switch with the benefit of natural gas compatibility. Units are rain-tight for outdoor installations, and are UL listed for use in Class I, Groups A, B, C, & D; Class II, Groups E, F, & G and Class III atmospheres, Directive 2014/34/EU (ATEX) Compliant for CE Ex II 2G Exd IIB+H2 T6, CSA & FM approved for Class I, Div. 1, Groups B, C, D; Class II, Div. 1, Groups E, F, G and Class III atmospheres IECEx Ex d IIB+H2 T6 (-40°C < Ta < +60°C). The 1950G is very compact, about half the weight and bulk of equivalent conventional explosion-proof switches. Easy access to the SPDT relay and power supply terminals is provided by removing the top plate of the aluminum housing. A supply voltage of 24 VDC, 120 or 240 VAC is required. A captive screw allows the cover to swing aside while remaining attached to the unit. Adjustment to the set point of the switch can be made without disassembly of the housing.

**FEATURES/BENEFITS**

- Compatible with natural gas making it suitable for use in those applications
- External set point screw provides easy access that simplifies making adjustments without opening or disassembling enclosure
- Easily accessible electrical connection simplifies the installation

**APPLICATIONS**

- Natural gas applications
- Process applications
- All-weather applications

**SPECIFICATIONS**

**Service:** Air and compatible combustible gases.  
**Wetted Materials:** Contact factory.  
**Temperature Limits:** 0 to 140°F (-17 to 60°C). **Note:** Set point drift may occur with ambient temperature changes.  
**Pressure Limits:** 45 in w.c. (11.2 kPa) continuous; 10 psig (68.95 kPa) surge.  
**Enclosure Rating:** NEMA 3 (IP54), NEMA 7 & 9.  
**Switch Type:** 1 Form C relay (SPDT).  
**Electrical Rating:** 10 A, 120/240 VAC, 28 VDC. Resistive 50 mA, 125 VDC.  
**Power Requirements:** 24 VDC ±10%. 120 or 240 VAC ±10% optional.  
**Electrical Connections:** Internal terminal block.  
**Process Connections:** 1/8" female NPT.  
**Mounting Orientation:** Diaphragm in vertical position. Consult factory for other position orientations.  
**Set Point Adjustment:** Screw type on top of housing.  
**Weight:** 2 lb 15.7 oz (1.35 kg).  
**Agency Approvals:** ATEX, CE, CSA, FM, IECEx, UL.

**MODEL CHART**

UL, CSA, FM Model	ATEX Model	Range in w.c.	Approximate Deadband	
			Min. Set Point	Max. Set Point
1950G-00-B-24-NA	1950G-00-B-24	.07 to .15	.04	.06
1950G-0-B-24-NA	1950G-0-B-24	.15 to .50	.06	.11
1950G-1-B-24-NA	1950G-1-B-24	.4 to 1.6	.11	.29
1950G-5-B-24-NA	1950G-5-B-24	1.4 to 5.5	.4	.9
1950G-10-B-24-NA	1950G-10-B-24	3 to 11	.9	1.8
1950G-20-B-24-NA	1950G-20-B-24	4 to 20	1.2	3.0

240 VAC Models: 1950G-XX-B-240-NA; 120 VAC Models: 1950G-XX-B-120-NA





SERIES H3 | W. E. ANDERSON™ BY DWYER



# EXPLOSION-PROOF DIFFERENTIAL PRESSURE SWITCH

Set points from 10 in w.c. to 200 psid, Rated 1500 psig, Weatherproof

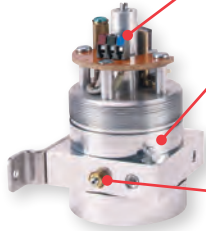

Internal terminal blocks for conductors up to 18 gage are optional

Optional NEMA 3 (IP54) enclosure includes explosion-proof drain; Standard NEMA 4X (IP56) version is without drain

External ground connection standard (internal ground connection also standard, use either one)

Shown without enclosure and cover

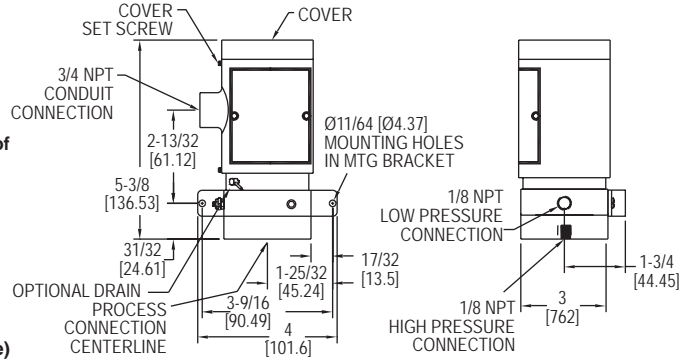

The Series H3 Explosion-Proof Differential Pressure Switch is a heavy duty, industrial unit with a unique new design which provides sensitivity to differential pressures as low as 10 inches of water (254 mm w.c.), yet handles total pressure of 1500 psi (103 bar). Unlike common differential pressure switches that use a piston-type motion transfer, the Series H3 utilizes a rotary motion transfer shaft that prevents a change in total pressure from causing a set point shift. Unit yields deadbands approximately 5% of range, with zero set point shift due to variation in working pressures. Friction is minimized and repeatability increased by allowing range spring to act directly on diaphragm plate. Rolling diaphragm design maintains constant effective area to further reduce friction. Diaphragm is allowed to "seat", allowing application of full rated pressure, up to 1500 psi (103 bar), on either high or low pressure port, without damage. Special over-travel feature prevents overtightening of range adjust screw. Choose optional 316 SS chamber for water and water-based fluids or harsher applications.

**FEATURES/BENEFITS**

- Rotary motion design prevents set point shifts
- Explosion-proof housing for use in applications where protection of process and personnel is needed
- Option for use with water and water-based solution makes this a versatile switch

**APPLICATIONS**

- Water flow proving with an orifice plate
- Differential pressure across chiller
- Liquid filter status

**SPECIFICATIONS**

**Wetted Materials:** See pressure chamber and diaphragm material in model chart.  
**Temperature Limit:** -4 to 220°F (-20 to 104°C), ATEX: -20 to 90°C (-4 to 194°F).  
**Pressure Limit:** 1500 psig (103 bar).  
**Enclosure Rating:** Standard meets NEMA 4X (IP56), drain option meets NEMA 3 (IP54). For hazardous use see the hazardous location ratings chart.  
**Switch Type:** SPDT or DPDT snap switch.  
**Electrical Rating:** 5 A @ 125/250 VAC, 30 VDC.  
**Electrical Connections:** See model chart.  
**Conduit Connection:** 3/4" female NPT.  
**Process Connection:** 1/8" female NPT.  
**Mounting Orientation:** Vertical.  
**Set Point Adjustment:** Internal screw.  
**Weight:** 4 lb 2 oz (2 kg).  
**Deadband:** Approximately 5% of range.  
**Agency Approvals:** ATEX, CE, CSA, UL see ratings chart.

MODEL CHART							
Example	H3	S	-2	S	C	-MV	H3S-2SC-MV
Series	H3						Explosion-proof differential pressure switch
Pressure Chamber & Diaphragm Material (Wetted)	A	S					Aluminum chamber with Nitrile diaphragm 316 SS chamber with Fluoroelastomer diaphragm
Adjustable Operating Range			1 2 3 4				10-180 in. w.c. (2.48-44.78 kPa) 0.5-15 psid (.03-1 bar) 5-70 psid (.34-4.8 bar) 10-200 psid (.7-13.8 bar)
Circuit (Switch) Options				S D			SPDT snap action switch rated 5 A @ 125/250 VAC, 30 VDC DPDT snap action switch rated 5 A @ 125/250 VAC, 30 VDC
Electrical Connection					L T C		18 AWG x 18 inch lead wires UL, CSA approved internal terminal block ATEX approved internal terminal block
Options						Drain MV VIT	Enclosure with drain - allows condensate to be drained from inside (meets NEMA 3 instead of 4X) Gold contacts on snap switch for dry circuits rated 1 A @ 125 VAC, 1A resistive or 0.5 A inductive @ 30 VDC Fluoroelastomer diaphragm option where not standard

HAZARDOUS LOCATION RATINGS			
Model	UL	CSA	Directive 2014/34/EU ATEX Compliant
H3 _ _ _ C	-	-	CE 0344 Ex II 2 G EEx d IIB -20°C ≤ T amb ≤ 75°C T6 EC-Type Certificate No. KEMA 03ATEX 2584
H3 _ _ _ L	Cl. I, Gr.B, C & D Cl. II, Gr.E, F & G	Cl. I, Gr.B, C & D Cl. II, Gr.E, F & G	-
H3 _ _ _ T	Cl. I, Gr.B, C & D Cl. II, Gr.E, F & G	Cl. I, Gr.B, C & D Cl. II, Gr.E, F & G	-
H3 _ _ _ C-DRAIN	-	-	CE 0344 Ex II 2 G EEx d IIB -20°C ≤ T amb ≤ 75°C T6 EC-Type Certificate No. KEMA 03ATEX 2584
H3 _ _ _ L-DRAIN	Cl. I, Gr.B, C & D Cl. II, Gr.E, F & G	-	-

ACCESSORIES	
Model	Description
A-610	Pipe mounting kit for 1-1/4 to 2" pipe



# WET/WET DIFFERENTIAL PRESSURE SWITCH

## NEMA 4X Enclosure, Low Differential Set Points

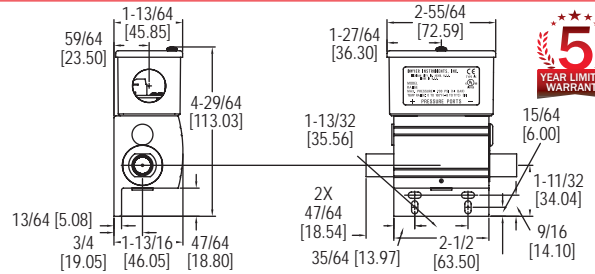

The **Series DX Wet/Wet Differential Pressure Switch** makes a contact output based on the differential between two pressure sources. Wetted materials of brass and fluoroelastomer are suitable for use with most gases and water based solutions. The switch can be used for low differential pressure indication with set point on a decrease of pressure as low as 1 psid (0.07 bar). Differential set point ranges are available from 2.5 to 75 psid (0.17 to 5.17 bar) on increasing differential pressure and 1.0 to 67 psid (0.07 to 4.62 bar) on decreasing differential pressure. Unit features a high static pressure rating of 200 psig (13.8 bar). Weatherproof, UL type 4X, enclosure for dust laden, outdoor, or wash-down installation environments. Externally adjustable set point, integral mounting flange and a removable electrical terminal block for quick and easy installation.

### FEATURES/BENEFITS

- Differential pressure switch that is suitable for most gas and water-based applications allows multiple uses in the most sophisticated designs
- Weatherproof housing provides protection in the harsh, wet or dirty environments ensuring switch's long-service life
- Removable terminal block reduces installation time

### APPLICATIONS

- Indicating filter condition
- Proof of flow indicator monitoring
- Proving flow through a pump
- Proving flow through a chiller
- Proving flow through a heat pump or AC unit

OPTIONS	
To order add suffix:	Description
-PRESET	Preset unit
Example: DXW-11-153-1-PRESET	

USA: California Proposition 65

⚠WARNING: Cancer and Reproductive Harm - www.P65Warnings.ca.gov

### SPECIFICATIONS

**Service:** Compatible gases and liquids.  
**Wetted Materials:** Connection: Brass; Diaphragm: Fluoroelastomer.  
**Temperature Limits:** 30 to 140°F (-1 to 60°C).  
**Pressure Limits:** 200 psig (13.8 bar). Continuous single side only pressure should not exceed 1.25 x full differential range.  
**Enclosure Rating:** Weatherproof UL type 4X (IP65).  
**Repeatability:** ±2% of full range.  
**Switch Type:** SPDT snap switch.  
**Electrical Rating:** 5 A @ 125/250 VAC (~), 5 A res. @ 30 VDC (---).  
**Electrical Connection:** Removable terminal block.

**Conduit Connection:** 0.871" diameter hole for 1/2" conduit fitting.  
**Process Connection:** 1/4" NPT female.  
**Mounting Orientation:** Ports on horizontal plane, ±10°.  
**Set Point Adjustment:** External screw.  
**Housing Materials:** Body: Aluminum; Housing: Polycarbonate; Cover: 300 SS.  
**Vibration and Shock:** Set point repeats after 2.5 Gs, 5 to 500 Hz. Set point repeats after a 15 Gs, 10 millisecond duration.  
**Humidity Limit:** 80% (non-condensing).  
**Pollution Degree:** 2.  
**Environment:** Intended for indoor and outdoor use.  
**Weight:** 1 lb 3 oz (0.54 kg).  
**Agency Approvals:** CE, cULus.

### MODEL CHART

Model	Adjustable Differential Range (on increase) [psid (bar)]	Fixed Deadband [psid (bar)]	
		Low Set Point	High Set Point
DXW-11-153-1	2.5 to 10 (0.17 to 0.69)	1.5 (0.10)	2.5 (0.17)
DXW-11-153-2	10 to 25 (0.69 to 1.72)	2.5 (0.17)	3.5 (0.24)
DXW-11-153-3	25 to 50 (1.72 to 3.45)	3.5 (0.24)	6.0 (0.41)
DXW-11-153-4	50 to 75 (3.46 to 5.17)	6.0 (0.41)	8.0 (0.55)

Note: Set points on decrease will be the range minus the deadband.

## SERIES DP | MERCOID® BY DWYER

# DOUBLE BELLOWS DIFFERENTIAL PRESSURE SWITCH

## Visible Set Points, Adjustable or Fixed Deadband, High Pressure Ranges

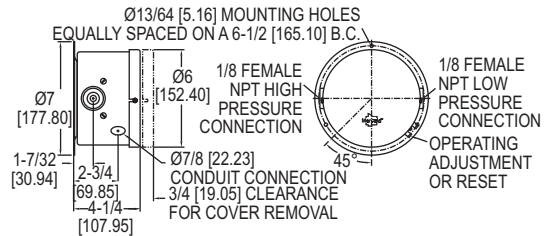
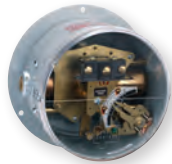

Two opposing bellows combine maximum sensitivity and vibration resistance at a moderate cost in the **Series DP Double Bellows Differential Pressure Switch**. Both set and reset points are easily adjustable through non-interactive, externally accessible controls. Visible set point indicators simplify changes. SPDT snap action switch, 316 stainless steel or brass bellows, flanged steel housing. Rated pressures to 600 psig.

### FEATURES/BENEFITS

- Bellows switch design provides sensitivity to pressure changes but resists vibration preventing out of range switching
- External access to set and reset controls makes for easy adjustments
- Visible set point indicators simplify changes

### APPLICATIONS

- Accurate switch triggers in high pressure applications

### MODEL CHART

Bellows Material	Range, psid (bar)	Max. Press, psig (bar)	Adjustable Deadband		Fixed Deadband	
			Min. D.B. psid (bar)	Model	Fixed D.B. psid (bar)	Model
Brass	0-10 (0-0.7)	50 (3.5)	1.5 (.10)	DPA-7033-153-61	0.5 (.03)	DPS-7233-153-61
Brass	0-20 (0-1.4)	100 (6.9)	2.5 (.17)	DPA-7033-153-62	1.0 (.07)	DPS-7233-153-62
Brass	0-30 (0-2.1)	300 (20.7)	6.0 (.41)	DPA-7033-153-64	1.5 (.10)	DPS-7233-153-64
316 SS	0-20 (0-1.4)	100 (6.9)	3.0 (.21)	DPA-7043-153-62E	1.5 (.10)	DPS-7243-153-62E
316 SS	0-30 (0-2.1)	300 (20.7)	6.0 (.41)	DPA-7043-153-64E	2.0 (.14)	DPS-7243-153-64E
316 SS	0-80 (0-5.5)	600 (41.4)	20 (1.4)	DPA-7043-153-65E	6.0 (.41)	DPS-7243-153-65E

USA: California Proposition 65

⚠WARNING: Cancer and Reproductive Harm - www.P65Warnings.ca.gov

### SPECIFICATIONS

**Wetted Materials:** Brass on ranges 61, 62, 63 or 316 SS on ranges 62E, 64E, 65E.  
**Temperature Limits:** -10 to 180°F (-23 to 82°C).  
**Pressure Limit:** Maximum pressure of the operating range.  
**Enclosure Rating:** General purpose. Weatherproof or explosion-proof optional.  
**Switch Type:** Snap switch. (Contact factory for mercury switch).  
**Electrical Rating:** See model chart.  
**Electrical Connection:** Screw terminal.

**Conduit Connection:** General purpose: 1/2" hole for conduit hub; Weatherproof: 1/2" conduit hub; Explosion-proof: 3/4" female NPT.  
**Process Connection:** General purpose and weatherproof: 1/8" female NPT, explosion-proof: 1/4" male NPT.  
**Mounting Orientation:** Vertical.  
**Set Point Adjustment:** Thumbscrew.  
**Weight:** General purpose: 5 lb (2.3 kg), weatherproof: 7 lb (3 kg), explosion-proof: 25 lb (11 kg).  
**Deadband:** See model chart.  
**Agency Approvals:** CE, cULus.

### OPTIONS

To order add suffix:	Description
W	Weatherproof enclosure
Example: DPAW-7033-153-61	
E	Explosion-proof enclosure
Example: DP AE-7033-153-61	

# DIFFERENTIAL PRESSURE TRANSMITTERS $\pm 0.25$ , $\pm 1$ , OR $\pm 2\%$ ACCURACY

One-Touch® Digital Push-Button Calibration Technology

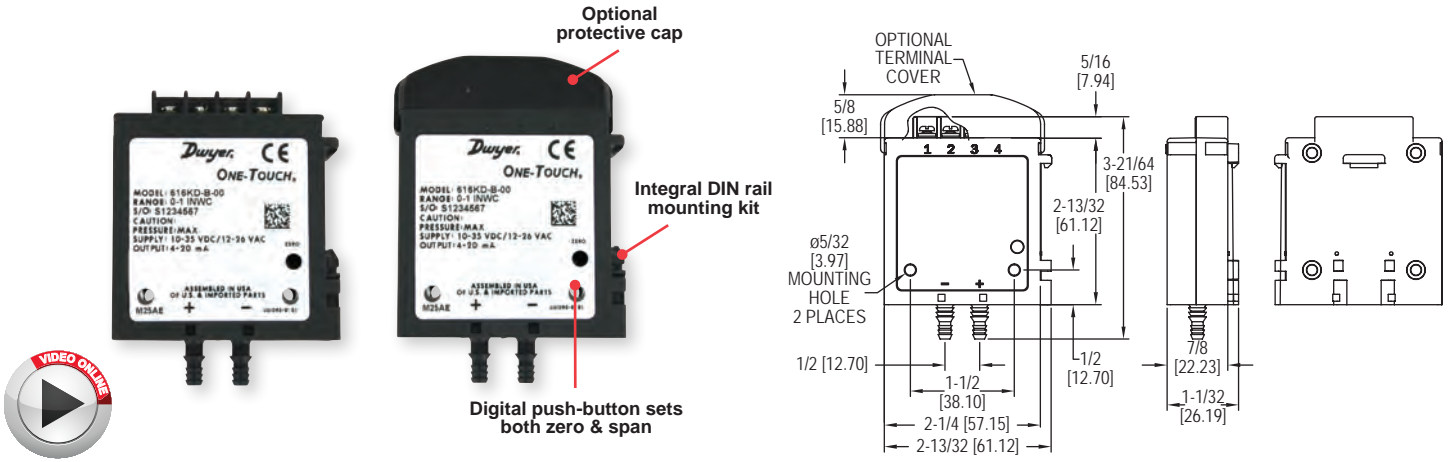

The Series 616KD Differential Pressure Transmitters  $\pm 0.25$ ,  $\pm 1$ , or  $\pm 2\%$  Accuracy with One-Touch® Digital Push-Button Calibration Technology are designed for simplicity, making them the ideal choice for installers and maintenance professionals. These instruments not only alleviate cumbersome turn pots typically found in most transmitters, but eliminate entirely the need to span the instruments during calibration. With a single digital push-button, both ZERO AND SPAN are calibrated properly, nothing else is required. No additional reference pressure sources or separate calibration devices are necessary.

**FEATURES AND BENEFITS**

- Simple calibration push-button sets back zero and span, saving time installing and over the service life
- Cost effective and compact device suitable for OEM applications where space, simplicity, and value are key
- Ranges and accuracy selection cover a wide range of applications minimizing components and determining standardizing on design
- Optional 1/8" NPT process connection allows for use with metal barbed fittings or compression fittings for use with metal tubing
- Optional plenum rated units meeting UL Standard 2043 are available

**APPLICATIONS**

- Air handlers
- Variable air volume
- Duct pressure
- Filter monitoring

**MODEL CHART**

Example	616KD	-A	-12	-AT	616KD-A-12-AT
<b>Series</b>	616KD				Differential pressure transmitter
<b>Accuracy</b>		A B			0.25% full-scale accuracy 1.0% full-scale accuracy 2.0% full-scale accuracy
<b>Range</b>			00 01 02 03 04 05 06 07 08 10 11 12 13 14 15 50 51 57 52 53 54 55 56 58		0 to 1 in w.c. 0 to 2 in w.c. 0 to 3 in w.c. 0 to 5 in w.c. 0 to 10 in w.c. 0 to 15 in w.c. 0 to 20 in w.c. 0 to 25 in w.c. 0 to 40 in w.c. 0 to 250 Pa 0 to 500 Pa 0 to 750 Pa 0 to 1250 Pa 0 to 2500 Pa 0 to 5000 Pa 0 to $\pm 1$ in w.c. 0 to $\pm 2$ in w.c. 0 to $\pm 3$ in w.c. 0 to $\pm 5$ in w.c. 0 to $\pm 10$ in w.c. 0 to $\pm 250$ Pa 0 to $\pm 500$ Pa 0 to $\pm 750$ Pa 0 to $\pm 1250$ Pa
<b>Options</b>				AT FC NIST TC V N PR	Aluminum tag Factory calibration NIST certification Terminal cover Voltage output 0-5, 1-5, 0-10, 2-10 VDC (field selectable) 1/8" female NPT Plenum rated

**Note:** 0.25% FS accuracy is not available in the following ranges 00, 01, 10, 11, 50, 51, 54, 55

**SPECIFICATIONS**

**Service:** Air and non-combustible, compatible gases.  
**Wetted Materials:** Consult factory.  
**Accuracy:** 616KD-A:  $\pm 0.25\%$  FS; 616KD-B:  $\pm 1\%$  FS, 616KD:  $\pm 2\%$  FS.  
**Stability:**  $\pm 1\%$  FS/year.  
**Temperature Limits:** 0 to 140°F (-17.8 to 60°C).  
**Compensated Temperature Range:** 20 to 122°F (-6.67 to 50°C).  
**Pressure Limits:** 2 psig (ranges 5 in w.c. or lower); 5 psig (ranges 10 to 40 in w.c.).  
**Thermal Effect:** 616KD-A:  $\pm 0.02\%$  FS/°F; 616KD-B:  $\pm 0.04\%$  FS/°F; 616KD:  $\pm 0.06\%$  FS/°F, includes zero and span.  
**Power Requirements:** 4-20 mA output: 10-35 VDC (2 wire) or 12-26 VAC (4 wire); 5V output: 10-35 VDC (3 wire) or 12-26 VAC (4 wire); 10V output: 13-35 VDC (3 wire) or 12-26 VAC (4 wire) for 616KD A and B. 16-36 VDC (2 or 3 wire): 20-28 VAC (3 wire) for 616KD.  
**Output Signal:** 4-20 mA or option with field selectable 0-10, 0-5, 2-10, 1-5 V.  
**Zero and Span Adjustments:** Push button.  
**Loop Resistance:** 4-20 mA output (DC): 0 to 1250  $\Omega$  max. Rmax = 50 (VpsDC -10)  $\Omega$ ; 4-20 mA output (AC): 0 to 1200  $\Omega$  max. Rmax = 50 (1.4 VpsAC -12)  $\Omega$ ; Voltage output: 5K  $\Omega$  minimum.  
**Current Consumption:** 24 mA max for 616KD A and B. 21 mA max for 616KD.  
**Electrical Connections:** Screw-type terminal block.  
**Process Connections:** Barbed, dual size to fit 1/8" & 3/16" (3 mm and 5 mm) ID rubber or vinyl tubing.  
**Enclosure Rating:** NEMA 1 (IP20).  
**Mounting Orientation:** Vertical with pressure connections pointing down.  
**Weight:** 1.8 oz (51 g).  
**Agency Approvals:** CE, optional plenum rated units meet UL Standard 2043.

**ACCESSORIES**

Model	Description
A-360	Aluminum DIN rail 1 m
A-618	Protective terminal cap



Optional NPT connection block

# DIFFERENTIAL PRESSURE TRANSMITTERS - LOW RANGES

High Accuracy, Ranges Down to 0.1 in w.c. (25 Pa)

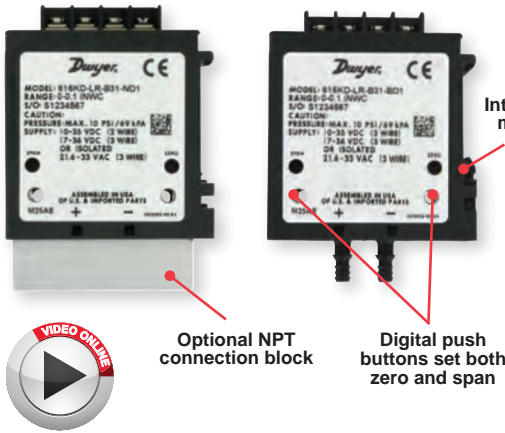

Optional NPT connection block

Digital push buttons set both zero and span

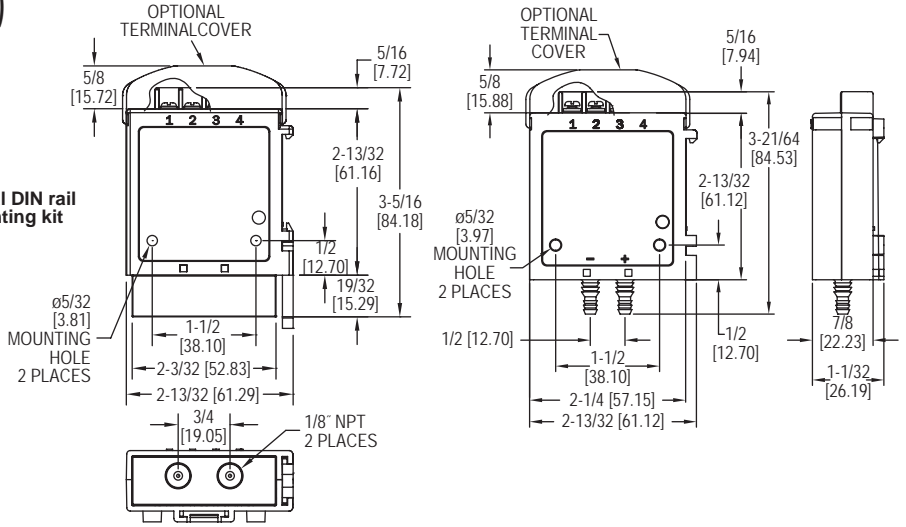

Integral DIN rail mounting kit

The Series 616KD-LR Differential Pressure Transmitters - Low Ranges are designed for simplicity, making it the ideal choice for installers and maintenance professionals. These low range instruments not only alleviate cumbersome turn pots typically found in most transmitters, but eliminate entirely the need to span the instruments during calibration. With single digital push-button, both ZERO AND SPAN are calibrated properly, nothing else is required. No additional reference pressure sources or separate calibration devices are necessary.

**FEATURES/BENEFITS**

- Wide selection of low ranges and accuracy cover numerous applications minimizing components and standardizing on design
- Simple calibration push-buttons to set zero and span, saving time installing and maintaining over the service life
- Cost effective and compact device suitable for OEM applications where space, simplicity, and value are key
- Simultaneous current and voltage outputs
- Optional 1/8" NPT process connection allows for use with metal barbed fittings or compression fittings for use with metal tubing
- Optional plenum rated units meeting UL Standard 2043 are available

**APPLICATIONS**

- Air handlers
- Variable air volume
- Duct pressure
- Filter monitoring

**SPECIFICATIONS**

**Service:** Air and non-combustible, compatible gases.  
**Wetted Materials:** Consult factory.  
**Accuracy:** ±0.25% FS for ±0.4" (100 Pa) and ±0.5" (125 Pa), ±0.5% FS for ±0.25" (60 Pa), and ±1% FS for ±0.1" (25 Pa).  
**Stability:** ±1% / year FSO.  
**Temperature Limits:** 0 to 140°F (-17.8 to 60°C).  
**Pressure Limits:** 1 psi max., operation; 10 psi burst.  
**Power Requirements:** 10-35 VDC (2 wire), 17-36 VDC or isolated 21.6-33 VAC (3 wire).  
**Output Signal:** 4-20 mA (2-wire), 0-5 VDC, 0-10 VDC (3-wire).  
**Response Time:** 2.5 Hz sample rate.

**Zero and Span Adjustments:** Push buttons.  
**Loop Resistance:** Current Output: 0 to 1250Ω max; Voltage Output: Min. load resistance 1kΩ.  
**Current Consumption:** 40 mA max.  
**Electrical Connections:** Screw-type terminal block.  
**Process Connections:** Barbed, dual size to fit 1/8" & 3/16" (3 mm & 5 mm) ID rubber or vinyl tubing, or 1/8" NPT.  
**Enclosure Rating:** NEMA1 (IP20).  
**Mounting Orientation:** Vertical with pressure connections pointing down.  
**Weight:** 1.8 oz (51 g).  
**Agency Approvals:** CE, optional plenum rated units meet UL Standard 2043.

MODEL CHART							
Example	616KD-LR	-A	34	-B	D1	-FC	616KD-LR-A34-BD1-FC
Series	616KD-LR						Differential pressure transmitter
Accuracy		A B D					0.25% FS accuracy 1.0% FS accuracy 0.5% FS accuracy
Range			31 32 34 35 41 42 44 45 61 62 64 65 71 72 74 75				0 to 0.1 in w.c. ① 0 to 0.25 in w.c. ② 0 to 0.4 in w.c. 0 to 0.5 in w.c. 0 to ±0.1 in w.c. ① 0 to ±0.25 in w.c. ② 0 to ±0.4 in w.c. 0 to ±0.5 in w.c. 25 Pa ① 60 Pa ② 100 Pa 125 Pa 0 to ±25 Pa ① 0 to ±60 Pa ② 0 to ±100 Pa 0 to ±125 Pa
Process Connection				B N			Plastic barb 1/8" female NPT with front push-button
Output					D1 D2 D3 D4		4-20 mA and 0-10 V 4-20 mA and 0-5 V 4-20 mA and 2-10 V 4-20 mA and 1-5 V
Options						AT COC FC NIST TC PR	Aluminum tag Certificate of Conformance Factory calibration certificate NIST traceable calibration certificate Terminal cover Plenum rated

ACCESSORIES	
Model	Description
A-360	Aluminum DIN rail 1 m
A-618	Protective terminal cap



A-618 installed on unit

①B accuracy only. ②B and D accuracies only.



# COMPACT DIFFERENTIAL PRESSURE TRANSMITTERS

Ranges from 0.1 to 100 in w.c., Overpressure Protection to 15 psig, ±0.8% Accuracy



668B



668D

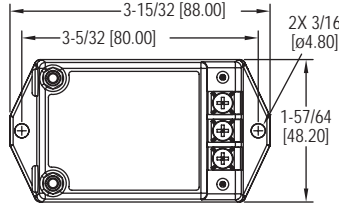

668B

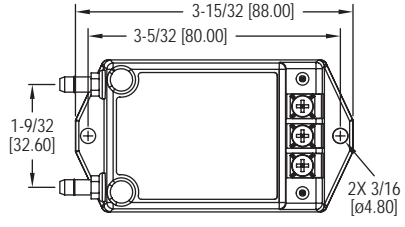
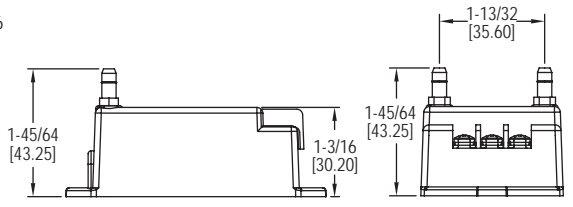

668D

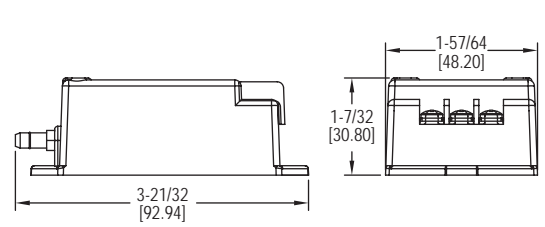

Our low cost **Series 668B/D Compact Differential Pressure Transmitters** are capable of sensing differential gage pressure with ±0.8% FS accuracy, and converts this pressure difference to a proportional high level analog output for both unidirectional and bi-directional pressure ranges. These transmitters can withstand up to 15 psig overpressure with no damage to the unit. The compact, lightweight design makes installation simple and easy. Units are protected against incorrect wiring, and include a protective terminal cover.

**FEATURES/BENEFITS**

- Protection from 15 psi overpressure & incorrect wiring
- High accuracy at low pressure ranges
- Two package selections allows easy device mounting to best fit application pressure connections

**APPLICATIONS**

- HVAC and VAV control
- Clean rooms and isolation rooms
- Duct static pressure measurement

MODEL CHART			
Example	668	B	-08 -1 668B-08-1
Series	668		Compact differential pressure transmitter
Connection		B D	Front Bottom
Unidirectional Pressure Ranges		01	0 to 0.1 in w.c.
		21	0 to 0.2 in w.c.
		02	0 to 0.25 in w.c.
		22	0 to 0.4 in w.c.
		03	0 to 0.5 in w.c.
		04	0 to 1 in w.c.
		05	0 to 2.5 in w.c.
		06	0 to 5 in w.c.
		07	0 to 10 in w.c.
		08	0 to 25 in w.c.
		09	0 to 50 in w.c.
		10	0 to 100 in w.c.
		12	0 to ±0.1 in w.c.
		13	0 to ±0.25 in w.c.
		14	0 to ±0.5 in w.c.
		15	0 to ±1 in w.c.
		16	0 to ±2.5 in w.c.
		17	0 to ±5 in w.c.
		18	0 to ±10 in w.c.
	19	0 to ±25 in w.c.	
Output		1	4 to 20 mA
		2	0 to 10 VDC
		3	0 to 5 VDC

**SPECIFICATIONS**

**Service:** Air and non-conductive gases.  
**Accuracy:** ±0.8% FS.  
**Temperature Limits:** Operating: 0 to 170°F (-18 to 77°C); Storage: -40 to 185°F (-40 to 85°C).  
**Pressure Limits:** 15 psig (1.0 bar).  
**Thermal Effects:** ±0.03% FS/°F (±0.054% FS/°C).  
**Compensated Range:** From 40 to 170°F (4.4 to 77°C).  
**Power Requirements:** 12-32 VDC.  
**Output Signals:** 4-20 mA (2-wire), 0-10 VDC (3-wire), or 0-5 VDC (3-wire).  
**Zero Adjustment:** Accessible under the small terminal cover.  
**Electrical Connection:** Terminal strip.  
**Process Connection:** 3/16" OD barbed brass for 1/8" ID push-on tubing.  
**Enclosure:** Stainless steel and PC+ABS alloy, UL 94 V-0 rated.  
**Weight:** 4.0 oz (113 g).

**ACCESSORIES**

Model	Description
A-TC	Replacement protective terminal cover

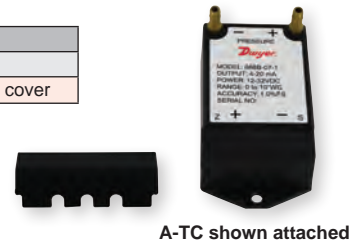

**OPTIONS**

Use order code:	Description
NISTCAL-PT1	NIST traceable calibration certificate

USA: California Proposition 65  
 ⚠ WARNING: Cancer and Reproductive Harm - www.P65Warnings.ca.gov



# DIN RAIL DIFFERENTIAL PRESSURE TRANSMITTER

Mounts on 35 mm DIN Rail,  $\pm 0.25\%$  Full-Scale Accuracy

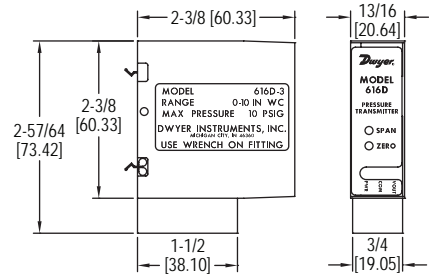

The Series 616D Din Rail Differential Pressure Transmitter senses the pressure of air and compatible gases and sends a standard 4-20 mA or 0-10 VDC output signal. The 616D enclosure is specifically designed to mount on a 35 mm DIN rail in a panel. This mounting style allows for several units to be mounted closely together reducing required space. The span and zero controls are for use when checking calibration. They are not intended for re-ranging. Versatile circuit design enables operation in 2-wire current loops.

### FEATURES/BENEFITS

- Simple calibration push-buttons to set zero and span
- Cost effective and compact device suitable for OEM applications where space, simplicity, and value are key

### APPLICATIONS

- Air handlers
- Variable air volume
- Duct pressure
- Filter monitoring

MODEL CHART		
Model	Range	Max. Pressure
616D-2	0 to 6 in w.c.	10 psig
616D-3	0 to 10 in w.c.	10 psig
616D-4	0 to 20 in w.c.	20 psig
616D-5	0 to 40 in w.c.	20 psig
616D-6	0 to 100 in w.c.	15 psig
616D-7	0 to 200 in w.c.	45 psig
616D-8	0 to 10 psid	45 psig

### SPECIFICATIONS

**Service:** Air and non-combustible, compatible gases.  
**Wetted Materials:** Consult factory.  
**Accuracy:**  $\pm 0.25\%$  FS @ 77°F (25°C).  
**Thermal Effect:**  $\pm 0.02$  FS/°F ( $\pm 0.036\%$  FS/°C).  
**Stability:**  $\pm 1\%$  FS/yr.  
**Temperature Limits:** 14 to 185°F (-10 to 85°C).  
**Pressure Limits:** See chart.  
**Power Requirements:** 10-35 VDC (2-wire); 17-36 VDC, or isolated 21.6-33 VAC (3-wire).  
**Output Signal:** 4-20 mA (2-wire); 0-10 VDC (3-wire).  
**Zero and Span Adjustments:** Push-buttons.  
**Loop Resistance:** Current output: 0 to 1250  $\Omega$  max; Voltage output: Load resistance 1 k $\Omega$  min.  
**Current Consumption:** 40 mA max.  
**Electrical Connections:** Screw-type terminal block.  
**Process Connections:** 1/8" female NPT. Accessories included are 2 barbed fittings for 1/8" (3.12 mm) and 3/16" (4.77 mm) ID rubber or vinyl tubing.  
**Mounting Orientation:** Vertical, on a 1.378" (35 mm) DIN rail.  
**Weight:** 4.8 oz (136 g).  
**Agency Approvals:** CE.

### ACCESSORIES

Model	Description
A-360	Aluminum DIN Rail 1 m

## SERIES RSM

# ROOM STATUS MONITOR

For Sensing Low Pressure Using High Accuracy

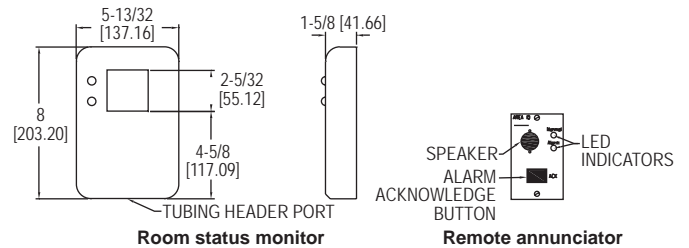

Series RSM Room Status Monitor is designed for critical low differential pressure applications that require stringent pressure monitoring and alarming. The Series RSM can be configured to monitor positive or negative pressure in protected environments and hospital isolation rooms per CDC guidelines. The RSM is a complete system with a graphic user interface which enables access to pressure, security, calibration, and alarm setup. The RSM has a NEMA 1 (IP20) rated fire retardant plastic for indoor applications.

### FEATURES/BENEFITS

- Accurately monitors protective environments for negative or positive pressure ensuring safety and reducing risk of catastrophic events
- Audible and visual alarm provides immediate local alerts allowing corrective action to be taken quicker to eliminate the problem from becoming widespread
- Password protected set up menu ensures no errors by untrained personnel
- Optional BACnet communication from devices provides integration into building control system for automated control and centralized monitoring and alarming

### APPLICATIONS

- Hospital isolation wards
- Clean rooms
- Pharmaceutical
- Manufacturing
- Research labs
- Animal facilities

MODEL CHART			
Model*	Operating Range	Model**	Operating Range
RSM-1-A	$\pm 0.05$ in w.c.	RSM-1-B	$\pm 0.05$ in w.c.
RSM-2-A	$\pm 0.1$ in w.c.	RSM-2-B	$\pm 0.1$ in w.c.
RSM-3-A	$\pm 0.25$ in w.c.	RSM-3-B	$\pm 0.25$ in w.c.
RSM-4-A	$\pm 0.5$ in w.c.	RSM-4-B	$\pm 0.5$ in w.c.
RSM-5-A	$\pm 1$ in w.c.	RSM-5-B	$\pm 1$ in w.c.
RSM-6-A	$\pm 2.5$ in w.c.	RSM-6-B	$\pm 2.5$ in w.c.

\*Excitation/Output: 24 VAC/4-20 mA or 0-5 or 0-10 VDC.  
 \*\*Excitation/Output: 120 VAC/4-20 mA or 0-5 or 0-10 VDC.  
**Note:** For optional BACnet communication change end from -A to -C for 24 VAC power or from -B to -D for 120 VAC power models.

### SPECIFICATIONS

**Service:** Air or non-conductive, nonexplosive gases.  
**Accuracy:**  $\pm 0.5\%$  FS.  
**Temperature Limits:** 32 to 120°F (0 to 50°C).  
**Humidity Limits:** 5 to 95% relative humidity (non-condensing).  
**Thermal Effects:**  $\pm 0.03\%$  FS/°F ( $\pm 0.05\%$  FS/°C).  
**Pressure Limits:**  $\pm 15$  in w.c. ( $\pm 3.7$  kPa).  
**Supply Voltage:** Order code A (24 VAC): 18-32 VAC, 50 to 60 Hz; Order code B (120 VAC): 85-265 VAC, 50 to 60 Hz; Main supply voltage fluctuations up to 10%.  
**Power Requirements:** 5 W.  
**Power Consumption (Voltage output):** 5 W.  
**Output Signal:** Selectable 4-20 mA (2-wire), 0-5 VDC (3-wire), or 0-10 VDC (3-wire).  
**Switch Type:** SPST.  
**Loop Resistance (4-20 mA output):** 0 to 510  $\Omega$ .  
**Electrical Connection:** Removable terminal block.  
**Process Connections:** Barbed fittings for 3/16" ID tubing.  
**Enclosure Rating:** NEMA 1 (IP20) rated for indoor applications.  
**Housing:** Fire retardant plastic.  
**Mounting:** Mount to standard double gang metal electrical box using 4x4" plaster ring adapter.  
**Dimensions:** 8" H x 5.4" W x 1.8" D (20.3 H x 13.7 W x 4.1 D cm).  
**Weight:** 1.5 lb (680 g).  
**Communications:** BACnet MSTP ASC optional.  
**Agency Approvals:** CE, CSA (RSM only).

### ACCESSORIES

Model	Excitation/Output
A-285	Remote alarm annunciator with visible/audible alarm and acknowledge switch

Process Tubing Options: See page 455 (Gage Tubing Accessories)

# DIFFERENTIAL PRESSURE TRANSMITTER

## NEMA 4X Enclosure, 0.25% FS Accuracy

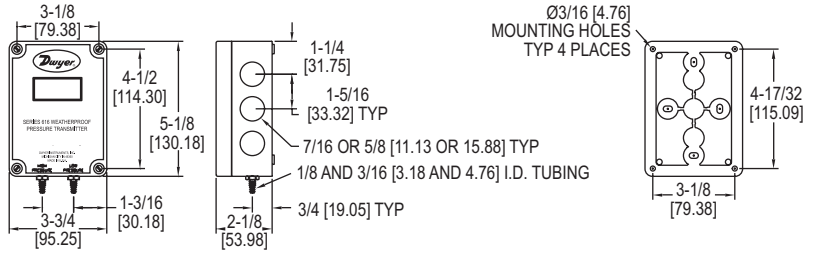

Positive, negative and differential pressures can be measured within a full span accuracy of  $\pm 0.25\%$  with the **Series 616W Differential Pressure Transmitter**. Units are enclosed in a polycarbonate case, rated NEMA 4X (IP66) and operate by sensing the pressure of air and compatible gases then sending a standard 4-20 mA output signal. Design enables operation in 2-wire current loops. A wide range of models are available factory calibrated to specific ranges. The span and zero controls are for use when checking calibration. They are not intended for re-ranging to a significantly different span. The LCD display allows local indication of pressure.

### FEATURES/BENEFITS

- NEMA 4X rated enclosure provides protection in harsh environments permitting outdoor monitoring or in areas where dust and particulate matter exists
- Easy to read LCD display provides immediate local alerts allowing corrective action to be taken quicker to eliminate the problem from becoming widespread
- Zero and span controls provides easy calibration checks and shorter installation time to get device running and monitoring

### APPLICATIONS

- Dust collection
- Outdoor HVAC
- Roof-top equipment

MODEL CHART		
Model	Range	Max. Pressure
616W-2-LCD	0 to 6 in w.c.	10 psig
616W-3-LCD	0 to 10 in w.c.	10 psig
616W-4-LCD	0 to 20 in w.c.	20 psig
616W-5-LCD	0 to 40 in w.c.	20 psig
616W-6-LCD	0 to 100 in w.c.	15 psig
616W-7-LCD	0 to 200 in w.c.	45 psig
616W-20B-LCD	0 to $\pm 10$ in w.c.	10 psig
616W-3M-LCD	0 to 2.5 kPa	68.9 kPa

Note: Units with "M" in the model number are metric units.

### SPECIFICATIONS

**Service:** Air and non-combustible, compatible gases.  
**Wetted Materials:** Consult factory.  
**Accuracy:**  $\pm 0.25\%$  FS @ 77°F (25°C), display accuracy  $\pm 0.5\%$ .  
**Stability:**  $\pm 1\%$  FS/yr.  
**Temperature Limits:** 14 to 185°F (-10 to 85°C).  
**Pressure Limits:** See chart.  
**Power Requirements:** 10-35 VDC (2-wire), 17-36 VDC, or isolated 21.6-33 VAC (3-wire).  
**Output Signal:** 4-20 mA (2-wire), 0-5 VDC, or 0-10 VDC (3-wire).  
**Zero and Span Adjustments:** Push-buttons.

**Loop Resistance:** Current output: 0 to 1250  $\Omega$  max; Voltage output: Load resistance 1 k $\Omega$  (min).  
**Current Consumption:** 40 mA (max).  
**Electrical Connections:** 3-wire removable European style terminal block for 16 to 26 AWG.  
**Process Connections:** Barbed, dual size to fit 1/8" and 3/16" (3.12 and 4.76 mm) ID rubber or vinyl tubing.  
**Enclosure Rating:** NEMA 4X (IP66).  
**Mounting Orientation:** Any orientation.  
**Weight:** Without LCD 8.8 oz. (249 g); with LCD 9.6 oz (272 g).  
**Agency Approvals:** CE.

### OPTIONS

To order add suffix:	Description
-NIST	NIST traceable calibration certificate
Example: 616W-3-LCD-NIST	

Process Tubing Options: See page 455 (Gage Tubing Accessories)

## SERIES 616WL

# DIFFERENTIAL PRESSURE TRANSMITTER

## Low Ranges Down to 0.25 in w.c. (60 Pa), NEMA 4X Housing (IP66)

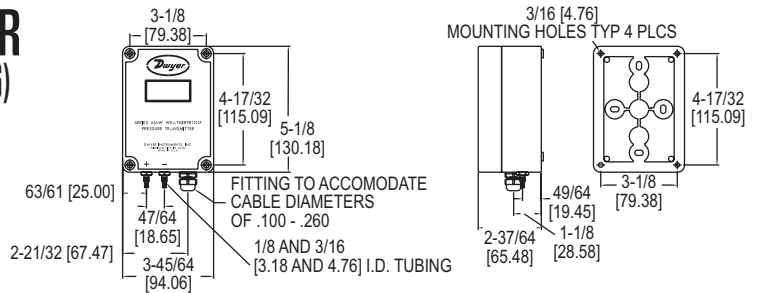

The **Series 616WL Differential Pressure Transmitter** senses very low pressures of air and non-combustible, compatible gases and sends a standard 4-20 mA output signal. All models, including those featuring the 3 digit LCD digital read-out, are factory calibrated to specific ranges as listed in the chart below. Positive, negative and differential pressures can be measured within a full span accuracy of  $\pm 0.50\%$ . This weatherproof unit is enclosed in a polycarbonate case, designed to meet (IP66/ NEMA 4X). Internal digital push-button zero and span allow for quick and simple field calibration.

### FEATURES/BENEFITS

- NEMA 4X rated enclosure provides protection in harsh environments permitting outdoor monitoring or in areas where dust and particulate matter exists
- Easy to read LCD display provides immediate local alerts allowing corrective action to be taken quicker to eliminate the problem from becoming widespread
- Zero and span controls provides easy calibration checks and shorter installation time to get device running and monitoring
- High precision accuracy at low pressure ranges provides exceptional accuracy for insuring tight-control and minimizing costly out of specification conditions

### APPLICATIONS

- Low pressure applications
- Outdoor HVAC
- Dust collection
- Roof-top equipment

OPTIONS	
To order add suffix:	Description
-NIST	NIST traceable calibration certificate
Example: 616WL-4-LCD-NIST	

### SPECIFICATIONS

**Service:** Air and non-combustible, compatible gases.  
**Wetted Materials:** Consult factory.  
**Accuracy:**  $\pm 0.50\%$  FS, display accuracy  $\pm 0.5\%$ .  
**Stability:**  $\pm 1\%$  FS/yr.  
**Temperature Limits:** 0 to 140°F (-17.8 to 60°C).  
**Compensated Temperature Limits:** 20 to 120°F (-6.67 to 48.9°C).  
**Pressure Limits:** See chart.  
**Thermal Effect:**  $\pm 0.02\%$  FS/°F (0.036% FS/°C).  
**Power Requirements:** 12-30 VDC (2-wire).  
**Output Signal:** 4-20 mA.

**Zero and Span Adjustments:** Digital, push-button adj.  
**Loop Resistance:** DC; 0 to 900  $\Omega$  max.  
**Current Consumption:** DC; 38 mA max.  
**Electrical Connections:** Screw-type terminal block.  
**Process Connections:** Barbed, dual size to fit 1/8" and 3/16" (3.12 and 4.76 mm) ID rubber or vinyl tubing.  
**Enclosure Rating:** NEMA 4X (IP66).  
**Mounting Orientation:** Vertical, consult factory for other position orientations.  
**Weight:** Without LCD 17 oz (482 g); with LCD 18 oz (510 g).  
**Agency Approvals:** CE.

MODEL CHART		
Model	Range	Max. Pressure
616WL-2-LCD	0 to 0.25 in w.c.	2 psig
616WL-4-LCD	0 to 1 in w.c.	4 psig
616WL-12-LCD	0 to $\pm 0.25$ in w.c.	2 psig
616WL-14-LCD	0 to $\pm 1$ in w.c.	4 psig
616WL-22-LCD	0 to 60 Pa	2 psig
616WL-32-LCD	0 to $\pm 60$ Pa	2 psig
616WL-25-LCD	0 to 250 Pa	4 psig
616WL-35-LCD	0 to $\pm 250$ Pa	4 psig

Process Tubing Options: See page 455 (Gage Tubing Accessories)

# DIFFERENTIAL PRESSURE TRANSMITTERS

Same Size as Standard Magnehelic® Differential Pressure Gage



DM-2000-LCD



DM-2100-LCD

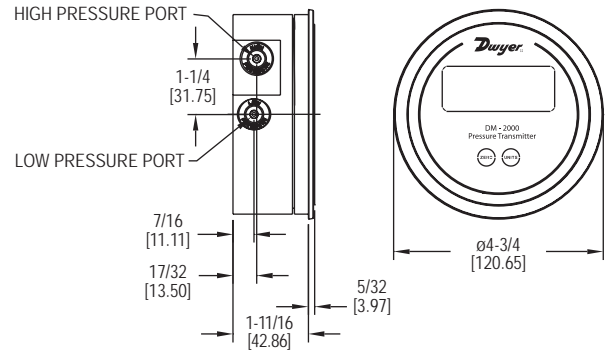

The Dwyer **Series DM-2000 Differential Pressure Transmitters** sense the pressure of air and compatible gases and sends a standard 4-20 mA output signal. The DM-2000 housing is specifically designed to mount in the same diameter cutout as a standard Magnehelic® gage. A wide range of models are available factory calibrated to specific ranges.

Pressure connections are inherent to the glass filled plastic molded housing making installation quick and easy. Digital push-button zero and span simplify calibration over typical turn-potentiometers. An optional 3.5 digit LCD shows process and engineering units. A single push-button allows field selection of 4 to 6 engineering units depending on range.

**FEATURES/BENEFITS**

- Zero and span controls provide easy calibration checks and shorter installation time to get device running and monitoring
- Quick response to pressure changes means no delay in signaling and alerting to critical situations
- Easy to read LCD display provides immediate local alerts allowing corrective action to be taken quicker to eliminate the problem from becoming widespread
- Same size as Magnehelic® simplifies field upgrade to digital pressure gage by reducing install steps
- Tamper proof button configuration to prevent accidental changes to the settings

**APPLICATIONS**

- Differential pressure across filters
- Fan control
- Static pressures in ducts or buildings

MODEL CHART						
Model	Range (in w.c.)	Pa	mm w.c.	mBar	kPa	psi
DM-2001-LCD	0 to .100	24.9	2.54	.249	-	-
DM-2002-LCD	0 to .250	62.2	6.35	.622	-	-
DM-2003-LCD	0 to .500	124.3	12.70	1.243	.124	-
DM-2004-LCD	0 to 1.000	249	25.4	2.49	.249	-
DM-2005-LCD	0 to 2.00	497	50.8	4.97	.497	-
DM-2006-LCD	0 to 3.00	746	76.2	7.46	.746	.108
DM-2007-LCD	0 to 5.00	1243	127.0	12.43	1.243	.180
DM-2012-LCD	0 to ±.250	0 to ±62.2	0 to ±6.35	0 to ±.622	-	-
DM-2013-LCD	0 to ±.500	0 to ±124.3	0 to ±12.70	0 to ±1.243	-	-
DM-2019-LCD	0 to ±.200	49.8	5.08	.498	-	-

**Note:** For white overlay change -20 to -21. **Example:** DM-2102-LCD

ACCESSORIES	
Model	Description
A-299	Surface mounting bracket
A-300	Flat flush mounting bracket
A-302F-A	303 SS static pressure tip with mounting flange; for 3/16" ID rubber or plastic tubing; 4" insertion depth; includes mounting screws
A-320-A	Instrument enclosure
A-489	4" straight static pressure tip with flange
SCD-PS	100-240 VAC/VDC to 24 VDC power supply

OPTIONS	
To order add suffix:	Description
-NIST	NIST traceable calibration certificate
<b>Example:</b> DM-2002-LCD-NIST	
-FC	Factory calibration certificate
<b>Example:</b> DM-2002-LCD-FC	

**SPECIFICATIONS**

- Service:** Air and non-combustible, compatible gases.
- Wetted Materials:** Consult factory.
- Accuracy:** ±1% FS at 70°F.
- Stability:** ±1% FS/yr.
- Temperature Limits:** 20 to 120°F (-6.67 to 48.9°C).
- Pressure Limits:** 10 psig (0.69 bar).
- Thermal Effect:** ±0.055% FS/°F (0.0999% FS/°C).
- Power Requirements:** 10-35 VDC (2 wire).
- Output Signal:** 4-20 mA.
- Zero and Span Adjustments:** Digital push-button zero and span.
- Loop Resistance:** DC: 0 to 1250 Ω maximum.
- Current Consumption:** DC: 38 mA max.
- Electrical Connections:** Screw-type terminal block.
- Display:** 3.5 digit LCD, 0.7" H.
- Process Connections:** 1/8" ID tubing.
- Mounting Orientation:** Vertical.
- Weight:** 4.8 oz (136 g).



# MAGNEHELIC® DIFFERENTIAL PRESSURE INDICATING TRANSMITTER

Same Size as Standard Magnehelic® Differential Pressure Gage



**Note:** Shown with optional -SS bezel.  
Backward compatible\* with Magnehelic® gage.

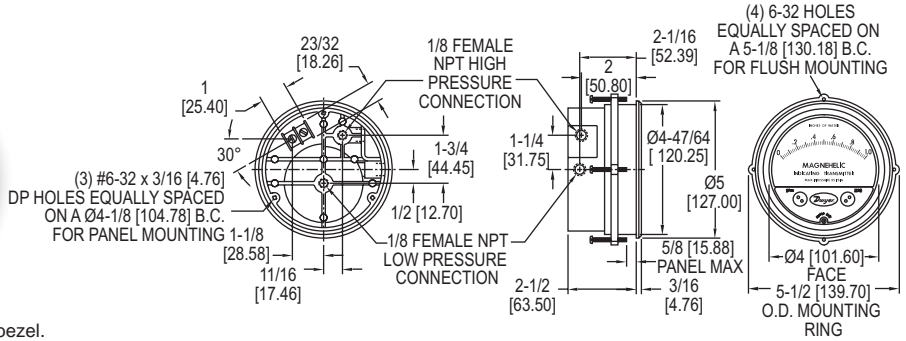

The **Series 605 Magnehelic® Differential Pressure Indicating Transmitter** provides for both visual monitoring and electronic control of very low differential pressure. The Series 605 is ideal for control applications in building HVAC systems where local indication is desired during routine maintenance checks or necessary when trouble shooting the system. The easily read dial gage is complimented by the two-wire, 4-20 mA control signal utilizing the time-proven Dwyer® Magnehelic® gage mechanical design and Series 600 transmitter technology. The two-wire design with terminal strip on the rear simplifies connection in any 4-20 mA control loop powered by a 10-35 VDC supply.

**FEATURES/BENEFITS**

- Easy to read gage permits viewing from far away
- Patented design provides quick response to pressure changes means no delay in signaling and alerting to critical situations
- Durable and rugged housing and high-quality components combined provides long-service life and minimized down-time
- Optional stainless steel bezel is the same installation diameter as Magnehelic® gage and simplifies field upgrade to 605 indicating transmitter

**APPLICATIONS**

- Monitor pressures in ducts, rooms, or total building pressures
- Filter monitoring
- Local indication of clean room pressures with process signal sent to control room

**MODEL CHART**

Model	Range in w.c.	Maximum Pressure	Electrical Accuracy ±%	Mechanical Accuracy ±%
605-00N	0.05-0-0.2	25 psi (1.7 bar)	4	4
605-11	0 to ±.25	25 psi (1.7 bar)	2	3
605-0	0 to .50	25 psi (1.7 bar)	2	3
605-1	0 to 1.0	25 psi (1.7 bar)	2	2
605-2	0 to 2.0	2 psi (13.79 kPa)	0.5	2
605-3	0 to 3.0	2 psi (13.79 kPa)	0.5	2
605-6	0 to 6.0	2 psi (13.79 kPa)	0.5	2
605-10	0 to 10	2 psi (13.79 kPa)	0.5	2
605-20	0 to 20.0	11 psi (75.8 kPa)	0.5	2
605-30	0 to 30	11 psi (75.8 kPa)	0.5	2
605-50	0 to 50	11 psi (75.8 kPa)	0.5	2
Model	Range in Pa	Maximum Pressure	Electrical Accuracy ±%	Mechanical Accuracy ±%
605-12	0 to ±60	25 psi (1.7 bar)	4	4
605-13	0 to ±100	25 psi (1.7 bar)	2	2
605-60PA	0 to 60	25 psi (1.7 bar)	2	4
605-125PA	0 to 125	25 psi (1.7 bar)	2	3
605-250PA	0 to 250	25 psi (1.7 bar)	2	2
605-500PA	0 to 500	2 psi (13.79 kPa)	0.5	2

**OPTIONS**

To order add suffix:	Description
-SS	304 brushed stainless steel bezel. *Backward compatible with standard Magnehelic® gage installation diameter
<b>Example:</b> 605-3-SS	
-NIST	NIST traceable calibration certificate
<b>Example:</b> 605-3-NIST	

**SPECIFICATIONS**

**GAGE SPECIFICATIONS**

- Service:** Air and non-combustible, compatible gases.
- Wetted Materials:** Consult factory.
- Accuracy:** See chart.
- Stability:** ±1% FS/yr.
- Pressure Limits:** See chart.
- Temperature Limits:** 20 to 120°F (-6.67 to 48.9°C).
- Process Connections:** 1/8" female NPT.
- Size:** 4" (101.6 mm) dial face, 5" (127 mm) OD x 2-11/16" (68.3 mm); -SS bezel: 4-3/4" (120.7 mm) OD x 2-21/32 (67.5 mm).
- Weight:** 1 lb 12.6 oz (811 g).
- Agency Approvals:** CE.

**TRANSMITTER SPECIFICATIONS**

- Accuracy:** See chart (includes linearity, hysteresis, repeatability).
- Temperature Limits:** 20 to 120°F (-6.67 to 48.9°C).
- Compensated Temperature Range:** 32 to 120°F (0 to 48.9°C).
- Thermal Effect:** ±0.025% FS/°F (0.045% FS/°C).
- Power Requirements:** 10-35 VDC (2-wire).
- Output Signal:** 4-20 mA.
- Zero and Span Adjustments:** Protected potentiometers.
- Loop Resistance:** DC: 0 to 1250 Ω max.
- Current Consumption:** DC: 38 mA max.
- Electrical Connections:** Screw terminal block.
- Mounting Orientation:** Diaphragm in vertical position. Consult factory for other position orientations.

**ACCESSORIES**

Model	Description
A-298	Flat aluminum bracket for flush mounting
A-370	Mounting bracket; flush mount Series 605 transmitter in bracket; bracket is then surface mounted; steel with gray hammertone epoxy finish

Static Fitting Options: See page 454 (Static Pressure Tips)  
Process Tubing Options: See page 455 (Gage Tubing Accessories)



# ATEX/IECEx APPROVED 605 DIFFERENTIAL PRESSURE INDICATING TRANSMITTER

Series 605 in Flame-Proof ATEX/IECEx Enclosure

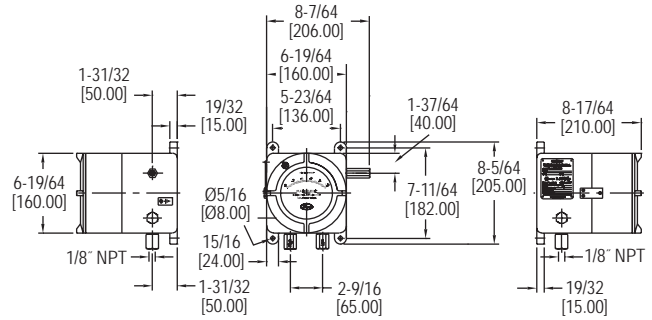

The Series AT2605 ATEX/IECEx Approved 605 Differential Pressure Indicating Transmitter provides for both visual monitoring and electronic control of very low differential pressure in hazardous locations. The easily read dial gage is complemented by the two-wire, 4-20 mA control signal utilizing the time-proven Dwyer® Magnehelic® gage mechanical design and Series 600 transmitter technology. The two-wire design simplifies any 4-20 mA control loop powered by a 10-35 VDC supply. Flame-proof enclosures are available in aluminum and can include a glass window for viewing process pressure on gage face.

### FEATURES/BENEFITS

- ATEX/IECEx housing provides all the capabilities and value of the Magnehelic® 605 in a flame & explosion proof enclosure
- Quick response to pressure changes means no delay in assessing critical situations
- Durable and rugged housing and high-quality components combined provides long-service life and minimized down-time
- High impact strength and high temperature rated for applications where hazardous environments exist

### APPLICATIONS

- Monitor pressures in ducts, rooms, or total building pressures
- Filter monitoring
- Local indication of clean room pressures with process signal sent to control room
- Hazardous area pressure measurement and transmitter

### SPECIFICATIONS

#### GAGE SPECIFICATIONS

**Service:** Air and non-combustible, compatible gases.  
**Wetted Materials:** Consult factory.  
**Accuracy:** See page reference ① below.  
**Pressure Limits:** See page reference ① below.  
**Temperature Limits:** 20 to 120°F (-6.67 to 48.9°C) (Note: Product temperature limits differ from case).  
**Size:** 4" (101.6 mm) dial face.

#### TRANSMITTER SPECIFICATIONS

**Accuracy:** See page reference ① below. Includes linearity, hysteresis, repeatability.  
**Compensated Temperature Range:** 32 to 120°F (0 to 48.9°C).  
**Thermal Effect:** ±0.025% FS/°F (0.045% FS/°C).  
**Stability:** ±1% FS/year.  
**Power Requirements:** 10-35 VDC (2-wire).  
**Output Signal:** 4-20 mA.  
**Zero and Span Adjustments:** Protected potentiometers on 605 face. Can access those by opening case. Allowed only in safe zone.  
**Loop Resistance:** DC: 0 to 1250 Ω max.  
**Current Consumption:** DC: 38 mA max.  
**Electrical Connections:** Screw terminal block.  
**Mounting Orientation:** Diaphragm in vertical position.  
**Enclosure Rating:** IP66. IP65 with option OPV, overpressure relief valve.  
**Housing Material:** Aluminum.  
**Finishing:** Texture epoxy coat RAL7038.  
**Process Connections:** 1/8" NPT female brass (SS optional). In presence of acetylene it is necessary to use SS.  
**Electrical Connections:** Two 1/2" NPT female. Cable gland not included.  
**Weight:** 12.6 lb (5.7 kg).  
**ATEX Certificate:** BVI 14ATEX0072.  
**Agency Approvals:** ATEX Compliant  $\text{CE}$  1370  $\text{Ex}$  II 2G Ex d IIC T6 Gb / II 2D Ex tb IIIC T85°C Db, -60°C ≤ Tamb ≤ +60°C IECEx Compliant: Ex d IIC T6 Gb / Ex tb IIIC T85°C Db.

MODEL CHART									
Example	AT2605	-00N	-X	-A	B	1	X	T2	AT2605-00N-X-AB1XT2
Series	AT2605								ATEX/IECEx approved 605 differential pressure indicating transmitter
Range		00N 11 0 1 2 3 6 10 20 30 50 60Pa 125Pa 250Pa 500Pa							.05 to 0 to .20 in w.c. .25 to 0 to .25 in w.c. 0 to .50 in w.c. 0 to 1.0 in w.c. 0 to 2.0 in w.c. 0 to 3.0 in w.c. 0 to 6.0 in w.c. 0 to 10.0 in w.c. 0 to 20.0 in w.c. 0 to 30 in w.c. 0 to 50 in w.c. 0 to 60 Pa 0 to 125 Pa 0 to 250 Pa 0 to 500 Pa
Construction			X						Standard construction
Housing				A					Aluminum
Cover					B O				Blind Glass top cover
Process Connection						1 2			1/8" NPT female brass ports 1/8" NPT female SS ports
Overpressure Plug							X OPV		Standard without overpressure relief valve Overpressure relief valve Material same as ports
Tag								T2	SS information label

USA: California Proposition 65  
 ⚠ WARNING: Cancer and Reproductive Harm - www.P65Warnings.ca.gov

①605 Ordering Page: See page 64 (Series 605)

# MAGNESENSE® II DIFFERENTIAL PRESSURE TRANSMITTER

Monitors Pressure, Air Velocity and Air Flow, BACnet or Modbus® Communications

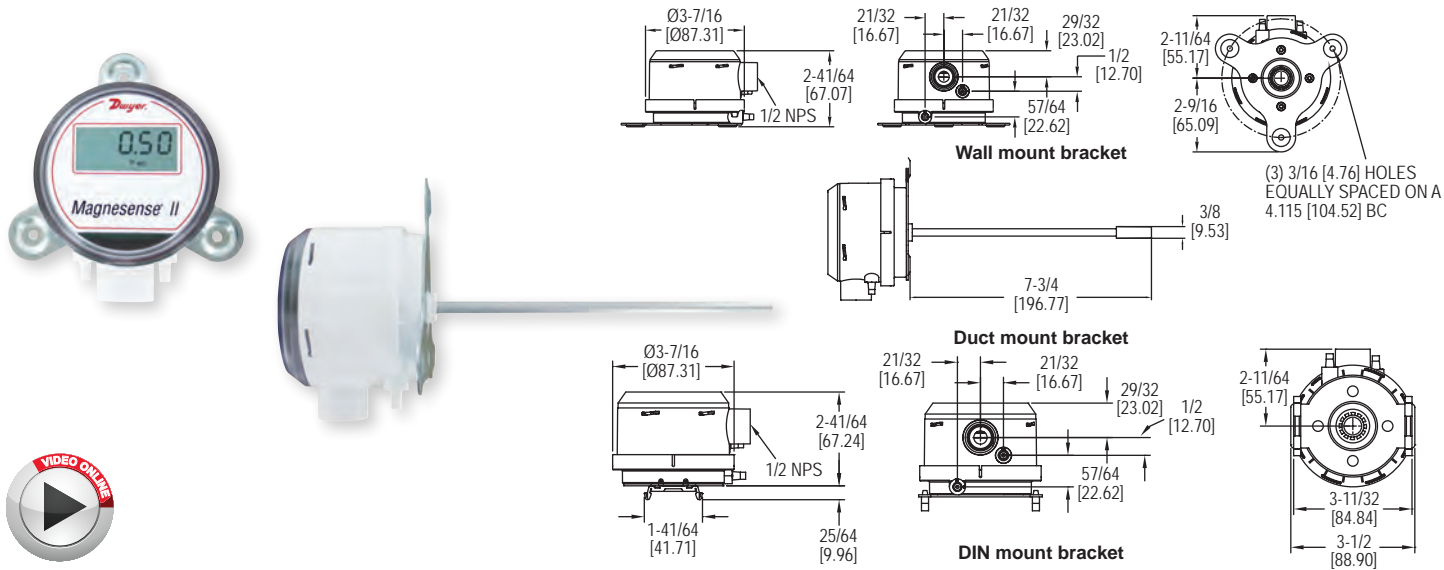

The **Series MS2 Magnesense® II Differential Pressure Transmitter** combines the proven stable piezo technology and the versatility of our original Series MS with additional features to reduce installation time and simplify ordering. Like the original Series MS, the second generation transmitter can be used as a linear pressure output or a linear velocity output with the square root extraction done in the transmitter. Additional parameters have been included to expand the square root capability to include flow measurements.

**FEATURES/BENEFITS**

- Field selectable ranges and output signal reduce inventory and the chances of ordering an incorrect part
- BACnet or Modbus® serial communications reduce wiring cost by daisy-chaining the transmitters
- Our integral field-upgradeable display or plug-in remote display tool save upfront material cost and allow for local viewing of measurements

**APPLICATIONS**

- Filter monitoring in air handler units
- Building pressure in pharmaceutical-semiconductor clean rooms
- Duct static pressure in commercial buildings
- Air velocity/flow in VAV systems

**SPECIFICATIONS**

**Supported Baud Rates:** 9600, 19200, 38400, 57600, 76800, 115200.  
**Data Size:** 8.  
**Parity:** None.  
**Stop Bits:** 1.  
**Service:** Air and non-combustible, compatible gases.  
**Wetted Materials:** Consult factory.  
**Typical Accuracy:** ±1% FS for 0.15 in w.c. (40 Pa), 0.25 in w.c. (50 Pa), 0.5 in w.c. (125 Pa), 2 in w.c. (500 Pa), 3 in w.c. (750 Pa), 5 in w.c. (1250 Pa), 10 in w.c. (2 kPa), 15 in w.c. (3 kPa), 25 in w.c. (5 kPa), 28 in w.c. (6.975 kPa); ±2% FS for 0.1 in w.c. (25 Pa), 1 in w.c. (250 Pa), and all bi-directional ranges.  
**Stability:** ±1% / year FSO.  
**Temperature Limits:** 0 to 150°F (-18 to 66°C).  
**Pressure Limits:** 1 psi max., operation; 10 psi burst.  
**Power Requirements:** 10-35 VDC (2-wire), 17-36 VDC or isolated 21.6-33 VAC (3-wire).  
**Output Signals:** 4-20 mA (2-wire), 0-5 VDC, 0-10 VDC (3-wire).  
**Response Time:** Adjustable: 0.5 to 15 sec. time constant. Provides a 95% response time of 1.5 to 45 seconds.  
**Zero & Span Adjustments:** Digital push-buttons.  
**Loop Resistance:** Current output: 0 to 1250 Ω max; Voltage output: Min. load resistance 1 kΩ.  
**Current Consumption:** 40 mA max.  
**Display (Optional):** 5 digit LCD.  
**Electrical Connections:** 3-wire removable European style terminal block for 16 to 22 AWG.  
**Electrical Entry:** 1/2" NPS thread.  
**Process Connection:** 3/16" ID tubing (5 mm ID); Max. OD 9 mm.  
**Enclosure Rating:** IP66.  
**Mounting Orientation:** Not position sensitive.  
**Weight:** 8.0 oz (230 g).  
**Agency Approvals:** BTL, CE.

MODEL CHART				
Model	in w.c.	Pa	mm w.c.	kPa
MS2-W101	0.10, 0.15, 0.25, 0.50	25, 40, 50, 125	2.5, 4, 6, 10	0.025, 0.04, 0.05, 0.125
MS2-W111	±0.10, ±0.15, ±0.25, ±0.50	±25, ±40, ±50, ±125	±2.5, ±4, ±6, ±10	±0.025, ±0.04, ±0.05, ±0.125
MS2-W102	1, 2, 3, 5	250, 500, 750, 1250	25, 50, 75, 125	0.25, 0.5, 0.75, 1.25
MS2-W112	±1, ±2, ±3, ±5	±250, ±500, ±750, ±1250	25, 50, 75, 125	0.25, 0.5, 0.75, 1.25
MS2-W103	10, 15, 25, 28	2500, 3500, 5000, 6975	250, 350, 500, 697.5	2.5, 3.5, 5.0, 6.975
	±10, ±15, ±25, ±28	±2500, ±3500, ±5000, ±6975	±250, ±350, ±500, ±697.5	±2.5, ±3.5, ±5.0, ±6.975

**Note:** For duct mount static probe change W to D. **Example:** MS2-D101  
 For DIN rail mounting change W to N. **Example:** MS2-N101

OPTIONS	
To order add suffix:	Description
-LCD	Units with display
<b>Example:</b> MS2-W101-LCD	
-BC	BACnet Communications
<b>Example:</b> MS2-W101-BC	
-MC	Modbus® Communications
<b>Example:</b> MS2-W101-MC	
-NIST	NIST traceable calibration certificate
<b>Example:</b> MS2-W101-NIST	
-FC	Factory calibration certificate
<b>Example:</b> MS2-W101-FC	

ACCESSORIES	
Model	Description
A-151	Cable gland for 5 to 10 mm diameter cable
A-MS2-LCD	Field upgradeable display
A-435-A	Remote display tool
A-480	Plastic static pressure tip
A-481	Installer kit; includes 2 plastic static pressure tips and 7 ft (2.1 m) of PVC tubing
A-489	4" 303 SS straight static pressure tip with flange
A-302F-A	4" 303 SS static pressure tip with mounting flange; for 3/16" ID rubber or plastic tubing
SCD-PS	100 to 240 VAC/VDC to 24 VDC power supply

Modbus® is a registered trademark of Schneider Automation, Inc.  
 Process Tubing Options: See page 455 (Gage Tubing Accessories)

# MAGNESENSE® DIFFERENTIAL PRESSURE TRANSMITTER

Monitors Pressure and Air Velocity



Standard MS with optional LCD

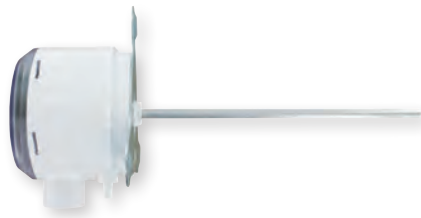
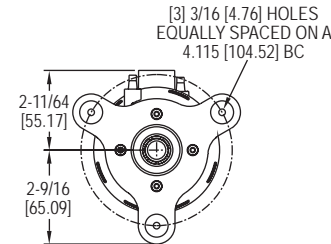
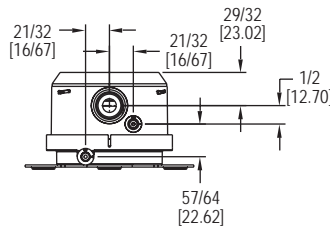
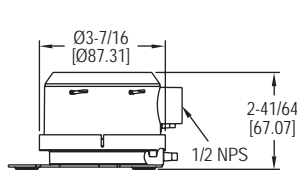

MS with optional LCD and static probe

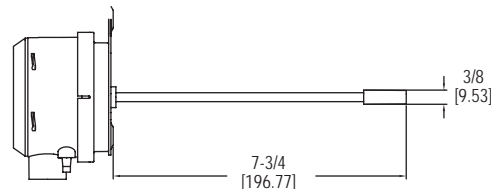

The Series MS Magnesense® Differential Pressure Transmitter is an extremely versatile transmitter for monitoring pressure and air velocity. This compact package is loaded with features such as:

**FEATURES/BENEFITS**

- Field selectable English or Metric ranges
- Field upgradeable LCD display
- Adjustable damping of output signal (with optional display)
- Ability to select a square root output for use with pitot tubes and other similar flow sensors

**APPLICATIONS**

- Building pressure monitoring
- Duct pressure monitoring
- Fan velocity measurement
- Zone differential pressure monitoring
- Filter condition monitoring

Along with these features, the patented magnetic sensing technology provides exceptional long term performance and enables the Magnesense® Differential Pressure Transmitter to be the single solution for your pressure and flow applications.

**SPECIFICATIONS**

<b>Service:</b> Air and non-combustible, compatible gases.	<b>Zero &amp; Span Adjustments:</b> Digital push-button.
<b>Wetted Materials:</b> Consult factory.	<b>Loop Resistance:</b> Current output: 0-1250 Ω max; Voltage output: min. load resistance 1 kΩ.
<b>Accuracy:</b> ±1% for 0.25" (50 Pa), 0.5" (100 Pa), 2" (500 Pa), 5" (1250 Pa), 10" (2 kPa), 15" (3 kPa), 25" (5 kPa); ±2% for 0.1" (25 Pa), 1" (250 Pa) and all bi-directional ranges.	<b>Current Consumption:</b> 40 mA max.
<b>Stability:</b> ±1% FS/year.	<b>Display (optional):</b> 4 digit LCD.
<b>Temperature Limits:</b> 0 to 150°F (-18 to 66°C).	<b>Electrical Connections:</b> 4-20 mA, 2-Wire: European style terminal block for 16 to 26 AWG; 0-10 V, 3-Wire: European style terminal block for 16 to 22 AWG.
<b>Pressure Limits:</b> 1 psi maximum, operation; 10 psi, burst.	<b>Electrical Entry:</b> 1/2" NPS thread; Accessory (A-151): Cable gland for 5 to 10 mm diameter cable.
<b>Power Requirements:</b> 10-35 VDC (2-wire); 17-36 VDC or isolated 21.6-33 VAC (3-wire).	<b>Process Connections:</b> 3/16" (5 mm) ID tubing. Maximum OD 9 mm.
<b>Output Signals:</b> 4-20 mA (2-wire); 0-5 V, 0-10 V (3-wire).	<b>Enclosure Rating:</b> NEMA 4X (IP66).
<b>Response Time:</b> Adjustable 0.5 to 15 s time constant. Provides a 95% response time of 1.5 to 45 seconds.	<b>Mounting Orientation:</b> Diaphragm in vertical position.
	<b>Weight:</b> 8.0 oz (230 g).
	<b>Agency Approvals:</b> CE.

MODEL CHART		
Model	Output	Selectable Ranges
MS-121*	4-20 mA	0.1 in, 0.25 in, 0.5 in w.c. (25, 50, 100 Pa)
MS-321*	0-10 V	0.1 in, 0.25 in, 0.5 in w.c. (25, 50, 100 Pa)
MS-721*	0-5 V	0.1 in, 0.25 in, 0.5 in w.c. (25, 50, 100 Pa)
MS-111*	4-20 mA	1 in, 2 in, 5 in w.c. (250, 500, 1250 Pa)
MS-311*	0-10 V	1 in, 2 in, 5 in w.c. (250, 500, 1250 Pa)
MS-711*	0-5 V	1 in, 2 in, 5 in w.c. (250, 500, 1250 Pa)
MS-131	4-20 mA	10 in w.c. (2 kPa)
MS-141	4-20 mA	15 in w.c. (3 kPa)
MS-151	4-20 mA	25 in w.c. (5 kPa)
MS-331	0-10 V	10 in w.c. (2 kPa)
MS-341	0-10 V	15 in w.c. (3 kPa)
MS-351	0-10 V	25 in w.c. (5 kPa)
MS-021	4-20 mA	±0.1 in, 0.25 in, 0.5 in w.c. (±25, 50, 100 Pa)
MS-221	0-10 V	±0.1 in, 0.25 in, 0.5 in w.c. (±25, 50, 100 Pa)
MS-621	0-5 V	±0.1 in, 0.25 in, 0.5 in w.c. (±25, 50, 100 Pa)

\*Note: For duct mount static pressure probe, change last digit from 1 to 2. Example: MS-122

ACCESSORIES	
Model	Description
A-435	Field upgradeable LCD
A-480	Plastic static pressure tip
A-481	Installer kit. Includes 2 plastic static pressure tips and 7 ft (2.1 m) of PVC tubing
A-489	4" straight static pressure tip with flange
A-302F-A	303 SS Static Pressure Tip with mounting flange. For 3/16" ID rubber or plastic tubing. 4" insertion depth. Includes mounting screws
SCD-PS	100-240 VAC/VDC to 24 VDC Power supply

OPTIONS	
To order add suffix:	Description
-LCD	Units with display
Example: MS-121-LCD	
-NIST	NIST traceable calibration certificate
Example: MS-021-NIST	
-FC	Factory calibration certificate
Example: MS-021-FC	

Process Tubing Options: See page 455 (Gage Tubing Accessories)

# ATEX/IECEx APPROVED MAGNESENSE® DIFFERENTIAL PRESSURE TRANSMITTER

Series MS in Flame-Proof ATEX/IECEx Enclosure

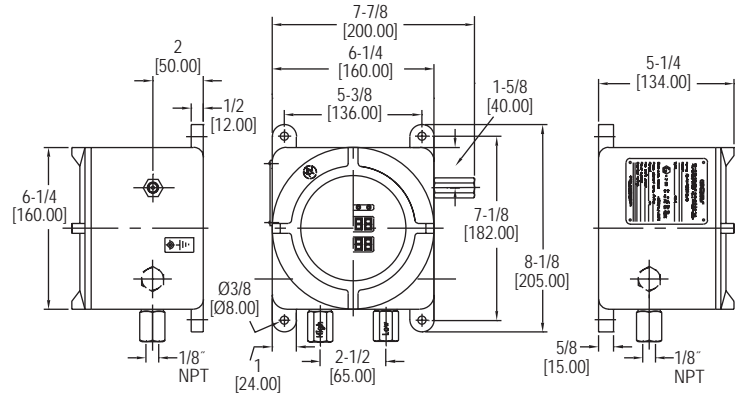

The Series AT2MS ATEX/IECEx Approved Magnesense® Differential Pressure Transmitter is an extremely versatile transmitter for monitoring pressure and air velocity in hazardous areas. This transmitter is loaded with features such as: field selectable English or metric ranges, field upgradeable LCD display, adjustable dampening of output signal and the ability to select a square root output for use with pitot tubes and other similar flow sensors. Along with these features, the magnetic sensing technology provides exceptional long term performance and enables the Magnesense® transmitter to be the solution for a myriad of pressure and flow applications. Flame-proof enclosures are available in aluminum and can include a glass window for viewing process on the LCD.

**FEATURES/BENEFITS**

- ATEX/IECEx housing provides all the capabilities and value of the MS2 in a flame & explosion proof enclosure
- Durable and rugged housing and high-quality components combined provides long-service life and minimized down-time
- High impact strength and high temperature rated for applications where hazardous environments exist

**APPLICATIONS**

- Monitor pressures in ducts, rooms, or total building pressures
- Filter monitoring
- Local indication of clean room pressures with process signal sent to control room
- Hazardous area pressure measurement and transmitter

**SPECIFICATIONS**

**Service:** Air and non-combustible, compatible gases.  
**Wetted Materials:** Consult factory.  
**Accuracy:** MS-X21: 0.5 in w.c. & 0.25 in w.c.: ±1%; 0.1 in w.c.: ±2%; 100 Pa & 50 Pa: ±1%; 25 Pa: ±2%. MS-X11: 5 in w.c. & 2 in w.c.: ±1%; 1 in w.c.: ±2%; 1250 Pa & 500 Pa: ±1%; 250 Pa: ±2% (@ standard conditions).  
**Stability:** ±1% FS/year.  
**Temperature Limits:** 0 to 150°F (-18 to 66°C) (Note: Product temperature limits differ from case).  
**Pressure Limits:** 1 psi max., operation; 10 psi, burst.  
**Power Requirements:** 10-35 VDC (2-wire); 17-36 VDC or isolated 21.6-33 VAC (3-wire).  
**Output Signals:** 4-20 mA (2-wire); 0-5 V, 0-10 V (3-wire).  
**Response Time:** Field adjustable 0.5 to 15 s time constant. Provides a 95% response time of 1.5 to 45 seconds.  
**Zero & Span Adjustments:** Digital push-button. In safe zone only.

**Loop Resistance:** Current output: 0 to 1250 Ω max.; Voltage output: min. load resistance 1 k Ω.  
**Current Consumption:** 40 mA max. Display: 4 digit LCD.  
**Electrical Wiring:** 4-20 mA, 2-wire: European style terminal block for 16 to 26 AWG. 0 to 10 V, 3-wire: European style terminal block 16 to 22 AWG.  
**Mounting Orientation:** Diaphragm in vertical position.  
**Enclosure Rating:** 4X IP66, IP65 with option OPV overpressure relief valve.  
**Housing Material:** Aluminum.  
**Finishing:** Texture epoxy coat RAL7038.  
**Process Connections:** 1/8" NPT female brass (SS optional). In presence of acetylene it is necessary to use SS.  
**Electrical Connections:** Two 1/2" NPT female. Cable gland not included.  
**Weight:** 11 lb (5 kg).  
**ATEX Certificate:** BVI 14ATEX0072.  
**Agency Approvals:** ATEX Compliant CE 1370 Ex II 2G Ex d IIC T6 Gb / II 2D Ex tb IIIC T85°C Db, -60°C ≤ Tamb ≤ +60°C IECEx Compliant: Ex d IIC T6 Gb / Ex tb IIIC T85°C Db.

MODEL CHART											
Example	AT2MS	-0	-1	1	-LCD	-A	O	1	X	T2	AT2MS-0-11-LCD-AO1XT2
Series	ATEX/IECEx approved Magnesense® differential pressure transmitter										
Output		0	1	2	3	6	7	8	9		Bidirectional, 4-20 mA Positive range, 4-20 mA Bidirectional, 0-10 VDC Positive range, 0-10 VDC Bidirectional, 0-5 VDC Positive range, 0-5 VDC Bidirectional, 0-5 VDC, 12 volt in Positive range, 0-5 VDC, 12 volt in
Range		1	2	3	4	5					1, 2, 5 in w.c. (200, 500, 1000 Pa) .1, .25, .5 in w.c. (25, 50, 100 Pa) 10 in w.c. (2 kPa) 15 in w.c. (3 kPa) 25 in w.c. (5 kPa)
Mounting			1								Wall
Display					LCD						With LCD
Housing						A					Aluminum
Cover							B	O			Blind Glass top cover
Process Connection								1	2		1/8" NPT female brass ports 1/8" NPT female SS ports
Overpressure Plug									X	OPV	Standard without overpressure relief valve Overpressure relief valve Material same as ports
Tag										T2	SS information label

\*Add on applies to range -2 only.



# INTRINSICALLY SAFE DIFFERENTIAL PRESSURE TRANSMITTER

For Hazardous Zone Pressure and Flow Applications

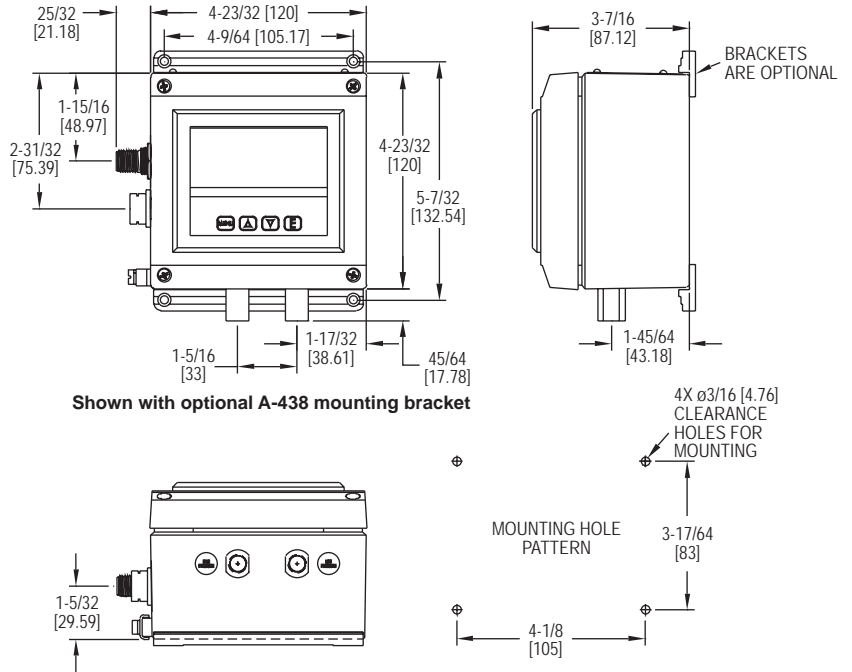

Shown with optional A-438 mounting bracket

The **Series ISDP Intrinsic Safe Differential Pressure Transmitter** provides a 4-20 mA process output, a robust NEMA 4X enclosure, plus a large LCD display that can be programmed to read in pressure, velocity or flow. The ISDP offers simplified programming via a Menu key that enables the user to select: security level; English or Metric engineering units; pressure, velocity or flow operation, K-factor for use with various Pitot tubes and flow sensors, circular or rectangular duct size for volumetric flow operation plus many more. The Series ISDP Differential Pressure Transmitter is powered on its two wire loop with 10-35 VDC via its integral M-12 four pin male connector. The ISDP provides a 0.5% full-scale accuracy on ranges from 0.25 in w.c. to 100 in w.c. as well as bi-directional models up to 10 in w.c. These features make the Series ISDP Differential Pressure Transmitter the ideal instrument for monitoring pressures or air flows in hazardous zones having a Class I Div. I Groups A, B, C, D; Class II Div. I Groups E, F, G; Class III Div. I ratings.

### FEATURES/BENEFITS

- NEMA 4X rated enclosure provides protection in harsh environments permitting outdoor monitoring or in areas where dust and particulate matter exists
- Easy to read LCD display provides immediate local alerts allowing corrective action to be taken quicker to eliminate the problem from becoming widespread
- Intrinsically safe for use in the specified hazardous locations meets specifications where pressure transmission and safety cannot be compromised
- Password protected set up menu helps to insure no errors by untrained personnel when accessing the powerful measurement capabilities of this device

### APPLICATIONS

- Hazardous zone pressure control applications
- Hazardous flow and control applications

MODEL CHART			
Model	Range (in w.c.)	Model	Range (in w.c.)
ISDP-002	0 to 0.25	ISDP-012	0 to ±0.25
ISDP-004	0 to 1	ISDP-014	0 to ±1.0
ISDP-006	0 to 5	ISDP-015	0 to ±2.5
ISDP-007	0 to 10	ISDP-016	0 to ±5.0
ISDP-008	0 to 25	ISDP-017	0 to ±10
ISDP-009	0 to 50		
ISDP-010	0 to 100		

OPTIONS	
To order add suffix:	Description
-NIST	NIST traceable calibration certificate
Example: ISDP-004-NIST	
-FC	Factory calibration certificate
Example: ISDP-004-FC	

### SPECIFICATIONS

**Service:** Air and non-combustible gases.  
**Wetted Materials:** Ranges 5 in w.c. and greater: glass, PVC, silicon, alumina ceramic, epoxy, RTV, gold, aluminum, stainless steel and nickel; Ranges 1 in w.c. and lower: stainless steel, silicone, gold and ceramic.  
**Housing Materials:** Aluminum, glass.  
**Accuracy:** ±0.5% at 77°F (25°C) including hysteresis and repeatability (after 1 hour warm-up).  
**Stability:** < ±1% per year.  
**Pressure Limits:** Ranges ≤ 2.5 in w.c. = 2 psi; 5 in w.c.: 5 psi; 10 in w.c.: 5 psi; 25 in w.c.: 5 psi; 50 in w.c.: 5 psi; 100 in w.c.: 9 psi.  
**Temperature Limits:** 32 to 140°F (0 to 60°C).  
**Compensated Temperature Limits:** 32 to 140°F (0 to 60°C).  
**Thermal Effects:** 0.020%/°F (0.036/°C) from 77°F (25°C).  
**Power Requirements:** 10-35 VDC.  
**Output Signal:** 4-20 mA DC.  
**Zero & Span Adjustments:** Accessible via menus.  
**Response Time:** 250 ms (damping set to 1).  
**Display:** 4 digit LCD 0.6" H.  
**Electrical Connections:** M-12 4 PIN Connector.  
**Process Connections:** 1/8" female NPT.  
**Enclosure Rating:** Designed to meet NEMA 4X (IP66).  
**Mounting Orientation:** Mount unit in vertical plane.  
**Weight:** 2 lb 10 oz (1.19 kg).  
**Agency Approvals:** CE: CENELEC EN 61326/55024: 2003; IEC 61000-4-2/3/4/6: 2001/2006/2004/2005; CENELEC EN 55011: 2006; 2004/108/EC EMC Directive. FM Intrinsically Safe CLI Div I GR: A, B, C, D; CLII Div I GR: E, F, G; CLIII Div I.

ACCESSORIES	
Model	Description
A-231	16' (5 m) shielded cable with 4 pin female M-12 connection
A-486	4.9' (1 m) shielded cable with 4 pin female M-12 connection
A-487	9.8' (3 m) shielded cable with 4 pin female M-12 connection
A-488	33' (10 m) shielded cable with 4 pin female M-12 connection
A-295	Female 4 pin M-12 to cable gland connector
MTL5541	Intrinsically safe galvanic isolator
MTL7706	Intrinsically safe zener barrier
A-438	Surface mounting brackets



SERIES 3100 | MERCOID® BY DWYER



# EXPLOSION-PROOF DIFFERENTIAL PRESSURE TRANSMITTER

HART®, Push-Button Configuration, Rangeability (100:1)



3100D

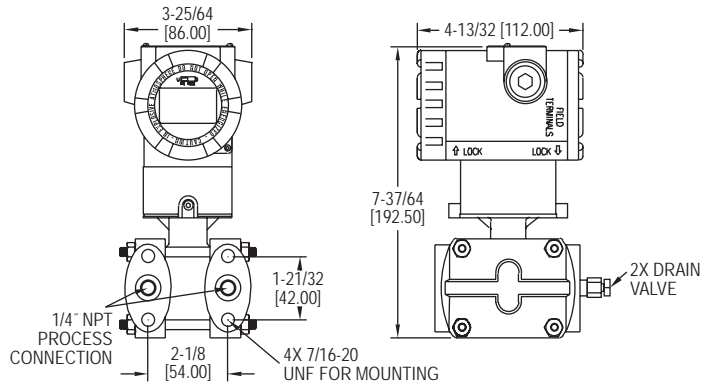

3100



Mercoïd® Series 3100 Explosion-Proof Smart Pressure Transmitter is a microprocessor-based high performance transmitter, which has flexible pressure calibration, push-button configuration, and programmable using HART® Communication. The Series 3100 is capable of being configured for differential pressure or level applications with the zero and span buttons. A field calibrator is not required for configuration. The transmitter software compensates for thermal effects, improving performance. EEPROM stores configuration settings and stores sensor correction coefficients in the event of shutdowns or power loss. The Series 3100 is FM or ATEX approved for use in hazardous (classified) locations. The 100:1 rangeability allows the smart transmitter to be configured to fit any application.

### FEATURES/BENEFITS

- Configurable using zero/span buttons means no calibrator required reducing time to install and running
- Range-ability and selectable engineering units, allows transmitter to fit many applications reducing the number of different transmitters to meet specifications
- High accuracy (±0.075%) provides exceptional measurement for ensuring tight-control and minimizing costly out of specification conditions
- Automatic sensor temperature compensation improves performance of device for accurate measurement under different operating environments
- Fail-mode process function stores configuration settings in the event of shutdown or power-loss provides for faster restart to getting application back on-line
- A HART® Communication programmable device provides a reliable, long-term solution for plant operators who seek the benefits of intelligent devices with digital communication

### APPLICATIONS

- Flow measurement
- Level monitoring
- Filter or pump differential pressure
- Critical process monitoring

### SPECIFICATIONS

**Service:** Compatible gases, steam, liquids or vapors.  
**Wetted Materials:** 316L SS, fluoroelastomer.  
**Accuracy:** ±0.075% FS (@ 20°C).  
**Rangeability:** 100:1 turn down.  
**Stability:** ±0.125% FSO/yr.  
**Temperature Limits:** Process: -40 to 248°F (-40 to 120°C); Ambient: Without LCD: -40 to 185°F (-40 to 85°C); With LCD: -22 to 176°F (-30 to 80°C).  
**Pressure Limits:** Max pressure: Range: -14.5 to 2000 psi; Burst pressure: 10000 psi.  
**Thermal Effect:** ±0.125% span/32°C.  
**Power Requirements:** 11.9-45 VDC.  
**Output Signal:** 4-20 mA / HART® Communication.  
**Response Time:** 0.12 s.  
**Damping Time:** 0.25 to 60 s.  
**Loop Resistance:** Operation: 0 to 1500 Ω; HART® Communication: 250 to 500 Ω.  
**Electrical Connection:** Two 1/2" female NPT conduit, screw terminal.  
**Process Connection:** 1/4" female NPT.  
**Display:** Optional 5 digit LCD.  
**Enclosure Rating:** NEMA 4X (IP66) and explosion-proof for Class I, Div I, Groups A, B, C and D.  
**Weight:** 8.6 lb (3.9 kg).  
**Agency Approvals:** CE, FM, ATEX option available (consult factory).

### MODEL CHART

Model	Calibrated Span (Min. to Max.)		Lower Range Limit		Upper Range Limit		LCD Display
3100D-2-FM-1-1	0.6 to 30 in w.c.	0.15 to 7.5 kPa	-30 in w.c.	-7.5 kPa	30 in w.c.	7.5 kPa	No
3100D-3-FM-1-1	1.5 to 150 in w.c.	0.373 to 37.3 kPa	-150 in w.c.	-37.3 kPa	150 in w.c.	37.3 kPa	No
3100D-4-FM-1-1	7.5 to 750 in w.c.	1.865 to 186.5 kPa	-750 in w.c.	-186.5 kPa	750 in w.c.	186.5 kPa	No
3100D-5-FM-1-1	1 to 100 psi	6.9 to 690 kPa	-100 psi	-690 kPa	100 psi	690 kPa	No
3100D-6-FM-1-1	3 to 300 psi	20.68 to 2068 kPa	-300 psi	-2068 kPa	300 psi	2068 kPa	No
3100D-2-FM-1-1-LCD	0.6 to 30 in w.c.	0.15 to 7.5 kPa	-30 in w.c.	-7.5 kPa	30 in w.c.	7.5 kPa	Yes
3100D-3-FM-1-1-LCD	1.5 to 150 in w.c.	0.373 to 37.3 kPa	-150 in w.c.	-37.3 kPa	150 in w.c.	37.3 kPa	Yes
3100D-4-FM-1-1-LCD	7.5 to 750 in w.c.	1.865 to 186.5 kPa	-750 in w.c.	-186.5 kPa	750 in w.c.	186.5 kPa	Yes
3100D-5-FM-1-1-LCD	1 to 100 psi	6.9 to 690 kPa	-100 psi	-690 kPa	100 psi	690 kPa	Yes
3100D-6-FM-1-1-LCD	3 to 300 psi	20.68 to 2068 kPa	-300 psi	-2068 kPa	300 psi	2068 kPa	Yes

Note: Consult factory for custom calibration.

# EXPLOSION-PROOF DIFFERENTIAL PRESSURE TRANSMITTER

HART®, Push-Button Configuration, Rangeability (100:1)

MODEL CHART															
Example	3100D	-2	-FM	-3	-1	-LEC	S2	A1	05	S	2	-05	-10	-LCD	3100D-2-FM-3-1-LECS2A105S2-05-10-LCD
Series	3100D														Explosion-proof differential pressure transmitter
Range		1 2 3 4 5 6 7													0 to 6 in w.c. 0 to 30 in w.c. 0 to 150 in w.c. 0 to 750 in w.c. 0 to 100 psi 0 to 300 psi 0 to 1000 psi
Approval			FM ATEX WP												FM approved ATEX approved Weatherproof only (only available with 316 SS housing)
Process Connection				1 3											1/4" female NPT Diaphragm seal
Electrical Connection					1										1/2" female NPT
Diaphragm Seal Type						LEC LED LEH LEL LFC LFD LFH LFL									2 extended diaphragm seals capillary type 1 extended diaphragm seal direct mount high side 1 extended diaphragm seal capillary type high side 1 extended diaphragm seal capillary type low side 2 flush diaphragm seals capillary type 1 flush diaphragm seal direct mount high side 1 flush diaphragm seal capillary type high side 1 flush diaphragm seal capillary type low side
Mounting Flange							S2 S3								2" (50 mm) 316L SS 3" (80 mm) 316L SS
Mounting Flange Rating								A1 A2 D1 D2 J1 J2							ANSI class 150# ANSI class 300# DIN PN 10/16 DIN PN 25/40 JIS 10 K JIS 20 K
Extension Length									00 05 10 15						No extension [standard for flush mount] 2" extension 4" extension 6" extension
Diaphragm Material										S P H T					316L SS diaphragm PTFE and 316L SS diaphragm Hastelloy C-276 diaphragm Tantalum diaphragm
Fill Fluid											2				Silicon oil (-40 to 400°F)
Capillary Length High Side												XX			0 to 20 feet
Capillary Length Low Side													XX		0 to 20 feet
Options														LCD SSH NIST CC	5 digit LCD 316 SS housing (Only available with WP approval) NIST calibration Custom calibration

CUSTOM CALIBRATION VALUES	
Primary Units	in w.c., ft in w.c., mm in w.c., in Hg, psig, g/cm <sup>2</sup> , kg/cm <sup>2</sup> , MPa, Pa, kPa, bar, mbar, Torr, Atm, mm Hg
Upper Range Limit	20 mA value
Lower Range Limit	4 mA value
Output	Linear or square root
Damping Time	0 to 60 seconds
Display Mode	Unit, %, mA, rotate
Display Units	Primary unit or Engineering unit
Engineering Units*	<b>Volumetric Flow Units</b> US gal/s, US gpm, US gal/hr, US gpd, imp gal/s, imp gpm, imp gal/hr, imp gpd, l/s, l/min, l/hour, ft/s, m/s, metric gal/day, metric l/day, ft <sup>3</sup> /s, ft <sup>3</sup> /min, ft <sup>3</sup> /h, ft <sup>3</sup> /day, m <sup>3</sup> /s, m <sup>3</sup> /min, m <sup>3</sup> /hr, m <sup>3</sup> /day, normal l/hr, normal m <sup>3</sup> /hr, standard ft <sup>3</sup> /min, barrels/s, barrels/min, barrels/hr, barrels/day <b>Mass Flow Units</b> g/s, g/min, g/hr, kg/s, kg/min, kg/hr, kg/day, metric ton/min, metric ton/hour, metric ton/day, lb/s, lb/min, lb/hr, lb/day, short ton/min, short ton/hr, short ton/day, long ton/hr, long ton/day <b>Volume Units</b> gallons, liters, imp gallons, m <sup>3</sup> , barrels, bushels, yd <sup>3</sup> , ft <sup>3</sup> , in <sup>3</sup> , bbl liq, normal cubic meter, normal liter, standard cubic feet, hectoliters
Engr. Upper Range Limit*	Engr. upper value
Engr. Lower Range Limit*	Engr. lower value
Engr Function*	Linear or square root

\*Engineering Units, Engr. Upper Range Limit, Engr. Lower Range Limit and Engr. Function values are only required if engineering unit is selected.

ACCESSORIES	
Model	Description
A-630	Stainless steel angle type bracket with SS bolts
A-631	Stainless steel flat type bracket with SS bolts
BBV-1F	Flanged 3-valve block manifold
BBV-22F	Flanged 5-valve block manifold
DevCom2000	HART® Communication Protocol Software

# SMART DIFFERENTIAL PRESSURE TRANSMITTER

HART® Communication, Push Button Configuration, Rangeability (Up to 25:1)

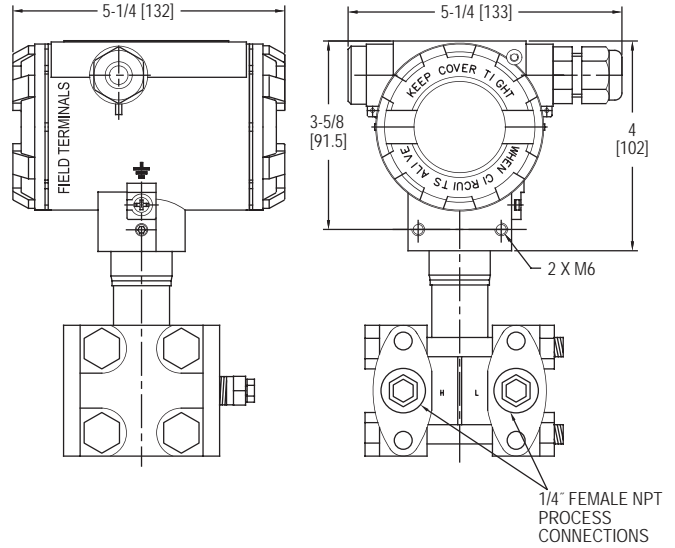

The **Series 3500 Smart Differential Pressure Transmitter** is a microprocessor-based high performance transmitter, which has flexible pressure calibration, push button configuration, and is programmable using HART® Communication. The Series 3500 is capable of being configured for differential pressure or level applications with the zero and span buttons. A field calibrator is not required for configuration. The transmitter software compensates for thermal effects, improving performance. EEPROM stores configuration settings and stores sensor correction coefficients in the event of shutdowns or power loss. The Series 3500 can be configured to be ATEX or IECEx approved for use in hazardous (classified) locations. The rangeability allows the smart transmitter to be configured to fit any application.

**FEATURES/BENEFITS**

- High accuracy ( $\pm 0.075\%$  FS)
- Rangeability (up to 25:1)
- Configurable using zero/span buttons (no calibrator required)
- Fail-mode process function
- Automatic ambient temperature compensation

**APPLICATIONS**

- Flow measurement
- Level monitoring
- Filter or pump differential pressure
- Critical process monitoring

MODEL CHART	
Model	Range
3500-AL-02-NF-2	-10 to 10 in w.c.
3500-AL-04-NF-2	0 to 30 in w.c.
3500-AL-08-NF-2	0 to 100 in w.c.
3500-AL-10-NF-2	-200 to 200 in w.c.
3500-AL-15-NF-2	0 to 1000 in w.c.
3500-AL-20-NF-2	0 to 15 psi
3500-AL-25-NF-2	0 to 100 psi

**Note:** Bar ranges are also available.

**SPECIFICATIONS**

**Service:** Compatible gases, steam, liquids or vapors.  
**Wetted Materials:** 316L SS and FPM; with diaphragm seal: 316L SS.  
**Accuracy:**  $\pm 0.075\%$  FS (@ 20°C).  
**Rangeability:** Up to 25:1 turn down.  
**Stability:**  $\leq 0.075\%$  FSO/3 years.  
**Temperature Limits:** Ambient: -40 to 185°F (-40 to 85°C); Process with -DS: -40 to 400°F (-40 to 204°C).  
**Thermal Effect:**  $< \pm 0.05\%$  span/10°C.  
**Power Requirements:** 10-55 VDC.  
**Output Signal:** 4-20 mA.  
**Response Time:** 16 to 480 ms (programmable).  
**Damping Time:** 0 to 60 seconds.  
**Electrical Connection:** Packing gland M20x1.5, two 1/2" female NPT conduit, screw terminal.  
**Process Connections:** 1/4" female NPT.  
**Enclosure Rating:** NEMA 4X IP66/IP67.  
**Agency Approvals:** CE; -IS, -FP suffix: ATEX Compliant CE 0518 II 2G Ex ia/db IIC T6/T5 Gb Ta<80°C, T5 / II 2D Ex ia/tb IIIC T85°C/T100°C Db. Type Certificate No. KDB 17ATEX0056X. ATEX Standards: EN 60079-0:2012+A11:2013, EN 60079-1:2014, EN 60079-11:2012, EN 60079-26:2015, EN 60079-31:2014 IECEx Compliant: Ex ia/db IIC T6/T5 Gb / Ex ia/tb IIIC T85°C/T100° Db. Certificate of Conformity IECEx KDB 17.0008X. IECEx Standards: IEC 60079-0:2011, IEC 60079-1:2014-06, IEC 60079-11:2011, IEC 60079-26:2006, IEC 60079-31:2013.



# SMART DIFFERENTIAL PRESSURE TRANSMITTER

HART® Communication, Push-Button Configuration, Rangeability (Up to 25:1)

MODEL CHART												
Example	3500	-AL	-01	-DS	-1	-SPRB	A	0	-1	-1	-NIST	3500-AL-01-DS-1-SPRBA0-1-1-NIST
Series	3500											Smart differential pressure smart transmitter
Housing		AL AS										Aluminum housing Stainless steel housing
Range			02 04 08 10 15 20 25 38 40 50 60									-10 to 10 in w.c. 0 to 30 in w.c. 0 to 100 in w.c. -200 to 200 in w.c. 0 to 1000 in w.c. 0 to 15 psi 0 to 100 psi 0 to 230 psi 0 to 1000 psi -2.5 to 2.5 in w.c. -1.5 to 1.5 psi
Process Connections				NF DS								1/4" female NPT adapter Diaphragm seal selection
Electrical Connections					1 2							Packing gland M20x1.5 Thread 1/2" female NPT
Diaphragm Seal Type						SPDH SPRB SPRH STDH STRB STRH						S-P flush diaphragm seal direct mount high side S-PK flush diaphragm seal capillary type both sides S-PK flush diaphragm seal capillary type high side S-T extended diaphragm seal direct mount high side S-TK extended diaphragm seal capillary type both sides S-TK extended diaphragm seal capillary type high side
Mounting Flange							A B C D					2" ANSI 2" DN50 3" ANSI 3" DN80
Extension Length								0 2 4 6				No extension, flush mount 2" (50 mm) 4" (100 mm) 6" (150 mm)
Capillary Length High Side									#			High side capillary length, 1 to 20 ft (increments of 1)
Capillary Length Low Side										#		Low side capillary length, 1 to 20 ft (increments of 1)
Options											FP IS MT NIST GB SB ST	ATEX/IECEx flameproof ATEX/IECEx intrinsically safe Stainless steel tag plate mounted on wire NIST traceable calibration certificate 2" galvanized steel mounting bracket 2" SS mounting bracket Stainless steel plate riveted to the housing

ACCESSORIES	
Model	Description
A-630	Stainless steel angle type bracket with SS bolts
A-631	Stainless steel flat type bracket with SS bolts
BBV-0N	2-valve block manifold
DevCom2000	HART® communication protocol software

# INTRINSICALLY SAFE DIFFERENTIAL PRESSURE TRANSMITTER

Ranges Down to 0.1 in w.c., FM Approved, NEMA 4X

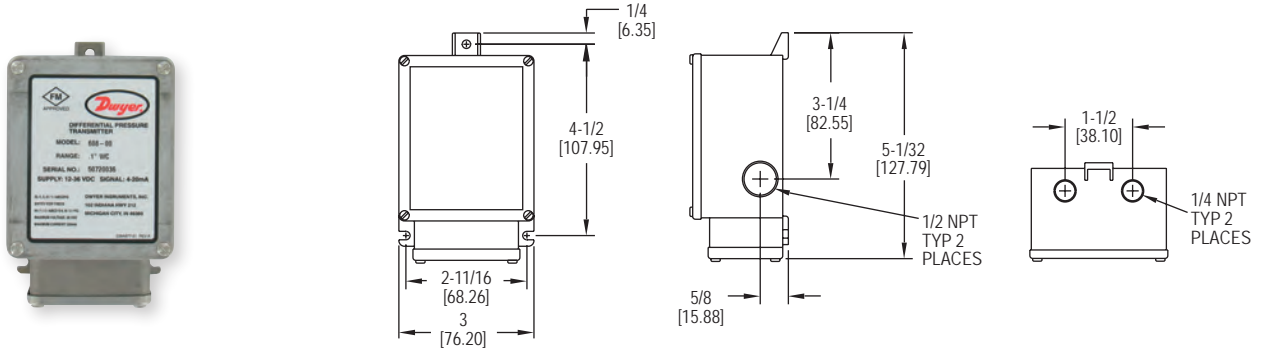

The Dwyer **Series 608 Intrinsic Safe Differential Pressure Transmitter** converts positive, negative (vacuum), or differential pressures of clean, dry air or other non-conductive, non-corrosive gases into a standard two wire, 4 to 20 mA output signal. The use of an ultra-thin silicon diaphragm enables precision measurement of differential pressures as low as 0.1 in w.c. while withstanding high static working pressures up to 100 psig (6.89 bar). The Series 608 transmitters are FM approved intrinsically safe for use in the specified hazardous locations when used with an approved intrinsic safety barrier. The rugged NEMA 4X, stainless steel housing makes this transmitter ideal for use in industrial and process plant environments.

**FEATURES/BENEFITS**

- High accuracy at low pressure ranges provides exceptional measurement for ensuring tight-control and minimizing costly out of specification conditions
- Intrinsically safe for use in the specified hazardous locations meets specifications where pressure transmission and safety cannot be compromised
- NEMA 4X rated enclosure provides protection in harsh environments permitting outdoor monitoring or in areas where dust and particulate matter exists

**APPLICATIONS**

- Lab fume hood control
- Clean room applications
- Flow measurements and control
- Filter monitoring
- Furnace draft measurement
- Process control

MODEL CHART	
Model	Range (in w.c.)
608-02	0 to 0.5
608-03	0 to 1.0
608-04	0 to 2.0
608-05	0 to 5.0
608-06	0 to 10.0
608-07	0 to 25.0
608-01B	0 to ±0.25
608-13B*	0 to ±1.0
608-04B	0 to ±2.0

\*Models have a ±0.25% FS accuracy.

**SPECIFICATIONS**

**Service:** Clean/dry air and compatible, combustible gases. (see Agency Approvals for FM ratings).  
**Wetted Materials:** Consult factory.  
**Accuracy:** ±0.5% or ±0.25% full-scale.  
**Stability:** ±0.5% FS/year.  
**Pressure Limits:** 100 psig (6.89 bar); 15 psid (1.03 bar).  
**Temperature Limits:** -20 to 185°F (-28 to 85°C).  
**Compensated Temperature Range:** 0 to 160°F (-18 to 71°C).  
**Thermal Effect:** 0.5% Accuracy: ±0.02% FS/°F; 0.25% Accuracy: ±0.01% FS/°F.  
**Power Requirements:** 12 to 36 VDC (2-wire).  
**Output Signal:** 4 to 20 mA DC.  
**Zero and Span Adjustments:** Potentiometers for zero and span.  
**Response Time:** 250 ms.  
**Loop Resistance:** DC: 0 to 1045 Ω max.  
**Electrical Connections:** Screw terminal: Two 1/2" female NPT conduit.  
**Process Connections:** Two 1/4" female NPT.  
**Enclosure Rating:** NEMA 4X (IP66).  
**Weight:** 2 lb (0.9 kg).  
**Agency Approvals:** FM approved intrinsically safe for use in Class I, Div. 1, Groups A, B, C, D; Class II, Div. 1, Groups E, F, G; Class III, Div. 1 when wired with approved intrinsically safe barrier. Entity parameters: V<sub>max</sub>= 36 VDC; I<sub>max</sub>= 250 mA; C<sub>i</sub>=12 nF; L<sub>i</sub>=0 mH.

**OPTIONS**

Use order code:	Description
NISTCAL-PT1	NIST traceable calibration certificate

**ACCESSORIES**

Model	Description
MTL5541	Intrinsically safe galvanic isolator
MTL7706	Intrinsically safe zener barrier

# FIXED RANGE DIFFERENTIAL PRESSURE TRANSMITTER

Explosion-Proof, 0.5% Accuracy

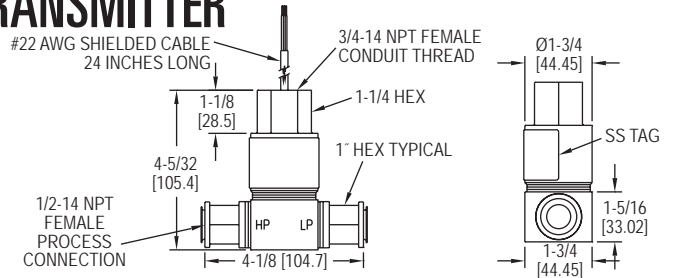

**Series 636D Fixed Range Differential Pressure Transmitter** can be used for measuring pressures of liquids, gases & vapors. All available ranges have an excellent 0.5% FS accuracy with a 4-20 mA Output standard or optional 1-5 VDC output. The NEMA 4 housing is an all 316 welded construction that is designed to withstand the harshest environmental conditions. With all 316L wetted materials, this transmitter is compatible with most media. These units are CSA approved explosion-proof for use in the specified hazardous locations and meet NACE standards for off-shore applications.

**FEATURES/BENEFITS**

- NEMA 4X rated enclosure provides protection in harsh environments permitting outdoor monitoring or in areas where dust and particulate matter exists
- Explosion-proof device for use in hazardous areas
- Versatile, high-accuracy device for liquid or gas supports designs requiring more precise measurements in support of application

**APPLICATIONS**

- Pump differential pressure
- Critical process monitoring
- Off shore applications

MODEL CHART			
Model	Range	Model	Range
4 to 20 mA Out		1 to 5 VDC Out	
636D-0	0 to 6 psid	636D-0-LP	0 to 6 psid
636D-1	0 to 15 psid	636D-1-LP	0 to 15 psid
636D-2	0 to 30 psid	636D-2-LP	0 to 30 psid
636D-3	0 to 60 psid	636D-3-LP	0 to 60 psid
636D-4	0 to 100 psid	636D-4-LP	0 to 100 psid
636D-5	0 to 150 psid	636D-5-LP	0 to 150 psid
636D-6	0 to 200 psid	636D-6-LP	0 to 200 psid
636D-7	0 to 300 psid	636D-7-LP	0 to 300 psid
636D-8	0 to 500 psid	636D-8-LP	0 to 500 psid

**SPECIFICATIONS**

**Service:** Compatible gases, liquids, or vapors.  
**Wetted Materials:** Types 316L SS.  
**Accuracy:** BFS: ±0.5% FS (includes linearity, hysteresis, and repeatability).  
**Stability:** ±1.0 FS/yr.  
**Pressure Limits:** 3 x full-scale differential pressure; Burst: 2500 psig.  
**Temperature Limits:** Ambient operating: -40 to 140°F (-40 to 60°C); Process interface: -40 to 212°F (-40 to 100°C); Storage: -40 to 212°F (-40 to 100°C).  
**Compensated Temperature Range:** -20 to 160°F (-29 to 71°C).  
**Thermal Effect:** ±2% FS/50°F (reference to 77°F).  
**Power Requirements:** 12-30 VDC for 4-20 mA outputs; 8-14 VDC for 1-5 VDC outputs, both with reverse polarity protection.  
**Output Signal:** 4-20 mA DC or 1-5 VDC.

**Zero and Span Adjustment:** Fixed.  
**Response Time:** 20 ms.  
**Loop Resistance:** 900 Ω max @ 30 VDC for current outputs. For voltage outputs, minimum lead resistance 50k ohms.  
**Current Consumption:** 4-20 mA for current output models; 3 mA for voltage output models.  
**Electrical Connections:** 2 ft, 22 AWG cable; 3/4" female NPT conduit.  
**Process Connections:** Two 1/2" female NPT.  
**Enclosure Rating:** NEMA 4 (IP56).  
**Mounting Orientation:** ±0.05 psi/90° rotation from horizontal.  
**Weight:** 1.8 lb (0.82 kg).  
**Agency Approvals:** CSA approved explosion-proof for Class I, Division 1, Groups B, C, and D; Class II, Groups E, F, and G; Class III.

**OPTIONS**

Use order code:	Description
NISTCAL-PT1	NIST traceable calibration certificate

**SERIES 655A**

# 316 WET/WET DIFFERENTIAL PRESSURE TRANSMITTER

Ranges Down to 3 in w.c., 6-Point NIST Certificate Included

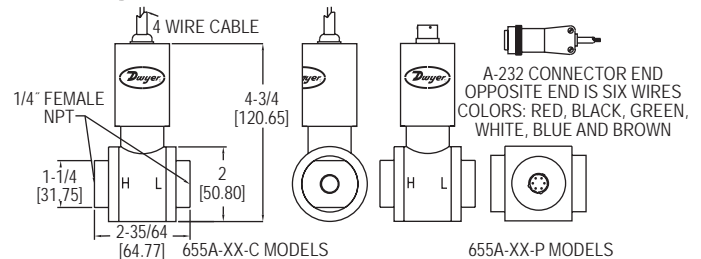

The **Series 655A 316 Wet/Wet Differential Pressure Transmitter** is designed for high static/low DP applications designed especially for the End Users and OEM's where extreme overpressure and high performance of 0.25% accuracy and stability are required at ranges down to 3 in w.c. Each unit includes a 6-point NIST certificate of calibration which demonstrates the unit's high level of performance.

**FEATURES/BENEFITS**

- Extreme overpressure and stability at low ranges provides durable device for OEM and end-user applications
- High-accuracy device for low differential pressure designs requiring more precise measurements in support of application
- NIST certificate available to demonstrate high-level of performance

**APPLICATIONS**

- Pump differential pressure
- High accuracy/low differential pressure OEM applications
- Critical process monitoring

MODEL CHART			
Model	Range	Model	Range
655A-00-C	0 to 3 in w.c.	655A-00-P	0 to 3 in w.c.
655A-01-C	0 to 5 in w.c.	655A-01-P	0 to 5 in w.c.
655A-02-C	0 to 8 in w.c.	655A-02-P	0 to 8 in w.c.
655A-03-C	0 to 10 in w.c.	655A-03-P	0 to 10 in w.c.
655A-04-C	0 to 15 in w.c.	655A-04-P	0 to 15 in w.c.
655A-05-C	0 to 20 in w.c.	655A-05-P	0 to 20 in w.c.
655A-06-C	0 to 1 psid	655A-06-P	0 to 1 psid
655A-07-C	0 to 2 psid	655A-07-P	0 to 2 psid

**Note:** Change 'C' to 'P' for optional 6 pin male connection.

**SPECIFICATIONS**

**Service:** Compatible gases or liquids.  
**Wetted Materials:** 316L SS.  
**Accuracy:** ±0.25% BFS, RSS (combined effect of non-linearity, hysteresis, and repeatability).  
**Stability:** ≤ ±0.25% FSO/yr.  
**Temperature Limits:** -20 to 200°F (-29 to 93°C).  
**Compensated Temperature Limits:** 0 to 170°F (-17.8 to 76.7°C).  
**Pressure Limits:** 1000 psi (68.95 bar) continuous; 3000 psi (206.8 bar) burst.  
**Thermal Effects:** ±1.5% FS oven comp. temperature range.  
**Power Requirements:** 8-38 VDC.  
**Output Signal:** 4-20 mA.  
**Static Pressure Effects:** On zero: ≤ ±0.25% FSO per 1000 psi; on span: ≤ ±0.5% of reading per 1000 psi.  
**Response Time:** < 10 ms.  
**Loop Resistance:** 1500 Ω.  
**Electrical Connections:** Cable exit with 24" cable; optional 6-pin connector.  
**Process Connections:** 1/4" NPT female.  
**Enclosure Rating:** Designed to meet NEMA 4X (IP66).  
**Mounting Orientation:** Mount in vertical position: zero shifts up to ±1 in w.c. depending on orientation.  
**Weight:** 18 oz (510 g).

**ACCESSORIES**

Model	Description
A-232	Connection with cable (3'); for 6 pin connection models

# WET/WET DIFFERENTIAL PRESSURE TRANSMITTERS

0.5% Accuracy, NEMA 4X (IP66) Enclosure

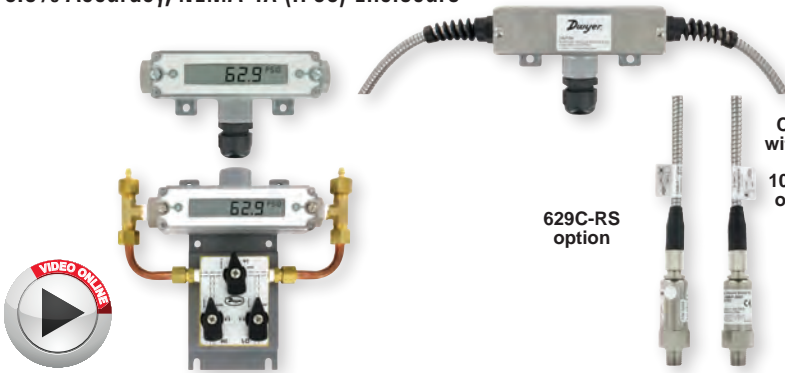

Conduit housing with remote sensor available in 10' or 20' shielded or armored cable

629C-RS option

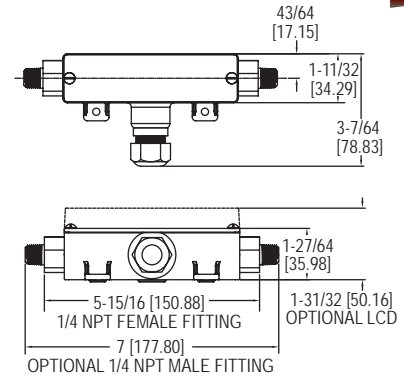

The Series 629C Wet/Wet Differential Pressure Transmitters monitor differential pressure of air and compatible gases and liquids with 0.5% accuracy. The design employs dual pressure sensors converting pressure changes into a standard 4-20 mA output signal or field selectable voltage. Small internal volume and minimal moving parts result in exceptional response and reliability. The terminal block, as well as a zero adjustment button, are easily accessed under the top cover. The Series 629C Differential Pressure Transmitter is designed to meet NEMA 4X (IP66) construction.

**FEATURES/BENEFITS**

- Powered by either DC or AC - take advantage of most readily available power source reducing installation costs
- Optional LCD does not need a separate power supply - lowers installed cost
- Selectable voltage range - provides flexible choice for changing design or inputs for process/HVAC controllers being used to monitor and control
- Push-button zero (versus trim pot) - more simple zeroing provides easy install and calibration reducing installation time and possibility of operator error
- Optional LCD indicator provides local status to identify operational condition
- Remote sensor option reduces installation labor and material

**APPLICATIONS**

- Flow elements
- Heat exchangers
- Filters
- Coils
- Chiller
- Pumps

**SPECIFICATIONS**

**Service:** Compatible gases and liquids.  
**Wetted Materials:** Without valve: 316, 316L SS. Additional wetted parts with valve option: Buna-N, silicone grease, PTFE, brass 360, copper, and reinforced copolymer.  
**Accuracy:** ±0.5% FS (includes linearity, hysteresis & repeatability).  
**Stability:** ±1% FS/year.  
**Temperature Limits:** 0 to 200°F (-18 to 93°C).  
**Compensated Temperature Limits:** 0 to 175°F (-18 to 79°C).  
**Pressure Limits:** See Table 1.  
**Thermal Effects:** Avg 0.04%/°F (0.072%/°C) (includes zero and span).  
**Power Requirements:** 2-wire: 10-35 VDC; 3-wire: 13-35 VDC or isolated 16-33 VAC (reverse polarity protected).  
**Output Signal:** 2-wire: 4-20 mA; 3-wire: Field selectable 0-5, 1-5, 0-10, or 2-10 VDC.

**Zero and Units:** Push-buttons inside conduit enclosure.  
**Response Time:** 400 msec.  
**Loop Resistance:** Current output: 0 to 1250 Ω (max), Rmax = 50(Vps-10); Voltage output: Minimum load resistance = 5 kΩ.  
**Current Consumption:** 28 mA (max).  
**Electrical Connections:** Removeable terminal block; 1/2" female NPT conduit.  
**Process Connections:** 1/4" female or male NPT.  
**Display:** Optional 4-1/2 digit LCD field attachable display.  
**Enclosure Rating:** Designed to meet NEMA 4X.  
**Mounting Orientation:** Not position sensitive.  
**Weight:** 629C-XX-CH: 10.1 oz (286 g); 629C-XX-R2-P1-E5-XX: 2.3 lbs (1.04 kg); 629C-XX-R6-P1-E5-XX: 4.55 lbs (2.06 kg).  
**Agency Approvals:** CE.

MODEL CHART								
Example	629C	-01	-CH	-P1	-E1	-S1	-3V	629C-01-CH-P1-E1-S1-3V
Series	629C							Wet/wet differential pressure transmitter
Range		01 02 03 04 05 06 07 08 09						0 to 5 psid 0 to 10 psid 0 to 25 psid 0 to 50 psid 0 to 100 psid 0 to 150 psid 0 to 200 psid 0 to 300 psid 0 to 500 psid
		11 12 13 14 15 16 17 18 19						0 to 0.5 bar differential 0 to 1 bar differential 0 to 2 bar differential 0 to 4 bar differential 0 to 6 bar differential 0 to 10 bar differential 0 to 15 bar differential 0 to 20 bar differential 0 to 30 bar differential
Housing			CH R1 R2 R5 R6					Conduit housing, NEMA 4X (IP66) Conduit housing, NEMA 4X (IP66) with Remote Sensor and 10' shielded cable Conduit housing, NEMA 4X (IP66) with Remote Sensor and 20' shielded cable Conduit housing, NEMA 4X (IP66) with Remote Sensor and 10' armored cable Conduit housing, NEMA 4X (IP66) with Remote Sensor and 20' armored cable
Process Connection				P1 P2 P3 P4				1/4" male NPT 1/4" female NPT 1/4" male BSPT 1/4" female BSPT
Electrical Connection					E1 E2 E3 E5 E9			Cable gland with 3' of prewired cable Cable gland with 6' of prewired cable Cable gland with 9' of prewired cable 1/2" female NPT conduit M-12 4 pin connector
Signal Output						S1 S3		4-20 mA Field selectable 0-5, 1-5, 0-10, 2-10 VDC
Options							3V AT FC LCD NIST	3-way valve Aluminum tag Factory calibration certificate LCD indication NIST traceable certificate

RANGE			
Range Number	Range	Working Pressure*	Over Pressure
01	0 to 5 psid	10 psi	50 psi
02	0 to 10 psid	20 psi	50 psi
03	0 to 25 psid	50 psi	120 psi
04	0 to 50 psid	100 psi	250 psi
05	0 to 100 psid	200 psi	500 psi
06	0 to 150 psid	300 psi	750 psi
07	0 to 200 psid	400 psi	1000 psi
08	0 to 300 psid	600 psi	1200 psi
09	0 to 500 psid	1000 psi	2000 psi
11	0 to 0.5 bar differential	1 bar	3 bar
12	0 to 1 bar differential	2 bar	8 bar
13	0 to 2 bar differential	4 bar	8 bar
14	0 to 4 bar differential	8 bar	18 bar
15	0 to 6 bar differential	12 bar	18 bar
16	0 to 10 bar differential	20 bar	50 bar
17	0 to 15 bar differential	30 bar	60 bar
18	0 to 20 bar differential	40 bar	80 bar
19	0 to 30 bar differential	60 bar	120 bar

\*Pressures exceeding the working pressure limit may cause a calibration shift of up to ±3% of full-scale.  
**Note:** Over pressure of all models with 3-way valve is 100 psi.

ACCESSORIES	
Model	Description
A-155	Cable gland with 1/2" NPT male
A-228	12" SS flex hose
A-62X-LCD	Field-upgradeable LCD
BBV-1B	Mini SS 3-valve block manifold

USA: California Proposition 65  
 ⚠WARNING: Cancer and Reproductive Harm  
[www.P65Warnings.ca.gov](http://www.P65Warnings.ca.gov)



# DIFFERENTIAL PRESSURE TRANSMITTERS

## High Accuracy, IP65 Enclosure

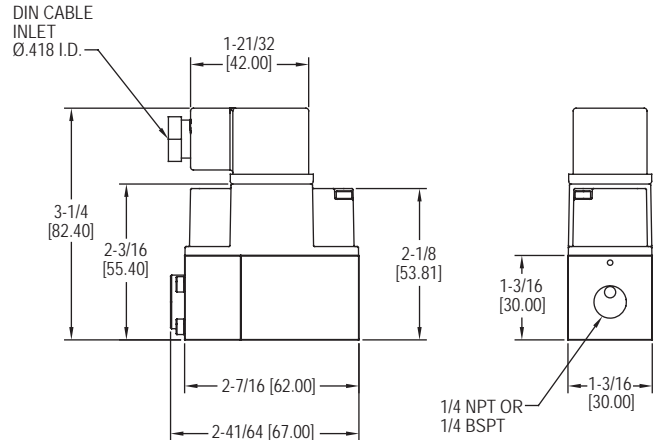
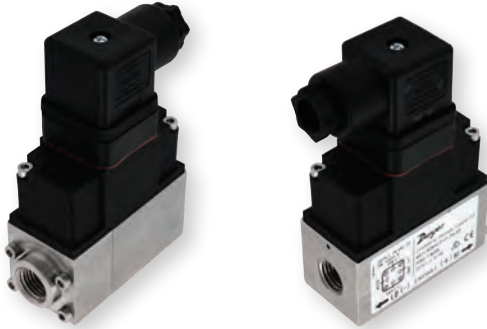

The **Series 629HLP Differential Pressure Transmitters** are suitable for measuring over-pressure, under-pressure, and differential pressure in compatible gases and liquids with 1% accuracy. The 629HLP is suitable for all measuring tasks in commercial, industrial or sanitary applications. Its single sensor design, allows it to measure small increment pressure changes, and converts them to a linear analog output signal from 4-20 mA or 0-10 VDC.

### FEATURES/BENEFITS

- Rugged, versatile, high accuracy device
- For liquid or gas systems requiring precise measurements
- Provide excellent response and reliability
- Suitable for static and dynamic measurements
- Converts pressure changes into 4-20 mA or 0-10 VDC output
- Compact, lightweight, capable to be installed in any arrangement making installation very simple

### APPLICATIONS

- Heat exchangers
- Fan coils/air handlers
- Core testing applications
- Hydraulic systems
- High line pressures/low DP
- Pumps
- Commercial/industrial processes
- Sanitary process

### SPECIFICATIONS

**Service:** Compatible gases or liquids.  
**Wetted Material:** 304 SS.  
**Housing Material:** ABS.  
**Enclosure Rating:** IP65.  
**Accuracy:** ±1% from -5 to 60°C (23 to 140°F).  
**Stability:** ±1% FS/year.  
**Temperature Limits:** Ambient: -10 to 60°C (14 to 122°F); Process: -10 to 80°C (14 to 176°F).  
**Relative Humidity:** 10% to 90% non-condensing.  
**Installation Position:** Not position sensitive.  
**Pressure Limits:** See Pressure Range Limits chart.  
**Burst Pressure:** See Pressure Range Limits chart.  
**Static Pressure Limits:** See Pressure Range Limits chart.  
**Output Signal:** 4-20 mA, 0-10 VDC.  
**Response Time:** 50 ms.  
**Rated Supply Voltage:** 0-10 VDC Output: 12-36 VDC or 12-32 VAC (@ Max load of 2k Ω) 4-20 mA output: 8-36 VDC.  
**Max Loop resistance:** (Supply Voltage – 8 V) / 0.02 for 4-20mA output.  
**Power Consumption:**  $V_{out} = 13$  mA max,  $I_{out} = 24$  mA max.  
**Electrical Connections:** Form A DIN 43650.  
**Process Connections:** 1/4" female NPT, 1/4" female BSPT.  
**Weight:** 1 lb 4 oz (567 g).  
**Approvals:** CE, RCM.

MODEL CHART						
Example	629HLP	-01	-P2	-S1	-FC	629HLP-01-P2-S1-FC
Series	629HLP					Differential pressure transmitter
Range		01				0 to 1 bar
		02				0 to 2.5 bar
		04				0 to 4 bar
		06				0 to 6 bar
		15				0 to 15 psi
		30				0 to 30 psi
		60				0 to 60 psi
		90				0 to 90 psi
Process Connections			P2			1/4" female NPT
			P4			1/4" female BSPT
Output Signal				S1		4-20 mA
				S5		0-10 VDC
Options					FC	Factory calibration
					NIST	NIST certificate

**Note:** Psi ranges available upon request. Contact factory for details.

PRESSURE RANGE LIMITS			
Pressure Range	Maximum Static Pressure (bars)	*Maximum Differential Over Pressure	**Burst Differential Pressure
0 to 1 bar	25 bar	5 bar	8 bar
0 to 2.5 bar	25 bar	5 bar	8 bar
0 to 4 bar	25 bar	12 bar	18 bar
0 to 6 bar	25 bar	12 bar	18 bar
0 to 15 psi	360 psi	70 psi	115 psi
0 to 30 psi	360 psi	70 psi	115 psi
0 to 60 psi	360 psi	174 psi	260 psi
0 to 90 psi	360 psi	174 psi	260 psi

**Note:** \*The differential pressure limit, between high and low ports, that the transmitter can withstand without affecting transmitter performance  
**\*\***Differential pressures between high and low ports that exceed overpressure limits will result in permanent diaphragm deformation, and any pressure higher than the burst pressure limits will rupture the diaphragm.

ACCESSORIES	
Model	Description
A-629HLP-BKT	Mounting bracket kit
BBV-1B	3-Valve block manifold
A-228	12" SS flex hose

# WET/WET DIFFERENTIAL PRESSURE TRANSMITTER

±1.0% Accuracy, NEMA 4 (IP56) Enclosure, 2-Wire

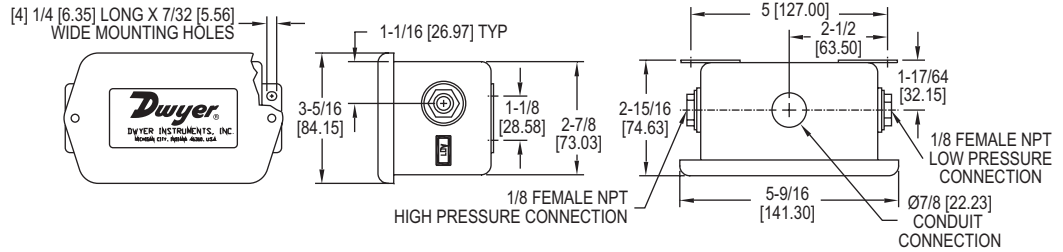

Monitor differential pressure in air/liquid flow systems, HVAC automation, pneumatic systems and process control with the **Series 647 Wet/Wet Differential Pressure Transmitter**. Units are temperature compensated and provide a 4-20 mA output signal which can be interfaced with chart recorders, data loggers and computerized monitoring and control systems.

**FEATURES/BENEFITS**

- Versatile for liquid or gas supports designs requiring more precise measurements in support of application
- Temperature compensated improves performance of device for accurate measurement under different operating environments.
- Output signal provides capability to interface with automation systems to centralize monitoring

**APPLICATIONS**

- Flow
- HVAC automation
- Process control
- Pneumatic systems

MODEL CHART	
Model	Range
647-0	0 to 1 in w.c.
647-1	0 to 3 in w.c.
647-2	0 to 25 in w.c.
647-3	0 to 5 in w.c.
647-4	0 to 10 in w.c.

OPTIONS	
Use order code:	Description
NISTCAL-PT1	NIST traceable calibration certificate

SPECIFICATIONS	
<b>Service:</b>	Compatible gases or liquids on both pressure and reference sides.
<b>Wetted Materials:</b>	Brass, vinyl, glass-filled polyester, silicon, and fluorosilicone.
<b>Accuracy:</b>	±1.0% FS.
<b>Stability:</b>	±1.5% FS output/year.
<b>Temperature Limits:</b>	32 to 122°F (0 to 50°C).
<b>Pressure Limits:</b>	Ranges 1 in w.c. to 5 psi: 20 psi, 15 psi range: 45 psi, 30 psi range: 60 psi.
<b>Thermal Effects:</b>	Zero: ±0.05% FS/°F, Span: ±0.05% rdg/°F.
<b>Power Requirements:</b>	18-30 VDC.
<b>Output Signal:</b>	4-20 mA, 2-wire.
<b>Zero and Span Adjustments:</b>	Adjustable, ±10%.
<b>Loop Resistance:</b>	400Ω @ 18 VDC, 600Ω @ 24 VDC, 1000Ω @ 30 VDC.
<b>Electrical Connection:</b>	Screw terminals, reverse polarity protected.
<b>Process Connections:</b>	Two 1/8" female NPT.
<b>Housing:</b>	Gasketed steel epoxy painted, NEMA 4 (IP56).
<b>Weight:</b>	14 oz (397 g).

# WET/WET DIFFERENTIAL PRESSURE TRANSMITTERS

±0.25% Accuracy, Quick Response, 2-Wire Design

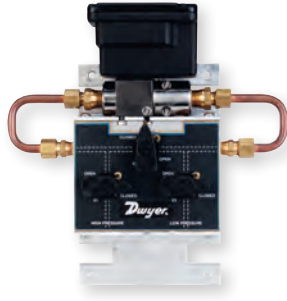

Optional 3-valve manifold assembly

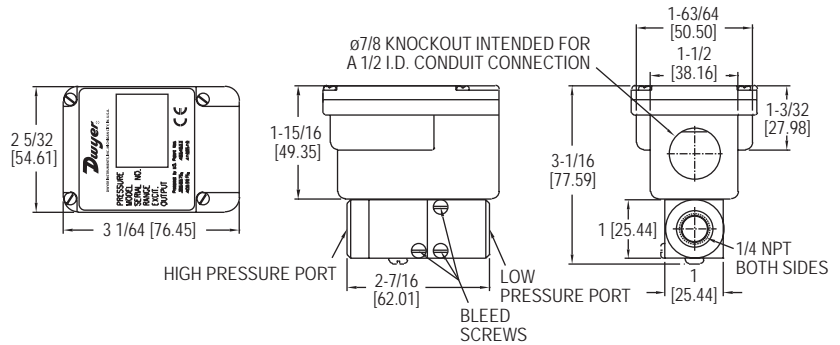

**Series 645 Wet/Wet Differential Pressure Transmitters** are designed for use with compatible gases and liquids which can be applied to both the pressure and reference ports. Quick response capacitance sensor delivers a 4-20 mA output signal proportional to differential pressure with ±.25% accuracy. The Series 645 transmitters are ideal for process control, filter condition monitoring, refrigeration equipment, pump speed control, HVAC equipment, and liquid level measurement. For ease of installation and maintenance, order optional 3-valve manifold assembly. Bleed ports allow for total elimination of air in the line and pressure cavities.

**FEATURES/BENEFITS**

- Versatile, high-accuracy device for liquid or gas supports designs requiring more precise measurements in support of application
- Optional 3-way valve manifold supports simplifying installation or removal of transmitter without interrupting process

**APPLICATIONS**

- Process control
- Refrigeration equipment
- HVAC equipment
- Filter monitoring
- Pump speed control
- Liquid level measurement

MODEL CHART	
Model	Range
645-0	0 to 1 psid
645-1	0 to 2 psid
645-2	0 to 5 psid
645-3	0 to 10 psid
645-4	0 to 25 psid
645-5	0 to 50 psid
645-6	0 to 100 psid
<b>Note:</b> For optional 3-valve manifold assembly, add -3V to end of model number.	

OPTIONS	
Use order code:	Description
NISTCAL-PT1	NIST traceable calibration certificate

SPECIFICATIONS
<b>Service:</b> Compatible gases or liquids on both pressure and reference sides.
<b>Wetted Materials:</b> 17-4 PH stainless steel, 300 Series stainless steel, fluoroelastomer and silicone O-rings and bleed screw seals.
<b>Accuracy:</b> ±0.25% FS (RSS).
<b>Temperature Limits:</b> Operating: 0 to 175°F (-22 to 80°C); Storage: -65 to 260°F (-54 to 126°C).
<b>Pressure Limits:</b> (High side) 1 to 5 psi: 20 x FS, 10 to 25 psi: 10 x FS, 50 psi: 5 x FS, 100 psi: 2.5 x FS; (low side) 2.5 x FS.
<b>Thermal Effects:</b> (includes zero and span) ±0.02% FS/°F, 30 to 150°F (-1 to 65°C).
<b>Power Requirements:</b> 11-30 VDC.
<b>Output Signal:</b> 4-20 mA, 2-wire.
<b>Zero and Span Adjustments:</b> Adjustable, ±1 mA, non-interactive.
<b>Response Time:</b> 30 to 50 ms.
<b>Loop Resistance:</b> 0 to 1000Ω.
<b>Electrical Connection:</b> Barrier strip terminal block with conduit enclosure and .875" (22 mm) diameter conduit opening.
<b>Process Connection:</b> 1/4"-18 female NPT.
<b>Housing:</b> Stainless steel/aluminum, NEMA 4X (IP56).
<b>Weight:</b> 14.4 oz (0.4 kg).
<b>Agency Approvals:</b> CE.
<b>3-VALVE MANIFOLD ASSEMBLY</b>
<b>Manifold:</b> Brass.
<b>Valve Type:</b> 90° on/off.
<b>Process Connection:</b> 1/4"-18 female NPT.

Differential Pressure Transmitters

# DIFFERENTIAL PRESSURE TRANSMITTER

## Selectable Ranges of Uni-Directional or Bi-Directional, Selectable Outputs

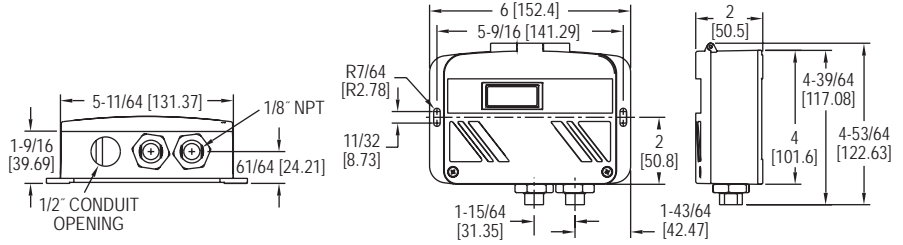

The **Series WWDP Differential Pressure Transmitter** offers everything in one package by having 30 field selectable variations in just 3 models. The WWDP provides field selectable unidirectional and bidirectional pressure ranges, configurable 0-5, 1-5, 0-10 VDC, and 4 to 20 mA output. It also provides an auto-zero capability. The field selectable port swap feature eliminates costly re-plumbing if the unit is improperly installed or if the transmitter is simply replaced. An optional LCD display is available for on-sight indication of line and differential pressure. The all cast aluminum housing is rated NEMA 4 (IP66). These features make the WWDP transmitter an ideal instrument for measuring the flow of various liquids and gases, pressure drop across filters, measurement of liquid level or pressurized vessels, and for use in energy management and process control systems.

### FEATURES/BENEFITS

- Versatile device for liquid or gas supports designs requiring more precise measurements in support of application
- Field selectable port swap eliminates costly re-plumbing if unit is re-installed or replaced
- Uni-directional and bi-directional pressure selection with configurable output provides a single device that can meet broad application needs without having to specify multiple devices
- Optional LCD display provides local status to identify operational conditions
- NEMA 4 rated enclosure provides protection in harsh environments permitting outdoor monitoring or in areas where dust and particulate matter exists

### APPLICATIONS

- Chiller monitoring
- Pressure vessels
- Filter monitoring
- Process control
- Energy management
- Liquid level

### SPECIFICATIONS

**Service:** Gases or liquids compatible with 17-4 PH stainless steel.  
**Accuracy:** All pressure ranges have  $\pm 1\%$  full-scale accuracy except the lowest selectable range of each unit is  $\pm 2\%$  full-scale.  
**Stability:**  $\pm 0.5\%$  per year.  
**Temperature Limits:** Compensated temperature range: 32 to 130°F (0 to 54°C); Operating temperature range: -4 to 185°F (-20 to 85°C).  
**Pressure Limits:** Max working pressure: WWDP-1: 50 psi; WWDP-2: 100 psi; WWDP-3: 250 psi; Proof pressure: 2.2X of full-scale; Burst pressure: 40X of full-scale.  
**Thermal Effect:** 2% FS/100°F (50°C) includes zero and span.  
**Power Requirements:** 12-30 VDC/18-28 VAC (reverse excitation protected). **Note:** 4-20 mA output cannot be powered with AC voltage.  
**Output Signal:** Selectable 0-5, 0-10 and 1-5 VDC; 4-20 mA.  
**Zero & Span:** Digital "re" zero button (should be used when changing ranges). Span can be adjusted by changing between field selectable ranges.  
**Response Time:** 1 to 5 s (selectable).  
**Loop Resistance:** 1000  $\Omega$ .  
**Current Consumption:** VDC power: 0-5, 1-5 VDC output 4 mA (typ); 0-10 VDC output 5 mA (typ); 4-20 mA output 20 mA max. Current consumption will equal the transmitter output in current mode. VAC power: 0-5, 1-5, 0-10 VDC output 40 mA (typ).  
**Electrical Connections:** 1/2" conduit.  
**Process Connections:** 1/8" female NPT internal.  
**Enclosure Rating:** Designed to meet NEMA 4 (IP56).  
**Mounting Orientation:** Vertical; mount the pressure ports down (keeps debris from building up inside the pressure port).  
**Weight:** 1.5 lb (680.4 g).  
**Agency Approvals:** CE.

MODEL CHART		
Model	Description (psid)	Max. Working Pressure (psi)
WWDP-1	Selectable 5, 10, 25, 50	50
WWDP-2	Selectable 10, 20, 50, 100	100
WWDP-3	Selectable 25, 50, 125, 250	250
WWDP-1-LCD	Selectable 5, 10, 25, 50	50
WWDP-2-LCD	Selectable 10, 20, 50, 100	100
WWDP-3-LCD	Selectable 25, 50, 125, 250	250

OPTIONS	
Use order code:	Description
NISTCAL-PT1	NIST traceable calibration certificate



# 2.5" LOW PRESSURE GAGE

3-2-3% Full-Scale Accuracy in a 2.5" Gage

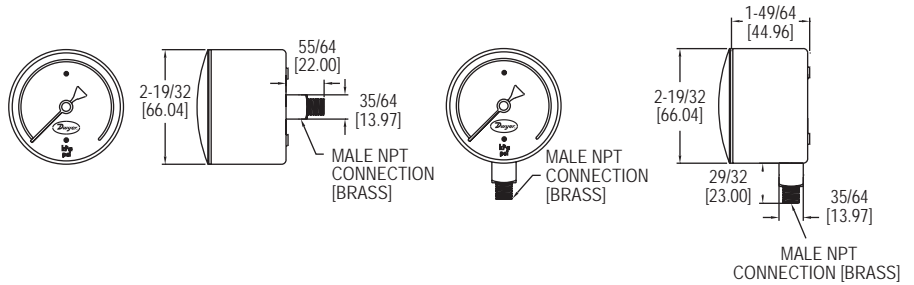

The **Series LPG5 2.5" Low Pressure Gage** offers top of the line performance for pressure applications from 10 in w.c. to 10 psi. The LPG5 gages possess dual scales with 3-2-3% full-scale accuracy on a 2.5" dial. Units are made with a chrome plated steel housing and brass wetted parts. Units can withstand temperatures of -4 to 140°F (-20 to 60°C). This series is meant for the measurement of low pressures of gases and liquids and is ideal for air flow indication, liquid level and draft measurement. Series LPG5 gages are available with either a bottom or back connection option.

**FEATURES/BENEFITS**

- Chrome plated steel housing and brass wetted parts resist ambient for longer service life in harsh environments
- Low pressure gage provides a selection to meet specific applications
- Specified with high ambient and process temperature ratings mean more robust uses and longer service-life
- Good accuracy gage for value-sensitive applications requiring more precise measurement and where vibration is a concern

**APPLICATIONS**

- Air flow indication
- Liquid level
- Draft measurement

MODEL CHART			
Model	Range in w.c. (kPa)	Model	Range psi (kPa)
LPG5-D8022N	0 to 10 (0 to 2.5)	LPG5-D9922N	0 to 5 (0 to 35)
LPG5-D8122N	0 to 15 (0 to 3.75)	LPG5-D0022N	0 to 10 (0 to 70)
LPG5-D8222N	0 to 35 (0 to 8.75)		
LPG5-D8422N	0 to 60 (0 to 15)		
LPG5-D8622N	0 to 100 (0 to 25)		
LPG5-D8822N	0 to 200 (0 to 50)		

**Note:** Change 22N to 42N for back connection option.

OPTIONS	
Use order code:	Description
NISTCAL-PG1	NIST traceable calibration certificate

SPECIFICATIONS
<b>Service:</b> Compatible gases and liquids.
<b>Wetted Materials:</b> Brass connection, bronze tube.
<b>Housing:</b> Chrome plated steel.
<b>Lens:</b> Polycarbonate.
<b>Accuracy:</b> ± 3-2-3% FS.
<b>Pressure Limits:</b> Full-scale range.
<b>Temperature Limits:</b> -4 to 140°F (-20 to 60°C).
<b>Size:</b> 2.5" (63 mm).
<b>Process Connections:</b> 1/4" male NPT.
<b>Weight:</b> 8 oz (227 g).

# 2.5" LOW PRESSURE GAGE

1.5% Full-Scale Accuracy in a 2.5" Gage

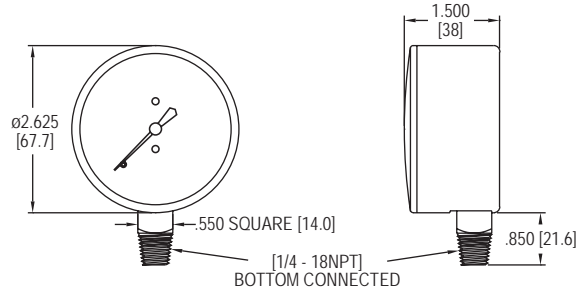

Our **Series LPG4 2.5" Low Pressure Gage** offers top of the line performance and accuracy for pressure and vacuum applications up to and including 160 in w.c. The LPG4 is constructed from a single beryllium-copper diaphragm affixed to a precision-machined brass plate. This innovative design, together with a high-precision, milled-teeth brass movement and nickel-silver pinion and bearing surface, provide the user with a top of the line low pressure instrument.

**FEATURES/BENEFITS**

- Low pressure gage provides a selection to meet specific applications
- Specified with high ambient and process temperature ratings mean more robust uses and longer service-life
- High accuracy gage for applications requiring more precise measurement is a concern

**APPLICATIONS**

- Air flow indication
- Liquid level
- Draft measurement

**SPECIFICATIONS**

**Service:** Compatible gases & liquids.  
**Wetted Materials:** Brass and beryllium copper.  
**Housing:** Drawn steel, black finish.  
**Lens:** Polycarbonate (removable).  
**Accuracy:** ±1.5% FS.  
**Pressure Limit:** 100% of range scale.  
**Temperature Limits:** Process: -40 to 160°F (-40 to 70°C); Ambient: -40 to 140°F (-40 to 60°C).  
**Size:** 2.5" (63 mm).  
**Process Connections:** 1/4" male NPT.  
**Enclosure Rating:** NEMA 3 (IP54).  
**Weight:** 7.3 oz (0.21 kg).

**MODEL CHART**

Model	Range	Model	Range
LPG4-D7122N	-10 to 0 in w.c. (-2.5 to 0 kPa)	LPG4-D8322N	0 to 40 in w.c. (0 to 10 kPa)
LPG4-D7222N	-15 to 0 in w.c. (-4 to 0 kPa)	LPG4-D8422N	0 to 60 in w.c. (0 to 15 kPa)
LPG4-D7322N	-25 to 0 in w.c. (-6 to 0 kPa)	LPG4-D8522N	0 to 80 in w.c. (0 to 20 kPa)
LPG4-D7422N	-40 to 0 in w.c. (-10 to 0 kPa)	LPG4-D8622N	0 to 100 in w.c. (0 to 25 kPa)
LPG4-D7522N	-60 to 0 in w.c. (-15 to 0 kPa)	LPG4-D8722N	0 to 160 in w.c. (0 to 40 kPa)
LPG4-D7622N	-80 to 0 in w.c. (-20 to 0 kPa)	LPG4-D8922N	-4 to 0 to 6 in w.c. (-1 to 0 to 1.5 kPa)
LPG4-D7722N	-100 to 0 in w.c. (-25 to 0 kPa)	LPG4-D9022N	-6 to 0 to 10 in w.c. (-1.5 to 0 to 2.5 kPa)
LPG4-D7822N	-160 to 0 in w.c. (-40 to 0 kPa)	LPG4-D9122N	-8 to 0 to 16 in w.c. (-2 to 0 to 4 kPa)
LPG4-D7922N	-235 to 0 in w.c. (-60 to 0 kPa)	LPG4-D9222N	-16 to 0 to 24 in w.c. (-4 to 0 to 6 kPa)
LPG4-D8022N	0 to 10 in w.c. (0 to 2.5 kPa)	LPG4-D9322N	-24 to 0 to 40 in w.c. (-6 to 0 to 10 kPa)
LPG4-D8122N	0 to 15 in w.c. (0 to 3.75 kPa)	LPG4-D9422N	-30 to 0 to 50 in w.c. (-7.5 to 0 to 12.5 kPa)
LPG4-D8222N	0 to 25 in w.c. (0 to 6 kPa)	LPG4-D9522N	-40 to 0 to 60 in w.c. (-10 to 0 to 15.0 kPa)

**OPTIONS**

Use order code:	Description
NISTCAL-PG1	NIST traceable calibration certificate

# 2.5" INDUSTRIAL PRESSURE GAGES

1.5% FS Accuracy, 316 SS or Brass Wetted Parts, Dual Psi/Bar x100 kPa Scales

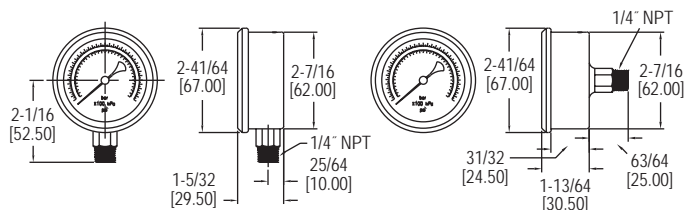
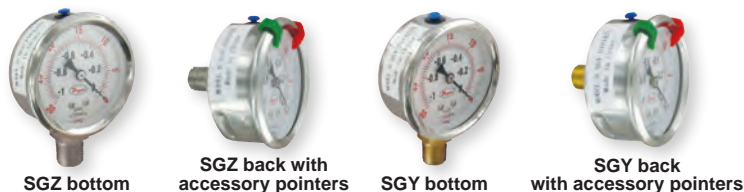

The Series SGY & SGZ 2" Industrial Pressure Gages have dual psi and bar (x100 kPa) scales with  $\pm 1.5\%$  full-scale accuracy. The Series SGZ and SGY gages are designed with 304 SS housings and the SGZ is designed with 316 SS wetted parts for excellent chemical compatibility or SGY brass wetted parts for compatible gases. These gages cover a wide variety of ranges in either bottom or back connection configurations. Series SGZ gages employ an easy-open breather plug on top, which allows liquid filled units to breathe, relieving any built up internal pressures. Plug easily pops open and does not need to be entirely removed or cut like a typical gages' rubber plug grommet.

**FEATURES/BENEFITS**

- Stainless steel housing and wetted parts to resist ambient corrosion for longer service life in harsh environments
- Higher accuracy gage for value-sensitive applications requiring more precise measurement and where vibration is a concern
- Optional sliding pointer clearly mark to make visible critical ranges and high and low points
- Liquid fillable gage with easy open breather plug provides smoother damped movement of pointer
- Back or bottom mounting and compact size provides for mounting with dimensional limitations

**APPLICATIONS**

- Vacuums in pneumatic conveying lines
- Positive pressure in compressed air headers
- Corrosive ambient environments

**ACCESSORIES**

Model	Description
A-445D	U-bracket mounting kit for 2.5" gage
A-499R	Red sliding color pointer
A-499Y	Yellow sliding color pointer
A-499G	Green sliding color pointer

**OPTIONS**

Use order code:	Description
NISTCAL-PG1	NIST traceable calibration certificate

**SPECIFICATIONS**

**Service:** Compatible gases and liquids.  
**Wetted Materials:** SGZ: 316 L SS  
 Tube, 316 SS connector; SGY: Brass connection, bronze tube.  
**Housing:** 304 SS.  
**Lens:** Polycarbonate.  
**Accuracy:**  $\pm 1.5\%$  FS.  
**Pressure Limit:** FS range.

**Temperature Limits:** -4 to 140°F (-20 to 60°C).  
**Size:** 2.5" (63 mm).  
**Process Connections:** 1/4" male NPT.  
**Weight:** 4.9 oz (141 g) bottom, 5.8 oz (164 g) back. Add 3.7 oz (104 g) for glycerin fill.

**MODEL CHART**

Model	Range	Model	Range
SGZ-D10122N	30" Hg to 0	SGY-D10122N	30" Hg to 0
SGZ-D10322N	0 to 30 psi	SGY-D10322N	0 to 30 psi
SGZ-D10422N	0 to 60 psi	SGY-D10422N	0 to 60 psi
SGZ-D10522N	0 to 100 psi	SGY-D10522N	0 to 100 psi
SGZ-D10622N	0 to 160 psi	SGY-D10622N	0 to 160 psi
SGZ-D10722N	0 to 200 psi	SGY-D10722N	0 to 200 psi
SGZ-D11022N	0 to 300 psi	SGY-D11022N	0 to 300 psi
SGZ-D11122N	0 to 500 psi	SGY-D11122N	0 to 500 psi
SGZ-D11222N	0 to 1000 psi	SGY-D11222N	0 to 1000 psi

**Note:** To order with glycerin fill, add -GF to the end of the model. For back connect, change 22N to 42N.

USA: California Proposition 65

⚠WARNING: Cancer and Reproductive Harm - www.P65Warnings.ca.gov

**SERIES 765**

# PROCESS GAGE WITH DAMPENED MOVEMENT

$\pm 0.5\%$  Accuracy, Safety Blow-Out Back

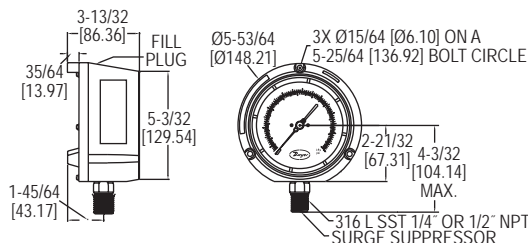

The Series 765 Process Gage with Dampened Movement minimizes effects of vibration without liquid filling. With this dampened movement the 765 gages are ideal for use in any application where high pulsation or vibration exists. The 765 gages offer dual scale range (psi/kPa) with  $\pm 0.5\%$  full-scale accuracy. They are designed with a Phenolic safety-case and have a solid front with a blow-out back. Excellent chemical compatibility is insured with the 316L SS socket and Bourdon tube. A wide offering of ranges are available from full vacuum to 20,000 psi. The 765 process gage comes standard with bottom 1/4" or 1/2" male NPT connections.

**FEATURES/BENEFITS**

- Liquid-free dampened movement minimizes effect of vibration and cost to maintain
- Stainless steel socket and Bourdon tube permit use in chemical applications
- High accuracy gage for applications requiring more precise measurement
- Models that support vacuum to high pressure ranges provide a selection to meet specific applications
- Specified with high ambient and process temperature ratings mean more robust uses and longer service-life

**APPLICATIONS**

- Process applications
- Chemical
- Refinery
- Fertilizer
- Petrochemical
- Power
- Pharmaceutical
- Pulp and paper
- Cement

**OPTIONS**

Use order code:	Description
NISTCAL-PG1	NIST traceable calibration certificate

**SPECIFICATIONS**

**Service:** Compatible gases & liquids.  
**Wetted Materials:** 316L SS socket and Bourdon tube.  
**Housing:** Phenolic plastic with safety blow-out back.  
**Lens:** Polycarbonate.  
**Accuracy:**  $\pm 0.5\%$  ANSI/ASME Grade 2A.  
**Pressure Limit:** 125% FS < 1500 psi, 115% FS for 2000 to 5000 psi, 110% FS > 10,000 psi.

**Temperature Limits:** -40 to 200°F (-40 to 93°C).  
**Size:** 4-1/2" (114.3 mm) dial face.  
**Process Connections:** 1/4" or 1/2" NPT male.  
**Enclosure Rating:** IP65 (NEMA 4).  
**Weight:** 37 oz (1040 g).  
**Agency Approval:** Meets the technical requirements of EU Directive 2011/65/ EU (RoHS II).

**MODEL CHART**

Example Series	765	-01	2N	-FMR	765-012N-FMR
Range	765	01 02 03 04 05 06 07 08 09 10 11			4.5" process gage 30" Hg-0 VAC (-100 to 0 kPa) 0 to 30 psi (0 to 206 kPa) 0 to 60 psi (0 to 410 kPa) 0 to 100 psi (0 to 680 kPa) 0 to 160 psi (0 to 1100 kPa) 0 to 200 psi (0 to 1370 kPa) 0 to 300 psi (0 to 2060 kPa) 0 to 400 psi (0 to 2770 kPa) 0 to 500 psi (0 to 3400 kPa) 0 to 600 psi (0 to 4100 kPa) 0 to 1000 psi (0 to 6800 kPa)
Process Connection			2N 4N		1/4" male NPT 1/2" male NPT
Additional Options				FMR SG45	Flush mounted ring Safety glass lens

For additional ranges contact factory.



**SERIES DPGA/DPGW/DPGWB/DPGAB**

# 0.5% & 1% DIGITAL PRESSURE GAGES

Economic Gage With Selectable Engineering Units, Rubber Boot



DPGA



DPGW



DPGAB



DPGWB

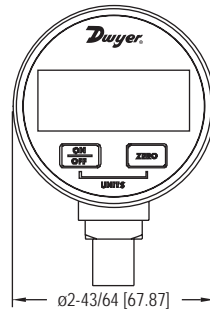

DPGA & DPGW

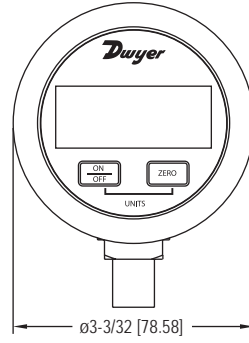
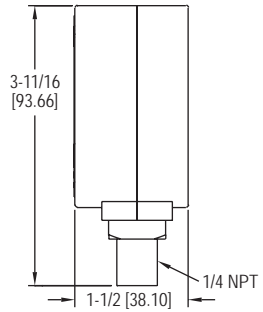

DPGAB & DPGWB

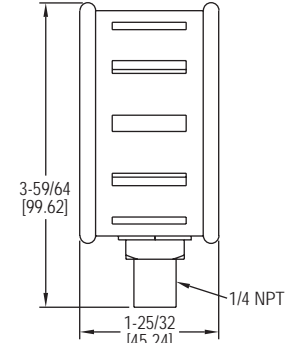

The **Series DPGA 1% Digital Pressure Gage** is the only economic digital pressure gage with selectable engineering units on the market. With its 1% accuracy and digital push-button zero, the DPGA is the perfect choice for digitally monitoring the pressures of air and compatible gases.

The **Series DPGW 1% Digital Pressure Gage** is the only economic digital pressure gage for liquids with the ability to select engineering units on the market. With its 1% accuracy and digital push-button zero, the DPGW is the perfect choice for digitally monitoring the pressures of air and compatible liquids and gases.

The **Series DPGWB/DPGAB 0.5% Digital Pressure Gage** offers full-scale accuracy in a rugged, easy-to-use unit at prices comparable to mechanical gages. The DPGWB stainless steel wetted material makes it suitable for a wide variety of liquids or gases. The gages feature user-selectable units of measure allowing one gage to be used for a variety of pressure scales. The DPGWB/DPGAB come with a protective rubber boot to protect against short drops and rough handling.

**FEATURES/BENEFITS**

- Push-button zero reduce installation and service time
- High accuracy provides exceptional measurement for minimizing costly out of specification conditions
- Selectable unit button provides reading in easily recognizable units
- Well-suited gage for compatible gas (DPGA) or liquid (DPGW) applications specifying simple operation and accuracy

**APPLICATIONS**

- Process applications
- Process start-up
- OEM applications

**SPECIFICATIONS**

**Service:** DPGA & DPGAB: Air and compatible gases; DPGW & DPGWB: Liquids and compatible gases.  
**Wetted Materials:** DPGA & DPGAB: 316L SS, silicone sensor; DPGW & DPGWB: 316L SS.  
**Housing Materials:** ABS plastic.  
**Accuracy:** DPGA & DPGW: ±1.0% FS (includes linearity, hysteresis, repeatability); DPGAB & DPGWB: ±0.5% FS (includes linearity, hysteresis, repeatability).

**Pressure Limits:** 2X pressure range. Vacuum range max. pressure is 30 psig.  
**Temperature Limits:** 30 to 120°F (-1 to 49°C).  
**Thermal Effect:** 0.05% FS/°F.  
**Size:** 2.62" OD x 1.52" deep.  
**Process Connections:** 1/4" male NPT.  
**Display:** 4-digit LCD (.425" H x .234" W digits).  
**Power Requirements:** 9 V alkaline battery, included, user replaceable.  
**Auto Shut-off:** 20 minute auto shut-off.  
**Weight:** 5.6 oz (160 g).

**ACCESSORIES**

Model	Description
A-293	Protective rubber boot

**OPTIONS**

To order add suffix:	Description
-NIST	NIST traceable calibration certificate
Example:	DPGA-04-NIST, DPGAB-04-NIST

MODEL CHART		Range	Pressure Ranges											Resolution
Model	Model		psig	kg/cm <sup>2</sup>	bar	in Hg	ft w.c.	kPa	oz/in <sup>2</sup>	in w.c.	mbar	cm w.c.	mm Hg	
DPGA-00	DPGW-00	30" Hg to 0 (psi)	-14.70	-1.033	-1.013	-29.93	-33.94	-101.4	-235.2	-407.3	-1013	-1034	-761	0.01
DPGA-04	DPGW-04	0 to 5 psi	5.000	.3515	.3447	10.18	11.53	34.47	80.0	138.4	344.7	351.5	258.6	0.002
DPGA-05	DPGW-05	0 to 15 psi	15.00	1.055	1.034	30.54	34.60	103.4	240.0	415.2	1034	1055	776	0.01
DPGA-06	DPGW-06	0 to 30 psi	30.00	2.109	2.068	61.1	69.2	206.8	480.0	830	2068	2109	1551	0.01
DPGA-07	DPGW-07	0 to 50 psi	50.00	3.515	3.447	101.8	115.3	344.7	800	1384	3447	3515	2586	0.02
DPGA-08	DPGW-08	0 to 100 psi	100.0	7.03	6.89	203.6	230.7	689	1600	2768	-	-	-	0.1
DPGA-09	DPGW-09	0 to 200 psi	200.0	14.06	13.79	407.2	461.3	1379	3200	-	-	-	-	0.1
DPGA-10	DPGW-10	0 to 300 psi	300.0	21.09	20.68	611	692	2068	4800	-	-	-	-	0.1
DPGA-11	DPGW-11	0 to 500 psi	500.0	35.15	34.47	1018	1153	3447	-	-	-	-	-	0.2

Compound range available: DPGW-12: 30" Hg-0-100 psi.

MODEL CHART		Range	Pressure Ranges											Resolution
Model	Model		psig	kg/cm <sup>2</sup>	bar	in Hg	ft w.c.	kPa	oz/in <sup>2</sup>	in w.c.	mbar	cm w.c.	mm Hg	
DPGAB-00	DPGWB-00	30" Hg to 0 (psi)	-14.70	-1.033	-1.013	-29.93	-33.94	-101.4	-235.2	-407.3	-1013	-1034	-761	0.01
DPGAB-04	DPGWB-04	0 to 5 psi	5.000	.3515	.3447	10.18	11.53	34.47	80.0	138.4	344.7	351.5	258.6	0.002
DPGAB-05	DPGWB-05	0 to 15 psi	15.00	1.055	1.034	30.54	34.60	103.4	240.0	415.2	1034	1055	776	0.01
DPGAB-06	DPGWB-06	0 to 30 psi	30.00	2.109	2.068	61.1	69.2	206.8	480.0	830	2068	2109	1551	0.01
DPGAB-07	DPGWB-07	0 to 50 psi	50.00	3.515	3.447	101.8	115.3	344.7	800	1384	3447	3515	2586	0.02
DPGAB-08	DPGWB-08	0 to 100 psi	100.0	7.03	6.89	203.6	230.7	689	1600	2768	-	-	-	0.1
DPGAB-09	DPGWB-09	0 to 200 psi	200.0	14.06	13.79	407.2	461.3	1379	3200	-	-	-	-	0.1
DPGAB-10	DPGWB-10	0 to 300 psi	300.0	21.09	20.68	611	692	2068	4800	-	-	-	-	0.1
DPGAB-11	DPGWB-11	0 to 500 psi	500.0	35.15	34.47	1018	1153	3447	-	-	-	-	-	0.2

Compound range available: DPGWB-12: 30" Hg-0-100 psi



# DIGITAL PRESSURE GAGES

±0.25% or ±0.5% FS Accuracy, NEMA 4X (IP66) Aluminum Housing



DPG-000



DPG-100

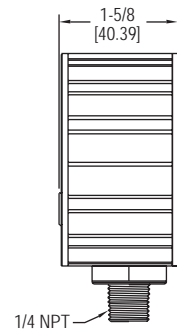
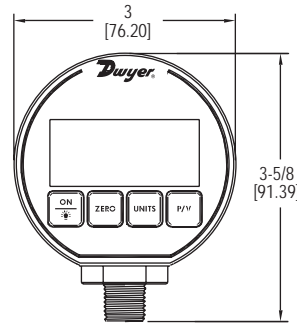

Replace your outdated analog gages with the new **Series DPG Digital Pressure Gages**. The Series DPG has a high ±0.25% or ±0.5% full-scale accuracy. The 4 digit digital display will reduce the potential for errors in readings by eliminating parallax error commonly produced with analog gages. Series DPG is battery powered and has an auto-shut off to conserve battery life. Battery life, on average, will last 2000 hours. A 4 button key pad allows easy access to features without the need to work through complex menus or difficult key combinations. These features include backlight, peak and valley, tare or auto zero and conversion of the pressure units.

**FEATURES/BENEFITS**

- High accuracy provides exceptional measurement minimizing costly out of specification conditions
- Backlit 4-digit display provides clear parallax-free reading reducing potential for errors
- Battery-powered gage with auto-shutoff eliminates wiring and prolongs battery life reducing service calls
- Push-button zero reduce installation and service time

**APPLICATIONS**

- Process applications
- Replacement for legacy analog gages
- OEM applications

**ACCESSORIES**

Model	Description
A-183	Protective rubber boot
A-184	Carrying case



DPG-100 with protective rubber boot



Protective carrying case

**SPECIFICATIONS**

**Service:** Compatible liquids and combustible gases (for FM listing see Agency Approvals below).

**Wetted Materials:** Type 316L SS.

**Housing Materials:** Polycarbonate front & back cover, anodized aluminum extruded housing with recessed grooves, polycarbonate overlay, Buna-N O-rings, 316L SS sensor construction.

**Accuracy:** DPG-000: ±0.5% FS; DPG-100: 0.25% FS; ±1 least significant digit @ 70°F (21°C) (includes linearity, hysteresis, repeatability).

**Pressure Limit:** 2x pressure range for models ≤1000 psi; 5000 psi for 3000 psi range; 7500 psi for 5000 psi range.

**Enclosure Rating:** Designed to meet NEMA 4/4X (IP66).

**Temperature Limits:** 0 to 130°F (-18 to 55°C).

**Thermal Effect:** Between 70 to 130°F is 0.016%/F; Between 32 to 70°F is 0.026%/F; Between 10 to 32°F is 0.09%/F.

**Size:** 3.00" OD x 1.90" deep (max).

**Process Connection:** 1/4" male NPT.

**Weight:** 8.84 oz (275 g).

**Display:** 4 digit (.425" H x .234" W digits).

**Power Requirements:** (2) AAA alkaline batteries, included, user replaceable.

**Battery Life:** 2000 hours typical; Low battery indicator (60 hours in continuous use).

**Auto Shut-Off:** Gage: 60 minute auto shut off. Auto shut-off may be disengaged; Backlight: 2 minute auto shut-off.

**Agency Approvals:** DPG-000: CE; DPG-100: CE, FM approved to be intrinsically safe for Class I, Division I, Groups A, B, C and D, for ranges 0-15 to 0-3000 psi.

**OPTIONS**

To order add suffix:	Description
-NIST	NIST traceable calibration certificate
Example: DPG-002-NIST	

MODEL CHART												
Model ±0.5%	Model ±0.25%	Range psi	Pressure Ranges									
			kg/cm <sup>2</sup>	bar	in Hg	ft w.c.	kPa	oz/in <sup>2</sup>	in w.c.	mbar	cm w.c.	mm Hg
DPG-000*	-	-14.70 to 0	-1.033	-1.013	-29.93	-33.94	-101.4	-235.2	-407.3	-1013	-1034	-760.7
DPG-002*	DPG-102	15.00	1.055	1.034	30.54	34.61	103.4	240	415.2	1034	1055	775.7
DPG-003*	DPG-103	30.00	2.109	2.069	61.08	69.21	206.9	480	830.4	2069	2109	1551
DPG-004*	DPG-104	50.00	3.515	3.448	101.8	115.4	344.8	800	1384	3448	3515	2586
DPG-005*	DPG-105	100.0	7.03	6.895	203.6	230.7	689.5	1600	2768	6895	7031	5172
DPG-006*	DPG-106	200.0	14.06	13.79	407.2	461.4	1379	3200	5536	-	-	-
DPG-007*	DPG-107	300.0	21.09	20.69	610.8	692.1	2069	4800	8304	-	-	-
DPG-008*	DPG-108	500.0	35.15	34.48	1018	1154	3448	8000	-	-	-	-
DPG-009*	DPG-109	1000	70.3	68.98	2036	2307	6895	-	-	-	-	-
DPG-010*	DPG-110	3000	210.9	206.9	6108	6921	-	-	-	-	-	-
DPG-011*	DPG-111*	5000	351.5	344.8	-	-	-	-	-	-	-	-
DPG-020*	-	-14.70 to 15.00	-1.033 to 1.055	-1.013 to 1.034	-29.93 to 30.54	-33.94 to 34.61	-101.4 to 103.4	-235.2 to 240	-407.3 to 415.2	-1013 to 1034	-1034 to 1055	-760.7 to 775.7
DPG-021*	-	-14.70 to 30.00	-1.033 to 2.109	-1.013 to 2.069	-29.93 to 61.08	-33.94 to 69.21	-101.4 to 206.9	-235.2 to 480	-407.3 to 830.4	-1013 to 2069	-1034 to 2109	-760.7 to 1551
DPG-022*	-	-14.70 to 45.00	-1.033 to 3.164	-1.013 to 3.103	-29.93 to 91.63	-33.94 to 103.8	-101.4 to 310.3	-235.2 to 720	-407.3 to 1245	-1013 to 3102	-1034 to 3164	-760.7 to 2327
DPG-023*	-	-14.70 to 60.00	-1.033 to 4.218	-1.013 to 4.137	-29.93 to 122.2	-33.94 to 138.4	-101.4 to 413.7	-235.2 to 960	-407.3 to 1661	-1013 to 4137	-1034 to 4218	-760.7 to 3103
DPG-024*	-	-14.70 to 100.0	-1.033 to 7.03	-1.013 to 6.895	-29.93 to 203.6	-33.94 to 230.7	-101.4 to 689.5	-235.2 to 1600	-407.3 to 2768	-1013 to 6895	-1034 to 7031	-760.7 to 5172

\*Model is not FM approved.

# DIGITAL CALIBRATION PRESSURE GAGE

±0.05% FS Accuracy, 316 SS Wetted Parts

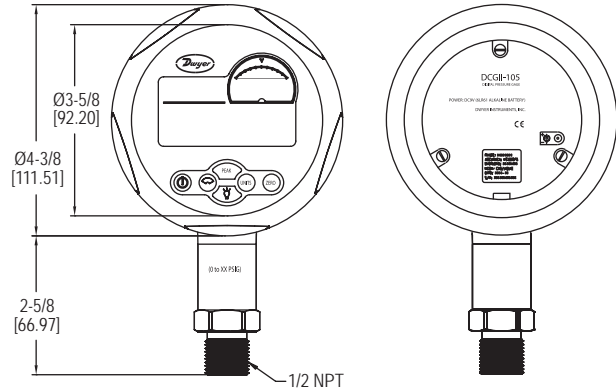

The **Series DCGII Digital Calibration Pressure Gage** offers a complete pressure gage with calibration capabilities. With a precise 0.05% full-scale accuracy and large 5 digit resolution, this gage can be used in critical industrial applications where precision is most important. This versatile gage only requires one 9V battery or power adapter and can operate up to 5,000 working hours. The Series DCGII 0.05% Digital Pressure Gage can display percent of range, pressure swings or alarm set points. This pressure gage comes complete with eleven selectable pressure units, backlight and zeroing capability.

**FEATURES/BENEFITS**

- Highest accuracy provides exceptional measurement for calibration minimizing costly out of specification conditions
- Stainless steel housing resists ambient corrosion for longer service life in harsh environments
- Lightweight and slim, yet large easy to read battery-powered gage make them easy to carry and read
- Specified with high ambient temperature rating means more robust uses and longer service-life
- Indicator can display pressure swings, minimum and maximum peak detection with alarm set points provides a multipurpose tool where critical calibration is needed

**APPLICATIONS**

- Field gage calibration
- Permanent installation
- Burst disc testing
- Torque data logging
- Pressure regulator testing and hydrostatic leak testing

MODEL CHART										
Model	Range (psig)	kPa	mPa	kgf/cm <sup>2</sup>	in H <sub>2</sub> O	in Hg	mm Hg	psi	mbar	bar
DCGII-100	-14.7 to 0	-101.35	-0.1013	-1.0335	-406.90	-29.929	-760.21	-14.700	1013.5	-1.0135
DCGII-101	0 to 15	103.42	0.1034	1.0546	415.20	30.540	775.72	15.000	1034.2	1.0342
DCGII-102	0 to 30	206.84	0.2067	2.1092	830.40	61.080	1551.4	30.000	2068.4	2.0684
DCGII-103	0 to 60	413.69	0.4134	4.2184	1660.8	122.16	3102.9	60.000	4136.9	4.1369
DCGII-104	0 to 100	689.48	0.6890	7.0307	2768.0	203.60	5171.5	100.00	6894.8	6.8948
DCGII-105	0 to 200	1379.0	1.3780	14.061	5536.0	407.20	1034.3	200.00	1379.0	13.790
DCGII-106	0 to 300	2068.4	2.0670	21.092	8304.0	610.80	1551.4	300.00	2068.4	20.684
DCGII-107	0 to 500	3447.4	3.4450	35.153	1384.0	1018.0	2585.7	500.00	3447.4	34.474
DCGII-108	0 to 1000	6894.8	6.8900	70.307	2768.0	2036.0	5171.5	1000.00	6894.8	68.948
DCGII-109	0 to 2000	1379.0	13.780	140.61	5536.0	4072.0		2000.00		137.90

ACCESSORIES	
Model	Description
A-644	9 V DC power adapter
BBV-0N	2-valve block manifold
PCHP-10	Pneumatic calibration pump

SPECIFICATIONS	
<b>Service:</b>	Compatible, non-combustible liquids and gases.
<b>Wetted Materials:</b>	316 SS.
<b>Other Materials:</b>	Housing: Aluminum alloy; Display: Acrylic MR200; Buttons: Silicon gel; Back plate: 304 SS; Back seal: Oil-proof latex.
<b>Accuracy:</b>	0.05% FS; ±1 least significant digit.
<b>Temperature Accuracy:</b>	±1°C.
<b>Pressure Limits:</b>	120% FS.
<b>Temperature Limits:</b>	14 to 122°F (-10 to 50°C).
<b>Compensated Limits:</b>	32 to 122°F (0 to 50°C).
<b>Process Connection:</b>	1/2" male NPT.
<b>Display:</b>	5-digit LCD with blue backlight.
<b>Power Requirements:</b>	9 V alkaline battery, not included, or power adapter accessory.
<b>Battery Life:</b>	Up to 10,000 hours (600 working hours @ default 3 times/s).
<b>Auto Shut-Off:</b>	Backlight: On/off, 10 s, 20 s, 30 s.
<b>Weight:</b>	1.28 lb (0.58 kg).
<b>Agency Approvals:</b>	CE.

OPTIONS	
Use order code:	Description
NISTCAL-PG2	NIST traceable pressure calibration certificate

# DIGITAL PRESSURE GAGE

## 3-in-1: Gage, Transmitter and Switch

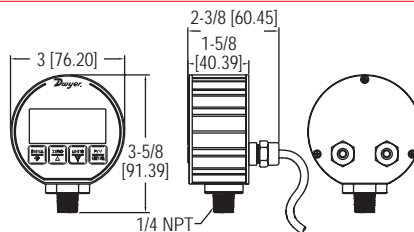

The **Series DPG-200 Digital Pressure Gage** has a precise  $\pm 0.25\%$  full-scale accuracy. The 4 digit digital display will reduce the potential for errors in readings by eliminating parallax error commonly produced with analog gages. The DPG-200 is packaged in a durable extruded aluminum case designed to meet NEMA 4X (IP66). The unit is powered by 12-24 VDC/VAC and contains two alarm set points along with a 4-20 mA process output. A four-button keypad allows easy access to features. These features include backlight, peak and valley, auto zero and conversion of the pressure units. Pressure ranges also in mbar, kg/cm<sup>2</sup>, oz/in<sup>2</sup>, in Hg, mm Hg, ft w.c. and ft sw for various models.

**FEATURES/BENEFITS**

- High accuracy provides exceptional measurement minimizing costly out of specification conditions
- Backlit 4-digit display provides clear parallax-free reading reducing potential for errors
- Durable aluminum case to meet NEMA 4X (IP66) requirements supports use in harsh or outdoor environments
- Push-button zero reduce installation and service time

**APPLICATIONS**

- Process control
- Compressor control

Model	Range (psig)	Pressure Ranges				
		bar	ft w.c.	kPa	in w.c.	cm w.c.
DPG-200	-14.70-0	-1.013	-33.94	-101.4	-407.3	-1034
DPG-202	15.00	1.034	34.61	103.4	415.2	1055
DPG-203	30.00	2.069	69.21	206.9	830.4	2109
DPG-204	50.00	3.448	115.4	344.8	1384	3515
DPG-205	100.0	6.895	230.7	689.5	2768	7031
DPG-206	200.0	13.79	461.4	1379	5536	-
DPG-207	300.0	20.69	692.1	2069	8304	-
DPG-208	500.0	34.48	1154	3448	-	-
DPG-209	1000	68.98	2307	6895	-	-
DPG-210	3000	206.9	6921	-	-	-
DPG-211	5000	344.8	-	-	-	-

Compound range available: DPG-220 range: 30" Hg-0-15 psi.

**SPECIFICATIONS**

**DIGITAL GAGE SPECIFICATIONS**  
**Service:** Liquids and non-combustible compatible gases.  
**Wetted Materials:** Type 316L SS.  
**Enclosure:** Black polycarbonate front & back cover, anodized aluminum extruded enclosure with recessed grooves, polycarbonate overlay, Buna-N O-rings, 316L SS sensor construction.  
**Accuracy:** 0.25% FS  $\pm 1$  least significant digit (includes linearity, hysteresis, repeatability).  
**Pressure Limit:** 2x pressure range for models  $\leq 1000$  psi; 5000 psi for 3000 psi range; 7500 psi for 5000 psi range.  
**Temperature Limits:** 32 to 158°F (0 to 70°C).  
**Process Connection:** 1/4" male NPT.  
**Display:** 4 digit (425" H x .234" W digits).  
**Size:** 3.00" OD x 1.90" deep (not including cables).  
**Weight:** 8.84 oz (275 g).

**SWITCH SPECIFICATIONS**  
**Switch Type:** 2 SPDT form C contacts.  
**Electrical Rating:** 0.5 A @ 125 VAC resistive, 1 A @ 24 VDC.  
**Relay Differential:** 1 least significant digit.  
**Electrical Connections:** 3 ft (.91 m) cable.  
**Mounting Orientation:** Mount in any position.  
**Set Point Adjustment:** Via menu.

**TRANSMITTER SPECIFICATIONS**  
**Temperature Limits:** 0 to 158°F (0 to 70°C).  
**Thermal Effect:** Between 70 to 158°F = 0.016%/°F. Between 0 to 70°F = 0.026%/°F.  
**Power Requirements:** 12-24 VAC  $\pm 20\%$  50 to 400 Hz, 12-24 VDC  $\pm 20\%$ .  
**Output Signal:** 4-20 mA.  
**Loop Resistance:** 600  $\Omega$  max.  
**Power Consumption:** 0.8 W max.  
**Electrical Connections:** 3 ft (.91 m) cable.  
**Enclosure Rating:** Designed to meet NEMA 4X (IP66).

**OPTIONS**

Use order code:	Description
-NIST	NIST traceable calibration certificate

**SERIES DSGT**

# DIGITAL INDICATING TRANSMITTER

## $\pm 0.25\%$ Full-Scale Accuracy

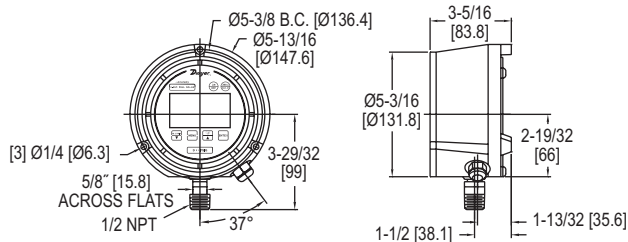

The **Series DSGT Digital Indicating Transmitter** is a versatile multi-function process gage that features an excellent 0.25% full-scale accuracy. This all-in-one digital gage package is designed to reduce installation costs, instrument cost, and save space where an application requires a gage, transmitter, and switches. The Series DSGT gage comes standard with a loop-powered 4-20 mA transmitter. The Series DSGT gage is enclosed in a durable fiberglass reinforced thermoplastic case that is designed to meet NEMA 4 IP56 requirements. The gage features a menu-driven display for easy customization. User selectable features include 12 engineering units of measure, password protected calibration and disable functions, as well as an adjustable bar graph and update/dampening rates.

**FEATURES/BENEFITS**

- All-in-one digital gage package is designed to reduce installation costs, instrument cost, and save space where an application requires a gage, transmitter, and switches
- Durable fiberglass reinforced thermoplastic case to meet NEMA 4 (IP56) requirements supports use in harsh environments
- Password protected calibration and disable functions helps to insure no errors by untrained personnel

**APPLICATIONS**

- Process
- Outdoor
- Compressor
- OEM

MODEL CHART							
Model	Range (psig)	Model	Range (psig)	Model	Range (psig)	Model	Range (psig)
DSGT-101-C0S	30" Hg-0 to 15	DSGT-106-C0S	0 to 100	DSGT-109-C0S	0 to 300	DSGT-116-C0S	0 to 5000
DSGT-102-C0S	30" Hg-0 to 30	DSGT-107-C0S	0 to 160	DSGT-110-C0S	0 to 600	DSGT-117-C0S	0 to 8000
DSGT-104-C0S	0 to 30	DSGT-108-C0S	0 to 200	DSGT-112-C0S	0 to 1000	DSGT-118-C0S	0 to 10000
DSGT-105-C0S	0 to 60						

**SPECIFICATIONS**

**GAGE SPECIFICATIONS**  
**Service:** Compatible, non-combustible liquids & gases.  
**Wetted Materials:** 17 to 4 stainless steel sensor, 316 SS socket.  
**Housing Materials:** Fiberglass reinforced thermoplastic case.  
**Accuracy:** 0.25% FS (includes linearity, hysteresis, repeatability).  
**Pressure Limit:** 2 x FS range.  
**Process Connection:** 1/2" male NPT.  
**Display:** 5 digit (0.88" high).

**TRANSMITTER SPECIFICATIONS**  
**Power Requirements:** 12-36 VDC (loop powered).  
**Memory Back Up Supply:** (2) C alkaline batteries, installed functional, user replaceable.  
**Output Signal:** 4-20 mA.  
**Response Time:** 100 ms.  
**Temperature Limits:** 14 to 140°F (-10 to 60°C).  
**Thermal Effects:** 0.04% FS/°F.  
**Electrical Connections:** 3 ft flying leads.  
**Loop Resistance:** DC; 0 to 1090  $\Omega$  max.  
**Set Point Adjustments:** Adjustable through menu selections.  
**Weight:** 1.45 lb (.66 kg).

**OPTIONS**

Use order code:	Description
NISTCAL-PT1	NIST traceable calibration certificate

# DIGITAL PRESSURE TRANSMITTER WITH SWITCHES

Two Solid State Switches, LED Display

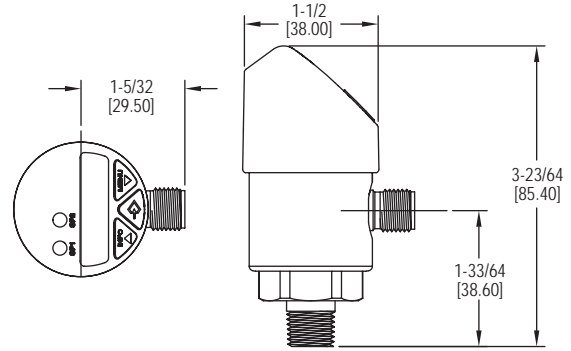

The **Series DPT Digital Pressure Transmitter with Switches** combines a large, 14-segment LED display with two programmable solid state switches into one compact unit. A unique, 3-way rotating design allows the DPT to meet specific installation requirements without any retrofitting. The display and electrical connection can be rotated independently to maximize visibility while still orienting the electrical connection in the best position for the cable connector. Large, ergonomically designed push-buttons allow for quick/easy programming and thin-film piezoresistive sensor technology guarantees long-term reliability and stability.

**FEATURES/BENEFITS**

- Compact size, lightweight, and high accuracy supports multiple installation methods to support application need and footprint
- Rotating display and electrical connection to maximize visibility while orienting the electrical connection in the best position for the cable connector

**APPLICATIONS**

- Calibration
- Hydraulics and pneumatics
- Machine tools
- Compressors and pumps
- Machine building

**SPECIFICATIONS**

**Service:** Compatible gases, liquids or vapors.  
**Wetted Materials:** Pressure connection: 316 L SS; Pressure sensor: 316 L SS (13-8 PH for ranges above 150 psi).  
**Housing:** 316 L lower body, heat and chemical resistant fiberglass reinforced plastic (PBT) plastic head, TPE-E keyboard, PC display window.  
**Accuracy:** 1.0% FS (includes non-linearity, hysteresis, zero point).  
**Pressure Limit:** See table.  
**Temperature Limits:** 32 to 176°F (0 to 80°C).  
**Process Connections:** 1/4" male NPT.  
**Display:** Red LED 4-digit (0.35" H digits).  
**Weight:** 7 oz (0.2 kg).

**SWITCH SPECIFICATIONS**

**Switch Type:** PNP.  
**Electrical Rating:** 250 mA.  
**Electrical Connections:** M 12x1, 5-pin.  
**Mounting Orientation:** Mount in any position.

**TRANSMITTER SPECIFICATIONS**

**Temperature Limits:** 32 to 176°F (0 to 80°C).  
**Thermal Effect:** 0.2% FS / 10k.  
**Power Requirements:** 15-35 VDC.  
**Output Signal:** DPT-A: 4-20 mA; DPT-V: 0-10 VDC.  
**Loop Resistance:** DPT-A: ≤ 0.5k; DPT-V: > 10k.  
**Power Consumption:** ≤ 100 mA.  
**Electrical Connections:** M 12x1, 5-pin.  
**Enclosure Rating:** IP67.

MODEL CHART								
0-10 VDC	4-20 mA	Range (psig)	Maximum Pressure (psig)	Burst Pressure (psig)	Pressure Ranges			
Model	Model				bar	MPa	kPa	kg/cm <sup>2</sup>
DPT-V00	DPT-A00	-14.5 to 0	30	75	1.034	.1034	103.4	1.055
DPT-V01	DPT-A01	0 to 15	30	75	1.034	.1034	103.4	1.055
DPT-V02	DPT-A02	0 to 25	60	150	1.724	.1724	172.4	1.758
DPT-V03	DPT-A03	0 to 30	60	150	2.068	.2068	206.8	2.109
DPT-V04	DPT-A04	0 to 50	100	250	3.447	.3447	344.7	3.515
DPT-V05	DPT-A05	0 to 100	200	500	6.895	.6895	689.5	7.031
DPT-V06	DPT-A06	0 to 160	290	500	11.03	1.103	1103	11.25
DPT-V07	DPT-A07	0 to 200	400	1500	13.79	1.378	1378	14.06
DPT-V08	DPT-A08	0 to 300	600	1500	20.68	2.068	2068	21.09
DPT-V09	DPT-A09	0 to 500	1000	2500	34.47	3.447	3447	35.15
DPT-V10	DPT-A10	0 to 1000	1740	7975	68.95	6.895	6895	70.31

OPTIONS	
Use order code:	Description
NISTCAL-PT1	NIST traceable calibration certificate

ACCESSORIES	
Model	Description
A-195	6' (2 m) shielded cable with 5 pin female M-12 connections



# ELECTRONIC PRESSURE CONTROLLER

## 2 Switches, Indicating Gage, and Transmitter in One Package

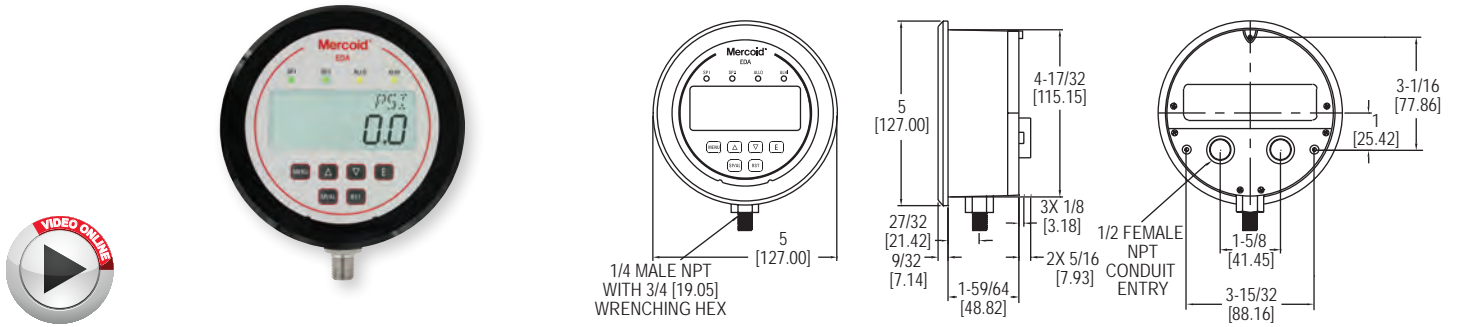

**Series EDA Electronic Pressure Controller** is an extremely versatile compact package that can replace a separate gage, two switches, and a transmitter in a system saving money, installation time, and panel space. The EDA incorporates two SPDT relays that have the on and off points fully adjustable over the range for control or alarm use. Front face has LED indicators for switch status and a large backlight two-line display showing process value and indication units. Programming is easy with simple menu structure, two-line display, and external programming buttons. Weatherproof housing is ideal for a wide variety of applications with panel mount, flush mount, or pipe mount ability. Features include zero set, adjustable dampening, menu lock out, peak and valley indication, removable terminal blocks, adjustable time delay, and scalable transmitter output.

**FEATURES/BENEFITS**

- Versatile compact package that can replace a separate gage, two switches, and a transmitter in a system saving money, installation time, and panel space
- Fully programmable to meet simple or complex application needs
- Test mode function simulates input over the range without pressuring to easily test switches and transmitter output function
- Fail-safe relay output choices in case of sensor failure, over pressure, high temperature limit, low temperature limit, or keypad short
- Selectable alternation of set points between the relays for even wear on duplex pump applications
- Weatherproof housing is ideal for a wide variety of applications with panel mount, flush mount, or pipe mount ability

**APPLICATIONS**

- Process control
- Compressor control
- Filter status
- Duct or building static pressure
- Damper and fan control

**SPECIFICATIONS**

**Service:** Compatible liquids and gases.  
**Wetted Materials:** 316L SS.  
**Housing:** Polycarbonate.  
**Accuracy:** ±1% of FS including linearity, hysteresis, and repeatability (indicator and transmitter).  
**Stability:** < ±2% of FS per year.  
**Pressure Limits:** 1.5 x range.  
**Temperature Limits:** Ambient: 20 to 140°F (-6.6 to 60°C); Process: 0 to 176°F (-18 to 80°C).  
**Compensated Temperature Limits:** 32 to 122°F (0 to 50°C).  
**Thermal Effect:** ±0.05% of FS/°F.  
**Display:** 4-digit backlight LCD (digits: 0.60"H x 0.33" W).  
**Power Requirements:** 12-30 VDC/AC.  
**Power Consumption:** 2.5 watts.  
**Electrical Connections:** Removable terminal blocks with two 1/2" female NPT conduit connections.  
**Enclosure Rating:** Meets NEMA 4X (IP66).  
**Warm Up Time:** <10 s.  
**Mounting Orientation:** Any position.  
**Weight:** 1.18 lb (535 g).  
**Agency Approvals:** CE, UL.

**SWITCH SPECIFICATIONS**  
**Switch Type:** 2 SPDT relays.  
**Electrical Rating:** 5 A @ 120/240VAC, 1 A @ 30 VDC.  
**Repeatability:** ±1% of FS (switching only).  
**Set Points:** Adjustable 0-100% of FS.  
**Switch Indication:** External LED for each relay on the front panel.  
**Switch Reset:** Manual or automatic.

**TRANSMITTER SPECIFICATIONS**  
**Output Signal:** 4-20 mA, 1-6 VDC, 1-5 VDC, 0-5 VDC, or 0-10 VDC (direct or reverse output selection).  
**Minimum Excitation:** 14 VDC.  
**Zero and Span Adjustments:** Menu scalable within the range.

MODEL CHART								
Example	EDA	W	-N1	E1	-02	T0	-AT	EDAW-N1E1-02T0-AT
Series	EDA							Electronic pressure controller
Housing		W						Weatherproof
Process Connection			N1					1/4" NPT male bottom
Electrical Connection				E1				Two 1/2" female NPT conduit connections
Range					02			0-20 psi (1.379 bar)
					03			0-60 psi (4.14 bar)
					04			0-100 psi (6.89 bar)
					05			0-150 psi (10.34 bar)
					06			0-300 psi (20.68 bar)
					07			0-600 psi (41.4 bar)
					08			0-1000 psi (68.9 bar)
					09			0-1500 psi (103.4 bar)
					10			0-3000 psi (206.8 bar)
Transmitter Output						T0		None
						T1		4-20 mA
						T2		1-5 VDC
						T3		0-5 VDC
						T4		1-6 VDC
						T5		0-10 VDC
Options						AT		Aluminum adhesive tag
						NIST		NIST certificate
						23444		Oxygen cleaning

ACCESSORIES	
Model	Description
A-590	1/2" conduit plug, watertight
A-EDA-BRK	Flush mount bracket for EDA, bracket is then surface mounted, steel with gray hammertone epoxy finish



A-EDA-BRK with EDA installed

Single Pressure Gages/Switches/Transmitters, Digital

# BOURDON TUBE PRESSURE SWITCH

Pressure Ranges to 8000 psi (551.6 bar)

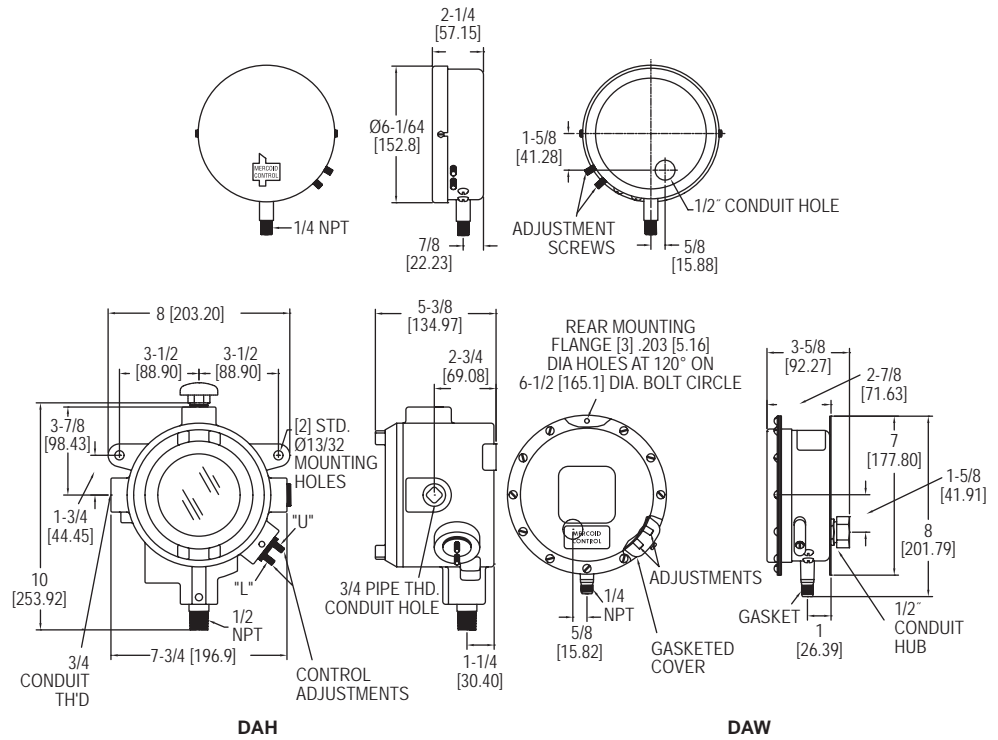
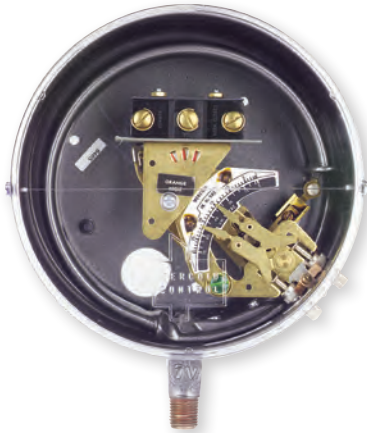

Customers tell us that the **Series DA/DS Bourdon Tube Pressure Switch** is the best pressure switch made. The Mercoid DA/DS Series is one of the world's broadest lines of pressure switches. The DA/DS Series has extremely high sensitivity and great repeatability. The DA Models are equipped with two external adjustments, one for setting high pressure operating point, the other for setting low pressure operating point. Deadband, the difference between high and low setpoints, is adjustable over the full-scale. The DS Models are equipped with a single external adjustment for setting operating point only. For mercury-free switches, choose between the snap action switch or hermetically sealed snap action switch. Hermetically sealed mercury switch also available.

## FEATURES/BENEFITS

- Visible calibrated dial provides an easy and fast check without having to open device causing dangerous conditions to operators
- On/off indication (except hermetically sealed snap switch models) gives operator clear indication of state of switched equipment that could be located in another location
- Adjustable or fixed deadband supports control applications by reducing equipment wear-out by unnecessary recycling
- External switch set point adjustment reduces set-up time
- Pressure ranges of full vacuum to 8000 psig gives application designers the ability to specify standard equipment, simplifying install and training, and reducing servicing costs
- UL listed, CSA approved, many models FM approved to support rigorous process applications and regulations
- General purpose, weatherproof or explosion-proof enclosures for a variety of indoor or outdoor environments meeting the needs of multiple applications and uses

## APPLICATIONS

- Compressors
- Mechanical HVAC or process equipment
- Pump control

## SPECIFICATIONS

**Wetted Materials:** Brass, 403 SS, or 316 SS.

**Temperature Limit:** 180°F (82°C).

**Pressure Limit:** Maximum pressure of the operating range.

**Enclosure Rating:** General purpose, weatherproof or explosion-proof.

**Repeatability:** ±1% of full operating range, ±1.5% on DS-7300 models.

**Switch Type:** SPST mercury switch, SPDT mercury switch, SPDT snap switch, or SPDT hermetically sealed snap switch. Other circuit types available.

**Electrical Rating:** See model charts.

**Electrical Connections:** Screw terminal.

**Conduit Connection:** General purpose: 1/2" hole for conduit hub; Weatherproof: 1/2" conduit hub; Explosion-proof: 3/4" female NPT.

**Process Connection:** General purpose and weatherproof: 1/4" male NPT, 1/2" male NPT on ranges 15S and 16S; Explosion-proof: 1/2" male NPT and 1/4" female NPT.

**Mounting Orientation:** Vertical.

**Set Point Adjustment:** Thumbscrew.

**Weight:** General purpose: 4 lb (1.8 kg); Weatherproof: 6 lb (2.7 kg); Explosion-proof: 8 lb (3.5 kg).

**Deadband:** See model chart.

**Agency Approvals:** CSA, FM, UL (mercury switch units are not CE approved) (Consult factory for FM approved models).



SERIES DA/DS | MERCOID® BY DWYER



PRESSURE

# BOURDON TUBE PRESSURE SWITCH

Pressure Ranges to 8000 psi (551.6 bar)

MODEL CHART - D SERIES PRESSURE SWITCH WITH SNAP ACTION SWITCH AND GENERAL PURPOSE ENCLOSURE							
Bourdon Tube Material	Adjustable Operating Range (psig)	Adjustable Deadband SPDT: 10 A @ 120/240 VAC		Fixed Deadband SPDT: 15 A @ 120/240 AC		Hermetically Sealed, Fixed Deadband SPDT: 5 A @ 120/240 VAC, 5 A res. @ 30 VDC	
		Minimum Deadband (psig)	Model	Fixed	Model	Fixed	Model
Brass	0 to 30" Hg VAC	13.5" Hg	DA-7031-153-2	3" Hg	DS-7231-153-2	5" Hg	DS-7331-153-2
Brass	10" Hg VAC to 12	6	DA-7031-153-3	1.5	DS-7231-153-3	3	DS-7331-153-3
Brass	25" Hg VAC to 50	12	DA-7031-153-27	2.5	DS-7231-153-27	3.75	DS-7331-153-27
Brass	1/8 to 15	6	DA-7031-153-1	1.5	DS-7231-153-1	3	DS-7331-153-1
Brass	1/8 to 20	6	DA-7031-153-3A	1.5	DS-7231-153-3A	3	DS-7331-153-3A
Brass	1 to 35	7.5	DA-7031-153-4	1.5	DS-7231-153-4	3	DS-7331-153-4
Brass	2 to 60	9	DA-7031-153-5	2	DS-7231-153-5	3	DS-7331-153-5
Brass	5 to 100	13.5	DA-7031-153-6	2.5	DS-7231-153-6	3.75	DS-7331-153-6
Brass	5 to 150	24	DA-7031-153-7	3	DS-7231-153-7	5.25	DS-7331-153-7
Brass	10 to 200	24	DA-7031-153-8	4	DS-7231-153-8	6.75	DS-7331-153-8
Brass	10 to 300	37.5	DA-7031-153-9	5	DS-7231-153-9	9	DS-7331-153-9
403 stainless steel	30" Hg VAC to 60	18	DA-7021-153-25S	3.5	DS-7221-153-25S	5.25	DS-7321-153-25S
403 stainless steel	30" Hg VAC to 75	22.5	DA-7021-153-26S		DS-7221-153-26S	5.25	DS-7321-153-26S
403 stainless steel	2 to 60	13.5	DA-7021-153-5S	3	DS-7221-153-5S	4.5	DS-7321-153-5S
403 stainless steel	5 to 100	19.5	DA-7021-153-6S	3.5	DS-7221-153-6S	5.25	DS-7321-153-6S
403 stainless steel	10 to 200	22.5	DA-7021-153-8S	4	DS-7221-153-8S	7.125	DS-7321-153-8S
403 stainless steel	10 to 300	28.5	DA-7021-153-9S	6	DS-7221-153-9S	10.5	DS-7321-153-9S
403 stainless steel	40 to 350	30	DA-7021-153-9AS	6	DS-7221-153-9AS	10.5	DS-7321-153-9AS
403 stainless steel	25 to 600	67.5	DA-7021-153-10S	10	DS-7221-153-10S	18	DS-7321-153-10S
403 stainless steel	50 to 1000	142.5	DA-7021-153-11S	20	DS-7221-153-11S	33	DS-7321-153-11S
403 stainless steel	100 to 1500	195	DA-7021-153-12S	30	DS-7221-153-12S	52.5	DS-7321-153-12S
403 stainless steel	300 to 2500	390	DA-7021-153-13S	60	DS-7221-153-13S	90	DS-7321-153-13S
403 stainless steel	500 to 5000	1350	DA-7021-153-15S	200	DS-7221-153-15S	300	DS-7321-153-15S
403 stainless steel	800 to 8000	2250	DA-7021-153-16S	500	DS-7221-153-16S	5.25	DS-7341-153-26E
316 stainless steel	30" Hg VAC to 75	15	DA-7041-153-26E	3.5	DS-7241-153-26E	6	DS-7341-153-23E
316 stainless steel	5 to 75	12	DA-7041-153-23E	4	DS-7241-153-23E	5.25	DS-7341-153-6E
316 stainless steel	10 to 100	15	DA-7041-153-6E	3.5	DS-7241-153-6E	6.75	DS-7341-153-24E
316 stainless steel	10 to 150	16.5	DA-7041-153-24E	4	DS-7241-153-24E	12	DS-7341-153-9E
316 stainless steel	10 to 300	42	DA-7041-153-9E	8	DS-7241-153-9E	18	DS-7341-153-21E
316 stainless steel	30 to 400	78	DA-7041-153-21E	10	DS-7241-153-21E	37.5	DS-7341-153-22E
316 stainless steel	75 to 800	180	DA-7041-153-22E	25	DS-7241-153-22E	52.5	DS-7341-153-11E
316 stainless steel	100 to 1000	285	DA-7041-153-11E	35	DS-7241-153-11E	112.5	DS-7341-153-13E
316 stainless steel	200 to 2500	600	DA-7041-153-13E	75	DS-7241-153-13E		

MODEL CHART - D SERIES PRESSURE SWITCH WITH MERCURY SWITCH AND GENERAL PURPOSE ENCLOSURE

Bourdon Tube Material	Adjustable Operating Range (psig)	Adjustable Deadband			
		Minimum Deadband (psig)	SPDT 4 A @ 120 V, 2 A @ 240 V AC/DC	SPST Open on Increase 10 A @ 120 V, 5 A @ 240 V AC/DC	SPST Close on Increase 10 A @ 120 V, 5 A @ 240 V AC/DC
Brass	30" to 0 Hg VAC	2" Hg	DA-31-153-2	DA-31-2-2	DA-31-3-2
Brass	10" Hg VAC to 12	1	DA-31-153-3	DA-31-2-3	DA-31-3-3
Brass	25" Hg VAC to 50	3.5	DA-31-153-27	DA-31-2-27	DA-31-3-27
Brass	1/8 to 15	1	DA-31-153-1	DA-31-2-1	DA-31-3-1
Brass	1/8 to 20	1	DA-31-153-3A	DA-31-2-3A	DA-31-3-3A
Brass	1 to 35	1.75	DA-31-153-4	DA-31-2-4	DA-31-3-4
Brass	2 to 60	3	DA-31-153-5	DA-31-2-5	DA-31-3-5
Brass	5 to 100	3.75	DA-31-153-6	DA-31-2-6	DA-31-3-6
Brass	5 to 150	6	DA-31-153-7	DA-31-2-7	DA-31-3-7
Brass	10 to 200	8	DA-31-153-8	DA-31-2-8	DA-31-3-8
Brass	10 to 300	12	DA-31-153-9	DA-31-2-9	DA-31-3-9
403 stainless steel	30" Hg VAC to 60	6	DA-21-153-25S	DA-21-2-25S	DA-21-3-25S
403 stainless steel	30" Hg VAC to 75	8	DA-21-153-26S	DA-21-2-26S	DA-21-3-26S
403 stainless steel	2 to 60	4	DA-21-153-5S	DA-21-2-5S	DA-21-3-5S
403 stainless steel	5 to 100	6	DA-21-153-6S	DA-21-2-6S	DA-21-3-6S
403 stainless steel	10 to 200	8	DA-21-153-8S	DA-21-2-8S	DA-21-3-8S
403 stainless steel	10 to 300	14	DA-21-153-9S	DA-21-2-9S	DA-21-3-9S
403 stainless steel	40 to 350	14	DA-21-153-9AS	DA-21-2-9AS	DA-21-3-9AS
403 stainless steel	25 to 600	25	DA-21-153-10S	DA-21-2-10S	DA-21-3-10S
403 stainless steel	50 to 1000	60	DA-21-153-11S	DA-21-2-11S	DA-21-3-11S
403 stainless steel	100 to 1500	90	DA-21-153-12S	DA-21-2-12S	DA-21-3-12S
403 stainless steel	300 to 2500	150	DA-21-153-13S	DA-21-2-13S	DA-21-3-13S
403 stainless steel	500 to 5000	450	DA-21-153-15S	DA-21-2-15S	DA-21-3-15S
403 stainless steel	800 to 8000	750	DA-21-153-16S	DA-21-2-16S	DA-21-3-16S
316 stainless steel	30" Hg VAC to 75	7	DA-41-153-26E	DA-41-2-26E	DA-41-3-26E
316 stainless steel	5 to 75	3	DA-41-153-23E	DA-41-2-23E	DA-41-3-23E
316 stainless steel	10 to 100	7	DA-41-153-6E	DA-41-2-6E	DA-41-3-6E
316 stainless steel	10 to 150	6	DA-41-153-24E	DA-41-2-24E	DA-41-3-24E
316 stainless steel	10 to 300	18	DA-41-153-9E	DA-41-2-9E	DA-41-3-9E
316 stainless steel	30 to 400	30	DA-41-153-21E	DA-41-2-21E	DA-41-3-21E
316 stainless steel	75 to 800	75	DA-41-153-22E	DA-41-2-22E	DA-41-3-22E
316 stainless steel	100 to 1000	100	DA-41-153-11E	DA-41-2-11E	DA-41-3-11E
316 stainless steel	200 to 2500	210	DA-41-153-13E	DA-41-2-13E	DA-41-3-13E

**OPTIONS**

**Weatherproof Enclosure - Series DAW**  
**Note:** To order, add "W" to model number after DA or DS, change 1 to 3.  
**Example:** DAW-33-153-7

**Explosion-Proof Enclosure - Series DAH**  
 Suitable for Class I, Groups C and D; NEMA 7; Class II, Groups E, F, G; Class III NEMA 9 and 9A, Division 1.  
**Note:** To order, add "H" to model number after DA or DS. **Example:** DAH-31-153-7

**FM Approved**  
 For general purpose and explosion-proof models see agency approvals.  
**Note:** To order, add "F" to model number after DA, DS, DAH or DSH.  
**Examples:** DAF-31-153-7 or DAHF-31-153-7

**Other Options (Consult Factory)**  
 DPDT switches or other switch types, fixed deadband mercury switch units for low deadband applications, manual reset operation, two-stage operation, acetal bushed movement for applications with high amounts of vibration and/or pulsation, fungus proofing, siphon, diaphragm seals, mounting flange and remote connection.

Single Pressure Switches

USA: California Proposition 65  
 ⚠️WARNING: Cancer and Reproductive Harm - www.P65Warnings.ca.gov



SERIES SA1100 | MERCOID® BY DWYER



# DIAPHRAGM OPERATED PRESSURE SWITCH

Visible Set point, Adjustable Deadband, Hermetically Sealed Snap Switch, Weatherproof and Explosion-Proof

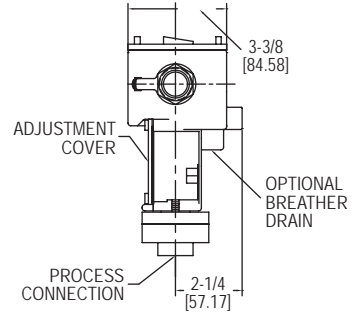
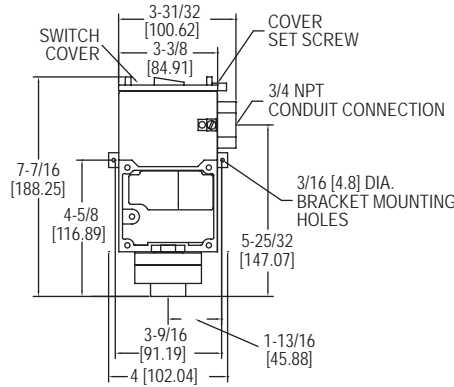

The Series SA1100 Diaphragm Operated Pressure Switch is weatherproof and explosion-proof in one economical enclosure. Extremely rugged construction assures excellent reliability in chemical, petroleum and industrial plants. New design also provides burst pressure protection to 3000 psi (206 bar). The rolling diaphragm design maintains a constant effective area to minimize friction. This results in a minimum deadband as low as 5% of full-scale. Since many applications require higher deadbands, the SA1100 includes a separate adjustment of this when necessary. A pump being used to control liquid level in a tank would be a typical situation where this feature would be important. Both set point and deadband adjustments are protected, yet clearly visible behind a clear polycarbonate window and are fully isolated from the electrical components for additional safety. A 7/16" open-end wrench is the only tool required to change settings. Terminal blocks are provided for switch wiring connections and both internal and external ground screws are included. Standard housing is weatherproof to NEMA standards 1 through 4X and 13; explosion-proof to NEMA 7, Class I, Groups B, C & D; NEMA 9, Class II, Groups E, F & G. Optional construction adds drain to meet NEMA 3R IP54.

### FEATURES/BENEFITS

- Explosion-proof and weatherproof housing provides device protection for outdoor use or harsh environment operation
- Burst pressure protection prevents device failure where high-pressure surges may damage device costing down-time and repair/replacement
- Adjustable deadband reduces equipment cycling and potential failure
- Visible set point and deadband adjustments provide an easy and fast check without having to open device causing dangerous conditions to operators

### APPLICATIONS

- Chemical, petroleum, food and drug processing industries
- Used indoor, outdoor or in explosion-proof area
- Pump control

### SPECIFICATIONS

**Wetted Materials:** See pressure chamber and diaphragm material in model chart.  
**\*Temperature Limits:** -30 to 180°F (-35 to 82°C) standard; ATEX compliant at Ambient Temperature: -4 to 167°F (-20 to 75°C); Process Temperature: -4 to 167°F (-20 to 75°C).  
**Pressure Limit:** 1200 psig (82.6 bar).  
**\*Enclosure Rating:** Weatherproof and Explosion-proof. Listed with UL and CSA for Class I, Groups B, C and D; Class II Groups E, F, and G. ATEX Compliant **CE** 0344 **Ex** II 2 G EEx d IIC T6 Process Temperature 75°C. Weatherproof UL Rated Type 4. Meets NEMA 4X (IP66).  
**Switch Type:** SPDT or DPDT snap switch.  
**Electrical Rating:** See model chart.  
**Electrical Connections:** Screw terminal.  
**Conduit Connection:** 3/4" female NPT.  
**Process Connection:** 1/2" female NPT.  
**Mounting Orientation:** Within 20° of vertical.  
**Set Point Adjustment:** Internal 7/16" hex nuts.  
**Weight:** 3.5 lb (1.6 kg).  
**Deadband:** See deadband chart.  
**\*Agency Approvals:** ATEX, CE, CSA, UL.  
 \*Options that do not have ATEX.

### SWITCH DEADBAND CHART

Range Number	Adjustable Operating Range		Approximate Minimum Deadband				Approximate Maximum Deadband	
	psig	bar	psig	bar	psig	bar	psig	bar
11	10-150	0.7-10	4.0	0.28	7.5	0.52	75	5.2
12	20-250	1.4-17.2	5.0	0.35	12.5	0.86	150	10
13	30-500	2.0-34	12	0.83	45	3.1	300	21

### MODEL CHART

Example	SA11	13	E	-A	4	-K	2		SA1113E-A4-K2
<b>Construction</b>	SA11								Series designator, weatherproof NEMA 4X, explosion-proof NEMA 7, 9
<b>Adjustable Pressure Ranges</b>		11							Adjustable range 10 to 150 psig (0.7-10 bar)
		12							Adjustable range 20 to 250 psig (1.4-17.2 bar)
		13							Adjustable range 30 to 500 psig (2.0-34.0 bar)
<b>Circuit (Switch) Options</b>			E						Snap action switch rated 15 A @ 125/250/480 VAC, 1/8 HP @ 125 VAC, 1/4 HP @ 250 VAC, 1/2 A @ 125 VDC resistive, 1/4 A @ 250 VDC resistive
			HS						Hermetically sealed snap action switch rated 5 A @ 125/250 VAC, 5 A resistive @ 30 VDC*
			HG						Hermetically sealed snap action switch with gold contacts rated 1A @ 125 VAC, 1 A resistive @ 30 VDC*
<b>Pressure Chamber Material (Wetted)</b>				A					Aluminum
<b>Diaphragm Material (Wetted)</b>				S					316 SS
					4				Buna-N diaphragm and O-ring
					5				Fluorocarbon diaphragm and O-ring
<b>Circuit (Switch) Type</b>						K			SPDT
						L			DPDT (not available with HS or HG switch options)
<b>Process Connection</b>							2		1/2 inch female NPT
<b>*Options</b>								AT	ATEX certified construction
								DRAIN	Housing with drain - allows condensate to be drained from inside enclosure (meets NEMA 3R instead of 4X)

\*Options that do not have ATEX

Examples: SA1111E-A4-K2; SA1111E-S5-K2



# WEATHERPROOF DIAPHRAGM OPERATED PRESSURE SWITCH

Visible Set point, Fixed Deadband, Pressure Ranges to 1400 psi

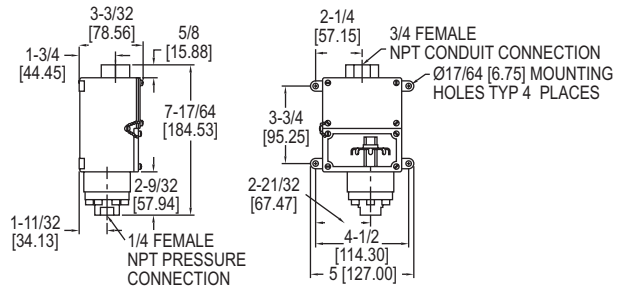

With extremely rugged construction the **Series 1000W Weatherproof Diaphragm Operated Pressure Switch** provides excellent reliability in chemical, petroleum and industrial plants. Bellville spring movement permits mounting of control in any position and helps prevent contact chatter. New design also provides high over-pressure protection. Weatherproof housing is standard.

**FEATURES/BENEFITS**

- Weatherproof housing is ideal for a wide variety of applications where dust or water is present
- Spring movement design provides for control in any mounting position and prevents contact chatter reducing false or inconsistent switching

**APPLICATIONS**

- Chemical, petroleum, food and drug processing industries
- Process and Industrial applications

**SPECIFICATIONS**

**Wetted Materials:** See pressure chamber and diaphragm material in model chart.  
**Temperature Limits:** -30 to 170°F (-35 to 77°C).  
**Pressure Limit:** 3000 psig (206.8 bar).  
**Enclosure Rating:** Weatherproof, meets NEMA 4X (IP66).  
**Switch Type:** SPDT snap switch.  
**Electrical Rating:** 15 A @ 125/250 VAC resistive.

**Electrical Connections:** Screw type.  
**Conduit Connection:** 3/4" female NPT.  
**Process Connection:** 1/4" female NPT.  
**Mounting Orientation:** Any position.  
**Set Point Adjustment:** Internal thumbwheel.  
**Weight:** 3 lb (1.4 kg).  
**Deadband:** See model chart.  
**Agency Approvals:** CE, UL.

**MODEL CHART**

Aluminum Pressure Chamber Polyamide Diaph. Model	316 SS Pressure Chamber FEP Diaph. Model	Adjustable Operating Range psig (bar)	Approx.* Deadband (Fixed) psig (bar)
1003W-A1-D	1003W-B3-D	5 to 40 (.48 to 2.8)	2 (.14)
1004W-A1-D	1004W-B3-D	10 to 70 (.69 to 4.8)	4 (.28)
1005W-A1-D	1005W-B3-D	25 to 200 (1.7 to 13.8)	8 (.55)
1006W-A1-D	1006W-B3-D	50 to 350 (3.5 to 24.1)	15 (1.0)
1007W-A1-D	1007W-B3-D	75 to 550 (5.2 to 37.9)	30 (2.1)
1008W-A1-D	1008W-B3-D	100 to 900 (6.9 to 62.1)	50 (3.5)
1009W-A1-D	1009W-B3-D	200 to 1400 (13.8 to 96.5)	75 (5.2)

\*Deadband 10-15% larger when using 316 SS diaphragm.  
**Note:** To order, change A1 to B2 for 316 SS diaphragm and pressure chamber.  
**Example:** 1003W-B2-D. Values shown are for mid-scale.

# EXPLOSION-PROOF DIAPHRAGM OPERATED PRESSURE SWITCH

Visible Set point, Fixed Deadband, Pressure Ranges to 1400 psi

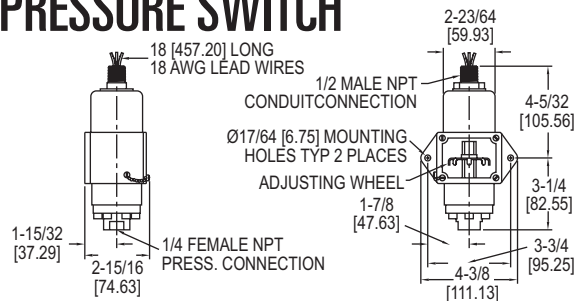

The **Series 1000E Explosion-Proof Diaphragm Operated Pressure Switch** has the same rugged construction as used in Series 1000W plus explosion-proof design are combined in this new unit. UL listed for Class I, Groups A, B, C & D; Class II, Groups E, F & G. Bellville spring movement permits mounting of control in any position and helps prevent contact chatter. High over-pressure protection and vibration resistance are also featured.

**FEATURES/BENEFITS**

- Weatherproof housing is ideal for a wide variety of applications where dust or water is present
- Spring movement design provides for control in any mounting position and prevents contact chatter reducing false or inconsistent switching
- UL listed to support rigorous process applications and regulations

**APPLICATIONS**

- Chemical, petroleum, food and drug processing industries
- Process and industrial applications

**SPECIFICATIONS**

**Wetted Materials:** See pressure chamber and diaphragm material in model chart.  
**Temperature Limits:** -30 to 170°F (-35 to 77°C).  
**Pressure Limit:** 3000 psig (206.8 bar).  
**Enclosure Rating:** Explosion-proof, UL listed for Class I, Groups A, B, C and D; Class II, Groups E, F, and G.  
**Switch Type:** SPDT snap switch. Hermetically sealed optional.  
**Electrical Rating:** 15 A @ 125/250/480 VAC res., 0.5 A @ 125 VDC, 0.25 A @ 250 VDC.

**Wiring Connections:** 18 AWG, 18" (460 mm) color-coded leads: N.O. (yellow), N.C. (black), and common (red).  
**Conduit Connection:** 1/2" male NPT.  
**Process Connection:** 1/4" female NPT.  
**Mounting Orientation:** Any position.  
**Set Point Adjustment:** Internal thumbwheel.  
**Weight:** 3 lb (1.4 kg).  
**Deadband:** See model chart.  
**Agency Approvals:** CE, UL.

**MODEL CHART**

Aluminum Pressure Chamber Polyamide Diaph. Model	316 SS Pressure Chamber FEP Diaph. Model	Adjustable Operating Range psig (bar)	Approx.* Deadband (Fixed) psig (bar)
1003E-A1-J	1003E-B3-J	5 to 40 (.48 to 2.8)	2.5 (.17)
1004E-A1-J	1004E-B3-J	10 to 70 (.69 to 4.8)	5 (.34)
1005E-A1-J	1005E-B3-J	25 to 200 (1.7 to 13.8)	10 (.69)
1006E-A1-J	1006E-B3-J	50 to 350 (3.5 to 24.1)	18 (1.2)
1007E-A1-J	1007E-B3-J	75 to 550 (5.2 to 37.9)	36 (2.5)
1008E-A1-J	1008E-B3-J	100 to 900 (6.9 to 62.1)	60 (4.1)
1009E-A1-J	1009E-B3-J	200 to 1400 (13.8 to 96.5)	90 (6.2)

\*Deadband 10-15% larger when using 316 SS diaphragm.  
**Note:** To order, change A1 to B2 for 316 SS diaphragm and pressure chamber.  
**Example:** 1003E-B2-J. Values shown are for mid-scale.



SERIES H2 | W. E. ANDERSON™ BY DWYER



# DUAL-ACTION EXPLOSION-PROOF PRESSURE SWITCH

Explosion-proof and Weatherproof Enclosure

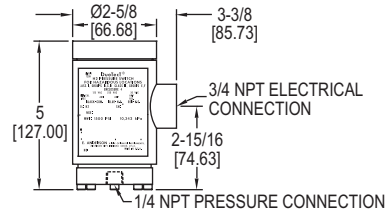

Explosion-Proof, UL & CSA Listed for Class I, Groups B, C & D and Class II, Groups E, F & G. The **Series H2 Dual-Action Explosion-Proof Pressure Switch** is designed for sequencing two different actions as pressure of a liquid or gas increases or decreases. The design consists of two concentric pistons operated by a single diaphragm with one pressure chamber. Each piston actuates a separate switch independent of the other. The switches may be adjusted to operate together, at opposite ends of the range or at two intermediate set points. The threaded top is removed to field adjust or service switches without disturbing electrical or pressure connections. The Duotect® switch is explosion-proof and weatherproof. It can be mounted in any position and is not affected by vibration.

### FEATURES/BENEFITS

- Explosion-proof and weather-proof housing provides device protection for outdoor use or harsh environment operation
- UL listed, CSA approved to support rigorous process applications and regulations
- Independent piston action design for either gas or liquid allows switches to active together or independently based on settings
- Mounting in any position and not affected by vibration provides reliable switching for equipment

### APPLICATIONS

- Mechanical HVAC or process equipment
- Chemical, petroleum, food and drug processing industries
- Process and Industrial applications

### SPECIFICATIONS

**Wetted Materials:** 316 SS chamber with FEP diaphragm and Buna-N O-ring standard. Fluoroelastomer or EPDM O-ring optional.  
**Temperature Limit:** 275°F (135°C). CSA approved: -20 to 90°C (-4 to 184°F).  
**Pressure Limit:** 1500 psig (103 bar).  
**Enclosure Rating:** UL listed explosion-proof, Class I, Groups B, C, and D. Class II Groups E, F, and G. Meets NEMA 4X (IP66). CSA optional. Class I, Groups B, C & D. Class II, Groups E, F, & G -20°C ≤ Tamb ≤ 75°C T6 [optional -20°C ≤ Tamb ≤ 40°C T5] Type 4.

**Switch Type:** Two SPDT snap switches.  
**Electrical Rating:** 5 A @ 125/250 VAC, 5 A res., 3 A ind. @ 30 VDC. Gold contacts optional.  
**Electrical Connections:** 18 AWG, 18" (460 mm) long.  
**Conduit Connection:** 3/4" female NPT.  
**Process Connection:** 1/4" female NPT.  
**Mounting Orientation:** Any position.  
**Set Point Adjustment:** Internal nut.  
**Weight:** 2 lb (.9 kg).  
**Deadband:** Approximately 10% of range.  
**Agency Approvals:** CSA, UL.

### MODEL CHART

Model	Low Range psig (bar)	High Range psig (bar)
H2S-1	3 to 40 (0.21 to 2.76)	5 to 75 (0.35 to 5.17)
H2S-2	25 to 250 (1.72 to 17.2)	30 to 400 (2.07 to 27.6)
H2S-3	100 to 1000 (6.89 to 68.9)	150 to 1500 (10.3 to 103)

## SERIES A1F | MERCROID® BY DWYER

# OEM PRESSURE SWITCH

Field Adjustable with Weather-Proof Enclosure

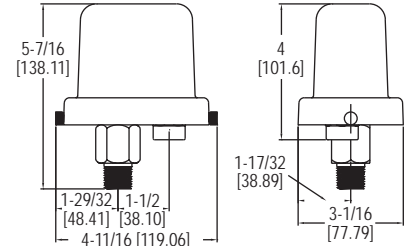
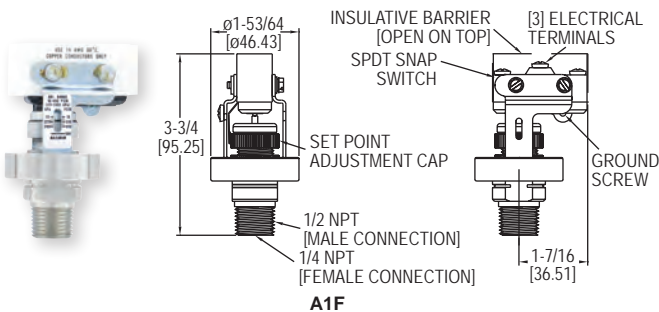

Low cost and precision made, the **Series A1F Low Cost OEM Pressure Switch** is ideal for OEM industrial applications. Wetted materials of 316 SS and fluorocarbon ensure great chemical compatibility with a wide range of process media. The open case style is perfect for panel mounting applications like pump skids. Weatherproof enclosure is available in polycarbonate offering a low cost weatherproof switch. Superior 15 A contact allows direct control of motors or pumps without the use of external relays, a true cost savings. Features include a convenient indicating scale for quick and easy field adjustment.

### FEATURES/BENEFITS

- 15 A contact allows direct control reducing costs and reliability by having to introduce additional contacts and relays
- Case style allows use for panel mounting application with optional weather-proof enclosure for use in outdoor environments
- Field adjustable reduces installation time bring application on-line faster
- Wetted material provides support for wider range of process media

### APPLICATIONS

- OEM
- Compressors
- Motor control
- Process equipment
- Pump control

### SPECIFICATIONS

**Service:** Compatible liquids and gases.  
**Wetted Materials:** Pressure chamber: 316 SS; Diaphragm: Fluorocarbon.  
**Temperature Limit:** -40 to 175°F (-40 to 80°C).  
**Pressure Limits:** 500 psig (34 bar).  
**Enclosure Rating:** No rating for open construction. Installed properly within an optional weatherproof enclosure meets NEMA 4X (IP66) standards.  
**Switch Type:** SPDT snap switch.  
**Electrical Rating:** 15 A @ 120/240/480 VAC; 1/8 HP @ 125 VAC; 1/4 HP @ 250 VAC.  
**Electrical Connection:** Screw terminals.  
**Process Connection:** 1/4" female NPT and 1/2" male NPT.  
**Mounting Orientation:** Within 20° of vertical.  
**Set Point Adjustment:** Knurled screw cap with indicating scale.  
**Deadband:** Fixed. See deadband chart.  
**Weight:** 10.5 oz (297 g).  
**Agency Approvals:** cULus.

### MODEL CHART

Model	Range psig (bar)	Deadband at Min. Range psig (bar)	Deadband at Max. Range psig (bar)
A1F-O-SS-1-1	2 to 15 (0.14 to 1.03)	2 (0.14)	3 (0.21)
A1F-O-SS-1-2	4 to 75 (0.28 to 5.17)	4 (0.27)	15 (1.0)
A1F-O-SS-1-3	8 to 225 (0.55 to 15.5)	8 (0.55)	25 (1.7)
A1F-O-SS-1-4	16 to 450 (1.1 to 31.0)	15 (1.0)	50 (3.5)

**Note:** Optional enclosure factory installed. To order, change O to PC.

**Example:** A1F-PC-SS-1-1

# ECONOMICAL PRESSURE SWITCH

Vacuum and Compound Ranges Available, Adjustable Set Point

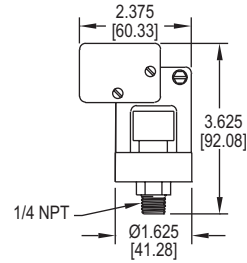

The **Series A1PS/A1VS Economical Pressure Switch** is designed with a 15 Amp SPDT switch for direct control of pumps and motors. Available in pressure, vacuum, or compound ranges, the switches offer a field adjustable set point. Easily adjust the switch by aligning the top of the self locking adjusting nut with the desired setting indicated on the adjacent range scale. Connection is 1/4" male NPT for quick installation and can be mounted in any position.

**FEATURES/BENEFITS**

- 15 A contact allows direct control reducing costs and reliability by having to introduce additional contacts and relays
- Field adjustable reduces installation time bring application on-line faster

**APPLICATIONS**

- OEM
- Compressors
- Process equipment
- Motor control
- Pump control

**SPECIFICATIONS**

<p><b>Service:</b> Compatible liquids or gases.  <b>Wetted Materials:</b> Diaphragm: Buna-N; Body with fitting: Zinc alloy, chromate finish.  <b>Temperature Limits:</b> -31 to 185°F (-35 to 85°C).  <b>Pressure Limits:</b> 600 psig.  <b>Vacuum Limits:</b> 29.9" Hg (vacuum and compound models only).  <b>Switch Type:</b> SPDT snap action.</p>	<p><b>Electrical Ratings:</b> 15 A (resistive) @ 250 VAC, 1/2 HP @ 250 VAC.  <b>Electrical Connections:</b> Three screw terminals.  <b>Process Connection:</b> 1/4" male NPT.  <b>Set Point:</b> Field adjustable via knurled screw cap.  <b>Cycling:</b> Not to exceed 1 Hz.  <b>Sensor Element:</b> Diaphragm.  <b>Weight:</b> 7.4 oz (209 g).  <b>Agency Approvals:</b> UL.</p>
---	--

**MODEL CHART**

Model	Set Point Range (kPa)	Repeatability (kPa)	Deadband (approx.) (kPa)	Model	Set Point Range (kPa)	Repeatability (kPa)	Deadband (approx.) (kPa)
A1PS-14	1.5 to 3.5 psi (10 to 24)	±0.15 psi (1)	0.5 to 1.7 psi (3 to 11)	A1VS-14	6-28" Hg (-20 to -94)	±1.2" Hg (-4)	3-14" Hg (-10 to -47)
A1PS-24	3 to 40 psi (21 to 276)	±1.0 psi (7)	2 to 5 psi (14 to 34)	A1VS-24	28" Hg to 3.5 psig (-94 to 24)	±1.2" Hg (-4), ±0.15 psi (1)	6" Hg - 1.5 psi (-20 to 10)
A1PS-34	30 to 150 psi (207 to 1034)	±5.0 psi (34)	5 to 30 psi (34 to 207)				
A1PS-44	100 to 500 psi (689 to 3445)	±20.0 psi (138)	30 to 120 psi (207 to 827)				

**SERIES APS/AVS**



# ADJUSTABLE PRESSURE SWITCH

Vacuum and Pressure Ranges, 5 A Switch, Compact Size

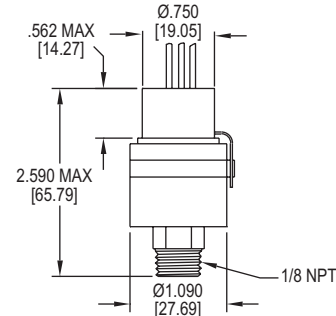

Miniature **Series APS/AVS Adjustable Pressure Switch** offers reliable switching for pressure/vacuum alarm, shutdown or control. The units are readily adjustable throughout their range using the locking adjusting ring and indicating pointer. The body is constructed of stainless steel for durability in harsh environments. Switches include 12" (30 cm) wire leads sealed with epoxy for additional protection.

**FEATURES/BENEFITS**

- Field adjustable with simple indicating pointer reduces installation time bring application on-line faster
- Stainless steel construction provides a durable solution in harsh environments

**APPLICATIONS**

- OEM
- Process equipment
- Compressors
- Motor control
- Pump control

**SPECIFICATIONS**

<p><b>Service:</b> Compatible liquids or gases.  <b>Wetted Materials:</b> Capsule: 17-7 PH SS; Fitting: 303 SS.  <b>Temperature Limits:</b> -65 to 225°F (-54 to 107°C), a set point change of up to 2% when used below -10°F (-23°C) or above 125°F (52°C).  <b>Pressure/Vacuum Limits:</b> 150% of range.  <b>Switch Type:</b> SPDT snap action.</p>	<p><b>Electrical Ratings:</b> 5 A @ 250 VAC, 3 A @ 28 VDC.  <b>Electrical Connections:</b> 3-wire, 20 AWG insulated with PVC, 12" (30 cm) length.  <b>Process Connection:</b> 1/8" male NPT.  <b>Set Point:</b> Field adjustable.  <b>Cycling:</b> Not to exceed 20 CPM.  <b>Sensor Element:</b> Capsule.  <b>Weight:</b> 3 oz (85 g).  <b>Agency Approvals:</b> UR.</p>
--	--

**MODEL CHART**

Model	Set Point Range psi (bar)		Repeatability psi (bar)	Deadband psi (bar)	Model	Set Point Range Hg (cm Hg) VAC		Repeatability Hg (cm Hg)
	Decreasing	Increasing				Decreasing	Increasing	
APS-150	0.8 to 28.5 (.06 to 2.0)	1.6 to 30.0 (.11 to 2.1)	±0.6 (.04)	0.8 to 1.3 (.06 to .09)	AVS-150	1.6 to 27.1 (4.1 to 68.6)	2.7 to 28.2 (6.9 to 71.6)	±1.2 (3.1)
APS-250	2.0 to 48.0 (.14 to 3.3)	3.0 to 50.0 (.21 to 3.5)	±1.0 (0.7)	1 to 1.7 (.07 to .12)	AVS-250	4.0 to 24.8 (10.2 to 63.0)	5.1 to 28.2 (13.0 to 71.6)	±2.0 (5.1)
APS-350	3.0 to 96.5 (.21 to 6.7)	4.5 to 100 (.31 to 6.9)	±2.0 (.14)	1.6 to 4 (.11 to .28)	AVS-350	6.0 to 21.5 (15.2 to 54.6)	8.4 to 28.2 (21.3 to 71.6)	±4.0 (10.2)
APS-450	7.5 to 242 (.52 to 16.7)	9.7 to 250 (.67 to 17.2)	±5.0 (.35)	2.5 to 9 (.17 to .62)				
APS-550	15.0 to 485 (1.0 to 33.4)	20.0 to 500 (1.4 to 34.5)	±10.0 (.69)	5 to 22 (.35 to 1.5)				



SERIES A6 | MERCOID® BY DWYER

# DURABLE PRESSURE SWITCHES

Designed for Extended Duty, Simple and Reliable

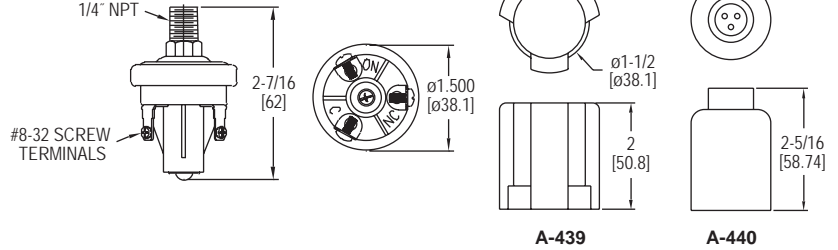

**Series A6 Durable Pressure Switches** have been specifically designed to stand up to extended duty applications. These switches are constructed with a polyimide film diaphragm and are compatible with a variety of fluids. For ease of installation, the switches come with a 1/4" male NPT process connection and can be mounted in any orientation. The Series A6 pressure switches are compact and have great set point integrity, and feature simple, easy set point field adjustment.

**FEATURES/BENEFITS**

- High switch cycle means long life for extended duty applications
- Mounting in any position and feature simple makes a reliable switching for equipment and OEM applications

**APPLICATIONS**

- OEM
- Process equipment
- Process applications

MODEL CHART		
Model	Set Point Range psi (bar)	
	NC	NO
A6-153221	0.5 to 1 (0.03 to 0.07)	1.1 to 3.1 (0.08 to 0.21)
A6-253221	1.1 to 3 (0.08 to 0.21)	2.27 to 6.05 (0.16 to 0.42)
A6-353221	3.1 to 7 (0.21 to 0.48)	4.22 to 10.75 (0.29 to 0.74)
A6-453221	8 to 13 (0.55 to 0.90)	12.3 to 17.5 (0.85 to 1.21)
A6-553221	14 to 24 (0.97 to 1.66)	18.6 to 31.8 (1.28 to 2.19)
A6-653221	25 to 50 (1.73 to 3.45)	33.1 to 61 (2.28 to 4.21)
A6-753221	51 to 90 (3.52 to 6.21)	65.6 to 112.3 (4.53 to 7.75)
A6-853221	91 to 150 (6.28 to 10.35)	114.7 to 198.3 (7.94 to 13.68)

**SPECIFICATIONS**

**Service:** Air, motor oils, transmission oils, jet fuels, and similar hydrocarbon media. (Not for water use)  
**Wetted Materials:** Base: 304 SS; Diaphragm: Polyamide film.  
**Temperature Limits:** -40 to 248°F (-40 to 120°C).  
**Pressure Limits:** Operating pressure: 150 psi (10.3 bar) for 0.5-24 psi set point ranges, 250 psi (17.2 bar) for 25 to 150 psi set point ranges; Proof pressure: 500 psi (34.5 bar); Burst pressure: 750 psi (51.7 bar) for 0.5-24 psi set point ranges, 1250 psi (86.2 bar) for 25-150 psi set point ranges.  
**Enclosure Rating:** General purpose or with cover: IP65 - weatherproof.

**Repeatability:** ±10% of set point.  
**Set Point Tolerance:** ±15% of range.  
**Switch Type:** 1 SPST NO, 1 SPST NC. NO and NC switch independent from each other.  
**Electrical Ratings:** Resistive: 15 A @ 6 VDC, 8 A @ 12 VDC, 4 A @ 24 VDC; Inductive: 1 A @ 120 VAC, 0.5 A @ 240 VAC.  
**Electrical Connections:** #8-32 screw terminals.  
**Process Connection:** 1/4" NPT male.  
**Mounting Orientation:** Switch can be installed in any position.  
**Set point Adjustment:** Screw.  
**Weight:** 0.13 lb (0.06 kg).

**ACCESSORIES**

Model	Description
A-439	Weatherproof IP65 cover
A-440	Weatherproof IP65 with fly-wire holes

USA: California Proposition 65

⚠WARNING: Cancer and Reproductive Harm - www.P65Warnings.ca.gov



SERIES AP | MERCOID® BY DWYER

# DIAPHRAGM OPERATED PRESSURE SWITCH

Visible Set point Adjustment, Compact

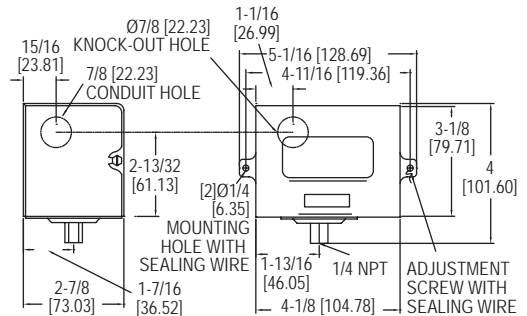

Reliable and convenient, the **Series AP Diaphragm Operated Pressure Switch** is a compact switch for instrument air or other low pressure applications. Visible set point and external adjustment add convenience. Used on air, non-corrosive gas or liquid service compatible with wetted parts. Units are available in weather-proof and explosion-proof housing.

**FEATURES/BENEFITS**

- Explosion-proof and weatherproof housing provides device protection for outdoor use or harsh environment operation
- External switch set point adjustment reduces set-up time

**APPLICATIONS**

- Low pressure applications
- Instrument air

**SPECIFICATIONS**

**Wetted Materials:** Nylon reinforced Buna-N and steel. PTFE and 316 SS optional.  
**Temperature Limits:** -30 to 150°F (-35 to 66°C).  
**Pressure Limit:** See model chart.  
**Enclosure Rating:** General purpose. Weatherproof and explosion-proof optional.  
**Switch Type:** SPDT mercury switch or SPDT snap switch. Other switch types available.  
**Electrical Rating:** Mercury switch: 4 A @ 120 VAC/DC, 2 A @ 240 VAC/DC; Snap switch: 15 A @ 120 VAC, 8 A @ 240 VAC, 0.5 A @ 120 VDC, 0.25 A @ 240 VDC.

**Electrical Connections:** Screw terminal.  
**Conduit Connection:** 7/8" (22.23 mm) hole for 1/2" (12.7 mm) conduit hub.  
**Process Connection:** 1/4" female NPT.  
**Mounting Orientation:** Vertical for mercury switch models, any position for snap switch models.  
**Set Point Adjustment:** External screw.  
**Weight:** General purpose: 2 lb (0.9 kg).  
**Deadband:** See model chart.  
**Agency Approvals:** FM, UL. For FM consult factory.

MODEL CHART					
Model	Switch* Type SPDT	Ranges	Switch Deadband		Max. Press. psig(bar)
			Low	High	
AP-153-33	Mercury	10 in VAC to 50 in w.c. (2.5 to 12.4 kPa)	5 in w.c. (1.2 kPa)	6 in w.c. (1.49 kPa)	15 (1.03)
AP-153-37	Mercury	1 to 30 psig (.07 to 2.1 bar)	0.4 psig (0.03 bar)	0.75 psig (0.05 bar)	60 (4.14)
AP-153-39	Mercury	10 to 125 psig (.69 to 8.6 bar)	2 psig (0.14 bar)	6 psig (0.04 bar)	160 (11.0)
AP-7021-153-33	Snap	10 in VAC to 50 in w.c. (2.5 to 12.4 kPa)	8 in w.c. (2.0 kPa)	10 in w.c. (2.49 kPa)	15 (1.03)
AP-7021-153-37	Snap	1 to 30 psig (.07 to 2.1 bar)	0.75 psig (0.05 bar)	1.5 psig (0.10 bar)	60 (4.14)
AP-7021-153-39	Snap	10 to 125 psig (.69 to 8.6 bar)	3 psig (0.21 bar)	7 psig (0.48 bar)	160 (11.0)

\*Mercury switch units are not CE approved.



# SUBMINIATURE PRESSURE SWITCH

Field Adjustable

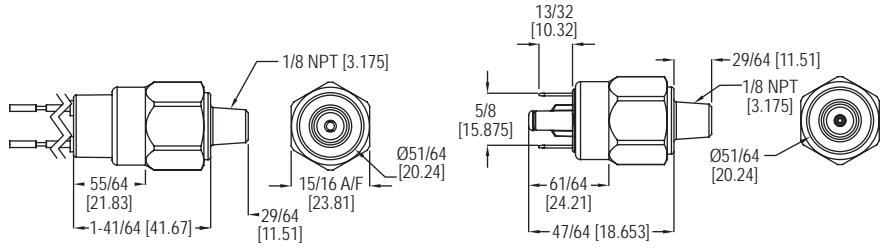

Designed for OEM applications, the **Series A2 Subminiature Pressure Switch** is economical and is equipped with high proof pressure capabilities for demanding applications. The A2 is available with either spade terminals or flying leads (submersible). Switches with spade terminals can be easily adjusted in the field.

**FEATURES/BENEFITS**

- High-proof pressure to meet application demands
- Easy adjustment reduces installation and service times

**APPLICATIONS**

- OEM

**SPECIFICATIONS**

**Service:** Compatible liquids and gases.  
**Wetted Materials:** Polyamide film and brass.  
**Temperature Limits:** -40 to 230°F (-40 to 110°C).  
**Pressure Limits:** 350 psi (24 bar).  
**Enclosure Rating:** IP69 (flying lead models only).  
**Repeatability:** ±3% of highest set point at 70°F (21°C).  
**Switch Type:** SPST, 100 VA, 42 VDC.  
**Electrical Connection:** 1/4" (6.3 mm) spade terminals or flying leads.  
**Process Connection:** 1/8" male NPT, or 1/4" male NPT.  
**Weight:** 0.15 lb (0.07 kg).  
**Deadband:** <10% of actuation point.  
**Agency Approvals:** CE.

MODEL CHART							
Model	Range psi (bar)	Electrical Connection	NO/NC	Model	Range psi (bar)	Electrical Connection	NO/NC
A2-5801	2 to 20 (0.14 to 1.4)	Spade terminals	NO	A2-6811	15 to 100 (1.03 to 6.9)	Spade terminals	NC
A2-5803	2 to 20 (0.14 to 1.4)	Flying leads	NO	A2-6813	15 to 100 (1.03 to 6.9)	Flying leads	NC
A2-5811	2 to 20 (0.14 to 1.4)	Spade terminals	NC	A2-7801	50 to 150 (3.5 to 10.3)	Spade terminals	NO
A2-5813	2 to 20 (0.14 to 1.4)	Flying leads	NC	A2-7803	50 to 150 (3.5 to 10.3)	Flying leads	NO
A2-6801	15 to 100 (1.03 to 6.9)	Spade terminals	NO	A2-7811	50 to 150 (3.5 to 10.3)	Spade terminals	NC
A2-6803	15 to 100 (1.03 to 6.9)	Flying leads	NO	A2-7813	50 to 150 (3.5 to 10.3)	Flying leads	NC

USA: California Proposition 65  
 ⚠WARNING: Cancer and Reproductive Harm - www.P65Warnings.ca.gov

**SERIES MVS**

# MINIATURE VACUUM SWITCH

SPDT N/O or N/C Switch, Adjustable Set Point, Ideal for OEM's

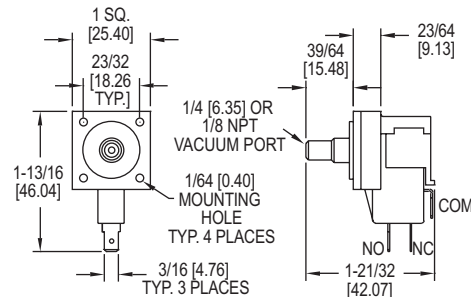

Compact, lightweight, and adjustable, the **Series MVS Miniature Vacuum Switch** is specially designed for OEM applications. This low cost switch has a minimum life expectancy of 10 million cycles and has an extremely fast response time. Typical applications for the MVS are HVAC, home appliance, dairy systems, medical, office equipment, and pump control.

**FEATURES/BENEFITS**

- High switch cycle means long life for extended duty applications

**APPLICATIONS**

- OEM
- HVAC applications
- Medical equipment
- Dairy equipment
- Pump control

MODEL CHART		
Model	Set Point in H <sub>2</sub> O (mbar)	
	Minimum	Maximum
MVS-1	3 (8)	8 (20)
MVS-2	9 (21)	80 (199)
MVS-3	81 (200)	330 (822)
MVS-4*	3 (8)	8 (20)
MVS-5*	9 (21)	80 (199)
MVS-6*	81 (200)	330 (822)

\*Models have 1/8" male NPT process connections

**SPECIFICATIONS**

**Service:** Air or compatible fluids.  
**Wetted Materials:** Enclosure: Polycarbonate; Diaphragm: Polyurethane.  
**Temperature Limits:** 40 to 150°F (4 to 66°C).  
**Pressure Limits:** Up to maximum range.  
**Repeatability:** ±20%.  
**Switch Type:** SPDT normally open or normally closed.  
**Electrical Rating:** Range 3 to 8 in w.c.: 3 A, 125/250 VAC; Range 9 to 80 in w.c.: 10 A, 125/250 VAC; Range 81 to 330 in w.c.: 15 A, 125/250 VAC.  
**Contacts:** Silver with brass terminals.  
**Electrical Connections:** Terminals 0.187" x 0.20" spade for use with quick disconnects.  
**Process Connections:** Models MVS 1 to MVS 3: Smooth port 0.25" diameter; Models MVS 4 to MVS 6: 1/8" male NPT.  
**Mounting:** Use #2 screws through eyelets.  
**Weight:** Less than 0.671 oz (19 g.)  
**Agency Approvals:** cULus.





SERIES CXA | MERCOID® BY DWYER

# WATER PUMP PRESSURE SWITCH

Simple, Reliable, Adjustable Set Point and Deadband

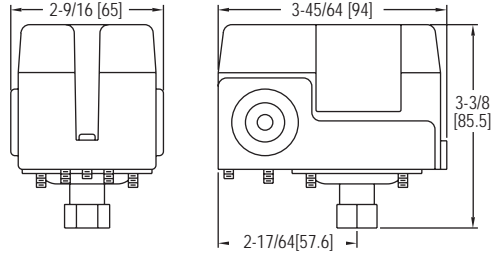
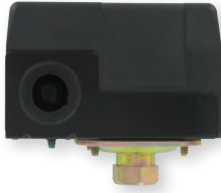

The **Series CXA Water Pump Pressure Switch** has been proven reliable for controlling automatic water systems. These switches are very popular for use on water well pumps and pumping systems. The set point and dead-band are both easily adjustable via screws inside the cover. For ease of installation, the switches come with a 1/4" female NPT process connection and can be mounted in any orientation. The series CXA's simple design makes it a great switch for an installer at any skill level.

**FEATURES/BENEFITS**

- The set point and deadband are both easily adjustable reducing time to install and operation
- Mounting in any position and feature simple makes a reliable switch that can be installed by any skill level

**APPLICATIONS**

- Electric water pumps
- Water system applications
- Well pumps
- Pumping systems

**SPECIFICATIONS**

**Service:** Compatible liquids and gases.  
**Wetted Materials:** Silicone, steel, and SS.  
**Temperature Limits:** 140°F (60°C).  
**Pressure Limits:** See model chart.  
**Enclosure Rating:** General purpose.  
**Repeatability:** ±5 psig (±0.3 bar).  
**Switch Type:** DPST snap action (see model chart).  
**Electrical Ratings:** 20 A @ 120 VAC, 12 A @ 240 VAC, 9.6 A @ 240 VAC (3 phase), 8.6 A @ 32 VDC, 3.1 A @ 120 VDC, 1.6 A @ 240 VDC.  
**Electrical Connections:** Screw terminal.  
**Conduit Connection:** 7/8" hole for 1/2" conduit hub (2 places).  
**Process Connection:** 1/4" female NPT.  
**Mounting Orientation:** Switch can be installed in any position.  
**Set Point Adjustment:** Internal screws.  
**Weight:** 0.75 lb (0.34 kg).  
**Deadband:** See model chart.

**MODEL CHART**

Model	Switch Type	Range psig (bar)	Approx. Adjustable Deadband psig (bar)	Max. Pressure psig (bar)
CXA-S1	NC	15 to 80 (1.0 to 5.5)	15 to 30 (1.0 to 2.1)	129 (8.9)
CXA-S2	NC	30 to 100 (2.1 to 6.9)	20 to 35 (1.4 to 2.4)	179 (12.3)
CXA-S3	NC	35 to 150 (2.4 to 10.3)	30 to 40 (2.1 to 2.8)	204 (14.1)
CXA-R1	NO	15 to 80 (1.0 to 5.5)	15 to 30 (1.0 to 2.1)	129 (8.9)
CXA-R2	NO	30 to 100 (2.1 to 6.9)	20 to 35 (1.4 to 2.4)	179 (12.3)
CXA-R3	NO	35 to 150 (2.4 to 10.3)	30 to 40 (2.1 to 2.8)	204 (14.1)

**SERIES 681**

# SANITARY PRESSURE TRANSMITTER

No Liquid Fill Diaphragm, Sanitary Clamp Fitting

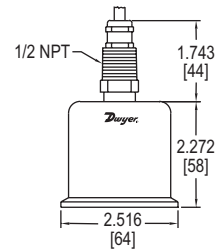

The **Series 681 Sanitary Pressure Transmitter** is designed to meet 3A standards for applications in food, dairy, beverage and pharmaceutical processing, liquid level control, and sanitary pipelines. The unit is fully sealed to withstand high pressure wash-down in Clean-in-Place (CIP) and Sterilize-in-Place (SIP) installations. The Series 681 is designed with a unique, no liquid fill diaphragm and a sanitary clamp pressure fitting for easy installation with negligible clamping effect. A conduit fitting, shielded cable with vent tube and sealed screws for zero and span adjustment combine to make the Series 681 completely watertight.

**FEATURES/BENEFITS**

- Fully sealed to withstand Clean-in-Place and Sterilize-in-Place installations supports regulatory conditions for sanitary processes
- Sanitary clamp fitting makes for easy installation

**APPLICATIONS**

- Sanitary process applications
- Food and beverage processing
- Water processing
- Dairy processing
- Pharmaceutical processing

**MODEL CHART**

Model	Range	Overpressure	Sanitary Clamp Connection
681-02	0 to 1 psi	50 psi	2"
681-12	0 to 2 psi	100 psi	2"
681-42	0 to 15 psi	150 psi	2"
681-52	0 to 30 psi	150 psi	2"
681-62	0 to 60 psi	180 psi	2"

**SPECIFICATIONS**

**Service:** Compatible liquids and gases.  
**Wetted Parts:** 316L SS.  
**Accuracy:** ±20% FS (includes non-linearity, hysteresis and non-repeatability).  
**Temperature Limits:** -40 to 260°F (-40 to 125°C) 10 to 90% RH, non-condensing.  
**Pressure Limits:** See table.  
**Compensated Temperature Range:** 20 to 180°F (-7 to 80°C).  
**Thermal Effect:** Zero and span shift: ±2.0% FS/100°F.  
**Power Requirements:** 9-30 VDC.  
**Output Signal:** 4-20 mA, 2-wire.  
**Zero and Span Adjustment:** ±0.5 mA, non-interactive.  
**Response Time:** ≤ 10 ms.  
**Loop Resistance:** 800 Ω.  
**Electrical Connections:** 1/2" conduit fitting and strain relief with 15 ft (4.5 m) cable.  
**Process Connection:** 2" or 1-1/2" sanitary clamp fitting male NPT.  
**Clamping Effect:** Zero and span shift: ±0.15% FS for ranges up to 30 psi; ±0.25% FS for ranges >30 psi.  
**Weight:** 8 oz (227 g).

**OPTIONS**

Use order code:	Description
NISTCAL-PT1	NIST traceable calibration certificate for pressure transmitters

# HIGH ACCURACY PRESSURE TRANSMITTER

±0.05% FS, <±0.25% FS Total Error Band

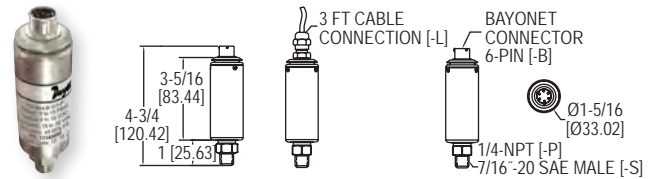

The **Series 644 High Accuracy Pressure Transmitter** is a robust transmitter designed for high accuracy pressure applications. Boasting an accuracy of ±0.05% FS RSS (<±0.25% TEB), the 644 is intended for precise measurements in the critical applications.

**FEATURES/BENEFITS**

- High accuracy provides exceptional measurement for insuring tight-control and minimizing costly out of specification conditions
- NIST calibrated to provide traceability for regulated processes where production and documentation is monitored
- Low thermal error over a wide range of temperatures helps to insure accurate pressure measurement and process operation

MODEL CHART						
Example	644	-L	-V	-00	-P	644-L-V-00-P
Series	644					Industrial pressure transmitter
Electrical Connection		L				3 ft cable Male 6-pin bayonet
Signal Output			V			0-10 V 4-20 mA
Range				00		0 to -14.7 psig
				01		0 to 15 psig
				02		0 to 25 psig
				03		0 to 50 psig
				04		0 to 100 psig
				05		0 to 150 psig
				06		0 to 200 psig
				07		0 to 300 psig
				08		0 to 500 psig
				09		0 to 750 psig
				10		0 to 1000 psig
				11		0 to 15 psia
Process Connection					P	1/4" male NPT
					S	7/16"-20 SAE male

**SPECIFICATIONS**

**Service:** Compatible gases and liquids.  
**Wetted Materials:** 17- 4 PH SS.  
**Accuracy:** ±0.05% FS RSS.  
**Total Error Band (Includes all thermal effects):** <±0.25% FS over entire temperature compensated range.  
**Stability:** < 0.15% FS/year.  
**Temperature Limits:** -40 to 185°F (-40 to 85°C).  
**Pressure Limits:** Proof pressure and burst pressure: See pressure limits table below.  
**Compensated Temperature Range:** -4 to 140°F (-20 to 60°C).  
**Power Requirements:** 9-30 VDC for current output; 15-30 VDC for voltage output.  
**Minimum Supply Voltage:** Min. supply voltage (VDC) for current output = 9 + 0.02 x loop resistance Ω (loop resistance Ω = line resistance + receiver resistance).  
**Output Signal:** 0-10 VDC (4-wire); 4-20 mA (2-wire).  
**Response Time:** < 10 ms (voltage output), < 80 ms (current output).  
**Max Current Consumption:** 4-20 mA: 22 mA; 0-10 VDC: 20 mA.  
**Electrical Connections:** 3 ft cable or 6-pin male bayonet connector.  
**Process Connection:** 1/4" male NPT or 7/16"-20 male SAE with O-ring.  
**Enclosure Rating:** NEMA 4X (IP65).  
**Mounting Orientation:** Vertical.  
**Weight:** 9 oz (254 g).  
**Agency Approvals:** CE.

**APPLICATIONS**

- Calibration equipment
- Hydraulic/pneumatic controls
- Test benches
- Transportation
- Pulp and paper mills
- Power generation

**ACCESSORIES**

Model	Description
A-495	6-pin female bayonet mate connector

SERIES 638R

# OEM PRESSURE TRANSMITTER

Excellent Pressure Surge Resistance, Fast Response

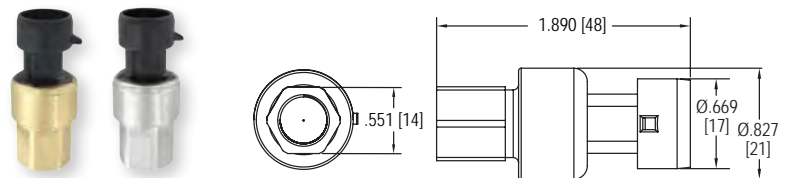

The **Series 638R OEM Pressure Transmitter** is a high-accuracy, low-cost pressure transmitter designed for industrial equipment markets. This transmitter is designed to work with all liquids and gases that are compatible with the wetted materials. The series features a number of configurable options including wetted materials, process connections, and pressure ranges. Whether the application involves aggressive fluids or extreme temperatures, this transmitter is a great option for most applications.

**FEATURES/BENEFITS**

- High-accuracy pressure transmitter with a fast response time and excellent pressure surge protection
- Suitable for use in applications with extreme temperatures and aggressive fluids
- Highly configurable cost-effective transmitter with a compact design

**APPLICATIONS**

- HVAC equipment
- Refrigeration equipment
- Refrigerant recovery
- Leak detection systems
- Building pressurization
- Isolated diaphragm packages
- Closed loop hydraulics
- Paint and agriculture spraying

**SPECIFICATIONS**

**Service:** Compatible gases and liquids.  
**Wetted/Housing Materials:** Brass, aluminum, or 316 SS.  
**Accuracy:** ±1.2% FS (includes linearity, hysteresis, repeatability and calibration); Static error band @ 25°C, 5.0 VDC supply voltage.  
**Cycle Life:** 10 million FS cycles.  
**Storage Temperature:** -40 to 302°F (-40 to 150°C).  
**Operating Temperature:** -40 to 275°F (-40 to 135°C).  
**Pressure Limit:** see model chart.  
**Thermal Effect:** ± 0.013% FS/°C.  
**Power Supply:** 5 VDC.  
**Output Signal:** 0.5-4.5 VDC ratiometric.  
**Response Time:** 10 ms typical.  
**Output Load:** 20 k Ω min. (pull-up or pull-down).  
**Current Consumption:** < 10 mA @ 5.5 VDC (8.5 mA typical).  
**Electrical Connection:** Packard connection.  
**Process Connection:** 7/16" 20 UNF (female) or 1/4" NPT (female).  
**Enclosure Rating:** IP67 (with IP67 plug).  
**Mounting Orientation:** Mount in any position.  
**Weight:** 1.1 oz (30 g).  
**Agency Approvals:** CE.

MODEL CHART							
Example	638R	-00	-P2	-E1	-S2	-SS	638R-00-P2-E1-S1-SS
Series	638R						OEM pressure transmitter
Pressure Range		00					0 to 75 psia (0 to 5.2 bar(a))
		01					0 to 150 psia (0 to 10.3 bar(a))
		02					0 to 200 psia (0 to 13.8 bar(a))
		03					14.5 to 265 psia (1 to 18.3 bar)
		04					14.5 to 315 psia (1 to 21.7 bar(a))
		05					14.5 to 515 psia (1 to 35.5 bar(a))
		06					14.5 to 667 psia (1 to 46 bar(a))
Process Connection			P1				7/16" 20 UNF (female)
			P2				1/4" NPT (female)
Electrical Connection				E1			Packard connection
Electrical Output					S2		0.5-4.5 V ratiometric
Housing Material						AL	Aluminum
						BR	Brass
						SS	316L SS

**Dwyer**  
SERIES 682

# INDUSTRIAL PRESSURE TRANSMITTER

±0.13% FS Accuracy, External Adjustments, 4-20 mA Output

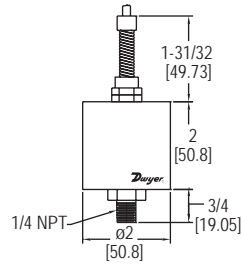

The Series 682 Industrial Pressure Transmitter is designed to withstand environmental effects such as shock, vibration, temperature, and EMI/RFI. The electronics and capacitive sensor are packaged in a welded stainless steel housing and meets NEMA 4 (IP65) protection ratings.

**FEATURES/BENEFITS**

- Weather-proof welded housing provides device protection for outdoor use or harsh environment operation
- Not affected by environmental effects such as temperature, shock, vibration, and EMI/RFI provides reliable switching for equipment
- External span and zero adjustments reduce installation and service time

**APPLICATIONS**

- Off-road equipment
- Compressor control
- Industrial refrigeration
- Hydraulic systems
- Industrial engines

MODEL CHART					
Model*	Range	Overpressure	Model*	Range	Overpressure
682-1	0 to 50 psi	150 psi	682-3	0 to 250 psi	500 psi
682-2	0 to 100 psi	300 psi	682-4	0 to 500 psi	1000 psi

\*Units calibrated in bar also available. Consult factory.

**SPECIFICATIONS**

**Service:** Compatible liquids and gases.  
**Wetted Parts:** 17-4 PH SS.  
**Accuracy:** ±0.13% FS (includes non-linearity, hysteresis and non-repeatability).  
**Temperature Limits:** -40 to 260°F (-40 to 125°C) 10 to 90% RH, non-condensing.  
**Pressure Limit:** See table.  
**Compensated Temperature Range:** -4 to 176°F (-20 to 80°C).  
**Thermal Effect: Zero shift:** 1.0% FS/100°F span shift: ±1.5% FS/100°F.

**Power Requirements:** 9-30 VDC.  
**Output Signal:** 4-20 mA, 2-wire.  
**Zero and Span Adjustment:** ±0.5 mA, non-interactive.  
**Response Time:** 5 ms.  
**Loop Resistance:** 800 Ω.  
**Electrical Connections:** 2 ft (51 cm) multiconductor cable.  
**Process Connection:** 1/4" male NPT.  
**Weight:** 8 oz (227 g).  
**Shock:** 200 g operating.  
**Vibration:** 20 g 50-2000 Hz.

**OPTIONS**

Use order code:	Description
NISTCAL-PT1	NIST traceable calibration certificate

**SERIES 672**

# LOW PRESSURE TRANSDUCER

Single Pressure Connection, Ranges down to 10 in w.c.

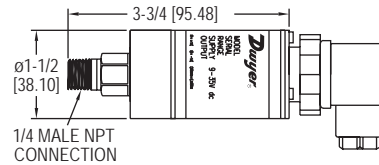

The Series 672 Low Pressure Transducer is a perfect solution to any The Series 672 Low Pressure Transducer is a perfect solution to any application where a very accurate low pressure transducer is necessary. Using variable capacitance technology, the Series 672 is designed to measure pressures as low as 10 in w.c. up to 400 in w.c., very low ranges for a single connection pressure transducer. The 672 also features a 0.25% FS accuracy. Use the Series 672 in liquid level, flood warning, waste water, clean room, and open channel flow applications.

**FEATURES/BENEFITS**

- Low range high accuracy provides precise control for process applications

**APPLICATIONS**

- Liquid level
- Flood warning
- Waste water
- Clean room
- Open flow applications

MODEL CHART		
Model	Operating Range	Output
672-1-A	0 to 10 in w.c.	4-20 mA, 2-wire
672-2-A	0 to 15 in w.c.	4-20 mA, 2-wire
672-3-A	0 to 25 in w.c.	4-20 mA, 2-wire
672-4-A	0 to 50 in w.c.	4-20 mA, 2-wire
672-5-A	0 to 100 in w.c.	4-20 mA, 2-wire
672-6-A	0 to 150 in w.c.	4-20 mA, 2-wire
672-7-A	0 to 200 in w.c.	4-20 mA, 2-wire
672-8-A	0 to 300 in w.c.	4-20 mA, 2-wire
672-9-A	0 to 400 in w.c.	4-20 mA, 2-wire

**Note:** For voltage output models change -A to -V.

**SPECIFICATIONS**

**Service:** Compatible liquids and gases.  
**Wetted Materials:** 318 duplex SS, ceramic, fluoroelastomer (FKM).  
**Housing Material:** 318 stainless steel.  
**Accuracy:** ±0.25% FS (RSS). Includes non-linearity, hysteresis, and non-repeatability.  
**Stability:** 0.25% FS/1 year.  
**Temperature Limits:** -40 to 212°F (-40 to 100°C).  
**Compensated Temperature Limits:** -5 to 140°F (-20 to 60°C).  
**Pressure Limits:** 29 psi (2 bar) for up to 85 in w.c. (0.2 bar) ranges; 58 psi (4 bar) for 85 to 140 in w.c. (0.2 to 0.35 bar); 73 psi (5 bar) for 141 to 400 in w.c. (0.35 to 1 bar).  
**Thermal Effects:** Zero: 1.0%FS/100°F (2.0%FS/100°C); Span: 1.0%FS/100°F (2.0%FS/100°C).  
**Power Requirements:** 4-20 mA: 9-35 VDC; 0-5 VDC: 7.5-35 VDC.  
**Output Signal:** 4-20 mA (2-wire) or 0-5 VDC (3-wire).  
**Zero & Span Adjustment:** ±10% FS each (by potentiometer).  
**Response Time:** 5 ms.  
**Max Loop Resistance:** 1.325 kΩ.  
**Electrical Connections:** Large DIN 43650 connector with mating plug.  
**Process Connection:** 1/4"-18 NPT male.  
**Enclosure Rating:** NEMA 4X (IP66).  
**Weight:** 11.6 oz (330 g).

**OPTIONS**

Use order code:	Description
NISTCAL-PT1	NIST traceable calibration certificate



# PRESSURE TRANSMITTER

±0.25% FS Accuracy, 4-20 mA Signal, Ranges to 1000 psi

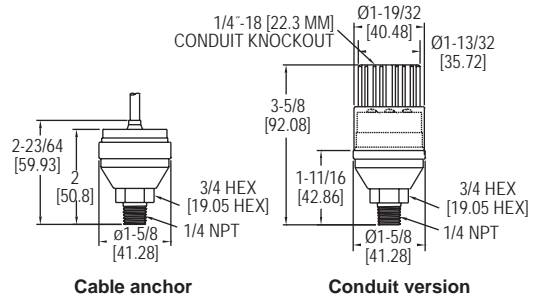
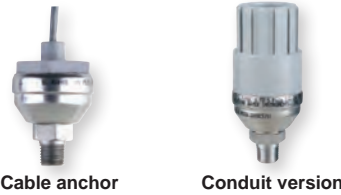

The low cost **Series 673 Pressure Transmitter** is a fixed range transmitter designed for harsh environments and suitable for high shock and vibration applications. Constructed of stainless steel, the Series 673 provides a 4-20 mA output signal with 0.25% accuracy. Use the Series 673 in industrial OEM equipment, hydraulic systems, HVAC equipment, industrial engines and compressor control.

**FEATURES/BENEFITS**

- High-shock and vibration resistant insures stability in controlling pressure for process applications

**APPLICATIONS**

- OEM
- Industrial engines
- Hydraulic systems
- Compressors
- HVAC equipment

MODEL CHART			
Model	Range psi	Model	Range psi
673-1	0 to 1	673-1C	0 to 1
673-2	0 to 2	673-2C	0 to 2
673-3	0 to 5	673-3C	0 to 5
673-4	0 to 10	673-4C	0 to 10
673-5	0 to 25	673-5C	0 to 25
673-6	0 to 50	673-6C	0 to 50
673-7	0 to 100	673-7C	0 to 100
673-8	0 to 200	673-8C	0 to 200
673-9	0 to 500	673-9C	0 to 500
673-10	0 to 1000	673-10C	0 to 1000
673-14	-14.7 to 100	673-14C	-14.7 to 100

\*The model numbers followed by a "C" represent the conduit version, which is hand tightened to ensure proper electrical seal.

SPECIFICATIONS	
<b>Service:</b> Liquid, gas, or vapor.	
<b>Wetted Materials:</b> 17-4 PH SS.	
<b>Accuracy:</b> ±0.25% FS (RSS), (includes non-linearity, hysteresis and non-repeatability).	
<b>Temperature Limits:</b> -40 to 185°F (-40 to 85°C).	
<b>Compensated Temperature Limits:</b> -40 to 176°F (-40 to 80°C).	
<b>Pressure Limits:</b> 2 x max range.	
<b>Thermal Errors:</b> Zero: ±3.6% FS/100°F(100°C); Span: ±2.7% FS/100°F(100°C).	
<b>Power Requirements:</b> 9-30 VDC.	
<b>Output:</b> 4-20 mA, 2-wire.	
<b>Zero &amp; Span Adjustment:</b> Fixed.	
<b>Response Time:</b> 5 ms.	
<b>Loop Resistance:</b> 0 to 800 Ω.	
<b>Stability:</b> 0.5% FS/year.	
<b>Shock:</b> 200 g.	
<b>Vibration:</b> 20 g.	
<b>Electrical Connections:</b> 2 ft (61 cm) multiconductor cable.	
<b>Conduit Connection:</b> 1/4"-18 (22.3 mm) knockout.	
<b>Enclosure:</b> Stainless steel and Valox.	
<b>Weight:</b> 2.3 oz (65 g).	

OPTIONS	
Use order code:	Description
NISTCAL-PT1	NIST traceable calibration certificate

**SERIES FDT**

# FLUSH DIAPHRAGM TRANSMITTER

Non-Liquid Filled, ±0.5% FS Accuracy, SS Wetted Parts

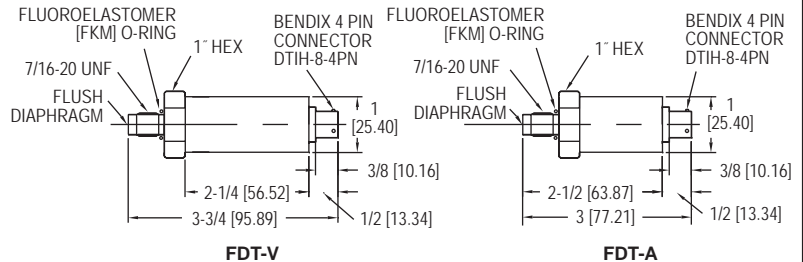

The **Series FDT Flush Diaphragm Transmitter** is designed for highly cyclical conditions. Flush sensor feature prevents any potential inaccuracies due to build-up or blockage which is a typical problem found in most non-flush transmitter sensors.

**FEATURES/BENEFITS**

- Performs well in high cyclical environments with the presence of water-hammering or spiking for long service life

**APPLICATIONS**

- OEM
- Hydraulic systems
- Process systems

MODEL CHART					
Example	FDT	-A	-01	-NPT	FDT-A-01-NPT
<b>Series</b>	FDT				Flush diaphragm transmitter
<b>Output</b>		A V			4-20 mA 0-5 VDC
<b>Range</b>			01 02 03 04 06 11 12 15		100 psi 150 psi 200 psi 300 psi 500 psi 1000 psi 2000 psi 5000 psi
<b>Options</b>				-NPT -C08	1/4" male NPT 0.25% FS accuracy

**Note:** Contact factory for additional range availability.

SPECIFICATIONS	
<b>Service:</b> Compatible liquids and gases, adhesives, slurries, materials that can harden, or where a pressure cavity is not desired.	
<b>Wetted Materials:</b> 316 & 15-5 SST.	
<b>Accuracy:</b> ±0.5% FS (includes non-linearity, hysteresis, and repeatability).	
<b>Stability:</b> ±0.25% FS per year.	
<b>Temperature Limits:</b> -40 to 200°F (-40 to 93°C).	
<b>Compensated Temperature Limits:</b> 0 to 170°F (-18 to 77°C).	
<b>Pressure Limit:</b> 150% FS; Burst: 200% FS.	
<b>Thermal Effect:</b> ±1.5% FSO over compensated range.	
<b>Power Requirements:</b> 8-38 VDC.	
<b>Output Signal:</b> FDT-A: 4-20 mA DC; FDT-V: 0-5 VDC.	
<b>Response Time:</b> <1 ms.	
<b>Loop Resistance:</b> FDT-A: 0 to 1.5 Ω; FDT-V: 100 Ω.	
<b>Electrical Connections:</b> 4-pin.	
<b>Process Connection:</b> 7/16-20 UNF male flush diaphragm. Optional 1/4" male NPT.	
<b>Enclosure Rating:</b> NEMA 4X (IP66).	
<b>Mounting Orientation:</b> Mount in any position.	
<b>Weight:</b> 2 oz (57 g).	
<b>Agency Approvals:</b> CE.	

ACCESSORIES	
Model	Description
A-168	Mating connector for 4 pin M-12

OPTIONS	
Use order code:	Description
NISTCAL-PT1	NIST traceable calibration certificate



# INDUSTRIAL PRESSURE TRANSMITTERS

Complete Offering of Ranges, Connections and Outputs



626/628 pressure transmitters  
with general purpose housing (-GH)



626/628 pressure transmitters  
with conduit box housing (-CB) and LCD display



\*Please see our website for dimensional drawings.

The **Series 626 Industrial Pressure Transmitters** possess a highly precise 0.25% full-scale accuracy piezo-resistive sensor contained in a compact, rugged, NEMA 4X (IP66) stainless steel general purpose housing or cast aluminum conduit housing. The **Series 628 Industrial Pressure Transmitters** are ideal for OEMs with 1% full-scale accuracy sensors. The corrosion resistant 316L stainless steel wetted parts allow the Series 626 and 628 transmitters to measure the pressure in a multitude of processes from hydraulic oils to chemicals. The Series 626 and 628 are available in absolute and pressure ranges with a variety of optional outputs, process connections and electrical terminations to allow you to select the right transmitter for your application.

## FEATURES/BENEFITS

- NEMA 4X rated enclosure provides protection in harsh environments permitting outdoor monitoring or in areas where dust and particulate matter exists
- Robust 316 SS oil filled sensor provides shock and vibration resistance insuring stability in controlling pressure for process applications
- A wide range of models and connections that can meet pressure measurement specifications from low to very high

## APPLICATIONS

- Compressors
- Pumping systems
- Irrigation equipment
- Hydraulic
- Industrial process monitoring

## SPECIFICATIONS

**Service:** Compatible gases and liquids.

**Wetted Materials:** Type 316L SS.

**Accuracy:** 626: 0.25% FS; 626: 0.20% RSS; 628: 1.0% FS; 628: 0.5% RSS; 626 Absolute Ranges: 0.5% FS; 626 absolute ranges: 0.30% RSS. (Includes linearity, hysteresis, and repeatability.)

**Temperature Limit:** 0 to 200°F (-18 to 93°C).

**Compensated Temperature Range:** 0 to 175°F (-18 to 79°C).

**Thermal Effect:** ±0.02% FS/°F (includes zero and span).

**Pressure Limits:** See table.

**Power Requirements:** 10-30 VDC (for 4-20 mA, 0-5, 1-5, 1-6 VDC outputs); 13-30 VDC (for 0-10, 2-10 VDC outputs); 5 VDC ±0.5 VDC (for 0.5-4.5 VDC ratio-metric output), 10-35 VDC (for 4-20 mA with -CB option); 13-35 VDC or isolated 16-33 VAC (for selectable output with -CB option).

**Output Signal:** 4-20 mA, 0-5 VDC, 1-5 VDC, 0-10 VDC, or 0.5-4.5 VDC, or selectable 0-5, 1-5, 0-10, 2-10 VDC for -CB option.

**Response Time:** 300 ms.

**Loop Resistance:** 0 to 1000 Ω max. R max = 50 (Vps-10) Ω (4-20 mA output), 0-1250 Ω max. Rmax = 50(Vps-10) Ω (4-20 mA output with -CB option), 5K Ω (0-5, 1-5, 1-6, 0-10, 2-10, 0.5-4.5 VDC output).

**Stability:** 1.0% FS/year (Typ.).

**Current Consumption:** 38 mA maximum (for 4-20 mA output); 10 mA maximum (for 0-5, 1-5, 1-6, 0-10, 2-10, 0.5-4.5 VDC output); 140 mA maximum (for all 626/628/629-CH with optional LED).

**Electrical Connections:** Conduit Housing (-CH): terminal block, 1/2" female NPT conduit; General Purpose Housing (-GH): cable DIN EN 175801-803-C.

**Process Connection:** 1/4" male or female NPT and BSPT.

**Enclosure Rating:** NEMA 4X (IP66).

**Mounting Orientation:** Mount in any position.

**Weight:** 10 oz (283 g).

**Agency Approvals:** CE, NSF, UL.

# INDUSTRIAL PRESSURE TRANSMITTERS

Complete Offering of Ranges, Connections and Outputs

MODEL CHART								
Example	626	-00	-CH	-P1	-E1	-S1	-AT	626-00-CH-P1-E1-S1-AT
Accuracy	626 628							0.25% full-scale accuracy 1.0% full-scale accuracy
Range		00 01 02 03 04 05 06 07 08 09 10 11 12 13 14 22 15 16 18 19 26 67 71 75 81						0 to 15 psia <sup>⑤</sup> 0 to 30 psia <sup>⑤</sup> 0 to 50 psia <sup>⑤</sup> 0 to 100 psia <sup>⑤</sup> 0 to 200 psia <sup>⑤</sup> 0 to 300 psia <sup>⑤</sup> 0 to 5 psi 0 to 15 psi 0 to 30 psi 0 to 50 psi 0 to 100 psi 0 to 150 psi 0 to 200 psi <sup>⑥</sup> 0 to 300 psi <sup>⑥</sup> 0 to 500 psi <sup>⑥</sup> 0 to 600 psi <sup>⑥</sup> 0 to 1000 psi 0 to 1500 psi <sup>⑥</sup> 0 to 3000 psi 0 to 5000 psi 0 to 8000 psi 0 to 0.5 bar 0 to 2.5 bar 0 to 10 bar 0 to 40 bar
Housing			CB GH					Conduit box housing General purpose housing
Process Connection				P1 P2 P3 P5 P9				1/4" male NPT 1/4" female NPT 1/4" male BSPT 1/4" female SAE with refrigerant valve depressor <sup>①</sup> 1/2" male NPT <sup>②</sup>
Electrical Connection					E1 E3 E4 E5 E6 E8 E9			Cable gland with 3' of prewired cable Cable gland with 9' of prewired cable DIN EN 175801-803-C <sup>③</sup> 1/2" female NPT conduit <sup>③</sup> M-12 4 pin connector-UL <sup>④</sup> Packard connector M-12 4 pin connector non-UL
Signal Output						S1 S2 S4 S5 S7 S8		4-20 mA 1-5 VDC 0-5 VDC 0-10 VDC 0.5-4.5 VDC <sup>①③</sup> Selectable 0-5, 1-5, 0-10, 2-10 VDC <sup>③</sup>
Options							AT LCD NIST NW	Aluminum tag LCD indication <sup>③</sup> NIST traceable certificate NSF/ANSI 61/372 certified
<sup>①</sup> Available with -GH housing only, NEMA 4 (IP65) <sup>②</sup> Available with -CB housing only <sup>③</sup> Power requirement: 5 VDC ±10% <sup>④</sup> Available with -GH housing only <sup>⑤</sup> Absolute ranges for 626 are 0.5% FS accuracy and for 628 are 2% FS accuracy <sup>⑥</sup> UL listed pump controllers, fire-component - See online certificate for information and limitations								
<b>Note:</b> Bar and absolute ranges are only available with -GH housing.								

PRESSURE LIMITS							
Range Number	Pressure Range	Maximum Pressure (psig)	Over Pressure (psig)	Range Number	Pressure Range (psig)	Maximum Pressure (psig)	Over Pressure (psig)
00	0 to 15 psia	30	45	12	0 to 200	400	1000
30	15 to 0 psia	30	45	13	0 to 300	600	1500
06	0 to 5 psig	10	50	14	0 to 500	1000	2500
07	0 to 15 psig	30	150	15	0 to 1000	2000	5000
08	0 to 30 psig	60	300	16	0 to 1500	3000	5000
09	0 to 50 psig	100	300	18	0 to 3000	6000	7500
10	0 to 100 psig	200	500	19	0 to 5000	7500	10000
11	0 to 150 psig	300	750	26	0 to 8000	10000	12000

ACCESSORIES	
Model	Description
A-164	16.4' (5 m) cable with M-12 4-pin female connector
A-62X-LCD	Field-upgradeable LCD
A-960	3' packard cable
A-961	9' packard cable
A-962	20' packard cable

# FIXED RANGE PRESSURE TRANSMITTER

Stainless Steel, Explosion-Proof, Accuracy  $\pm 0.30\%$ , 4-20 mA or 1-5 VDC Signal

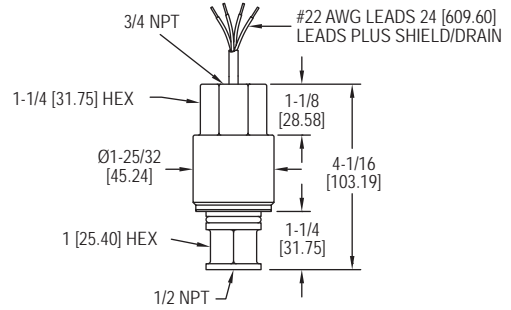

The **Series 636 Fixed Range Pressure Transmitter** is a low cost, fixed range, stainless steel transmitter with  $\pm 0.30\%$  accuracy. It is designed to continuously measure pressure for years in even the toughest environmental and media conditions. Transmitters are explosion-proof, (FM approved) and meet NACE standards for off-shore applications.

**FEATURES/BENEFITS**

- Long service life and lower cost to maintain reduces total cost of ownership
- Explosion-proof housing for use in applications where protection of process and personnel is needed

**APPLICATIONS**

- Off-shore
- Process applications

MODEL CHART			
4-20 mA OUT	1-5 VDC OUT	Operating Range, psi	Operating Range, Bar
636-0	636-0-LP	0 to 15	0 to 1
636-1	636-1-LP	0 to 30	0 to 2
636-2	636-2-LP	0 to 100	0 to 7
636-3	636-3-LP	0 to 300	0 to 20

OPTIONS	
Use order code:	Description
NISTCAL-PT1	NIST traceable calibration certificate

**SPECIFICATIONS**

**Service:** Liquid, gas or vapor.  
**Wetted Materials:** 316 L SS.  
**Fill Fluid:** DC 200 silicone (standard).  
**Accuracy:**  $\pm 0.30\%$  of calibrated span.  
**Stability:**  $\pm 0.5\%$  of upper range limit for six months.  
**Temperature Limits:** Electronics (ambient): -40 to 140°F (-40 to 60°C); Process interface: -40 to 212°F (-40 to 100°C).  
**Pressure Limits:** 300% upper range limit.  
**Compensated Temperature Range:** -20 to 180°F (-29 to 82°C).  
**Thermal Effect:** (includes zero and span). Between -20 and 180°F (-29 and 82°C).  $\pm 2.0\%$  per 50°F (28°C).  
**Power Requirements:** 12-30 VDC (636), 8-14 VDC (636LP), reverse polarity protection.  
**Output Signal:** 4-20 mA DC, limited to 30 mA DC (636), 1-5 VDC (636LP).  
**Zero & Span Adjustments:** Null: 4.0 mA  $\pm 2\%$  span (636), 1 VDC  $\pm 1\%$  span (636LP); Span: 16.0 mA  $\pm 1\%$  span (636), 4 VDC  $\pm 1\%$  span (636LP).  
**Loop Resistance:** 900  $\Omega$  max @ 30 V.  
**Electrical Connection:** 3/4" female NPT 24" (61 cm), 22 AWG.  
**Process Connection:** 1/2" female NPT.  
**Enclosure Rating:** NEMA 4 (IP56).  
**Weight:** 0.83 lb (374 g).  
**Agency Approvals:** CSA, FM.  
 FM and CSA approved explosion-proof for Class I, Division 1, Groups B, C, & D, Class II Groups E, F, & G Class III.



# INDUSTRIAL WEATHERPROOF PRESSURE TRANSMITTER

Exceptional Reliability for Harsh Environments

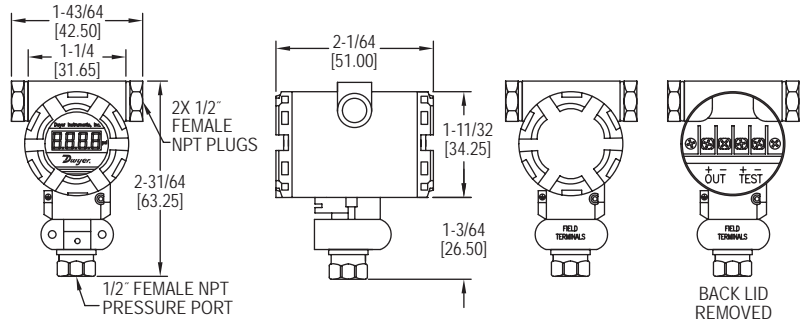

The **Series IWP Industrial Weatherproof Pressure Transmitter** provides an exceptional value solution to pressure measurement in industrial conditions requiring high-performance, stability and long service life. The precise operation under dirty and wet conditions, make the Series IWP an ideal choice for petroleum, chemical and metallurgical industry applications.

**FEATURES/BENEFITS**

- Rugged, weather-proof design supports use in harsh environments

**APPLICATIONS**

- Harsh environments
- Process
- Chemical
- Petroleum
- Metallurgical

**SPECIFICATIONS**

**Service:** Gases and liquids compatible with wetted materials.  
**Wetted Materials:** 304 and 316 stainless steel.  
**Accuracy:** 0.5% FS.  
**Stability:** <0.2% FS per year.  
**Temperature Limits:** -22 to 203°F (-30 to 95°C).  
**Compensated Temperature Limits:** 32 to 158°F (0 to 70°C).  
**Pressure Limits:** 1.5 x pressure range.  
**Temperature Coefficient:** 0.3% FS per 10°C.  
**Power Requirements:** 12-36 VDC.  
**Output Signal:** 4-20mA.  
**Loop Resistance:** 1200 Ω max.  
**Electrical Conduit Connection:** 1/2" female NPT.  
**Process Connection:** 1/2" female NPT.  
**Enclosure Rating:** IP65.

MODEL CHART			
Model	Pressure Range	Model	Pressure Range
IWP-00	0 to 30 psig	IWP-04	0 to 300 psig
IWP-01	0 to 50 psig	IWP-05	0 to 500 psig
IWP-02	0 to 100 psig	IWP-06	0 to 1000 psig
IWP-03	0 to 200 psig	IWP-10	0 to 30 psia

OPTIONS	
Use order code:	Description
NISTCAL-PT1	NIST traceable calibration certificate



SERIES 3200G | MERCROID® BY DWYER



# EXPLOSION-PROOF PRESSURE TRANSMITTER

## HART®, Push-Button Configuration, Rangeability (100:1)

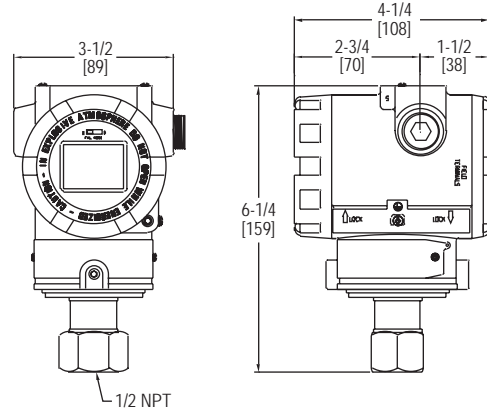

The Mercoid® Series 3200G Explosion-Proof Smart Pressure Transmitter is a microprocessor-based high performance transmitter, which has flexible pressure calibration, push-button configuration, and programmable using HART® Communication. The Series 3200G is capable of being configured with the zero and span buttons, a field calibrator is not required for configuration. The transmitter software compensates for thermal effects, improving performance. EEPROM stores configuration settings and stores sensor correction coefficients in the event of shutdowns or power loss. The Series 3200G is FM approved for use in hazardous (Classified) locations. The 100:1 rangeability allows the smart transmitter to be configured to fit any application.

### FEATURES/BENEFITS

- Completely configurable using zero/span buttons (no calibrator required)
- Rangeability (100:1)
- High accuracy (±0.075%)
- Automatic sensor temperature compensation
- Fail-mode process function

### APPLICATIONS

- Water and wastewater
- Chemical and petrochemical
- Pulp and paper
- Oil and gas
- Food and beverage

### SPECIFICATIONS

**Service:** Compatible gases, steam, liquids or vapors.  
**Wetted Materials:** 316L SS.  
**Accuracy:** ±0.075% FS (@ 20°C).  
**Rangeability:** 100:1 turn down.  
**Stability:** ±0.125% FSO/yr.  
**Temperature Limits:** Process: -40 to 248°F (-40 to 120°C); Ambient: Without LCD -40 to 185°F (-40 to 85°C); With LCD -22 to 176°F (-30 to 80°C).  
**Thermal Effect:** ±0.125% span/32°C.  
**Power Requirements:** 11.9 to 45 VDC.  
**Output Signal:** 4 to 20 mA / HART® Communication.  
**Response Time:** 0.12 s.  
**Damping Time:** 0.25 to 60 s.  
**Loop Resistance:** Operation: 0 to 1500 Ω; HART® Communication: 250 to 500 Ω.  
**Electrical Connection:** Two 1/2" female NPT conduit, screw terminal.  
**Process Connections:** 1/2" female NPT.  
**Display:** Optional 5 digit LCD.  
**Enclosure Rating:** NEMA 4X (IP66) and explosion proof for Class I, Div I Groups A, B, C and D.  
**Weight:** 5.5 lb (2.5 kg).  
**Agency Approvals:** ATEX, CE, FM.

### MODEL CHART

Model	Range psi (kPa)	Calibrated Span (Min. to Max.) psi (kPa)	Max. Pressure psi (bar)	LCD Display
3200G-1-FM-1-1	-14.5 to 21 (-100 to 150)	0.22 to 21 (1.5 to 150)	58 (4)	No
3200G-2-FM-1-1	-14.5 to 217 (-100 to 1500)	2 to 217 (15 to 1500)	580 (40)	No
3200G-3-FM-1-1	0 to 725 (0 to 5000)	7.25 to 725 (50 to 5000)	2000 (138)	No
3200G-4-FM-1-1	0 to 3600 (0 to 25000)	36 to 3600 (250 to 25000)	10000 (690)	No
3200G-5-FM-1-1	0 to 8500 (0 to 60000)	87 to 8700 (600 to 60000)	11600 (800)	No
3200G-1-FM-1-1-LCD	-14.5 to 21 (-100 to 150)	0.22 to 21 (1.5 to 150)	58 (4)	Yes
3200G-2-FM-1-1-LCD	-14.5 to 217 (-100 to 1500)	2 to 217 (15 to 1500)	580 (40)	Yes
3200G-3-FM-1-1-LCD	0 to 725 (0 to 5000)	7.25 to 725 (50 to 5000)	2000 (138)	Yes
3200G-4-FM-1-1-LCD	0 to 3600 (0 to 25000)	36 to 3600 (250 to 25000)	10000 (690)	Yes
3200G-5-FM-1-1-LCD	0 to 8500 (0 to 60000)	87 to 8700 (600 to 60000)	11600 (800)	Yes

**Note:** Contact factory for custom calibration.

### ACCESSORIES

Model	Description
A-630	Stainless steel angle type bracket with SS bolts
A-631	Stainless steel flat type bracket with SS bolts
BBV-0N	2-valve block manifold
DevCom2000	HART® Communication Protocol Software

HART® is a registered trademark of Hart Communication Foundation.

# EXPLOSION-PROOF PRESSURE TRANSMITTER

HART®, Push-Button Configuration, Rangeability (100:1)

MODEL CHART														
Example	3200G	-2	-FM	-3	-1	-LES	S2	A1	05	S	2	-05	-LCD	3200G-2-FM-3-1-LESS2A105S2-05-LCD
Series	3200G													Explosion-proof pressure transmitter
Range		1 2 3 4 5												-14.5 to 21 psig (factory set 0 to 21 psig) -14.5 to 217 psig (factory set 0 to 217 psig) 0 to 725 psig 0 to 3600 psig 0 to 8500 psig
Approval			FM ATEX WP											FM approved ATEX approved Weatherproof only (Only available with 316 SS housing)
Process Connection				1 3										1/2" female NPT Diaphragm seal
Electrical Connection					1									1/2" female NPT
Diaphragm Seal Type						LED LES LFD LFS								1 extended diaphragm seal direct mount 1 extended diaphragm seal capillary type high 1 flush diaphragm seal direct mount 1 flush diaphragm seal capillary type
Mounting Flange							S2 S3							2" (50 mm) 316L SS 3" (80 mm) 316L SS
Mounting Flange Rating								A1 A2 D1 D2 J1 J2						ANSI class 150# ANSI class 300# DIN PN 10/16 DIN PN 25/40 JIS 10 K JIS 20 K
Extension Length									00 05 10 15					No extension (standard for flush mount) 2" extension 4" extension 6" extension
Diaphragm Material										S P H T				316L SS diaphragm PTFE and 316L SS diaphragm Hastelloy C-276 diaphragm Tantalum diaphragm
Fill Fluid											2			Silicon oil (-40 to 400°F)
Capillary Length												XX		0 to 20 feet
Options													LCD SSH NIST CC	5 digit LCD 316 SS housing (only available with WP approval) NIST calibration Custom calibration

CUSTOM CALIBRATION VALUES	
Primary Units	in w.c., ft w.c., mm w.c., in Hg, psig, g/cm <sup>2</sup> , kg/cm <sup>2</sup> , Pa, kPa, bar, mbar, Torr, Atm, mm Hg
Upper Range Limit	20 mA value
Lower Range Limit	4 mA value
Damping Time	0 to 60 seconds
Display Mode	Primary unit, %, mA, rotate

MODEL DEVCOM2000

## HART® COMMUNICATION PROTOCOL SOFTWARE

Includes USB HART Modem

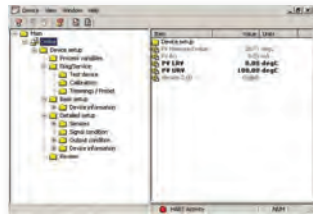

DevCom2000 software



Windows®-based PC

USB HART modem

The Model DEVCOM2000 HART® Communication Protocol Software turns your PC into a full-featured HART® communicator. Now it is possible to configure transmitters and control valves at the desktop or in the field. DevCom2000 uses device descriptions (DDs) to retrieve data that is stored in the memory of smart field devices. This software is a simple, reliable and secure method to add new measurement values to control systems without the need of additional wires. This software eliminates the need to purchase and maintain a separate handheld HART® communicator.

FEATURES/BENEFITS

- Complete DD library
- Includes USB HART modem
- USB 1.1 and 2.0 compatible
- Self powered modem

APPLICATIONS

- For use with pressure transmitters and control-valves in:
  - Water and wastewater
  - Chemical and petrochemical
  - Oil and gas
  - Pulp and paper
  - Food and beverage

MODEL CHART	
Model	Description
COM-PC	DevCom2000 Hart® software and modem

SPECIFICATIONS

**HART® Communicator Software**  
**DD Library:** Included.  
**Generic DD:** Included.  
**Operating System:** Windows NT®, Windows® 2000, Windows XP®, Windows® Vista (32/64), Windows® 7 (32/64).  
**USB HART MODEM**  
**Material:** High strength ABS plastic.  
**Temperature Limits:** 0 to 50°C (32 to 122°F).  
**Storage Temperature:** -40 to 85°C (-40 to 185°F).  
**Humidity:** 0 to 99% (non-condensing).  
**HART® Cable Length:** 4' (1.2 m).

**HART® Cable Connectors:** Mini-grabber.  
**USB Cable Length:** 18" (0.5 m).  
**USB Cable Connector:** USB Type A.  
**USB:** USB 1.1, USB 2.0.  
**Power:** USB port provides power to unit.  
**Current Draw:** 20 mA.  
**Output:** 600 mVpp.  
**Leakage:** < 10 uA.  
**Isolation Voltage:** 1500 VDC.  
**HART®:** HART® 4, HART® 5, HART® 6, HART® 7, HART® Physical Layer Spec HCF\_SPEC-54.  
**Weight:** 3 oz (85 g).  
**Agency Approvals:** CE.

HART® is a registered trademark of Hart Communication Foundation  
 Windows®, Windows NT®, and Windows Vista® are registered trademarks of Microsoft Corporation.

# SMART PRESSURE TRANSMITTER

HART® Communication, Push-Button Configuration, Rangeability (Up to 100:1)

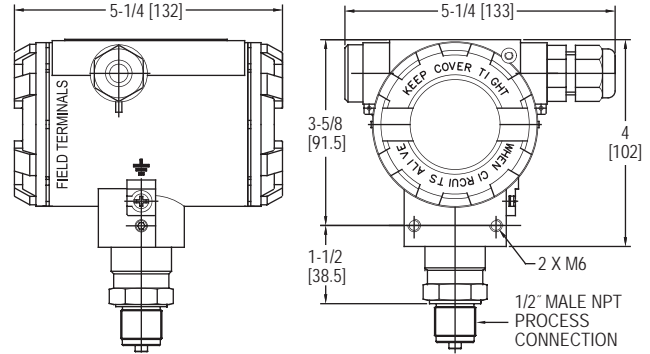

The **Series 3400 Smart Pressure Transmitter** is a microprocessor-based high performance transmitter, which has flexible pressure calibration, push-button configuration, and is programmable using HART® Communication. The Series 3400 is capable of being configured with the zero and span buttons (a field calibrator is not required for configuration). The transmitter software compensates for thermal effects, improving performance. EEPROM stores configuration settings and stores sensor correction coefficients in the event of shutdowns or power loss. The Series 3400 can be configured to be ATEX or IECEx approved for use in hazardous (classified) locations. The rangeability allows the smart transmitter to be configured to fit most applications.

**FEATURES/BENEFITS**

- High accuracy (±0.075% FS)
- Rangeability (up to 100:1)
- Configurable using zero/span buttons (no calibrator required)
- Fail-mode process function
- Automatic ambient temperature compensation

**APPLICATIONS**

- Water and wastewater
- Chemical and petrochemical
- Pulp and paper
- Oil and gas
- Food and beverage

MODEL CHART			
Model	Range	Min. Set Range	Overpressure limit
3400-AL-10-NM-2	0 to 15 psi	1.45 psi	30 psi
3400-AL-13-NM-2	0 to 100 psi	1.45 psi	200 psi
3400-AL-15-NM-2	0 to 350 psi	3.6 psi	725 psi
3400-AL-20-NM-2	0 to 2300 psi	14.5 psi	6525 psi
3400-AL-23-NM-2	0 to 4350 psi	43.5 psi	6525 psi

**Note:** Bar ranges are also available.

**SPECIFICATIONS**

**Service:** Compatible gases, steam, liquids or vapors.  
**Wetted Materials:** 316L SS.  
**Accuracy:** ±0.075% FS (@ 20°C).  
**Rangeability:** Up to 100:1 turn down.  
**Stability:** ≤0.075% FSO/3 years.  
**Temperature Limits:** Ambient: -40 to 185°F (-40 to 85°C); Process with -DS: -40 to 400°F (-40 to 204°C).  
**Thermal Effect:** < ±0.05% span/10°C.  
**Power Requirements:** 10-55 VDC.  
**Output Signal:** 4-20 mA.  
**Response Time:** 16 to 480 ms (programmable).  
**Damping Time:** 0 to 60 s.  
**Electrical Connection:** Packing gland M20x1.5, two 1/2" female NPT conduit, screw terminal.  
**Process Connections:** 1/2" female or male NPT.  
**Enclosure Rating:** NEMA 4X IP66/IP67.  
**Agency Approvals:** CE; -IS, -FP suffix: ATEX Compliant CE 0518 II 2G Ex ia/db IIC T6/T5 Gb Ta<80°C, T5 / II 2D Ex ia/tb IIC T85°C/T100°C Db. Type Certificate No. KDB 17ATEX0056X. ATEX Standards: EN 60079-0:2012+A11:2013, EN 60079-1:2014, EN 60079-11:2012, EN 60079-26:2015, EN 60079-31:2014 IECEx Compliant: Ex ia/db IIC T6/T5 Gb / Ex ia/tb IIC T85°C/T100° Db. Certificate of Conformity IECEx KDB 17.0008X. IECEx Standards: IEC 60079-0:2011, IEC 60079-1:2014-06, IEC 60079-11:2011, IEC 60079-26:2006, IEC 60079-31:2013.



# SMART PRESSURE TRANSMITTER

HART® Communication, Push-Button Configuration, Rangeability (Up to 100:1)

MODEL CHART											
Example	3400	-AL	-01	-DS	-1	-SPD	A	0	-1	-NIST	3400-AL-01-DS-1-SPDA0-1-NIST
Series	3400										Single pressure smart transmitter
Housing		AL AS									Aluminum housing Stainless steel housing
Range			01 03 05 07 10 11 13 15 17 20 23 26 29								0 to 18 psia 0 to 100 psia 0 to 350 psia 0 to 1000 psia 0 to 15 psi 0 to 30 psi 0 to 100 psi 0 to 350 psi 0 to 1000 psi 0 to 2300 psi 0 to 4350 psi 0 to 8700 psi 0 to 14500 psi
Process Connections				NM NF DS							1/2" male NPT 1/2" female NPT Diaphragm seal selection
Electrical Connections					1 2						Packing gland M20x1.5 Thread 1/2" female NPT
Diaphragm Seal Type						SPD SPR STD STR					S-P flush diaphragm seal direct mount S-PK flush diaphragm seal capillary mount S-T extended diaphragm seal direct mount S-TK extended diaphragm seal capillary mount
Mounting Flange							A B C D				2" ANSI 2" DN50 3" ANSI 3" DN80
Extension Length								0 2 4 6			No extension, flush mount 2" (50 mm) 4" (100 mm) 6" (150 mm)
Capillary Length									#		Capillary length, 1 to 20 ft (increments of 1)
Options										FP IS MT NIST GM SM ST	ATEX/IECEX flameproof ATEX/IECEX intrinsically safe Stainless steel tag plate mounted on wire NIST traceable calibration certificate 2" galvanized steel mounting bracket 2" SS mounting bracket Stainless steel plate riveted to the housing

ACCESSORIES	
Model	Description
A-630	Stainless steel angle type bracket with SS bolts
A-631	Stainless steel flat type bracket with SS bolts
BBV-0N	2-valve block manifold
DevCom2000	HART® communication protocol software

# INTRINSICALLY SAFE PRESSURE TRANSMITTERS

## For Use In Hazardous Locations

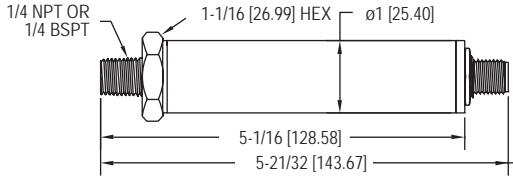

**Male NPT/BSPT connector with male M-12 connector**

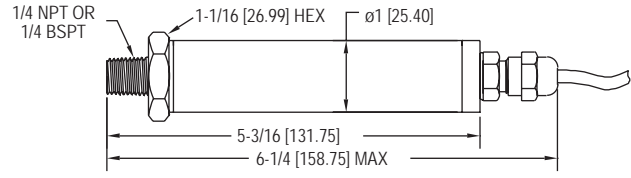

**Male NPT/BSPT connector with cable gland**

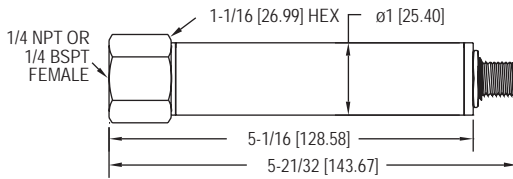

**Female NPT/BSPT connector with male M-12 connector**

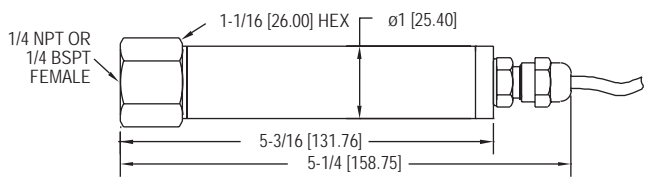

**Female NPT/BSPT connector with cable gland**



The Dwyer **Series IS626 Intrinsically Safe Pressure Transmitters** can be used to accurately measure compatible gases and liquids compatible with its 316/316L stainless steel wetted parts. Series IS626 full-scale accuracy is 0.25%. Designed for industrial environments with a NEMA 4X (IP66) housing, this transmitter resists most effects of shock and vibration. Models are available with a 3' cable or M-12 4 pin connection.

The IS626 is UL listed for use in Hazardous (Classified) Locations. The protection method is by Intrinsic Safety, "ia". It was investigated by UL under UL Standard 913 Sixth Edition and CSA Standard No. 157-92.

**FEATURES/BENEFITS**

- Exceptional accuracy for insuring tight-control and minimizing costly out of specification conditions
- NEMA 4x rated enclosure provides protection in harsh environments permitting outdoor monitoring or in areas where dust and particulate matter exists
- Robust sensor provides shock and vibration resistance insuring stability in controlling pressure for process applications

**APPLICATIONS**

- Monitoring pressure in hazardous environments
- Process

**SPECIFICATIONS**

- Service:** Compatible gases and liquids.
- Wetted Materials:** Type 316, 316L SS.
- Accuracy:** 0.25% FS.
- Temperature Limit:** 0 to 176°F (-18 to 80°C).
- Compensated Temperature Range:** 0 to 176°F (-18 to 80°C).
- Thermal Effect:** ±0.02% FS/°F (includes zero and span).
- Pressure Limits:** See Pressure Range Table.
- Power Requirements:** 10-28 VDC.
- Output Signal:** 4-20 mA.
- Response Time:** 50 ms.
- Loop Resistance:** 0-900 Ω max.
- Current Consumption:** 38 mA (max).
- Electrical Connections:** 3 ft cable or 4-pin M-12 connector.
- Process Connection:** 1/4" male or female NPT and BSPT.
- Enclosure Rating:** NEMA 4X (IP66).
- Mounting Orientation:** Mount in any position.
- Weight:** 8.9 oz (252 g).
- Agency Approvals:** CE, cULus Intrinsically Safe to UL Standard 913.

**For use in Hazardous (Classified) Locations:**

- Class I Div. 1 Groups A,B,C,D**
- Class II Div. 1 Groups E,F,G**
- Class III Div. 1**
- Temperature Code:** T4 @ 80°C ambient
- Install in accordance with control drawing 01-700797-00.**
- WARNING** To prevent ignition of flammable or combustible atmospheres, disconnect power before servicing.
- Use with approved safety barriers using entity evaluation.**

MODEL CHART			
Model	Range	Maximum Pressure (psig)	Over Pressure (psig)
IS626-07-GH-P1-E1-S1	15 psig	30	150
IS626-08-GH-P1-E1-S1	30 psig	60	300
IS626-09-GH-P1-E1-S1	50 psig	100	300
IS626-10-GH-P1-E1-S1	100 psig	200	500
IS626-11-GH-P1-E1-S1	150 psig	300	750
IS626-12-GH-P1-E1-S1	200 psig	400	1000
IS626-13-GH-P1-E1-S1	300 psig	600	1500
IS626-14-GH-P1-E1-S1	500 psig	1000	2500

**Note:** For optional M-12 4 pin electrical connection, change E1 to E6.

OPTIONS	
To order add suffix:	Description
-NIST	NIST traceable calibration certificate
Example: IS626-07-GH-P1-E1-S1-NIST	

ACCESSORIES	
Model	Description
A-295	Female four pin M-12 to cable gland connector
A-231	16' (5 m) shielded cable with 4 pin female M-12 connection
MTL5541	Galvanic barrier
MTL7706	Intrinsically safe zener barrier

**SELECTION GUIDE**  
pages 112-113

**TYPICAL APPLICATIONS**  
pages 114-115

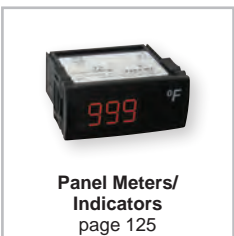
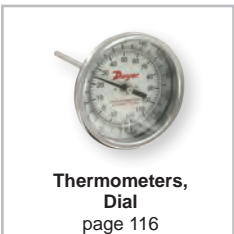

## FEATURED PRODUCTS

### LOW LIMIT FREEZE PROTECTION SWITCH SERIES DFS2 | page 131







- (2) SPDT switch contacts allowing for shutdown of equipment and alarming building management system
- Automatic or manual reset action and 10 foot or 20 foot capillary lengths to meet multiple application needs

### TEMPERATURE TRANSMITTER MODEL TBU-00 | page 134





- Universal sensor input for thermocouples, RTDs, thermistors, or mV voltage sensors
- Downloadable software allowing for custom ranging of output signal

**Dwyer****DIAL**  
Thermometers

					
<b>SERIES</b>	<b>BT</b> - page 116	<b>BTLRN</b> - page 116	<b>ITA</b> - page 117	<b>RRT3</b> - page 118	<b>BTO</b> - page 118
<b>Range</b>	0 to 1000°F	0 to 200°F	-40 to 550°F	-40 to 300°F	0 to 550°F
<b>Dial Size</b>	2", 3" or 5"	3"	9" liquid filled linear scale	3-1/2" with set point and SPDT output	3" or 5" with 4-20 mA temperature output
<b>Stem Length</b>	2.5", 4" or 6"	12" to 72"	2-1/2" or 5" thermowell	3-1/8" remote stem with 10.5" capillary	2-1/2", 4", 6", 9", or 12"
<b>Process Connection</b>	1/2" NPT; Back, Lower, or Adjustable mount	1/2" NPT; Back mount	3/4" NPT; Adjustable lower mount	1/2" NPT; Remote mount	1/2" NPT; Adjustable mount

**LIMIT CONTROL**  
Digital Temperature Switches





			
<b>SERIES</b>	<b>16L</b> - page 125	<b>TSF-DF</b> - page 126	<b>TSF</b> - page 126
<b>Number of Temperature Units</b>	1	1	1
<b>Temperature Input Type</b>	Thermocouple, RTD, voltage, or current	Type J, K, or S thermocouple	Type J, K, or S thermocouple
<b>Digital Input</b>	No	Yes	Yes
<b>Number of Relay Outputs</b>	1 or 2	1	1
<b>Relay Type</b>	2 SPST, 1 SPDT	SPST	SPDT
<b>Approvals</b>	FM, UL	CE, UL	CE, FM, UL

These Selection Guides are for quick comparison of similar products. Please refer to the catalog page number referenced for complete product information and specifications.



# PID LOOP CONTROLLERS

## Temperature and Process Controllers

				
<b>SERIES</b>	<b>16C, 8C, 4C</b> - page 119	<b>32B, 16B, 8B, 4B</b> - pages 120-121	<b>16G, 8G, 4G</b> - pages 122-123	<b>SCD</b> - page 124
<b>Number of Temperature Inputs</b>	1	1	1	1 to 8
<b>Temperature Input Type</b>	Thermocouple or RTD	Thermocouple, RTD, current, or voltage	Thermocouple, RTD, current, or voltage	Thermocouple, RTD, current, or voltage
<b>DIN Sizes</b>	1/16, 1/8, 1/4	1/32, 1/16, 1/8, 1/4	1/16, 1/8, 1/4	DIN rail mount
<b>Number of Outputs</b>	1	2	2	2 to 16
<b>Output Type</b>	SPDT mechanical relay 14 VDC pulse voltage 4 to 20 mA current	SPDT mechanical relay 14 VDC pulse voltage 4 to 20 mA current 0 to 10 VDC voltage	SPDT mechanical relay 14 VDC pulse voltage 4 to 20 mA current 0 to 10 VDC voltage	SPDT mechanical relay 14 VDC pulse voltage 4 to 20 mA current 0 to 10 VDC voltage
<b>Approvals</b>	CE, UL	CE, UL	CE, UL	CE, UL

# HEATING & COOLING/REFRIGERATION CONTROL

## Digital Temperature Switches

						
<b>SERIES</b>	<b>40T &amp; 40M</b> - page 127	<b>TCS</b> - page 127	<b>TST &amp; TS2</b> - page 128 & 129	<b>TSXT</b> - page 128	<b>TSS2</b> - page 129	<b>TSW</b> - page 130
<b>Number of Temperature Units</b>	1	1	1	3	2	1 or 2
<b>Temperature Input Type</b>	40T: Type J or K thermocouple, 2 or 3 wire PT 100 RTD; 40M: Thermocouple, RTD, thermistor, current, or voltage	Type J, K, or S thermocouple	TST: PTC or NTC thermistor; TS2: PTC	PTC or NTC thermistor	PTC or NTC thermistor	PTC or NTC thermistor
<b>Digital Input</b>	No	No	No	Yes	No	No
<b>Number of Relay Outputs</b>	1	1	2	1, 2, or 3	2	1 or 2
<b>Relay Type</b>	SPDT	SPDT	SPDT	1 output models: SPDT 2 & 3 output models: SPST	SPDT	SPDT
<b>Approvals</b>	CE, UL	CE, UL	CE, cURus	CE, cURus	CE, cURus	CE, cURus

These Selection Guides are for quick comparison of similar products. Please refer to the catalog page number referenced for complete product information and specifications.



**Environmental chamber control simplified with digital zone control.**

Environmental chambers have traditionally used separate controls to handle the temperature and relative humidity control tasks. The Love Controls® 32DZ dual zone control with Love® 5000 Series RTD and Dwyer® RH Humidity transmitter controls both parameters in a single small format (1/32 DIN) control to handle both zones, simplifying wiring and reducing panel costs. The 32DZ can switch small resistive loads directly or, when used with Dwyer® Series 62 solid state relays (not shown), can switch larger loads.

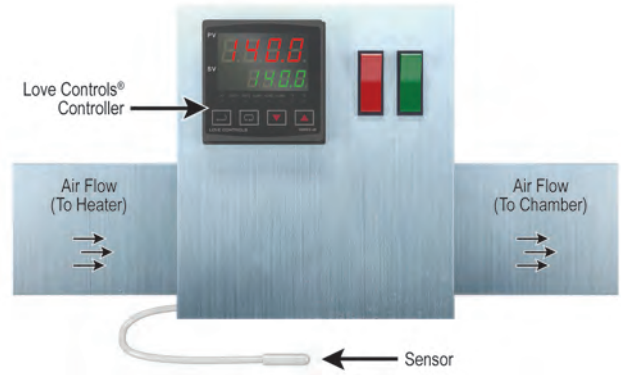

**Dwyer® controllers used within heater controllers.**

In bioscience laboratories, the preferred methods of temperature control for experiments are heated water baths. There are experiments where water cannot be used, so the next feasible option is to send temperature controlled air to the experiment site. In order to use temperature controlled air, an air heater is needed. Within this product, a Love Controls® temperature controller is used for accurate and responsive temperature control. The Love Controls® controller can adapt to a different environment through different operating modes such as SELF-TUNE or manual PID adjustments, or preset PID responses.

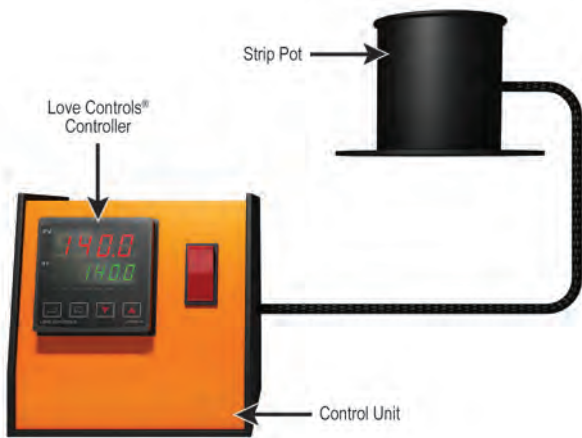

**Love Controls® controllers involved in insulation removal.**

For most wires, removing the insulation is easy, but for magnetic and enamel wires, removing the insulation is very difficult. One way to easily remove the insulation of the magnetic or enamel wire is to dip them in a solution of molten fused salts. The salts are heated to a temperature high enough to melt the salts into a liquid, but not deteriorate them. This process uses a Love Controls® feedback temperature controller. The Love Controls® controller allows the operator to input a desired temperature and maintain that temperature accurately. The Love Controls® controller will also retain the input temperature after the power is disconnected.



**Series TS Digital Temperature Switches regulate temperature in refrigerated and display cases.**

When storing food or other perishables in chillers or display cases, temperature must be carefully regulated to ensure the products remain fresh. If the storage area rises above the critical preservation temperature, products can have their shelf life dramatically shortened or be spoiled altogether. A Dwyer® Series TSX3 Digital Temperature Switch will prevent these scenarios by monitoring temperature and activating refrigeration and defrost cycles to ensure the storage temperature stays within safe limits.

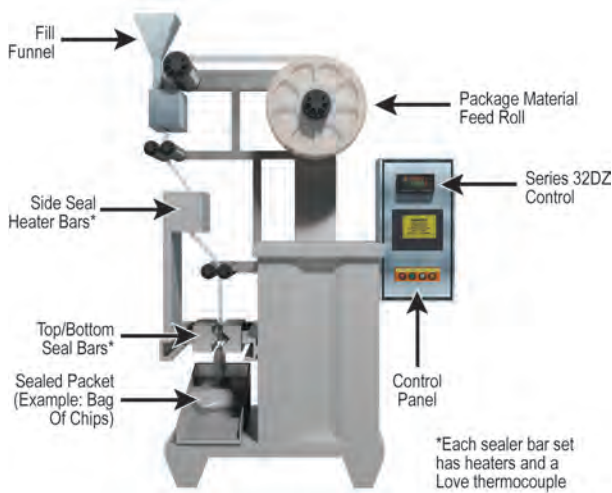

**Form, fill and seal machine control simplified with dual zone control.**

Form, fill and seal machines traditionally have used separate controls to handle the temperature control requirement for the side and top/bottom seal bars. The Love Controls® 32DZ with Love® 5000 Series thermocouples allows for a single small format (1/32 DIN) control to handle both zones, simplifying wiring and reducing panel costs. The 32DZ can switch small resistive loads directly or, when used with the Love® 62 Series solid state relays (not shown), can switch larger loads.



**Love Controls® controllers used in the packaging of condiments.**

Packaging of condiments require the sealing bars to be heated to a temperature hot enough to seal the packages, but not destroy the packaging material. The heat on the sealing bars needs to be controlled to ensure the heat does not become excessive. Love Controls® controllers are used in this process to accurately control the heat on the sealing bars. The sensors from the Love Controls® controllers are placed on the sealing bars to ensure accurate temperature readings. Should the heat become excessive, an alarm light on the controller notifies the operator of the impending conditions.



**Resin transfer molding.**

Accurate control of temperature and epoxy resin flow is important during resin transfer molding. For the epoxy resin to have an even and thorough flow, the resin must be at a temperature high enough to allow it to flow, yet not burn the resin. With the help of a Love Controls® controller, the temperature of the resin is accurately controlled under different conditions through the different PID operating modes. Another Love Controls® controller, with a flow transducer, is used in this process to control the flow of the epoxy resin. The Love Controls® controller provides information on the temperature and flow rate to the computer through an RS-485 serial communication option.

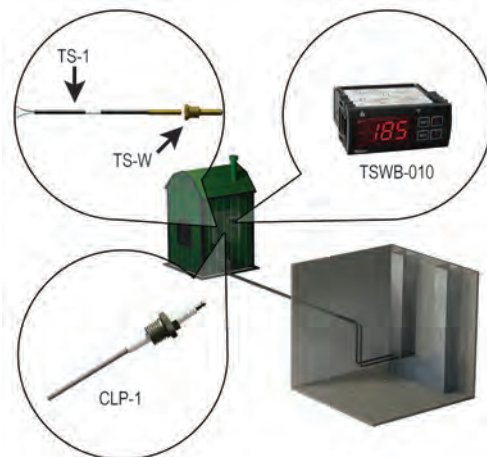

**Controlling water temperature in outdoor wood furnace.**

The Series TSWB is the ideal control for monitoring water temperature and water level in outdoor wood furnaces. The Series TSWB controls the damper and/or the fan that provides oxygen to the flame in the fire box. Usually an external light will also be controlled by the Series TSWB to inform the user that the furnace is out of wood or that the water level is low. The TSWB accepts thermistor inputs for temperature and conductivity probe, Dwyer CLP-1, inputs for monitoring water level.

**Dwyer**  
SERIES BT

# BIMETAL THERMOMETER

2", 3" or 5" Dial, Dual Scale, ±1% FS Accuracy, External Reset

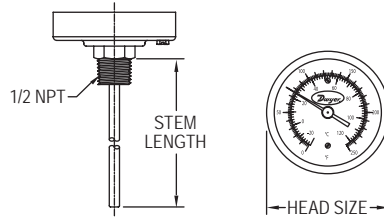

Back connection

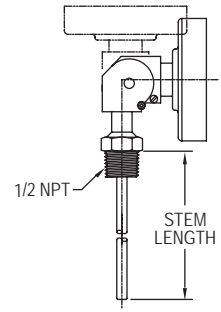

Adjustable angle connection

The **Series BT Bimetal Thermometer** offers accurate, reliable service even in the toughest environments. These corrosion resistant units are constructed from stainless steel and are hermetically sealed to prevent crystal fogging.

**FEATURES/BENEFITS**

- Hermetically sealed
- Adjustable dial position models

**APPLICATIONS**

- Chiller or boiler water temperature monitoring
- Treatment plant temperature monitoring

**SPECIFICATIONS**

**Wetted Materials:** 304 SS.  
**Housing Material:** Series 300 SS.  
**Lens:** Glass.  
**Accuracy:** ±1% full-scale.  
**Response Time:** ≤ 40 s.  
**Temperature Limits:** Head: 200°F (93°C); Stem: Not to exceed 50% over-range or 1000°F (538°C) or 800°F (427°C) continuously.  
**Process Connection:** 1/4" NPT on 2" dial size; 1/2" NPT on 3" or 5" dial size.  
**Stem Diameter:** 1/4" OD.  
**Immersion Depth:** Minimum 2" in liquids, 4" in gas.

**MODEL CHART**

Model	Dial Size	Stem Length	Connection	Range °F (°C)	Degree Div °F (°C)	Model	Dial Size	Stem Length	Connection	Range °F (°C)	Degree Div °F (°C)
BTB22551*	2"	2-1/2"	Back	0 to 250	2	BTB3605D	3"	6"	Back	0 to 250 (-20 to 120)	2 (2)
BTB2405D	2"	4"	Back	0 to 250 (-20 to 120)	2 (2)	BTA54010D	5"	4"	Adjustable	0 to 200 (-20 to 100)	2 (2)
BTB2409D	2"	4"	Back	200 to 1000 (100 to 550)	10 (5)	BTA5405D	5"	4"	Adjustable	0 to 250 (-20 to 120)	2 (2)
BTB32510D	3"	2-1/2"	Back	0 to 200 (-20 to 100)	2 (2)	BTA5407D	5"	4"	Adjustable	50 to 550 (10 to 290)	5 (5)
BTB3255D	3"	2-1/2"	Back	0 to 250 (-20 to 120)	2 (2)	BTA56010D	5"	6"	Adjustable	0 to 200 (-20 to 100)	2 (2)
BTB3257D	3"	2-1/2"	Back	50 to 550 (10 to 290)	5 (5)	BTA5605D	5"	6"	Adjustable	0 to 250 (-20 to 120)	2 (2)
BTB34010D	3"	4"	Back	0 to 200 (-20 to 100)	2 (2)	BTA5607D	5"	6"	Adjustable	50 to 550 (10 to 290)	5 (5)
BTB3405D	3"	4"	Back	0 to 250 (-20 to 120)	2 (2)	BTC3255D	3"	2-1/2"	Lower	0 to 250 (-20 to 120)	2 (2)
BTB3407D	3"	4"	Back	50 to 550 (10 to 290)	5 (5)						

\*Model offered in Fahrenheit scale only.

**SERIES BTLRN**

# LONG REACH BIMETAL THERMOMETER

Extra-long Stems Reach Remote Areas, Gripping Handle Available

Thermometers, Dial

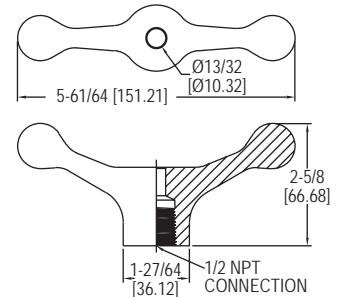
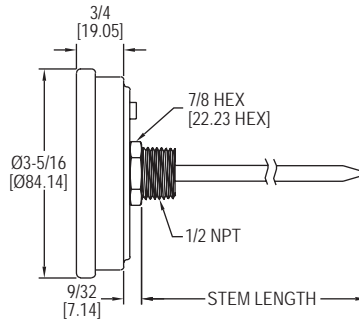

The **Series BTLRN Long Reach Bimetal Thermometer** reaches areas that other thermometers can't. A gripping handle is available as an accessory to comfortably hold the thermometer during temporary installations.

**FEATURES/BENEFITS**

- Stem lengths from 12" to 72"

**APPLICATIONS**

- Large container monitoring
- Duct temperature measurement

**SPECIFICATIONS**

**Wetted Materials:** 304 SS.  
**Housing Materials:** Series 300 SS.  
**Lens:** Glass.  
**Accuracy:** ±1%.  
**Temperature Limits:** Ambient: -40 to 392°F (-40 to 200°C).  
**Dial Size:** 3".  
**Process Connection:** 1/2" NPT.  
**Resolution:** 2°F (1°C).  
**Weight:** 1.0 lb (0.45 kg).

**MODEL CHART**

Model	Stem Length	Range*
BTLRN312101	12"	0 to 200°F
BTLRN318101	18"	0 to 200°F
BTLRN324101	24"	0 to 200°F
BTLRN336101	36"	0 to 200°F
BTLRN348101	48"	0 to 200°F
BTLRN360101	60"	0 to 200°F
BTLRN372101	72"	0 to 200°F

\*Dual scale units available by changing last digit to D. Example: BTLRN31210D

**ACCESSORIES**

Model	Description
BTLR-GH	Gripping handle



# INDUSTRIAL THERMOMETER

## 9" Scale, Adjustable Angle Stem

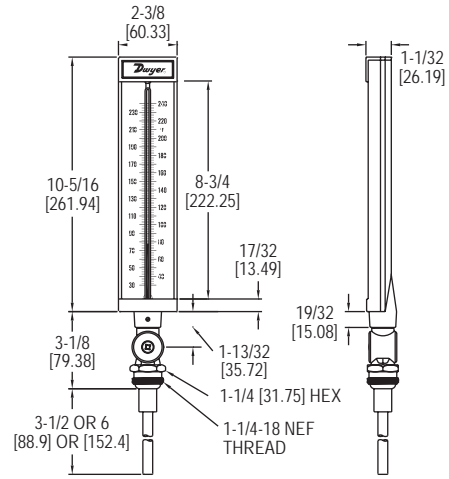

The **Series IT Industrial Thermometer** allows users to easily take accurate temperature measurements in any environment. The case of the IT series is made of die cast aluminum for extra durability in industrial environments.

### FEATURES/BENEFITS

- Organic, non-toxic fill fluid
- Dual scale in °F and °C
- Adjustable stem angle

### APPLICATIONS

- Boiler or chiller temperature monitoring

MODEL CHART			
3-1/2" Stem Model	Range	6" Stem Model	Range
ITA9351D	-40 to 110°F (-40 to 43°C)	ITA9601D	-40 to 110°F (-40 to 43°C)
ITA9352D	0 to 120°F (-17 to 49°C)	ITA9602D	0 to 120°F (-17 to 49°C)
ITA9353D	0 to 160°F (-17 to 71°C)	ITA9603D	0 to 160°F (-17 to 71°C)
ITA9354D	20 to 180°F (-6 to 82°C)	ITA9604D	20 to 180°F (-6 to 82°C)
ITA9355D	30 to 240°F (0 to 114°C)	ITA9605D	30 to 240°F (0 to 114°C)
ITA9356D	30 to 300°F (-1 to 149°C)	ITA9606D	30 to 300°F (-1 to 149°C)
ITA9357D	50 to 400°F (10 to 240°C)		
ITA9358D	50 to 550°F (10 to 288°C)		

### SPECIFICATIONS

**Wetted Material:** Tapered cast aluminum with graphite fill.

**Housing Material:** 9" (228 mm)

**Lens:** Glass.

**Accuracy:** 1% accuracy.

**Scales:** Aluminum painted white with black markings.

**Process Connection:** 1-1/4-18 NEF thread.

**Liquid Filling:** Organic blue liquid filled tube.

**Mounting:** Adjustable stem: Vertical plane 180° horizontal plane 360°.

**Weight:** 1 lb 7 oz (0.65 kg).

### SERIES IT-W

# INDUSTRIAL THERMOMETER THERMOWELLS

## Fits IT Thermometers with 3-1/2" and 6" Stem Lengths

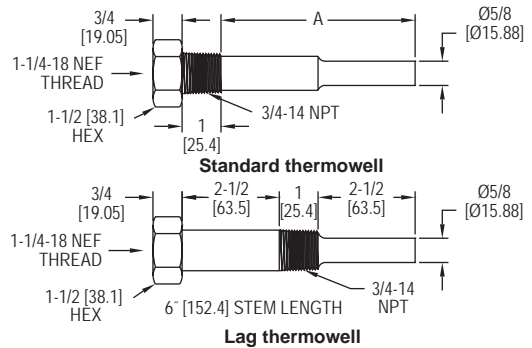

The **Series IT-W Industrial Thermometer Thermowells** reduce installation cost and time by eliminating the need to drain the system when servicing industrial thermometers. The thermowells protect industrial thermometers from high pressure, flow and corrosive media.

### FEATURES/BENEFITS

- Designed to fit the Series IT industrial thermometers
- Lag stems available

### APPLICATIONS

- Boiler or chiller temperature monitoring

MODEL CHART			
Model	Material	Insertion Length	Lag
IT-W01	Brass	2-1/2"	N/A
IT-W11	304 SS	2-1/2"	N/A
IT-W21	316 SS	2-1/2"	N/A
IT-W04	Brass	5"	N/A
IT-W14	304 SS	5"	N/A
IT-W24	316 SS	5"	N/A
IT-W07	Brass	2-1/2"	2-1/2"
IT-W17	304 SS	2-1/2"	2-1/2"
IT-W27	316 SS	2-1/2"	2-1/2"

USA: California Proposition 65

⚠WARNING: Cancer and Reproductive Harm - [www.P65Warnings.ca.gov](http://www.P65Warnings.ca.gov)

# BIMETAL THERMOMETER WITH TRANSMITTER OUTPUT

Bimetal Stem with 4-20 mA Output, 3" or 5" Dial

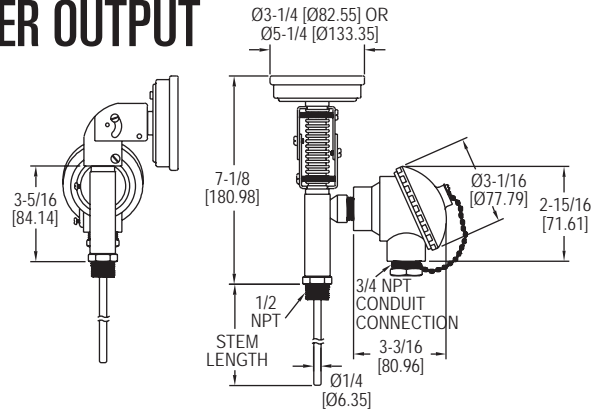

The **Series BTO Bimetal Thermometer with Transmitter Output** eliminates the need for a separate thermometer and transmitter.

**FEATURES/BENEFITS**

- Thermometer and transmitter in one device
- Weatherproof construction

**APPLICATIONS**

- Boilers
- Compressors
- Thermal oxidizers

**SPECIFICATIONS**

**THERMOMETER SPECIFICATIONS**  
**Wetted Materials:** 304 SS.  
**Housing Material:** 304 SS.  
**Lens:** Glass.  
**Accuracy:** ±1% FS.  
**Temperature Limits:** Ambient: -58 to 185°F (-50 to 85°C).  
**Dial Size:** 3" or 5".  
**Process Connection:** 1/2" NPT.  
**Resolution:** 2°F (5°F for 400°F and 550°F models).  
**Weight:** 1.95 lb.

**TRANSMITTER SPECIFICATIONS**  
**Temperature Limits:** Ambient: -58 to 185°F (-50 to 85°C).  
**Power Requirement:** 10-33 VDC.  
**Output Signal:** 4-20 mA.  
**Loop Resistance:** 1045 Ω.  
**Power Consumption:** 38 mA.  
**Enclosure Rating:** NEMA 4X (IP66).

**MODEL CHART**

Model	Dial Size	Stem Length	Range	Model	Dial Size	Stem Length	Range
BTO32551	3"	2.5"	0 to 250°F	BTO52551	5"	2.5"	0 to 250°F
BTO32571	3"	2.5"	50 to 550°F	BTO52571	5"	2.5"	50 to 550°F
BTO34051	3"	4"	0 to 250°F	BTO54051	5"	4"	0 to 250°F
BTO34071	3"	4"	50 to 550°F	BTO54071	5"	4"	50 to 550°F
BTO36051	3"	6"	0 to 250°F	BTO56051	5"	6"	0 to 250°F
BTO36071	3"	6"	50 to 550°F	BTO56071	5"	6"	50 to 550°F
BTO39051	3"	9"	0 to 250°F	BTO59051	5"	9"	0 to 250°F
BTO39071	3"	9"	50 to 550°F	BTO59071	5"	9"	50 to 550°F
BTO31251	3"	12"	0 to 250°F	BTO51251	5"	12"	0 to 250°F
BTO31271	3"	12"	50 to 550°F	BTO51271	5"	12"	50 to 550°F

**Note:** -40 to 160°F, 0 to 200°F, 50 to 300°F, and 50 to 400°F ranges available, contact factory for more information.

USA: California Proposition 65

⚠WARNING: Cancer and Reproductive Harm - www.P65Warnings.ca.gov

Thermometers with Transmitter/Switch

**SERIES RRT3**

# REMOTE READING THERMOMETER WITH SWITCH

SPDT Relay, Liquid Actuated Bulb and Capillary

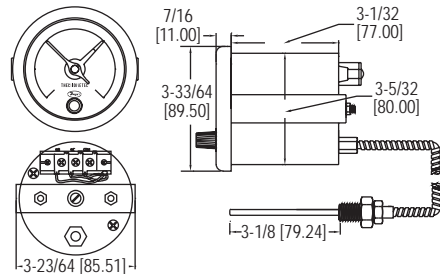

The **Series RRT3 Remote Reading Thermometer with Switch** combines an easy to read 3-1/4" dual scale dial thermometer and a SPDT relay. Color coordinated pointers display the current process temperature and set point.

**FEATURES/BENEFITS**

- Quick connect electrical terminals
- Industrial armored capillary

**APPLICATIONS**

- High temp shut down in process applications
- Boiler or chiller control

**SPECIFICATIONS**

**Wetted Materials:** 304 SS.  
**Accuracy:** ±3% FS.  
**Housing Material:** 304 SS.  
**Temperature Limit:** -4 to 158°F (-20 to 70°C).  
**Switch Type:** SPDT.  
**Electrical Ratings:** 3 A @ 250 VAC, .2 A @ 250 VDC.  
**Electrical Connections:** Screw terminal.  
**Process Connection:** 1/2" (12.7 mm) male NPT.  
**Dial Size:** 3-1/2" (90 mm).  
**Capillary Length:** 10.5" (3.2 m).  
**Bulb Length:** 3-1/8" (79.24 mm).  
**Weight:** 2 lb (900 g).

**MODEL CHART**

Model	Temperature Ranges
RRT3120U	-40 to 120°F (-40 to 50°C)
RRT3250U	32 to 248°F (0 to 120°C)
RRT3300U	0 to 300°F (-18 to 149°C)

USA: California Proposition 65

⚠WARNING: Cancer and Reproductive Harm - www.P65Warnings.ca.gov

# TEMPERATURE LOOP CONTROLLERS

Universal Temperature Input, Single Control Output, RS-485 Communication



16C

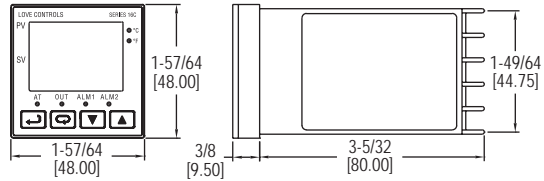

16C



8C

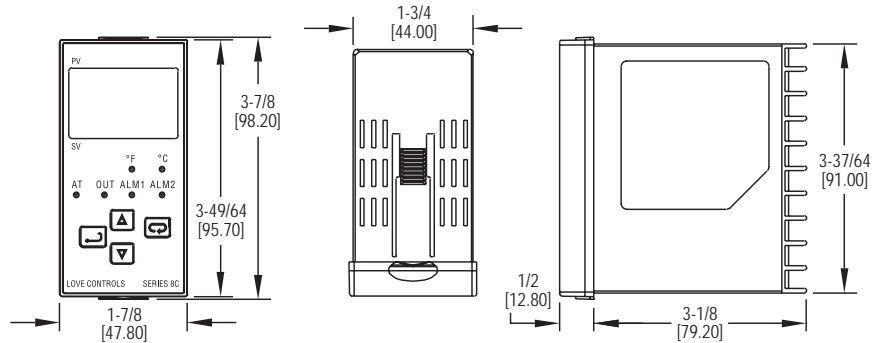

8C



4C

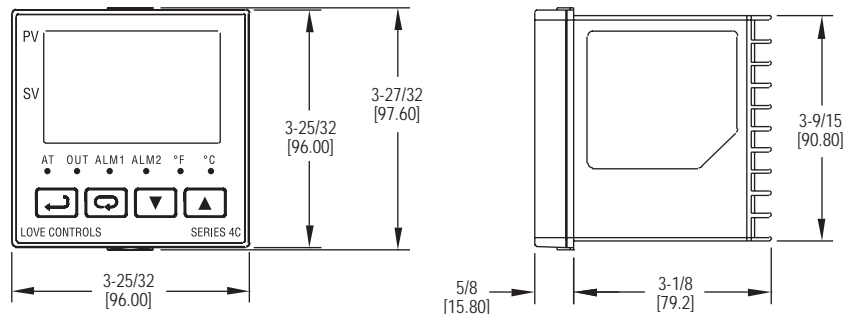

4C

The **Series 16C, 8C, & 4C Temperature Loop Controllers** offer advanced control features for the most demanding temperature or process applications. Offered in 3 standard DIN cutout housing sizes, these controllers are designed with dual, 4 digit LED displays for local indication of the process value, set point, and output conditions.

**FEATURES/BENEFITS**

- Universal input accepts RTD or thermocouple sensors
- On/Off, PID, or manual output control
- RS-485 standard on all models

**APPLICATIONS**

- Oven, boiler, or chiller control
- Hot plates/melt pots
- Food service equipment
- Environmental chambers
- Packaging equipment

MODEL CHART	
Model	Output
16C-2	Voltage pulse
16C-3	Relay
16C-5	Current

MODEL CHART	
Model	Output
8C-2	Voltage pulse
8C-3	Relay
8C-5	Current

MODEL CHART	
Model	Output
4C-2	Voltage pulse
4C-3	Relay
4C-5	Current

ACCESSORIES	
Model	Description
MN-1	Mini-Node™ RS-485 to USB converter
SCD-SW	Configuration software
A-600	R/C snubber

**SPECIFICATIONS**

**Inputs:** Thermocouple or RTD.  
**Display:** Two 4 digit, 7 segment LED's. PV: Red, SV: Green.  
**Accuracy:** ±0.25% of span, ±1 least significant digit.  
**Power Requirements:** 100 to 240 VAC, 50/60 Hz.  
**Power Consumption:** 5 VA max.  
**Operating Temperature:** 32 to 122°F (0 to 50°C).  
**Memory Backup:** Nonvolatile memory.  
**Control Output Ratings:** Relay: SPST, 5 A @ 250 VAC resistive for 16C; SPDT, 5 A @ 250 VAC resistive for 8C and 4C; Voltage Pulse: 14 VDC (max. 40 mA); Current: 4 to 20 mA.  
**Communication:** RS-485 Modbus® ASCII communication protocol.  
**Weight:** 4 oz (114g) for 16C, 15 oz (425g) for 8C and 4C.  
**Front Panel Rating:** IP56.  
**Agency Approvals:** CE, cULus.

INPUT RANGES	
Input Types	Range
K Type TC	-328 to 2372°F (-200 to 1300°C)
K Type TC	-328 to 932°F (-200 to 500°C)
J Type TC	-148 to 2192°F (-100 to 1200°C)
J Type TC	-4 to 752°F (-20 to 400°C)
T Type TC	-328 to 752°F (-200 to 400°C)
T Type TC	4 to 752°F (-20 to 400°C)
E Type TC	32 to 1112°F (0 to 600°C)
N Type TC	-328 to 2372°F (-200 to 1300°C)
R Type TC	32 to 3092°F (0 to 1700°C)
S Type TC	32 to 3092°F (0 to 1700°C)
B Type TC	212 to 3272°F (100 to 1800°C)
L Type TC	-328 to 932°F (-200 to 500°C)
U Type TC	-328 to 1472°F (-200 to 800°C)
Pt 100 RTD	-328 to 1112°F (-200 to 600°C)
Pt 100 RTD	-4 to 932°F (-20 to 500°C)
Pt 100 RTD	32 to 212°F (0 to 100°C)

Modbus® is a registered trademark of Schneider Automation, Inc.

# TEMPERATURE/PROCESS LOOP CONTROLLERS

Universal Input, Dual Control Output, RS-485 Communication



32B

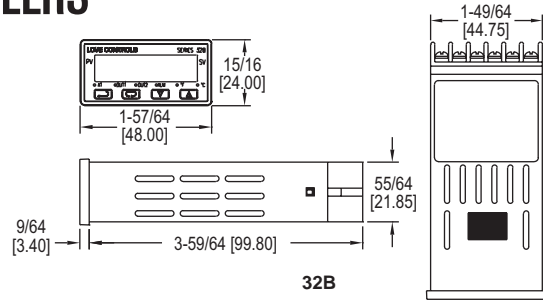

32B



16B

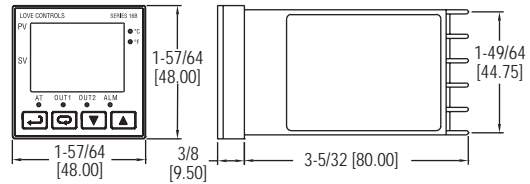

16B



8B

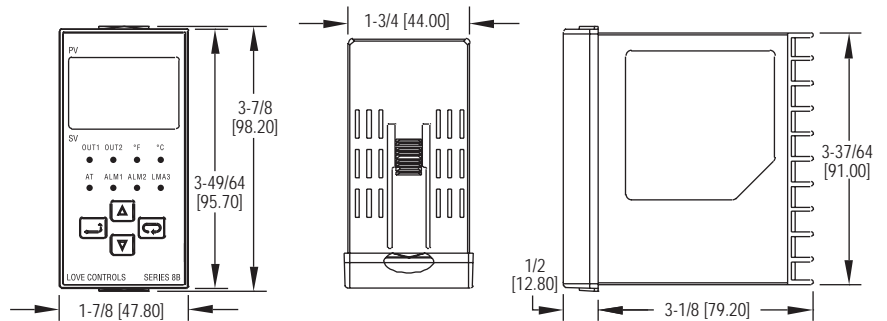

8B



4B

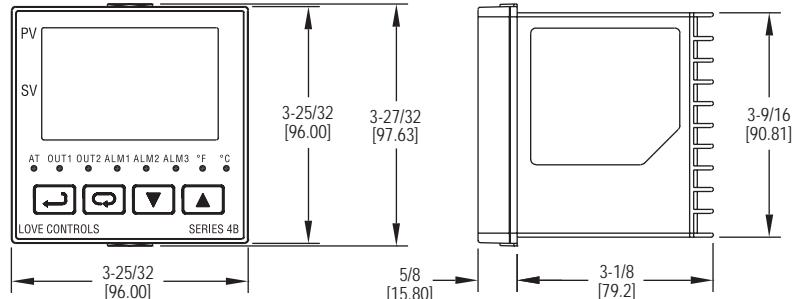

4B

The **SERIES 32B, 16B, 8B, & 4B Temperature/Process Loop Controllers** offer advanced control features for the most demanding temperature or process applications. Offered in 4 standard DIN cutout housing sizes, these controllers are designed with dual, 4 digit LED displays for local indication of the process value, set point, and output conditions.

**FEATURES/BENEFITS**

- Universal input accepts process transmitters, RTD's or thermocouple signals
- On/off, PID, or manual output control
- RS-485 standard on all models
- Stage control program for up to 64 ramp/soak actions

**APPLICATIONS**

- Oven, boiler, or chiller control
- Environmental chambers
- Hot plates/melt pots
- Medical equipment
- Packaging equipment
- Food service equipment

**SPECIFICATIONS**

**Inputs:** Thermocouple, RTD, DC voltages or DC current.  
**Display:** Two 4 digit, 7 segment LED's. PV: Red, SV: Green.  
**Accuracy:** ±0.25% span, ±1 least significant digit.  
**Power Requirements:** 100-240 VAC, 50/60 Hz; Optional 24 VDC.  
**Power Consumption:** 5 VA max.  
**Operating Temperature:** 32 to 122°F (0 to 50°C).  
**Memory Backup:** Nonvolatile memory.  
**Control Output Ratings:** Relay: SPST, 3 A @ 250 VAC resistive for 32B; SPST, 5 A @ 250 VAC resistive for 16B; SPDT, 5 A @ 250 VAC resistive for 8B and 4B;  
 Voltage pulse: 14 VDC (max. 40 mA); Current: 4-20 mA; Linear voltage: 0-10 V.  
**Communication:** RS-485 Modbus® ASCII/RTU communication protocol.  
**Weight:** 32B and 16B: 4 oz (114 g); 8B and 4B: 15 oz (425 g).  
**Front Panel Rating:** IP56.  
**Agency Approvals:** CE, cULus.

Modbus® is a registered trademark of Schneider Automation, Inc.



# TEMPERATURE/PROCESS LOOP CONTROLLERS

Universal Input, Dual Control Output, RS-485 Communication

MODEL CHART - 32B			
Model	Supply Power	Output 1	Output 2
32B-23	100 to 240 VAC	Voltage pulse	Relay
32B-23-LV	24 VDC	Voltage pulse	Relay
32B-33	100 to 240 VAC	Relay	Relay
32B-33-LV	24 VDC	Relay	Relay
32B-53	100 to 240 VAC	Current	Relay
32B-53-LV	24 VDC	Current	Relay

MODEL CHART - 16B			
Model	Supply Power	Output 1	Output 2
16B-23	100 to 240 VAC	Voltage pulse	Relay
16B-23-LV	24 VDC	Voltage pulse	Relay
16B-33	100 to 240 VAC	Relay	Relay
16B-33-LV	24 VDC	Relay	Relay
16B-53	100 to 240 VAC	Current	Relay
16B-53-LV	24 VDC	Current	Relay
16B-63	100 to 240 VAC	Linear voltage	Relay
16B-63-LV	24 VDC	Linear voltage	Relay

MODEL CHART - 8B			
Model	Supply Power	Output 1	Output 2
8B-23	100 to 240 VAC	Voltage pulse	Relay
8B-23-LV	24 VDC	Voltage pulse	Relay
8B-33	100 to 240 VAC	Relay	Relay
8B-33-LV	24 VDC	Relay	Relay
8B-53	100 to 240 VAC	Current	Relay
8B-53-LV	24 VDC	Current	Relay
8B-63	100 to 240 VAC	Linear voltage	Relay
8B-63-LV	24 VDC	Linear voltage	Relay

MODEL CHART - 4B			
Model	Supply Power	Output 1	Output 2
4B-23	100 to 240 VAC	Voltage pulse	Relay
4B-23-LV	24 VDC	Voltage pulse	Relay
4B-33	100 to 240 VAC	Relay	Relay
4B-33-LV	24 VDC	Relay	Relay
4B-53	100 to 240 VAC	Current	Relay
4B-53-LV	24 VDC	Current	Relay
4B-63	100 to 240 VAC	Linear voltage	Relay
4B-63-LV	24 VDC	Linear voltage	Relay
4B-33-986/U	120 VAC	Relay	Relay

**Application Note:**

When using a relay output to operate a contactor or solenoid an R/C snubber should be installed across the coil to prevent damage to the controller relays.



4B-33-986/U Benchtop Controller

INPUT RANGES	
Input Types	Range
K Type TC	-328 to 2372°F (-200 to 1300°C)
J Type TC	-148 to 2192°F (-100 to 1200°C)
T Type TC	-328 to 752°F (-200 to 400°C)
E Type TC	32 to 1112°F (0 to 600°C)
W Type TC	-328 to 2372°F (-200 to 1300°C)
R Type TC	32 to 3092°F (0 to 1700°C)
S Type TC	32 to 3092°F (0 to 1700°C)
B Type TC	212 to 3272°F (100 to 1800°C)
L Type TC	-328 to 1562°F (-200 to 850°C)
U Type TC	-328 to 932°F (-200 to 500°C)
JPt 100 RTD	-4 to 752°F (-20 to 400°C)
Pt 100 RTD	-328 to 1562°F (-200 to 850°C)
0 to 5 V	-999 to 9999
0 to 10 V	-999 to 9999
0 to 20 mA*	-999 to 9999
4 to 20 mA*	-999 to 9999
0 to 50 mV	-999 to 9999

\*Requires 250 Ω precision resistor across input terminals

ACCESSORIES	
Model	Description
MN-1	Mini-Node™ RS-485 to USB converter
SCD-SW	Configuration software
A-277	250 Ω precision resistor
A-600	R/C snubber
A-900	Weatherproof front mount enclosure
A-901	Weatherproof internal mount enclosure with window



A-600



MN-1



A-900



A-901

# TEMPERATURE/PROCESS LOOP CONTROLLERS

Universal Input, Dual Output, On/Off PID or FUZZY Logic Output Control



16G

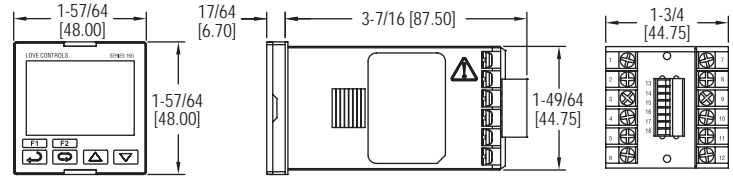

16G



8G

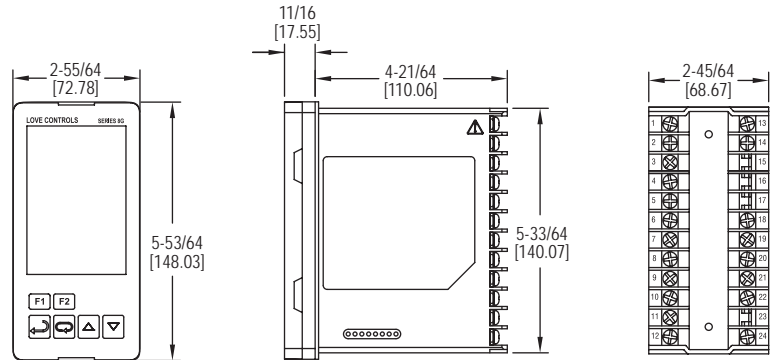

8G



4G

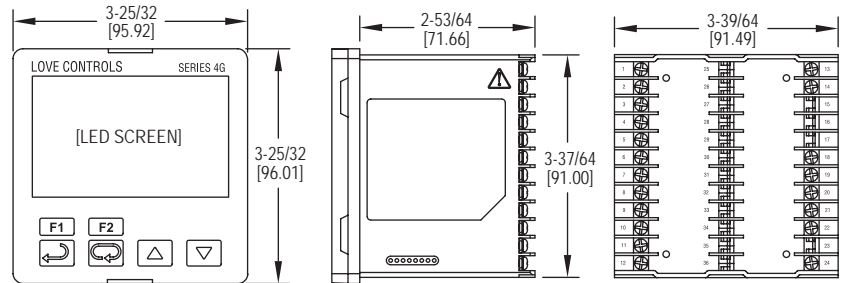

4G

The Series 16G, 8G, & 4G Temperature/Process Loop Controllers allow for monitoring and control of temperature or process conditions. The controller features two independent control outputs for dual loop control using on/off, auto-tune or self-tune PID, fuzzy logic, or manual control methods. RS-485 interface is included with Modbus® communication protocol, for easy bench-top configuration or integration with a PLC or data control system.

## FEATURES/BENEFITS

- On/off, PID, fuzzy logic, or manual output control
- Constant, sloped, program (ramp/soak), or remote set point control
- 2 primary control outputs, 2 secondary/alarm relay outputs, and RS-485 standard on all models
- Remote set point, input retransmission, or event input functions available with optional hardware

## APPLICATIONS

- Oven control
- Packaging equipment
- Parts washers

## SPECIFICATIONS

**Inputs:** Thermocouple, RTD, DC voltages or DC current.  
**Display:** Process value: 4 digit, 0.47" H (12mm), orange LCD; Set point value: 4 digit, 0.47" H (12mm), green LCD.  
**Accuracy:** ± 1.8°F plus ±0.3% of span (±1°C plus ±0.3% of span) at 77°F (25°C) after 20 minutes warm up.  
**Power Requirements:** 100-240 VAC -20/+8%, 50/60 Hz; Optional 24 VDC, ±10%.  
**Power Consumption:** 5 VA max.  
**Operating Temperature:** 32 to 122°F (0 to 50°C).  
**Storage Temperature:** -42 to 150°F (-20 to 65°C).  
**Memory Backup:** Nonvolatile memory.  
**Control Output Ratings:** Relay: SPST, 5 A @ 250 VAC resistive; Voltage pulse: 12 V (max. 40 mA); Current: 4-20 mA; Linear voltage: 0-10 V.  
**Alarm Relay Ratings:** 3 A @ 250 VAC resistive.  
**Communication:** RS-485 Modbus® ASCII/RTU communication protocol.  
**Weight:** 9 oz (255g).  
**Front Panel Rating:** IP66.  
**Agency Approvals:** CE, cULus.

# TEMPERATURE/PROCESS LOOP CONTROLLERS

Universal Input, Dual Output, On/Off PID or FUZZY Logic Output Control

MODEL CHART - 16G				
Model	Output 1	Output 2	Option 1	Option 2
16G-23-11	Voltage pulse	Relay	Event	Event
16G-23-31	Voltage pulse	Relay	Input retrans.	Event
16G-23-32	Voltage pulse	Relay	Input retrans.	Remote SP
16G-33-11	Relay	Relay	Event	Event
16G-33-31	Relay	Relay	Input retrans.	Event
16G-33-32	Relay	Relay	Input retrans.	Remote SP
16G-53-11	Current	Relay	Event	Event
16G-53-31	Current	Relay	Input retrans.	Event
16G-53-32	Current	Relay	Input retrans.	Remote SP
16G-63-11	Linear voltage	Relay	Event	Event
16G-63-31	Linear voltage	Relay	Input retrans.	Event
16G-63-32	Linear voltage	Relay	Input retrans.	Remote SP

MODEL CHART - 8G				
Model	Output 1	Output 2	Option 1	Option 2
8G-23-31	Voltage pulse	Relay	Input retrans.	Event
8G-23-32	Voltage pulse	Relay	Input retrans.	Remote SP
8G-33-31	Relay	Relay	Input retrans.	Event
8G-33-32	Relay	Relay	Input retrans.	Remote SP
8G-53-31	Current	Relay	Input retrans.	Event
8G-53-32	Current	Relay	Input retrans.	Remote SP
8G-63-31	Linear voltage	Relay	Input retrans.	Event
8G-63-32	Linear voltage	Relay	Input retrans.	Remote SP

MODEL CHART - 4G				
Model	Output 1	Output 2	Option 1	Option 2
4G-23-11	Voltage pulse	Relay	Event	Event
4G-23-31	Voltage pulse	Relay	Input retrans.	Event
4G-23-32	Voltage pulse	Relay	Input retrans.	Remote SP
4G-33-11	Relay	Relay	Event	Event
4G-33-31	Relay	Relay	Input retrans.	Event
4G-33-32	Relay	Relay	Input retrans.	Remote SP
4G-53-11	Current	Relay	Event	Event
4G-53-31	Current	Relay	Input retrans.	Event
4G-53-32	Current	Relay	Input retrans.	Remote SP
4G-63-11	Linear voltage	Relay	Event	Event
4G-63-31	Linear voltage	Relay	Input retrans.	Event
4G-63-32	Linear voltage	Relay	Input retrans.	Remote SP

**Application Note:**

When using a relay output to operate a contactor or solenoid an R/C snubber should be installed across the coil to prevent damage to the controller relays.

INPUT RANGES	
Input Types	Range
K Type TC	-328 to 2372°F (-200 to 1300°C)
J Type TC	-148 to 2192°F (-100 to 1200°C)
T Type TC	-328 to 752°F (-200 to 400°C)
E Type TC	32 to 1112°F (0 to 600°C)
N Type TC	-328 to 2372°F (-200 to 1300°C)
R Type TC	32 to 3092°F (0 to 1700°C)
S Type TC	32 to 3092°F (0 to 1700°C)
B Type TC	212 to 3272°F (100 to 1800°C)
L Type TC	-328 to 1562°F (-200 to 850°C)
U Type TC	-328 to 932°F (-200 to 500°C)
TXK Type TC	-328 to 1472 °F (-200 to 800 °C)
JPt 100 RTD	-4 to 752 °F (-20 to 400 °C)
Pt 100 RTD	-328 to 1562 °F (-200 to 850 °C)
Ni 120 RTD	-112 to 572 °F (-80 to 300 °C)
Cu 50 RTD	-58 to 302 °F (-50 to 150 °C)
0 to 5 V	-999 to 9999
0 to 10 V	-999 to 9999
0 to 20 mA*	-999 to 9999
4 to 20 mA*	-999 to 9999
0 to 50 mV	-999 to 9999

\*Requires 250 Ω precision resistor across input terminals

ACCESSORIES	
Model	Description
MN-1	Mini-Node™ RS-485 to USB Converter
SCD-SW	Configuration software
A-277	250 Ω precision resistor
A-600	R/C snubber
A-900	Weatherproof front mount enclosure
A-901	Weatherproof internal mount enclosure with window



A-600



MN-1



A-900



A-901

# DIN RAIL TEMPERATURE/PROCESS CONTROLLERS

Universal Inputs, Up to 8 PID Loops, Modbus® Communications



Master controller



Slave controller

The Series SCD DIN Rail Temperature/Process Controllers offer multiple PID loops in a compact size. Each SCD-1000 master controller can be combined with up to seven SCD-2000 slave controllers without any wires. Each controller has one universal input, one relay output and one user selected output.

**FEATURES/BENEFITS**

- Expandable from 1 to 8 process control loops
- Universal transmitter or temperature sensor inputs
- RS-485 Modbus® communication
- Dual loop or single loop/alarm output control

**APPLICATIONS**

- Oven, boiler, or chiller control
- Hot plates/melt pots
- Packaging equipment
- Environmental chambers
- Medical equipment
- Food service equipment

MODEL CHART			
Model	Controller	Output 1	Output 2
SCD-1023	Master	Voltage pulse	Relay
SCD-1033	Master	Relay	Relay
SCD-1053	Master	Current	Relay
SCD-1063	Master	Linear voltage	Relay
SCD-2023	Slave	Voltage pulse	Relay
SCD-2033	Slave	Relay	Relay
SCD-2053	Slave	Current	Relay
SCD-2063	Slave	Linear voltage	Relay

\*DC current input requires 250 Ω precision resistor

SPECIFICATIONS	
<b>Inputs:</b> Thermocouple, RTD, DC linear voltage, and DC currents.*	<b>Control Output Ratings:</b> Relay: 3 A @ 250 VAC resistive; Voltage pulse: 12 VDC, max. output current: 40 mA; Current: 4-20 mA output; Linear voltage: 0-10 VDC.
<b>Supply Voltage:</b> 24 VDC.	<b>Communication:</b> RS-485 Modbus® A-5-11/RTU communication protocol.
<b>Power Consumption:</b> 3 W.	<b>Weight:</b> 2.7 oz (76.5 g).
<b>Operating Temperature:</b> 32 to 122°F (0 to 50°C).	<b>Agency Approvals:</b> CE, cULus.
<b>Memory Backup:</b> Non-volatile.	

ACCESSORIES	
Model	Description
SCD-PS	100-240 VAC/VDC to 24 VDC power supply
SCD-SW	Configuration software
A-277	250 ohm precision resistor
MN-1	Mini-Node™ USB/RS-485 converter
A-600	R/C snubber

Modbus® is a registered trademark of Schneider Automation, Inc.

**SERIES TSDIN**

# DIN RAIL MOUNT TEMPERATURE SWITCH

HACCP Alarm Logging, Intelligent Defrost

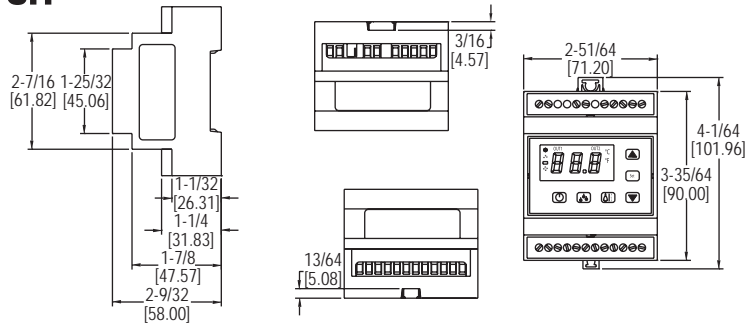

The Series TSDIN DIN Rail Mount Temperature Switch is ideally designed to control compressor, defrost, and fan cycles in refrigeration applications. The digital input can be used to remotely trigger a defrost cycle, monitor cooler door status, or act as an external alarm. Three other probe inputs measure cabinet, defrost, and product temperature. Programming performed on the 6 button keypad or with the Model TS2-K configuration key.

**FEATURES/BENEFITS**

- 3 temperature probe inputs
- Real-time clock used for HACCP logging of temperature limit alarms or loss of power
- Intelligent Defrost parameters manage defrost cycle in order to save energy cost

**APPLICATIONS**

- Refrigerated cabinets
- Walk in coolers
- Applications requiring defrost cycles

MODEL CHART			
Model	Supply Power	# of Outputs	Display Color
TSDIN-013	115 VAC	1, 2, 3	Red
TSDIN-015	115 VAC	1, 2, 3, 4, 5	Red
TSDIN-023	230 VAC	1, 2, 3	Red
TSDIN-025	230 VAC	1, 2, 3, 4, 5	Red
TSDIN-033	12 VAC/VDC	1, 2, 3	Red
TSDIN-043	24 VAC/VDC	1, 2, 3	Red
TSDIN-213	115 VAC	1, 2, 3	Blue
TSDIN-215	115 VAC	1, 2, 3, 4, 5	Blue
TSDIN-223	230 VAC	1, 2, 3	Blue
TSDIN-225	230 VAC	1, 2, 3, 4, 5	Blue
TSDIN-233	12 VAC/VDC	1, 2, 3	Blue
TSDIN-243	24 VAC/VDC	1, 2, 3	Blue

SPECIFICATIONS	
<b>Probe Range:</b> PTC: -58 to 302°F (-50 to 150°C); NTC: -58 to 230°F (-50 to 110°C).	<b>Input:</b> PTC/NTC.
<b>Output:</b> Output 1: SPST relay rated 16A @ 240 VAC resistive, 10 FLA, 60 LRA, 1HP @ 240 VAC inductive; Output 2: SPDT relay rated 8A @ 240 VAC resistive; Output 3: SPST relay rated 8A @ 240 VAC resistive; Output 4: SPDT relay rated 8A @ 240 VAC resistive; Output 5: SPST relay rated 16A @ 240 VAC resistive, 10 FLA, 60 LRA, 1HP @ 240 VAC inductive.	<b>Control Type:</b> On/off.
<b>Power Requirement:</b> 115 VAC, 230 VAC, 12 VAC/VDC, 24 VAC/VDC (±10% depending on model).	<b>Power Consumption:</b> 6 VA.
<b>Accuracy:</b> Better than 1% of full-scale.	<b>Display:</b> 3-digits plus sign.
<b>Resolution:</b> 0.1°.	<b>Memory Backup:</b> Non-volatile memory.
<b>Temperature Limits:</b> Operating: 32 to 131°F (0 to 55°C); Storage: -4 to 176°F (-20 to 80°C).	<b>Weight:</b> 10.8 oz (306 g).
<b>Agency Approvals:</b> CE, cURus.	

ACCESSORIES
See page reference 1 below.

1 Digital Temperature Switch Probes and Accessories: See page 131 (Series TS-Probes)



# TEMPERATURE/PROCESS INDICATOR

Low Cost, 3-Digit Display, 1% Accuracy

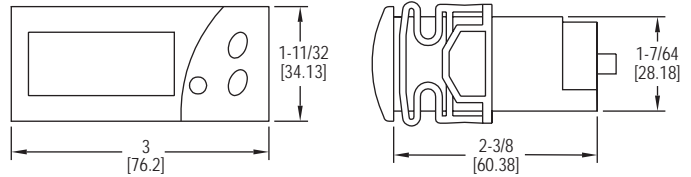

The **Series TID Temperature/Process Indicator** displays temperature or a process value measured by a PTC or NTC thermistor or a 4-20 mA transmitter.

**FEATURES/BENEFITS**

- Thermistor or transmitter input models available
- 3 digit bright LED

**APPLICATIONS**

- Panel process indication
- Refrigerators, walk in coolers

MODEL CHART			
Model	Input	Supply Power	Unit
TID-1110	PTC thermistor	115 VAC	°F
TID-1120	PTC thermistor	115 VAC	°C
TID-1410	PTC thermistor	24 VAC/DC	°F
TID-3100	4-20 mA	115 VAC	None
TID-3200	4-20 mA	230 VAC	None
TID-3400	4-20 mA	24 VAC/DC	None

**SPECIFICATIONS**

**Range:** -58 to 302°F (thermistor); -999 to 999 counts (4-20 mA).  
**Input:** PTC/NTC thermistor or 4-20 mA.  
**Power Requirements:** 115 VAC, 230 VAC, 24 VAC/DC.  
**Accuracy:** > 1%.  
**Display:** 3-digits; red, green or blue display.  
**Resolution:** 1° or 0.1 count.  
**Front Panel Rating:** IP64 (NEMA 3R).  
**Weight:** 2.3 oz (65 g).  
**Agency Approvals:** CE, cURus.

**ACCESSORIES**

See page reference 1 below.

1 Digital Temperature Switch Probes and Accessories: See page 131 (Series TS-Probes)

**SERIES 16L**



# LIMIT CONTROL

FM Approved, Large Dual Display, Universal Input

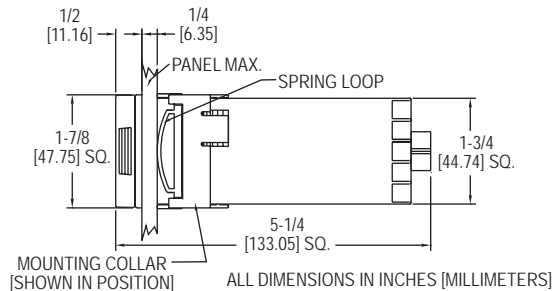

Panel cutout 1.77" + 0.02" [45 mm + 0.6 mm] square

The **Series 16L Limit Control** offers FM approved limit control with universal input, single set point or dual set point control.

**FEATURES/BENEFITS**

- Remote or integral reset button
- Peak and valley temperature indication
- Open sensor protection

**APPLICATIONS**

- Gas fired heater limit control

MODEL CHART		
Model	Output A	Output B
16L2030	N.O. relay	None
16L2034	N.O. relay	N.C. relay

Note: For other configurations, see website

ACCESSORIES	
Model	Description
A-600	R/C snubber

**SPECIFICATIONS**

**Selectable Inputs:** 10 thermocouple, 4 RTD, DC voltage, or DC current selectable.  
**Display:** Two 4 digit, 7 segment 0.3" (7.62 mm) high LEDs.  
**Accuracy:** ±0.25% of span, ±1 least significant digit.  
**Power Requirements:** 100-240 VAC, nominal, +10 -15%, 50 to 400 Hz. single phase; 132-240 VDC, nominal, +10 -20%.  
**Power Consumption:** 5 VA maximum.  
**Temperature Limits:** 14 to 131°F (-10 to 55°C).  
**Memory Backup:** Nonvolatile memory. No batteries required.  
**Output:** Relay: SPST, 3 A @ 240 VAC resistive; 1.5 A @ 240 VAC inductive.  
**Weight:** 8 oz (227 g).  
**Front Panel Rating:** NEMA 4X (IP66).  
**Agency Approvals:** FM, cULus.

**OPTIONS**

To order add suffix:	Description
-934	Process signal output, isolated 0-20 mADC
-936	Process signal output, isolated 0-10 VDC
-992	RS-RS-485 serial communications
-993	RS-RS-232 serial communications

# THERMOCOUPLE LIMIT CONTROL

## FM Approved Temperature Limit Control

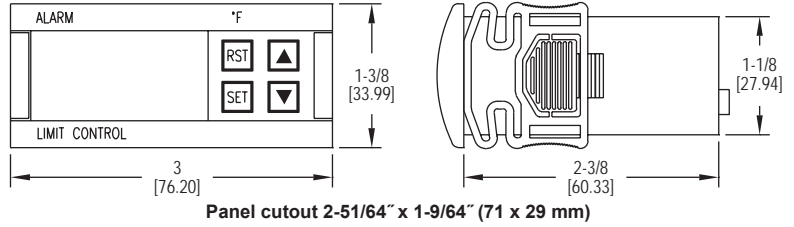

The **Series TSF Thermocouple Limit Control** provides audible alarm status along with a relay output. Unit allows the user to easily select automatic or manual reset via a built in reset button on the front panel or an external contact.

**FEATURES/BENEFITS**

- FM approved temperature limiting control
- Integral and remote reset capabilities

**APPLICATIONS**

- Gas fired oven and burner control

MODEL CHART		
Model	Supply Power	Unit
TSF-4010	115 VAC	°F
TSF-4011	115 VAC	°C
TSF-4021	230 VAC	°C
TSF-4040	24 VAC/VDC	°F

**ACCESSORIES**  
See page reference 1 below.

**SPECIFICATIONS**

**Probe Range:** 32 to 999°F (0 to 700°C) for Type J thermocouple; 32 to 999°F (0 to 999°C) for type K or S thermocouples.  
**Input:** Type J, K or S thermocouple.  
**Output:** SPDT relay rated 16 A @ 240 VAC resistive.  
**Horsepower Rating (HP):** 1 HP.  
**Control Type:** ON/OFF; manual/automatic reset.  
**Power Requirements:** 115 VAC, 230 VAC, 12 VAC/VDC or 24 VAC/VDC (depending on model).  
**Power Consumption:** 4 VA.  
**Accuracy:** ±1% FS.  
**Display:** 3-digit, red, 1/2" (12.7 mm) digits, plus sign.  
**Resolution:** 1°.  
**Memory Backup:** Nonvolatile memory.  
**Temperature Limits:** Ambient: 32 to 150°F (0 to 65°C); Storage: -4 to 176°F (-20 to 80°C).  
**Weight:** 2.3 oz (65 g).  
**Front Panel Rating:** IP64 (NEMA 3R).  
**Agency Approvals:** CE, FM, cURus.

1 Digital Temperature Switch Probes and Accessories: See page 131 (Series TS-Probes)

SERIES TSF-DF

# THERMOCOUPLE LIMIT CONTROL

## UL Approved Temperature Limit Control

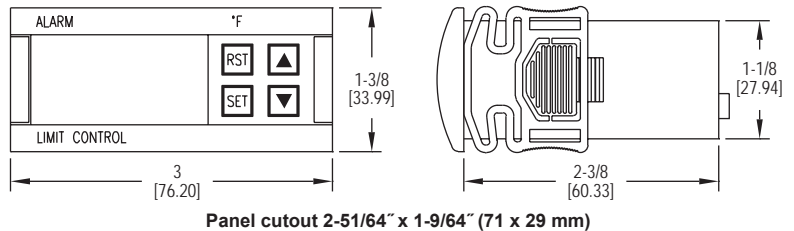

The **Series TSF-DF Thermocouple Limit Control** is a UL approved temperature limit control that provides visual alarm status along with a relay output. The Series TSF-DF controls have a built in reset button on the front panel or can accept an external reset signal.

Program settings on model TSF-DF controls cannot be changed through the buttons on the device. It is necessary to purchase a model TSF-MDF and a model TS2-K in addition to the model TSF-DF. Desired program parameters are entered on a TSF-MDF programming control. Using the TS2-K configuration key, the parameters can be easily copied from the TSF-MDF and transferred to the TSF-DF Limit Alarms.

**FEATURES/BENEFITS**

- UL approved limit control

**APPLICATIONS**

- Gas fired oven and burner control

MODEL CHART			
Model	Control	Supply Power	Unit
TSF-4010-DF	Limit alarm	115 VAC	°F
TSF-4011-DF	Limit alarm	115 VAC	°C
TSF-4021-DF	Limit alarm	230 VAC	°C
TSF-4040-DF	Limit alarm	24 VAC/VDC	°F
TSF-4010-MDF	Programming control	115 VAC	°F
TSF-4011-MDF	Programming control	115 VAC	°C
TSF-4021-MDF	Programming control	230 VAC	°C
TSF-4040-MDF	Programming control	24 VAC/VDC	°F

**SPECIFICATIONS**

**Probe Range:** 32 to 999°F (0 to 700°C) for thermocouple J type; 32 to 999°F (0 to 999°C) for thermocouple K or S type.  
**Input:** Type J, K, or S thermocouple.  
**Output:** NO SPST relay rated 16 A @ 240 VAC resistive.  
**Horsepower Rating (HP):** 1 HP.  
**Control Type:** ON/OFF; manual/automatic reset.  
**Power Requirements:** See model chart.  
**Power Consumption:** 4 VA @ 230 VAC.  
**Accuracy:** ±1% FS.  
**Display:** 3-digit, red, 1/2" (12.7 mm) digits, plus sign.  
**Resolution:** 1°.  
**Memory Backup:** Nonvolatile memory.  
**Ambient Operating Temperature:** 32 to 140°F (0 to 60°C).  
**Storage Temperature:** -4 to 176°F (-20 to 80°C).  
**Weight:** 2.3 oz (65 g).  
**Front Panel Rating:** IP64.  
**Agency Approvals:** CE, cURus (DF models only).

**ACCESSORIES**  
See page reference 1 below.

1 Digital Temperature Switch Probes and Accessories: See page 131 (Series TS-Probes)

# DIGITAL TEMPERATURE SWITCH

## 3-1/2 Digit Display, Programming Configuration Key



40X-K configuration key

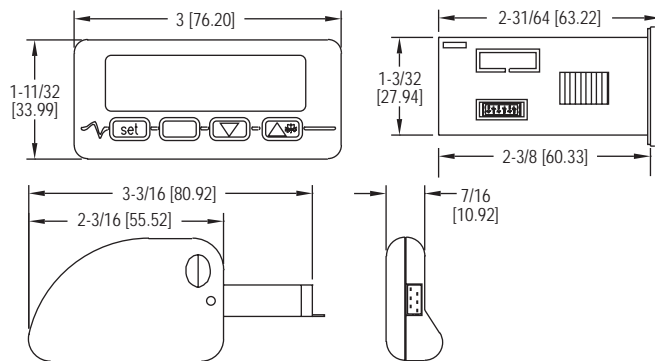

The **Series 40T/40M Digital Temperature Switch** accepts a variety of inputs to allow temperature measurements and set points up to 1999°F (1300°C).

### FEATURES/BENEFITS

- Field selectable °F or °C
- Universal temperature sensor or transmitter input on 40M models
- Configuration key to quickly load parameters from one unit to another
- Heating or cooling models

### APPLICATIONS

- Food service equipment
- Industrial process control

### SPECIFICATIONS

**Probe Range:** K T/C: -140 to 1999°F (-100 to 1300°C); J T/C: -140 to 1450°F (-100 to 800°C); RTD: -320 to 1200°F (-200 to 650°C); PTC: -58 to 300°F (-50 to 150°C); NTC: -40 to 230°F (-40 to 110°C); N. RTD: -110 to 570°F (-80 to 300°C).  
**Output:** 16 A @ 250 VAC SPDT relay (max current allowed is 10 A).  
**Control Type:** On/off.

**Power Requirements:** 12-24 VAC/VDC, 115 VAC or 230 VAC depending on model.  
**Accuracy:** ±1% FS.  
**Display:** 3-1/2 digit red display.  
**Resolution:** 0.1°C.  
**Memory Backup:** Non-volatile memory.  
**Ambient Temperature:** 32 to 131°F (0 to 55°C).  
**Weight:** 2.3 oz (65 g).  
**Front Panel Rating:** IP65.  
**Agency Approvals:** CE, cULus.

### MODEL CHART

Thermocouple/ RTD Input Model	Supply Power	Universal Input Model	Supply Power
40T-10	115 VAC	40M-10	115 VAC
40T-20	230 VAC	40M-20	230 VAC
40T-40	12-24 VAC/VDC	40M-40	12-24 VAC/VDC

### ACCESSORIES

Model	Description
40X-K	Configuration key

For sensor accessories, see page reference 1 below.

1 Digital Temperature Switch Probes and Accessories: See page 131 (Series TS-Probes)

## SERIES TCS

# THERMOCOUPLE TEMPERATURE SWITCH

## Heating and Cooling Control, 16 Amp Rating, Two Alarms

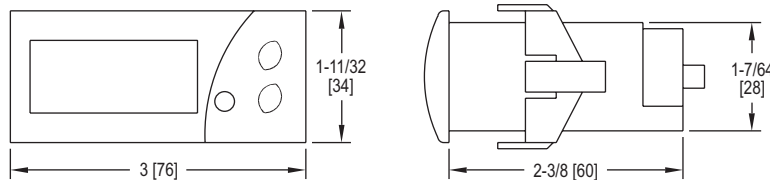

Panel cutout 2-51/64" x 1-9/64" (71 mm x 29 mm)

The **Series TCS Thermocouple Temperature Switch** monitors and controls temperature while offering a wide temperature range, two selectable alarm sets, and an internal buzzer indicating alarm condition or error.

### FEATURES/BENEFITS

- Heating or cooling modes
- Internal alarm buzzer
- Configuration key to quickly load parameters from one unit to another

### APPLICATIONS

- Food service equipment
- Industrial process control

### SPECIFICATIONS

**Probe Range:** 32 to 999°F (0 to 700°C) for Type J thermocouple; 32 to 999°F (0 to 999°C) for Type K thermocouple.  
**Input:** Type J or K thermocouple.  
**Output:** SPDT relay rated 16 A @ 240 VAC resistive.  
**Horsepower Rating (HP):** 1 HP.  
**Control Type:** ON/OFF.  
**Power Requirements:** 115 VAC, 230 VAC, 12 VAC/VDC or 24 VAC/VDC (depending on model).

**Accuracy:** ±1% FS.  
**Display:** 3-digit, red, 1/2" (12.7 mm) digits, plus sign.  
**Resolution:** 1°.  
**Memory Backup:** Nonvolatile memory.  
**Temperature Limits:** Ambient: 32 to 158°F (0 to 70°C); Storage: -4 to 176°F (-20 to 80°C).  
**Weight:** 2.3 oz (65 g).  
**Front Panel Rating:** IP64.  
**Agency Approvals:** CE, cURus.

### MODEL CHART

Model	Supply Power	Unit	Model	Supply Power	Unit
TCS-4010	115 VAC	°F	TCS-4030	12 VAC/VDC	°F
TCS-4011	115 VAC	°C	TCS-4031	12 VAC/VDC	°C
TCS-4020	230 VAC	°F	TCS-4040	24 VAC/VDC	°F
TCS-4021	230 VAC	°C			

### ACCESSORIES

See page reference 1 below.

1 Digital Temperature Switch Probes and Accessories: See page 131 (Series TS-Probes)

# DIGITAL TEMPERATURE SWITCH

## Heating and Cooling Control, 16 Amp Rating

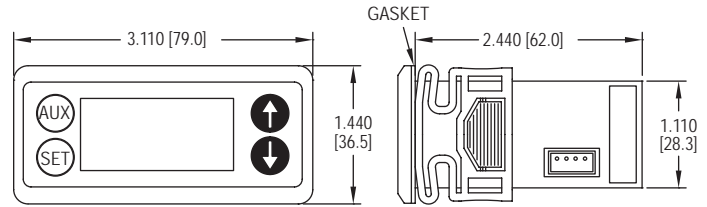

Panel cutout 2-51/64" x 1-9/64" (71 x 29 mm)

The **Series TST Digital Temperature Switch** is designed with many heating and cooling applications in mind. This low cost switch is simple to set up with one probe input and SPDT switch output. Programming performed using either the front keypad or through a TS2-K programming key.

**FEATURES/BENEFITS**

- Buzzer indicates probe/memory error or high/low temperature alarm conditions
- Capacitive buttons offer clean panel face design
- Modbus® communication protocol through TTL serial connection

**APPLICATIONS**

- Refrigeration
- Holding ovens
- Boilers
- Brewing systems

MODEL CHART	
Model	Supply Power
TST-011	115 VAC
TST-021	230 VAC
TST-031	12 VAC/VDC
TST-041	24 VAC/VDC

ACCESSORIES
See page reference 1 below.

SPECIFICATIONS
<b>Probe Range:</b> PTC: -58 to 302°F (-50 to 150°C); NTC: -58 to 230°F (-50 to 110°C).
<b>Input:</b> PTC (1000 Ω @ 25°C) or NTC (10 KΩ @ 25°C) thermistor.
<b>Output:</b> SPDT relay rated 16 A @ 240 VAC resistive, 10 FLA, 60 LRA.
<b>Horsepower Rating (HP):</b> 1 HP.
<b>Control Type:</b> On/Off.
<b>Power Requirements:</b> 115 VAC, 230 VAC, 24 VAC/VDC, or 12 VAC/VDC.
<b>Power Consumption:</b> 4 VA @ 115/230 VAC; 1.5 VA @ 12/24 VAC/VDC.
<b>Accuracy:</b> ±1% FS.
<b>Display:</b> 3-digit, plus sign.
<b>Resolution:</b> 0.1°.
<b>Memory Backup:</b> Nonvolatile memory.
<b>Ambient Temperature:</b> 32 to 131°F (0 to 55°C).
<b>Storage Temperature:</b> -4 to 176°F (-20 to 80°C).
<b>Weight:</b> 115 and 230 V models: 7.2 oz (204 g); 12 and 24 V models: 4.8 oz (136 g).
<b>Front Panel Rating:</b> IP65.
<b>Agency Approvals:</b> CE, cURus.

Modbus® is a registered trademark of Schneider Automation, Inc.

1 Digital Temperature Switch Probes and Accessories: See page 131 (Series TS-Probes)

SERIES TSXT

# DIGITAL TEMPERATURE SWITCH

## Refrigeration Control, Up To 3 Probe Inputs and 3 Relay Outputs

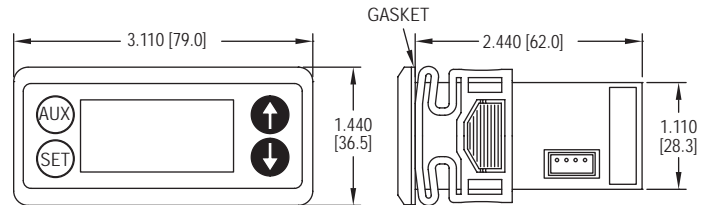

Panel cutout 2-51/64" x 1-9/64" (71 x 29 mm)

The **Series TSXT Digital Temperature Switch** is designed for refrigeration control. It accepts PTC or NTC temperature probe types and can control the compressor, defrost, fan, alarm, and light in a refrigeration system. Master/slave configurations allow synchronization of defrost cycles between different units. Programming is performed through the front keypad, or by using the TS2-K programming key.

**FEATURES/BENEFITS**

- Models available with 1, 2, or 3 relay outputs
- 3 temperature inputs and one digital input for complete refrigeration control
- Configuration key available for programing multiple units
- Capacitive buttons offer clean panel face design
- Modbus® communication protocol through TTL serial connection

**APPLICATIONS**

- Refrigerated cabinets
- Walk in coolers
- Applications requiring defrost cycles

MODEL CHART					
Model	Supply Power	Outputs	Model	Supply Power	Outputs
TSXT-211	115 VAC	1	TSXT-232	12 VAC/VDC	2
TSXT-221	230 VAC	1	TSXT-242	24 VAC/VDC	2
TSXT-231	12 VAC/VDC	1	TSXT-213	115 VAC	3
TSXT-241	24 VAC/VDC	1	TSXT-223	230 VAC	3
TSXT-212	115 VAC	2	TSXT-233	12 VAC/VDC	3
TSXT-222	230 VAC	2	TSXT-243	24 VAC/VDC	3

SPECIFICATIONS	
<b>Probe Range:</b> PTC: -58 to 302°F (-50 to 150°C); NTC: -58 to 230°F (-50 to 110°C).	<b>Power Consumption:</b> 3.6 VA @ 115/230 VAC; 1.5 VA @ 12/24 VAC/VDC.
<b>Input:</b> PTC (1000 Ω @ 25°C) or NTC (10 KΩ @ 25°C) thermistor.	<b>Accuracy:</b> ±1% FS.
<b>Output:</b> Relay 1: SPST relay rated 16 A @ 240 VAC resistive, 10 FLA, 60 LRA; Relay 2: SPST relay rated 5 A @ 240 VAC resistive; Relay 3: SPST relay rated 8 A @ 240 VAC resistive.	<b>Display:</b> 3-digit, plus sign.
<b>Horsepower Rating (HP):</b> 1 HP (Relay 1).	<b>Resolution:</b> 0.1°.
<b>Control Type:</b> On/off with defrost options.	<b>Memory Backup:</b> Nonvolatile memory.
<b>Power Requirements:</b> 115 VAC, 230 VAC, 24 VAC/VDC, or 12 VAC/VDC.	<b>Ambient Operating Temperature:</b> 32 to 131°F (0 to 55°C).
	<b>Storage Temperature:</b> -4 to 176°F (-20 to 80°C).
	<b>Weight:</b> 115 and 230 V models: 7.2 oz (204 g); 12 and 24 V models: 4.8 oz (136 g).
	<b>Front Panel Rating:</b> IP65.
	<b>Agency Approvals:</b> CE, cURus.

ACCESSORIES
See page reference 1 below.

Modbus® is a registered trademark of Schneider Automation, Inc.

1 Digital Temperature Switch Probes and Accessories: See page 131 (Series TS-Probes)



# DIGITAL TEMPERATURE SWITCH

Easy Multi-Unit Programming, 16A SPDT Relay Output

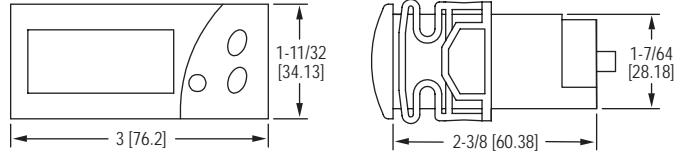

Panel cutout 2-51/64" x 1-9/64" (71 mm x 29 mm)

The **Series TS2 Digital Temperature Switch** offers an easy to use OEM friendly solution to monitor and control temperature in heating or cooling applications.

### FEATURES/BENEFITS

- Simple to use temperature control device
- Configuration key

### APPLICATIONS

- Refrigerators
- Chillers
- Food service equipment
- Medical sterilizers or equipment

MODEL CHART		
Model	Supply Power	Unit
TS2-010	115 VAC	°F
TS2-011	115 VAC	°C
TS2-020	230 VAC	°F
TS2-030	12 VAC/VDC	°F
TS2-040	24 VAC/VDC	°F
TS2-041	24 VAC/VDC	°C

### SPECIFICATIONS

**Probe Range:** -58 to 302°F (-50 to 150°C).  
**Input:** PTC (1000Ω @ 25°C).  
**Output:** 16 A SPDT relay @ 250 VAC resistive, 5 A inductive.  
**Horsepower Rating (HP):** 1 HP.  
**Control Type:** On/off.  
**Power Requirements:** 115 VAC, 230 VAC, 12 VAC/VDC or 24 VAC/VDC.  
**Accuracy:** ±1% FS.  
**Display:** 3-digit, red, 1/2" digits.  
**Resolution:** 1°.  
**Memory Backup:** Nonvolatile memory.  
**Temperature Limits:** Ambient: 32 to 158°F (0 to 70°C).  
**Storage Temperature:** -4 to 176°F (-20 to 80°C).  
**Weight:** 2.3 oz (65 g).  
**Front Panel Rating:** IP64.  
**Agency Approvals:** CE, cURus.

### ACCESSORIES

See page reference 1 below.

1 Digital Temperature Switch Probes and Accessories: See page 131 (Series TS-Probes)

## SERIES TSS2

# DUAL STAGE TEMPERATURE SWITCH

Two Independent Relay Outputs, Heating or Cooling Control

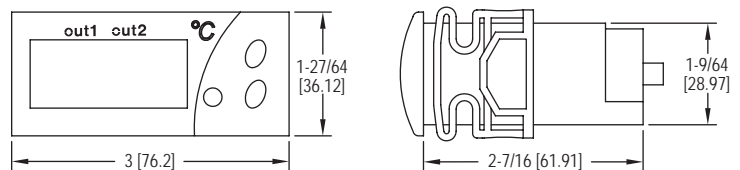

Panel cutout 2-51/64" x 1-9/64" (71 mm x 29 mm)

The **Series TSS2 Dual Stage Temperature Switch** features two independent sensor inputs and control outputs in one device.

### FEATURES/BENEFITS

- Simple to use dual temperature control device
- Configuration key

### APPLICATIONS

- Refrigerators
- Chillers
- Food service equipment
- Medical sterilizers or equipment

MODEL CHART		
Model	Supply Power	Unit
TSS2-2100	115 VAC	°F
TSS2-2110	115 VAC	°C
TSS2-2210	230 VAC	°C
TSS2-2300	12 VAC/DC	°F
TSS2-2400	24 VAC/DC	°F

### SPECIFICATIONS

**Probe Range:** PTC: -58 to 302°F (-50 to 150°C); NTC: -58 to 230°F (-50 to 110°C).  
**Input:** PTC (1000Ω @ 25°C); NTC (10KΩ @ 25°C).  
**Outputs:** OUT1=SPDT relay rated 16 A @ 240 VAC resistive; OUT2=SPDT relay rated 8 A @ 240 VAC resistive.  
**Horsepower Rating (HP):** 1 HP (OUT1).  
**Power Requirements:** 115 VAC, 230 VAC, 12 VAC/VDC or 24 VAC/VDC (depending on model).  
**Accuracy:** ±1% FS.  
**Display:** 3-digit and sign, red LED.  
**Resolution:** 0.1° (< 100°); 1° (≥ 100°).  
**Memory Backup:** Nonvolatile memory.  
**Temperature Limit:** Ambient: 32 to 158°F (0 to 70°C).  
**Storage Temperature:** -4 to 176°F (-20 to 80°C).  
**Dimensions:** 3 x 1-27/64 x 2-7/16 in.  
**Front Panel Rating:** IP64.  
**Weight:** 2.3 oz (65 g).  
**Agency Approvals:** CE, cURus.

### ACCESSORIES

See page reference 1 below.

1 Digital Temperature Switch Probes and Accessories: See page 131 (Series TS-Probes)

# WEATHER PROOF DIGITAL TEMPERATURE SWITCH

NEMA 4X Housing, Single or Dual Stage, 20 A Contact Rating

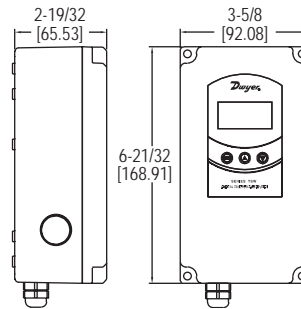

The Series TSW Weather Proof Digital Temperature Switch combines the trusted, reliable TS family of temperature controls and an installation friendly weatherproof enclosure. The bright, easy-to-read LED display shows the current output status and the temperature measurement.

**FEATURES/BENEFITS**

- Weatherproof housing
- Single or dual stage models
- Configuration key
- Physical and passcode parameter setting protection

**APPLICATIONS**

- Chillers
- Walk in cooler
- Woodboilers
- Brewing systems

**MODEL CHART**

Model	Description	Temperature Probe Included	Supply Power
TSW-150	Single stage	TS-8T	90 to 255 VAC
TSW-160	Single stage	TS-8T	12 to 24 VAC/VDC
TSW-250	Dual stage	TS-8T	90 to 255 VAC
TSW-260	Dual stage	TS-8T	12 to 24 VAC/VDC
TSW-150-NP	Single stage	None	90 to 255 VAC
TSW-160-NP	Single stage	None	12 to 24 VAC/VDC
TSW-250-NP	Dual stage	None	90 to 255 VAC 12
TSW-260-NP	Dual stage	None	12 to 24 VAC/VDC

**SPECIFICATIONS**

**Probe Range:** PTC: -58 to 302°F (-50 to 150°C); NTC: -58 to 230°F (-50 to 110°C).  
**Input:** PTC (1000Ω @ 25°C); NTC (10K Ω @ 25°C).  
**Output:** R1 SPDT relay resistive load: 20 A @ 240 VAC; R2 SPDT relay resistive load: 8 A @ 240 VAC; Inductive load: 3 A @ 240 VAC.  
**Horsepower Rating:** R1 2HP @ 240 VAC.  
**Control Type:** On/off.  
**Power Requirements:** 90 to 255 VAC or 12 to 24 VAC/VDC (±10%) depending on model.  
**Power Consumption:** 3.6 VA.  
**Accuracy:** ±1% FS.  
**Display:** 3 digits plus sign.  
**Resolution:** Single stage: 1°; Dual stage: 0.1° < 100; 1° ≥ 100°.  
**Memory Backup:** Non-volatile memory.  
**Ambient Temperature:** 32 to 104°F (0 to 40°C).  
**Weight:** 1.2 lb (544 g).  
**Enclosure Rating:** NEMA 4X (IP66).  
**Agency Approvals:** CE, cURus.

**ACCESSORIES**

Model	Description
CC1-N	Temperature sensor clip, neutral
CC1-GY	Temperature sensor clip, grey

Temperature Switches, Digital

**SERIES TSWB**

# DIGITAL TEMPERATURE/WATER LEVEL SWITCH

Two Temperature Set Points, Low Water Level Alarm

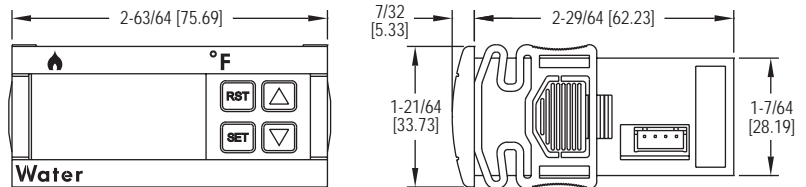

The Series TSWB Digital Temperature/Water Level Switch offers complete boiler control for outdoor wood boilers and other similar heating equipment.

**FEATURES/BENEFITS**

- 3 outputs for high temp, low temp or input alarm
- Conductivity probe input for water level monitoring
- Configuration key

**APPLICATIONS**

- Wood or pellet boilers

**MODEL CHART**

Model	Supply Power	Unit
TSWB-010	115 VAC	°F
TSWB-011	115 VAC	°C

**ACCESSORIES**

See page reference 1 below.

**SPECIFICATIONS**

**Probe Range:** PTC: -58 to 302°F (-50 to 150°C); NTC: -58 to 230°F (-50 to 110°C).  
**Probe Temperature Input:** PTC (1000Ω @ 25°C); NTC (10KΩ @ 25°C).  
**Probe Level Input:** Conductivity probe: Max voltage 12 VAC. Sensitivity established from factory at 100KΩ.  
**Output:** R1 SPST NO relay resistive load 5 A @ 250 VAC; R2 SPST NC relay resistive load 5 A @ 250 VAC; R3 SPDT relay resistive load 16 A @ 240 VAC.  
**Horsepower Rating:** 1HP -- 10FLA, 60LRA 250 VAC.  
**Control Type:** On/off.  
**Power Requirements:** 115 VAC ± 10%, 230 VAC ± 10%, 24 VAC/DC ± 10%, 12 VAC/DC ± 10%.  
**Power Consumption:** 4VA (230V/115V), 1.5VA (24V/12V).  
**Accuracy:** > 1% of full-scale.  
**Display:** 3-digit, red 1/2" digits.  
**Resolution:** 1° (3 digits).  
**Memory Backup:** Nonvolatile memory.  
**Ambient Operating Temperature:** 32 to 158°F (-30 to 70°C).  
**Storage Temperature:** -4 to 176°F (-30 to 80°C).  
**Weight:** 3.5 oz.  
**Front Protection:** IP64.  
**Agency Approvals:** CE, cULus.

1 Digital Temperature Switch Probes and Accessories: See page 131 (Series TS-Probes)

# DIGITAL TEMPERATURE SWITCH PROBES & ACCESSORIES

Probes to be used with TS2, TSS2, TSWB, TSW, TS3, TSX3, and 40M

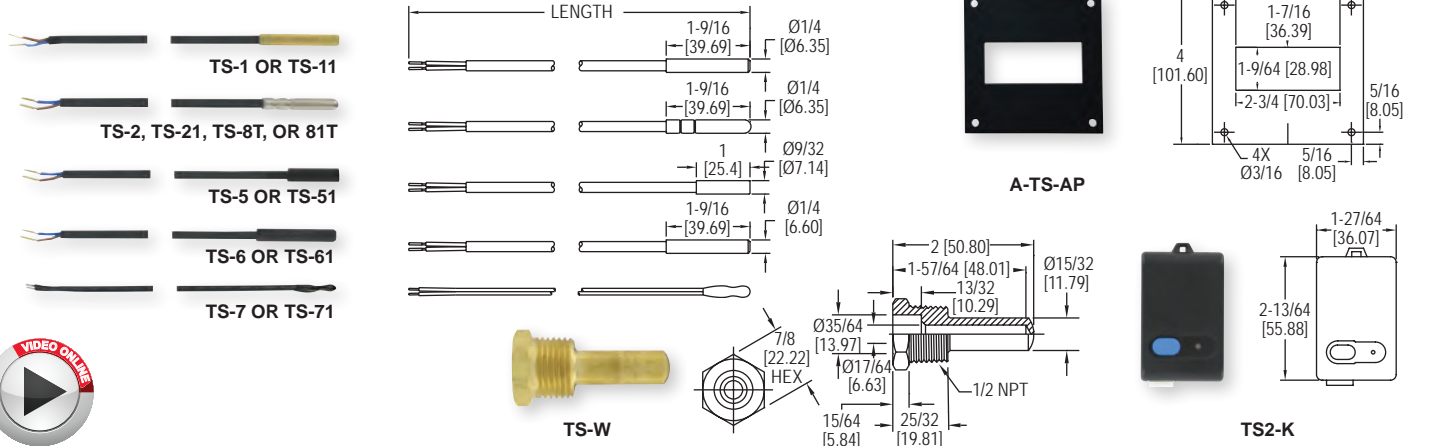

**FEATURES/BENEFITS**

- 5 or 10 foot cable lengths
- PTC or NTC temperature curves

**APPLICATIONS**

- Refrigerated cabinets
- Walk in coolers
- Food service equipment
- Medical sterilizers or equipment
- Wood or pellet boilers
- Brewing systems

**SPECIFICATIONS**

**Sensor:** See model chart.  
**Operating Temperature:** PTC or NTC: -58 to 221°F (-50 to 105°C); J-type: 32 to 1400°F (0 to 760°C); K-type: 32 to 2300°F (0 to 1200°C).  
**Cable:** PTC and NTC models: PVC; J-type and K-type models: FEP.

**MODEL CHART - SENSORS**

Model	Sensor	Cap Material	Length ft (m)	Model	Sensor	Cap Material	Length ft (m)
TS-1	PTC	Brass	5 (1.5)	TS-7	NTC	None	5 (1.5)
TS-11	PTC	Brass	10 (3)	TS-71	NTC	None	10 (3)
TS-2	PTC	Stainless steel	5 (1.5)	TS-8T	NTC	Stainless steel	5 (1.5)
TS-21	PTC	Stainless steel	10 (3)	TS-81T	NTC	Stainless steel	10 (3)
TS-5	PTC	PVC	5 (1.5)	TS-88T	NTC	Stainless steel	15 (4.5)
TS-51	PTC	PVC	10 (3)	TCS-J	J-type	Stainless steel	4 (1.21)
TS-6	PTC	Polyamide resin coated brass	5 (1.5)	TCS-K	K-type	Stainless steel	4 (1.21)
TS-61	PTC	Polyamide resin coated brass	10 (3)				

**ACCESSORIES**

Model	Description
A-TS-AP	1/4 DIN adapter plate
TS2-K	Configuration key
TS-W	Brass thermowell (for use with TS-1, TS-11, TS-2, TS-21)

**SERIES DFS2**

## LOW LIMIT FREEZE PROTECTION SWITCH

Manual and Automatic Reset



Manual reset option shown

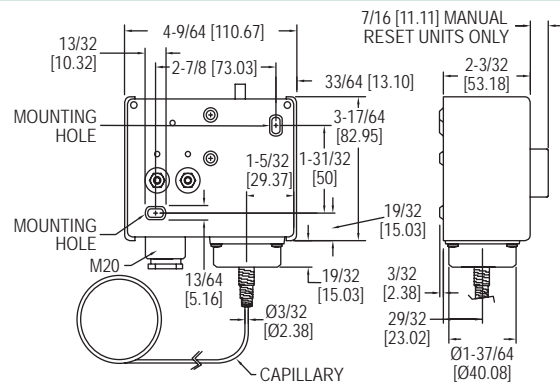

The **Series DFS2 Low Limit Freeze Protection Switch** protects cooling coils in air handler systems by preventing frost build up. The thermostat and its capillary sensing element provide an antifreeze function by sensing the lowest temperature along any one foot section of capillary. The DPDT manual or automatic reset relays signal the building management system as well as cut off the fan. The Series DFS2 will detect temperature drops below the fixed safety value (set point) which can be set as low as 34°F (1°C) utilizing the visual set point indicator and set point screw.

**FEATURES/BENEFITS**

- Vapor-filled copper capillary sensing element
- Joint spring protector at capillary-bellow connection
- Set point safety-lock protection and simple adjustment
- Easy installation and wiring
- Automatic and manual reset

**APPLICATIONS**

- HVAC equipment
- Heat exchangers and cooling coils

**MODEL CHART**

Model	Reset Action	Capillary Length
DFS2-DA10	Automatic	10' (302 cm)
DFS2-DA20	Automatic	20' (609 cm)
DFS2-DM10	Manual	10' (302 cm)
DFS2-DM20	Manual	20' (609 cm)

**SPECIFICATIONS**

**Sensing Element:** Vapor-filled capillary.  
**Operating Temperature:** 14°F to 54°F (-10°C to 12°C).  
**Storage Temperature:** 14°F to 158°F (-10°C to 70°C).  
**Capillary Overload Temperature:** 392°F (200°C), maximum 60 minutes.  
**Humidity Limit:** 0 to 95% RH, non-condensing.  
**Enclosure:** Galvanized steel base, ABS cover.  
**Enclosure Rating:** NEMA 1 (IP40).  
**Capillary Material:** Copper.  
**Cable Entry:** (1) M20 compression fitting.

**Reset Action:** Available in automatic or manual reset options.  
**Low-level Setpoint:** Factory Set: 39°F (4°C), and safety lock secured; Adjustment via screwdriver slot.  
**Wire Connection:** Terminal with wire-retaining screws.  
**Wire Size:** Max. 14 AWG.  
**Electrical Rating:** 24-250 VAC, 15 (8) A.  
**Electrical Connections:** Two each NO/NC/Common.  
**Deadband:** 1.8°F (fixed).  
**Weight:** 1.6 lb (0.7 kg).  
**Agency Approvals:** CE.

**ACCESSORIES**

Model	Description
A-DFS2-C	Capillary mounting clips





MODEL 862E | MERCROID® BY DWYER



# EXPLOSION-PROOF, HEAVY-DUTY THERMOSTAT

Line or Low Voltage, Heating or Cooling

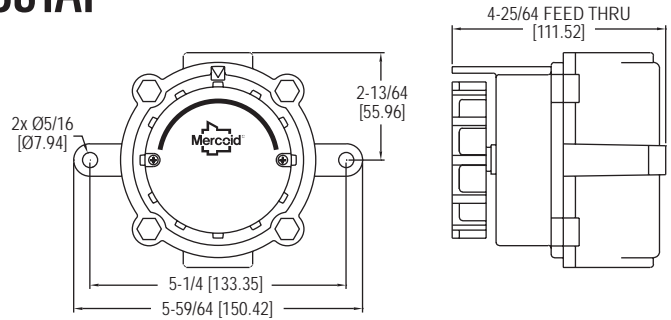

The **Model 862E Explosion-Proof, Heavy-Duty Thermostat** is designed for hazardous-location temperature control of heating, cooling, or ventilation systems and features an adjustable set point knob for easy and convenient set point adjustment.

**FEATURES/BENEFITS**

- Explosion-proof construction
- Lightweight and durable

**APPLICATIONS**

- Oil rigs or refineries
- Petrochemical plants
- Grain processing and storage facilities
- HVAC control

**MODEL CHART**

Model	Description
862E	Explosion-proof, heavy-duty thermostat

**SPECIFICATIONS**

**Service:** Compatible gases.  
**Temperature Limit:** -49 to 176°F (-45 to 80°C).  
**Enclosure Rating:** Explosion-proof NEMA 7 & 9, Class I, Divisions 1 & 2, Groups C & D; Class II, Division 1, Groups E, F & G; Class II, Division 2, Groups F & G; Class III; Class I, Zones 1 & 2, Groups IIA & IIB.  
**Switch Type:** SPDT snap action switch.  
**Electrical Rating:** 22 A @ 480 VAC (res.), 1/2 HP @ 125 VAC, 1 HP @ 250 VAC.  
**Electrical Connection:** Screw terminal.  
**Conduit Connection:** 3/4" female NPT.  
**Set Point Adjustment:** External knob.  
**Adjustable Range:** 36 to 82°F (2 to 28°C).  
**Deadband:** 2.5°F (1.5°C).  
**Weight:** 2.1 lb (0.95 kg).  
**Agency Approvals:** CSA, UL.

USA: California Proposition 65

⚠️WARNING: Cancer and Reproductive Harm - www.P65Warnings.ca.gov

SERIES DA-7035N | MERCROID® BY DWYER

# TEMPERATURE SWITCH

Bulb and Capillary, Inert Gas Fill

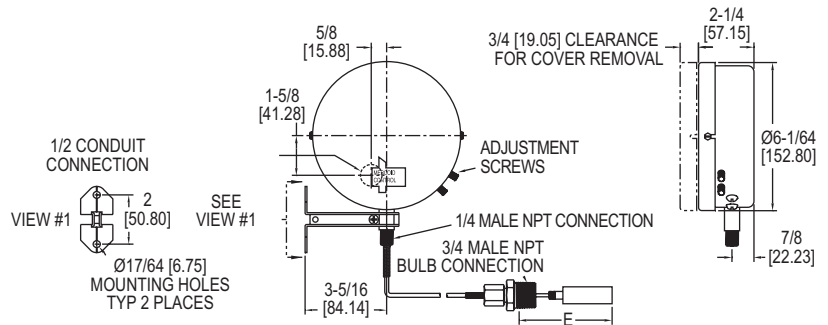

The **Series DA-7035N Temperature Switch** includes the same time-proven switching mechanism used in our Series DA pressure switches. Bourdon tube ensures high sensitivity and long life.

**FEATURES/BENEFITS**

- Adjustable deadband
- No cross ambient temperature effects
- Visible dial calibrated in both °F and °C
- Visible on/off indication

**APPLICATIONS**

- Mechanical process temperature monitoring

**SPECIFICATIONS**

**Service:** Compatible liquids or gases.  
**Wetted Materials:** Bulb and connection: 304 SS.  
**Temperature Limit:** Process: See model chart; Ambient: 180°F (82°C).  
**Pressure Limit:** 300 psi (20.6 bar).  
**Enclosure Rating:** General purpose. Optional weatherproof and explosion-proof.  
**Repeatability:** ±1% FS.  
**Switch Type:** SPDT snap switch. Optional DPDT snap and a variety of mercury switches.  
**Electrical Rating:** 10 A @ 120/240/480 VAC.  
**Electrical Connections:** Screw terminal.  
**Conduit Connection:** 7/8" (22.23 mm) hole for 1/2" (12.7 mm) conduit hub.

**Process Connection:** 3/4" male NPT. Other sizes available.  
**Set Point Adjustment:** External knobs for set point and reset point.  
**Weight:** 5 lb (2.3 kg).  
**Deadband:** Adjustable from minimum in model chart to full range. Optional low fixed deadband.  
**Capillary:** 6' (1.8 m) standard. Ranges 1N to 7N, and 10N: copper. Ranges 8N, 9N, 11N: 304 SS.  
**Set Point Scale:** Indication in °F and °C.  
**Options:** See web page for additional option models such as: switch type enclosures, fixed deadband, longer or shorter capillary, armored capillary, wells, two stage, 1/2" or 1" connection sizes, manual reset.

**MODEL CHART**

Model	Range °F (°C)	Max. Temp. °F (°C)	Min. Deadband °F (°C)	Min. Insertion Depth "E" in. (mm)
DA-7035-153-1N	-60 to +30 (-50 to 0)	150 (65)	23 (13)	2-7/8 (73)
DA-7035-153-3N	0 to 100 (-18 to 40)	240 (115)	25 (14)	2-7/8 (73)
DA-7035-153-4N	50 to 150 (10 to 65)	250 (120)	25 (14)	2-7/8 (73)
DA-7035-153-5N	100 to 200 (40 to 95)	300 (150)	25 (14)	2-7/8 (73)
DA-7035-153-7N	140 to 300 (60 to 150)	500 (260)	41 (23)	2-7/8 (73)
DA-7035-153-8N	250 to 415 (120 to 215)	550 (290)	42 (23)	2-7/8 (73)
DA-7035-153-9N	350 to 550 (175 to 290)	600 (315)	50 (28)	4-7/8 (124)
DA-7035-153-10N	100 to 300 (40 to 150)	500 (260)	50 (28)	2-7/8 (73)
DA-7035-153-11N	100 to 500 (40 to 260)	600 (315)	100 (56)	2-7/8 (73)

**Note:** Insertion depth can be increased through use of bulb supports or wells. Consult factory.



# TEMPERATURE TRANSMITTER

## Wall Mount for Building Applications

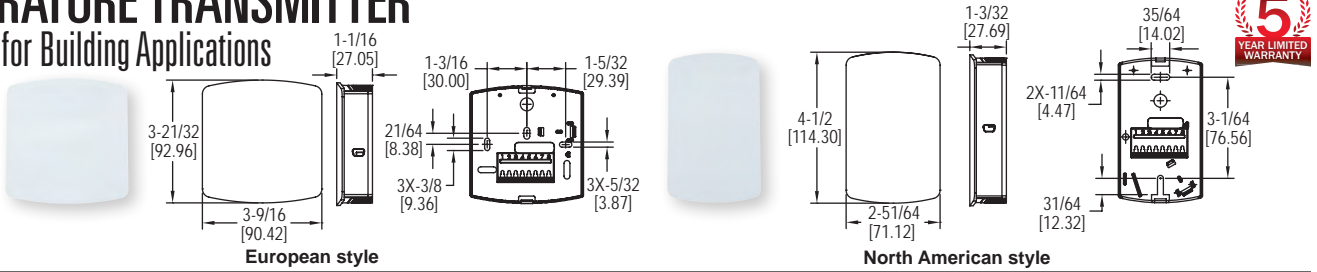

The Series BTT-E/N Temperature Transmitters offer transmitter output signals with the same form and fit as our popular Series TE-E/N thermistor and RTD sensors for Building Automation and HVAC installations.

### FEATURES/BENEFITS

- Transmitter signal offers reliable accuracy for installations with long wire runs between the transmitter and the receiver/controller

MODEL CHART		
Model	Housing	Output
BTT-N00-3	North American style	4-20 mA
BTT-N00-4	North American style	0-10 VDC
BTT-E00-3	European style	4-20 mA
BTT-E00-4	European style	0-10 VDC

### APPLICATIONS

- Room or indoor building space temperature monitoring

### SPECIFICATIONS

**Temperature Sensor:** Pt 1000 Ω RTD DIN Class A 0.00385Ω/°C.  
**Range:** 32 to 122 °F (0 to 50 °C).  
**Temperature Limits:** 32 to 122 °F (0 to 50 °C).  
**Accuracy:** ±0.5 °C @ 25 °C.  
**Thermal Effect:** ±0.01%/°C.  
**Response Time:** 100 ms.  
**Power Requirements:** 13-36 VDC for current models, 13-36 VDC or 16-28 VAC for voltage models.  
**Output Signal:** 4-20 mA or 0-10 VDC (depending on model).  
**Electrical Connections:** Screw terminal block.  
**Enclosure Rating:** IP20.  
**Weight:** 2.6 oz (73.7 g).  
**Agency Approvals:** CE.

## SERIES BTT

# TEMPERATURE TRANSMITTERS

## Current or Voltage Output, NEMA 4X Enclosures

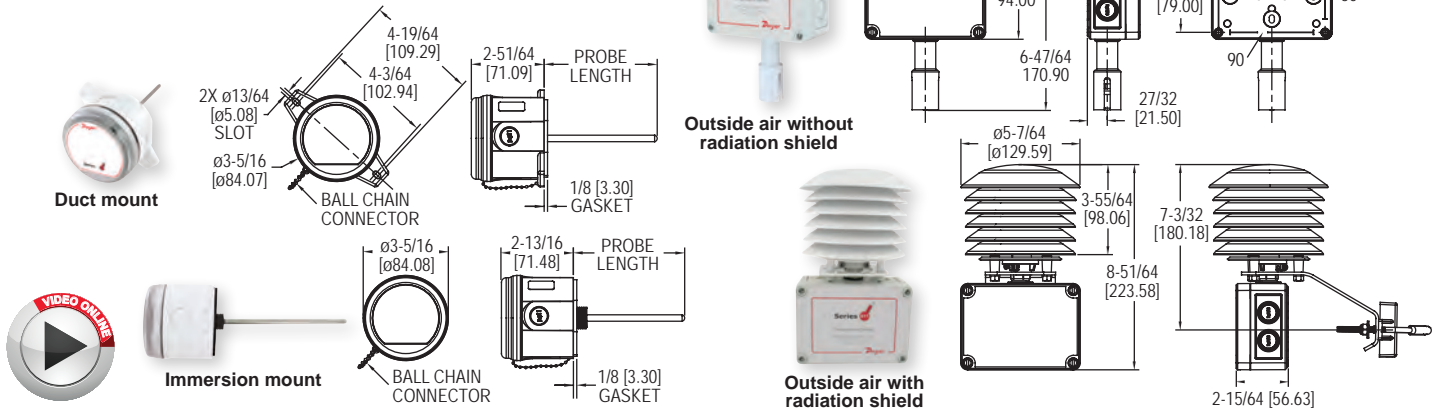

The Series BTT Temperature Transmitters offer transmitter output signals with the same form and fit as our popular TE thermistor and RTD sensors for building HVAC applications. Thermowells are required when using immersion models in liquid applications.

### FEATURES/BENEFITS

- Duct, immersion, and outside air models available
- Radiation shield available for mounting in direct sunlight
- Transmitter output allows for longer wire runs than standard thermistor sensors

### APPLICATIONS

- Building automation system temperature monitoring

MODEL CHART					
Example	BTT	-D	04	-1	BTT-D04-1
Series	BTT				Temperature transmitter
Mounting Configuration		D I O R			Duct mount Immersion mount Outside air Outside air with radiation shield
Probe Length*			25 04 06 08 12 18		2.5" (required for "O" and "R" models) 4" 6" 8" 12" 18"
Output				1 2	4 to 20 mA 0 to 10 V
Options				Blank FC NIST	None Factory calibration certificate NIST calibration certificate

\*For BTT-I models, actual probe length is approximately 0.75" longer than listed probe length to ensure maximum immersion into thermowells.

### SPECIFICATIONS

**Temperature Sensor:** Pt1000 RTD.  
**Range:** -40 to 140°F (-40 to 60°C).  
**Temperature Limits:** Operating: -40 to 302°F (-40 to 150°C).  
**Accuracy:** ±0.5°C @ 25°C.  
**Thermal Effect:** ±0.01%/°C.  
**Response Time:** 100 ms.  
**Wetted Materials:** All models: 304 SS (probe), polycarbonate (housing); Duct and immersion models: Neoprene (gasket); Outside air models: Nylon (insert), silicone (O-ring).  
**Process Connection:** 1/2" NPT (immersion models only).  
**Electrical Connection:** Removable terminal block, knocks out for conduit fitting.  
**Conduit Connection:** 1/2" NPT.  
**Probe Lengths:** 2.5 to 18" (depending on configuration).  
**Power Requirements:** 13-36 VDC for current models, 13-36 VDC or 16-28 VAC for voltage models.  
**Output Signal:** 4-20 mA or 0-10 VDC (depending on model).  
**Enclosure Rating:** NEMA 4X (IP66) (immersions models require thermowell).  
**Weight:** 5.11 oz (145 g) (duct/immersion); 8.4 oz (238 g) (OSA without radiation shield); 1 lb 7.4 oz (663.4 g) (OSA with radiation shield).  
**Agency Approvals:** CE.

THERMOWELLS - WELDED			
Model	Material	Connection (Internal/External)	Insertion Length
TE-TNS-N253N-00	304 SS	1/2" NPSM/1/2" NPT	2.5"
TE-TNS-N043N-00	304 SS	1/2" NPSM/1/2" NPT	4"
TE-TNS-N063N-00	304 SS	1/2" NPSM/1/2" NPT	6"
TE-TNS-N083N-00	304 SS	1/2" NPSM/1/2" NPT	8"
TE-TNS-N123N-00	304 SS	1/2" NPSM/1/2" NPT	12"
TE-TNS-N183N-00	304 SS	1/2" NPSM/1/2" NPT	18"

# WEATHERPROOF IMMERSION TEMPERATURE TRANSMITTER

Pt100 RTD, PC Programmable Transmitter

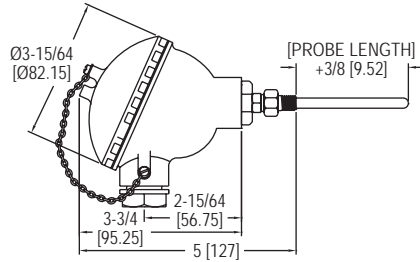

The **Series TTW Weatherproof Immersion Temperature Transmitter** offers a field adjustable temperature transmitter pre-assembled with an RTD sensor and weatherproof enclosure.

**FEATURES/BENEFITS**

- Preset to 32 to 212°F (0 to 100°C) output range
- USB port for easy output scale adjustment in the field

**APPLICATIONS**

- Immersion temperature sensing in HVAC systems

MODEL CHART	
Model	Probe Length
TTW-104	4"
TTW-106	6"
TTW-108	8"
TTW-112	12"
TTW-118	18"

**THERMOWELLS - MACHINED**

Model	Material	Length	Connection (Internal/External) (NPT)
TE-TNS-N044N-14	304 SS	4"	1/4" / 1/2"
TE-TNS-N064N-14	304 SS	6"	1/4" / 1/2"
TE-TNS-N094N-14	304 SS	9"	1/4" / 1/2"
TE-TNS-N124N-14	304 SS	12"	1/4" / 1/2"

**SPECIFICATIONS**

**TEMPERATURE SENSOR**

**Accuracy:** ±3°F (±1.7°C).  
**Temperature Limits:** Operating: -40 to 302°F (-40 to 150°C).  
**Sensor Curves:** Pt100 RTD (TE Series Curve D).

**TEMPERATURE TRANSMITTER**

**Input Range:** -328 to 986°F (-200 to 530°C).  
**Output:** Two-wire 4-20 mA.  
**Output Impedance:** 600 Ω @ 24 VDC.  
**Power Requirements:** 12-35 VDC.  
**Accuracy:** ±0.2% FS.  
**Temperature Limits:** -40 to 185°F (-40 to 85°C).  
**Response Time:** <100 ms.

**ENCLOSURE**

**Temperature Limits:** -40 to 212°F (-40 to 100°C).  
**Rating:** NEMA 4X (IP65).  
**Material:** Painted aluminum housing.

FREE software download: See page 134 (Series TBU-00)



Machined thermowell

Technical Specifications and Additional Thermowell Models: See page 147 (Series TE-TNS)

**MODEL TBU-00**

# TEMPERATURE TRANSMITTER

Field Selectable, Universal Input, In-Head Mounting

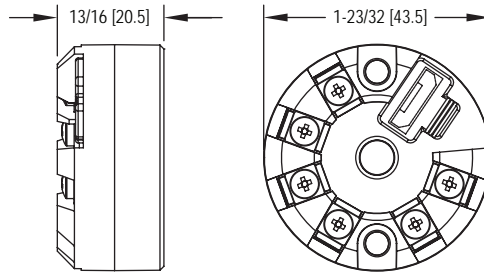

The **Model TBU-00 Temperature Transmitter** is a high precision temperature transmitter designed to easily mount in most temperature sensor instrument enclosures. The universal input reduces inventory while the micro-USB port facilitates easy configuration, and calibration in the lab or in the field. The versatile TBU model allows for selection and configuration of input type, measurement range, and calibration. The output can be set as either direct 4-20 mA, or reverse 20-4 mA, through easy to use configuration software.

**FEATURES/BENEFITS**

- Configurable measurement range
- Standard temperature sensor head enclosure mounting
- Pt100 connection for 2, 3, or 4 wires

**APPLICATIONS**

- Process applications where a 4-20 mA signal is required
- Food processing equipment
- Boiler equipment
- Refrigeration equipment

MODEL CHART	
Model	Description
TBU-00*	Universal input temperature transmitter with customizable measurement ranges

\*TBU-00 FREE downloadable configuration software available at [www.dwyer-inst.com](http://www.dwyer-inst.com)

**ACCESSORIES**

Model	Description
A-709	NEMA 4X aluminum transmitter enclosure
UHH-CBL2	USB to micro-USB cable

**SPECIFICATIONS**

**Input:** Thermocouples J, K, R, S, T, N, E, and B; 2, 3, or 4 wire Pt100 RTD, 2 or 3 wire Pt1000 RTD, 2 wire NTC thermistor, or 0-50 mV voltage.  
**Output:** Linearized 4-20 mA, 2 wire or 20-4 mA loop powered.  
**Transmitter Type:** 2, 3, or 4 wire.  
**Temperature Limits:** -40°F to 185°F (-40 to 85°C).  
**Power Requirements:** 10-35 VDC.  
**Accuracy:** See chart below.  
**Temperature Drift:** < ±0.16% / 25°C.  
**Response Time:** 1.6 s, typical.  
**Weight:** 1.4 oz (40 g).  
**Agency Approvals:** CE.

**Note:** Factory set to Pt100 Ω RTD, 0 to 100°C, direct acting

**ACCURACY CHART**

Input Type	Temperature Range	Accuracy (Typical)
Thermocouples and mV	Configured with software	±0.1% FS
Pt100/ Pt1000 RTDs	-328 to 1202°F (-200 to 650°C) -238 to 752°F (-150 to 400°C)	±0.13% FS ±0.1% FS



# EXPLOSION-PROOF RTD TEMPERATURE TRANSMITTER

User Selectable Ranges, Optional LCD Display



\*Shown with optional LCD display

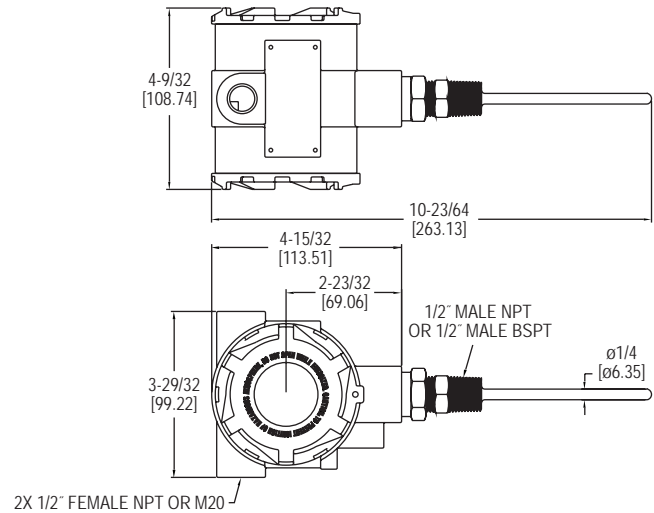

The **Series TTE Explosion-Proof RTD Temperature Transmitter** is the ideal product for hazardous temperature measurement applications. The TTE series has seven pre-programmed temperature ranges that are selectable via an internal dip switch. For those applications that need a custom range, the transmitter can be easily configured for any range between -30 to 250°F with a minimum span of 40°F. The span and zero can be quickly adjusted with a simple push-button design. This unit has optional listings of FM for use in Class I, Division 1, Groups B, C and D, Class II, Division 1, Groups E, F and G and Class III atmospheres or ATEX (Directive 2014/34/EU) for **CE** II 2 G Ex db IIC T6...T4 Gb (-20°C ≤ Ta ≤ +70°C), **CE** II 1 D Ex ta IIIC T111°C Da (-20°C ≤ Ta ≤ +70°C) and IECEx for Ex db IIC T6...T4 Gb (-20°C ≤ Ta ≤ +70°C), Ex ta IIIC T111°C Da (-20°C ≤ Ta ≤ +70°C). The compact housing allows for the transmitter to be mounted in virtually any application.

### FEATURES/BENEFITS

- FM approved for Class I, Groups B, C, D; Class II, Groups E, F, G classified explosive environments
- Optional LCD
- Output span selected from seven common ranges or user determined

### APPLICATIONS

- Explosive process environments
- Offshore HVAC monitoring

MODEL CHART						
Example	TTE	-1	04	-W	-LCD	TTE-104-W-LCD
Series	TTE					Explosion-proof RTD temperature transmitter
Agency		1				FM*
		2				ATEX/IECEX flameproof
Probe Length			02			2" probe
			04			4" probe
			06			6" probe
			09			9" probe
			12			12" probe
			15			15" probe
			18			18" probe
Construction				W		Well probe
Options					Blank	No LCD display
					BSPT	1/2" male BSPT process connection
					C5	C5-M housing paint specification
					LCD	LCD display
					M20	Female M20 thread electrical connection

\*Options that do not have ATEX and IECEx.

Attention: Units without the "2" suffix following "TTE" are not directive 2014/34/EU (ATEX) Compliant. These units are not intended for use in potentially hazardous atmospheres in the EU. These units may be CE marked for other directives of the EU.

### ACCESSORIES

Model	Description
A-287	Mounting bracket for pipe or surface mounting (Includes bracket and two 2" U-bolts)

### SPECIFICATIONS

**Temperature Sensor:** Pt1000, 0.00385 DIN.  
**Output Temperature Ranges:** User selectable – any range between -30 to 250°F with a minimum span of 40°F.  
**Temperature Limits:** Ambient: -4 to 158°F (-20 to 70°C); Process: -30 to 250°F (-34.4 to 120°C).  
**Accuracy:** Transmitter ±0.1% FS; Probe ±0.3% FS.  
**Thermal Drift Effects:** ±0.02%/°C max.  
**Response Time:** 250 ms.  
**Wetted Materials:** 316 SS.  
**Process Connection:** 1/2" male NPT or 1/2" male BSPT.  
**Conduit Connection:** 1/2" female NPT or M20.  
**Probe Length:** 2" to 18" (depending on model).  
**Pressure Limits:** 2000 psi (137.9 bar).  
**Power Requirements:** 10 to 35 VDC.  
**Output Signal:** 4 to 20 mA (two wire loop powered).  
**Optional Display:** 2 lines X 8 character LCD.  
**Enclosure Rating:** Weatherproof and Explosion-proof. Listed with FM for Class I, Division 1, Groups B, C and D, and dust-ignitionproof for Class II, Division 1, Groups E, F and G and Class III atmospheres.  
**ATEX Certified:** **CE** 0518 **Ex** II 2 G Ex db IIC T6...T4 Gb, **CE** II 1 D Ex ta IIIC T111°C Da, T6 Process Temp ≤80°C, Temperature Class T5 Process Temp ≤95°C, Temperature Class T4 Process Temp ≤120°C as defined on nameplate. EU-type Certificate No.: EMT17ATEX0021 X.  
 ATEX Standards: EN 60079-0:2012+A11:2013; EN 60079-1:2015; EN 60079-31:2014.  
**IECEX Certified:** For Ex db IIC T6...T4 Gb, Ex ta IIIC T111°C Da, T6 Process Temp ≤80°C, Temperature Class T5 Process Temp ≤95°C, Temperature Class T4 Process Temp ≤120°C as defined on nameplate.  
**IECEX Certificate of Conformity:** Element IECEx EMT 17.0007X; IECEx Standards: IEC 60079-0:2011 (Edition 6); IEC 60079-1:2014 (Edition 7); IEC 60079-31:2013 (Edition 2).  
**Weight:** 2 lb 8 oz (1134 g).  
**Agency Approvals:** FM, CE, ATEX/IECEX.

### THERMOWELLS - MACHINED

Model	Material	Length	Connection (Internal/External) (NPT)
TE-TNS-N044N-12	304 SS	4"	1/2" / 3/4"
TE-TNS-N064N-12	304 SS	6"	1/2" / 3/4"
TE-TNS-N094N-12	304 SS	9"	1/2" / 3/4"
TE-TNS-N124N-12	304 SS	12"	1/2" / 3/4"



Machined thermowell

### FIELD-SELECTABLE RANGES

40 to 90°F (4.4 to 32.2°C)  
 -20 to 140°F (-28.9 to 60°C)  
 0 to 100°F (-17.8 to 37.8°C)  
 30 to 240°F (-1.1 to 115.6°C)  
 32 to 212°F (0 to 100°C)  
 32 to 122°F (0 to 50°C)  
 -30 to 65°C (-1.1 to 18.3°C)  
 Custom range between -30 to 250°F (-34.4 to 121.1°C)

Technical Specifications and Additional Thermowell Models: See page 147 (Series TE-TNS)



# TEMPERATURE SENSORS

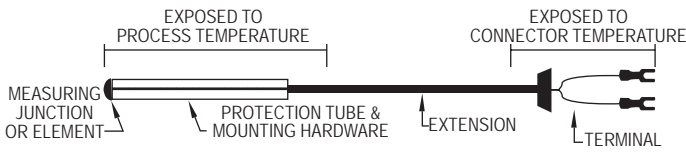

Thermocouple Types	Wire Types	Temperature Range (°F)	Temperature Range (°C)
J	Iron/constantan	32 to 1400	0 to 760
K	Chromel/alumel	32 to 2300	0 to 1200
E	Chromel/constantan	-300 to 1600	-184 to 871
T	Copper/constantan	-300 to 700	-184 to 371
R	Plat. 13%/rhod./plat.	32 to 2700	0 to 1482
S	Plat. 10%/rhod./plat.	32 to 2700	0 to 1482
RTD Types		Temperature Range (°F)	Temperature Range (°C)
	Low range thin film	-58 to 392	-50 to 200
	Medium range thin film	-58 to 896	-50 to 480
	High range wire wound	-328 to 1112	-200 to 600

## ORDERING SENSORS

Sensors are constructed with various types of protection/mounting hardware, extensions, and wire terminations. The sensor types and their temperature ranges are shown in the table. See "Temperature Limits" for maximum service temperatures applicable to the protection tube, mounting hardware, wire extensions, etc.

This section shows only a limited selection of the available sensors. The sensors are organized by hardware type. Most hardware can house any type thermocouple or RTD. Terminations are usually either lug type or standard plugs, but many other types are available. Various 'head enclosures' are also available. Dimensions can be custom designed to meet your specifications.

## SERVICE TEMPERATURES

304/316 SS tubing/protection/mounting hardware	1600°F
Inconel® 600 tubing/protection/mounting hardware	2100°F
Alumina	3400°F
Mullite	2700°F
Fiberglass insulated extension wire	842°F
FEP insulated extension wire	392°F
Junction box (BX) connector	400°F
Plug	400°F

## TEMPERATURE LIMITS

Sensor selection depends on two separate temperatures: process temperature and connector temperature. Make sure the local temperature at each component does not exceed the maximum rated service temperature for that component. Note that extension wire must withstand the process temperature.

## HARDWARE TYPE



## TERMINALS

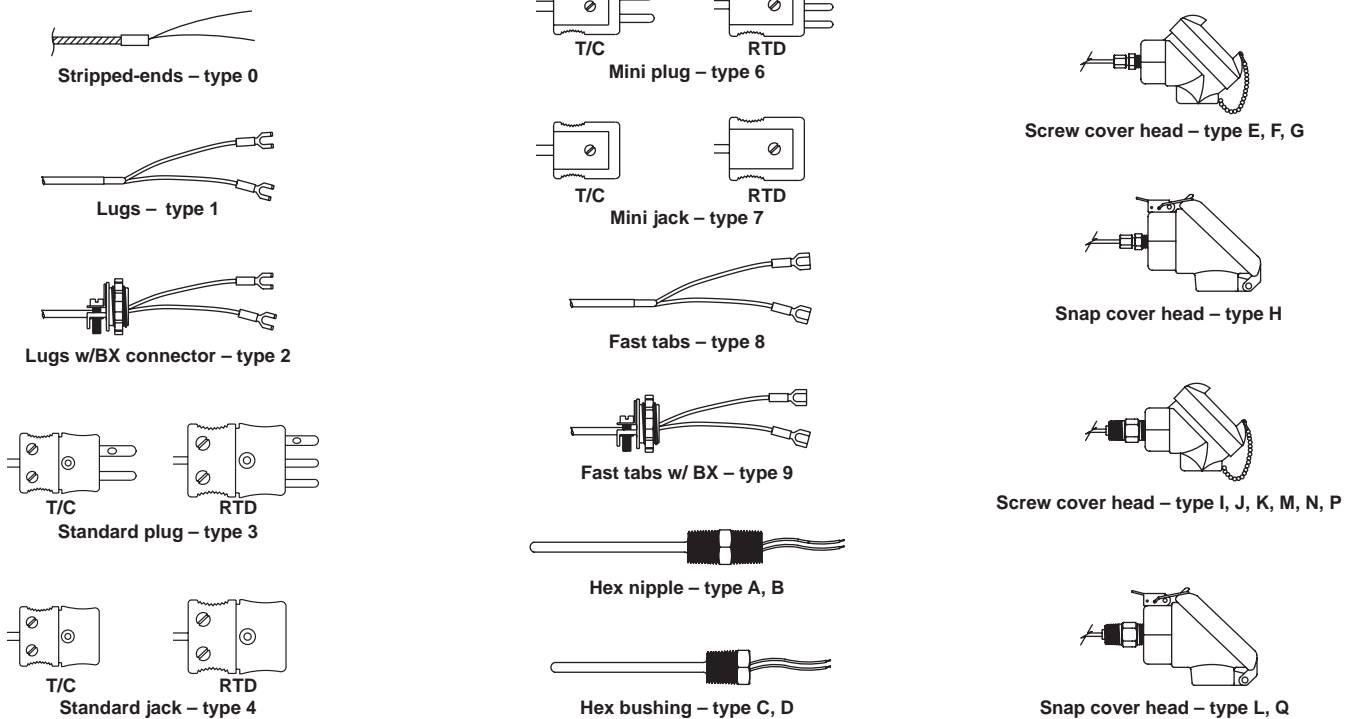

Inconel® is a registered trademark of Huntington Alloys Corporation





# THERMOCOUPLES & RTD'S

## GENERAL PURPOSE

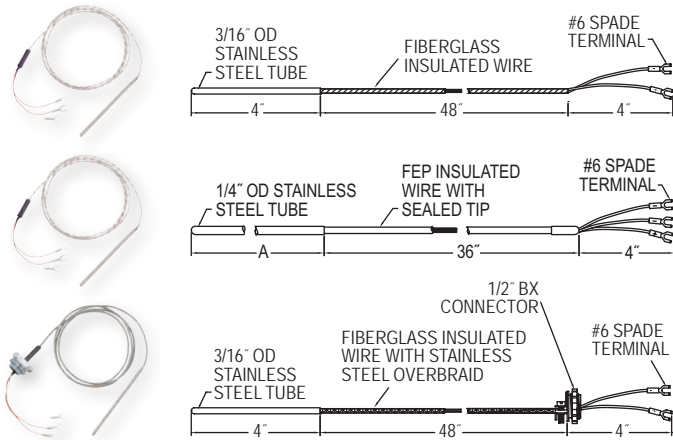

MODEL CHART - BASIC		
Model	Sensor Type	Terminal
122095-84	J	#6 spade
122095-01	K	#6 spade
122095-04	(3-wire) 100 Ω RTD	#6 spade

MODEL CHART - FEP INSULATION EXTENSION			
Model	Sensor Type	A Length	Terminal
122087-00	100 Ω RTD	6"	#6 spade

MODEL CHART - SS OVERBRAID EXTENSION			
Model	Sensor Type	Bend	Terminal
122095-19	J	0°	#6 spade
122095-25	100 Ω RTD	0°	#6 spade

## SPECIAL PURPOSE

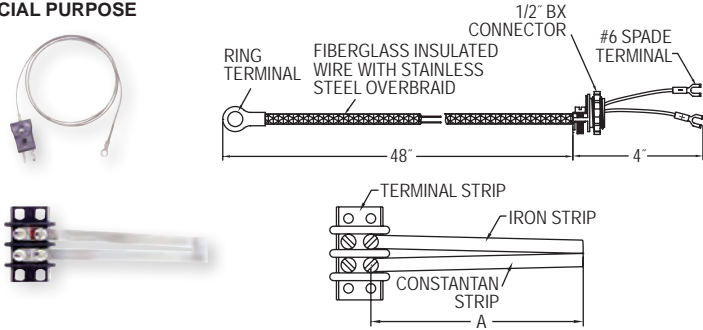

MODEL CHART - SURFACE THERMOCOUPLE (900°F MAX.)			
Model	Sensor Type	Ring Terminal ID	Terminal
122095-24	J	13/32"	#6 spade
122095-32	J	13/64"	#6 spade

MODEL CHART - WEB STYLE		
Model	A Length	Terminal
122095-86	2.75"	No

## MINERAL INSULATED

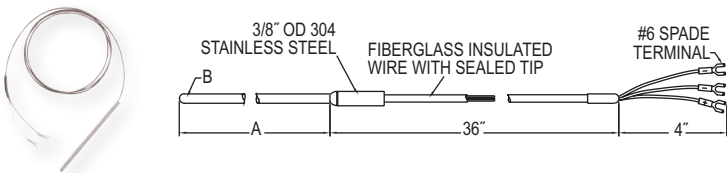

MODEL CHART				
Model	Sensor Type	A Length	B Diameter	Terminal
122088-00	100 Ω RTD	6"	1/4"	#6 spade
122088-01	100 Ω RTD	12"	1/4"	#6 spade
122086-00	100 Ω RTD	6"	1/8"	#6 spade

## SERIES RTD

# RESISTANCE TEMPERATURE DETECTOR

High Temperature, Mineral Insulated, 316 SS Sheath

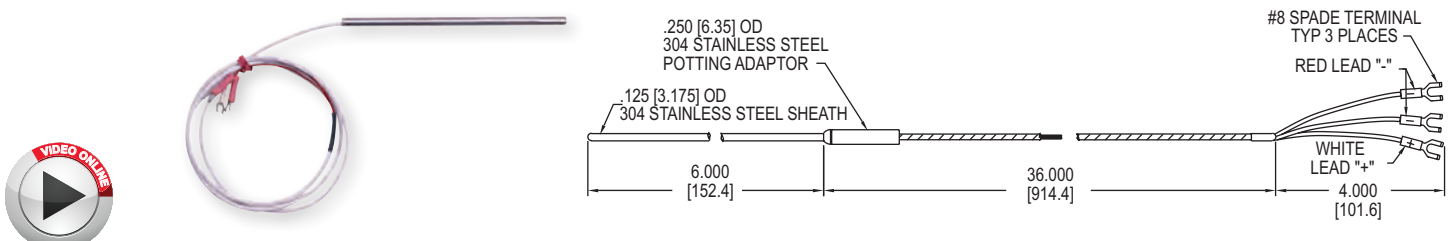

Precision **Series RTD Resistance Temperature Detector** offers excellent accuracy and stability over a wide temperature range. Industry standard 3-wire 100 Ω (DIN) probes are available in 6" (15 cm), 12" (30.5 cm), or 18" (46 cm) sheath lengths with 30" (76 cm) extension cable and spade lug terminals.

### FEATURES/BENEFITS

- 304 stainless steel sheath
- High temperature rating

### APPLICATIONS

Air ducts, bearing temperature, oil temperature indicator, soldering equipment, ovens, environmental test chambers, pharmaceutical mfg., food processing, plastic molding, petroleum & chemical processing, electric generating plants, etc.

### SPECIFICATIONS

**Sensor Type:** Wire wound, 100 Ω.  
**Temperature Range:** -328 to 1202°F (-200 to 650°C).  
**Pressure Limits:** 250 psig (17.2 bar).  
**Probe Material:** 316 SS.  
**Extension Length:** 30" (76 cm).  
**Element Standard:** DIN .00385 (Class B, 0.12%).

MODEL CHART		
Model	Length	Diameter
RTD-686	6" (15 cm)	1/8"
RTD-646	6" (15 cm)	1/4"

# THERMOCOUPLE WIRE



J type - FEP



J type - FB

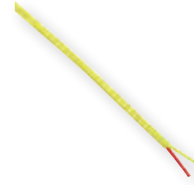

K type - FEP



K type - FB

**MODEL CHART - SPOOLS**

Model	Specification
A-TC-J25-FB	J type, 25' on spool, fiber glass insulation, 450°C, black outer sheath, 24 AWG, 0.20 SQMM
A-TC-J25-FEP	J type, 25' on spool, FEP insulation, 200°C, black outer sheath, 24 AWG, 0.20 SQMM
A-TC-K25-FB	K type, 25' on spool, fiber glass insulation, 450°C, yellow outer sheath, 24 AWG, 0.20 SQMM
A-TC-K25-FEP	K type, 25' on spool, FEP insulation, 200°C, yellow outer sheath, 24 AWG, 0.20 SQMM
A-TC-J50-FB	J type, 50' on spool, fiber glass insulation, 450°C, black outer sheath, 24 AWG, 0.20 SQMM
A-TC-J50-FEP	J type, 50' on spool, FEP insulation, 200°C, black outer sheath, 24 AWG, 0.20 SQMM
A-TC-K50-FB	K type, 50' on spool, fiber glass insulation, 450°C, yellow outer sheath, 24 AWG, 0.20 SQMM
A-TC-K50-FEP	K type, 50' on spool, FEP insulation, 200°C, yellow outer sheath, 24 AWG, 0.20 SQMM
A-TC-J100-FB	J type, 100' on spool, fiber glass insulation, 450°C, black outer sheath, 24 AWG, 0.20 SQMM
A-TC-J100-FEP	J type, 100' on spool, FEP insulation, 200°C, black outer sheath, 24 AWG, 0.20 SQMM
A-TC-K100-FB	K type, 100' on spool, fiber glass insulation, 450°C, yellow outer sheath, 24 AWG, 0.20 SQMM
A-TC-K100-FEP	K type, 100' on spool, FEP insulation, 200°C, yellow outer sheath, 24 AWG, 0.20 SQMM

**PLUGS (MALE)**



**MODEL CHART - STANDARD SIZE SINGLE**

Model	Type
481-0001	J
481-0002	K
481-0003	T
481-0004	Cu11 (2-wire)
481-0015	E
481-0134	Cu (3-wire)



**MODEL CHART - MINIATURE SIZE SINGLE**

Model	Type
481-0093	J
481-0095	K
481-0094	T
481-0098	R
481-0097	S
481-0096	E
481-0099	Cu (2-Wire)
481-0175	Cu (3-Wire)

**JACKS (FEMALE)**



**MODEL CHART - STANDARD SIZE SINGLE**

Model	Type
481-0006	J
481-0007	K
481-0008	T
481-0009	Cu11 (2-Wire)
481-0016	E
481-0135	Cu (3-Wire)



**MODEL CHART - MINIATURE SIZE SINGLE**

Model	Type
481-0100	J
481-0102	K
481-0101	T
481-0105	R
481-0104	S
481-0103	E
481-0106	Cu (2-Wire)
481-0174	Cu (3-Wire)

# MINERAL INSULATED THERMOCOUPLES AND RTD'S

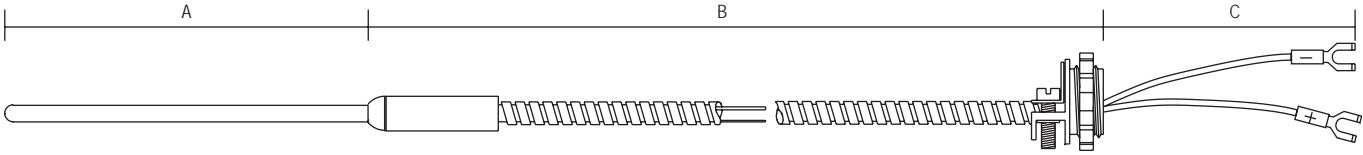

**MINERAL INSULATED TRANSITIONS**

Due to the varying size of connection wire and cable, a transition fitting is used between the cold end of the sheath and the connecting wires. This fitting measures 1-1/4" long by 1/4" OD for 1/8" or smaller sheaths, and 1-1/2" long by 3/8" OD for 3/16" and 1/4" sheaths. Larger sheaths and sheaths terminating in connectors other than wire or cable do not require transition fittings.

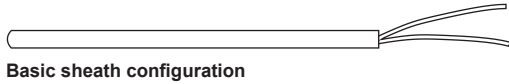

Basic sheath configuration

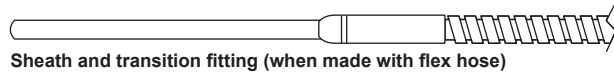

Sheath and transition fitting (when made with flex hose)



Sheath and transition fitting (when made with SS overbraid wire)



Sheath and transition fitting (when made with fiberglass wire)



Series R & 8 Mineral Insulated Thermocouples and RTD's are known for their excellent mechanical durability and resistance to electrical breakdown. Mineral Insulated Thermocouples can be bent to most any angle without special equipment.

**MODEL CODING**

Fill in the appropriate numbers or letters to specify the probe of your choice. Fill in all boxes. If an item or dimension does not apply, fill those boxes with zeros '0'.

		<b>RTD TYPE</b>											
		2 - 2-Wire; Class B											
		3 - 3-Wire; Class B											
		4 - 4-Wire; Class B											
		5 - 2-Wire; Class A											
		6 - 3-Wire; Class A											
		7 - 4-Wire; Class A											
<b>SENSOR TYPE</b>													
6 - 100 Ω RTD: 0.00385 Ω/°C													
4 - 100 Ω RTD: 0.00392 Ω/°C													
<b>R</b>	<input type="text"/>	<input type="text"/>	<input type="text"/>	<input type="text"/>	<input type="text"/>	<input type="text"/>	<input type="text"/>	<input type="text"/>	<input type="text"/>	<input type="text"/>	<input type="text"/>	<input type="text"/>	
<b>8</b>	<input type="text"/>	<input type="text"/>	<input type="text"/>	<input type="text"/>	<input type="text"/>	<input type="text"/>	<input type="text"/>	<input type="text"/>	<input type="text"/>	<input type="text"/>	<input type="text"/>	<input type="text"/>	
				<b>A</b>			<b>AA</b>			<b>B</b>		<b>C</b>	
				IN 1/10 INCH			IN 1/10 INCH			IN INCHES		IN INCHES	
<b>SENSOR TYPE</b>	<b>HARDWARE TYPE</b>	<b>EXTENSION TYPE</b>		<b>SENSOR TERMINALS</b>	<b>ELEMENTS</b>	<b>JUNCTION TYPE</b>	<b>SENSOR O.D.</b>	<b>BEND</b>					
J - T/C	1 - Plain Sheath (304 SS)	0 - Fiberglass Singles		0 - Stripped Ends	1 - Single	1 - Grounded	1 - 1/16"	1 - None					
K - T/C	2 - Plain Sheath (316 SS)	1 - Fiberglass Insulation		1 - Leads With #6 Spade Lugs	2 - Dual	2 - Ungrounded	2 - 1/8"	2 - 45°					
E - T/C	3 - Inconel® 600 Sheath	2 - Fiberglass Insulation w/ SS Flex Hose		2 - Leads With #6 Spade Lugs & 1/2 BX	3 - Exposed Tip	3 - Exposed Tip	3 - 3/16"	3 - 90°					
T - T/C		3 - Fiberglass Insulation w/ SS Overbraid		3 - Standard Plug			4 - 1/4"						
				4 - Standard Jack			5 - 3/8"						

**HEAD ASSEMBLY OPTIONS (3/4" NPT Conduit Connection)**

- E - Screw Cover Head, AL w/ No Process Connection
- F - Screw Cover Head, Plastic w/ No Process Connection
- G - Screw Cover Head, SS w/ No Process Connection
- H - Snap Cover Head, AL w/ No Process Connection
- I - Screw Cover Head, AL w/ 1/2" NPT Process Connection
- J - Screw Cover Head, Plastic w/ 1/2" NPT Process Connection
- K - Screw Cover Head, SS w/ 1/2" NPT Process Connection
- L - Snap Cover Head, AL w/ 1/2" NPT Process Connection
- M - Screw Cover Head, AL w/ 3/4" NPT Process Connection
- N - Screw Cover Head, Plastic w/ 3/4" Process Connection
- P - Screw Cover Head, SS w/ 3/4" Process Connection
- Q - Snap Cover Head, AL w/ 3/4" Process Connection

- 5 - Standard Plug
  - 6 - Mini Plug
  - 7 - Mini Jack
  - 8 - Leads With 1/4" Fastabs
  - 9 - Leads With 1/4" Fastabs 1/2" BX
  - A - 1/2" NPT Hex Nipple (316 SS)
  - B - 3/4" NPT Hex Nipple (316 SS)
  - C - 1/2" NPT Hex Bushing (316 SS)
  - D - 3/4 NPT Hex Bushing (316 SS)
- See table for **HEAD ASSEMBLY OPTIONS**

Inconel® is a registered trademark of Huntington Alloys Corporation

# GENERAL PURPOSE AND BAYONET TYPE THERMOCOUPLES & RTD'S

## GENERAL PURPOSE

## BAYONET

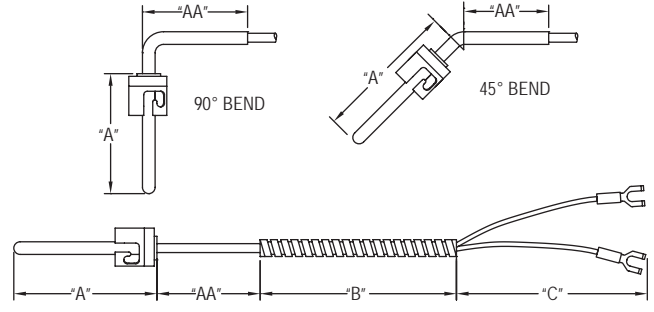
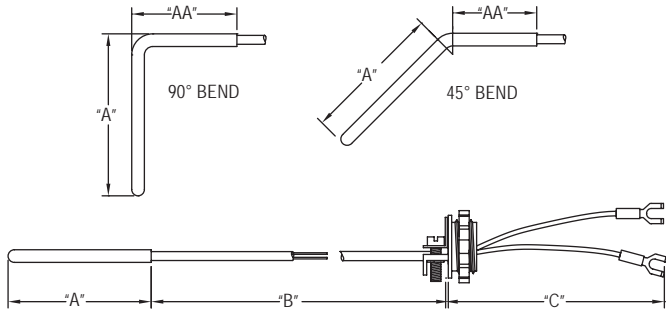

Series 4 & 5 General Purpose and Bayonet Type Thermocouples & RTD's tip temperatures can be as high as 842°F (450°C) for fiberglass insulated wire, and 392°F (200°C) for FEP insulated wire. Models can be specified with lead wires or head assembly construction. For higher temperatures see the Series R & 8 Mineral Insulated Probes. ●

### MODEL CODING

Fill in the appropriate numbers or letters to specify the probe of your choice. Fill in all boxes. If an item or dimension does not apply, fill those boxes with zeros '0'.

SENSOR TYPE		RTD TYPE		A IN 1/10 INCH			AA IN 1/10 INCH			B IN INCHES			C IN INCHES	
6 – 100 Ω RTD: 0.00385 Ω/°C		2 – 2-Wire; Class B												
Z – 1000 Ω RTD: 0.00385 Ω/°C		3 – 3-Wire; Class B												
4 – 100 Ω RTD: 0.00392 Ω/°C		5 – 2-Wire; Class A												
		6 – 3-Wire; Class A												

SENSOR TYPE	HARDWARE TYPE	EXTENSION TYPE	SENSOR TERMINALS	ELEMENTS	JUNCTION TYPE	SENSOR O.D.	BEND
J – T/C	1 – Plain Sheath (316 SS)	1 – Fiberglass Insulation 842°F/450°C	0 – Stripped Ends	1 – Single	1 – Grounded	2 – 1/8"	1 – None
K – T/C	2 – Plain Sheath w/ FEP Coating	2 – Fiberglass Insulation w/ SS Flex Hose	1 – Leads With #6 Spade Lugs	2 – Dual	2 – Ungrounded	3 – 3/16"	2 – 45°
E – T/C	4 – Back Filled Sheath*	3 – Fiberglass Insulation w/ SS Overbraid	2 – Leads With #6 Spade Lugs 1/2 BX	3 – Exposed Tip	3 – Exposed Tip	4 – 1/4"	3 – 90°
T – T/C	5 – Back Filled Sheath w/ FEP Coating*	4 – FEP Insulation 392°F/200°C	3 – Standard Plug			5 – 3/8"	
	6 – Bayonet Mount Adjustable Length	5 – FEP Insulation w/ SS Overbraid	4 – Standard Jack				
	7 – Bayonet Mount Fixed Length	6 – FEP Insulation w/ FEP Coated Flex Hose	6 – Mini Plug				

**HEAD ASSEMBLY OPTIONS\* (3/4" NPT Conduit Connection)**

- E – Screw Cover Head, AL w/ No Process Connection
- F – Screw Cover Head, Plastic w/ No Process Connection
- G – Screw Cover Head, SS w/ No Process Connection
- H – Snap Cover Head, AL w/ No Process Connection
- I – Screw Cover Head, AL w/ 1/2" NPT Process Connection
- J – Screw Cover Head, Plastic w/ 1/2" NPT Process Connection
- K – Screw Cover Head, SS w/ 1/2" NPT Process Connection
- L – Snap Cover Head, AL w/ 1/2" NPT Process Connection
- M – Screw Cover Head, AL w/ 3/4" NPT Process Connection
- N – Screw Cover Head, Plastic w/ 3/4" Process Connection
- P – Screw Cover Head, SS w/ 3/4" Process Connection
- Q – Snap Cover Head, AL w/ 3/4" Process Connection

\*Options only available on Series 4 RTD's

● See page 139 (Series R & 8)



# SPECIAL APPLICATION THERMOCOUPLES & RTD'S

## SERIES 9 SPECIALTY SENSOR STYLES

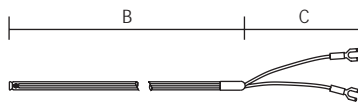

Flexible FEP covered bead junction

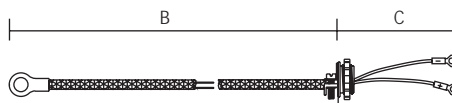

Ring type surface thermocouples and RTD's

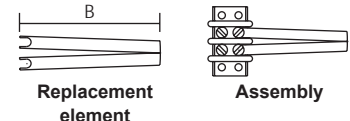

Replacement element  
Assembly  
Web type surface thermocouples

## SERIES P PENETRATION PROBE STYLES

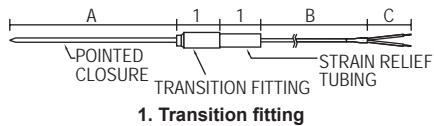

1. Transition fitting

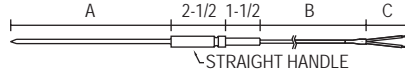

2. Straight handle

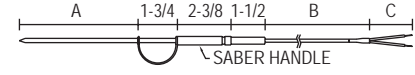

3. Saber handle

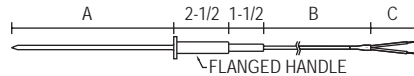

4. Flanged handle

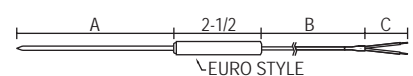

6&7. Euro style handle (FEP or SS)

Series 9 & P Special Application Thermocouples and RTD's cover a wide variety of types and configurations. This section covers FEP covered thermocouples and RTD's, ring type thermocouples and RTD's for surface measurement, web type thermocouples for surface measurement of moving objects such as rollers, and penetration thermocouples and RTD's with sharp tips for measurement of viscous liquids and semisolids such as plastic compounds, rubber and slightly frozen food products.

### MODEL CODING

Fill in the appropriate numbers or letters to specify the probe of your choice. Fill in all boxes. If an item or dimension does not apply, fill those boxes with zeros '0'.

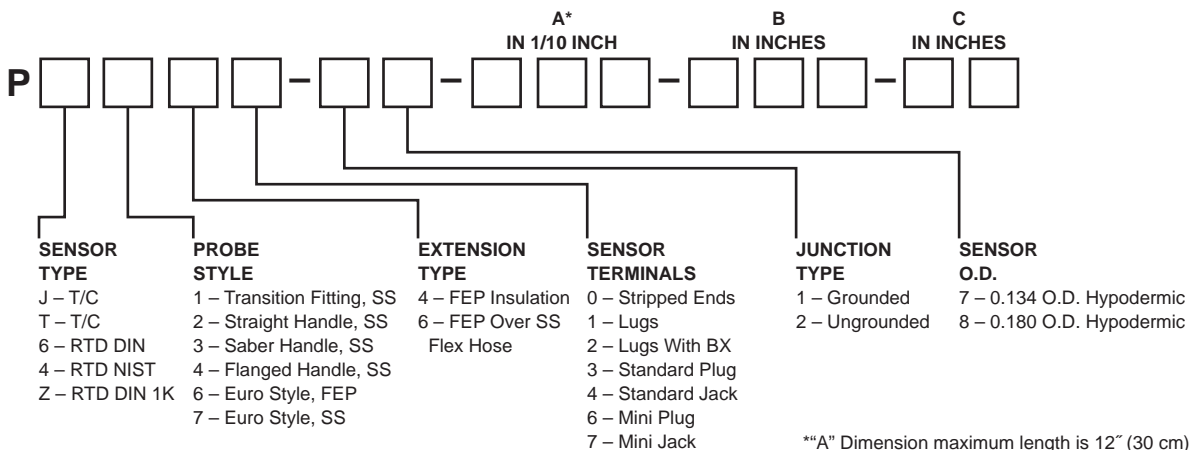
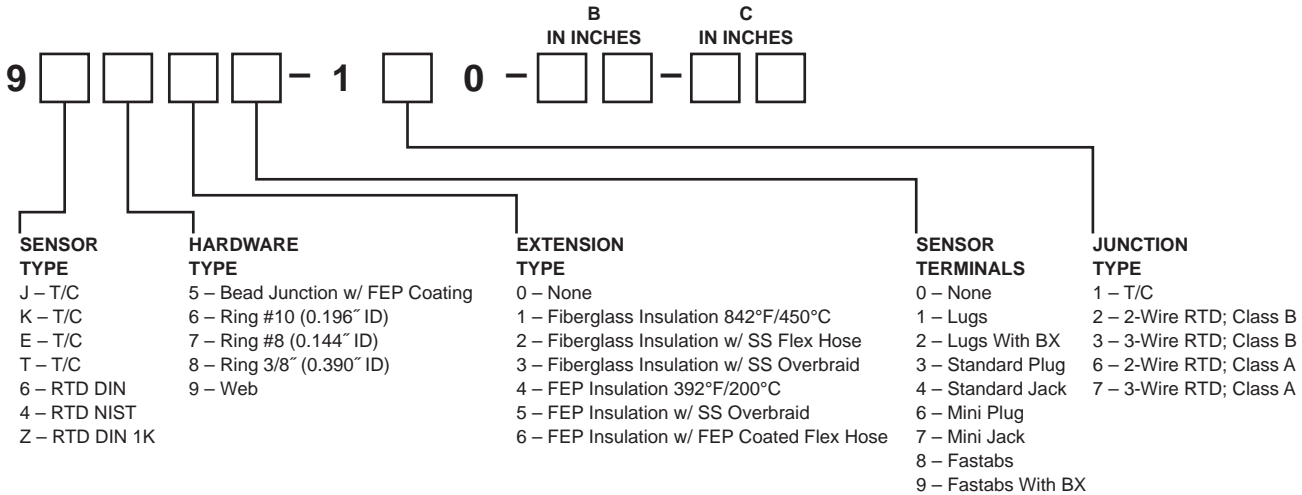

# TEMPERATURE SENSOR ASSEMBLIES WITH THERMOWELLS

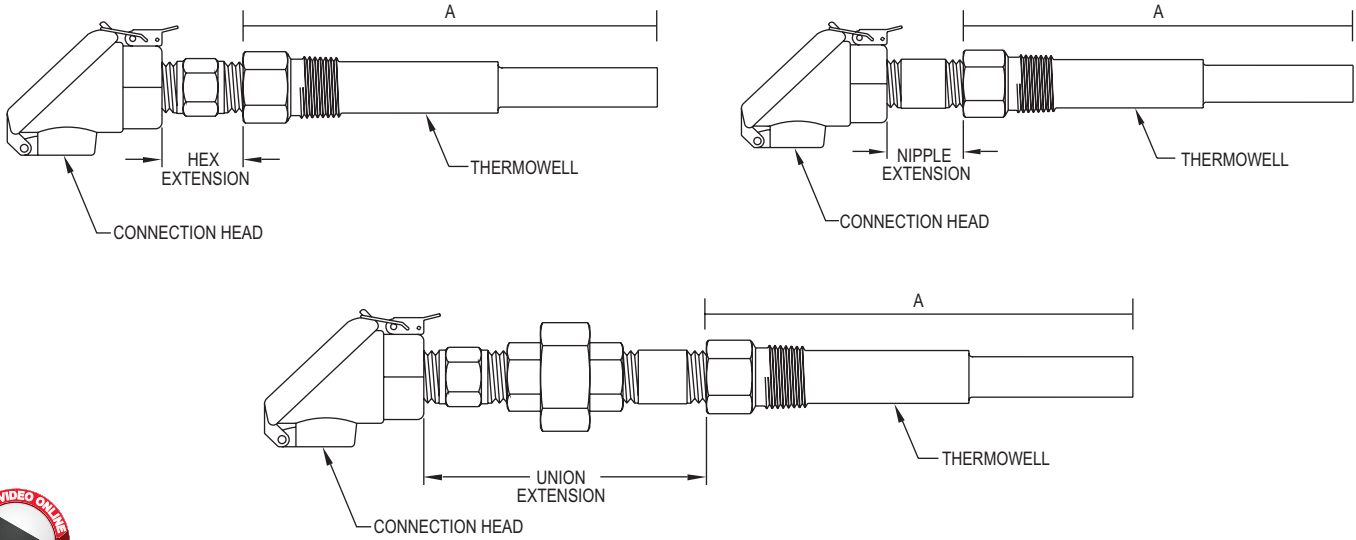

**Series T Temperature Sensor Assemblies with Thermowells** are available in a variety of head styles and thermowell materials. All elements are spring loaded to ensure positive contact in the thermowell. Thermowells are non-lagging. The sensor sheath material is constructed of 316 SS regardless of the well material specified.

**MODEL CODING**

Fill in the appropriate numbers or letters to specify the probe of your choice. Fill in all boxes. If an item or dimension does not apply, fill those boxes with zeros '0'.

A  
IN INCHES

SENSOR TYPE	WELL MATERIAL	TAPER/BORE	EXTENSION	ELEMENTS	HEAD	PROCESS CONNECTION (NOMINAL/REDUCED O.D.)
J - T/C	0 - None	0 - None	1 - Steel	1 - Single (Ungrounded/RTD)	0 - Aluminum Screw Cover	0 - None*
K - T/C	1 - 304 SS	1 - Step/0.260	1/2 NPT 1 in hex	2 - Dual (Ungrounded/RTD)	1 - Aluminum Snap Cover	1 - 1/2" NPT (5/8" to 1/2" Step)
E - T/C	2 - 316 SS	2 - Straight/0.385	4 - Steel	3 - Single (Grounded)	2 - Polypropylene Snap Cover	4 - 3/4" NPT (3/4" to 1/2" Step)
T - T/C	3 - Brass	3 - Taper/0.260	1/2 NPT 4 in nipple	4 - Dual (Grounded)	3 - Polypropylene Snap Cover	6 - 1" NPT (7/8" to 1/2" Step)
6 - 100 Ω RTD: 3-Wire 0.00385 Ω/°C	4 - Carbon Steel	4 - Taper/0.385	7 - Steel			7 - 3/4" NPT (7/8" to 5/8" Taper)
Z - 1000 Ω RTD: 3-Wire 0.00385 Ω/°C		5 - Straight/0.260	1/2 NPT 4 in union			8 - 1" NPT (1-1/16" to 5/8" Taper)
4 - 100 Ω RTD: 3-Wire 0.00392 Ω/°C			K - 316 SS 1/2 NPT 1 in hex N - 316 SS 1/2 NPT 4 in nipple S - 316 SS 1/2 NPT 4 in union			9 - 3/4" NPT (7/8" to 49/64" Taper)

\*For replacement sensors, specify "0" for well material, taper and bore, and process connections

# THERMOWELLS

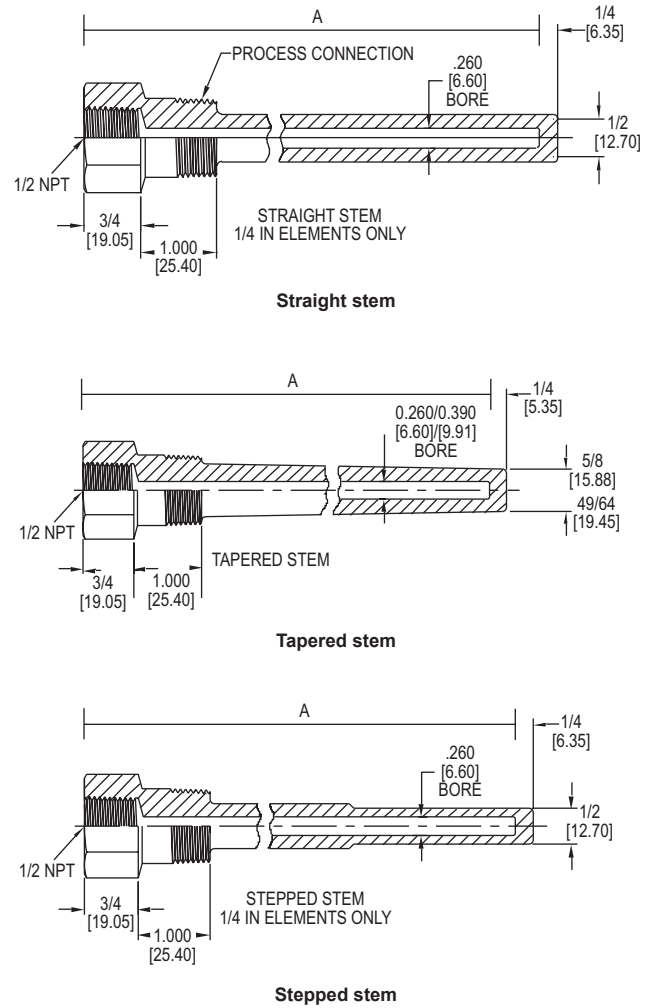
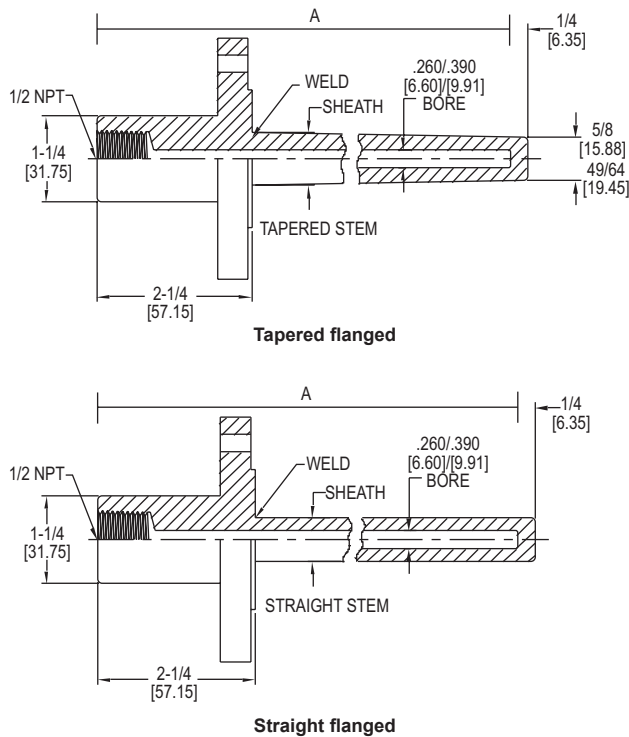

Select bore as 0.260 for 1/4" diameter elements and 0.390 for 3/8" diameter elements. Specify heavy duty mounting for tapered sheaths.

**MODEL CODING**

Fill in the appropriate numbers or letters to specify the thermowell of your choice. Fill in all boxes. If an item or dimension does not apply, fill those boxes with zeros '0'.

A  
IN INCHES

W     -    -

HARDWARE TYPE	TAPER/BORE	INSIDE THREAD	PROCESS CONNECTION	MOUNTING	LAG	SHEATH O.D. BASE / TAPER
1 - 304 SS Sheath	0 - Straight/0.260	1 - 1/2" Female NPT	1 - 1/2 NPT	1 - Threaded	0 - None	1 - 5/8" / 1/2" Step
2 - 316 SS Sheath	1 - Step/0.260		2 - 3/4 NPT	2 - Heavy Duty Threaded	2 - 2"	4 - 3/4" / 1/2" Step
3 - Brass	2 - Straight/0.390		3 - 1 NPT	3 - Heavy Duty Flanged	3 - 3"	6 - 7/8" / 1/2" Step
4 - Carbon Steel	3 - Taper/0.260		4 - 1" 150# Flange	4 - Flanged		7 - 7/8" / 5/8" Taper
	4 - Taper/0.390		5 - 1-1/2" 150# Flange			8 - 1-1/16" / 5/8" Taper
			6 - 2" 150# Flange			9 - 7/8" / 49/64" Taper
			7 - 1" 300# Flange			A - 1-1/16" / 49/64" Taper
			8 - 1-1/2" 300# Flange			B - 5/8" Straight
			9 - 2" 300# Flange			D - 7/8" Straight
			A - 1" 600# Flange			E - 3/4" Straight
			B - 1-1/2" 600# Flange			
			C - 2" 600# Flange			

USA: California Proposition 65  
 ⚠️ WARNING: Cancer and Reproductive Harm - www.P65Warnings.ca.gov



# THERMOCOUPLE ACCESSORIES

## EXTENSION CABLES

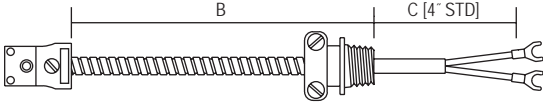

### MODEL CODING

Fill in the appropriate numbers or letters to specify the extension cable of your choice. Fill in all boxes. If an item or dimension does not apply, fill those boxes with zeros '0'.

**B**  
 IN FEET

**C (TERM. #1)**  
 IN INCHES

**C (TERM. #2)**  
 IN INCHES

**EC-**

<b>SENSOR TYPE</b> J – T/C K – T/C E – T/C T – T/C 2 – RTD 2-Wire 3 – RTD 3-Wire	<b>EXTENSION TYPE</b> 0 – No Extension 1 – Fiberglass Insulation 3 – Stainless Steel Overbraided 4 – FEP Insulation 5 – Stainless Steel Flex Hose 6 – FEP Over SS Flex Hose	<b>TERMINAL #1</b> 0 – Stripped Ends 1 – Lugs 2 – Lugs With BX 3 – Standard Plug 4 – Standard Jack 6 – Mini Plug 7 – Mini Jack 9 – Fastabs A – Fastabs With BX	<b>TERMINAL #2</b> 0 – Stripped Ends 1 – Lugs 2 – Lugs With BX 3 – Standard Plug 4 – Standard Jack 6 – Mini Plug 7 – Mini Jack 9 – Fastabs A – Fastabs With BX	<b>ELEMENTS</b> 1 – Single 2 – Dual
--	---	---	---	---

## COMPRESSION FITTINGS

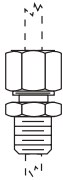

MODEL CHART							
Model	Type OD	Thread Size	Material	Model	Type OD	Thread Size	Material
144-0012	1/8"	1/8-27 NPT	Brass	144-0014	1/4"	1/4-18 NPT	Brass
144-0020	1/8"	1/8-27 NPT	Stainless steel	144-0024	1/4"	1/8-27 NPT	Stainless steel
144-0009	3/16"	1/8-27 NPT	Brass	144-0037	.260 - .275"	1/4-18 NPT	FEP
144-0022	3/16"	1/8-27 NPT	Stainless steel				

## PIPE ADAPTERS

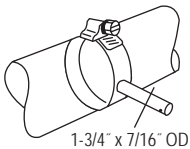

MODEL CHART					
Model	Fits Pipe Diameters	Model	Fits Pipe Diameters	Model	Fits Pipe Diameters
1568-0007	1/2" to 7/8"	1568-0013	4-5/16" to 5-1/4"	1568-0024	15-3/4" to 16-1/4"
1568-0008	7/8" to 1-1/2"	1568-0020	6-1/4" to 6-3/4"	1568-0025	17-3/4" to 18-1/4"
1568-0009	1-5/16" to 2-1/4"	1568-0021	7-3/4" to 8-1/4"	1568-0027	19-3/4" to 20-1/4"
1568-0011	2-1/4" to 3-5/16"	1568-0022	9-3/4" to 10-1/4"	1568-0028	23-3/4" to 24-1/4"
1568-0012	3-5/8" to 4-1/4"	1568-0023	11-3/4" to 12-1/4"	1568-0029	29-3/4" to 30-1/4"

## BAYONET ADAPTERS

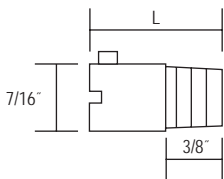

MODEL CHART		
Model	L	Thread Size
1568-0001	7/8"	1/8-27 UNF
1568-0002	7/8"	3/8-24 UNF
1568-0003	1-3/8"	1/8-27 UNF
1568-0004	1-3/8"	3/8-24 UNF
1568-0005	2-1/2"	1/8-27 UNF
1568-0006	2-1/2"	3/8-24 UNF
1568-0016	2-1/2"	10 x 1.5 mm

## TRANSITION ADAPTERS

These adapters convert the miniature plug on the end of the coiled cable on the Master Probe Handle to a standard lug. Simply plug the cord into the adapter.

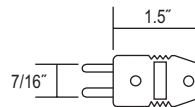

MODEL CHART	
Model	Type
481-0127	K
481-0126	J
481-0128	T

USA: California Proposition 65  
 ⚠️WARNING: Cancer and Reproductive Harm - www.P65Warnings.ca.gov



# WALL MOUNT TEMPERATURE SENSORS

## Discrete Wall Mount Housing



European

North American

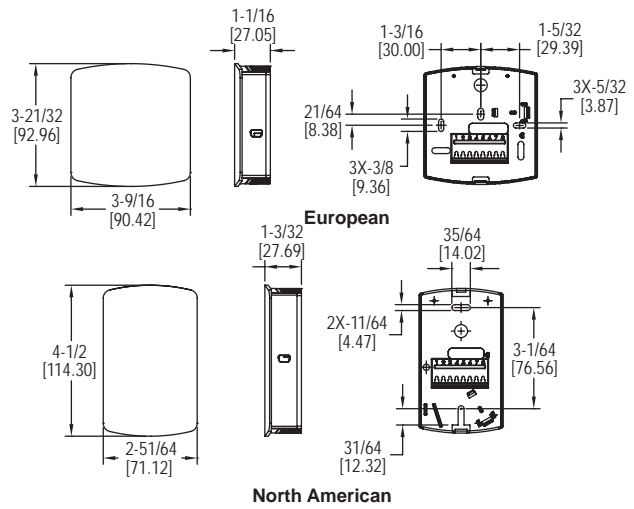

The Series TE-E/N Wall Mount Temperature Sensors provide a low cost temperature input for any building management system.

### FEATURES/BENEFITS

- North American or European housing aesthetic options
- Uniform look matches other Dwyer wall mount devices
- Universal mounting plate meets various installation requirements

### APPLICATIONS

- Building automation
- Room temperature monitoring

MODEL CHART			
North American Model	Sensor Type	European Model	Sensor Type
TE-NND-A	10k Ω type III thermistor	TE-END-A	10k Ω type III thermistor
TE-NND-B	10k Ω type II thermistor	TE-END-B	10k Ω type II thermistor
TE-NND-C	3k Ω thermistor	TE-END-C	3k Ω thermistor
TE-NND-D	Pt100 Ω RTD	TE-END-D	Pt100 Ω RTD
TE-NND-E	Pt1000 Ω RTD	TE-END-E	Pt1000 Ω RTD
TE-NND-F	20k Ω thermistor	TE-END-F	20k Ω thermistor

### SPECIFICATIONS

**Accuracy:** Thermistor temp sensor:  $\pm 0.22^{\circ}\text{C}$  @  $25^{\circ}\text{C}$  ( $\pm 0.4^{\circ}\text{F}$  @  $77^{\circ}\text{F}$ ); RTD temp sensor: DIN class B;  $\pm 0.3^{\circ}\text{C}$  @  $0^{\circ}\text{C}$  ( $\pm 0.5^{\circ}\text{F}$  @  $32^{\circ}\text{F}$ ).  
**Temperature Limits:** -40 to  $140^{\circ}\text{F}$  (-40 to  $60^{\circ}\text{C}$ ).  
**Housing Material:** ABS plastic.  
**Weight:** 0.3 lb (136 g).

## SERIES TE-WSS

# STAINLESS STEEL WALL PLATE TEMPERATURE SENSOR

Screw Terminal Connection, Suitable for Wash Down Applications

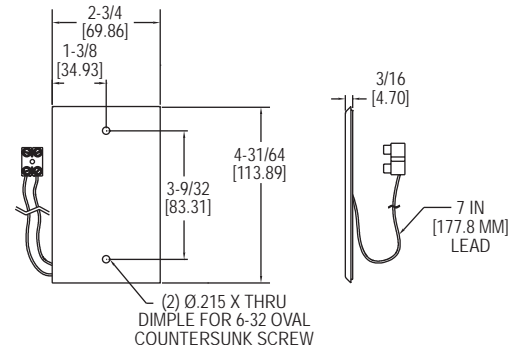

The Series TE-WSS Stainless Steel Wall Plate Temperature Sensor measures the ambient air temperature in classrooms and industrial environments.

### FEATURES/BENEFITS

- SS flush plate design
- Standard single gang junction box cover plate mounting

### APPLICATIONS

- Building automation
- Room temperature monitoring
- Wash down environments

### SPECIFICATIONS

**Accuracy:** Thermistor:  $\pm 0.22^{\circ}\text{C}$  @  $25^{\circ}\text{C}$  ( $\pm 0.4^{\circ}\text{F}$  @  $77^{\circ}\text{F}$ ); RTD: DIN Class B  $\pm 0.3^{\circ}\text{C}$  @  $0^{\circ}\text{C}$ .  
**Temperature Limits:** Operating -40 to  $140^{\circ}\text{F}$  (-40 to  $60^{\circ}\text{C}$ ).  
**Sensor Curves:** See page reference 1 below.  
**Housing Material:** 304 SS wall plate.  
**Weight:** 2.3 oz (65 g).

MODEL CHART	
Model	Sensor Type
TE-WSS-A	10k Ω type III thermistor
TE-WSS-B	10k Ω type II thermistor
TE-WSS-C	3k Ω thermistor
TE-WSS-D	PT100 Ω RTD
TE-WSS-E	PT1000 Ω RTD
TE-WSS-F	20k Ω thermistor

●Resistance vs. Temperature Table: See page 148 (Series TE-OND/RND/OSA)

# DUCT AND IMMERSION BUILDING AUTOMATION TEMPERATURE SENSORS

Available up to 18" Probe Length, Thermistor or RTD Outputs

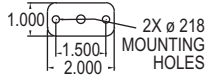
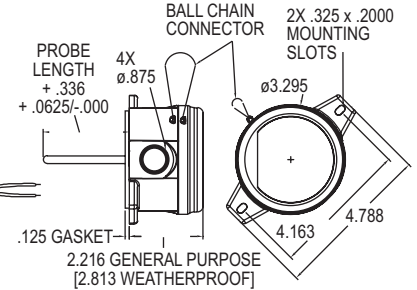
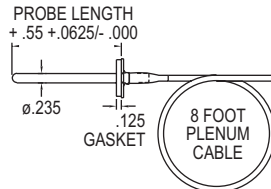
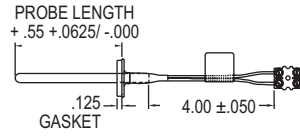
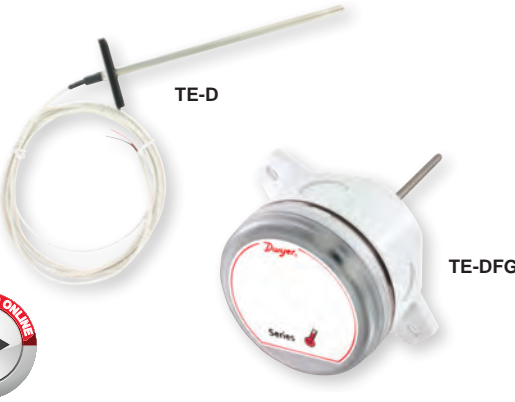
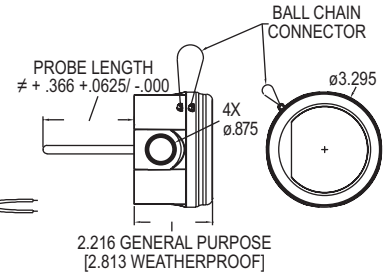
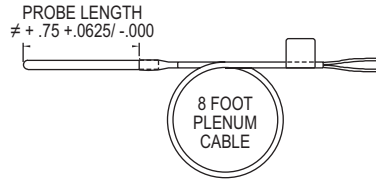
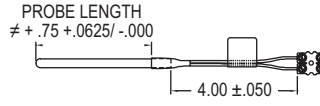

The **Series TE Duct and Immersion Building Automation Temperature Sensors** can be used to monitor air or water temperature throughout a building management system or an air handler unit. Duct or immersion options available with or without an enclosure.

**FEATURES/BENEFITS**

- Easy to mount external tab housing and flange options for duct applications
- 1/4 turn housing cover with chain to prevent dropping
- Multiple conduit knockouts for easy installation positioning
- 8" plenum rated cable option
- Terminal connector eliminates need for wire nuts

**APPLICATIONS**

- Building automation
- VAV temperature sensing
- Chiller or boiler loops
- AHU monitoring

**SPECIFICATIONS**

**Accuracy:** Thermistor temperature sensor:  $\pm 0.22^{\circ}\text{C}$  @  $25^{\circ}\text{C}$  ( $\pm 0.4^{\circ}\text{F}$  @  $77^{\circ}\text{F}$ ); RTD temperature sensor: DIN class A:  $\pm 0.15^{\circ}\text{C}$  @  $0^{\circ}\text{C}$  ( $\pm 0.28^{\circ}\text{F}$  @  $32^{\circ}\text{F}$ ).  
**Temperature Limits:** Operating:  $-40$  to  $302^{\circ}\text{F}$  ( $-40$  to  $150^{\circ}\text{C}$ ).  
**Sensor Curves:** See page reference 1 below.  
**Cable Rating:** Plenum option includes UL listed plenum cable.  
**Housing Material:** Meets UL, 94 V-0 polycarbonate plastic.  
**Housing Rating:** NEMA 4X (IP66) (DFW, IBW only).  
**Weight:** 5.3 oz (150.3 g).  
**Agency Approvals:** Meets the technical requirements of EU Directive 2011/65/EU (RoHS II).

MODEL CHART										
Example	TE	-DFN	-A	04	4	8	-00	TE-DFN-A0448-00		
Series	TE							Temperature sensor		
Mounting Configuration	DFN	DFG	DFW	IBN	IBG	IBW		Duct mount probe only Duct mount probe in general purpose housing Duct mount probe in NEMA 4X housing Immersion probe only Immersion probe in general purpose housing Immersion probe in NEMA 4X housing		
Sensor Type			A	B	C	D	E	F	Q	10k $\Omega$ type III thermistor 10k $\Omega$ type II thermistor 3k $\Omega$ thermistor Pt100 $\Omega$ RTD Pt1000 $\Omega$ RTD 20k $\Omega$ thermistor 10k $\Omega$ type III with 11k $\Omega$ shunt
Probe Length				25	04	06	08	12	18	2.5" 4" 6" 8" 12" 18" (DFN/DFG only)
Probe Diameter					4	5				1/4" 1/4" double encapsulated
Termination						3	4	7	8	4" leads with spade connectors 4" leads 8" plenum rated cable with spade connectors 8" plenum rated cable
Fittings							00	12	14	None (probe only) 1/2" NPT compression fitting 1/4" NPT compression fitting

●Resistance vs. Temperature Table: See page 162 (Series TE-OND/RND/OSA)

# IMMERSION TEMPERATURE SENSORS

## Integral Mounting Connection, Welded Thermowells

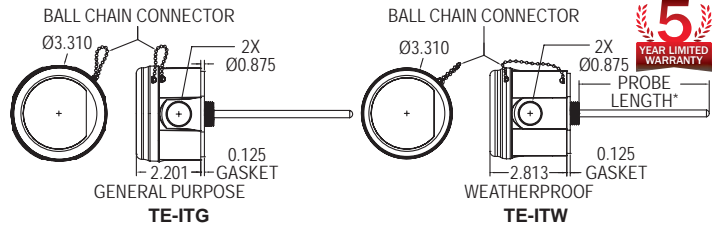

The Series TE-I Immersion Style Temperature Sensors accurately measure water temperature inside chilled and hot water loops in HVAC systems. Thermowells are required to protect the electrical connection from the process water and to allow replacement of the sensors without draining the system.

### FEATURES/BENEFITS

- Integral 1/2" NPSM connection for direct mounting to a thermowell
- 1/4 turn housing cover with chain to prevent dropping
- Multiple conduit knockouts for easy installation positioning
- General purpose or weatherproof enclosure options
- Terminal connection eliminates need for wire nuts

### APPLICATIONS

- Chiller or boiler loops
- Building automation

### SPECIFICATIONS

**Accuracy:** Thermistor temperature sensor:  $\pm 0.22^{\circ}\text{C}$  @  $25^{\circ}\text{C}$  ( $\pm 0.4^{\circ}\text{F}$  @  $77^{\circ}\text{F}$ ); RTD temperature sensor DIN Class A:  $\pm 0.15^{\circ}\text{C}$  @  $0^{\circ}\text{C}$  ( $\pm 0.28^{\circ}\text{F}$  @  $32^{\circ}\text{F}$ ).  
**Temperature Limits:** Operating:  $-40$  to  $302^{\circ}\text{F}$  ( $-40$  to  $150^{\circ}\text{C}$ ).  
**Sensor Curves:** See page reference below.  
**Housing Material:** Meets UL, 94 V-0 polycarbonate plastic.  
**Thermowell Material:** 304 SS.  
**Thermowell Connections:** Internal = 1/2" NPSM; External = 1/2" NPT.  
**Weight:** 5.3 oz (150.3 g).

MODEL CHART									
<b>Example</b>	TE	-ITG	-A	25	4	4	-00	TE-ITG-A2544-00	
<b>Series</b>	TE Duct and immersion building automation temperature sensor								
<b>Mounting Configuration</b>	ITG Immersion in general purpose housing ITW Immersion in NEMA 4X housing								
<b>Sensor Type</b>	A 10k $\Omega$ type III thermistor B 10k $\Omega$ type II thermistor C 3k $\Omega$ thermistor D Pt100 $\Omega$ RTD E Pt1000 $\Omega$ RTD F 20k $\Omega$ thermistor G 10k $\Omega$ type III with 11k $\Omega$ shunt Q								
<b>Probe Length*</b>	25 2.5" 04 4" 06 6" 08 8" 12 12" 18 18"								
<b>Probe Diameter</b>	4 1/4" 5 1/4" double encapsulated								
<b>Termination</b>	4 4" flying leads terminal block								
<b>Fittings</b>	00 None (integral)								
*Actual probe length is approximately 0.75" longer than listed probe length to ensure maximum immersion into thermowells.									

● Resistance vs. Temperature Table: See page 148 (Series TE-OND/RND/OSA)

### TE-TNS

# THERMOWELLS

## Thermowells for Building Automation Temperature Sensors



Fabricated (welded) thermowell

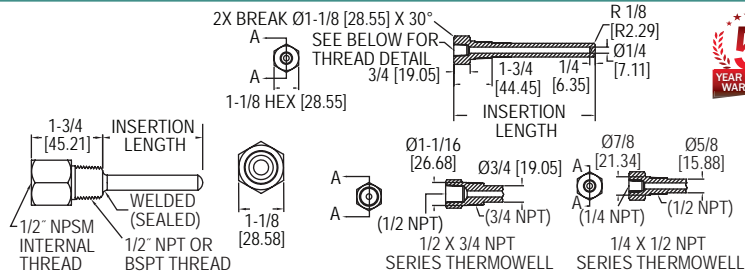

The Series TE-TNS Stainless Steel Thermowells are used to separate the instrument from the surrounding media. When used with the Series TE and TE-I Immersion Temperature Sensors, further protection is offered from aggressive media, high pressures, and flow rates while allowing for quick and easy installation of temperature sensors without having to drain process media. Thermowells are offered in both 304 and 316 stainless steel allowing for superior corrosion resistance. Fabricated, or welded, thermowells are constructed from a tube that is closed at the tip by a welded solid tip. Solid-machined thermowells are manufactured from barstock.

### FEATURES/BENEFITS

- Configurable materials and sizes
- Fabricated (welded) or machined construction
- 1/2" or 3/4" NPT process connections

### APPLICATIONS

- Building automation
- Chiller or boiler loops
- Chemical industry or process technology

MODEL CHART						
<b>Example</b>	TE-TNS	-N	9	5N	-14	TE-TNS-N095N-14
<b>Series</b>	TE-TNS					Stainless steel thermowell
<b>Thread Type</b>	N					NPT
<b>Length</b>	2.5 04 06 09 12 18					2.5" 4" 6" 9" 12" 18"
<b>Material &amp; Construction</b>	3N 4N 5N					304 SS fabricated (welded) 304 SS machined 316 SS machined
<b>Connection (Internal &amp; External)</b>	00 12 14					1/2" NPSM / 1/2" NPT 1/2" NPT / 3/4" NPT 1/4" NPT / 1/2" NPT

### SPECIFICATIONS

**Maximum Pressure:** Fabricated: 140 psi; Machined: 304 SS: 3700 psi; 316 SS: 5500 psi.  
**Maximum Temperature:** Fabricated: 1000°F (538°C); Machined: 1200°F (648°C).  
**Construction:** Fabricated (welded) or machined model specific.

### MODEL CHART

Model	Material	Length	Construction	Connection (Internal/External)
TE-TNS-N044N-14	304 SS	4"	Machined	1/4" NPT / 1/2" NPT
TE-TNS-N044N-12	304 SS	4"	Machined	1/2" NPT / 3/4" NPT
TE-TNS-N064N-14	304 SS	6"	Machined	1/4" NPT / 1/2" NPT
TE-TNS-N064N-12	304 SS	6"	Machined	1/2" NPT / 3/4" NPT
TE-TNS-N094N-14	304 SS	9"	Machined	1/4" NPT / 1/2" NPT
TE-TNS-N094N-12	304 SS	9"	Machined	1/2" NPT / 3/4" NPT
TE-TNS-N124N-14	304 SS	12"	Machined	1/4" NPT / 1/2" NPT
TE-TNS-N124N-12	304 SS	12"	Machined	1/2" NPT / 3/4" NPT
TE-TNS-N045N-14	316 SS	4"	Machined	1/4" NPT / 1/2" NPT
TE-TNS-N045N-12	316 SS	4"	Machined	1/2" NPT / 3/4" NPT
TE-TNS-N065N-14	316 SS	6"	Machined	1/4" NPT / 1/2" NPT
TE-TNS-N065N-12	316 SS	6"	Machined	1/2" NPT / 3/4" NPT
TE-TNS-N095N-14	316 SS	9"	Machined	1/4" NPT / 1/2" NPT
TE-TNS-N095N-12	316 SS	9"	Machined	1/2" NPT / 3/4" NPT
TE-TNS-N125N-14	316 SS	12"	Machined	1/4" NPT / 1/2" NPT
TE-TNS-N125N-12	316 SS	12"	Machined	1/2" NPT / 3/4" NPT
TE-TNS-N253N-00	304 SS	2.5"	Fabricated	1/2" NPSM / 1/2" NPT
TE-TNS-N043N-00	304 SS	4"	Fabricated	1/2" NPSM / 1/2" NPT
TE-TNS-N063N-00	304 SS	6"	Fabricated	1/2" NPSM / 1/2" NPT
TE-TNS-N083N-00	304 SS	8"	Fabricated	1/2" NPSM / 1/2" NPT
TE-TNS-N123N-00	304 SS	12"	Fabricated	1/2" NPSM / 1/2" NPT
TE-TNS-N183N-00	304 SS	18"	Fabricated	1/2" NPSM / 1/2" NPT



SERIES TE-OND/TE-RND/TE-OSA

# OUTDOOR TEMPERATURE SENSORS

Protection Against Radiated Heat, Weatherproof Housing

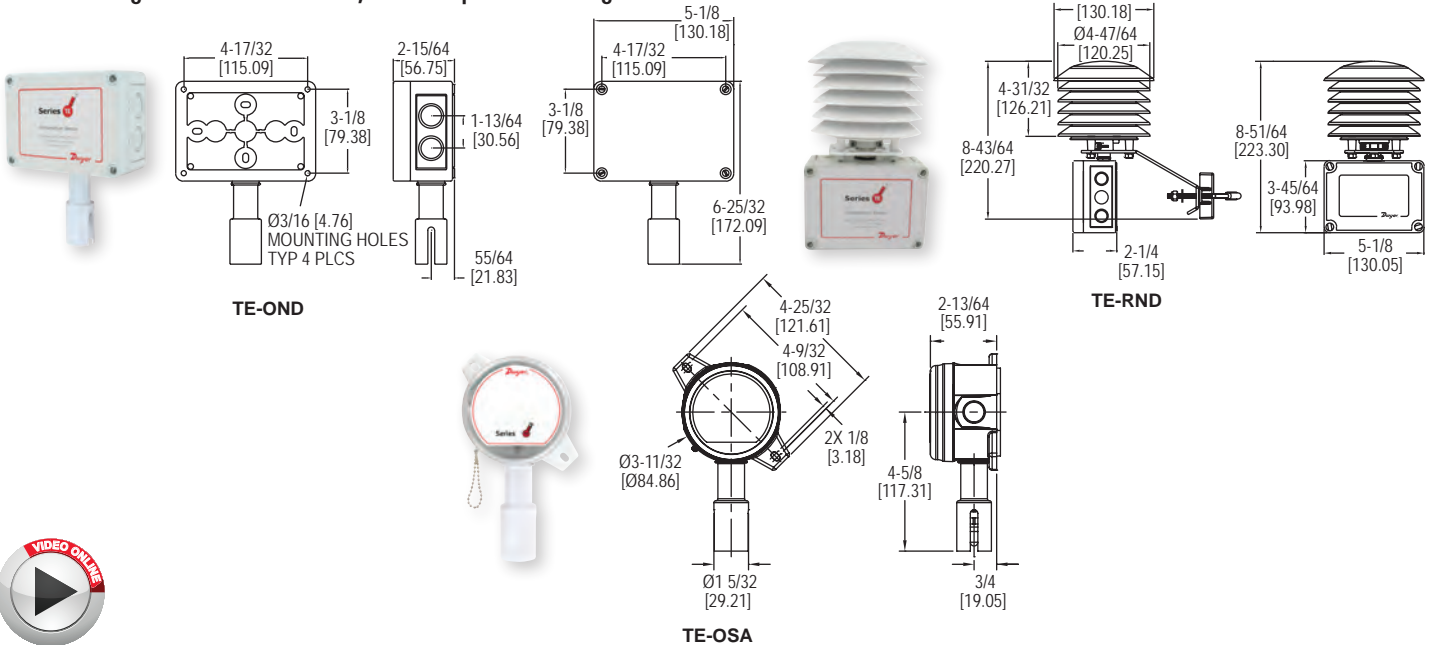

The Series TE-OND/TE-RND/TE-OSA Outdoor Temperature Sensors are offered different configurations to increase measurement accuracy by reducing radiated heat effects. For applications where the north side of the building is accessible, the TE-OND/TE-OSA can be used to protect against low levels of radiated heat.

**FEATURES/BENEFITS**

- Weatherproof for outdoor installation
- Radiation shield available to eliminate heating effects following installation in direct sunlight
- Terminal connector eliminates need for wire nuts

**APPLICATIONS**

- Building automation
- Outdoor temperature reference

MODEL CHART	
Model	Sensor Type
TE-OND-A	10k Ω type III thermistor
TE-OND-B	10k Ω type II thermistor
TE-OND-C	3k Ω thermistor
TE-OND-D	PT100 Ω RTD
TE-OND-E	PT1000 Ω RTD
TE-OND-F	20k Ω thermistor
TE-OND-Q	10k Ω type III thermistor with 11k Ω shunt
TE-RND-A	10k Ω type III thermistor
TE-RND-B	10k Ω type II thermistor
TE-RND-C	3k Ω thermistor
TE-RND-D	PT100 Ω RTD
TE-RND-E	PT1000 Ω RTD
TE-RND-F	20k Ω thermistor
TE-RND-Q	10k Ω type III thermistor with 11k Ω shunt
TE-OSA-A	10k Ω type III thermistor
TE-OSA-B	10k Ω type II thermistor
TE-OSA-C	3k Ω thermistor
TE-OSA-D	PT100 Ω RTD
TE-OSA-E	PT1000 Ω RTD
TE-OSA-F	20k Ω thermistor
TE-OSA-Q	10k Ω type III thermistor with 11k Ω shunt

**SPECIFICATIONS**

**Accuracy:** Thermistor temperature sensor: ±0.22°C @ 25°C (±0.4°F @ 77°F); RTD temperature sensor: DIN class A: ±0.15°C @ 0°C (±0.28°F @ 32°F).  
**Temperature Limits:** Operating: -40 to 302°F (-40 to 150°C).  
**Sensor Curves:** See Resistance vs. Temperature Table.  
**Housing Material:** Polycarbonate.  
**Enclosure Rating:** TE-OND/TE-RND: NEMA 4X (IP65); TE-OSA: NEMA 3R (IP54).  
**Weight:** 0.65 lb (295 g).

**RESISTANCE VS TEMPERATURE TABLE**

**Temperature Resistance Curves (Ω)**

°C	°F	A - 10k Ω type III thermistor	B - 10k Ω type II thermistor	C - 3k Ω thermistor	D - PT100 Ω RTD	E - PT1000 Ω RTD	F - 20k Ω thermistor	Q - 10k Ω type III thermistor with 11k Ω shunt
		Green/Green	Red/Green	Black/Black	Yellow/Yellow	Red/Red	Green/Blue	Red/White
-55	-67.0	607800.00	963849.00	289154.70	78.32	783.2	2394000.00	10804
-50	-58.0	441200.00	670166.00	201049.80	80.31	803.1	1646200.00	10732
-45	-49.0	323600.00	471985.00	141595.50	82.29	822.9	1145850.00	10638
-40	-40.0	239700.00	336479.00	100943.70	84.27	842.7	806800.00	10517
-35	-31.0	179200.00	242681.00	72804.30	86.25	862.5	574400.00	10364
-30	-22.0	135200.00	176974.00	53092.20	88.22	882.2	413400.00	10172
-25	-13.0	102900.00	130421.00	39126.30	90.19	901.9	300400.00	9938
-20	-4.0	78910.00	97081.00	29124.30	92.16	921.6	220600.00	9654
-15	5.0	61020.00	72957.00	21887.10	94.12	941.2	163500.00	9320
-10	14.0	47540.00	55329.00	16598.70	96.09	960.9	122280.00	8933
-5	23.0	37310.00	42327.00	12698.10	98.04	980.4	92240.00	8495
0	32.0	29490.00	32650.00	9795.00	100.00	1000.0	70160.00	8012
5	41.0	23460.00	25392.00	7617.60	101.95	1019.5	53780.00	7489
10	50.0	18780.00	19901.00	5970.30	103.90	1039.0	41560.00	6937
15	59.0	15130.00	15712.00	4713.60	105.85	1058.5	32340.00	6369
20	68.0	12260.00	12493.00	3747.90	107.79	1077.9	25360.00	5798
25	77.0	10000.00	10000.00	3000.00	109.74	1097.4	20000.00	5238
30	86.0	8194.00	8057.00	2417.10	111.67	1116.7	15892.00	4696
35	95.0	6752.00	6531.00	1959.30	113.61	1136.1	12704.00	4184
40	104.0	5592.00	5326.00	1597.80	115.54	1155.4	10216.00	3707
45	113.0	4655.00	4368.00	1310.40	117.47	1174.7	8264.00	3271
50	122.0	3893.00	3602.00	1080.60	119.40	1194.0	6722.00	2875
55	131.0	3271.00	2986.00	895.80	121.32	1213.2	5498.00	2521
60	140.0	2760.00	2488.00	746.40	123.24	1232.4	4520.00	2206
65	149.0	2339.00	2083.00	624.90	125.16	1251.6	3734.00	1929
70	158.0	1990.00	1752.00	525.60	127.08	1270.8	3100.00	1685
75	167.0	1700.00	1480.00	444.00	128.99	1289.9	2586.00	1472
80	176.0	1458.00	1255.00	376.50	130.90	1309.0	2166.00	1287
85	185.0	1255.00	1070.00	321.00	132.80	1328.0	1822.60	1126
90	194.0	1084.00	915.50	274.65	134.71	1347.1	1540.00	986.8
95	203.0	939.30	786.60	235.98	136.61	1366.1	1306.40	865.4
100	212.0	816.80	678.60	203.58	138.51	1385.1	1112.60	760.3
105	221.0	712.60	587.60	176.28	140.40	1404.0	951.00	669.2
110	230.0	623.60	510.60	153.18	142.29	1422.9	815.80	590.1
115	239.0	547.30	445.30	133.59	144.18	1441.8	702.20	521.4
120	248.0	481.80	389.60	116.88	146.07	1460.7	606.40	461.6
125	257.0	425.30	341.90	102.57	147.95	1479.5	525.60	409.5
130	266.0	376.40	301.00	90.30	149.83	1498.3	N/A	363.9
135	275.0	334.00	265.80	79.74	151.71	1517.1	N/A	324.2
140	284.0	297.20	235.30	70.59	153.58	1535.8	N/A	289.4
145	293.0	265.10	208.90	62.67	155.46	1554.6	N/A	258.9
150	302.0	237.00	186.10	55.83	157.33	1573.3	N/A	232.0



# AVERAGING TEMPERATURE SENSOR

Available in 6', 12' and 24' Lengths

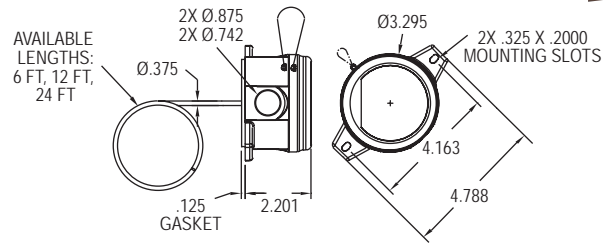

The Series TE-A Averaging Temperature Sensor features a long bendable aluminum capillary to measure the average temperature in large ducts and air handler units.

**FEATURES/BENEFITS**

- Easy to mount external tab housing
- 1/4 turn housing cover with chain
- Multiple conduit knockouts for easy installation positioning

**APPLICATIONS**

- Building automations
- Air handler unit monitoring
- Large air duct temperature monitoring

**SPECIFICATIONS**

**Accuracy:** Thermistor temperature sensor:  $\pm 0.22^{\circ}\text{C}$  @  $25^{\circ}\text{C}$  ( $\pm 0.4^{\circ}\text{F}$  @  $77^{\circ}\text{F}$ ).  
**Temperature Limits:** -40 to  $302^{\circ}\text{F}$  (-40 to  $150^{\circ}\text{C}$ ).  
**Capillary Lengths:** 6, 12 or 24' (depending on model).  
**Cable Length:** 4".  
**Sensor Curves:** See page reference 1 below.  
**Probe Material:** Bendable aluminum probe.  
**Housing Material:** Meets UL, 94 V-0 polycarbonate plastic.  
**Weight:** 14 oz (397 g).

**MODEL CHART**

Model	Sensor Type	Capillary Length	Model	Sensor Type	Capillary Length
TE-AAG-A0634-00	10k type III NTC thermistor	6'	TE-AAG-C0634-00	3k NTC thermistor	6'
TE-AAG-A1234-00	10k type III NTC thermistor	12'	TE-AAG-C1234-00	3k NTC thermistor	12'
TE-AAG-A2434-00	10k type III NTC thermistor	24'	TE-AAG-C2434-00	3k NTC thermistor	24'
TE-AAG-B0634-00	10k type II NTC thermistor	6'	TE-AAG-F0634-00	20k NTC thermistor	6'
TE-AAG-B1234-00	10k type II NTC thermistor	12'	TE-AAG-F1234-00	20k NTC thermistor	12'
TE-AAG-B2434-00	10k type II NTC thermistor	24'	TE-AAG-F2434-00	20k NTC thermistor	24'

**AVERAGING TEMPERATURE SENSOR CLIPS**

Model	Color	Sensor Diameter Size
CC1-N	Natural	3/8", 1/4", or 1/8"
CC1-GY	Grey	3/8", 1/4", or 1/8"

Note: Sold individually

1 Resistance vs. Temperature Table: See page 148 (Series TE-OND/RND/OSA)

**SERIES O-4**

# OUTSIDE AIR TEMPERATURE SENSOR

NEMA 4X, Removable Terminal Block

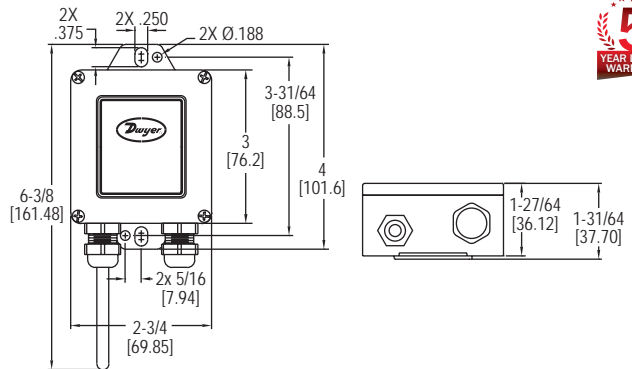

The Series O-4 Outside Air Temperature Sensor is great for monitoring ambient air temperatures in outdoor applications. The temperature sensors are mounted in a NEMA 4X enclosure with integral mounting tabs.

**FEATURES/BENEFITS**

- NEMA 4X weatherproof housing
- Surface or suspension mount

**APPLICATIONS**

- Agricultural house ventilation
- HVAC and building automation

**MODEL CHART**

Model	Sensor Type	Model	Sensor Type
O-4A	10k $\Omega$ type III thermistor	O-4D	Pt100 $\Omega$ RTD
O-4B	10k $\Omega$ type II thermistor	O-4E	Pt1000 $\Omega$ RTD
O-4C	3k $\Omega$ thermistor	O-4F	20k $\Omega$ thermistor

**SPECIFICATIONS**

**Accuracy:** Thermistor temperature sensor:  $\pm 0.22^{\circ}\text{C}$  @  $25^{\circ}\text{C}$  ( $\pm 0.4^{\circ}\text{F}$  @  $77^{\circ}\text{F}$ ); RTD temperature sensor: DIN class B:  $\pm 0.3^{\circ}\text{C}$  @  $0^{\circ}\text{C}$  ( $\pm 0.54^{\circ}\text{F}$  @  $32^{\circ}\text{F}$ ).  
**Operating Temperature:** -40 to  $250^{\circ}\text{F}$ .  
**Probe Diameter:** 0.235" (5.97 mm).  
**Probe Length:** 3.5".  
**Probe Material:** 304 SS.  
**Mounting:** Suspension or surface.  
**Enclosure Rating:** NEMA 4X (IP66).  
**Weight:** 3 oz (85 g).  
**Agency Approvals:** Meets the technical requirements of EU Directive 2011/65/EU (RoHS II).

**Dwyer**  
SERIES TE-SNW

# WEATHER RESISTANT SURFACE TEMPERATURE SENSOR

Strap On Design, Twist Off Cover, 2 to 6" Pipe Sizes

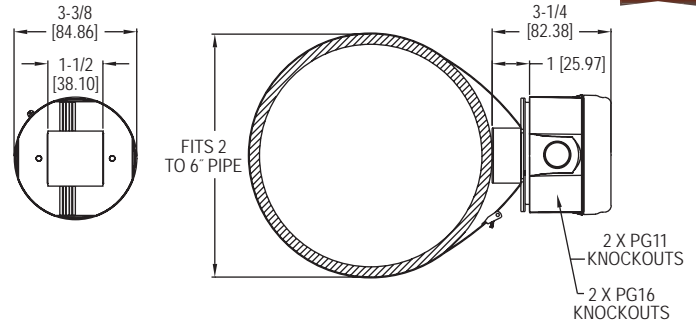

The **Series TE-SNW Weather Resistant Surface Temperature Sensor** non-intrusively measures the process temperature in hot and cold water loops in buildings. In order to work with most common building controllers, the output of the sensor can be chosen from 6 different RTD and Thermistor curves.

**FEATURES/BENEFITS**

- Easy to mount external tab housing
- 1/4 turn housing cover with chain
- Multiple conduit knockouts for easy installation positioning
- Non-intrusive temperature measurement of 2 to 6" pipes

**APPLICATIONS**

- Heating or cooling loop line temperature monitoring
- HVAC systems

**SPECIFICATIONS**

**Accuracy:** Thermistor temperature sensor:  $\pm 0.22^{\circ}\text{C}$  @  $25^{\circ}\text{C}$  ( $\pm 0.4^{\circ}\text{F}$  @  $77^{\circ}\text{F}$ ); RTD temperature sensor: DIN Class A  $\pm 0.15^{\circ}\text{C}$  @  $0^{\circ}\text{C}$  ( $\pm 0.28^{\circ}\text{F}$  @  $32^{\circ}\text{F}$ ).  
**Temperature Limits:** Operating:  $-32$  to  $240^{\circ}\text{F}$  ( $-35.5$  to  $115.5^{\circ}\text{C}$ ).  
**Sensor Curves:** See page reference 1 below.  
**Housing Material:** Meets UL 94 V-0 polycarbonate plastic, NEMA 3R.  
**Weight:** 7 oz (198 g).

**MODEL CHART**

Model	Sensor Type
TE-SNW-A	10k $\Omega$ type III thermistor
TE-SNW-B	10k $\Omega$ type II thermistor
TE-SNW-C	3k $\Omega$ thermistor
TE-SNW-D	Pt100 $\Omega$ RTD
TE-SNW-E	Pt1000 $\Omega$ RTD
TE-SNW-F	20k $\Omega$ thermistor

1 Resistance vs. Temperature Table: See page 148 (Series TE-OND/RND/OSA)

**SERIES S2-1**

# SURFACE MOUNT TEMPERATURE SENSOR

RTD and Thermistor, 304 SS Probe

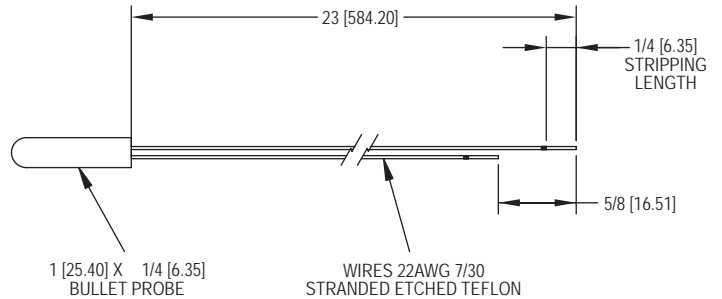

**S2-1X no housing**

The **Series S2-1 Surface Mount Temperature Sensor** provides a cost effective and reliable solution for surface contact temperature measurement of conditioned water pipes, low pressure steam or refrigerant lines.

**FEATURES/BENEFITS**

- Low profile sensor can be taped or strapped to the outside of a pipe
- Ideal for applications where immersion wells are not feasible

**APPLICATIONS**

- Heating or cooling loop line temperature monitoring
- HVAC systems

**SPECIFICATIONS**

**Accuracy:** Platinum RTD:  $\pm 0.1\%$  @  $32^{\circ}\text{F}$  ( $0^{\circ}\text{C}$ ), alpha 385 per DIN 43760; Thermistor:  $\pm 0.5^{\circ}\text{C}$  interchangeable @  $77^{\circ}\text{F}$  ( $25^{\circ}\text{C}$ ).  
**Operating Temperature:**  $-40$  to  $250^{\circ}\text{F}$  ( $-40$  to  $120^{\circ}\text{C}$ ).  
**Probe Diameter:**  $1/4"$  (6.3 mm).  
**Probe Length:**  $1"$  (25 mm).  
**Probe Material:** 304 SS.

**MODEL CHART**

Model	Sensor Type
S2-1A	10k Type III thermistor
S2-1B	10k Type II thermistor
S2-1C	3k thermistor
S2-1D	Pt100 RTD
S2-1E	Pt1000 RTD
S2-1F	20k thermistor

Teflon® is a registered trademark of E.I. Dupont De Nemours and Company

**SELECTION GUIDE**  
pages 152-155

**TYPICAL APPLICATIONS**  
pages 156-157

**HVAC Mobile Application**  
page 156

**HVAC MEASUREMENT GUIDE**  
pages 158-163

**HVAC Balancing Instruments**  
pages 164-166, 168, 174

**TraverseIT™ Software Application**  
page 167

**Thermo-Hygrometers**  
page 169

**Thermo-Anemometers**  
pages 170-171, 192

**Manometers, Portable**  
pages 172-173, 175-176, 178-184

**Manometers, Air Velocity**  
pages 177, 185

**Pitot Tubes**  
pages 167, 186-188

**Air Flow Grids**  
page 189

**Vane Anemometer**  
page 190

**Wind Meters**  
page 190-191

**Thermocouple Thermometers**  
page 193

**Combustion Gas Analyzers/Kits**  
pages 194

**Tachometer**  
pages 195

**Signal Generators/ Multimeters**  
page 196

**Calibration Pumps**  
pages 197-199

**Chart Recorders**  
page 200

**Data Loggers, Temperature**  
page 200

**Data Loggers, Single Pressure**  
page 201

**Data Loggers, Indicating**  
page 202

**Data Loggers, USB**  
page 203

**Data Loggers, Wireless**  
page 204

## FEATURED PRODUCTS

### SMART AIR HOOD® BALANCING INSTRUMENT SERIES SAH | page 164



- Patent pending Quad Flow Design Technology enables accurate readings
- Predictive Balancing that guides setting the optimal flow set point for each sequential terminal
- The ergonomic design is much lighter and easier to use than traditional air flow hoods

### 100 MM VANE THERMO-ANEMOMETER TEST INSTRUMENT SERIES 473B | page 170



- Included 100 mm vane probe is able to measure air velocity, volumetric air flow, temperature, and humidity
- Compatible with Dwyer AP1 thermo-anemometer and RP1 thermo-hygrometer wired probes (sold separately)

DIGITAL  
Manometers**AQ1A-WDPM**

- page 165

**477AV** - page 175**475** - page 176**476A** - page 178**478A** - page 178

<b>SERIES</b>	<b>AQ1A-WDPM</b> - page 165	<b>477AV</b> - page 175	<b>475</b> - page 176	<b>476A</b> - page 178	<b>478A</b> - page 178
<b>Range</b>	2 to 350 in w.c. (0.5 to 87 kPa)	1 in w.c. to 150 psi (.25 kPa to 10.34 bar)	1 in w.c. to 150 psi (.25 kPa to 10.34 bar)	±20 in w.c. (±5 kPa)	±4 in w.c.; ±60 in w.c. (±1 kPa; ±15 kPa)
<b>Service</b>	Non-corrosive dry gases	Air and compatible gases	Air and compatible combustible gases	Air and compatible gases	Air and compatible gases
<b>Wetted Materials</b>	Consult factory	Consult factory	Consult factory	Consult factory	Consult factory
<b>Accuracy</b>	±0.5% FS	±0.5% FS	±0.5% FS	±1.0% FS	±0.5% FS
<b>Pressure Limits</b>	10 psi (2 to 10 in w.c.); 20 psi (20 to 30 in w.c.); 15 psi (100 in w.c.); 45 psi (200 to 350 in w.c.)	5 psig (1 to 10 in w.c.); 10 psig (20 to 40 in w.c.); 30 psig (200 in w.c. to 10 psi); 60 psig (20 to 30 psi); 150 psig (100 psi); 200 psig (150 psi)	5 psig (1 to 10 in w.c.); 10 psig (20 to 40 in w.c.); 30 psig (200 in w.c. to 10 psi); 60 psig (20 to 30 psi); 150 psig (100 psi); 200 psig (150 psi)	5 psig (.34 bar)	5 psig (.34 bar)
<b>Temperature Limits</b>	14 to 140°F (-10 to 60°C)	0 to 140°F (-17.8 to 60°C)	0 to 140°F (-17.8 to 60°C)	0 to 140°F (-17.8 to 60°C)	0 to 140°F (-17.8 to 60°C)
<b>Comp. Temp. Limits</b>	32 to 140°F (0 to 60°C)	32 to 104°F (0 to 40°C)	32 to 104°F (0 to 40°C)	32 to 104°F (0 to 40°C)	32 to 104°F (0 to 40°C)
<b>Housing Protection</b>	Handheld: IP68	Rugged aluminum housing	Rugged aluminum housing	Rugged aluminum housing	Rugged aluminum housing
<b>Display</b>	4.3" QHD Gorilla glass, 960 x 540	4-digit backlit LCD	4-digit LCD	4-digit LCD	4-digit LCD
<b>Memory</b>	RAM 1 GB & ROM 4 GB	40 readings	N/A	N/A	N/A
<b>Process Connection</b>	(2) Barbed connections for use with 1/8" or 3/16" ID tubing	(2) Barbed connections for use with 1/8" or 3/16" ID tubing (Compression fittings for -7, -8 ranges)	(2) Barbed connections for use with 1/8" or 3/16" ID tubing (Compression fittings for -7, -8 ranges)	Barbed connection for use with 3/16" or 1/4" ID tubing	(2) Barbed connection for use with 3/16" or 1/4" ID tubing
<b>Approvals</b>	CE, FCC	CE	CE, FM	CE	CE

These Selection Guides are for quick comparison of similar products. Please refer to the catalog page number referenced for complete product information and specifications.



# DIGITAL Manometers

				
<b>SERIES</b>	<b>477B</b> - page 179	<b>490A</b> - page 180	<b>HM35</b> - page 181	<b>HM28</b> - page 181
<b>Range</b>	20 in w.c. to 100 psi (4.982 to 689.5 kPa)	15 to 200 psi (1 to 13.8 bar)	10 in w.c. to 1305 psi (2.5 to 9000 kPa)	10 in w.c. to 245 psi (2.5 to 1700 kPa)
<b>Service</b>	Air and compatible gases	Compatible gases and liquids	Air and compatible gases	Air and compatible gases
<b>Wetted Materials</b>	Consult factory	316L SS; With 3-way valve: Buna-N, silicone grease, PTFE, brass 360, copper, reinforced acetal copolymer	18/8 SS	18/8 SS
<b>Accuracy</b>	±0.1% FS	±0.5% FS	(±0.2% FS, ±0.1% FS, or ±0.05% FS) ±1 digit	(±0.2% FS, ±0.1% FS, or ±0.05% FS) ±1 digit
<b>Pressure Limits</b>	3 psig (20 to 40 in w.c.); 15 psig (200 in w.c.); 30 psig (10 psi); 60 psig (30 psi); 100 psig (50 psi); 200 psig (100 psi)	30 psig (15 psi); 60 psig (30 psi); 100 psig (50 psi); 200 psig (100 psi); 400 psig (200 psi); 1000 psig (500 psi)	N/A	N/A
<b>Temperature Limits</b>	0 to 140°F (-17.8 to 60°C)	32 to 140°F (0 to 60°C)	32 to 122°F (0 to 50°C)	23 to 122°F (-5 to 50°C)
<b>Comp. Temp. Limits</b>	N/A	N/A	N/A	N/A
<b>Housing Protection</b>	Rugged aluminum housing	Rugged aluminum housing	IP54 (NEMA 3)	IP54 (NEMA 3)
<b>Display</b>	4-digit backlit LCD	4-digit backlit LCD	Graphical backlit LCD, 128 x 64 points	2 line, 16 character, dot matrix LCD, with switchable display sizes
<b>Memory</b>	40 readings	Up to 40 readings	10,742 readings	10,742 readings
<b>Process Connection</b>	(2) Barbed connections for use with 1/8" or 3/16" ID tubing (Compression fittings for -6, -7 ranges)	(2) 1/8" female NPT	Hose 4/6 mm or 1/8" NPT	Hose 4/6 mm or 1/8" NPT
<b>Approvals</b>	CE	CE	N/A	N/A

Dwyer

# THERMO

## Anemometers



SERIES	AQTIA-AP2 - page 165	AQTIA-VP2 - page 165	473B - page 170
Air Velocity Range	0 to 6000 FPM (0 to 30 m/s)	40 to 5000 FPM (0.25 to 25 m/s)	40 to 5000 FPM (0.2 to 25 m/s)
Air Velocity Accuracy	±3% FS	±1.5% of reading ±20 FPM	±1.5% of reading ±20 FPM
Temperature Range	-40 to 212°F (-40 to 100°C)	-22 to 140°F (-30 to 60°C)	-20 to 212°F (-29 to 100°C)
Temperature Accuracy	±0.5°F (±0.28°C)	±0.54°F (±0.3°C)	±0.54°F (±0.3°C)
Humidity Range	N/A	0 to 100% RH	0 to 100% RH
Humidity Accuracy	N/A	±2% RH	±2% RH
Air Volume Range	999,999 in selected flow units	999,999 in selected flow units	19,999 in selected flow units
Wet Bulb Range	N/A	N/A	N/A
Meter Temperature Range	Operating: -4 to 140°F (-20 to 60°C) Storage: -40 to 176°F (-40 to 80°C)	Operating: -4 to 140°F (-20 to 60°C) Storage: -40 to 176°F (-40 to 80°C)	Process: -20 to 212°F (-29 to 100°C) Ambient: 5 to 125°F (-15 to 51°C)
Meter Humidity Limits	5 to 95% RH	5 to 95% RH	N/A
Display	4.3" QHD Gorilla glass, 960 x 540	4.3" QHD Gorilla glass, 960 x 540	4.5-digit backlit LCD
Approvals	CE, FCC	CE, FCC	N/A

# CALIBRATION

## Pumps



SERIES	HP - page 197	CHP - page 197	A-396A - page 197	PCHP - page 198
Output Range	-27" Hg to 45 psig (-0.91 to 3 bar)	-28.8" Hg to 100 psi (-0.975 to 3.4 bar)	<1 in w.c. to 72 psig (5 bar)	-28" Hg to 600 psi (-0.945 to 40 bar)
Process Connection	1/4" female NPT	1/8" female NPT	Barbed fitting or 1/8" female NPT	1/4" female NPT/BSPT
Gage Connection	1/4" female NPT	1/8" female NPT	N/A	1/8" female NPT/BSPT
Materials	N/A	Acetal plastic and anodized aluminum	N/A	SS fittings, anodized aluminum housing, plastic/rubber handles, and nitrile O-rings

These Selection Guides are for quick comparison of similar products. Please refer to the catalog page number referenced for complete product information and specifications.

# THERMO Anemometers



SERIES	471B - page 171	VT-300 - page 192
Air Velocity Range	0 to 6000 FPM (0 to 30 m/s)	98.4 to 3937 FPM (0.5 to 20 m/s)
Air Velocity Accuracy	±3% FS	±3% of reading ± 0.2 m/s
Temperature Range	-40 to 212°F (-40 to 100°C)	-4 to 140°F (-20 to 60°C)
Temperature Accuracy	±0.5°F (±0.28°C)	±1°F (±0.6°C)
Humidity Range	N/A	0.1 to 99.9% RH
Humidity Accuracy	N/A	±3% RH
Air Volume Range	19,999 in selected flow units	99,999 (CFM or m3/s)
Wet Bulb Range	N/A	-7.6 to 158°F (-22 to 70°C)
Meter Temperature Range	Process Air Velocity: -20 to 212°F (-29 to 100°C); Process Temperature: -40 to 212°F (-40 to 100°C); Ambient: 5 to 125°F (-15 to 51°C)	32 to 122°F (0 to 50°C)
Meter Humidity Limits	N/A	<80% RH
Display	4.5-digit backlit LCD	1 x 1.8" (26 x 45 mm) graphical LCD
Approvals	CE	N/A

# CALIBRATION Pumps



SERIES	HCHP - page 198	LPCP - page 199	BCHP - page 199
Output Range	0 to 10,000 psi (0 to 700 bar)	-5.8 psi to 5.8 psi (-0.4 to 0.4 bar)	-28" Hg to 870 psi (-0.95 to 60 bar)
Process Connection	1/4" female NPT/BSPT	M20x1.5 or 1/4" female NPT	1/4" female BSPT (NPT available)
Gage Connection	1/4" female NPT/BSPT	M20x1.5 or 1/4" female NPT	1/2" female BSPT
Materials	SS, polyurethane, anodized hard-coat aluminum, PTFE, and nitrile	Ram/adapters: 316 SS, Body: Steel/aluminum; Seals: Buna-N	Anodized aluminum, brass, and ABS



**Current/voltage signal generator used to calibrate panel meters.**

The Model CSG Digital Signal Generator is perfect for generating or simulating input signals to panel meters and process controllers. The signal generator is capable of sourcing up to 10 VDC or 20 mA in 1 VDC or 1 mA steps. The backlit digital display allows users to quickly compare the reading on the Model CSG to that of the panel meter or process controller. The signal from the Model CSG can be used to set up the upper and lower limits of the process range. It can also be used to ensure that set point and alarm functions are working properly on the panel meter or process controller.



**Combustion analyzer maximize boiler efficiency while monitoring harmful products of combustion.**

There are several critical factors in attaining efficient combustion for boilers and other combustors. Monitoring the temperature of combustion and minimizing the amount of excess air in the system are undoubtedly essential steps. A Dwyer® 1207-NOx Flue Gas Analyzer can break down the products of combustion, giving an accurate volumetric composition of harmful NOx compounds, O<sub>2</sub>, CO<sub>2</sub>, and CO. Additionally, the 1207-NOx will monitor differential temperature, excess air and poison index. Results can be easily viewed on screen or uploaded to a PC via the user-friendly software.

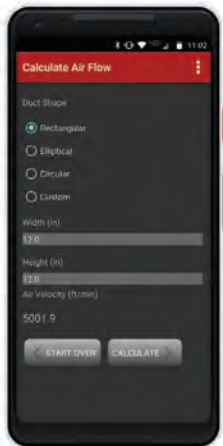

**FREE DOWNLOAD!**  
Download our Air Velocity and Flow Calculator app today.



**HVAC mobile application.**

For those customers in the HVAC or BAS industry, Dwyer offers the Air Velocity and Flow Calculator App available on the Google Play® store. One can easily convert velocity pressure to air velocity or air velocity to air volume. Converting velocity pressure to air volume is advantageous for effortlessly changing the pressure on your Magnehelic® Differential Pressure Gage or manometer to velocity. Moreover, this Calculator also includes air density factors from humidity levels. By utilizing the air velocity to air volume functionality, one can simplistically convert the air velocity to air flow rates from duct dimensions, with just the tap of a button.

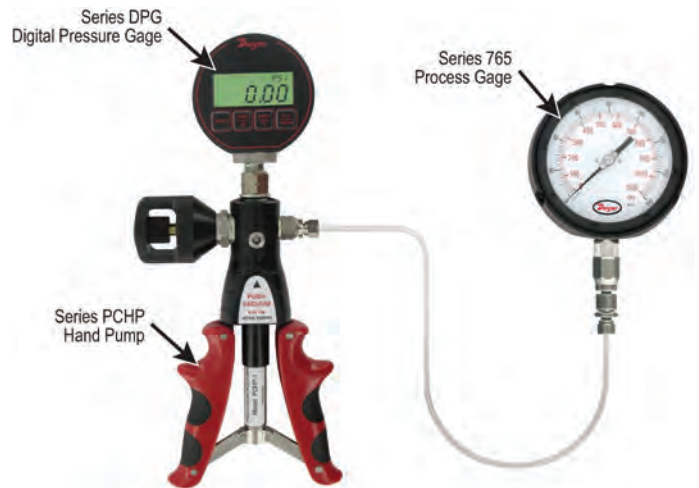

**Field calibrate and certify pressure gages.**

Using the Series PHP-1 with a Series DPG-100, a technician can calibrate or certify process pressure gages up to 1% accurate. The Model PCHP-1 hand pump can easily supply pressures up to 600 PSI by squeezing the handle and adjusting the volume control valve. The pump has two connections to be connected with a test gage, such as the Dwyer® Series DPG-100, and a process gage, such as the Dwyer® Series 765.





### Digital Manometers used to check gas pressure to a heating burner.

Checking the gas pressure to a heating unit on the burner side of the regulator is a standard installation and service routine. The Dwyer® Series 475 Handheld Digital Manometer is a low-cost, durable device that is easily transportable in a pocket or briefcase. Units are highly accurate with 0.5% full-scale accuracy. Some servicemen prefer our portable Dwyer® Magnehelic® Differential Pressure Gage with dial type scale for field use.

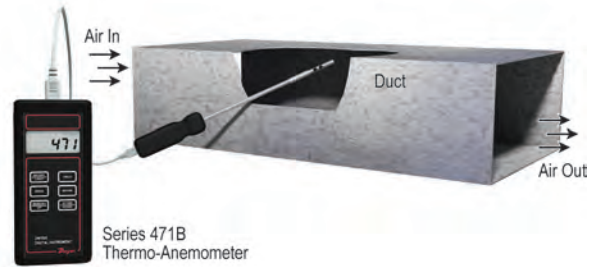

### Determine air velocity and temperature levels in ducts or air supply grills.

The Dwyer® Series 471B Digital Thermo-Anemometer is the ideal portable product for determining air velocity and temperature levels in ducts or air supply grills. With a push of a button, FPM and Fahrenheit readings are converted to MPS and Celsius. Readings may be stored and retrieved which allows the user greater efficiency with HVAC balancing at various locations in a building.

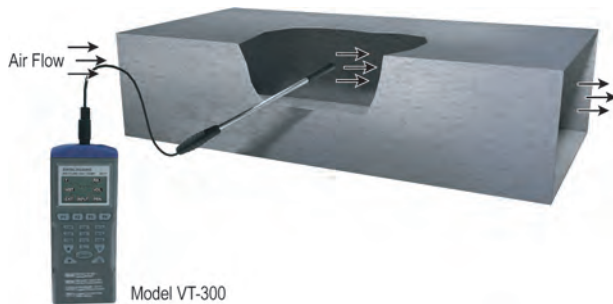

### Handheld anemometer enables measuring duct flow measurements.

Handheld anemometers are an excellent, portable tool for performing tests on HVAC system performance; however, large rotating vanes can prevent easy access to ducts. Dwyer introduces the VT-300 Mini-Vane Thermo-Anemometer to eliminate this problem. Additionally, simple keypad programming enables the user to view volumetric flow rates in CFM or CMM.



### Quickly measure humidity and temperature levels in ambient air.

The Dwyer® Model 485B-1 Thermo-Hygrometer is a simple, portable device for quickly measuring humidity and temperature levels in ambient air. The dew point and wet-bulb temperature readings are derived from relative humidity and temperature measurements. The Model 485B-1 is often used in agricultural applications where proper humidity and temperature levels are critical in plant or animal well being.

# AIR VELOCITY MEASUREMENT

## INTRODUCTION

In air conditioning, heating and ventilating work, it is helpful to understand the techniques used to determine air velocity. In this field, air velocity (distance traveled per unit of time) is usually expressed in feet per minute (FPM). By multiplying air velocity by the cross section area of a duct, you can determine the air volume flowing past a point in the duct per unit of time. Volume flow is usually measured in cubic feet per minute (CFM).

Velocity or volume measurements can often be used with engineering handbook or design information to reveal proper or improper performance of an airflow system. The same principles used to determine velocity are also valuable in working with pneumatic conveying, flue gas flow and process gas systems. However, in these fields the common units of velocity and volume are sometimes different from those used in air conditioning work.

To move air, fans or blowers are usually used. They work by imparting motion and pressure to the air with either a screw propeller or paddle wheel action. When force or pressure from the fan blades causes the air to move, the moving air acquires a force or pressure component in its direction of motion due to its weight and inertia. Because of this, a flag or streamer will stand out in the air stream. This force is called velocity pressure. It is measured in inches of water column (w.c.) or water gage (w.g.). In operating duct systems, a second pressure is always present. It is independent of air velocity or movement. Known as static pressure, it acts equally in all directions. In air conditioning work, this pressure is also measured in inches w.c.

In pressure or supply systems, static pressure will be positive on the discharge side of the fan. In exhaust systems, a negative static pressure will exist on the inlet side of the fan. When a fan is installed midway between the inlet and discharge of a duct system, it is normal to have a negative static pressure at the fan inlet and positive static pressure at its discharge.

Total pressure is the combination of static and velocity pressures, and is expressed in the same units. It is an important and useful concept to use because it is easy to determine and, although velocity pressure is not easy to measure directly, it can be determined easily by subtracting static pressure from total pressure. This subtraction need not be done mathematically. It can be done automatically with the instrument hook-up.

## SENSING STATIC PRESSURE

For most industrial and scientific applications, the only air measurements needed are those of static pressure, total pressure and temperature. With these, air velocity and volume can be quickly calculated.

To sense static pressure, six types of devices are commonly used. These are connected with tubing to a pressure indicating instrument. Fig. 1-A shows a simple thru-wall static pressure tap. This is a sharp, burr-free opening through a duct wall provided with a tubing connection of some sort on the outside. The axis of the tap or opening must be perpendicular to the direction of flow. This type of tap or sensor is used where air flow is relatively slow, smooth and without turbulence. If turbulence exists, impingement, aspiration or unequal distribution of moving air at the opening can reduce the accuracy of readings significantly.

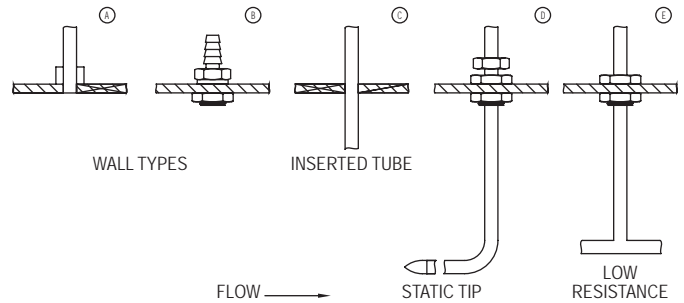

Figure 1 - Types of static pressure devices

Fig. 1-B shows the Dwyer® No. A-308 Static Pressure Fitting. Designed for simplified installation, it is easy to install, inexpensive, and provides accurate static pressure sensing in smooth air at velocities up to 1500 FPM.

Fig. 1-C shows a simple tube through the wall. Limitations of this type are similar to wall type Fig. 1-A.

Fig. 1-D shows a static pressure tip which is ideal for applications such as sensing the static pressure drop across industrial air filters and refrigerant coils. Here the probability of air turbulence requires that the pressure sensing openings be located away from the duct walls to minimize impingement and aspiration and thus ensure accurate readings. For a permanent installation of this type, the Dwyer® No. A-301 or A-302 Static Pressure Tip is used. It senses static pressure through radially-drilled holes near the tip and can be used in air flow velocities up to 12,000 FPM.

Fig. 1-E shows a Dwyer® No. A-305 low resistance Static Pressure Tip. It is designed for use in dust-laden air and for rapid response applications. It is recommended where a very low actuation pressure is required for a pressure switch or indicating gage — or where response time is critical.

## MEASURING TOTAL PRESSURE AND VELOCITY PRESSURE

In sensing static pressure we make every effort to eliminate the effect of air movement. To determine velocity pressure, it is necessary to determine these effects fully and accurately. This is usually done with an impact tube which faces directly into the air stream. This type of sensor is frequently called a “total pressure pick-up” since it receives the effects of both static pressure and velocity pressure.

# AIR VELOCITY MEASUREMENT

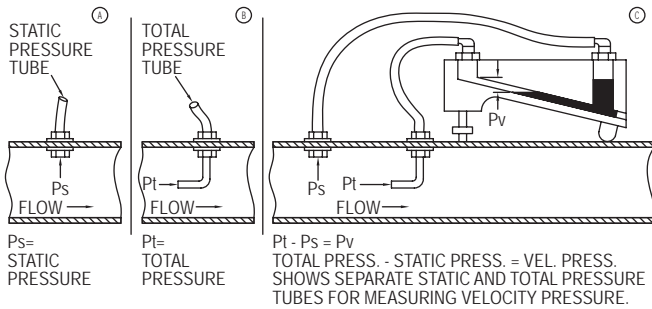

Figure 2 - Types of pressure measurements

In Figure 2, note that separate static connections (A) and total pressure connections (B) can be connected simultaneously across a manometer (C). Since the static pressure is applied to both sides of the manometer, its effect is cancelled out and the manometer indicates only the velocity pressure.

To translate velocity pressure into actual velocity requires either mathematical calculation, reference to charts or curves, or prior calibration of the manometer to directly show velocity. In practice this type of measurement is usually made with a Pitot tube which incorporates both static and total pressure sensors in a single unit.

Essentially, a Pitot tube consists of an impact tube (which receives total pressure input) fastened concentrically inside a second tube of slightly larger diameter which receives static pressure input from radial sensing holes around the tip. The air space between the inner and outer tubes permits transfer of pressure from the sensing holes to the static pressure connection at the opposite end of the Pitot tube and then, through connecting tubing, to the low or negative pressure side of a manometer. When the total pressure tube is connected to the high pressure side of the manometer, velocity pressure is indicated directly. See Figure 3.

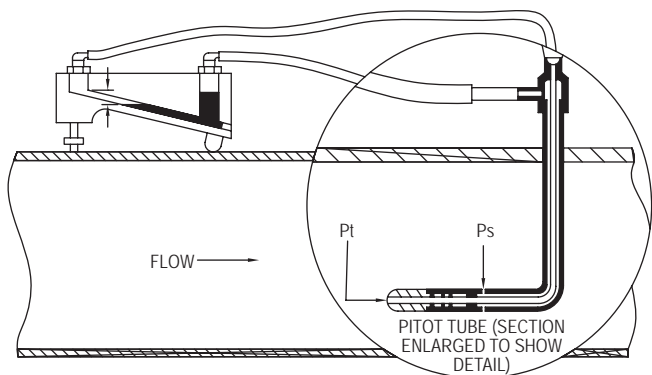

Figure 3 - Pitot tube senses total and static pressures. Manometer measures velocity pressure – (difference between total and static pressures).

Since the Pitot tube is a primary standard device used to calibrate all other air velocity measuring devices, it is important that great care be taken in its design and fabrication. In modern Pitot tubes, proper nose or tip design — along with sufficient distance between nose, static pressure taps and stem — will minimize turbulence and interference. This allows use without correction or calibration factors. All Dwyer® Pitot tubes are built to AMCA and ASHRAE standards and have unity calibration factors to assure accuracy.

To ensure accurate velocity pressure readings, the Pitot tube tip must be pointed directly into (parallel with) the air stream. As the Pitot tube tip is parallel with the static pressure outlet tube, the latter can be used as a pointer to align the tip properly. When the Pitot tube is correctly aligned, the pressure indication will be maximum.

Because accurate readings cannot be taken in a turbulent air stream, the Pitot tube should be inserted at least 8-1/2 duct diameters downstream from elbows, bends or other obstructions which cause turbulence. To ensure the most precise measurements, straightening vanes should be located 5 duct diameters upstream from the Pitot tube.

## HOW TO TAKE TRAVERSE READINGS

In practical situations, the velocity of the air stream is not uniform across the cross section of a duct. Friction slows the air moving close to the walls, so the velocity is greater in the center of the duct.

To obtain the average total velocity in ducts of 4" diameter or larger, a series of velocity pressure readings must be taken at points of equal area. A formal pattern of sensing points across the duct cross section is recommended. These are known as traverse readings. Figure 4 shows recommended Pitot tube locations for traversing round and rectangular ducts.

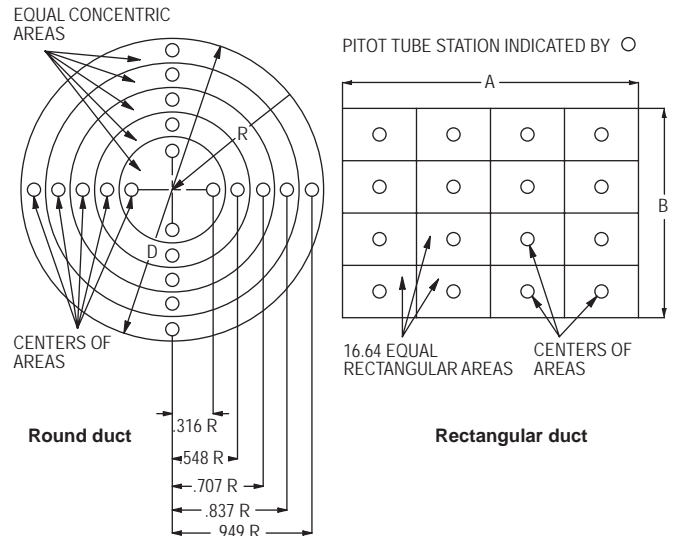

Figure 4 - Traverse on round and rectangular duct areas

In round ducts, velocity pressure readings should be taken at centers of equal concentric areas. At least 20 readings should be taken along two diameters. In rectangular ducts, a minimum of 16 and a maximum of 64 readings are taken at centers of equal rectangular areas. Actual velocities for each area are calculated from individual velocity pressure readings. This allows the readings and velocities to be inspected for errors or inconsistencies. The velocities are then averaged.

By taking Pitot tube readings with extreme care, air velocity can be determined within an accuracy of ±2%. For maximum accuracy, the following precautions should be observed:

1. Duct diameter should be at least 30 times dia. of Pitot tube.
2. Locate the Pitot tube in a duct section providing 8-1/2 or more duct diameters upstream and 1-1/2 or more diameters downstream of Pitot tube free of elbows, size changes or obstructions.
3. Provide an egg-crate type of flow straightener 5 duct diameters upstream of Pitot tube.
4. Make a complete, accurate traverse.

In small ducts or where traverse operations are otherwise impossible, an accuracy of ±5% can frequently be achieved by placing Pitot tube in center of duct. Determine velocity from the reading, then multiply by 0.9 for an approximate average.

# AIR VELOCITY MEASUREMENT



## CALCULATING AIR VELOCITY FROM VELOCITY PRESSURE

Manometers for use with a Pitot tube are offered in a choice of two scale types. Some are made specifically for air velocity measurement and are calibrated directly in feet per minute. They are correct for standard air conditions: i.e. air density of .075 lb per ft<sup>3</sup> corresponds to dry air at 70°F, barometric pressure of 29.92 inches Hg. To correct the velocity reading for other than standard air conditions, the actual air density must be known. It may be calculated if relative humidity, temperature and barometric pressure are known.

Most manometer scales are calibrated in inches of water. Using readings from such an instrument, the air velocity may be calculated using the basic formula:

$$V = 1096.7 \sqrt{\frac{h_v}{d}} \left\{ = 4004.4 \sqrt{h_v} \text{ for } .075 \text{ lb/ft}^3 \text{ dry air @ } 70^\circ\text{F, } 29.92 \text{ in. Hg Baro.} \right\}$$

Where: V = Velocity in feet per minute.  
 $h_v$  = Velocity pressure in inches of water.  
 d = Density of air in pounds per cubic foot.

To determine dry air density, use the formula:

$$d = 1.325 \frac{P_B}{T}$$

Where: d = Air density in pounds per cubic foot.

$$P_B = \left\{ \begin{array}{l} \text{Barometric (or absolute) static pressure in inches of mercury.} \\ T = \text{Absolute temperature (indicated temperature in } ^\circ\text{F plus } 460^\circ). \end{array} \right\}$$

With dry air at 29.9 inches mercury, air velocity can be read directly from curves on the following page. For partially or fully saturated air a further correction is required. To save time when converting velocity pressure into air velocity, the Dwyer® Air Velocity Calculator may be used. A simple slide rule, it provides for all the factors needed to calculate air velocity quickly and accurately. It is included as an accessory with each Dwyer® Pitot tube.

To use the Dwyer® Calculator:

1. Set relative humidity on scale provided. On scale opposite known dry bulb temperature, read correction factor.
2. Set temperature under barometric pressure scale. Read density of air over correction factor established in 1 (above).
3. On the other side of calculator, set air density reading just obtained on the scale provided.
4. Under Pitot tube reading (velocity pressure, inches of water) read air velocity, feet per minute.

## DETERMINING VOLUME FLOW

Once the average air velocity is known, the air flow rate in cubic feet per minute is easily computed using the formula:

$$Q = AV$$

Where: Q = Quantity of flow in cubic feet per minute.  
 A = Cross sectional area of duct in square feet.  
 V = Average velocity in feet per minute.

## DETERMINING AIR VOLUME BY CALIBRATED RESISTANCE

Manufacturers of air filters, cooling and condenser coils and similar equipment often publish data from which approximate air flow can be determined. It is characteristic of such equipment to cause a pressure drop which varies proportionately to the square of the flow rate. Figure 5 shows a typical filter and a curve for air flow versus resistance. Since it is plotted on logarithmic paper, it appears as a straight line. On this curve, a clean filter which causes a pressure drop of .50 in w.c. would indicate a flow of 2,000 c.f.m.

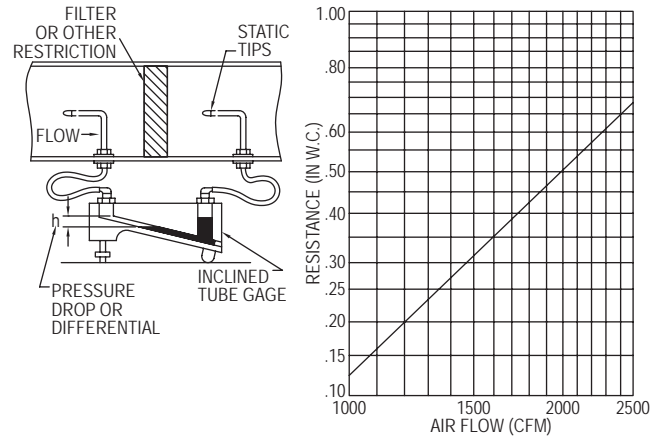

Figure 5 - Differential measurement across duct restriction

For example, assuming a manufacturer's specification for a filter, coil, etc:

Given Flow Q (ft<sup>3</sup>/min.) = at differential "h" (inches w.c.)

To determine flow at other differentials the formula is:

$$Q_n (\text{other flows}) = Q \sqrt{\frac{h_n}{h}}$$

Where: Q = Quantity of flow in cubic feet per minute  
 h = Differential in inches water column  
 $h_n$  = Differential (other flow conditions)

## OTHER DEVICES FOR MEASURING AIR VELOCITY

A wide variety of devices are commercially available for measuring air velocities. These include hot wire anemometers for low air velocities, rotating and swinging vane anemometers and variable area flowmeters.

The Dwyer® No. 460 Air Meter is one of the most popular and economical variable area flowmeter type anemometers. Quick and easy to use, it is a portable instrument calibrated to provide a direct reading of air velocity.

A second scale is provided on the other side of the meter to read static pressure in inches w.c. The 460 Air Meter is widely used to determine air velocity and flow in ducts, and from supply and return grilles and diffusers. Two scale ranges are provided (high and low) with calibrations in both f.p.m. and in w.c.

## TO CHECK ACCURACY

Use only devices of certified accuracy. All anemometers and to a lesser extent portable manometers should be checked regularly against a primary standard such as a hook gage or high quality micromanometer. If in doubt return your Dwyer® instrument to the factory for a complete calibration check at no charge.

## HVAC MOBILE APPLICATION

Easily converts velocity pressure to air velocity or air velocity to air volume for most Android® or iOS devices.

## FREE DOWNLOAD!

Download the phone App or use the Web version of our Air Velocity and Flow Calculator on our website at: [www.dwyer-inst.com/flowcalc](http://www.dwyer-inst.com/flowcalc).





# AIR VELOCITY FLOW CHARTS

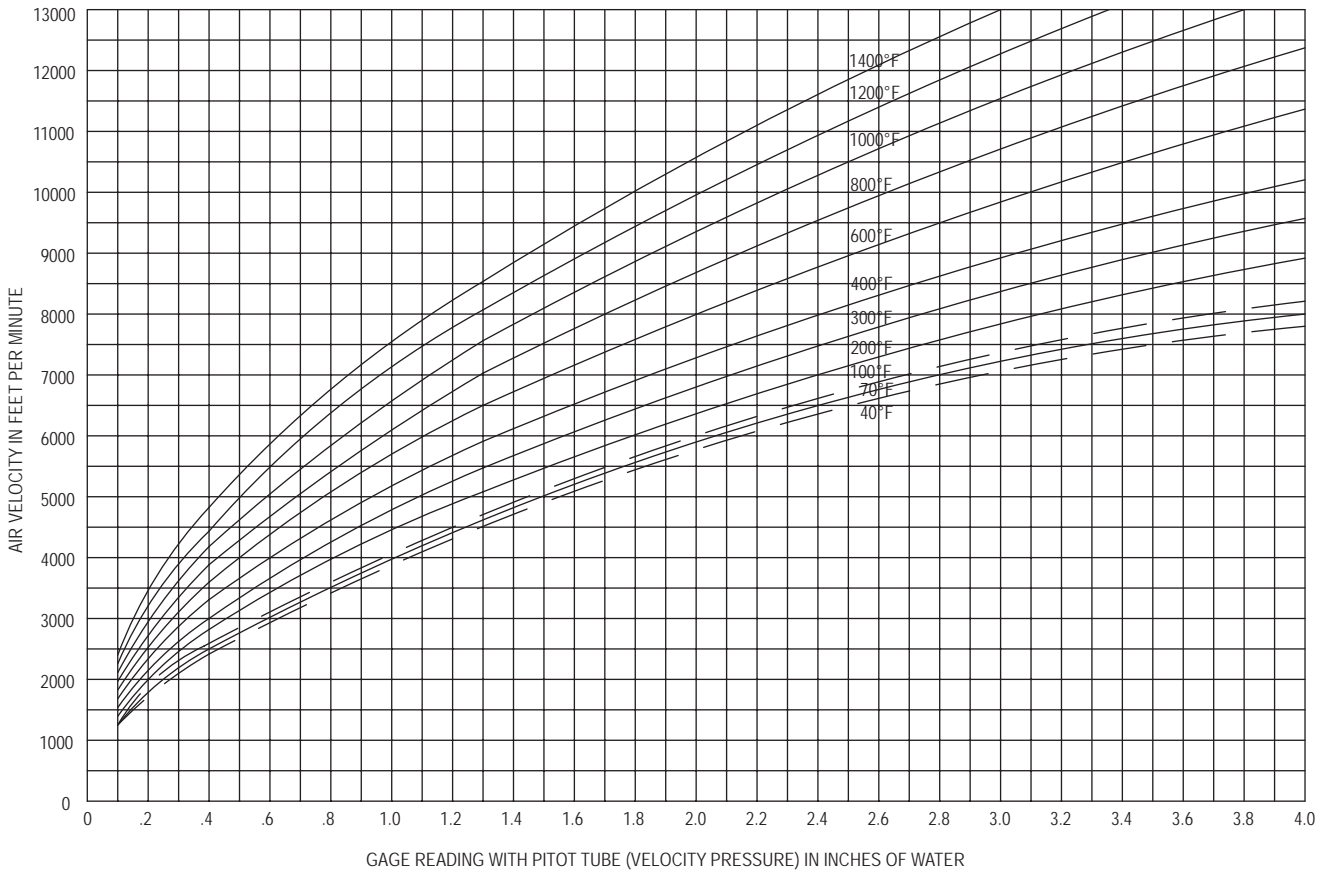
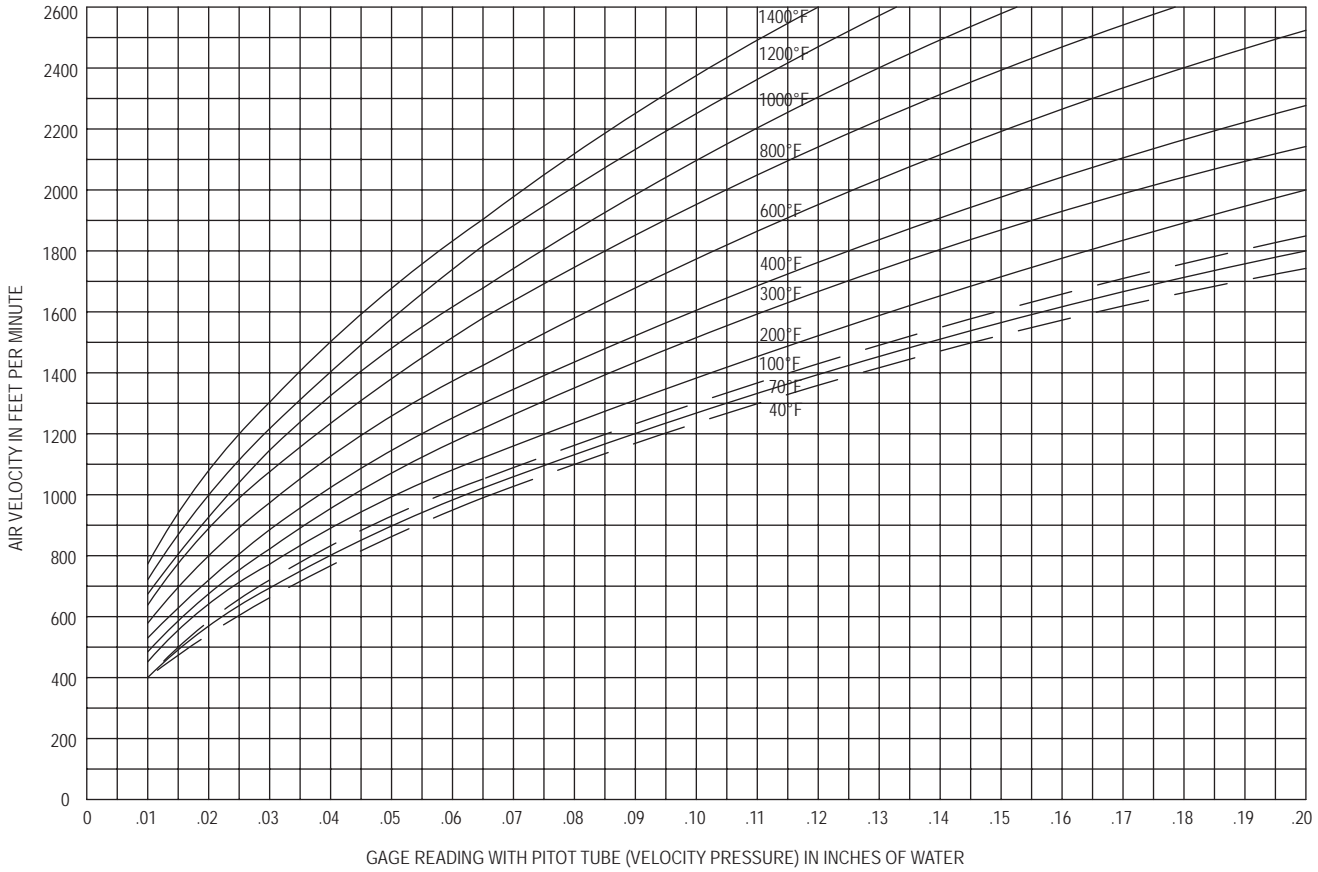

# AIR BALANCING HVAC SYSTEMS

## METHODS OF AIR BALANCING

Air balancing a distribution system is needed to properly direct the air flow in order to optimize the system's design. Flow rates are tested, adjusted, and balanced as cubic feet per minute (CFM) or cubic meters per hour (m<sup>3</sup>/h). There are two traditional methods for balancing airflow at the terminals. The first is sequential balancing, which involves setting the zone and branch dampers in sequence. However, the most common method of air balancing is called proportional balancing.

For traditional proportional balancing, an air flow hood, or capture hood, is the most popular test instrument used to take air flow readings. Traverse readings in the duct with a Pitot tube or a hot-wire thermo-anemometer is another accepted method of capturing the actual air flow.

Dwyer has designed a variation of proportional balancing, which is called Predictive Balancing used in Dwyer's Series SAH SMART Air Hood® Balancing Instrument. Predictive Balancing is designed to be a faster process and give more accurate results than traditional proportional balancing.

## PREDICTIVE VS PROPORTIONAL BALANCING

In traditional proportional balancing, the flow hood will directly measure volumetric air flow at the outlets or terminals of a system: the registers, grilles, and diffusers. Most air flow hoods are cone shaped and aligned to the ceiling registers as shown in Figure 1 in the left picture. When a flow hood is placed over a terminal, it will generate pressure within the duct system, which reduces the air flow to the terminal. This condition is called back pressure. The effect of back pressure can result in errors when taking readings. Before using a flow hood, many technicians recommend performing a duct traverse to verify the K factor. Some digital flow hoods include back pressure compensation that attempts to calculate the effect of backpressure for the technician.

Dwyer's Predictive Balancing technique is based on mass balance and energy conservation methods. Predictive Balancing, is a process that involves predicting the ideal flow set points for each TUA (Terminal Under Adjustment) so that every terminal is at the target flow until the process is complete. Dwyer's Series SAH SMART Air Hood® Balancing Instrument was designed with Predictive Balancing in mind. Dwyer's air hood is being used in Figure 1 in the right picture.

Predictive Balancing is deterministic and minimizes the number of process steps involved in testing, adjusting, and balancing HVAC systems. Figure 2 illustrates a comparison between Predictive Balancing and traditional proportional balancing processes, showing how much faster Predictive Balancing is.



Figure 1 – Traditional air flow hood (left picture) versus Dwyer SMART Air Hood® balancing instrument (right picture)

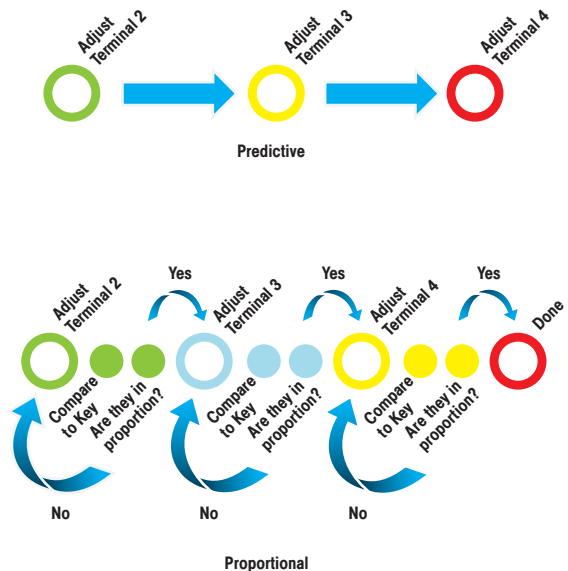

Figure 2 – Predictive vs Proportional Balancing



# AIR BALANCING HVAC SYSTEMS

## PROPORTIONAL BALANCING

With proportional balancing (reference Figure 3), the technician balances a terminal proportional to the key terminal. To start a proportional balance of a system, one requirement is that the system has an 80% to 120% rate to the total design flow. Systems that are higher or lower than this range will not balance properly. If the system is outside of this range, the fan speed should be adjusted to get within range. Once set, the air flow from each terminal will remain the same ratio to other terminals.

If key Terminal 1 has a design flow percent of 60%, then Terminal 2 is 57%, Terminal 3 is 65%, and the ratio to the key Terminal 1 is  $57\% / 60\% = 0.95$ . Meaning Terminal 2 will deliver 95% of the air volume of Terminal 1. With Terminal 1 as the key, delivering 100% of design flow, then Terminal 2 will be delivering 95% of the design flow. This will meet the design requirements. For example, if the damper for Terminal 3 is adjusted down to 525 CFM, the flow from Terminal 1 may increase to 550 CFM. In this case, Terminal 2 is within the design range;  $550 * 0.95 = 523$  CFM.

Once the terminals are in balance, with the proper ratio of tolerance with each other, they remain in balance with each other even though the air volume may change. All terminals in the system are then proportionally balanced. The fan RPM can be set to deliver the intended total air volume and all terminals will deliver the design flow within the established tolerances.

This process requires the balancing technician to adjust the flow from the terminal under-adjustment (TUA) to the key to gain the correct flow proportion. The key terminal's flow changes when the TUA damper is changed. It may take several iterations to achieve the proper flow proportion.

Since the technician is estimating where to set the flow rate of the TUA relative to the key, the tolerance can vary considerably, which limits the accuracy of the balancing. The illustration in Figure 3 shows the potential number of lengthy steps involved with proportional balancing.

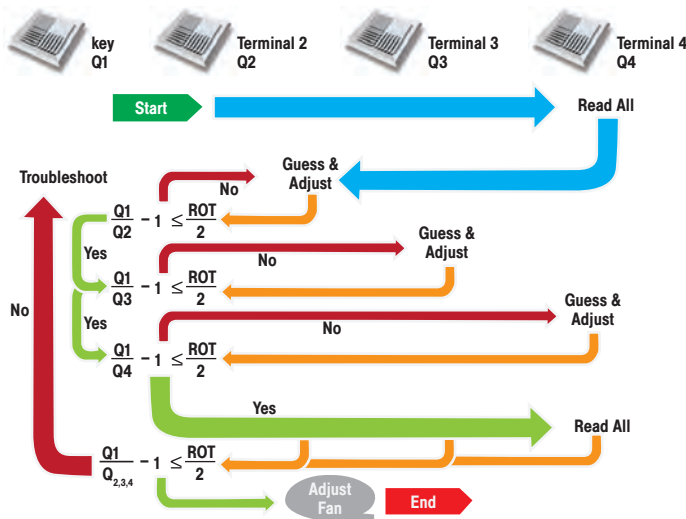

Figure 3 – Proportional balancing

## PREDICTIVE BALANCING

The Predictive Balancing (reference Figure 4) process begins by opening the dampers to capture the total flow. The total flow is distributed into the four terminal flows. The terminal flows are determined by the terminal and damper loads and the pressure drop in the system.

Terminal 2 is the first damper adjusted in the system, and Terminal 1 is the key. Predictive Balancing calculates the ideal flow set point for Terminal 2 for TUA and predicts flows for Terminals 1, 3, and 4.

After adjusting the Terminal 2 flow to the ideal flow set point, Predictive Balancing calculates the ideal set point for Terminal 3 and predicts the new flows for terminals 1, 2, and 4.

To finish, Predictive Balancing calculates the ideal set point for the last Terminal, number 4, and flows for Terminals 1, 2, and 3 are correctly proportioned to the target.

Finally, Predictive Balancing calculates the ideal flow for Terminal 4 so the blower flow can be adjusted to bring all the terminal flows to the target flows.

Predictive Balancing also monitors and compensates for load on the blower/fan from the damper closures during the balancing process. The illustration in Figure 4 compared to Figure 3 shows just how much easier and faster Predictive Balancing is over Proportional Balancing in the amount of steps involved in the process.

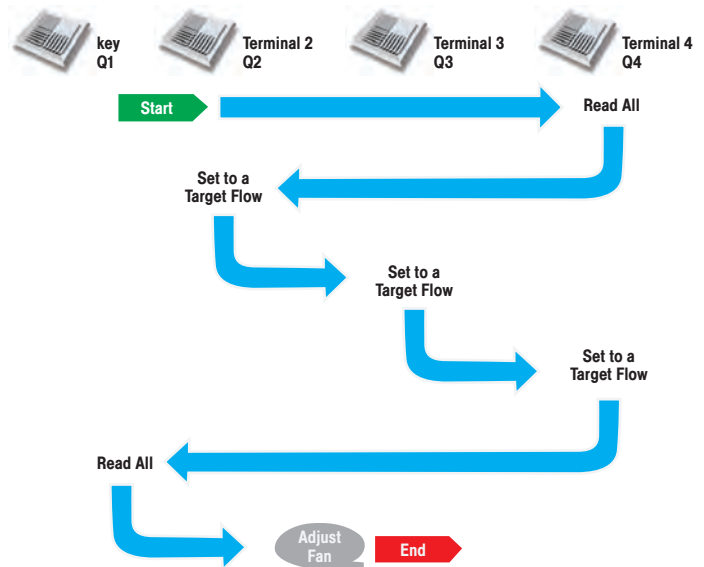

Figure 4 – Predictive balancing

**Dwyer**  
SERIES SAH

# SMART AIR HOOD® BALANCING INSTRUMENT

Quad Flow Design Technology, Predictive Balancing



DEALER DESIGN  
AWARDS

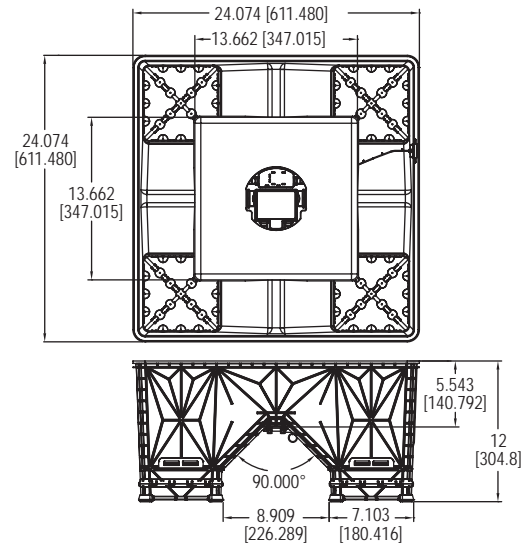

The **Series SAH SMART Air Hood® Balancing Instrument** is the most accurate and easy to operate air flow hood on the market. By using the included hood stand and wireless communications to the handheld, a single operator can balance a branch in less time than traditional balancing teams. Besides being lighter than most traditional capture hoods, the ergonomic design makes the Series SAH easy to maneuver, with less physical stress. The rugged polypropylene base hood features patented Quad Flow Design Technology for controlling air flow and minimizing back pressure, which yields superior measurement accuracy. The Wi-Fi direct communication gives reliable communication with a distance of up to 200 yards (183 m) between the hood and the handheld test instrument. The SMART Air Hood® Balancing Instrument includes the PredictAir™ Application Software which reduces the number of steps in the air flow balancing process using Predictive Balancing's Express Balance mode. Predictive Balancing is a method of predicting the optimal flow set point for each register and the order in which they should be adjusted.

## FEATURES/BENEFITS

- Patent pending Quad Flow Design Technology directs the circulating air patterns to provide a more even air flow that minimizes backpressure enabling accurate readings
- Patent pending Predictive Balancing is a process that guides the balancing technician on setting the optimal flow set point for each sequential terminal. With the PredictAir™ Application Software, the balancing process takes much less time than traditional air balancing methods
- The ergonomic design is much lighter and easier to work with than the existing bulky air hoods, providing greater maneuverability and less physical strain. One technician can complete the air balancing
- Wi-Fi direct wireless communication provides a range up to 200 yards (183 m) line of sight

## APPLICATIONS

- Commissioning, testing, adjusting and balancing volumetric air flow from diffusers, grilles, and registers in HVAC systems

## INCLUDED WITH THE SAH-22-IN:

- Handheld Test Instrument preloaded with PredictAir™ App
- 3' (0.9 m) extendable pole
- Handheld quick release pole adapter kit
- SAH roller travel case with instrument available foam inserts
- Charging cables for SAH and handheld
- Lithium ion battery
- Installation and operating manual
- NIST Traceable Certificate

## SPECIFICATIONS

### SAH SPECIFICATIONS

**Service:** Air.

**Units:** CFM, m<sup>3</sup>/h, l/s.

**Volume Flow Ranges:** Supply: 40 to 2000 CFM (68 to 3398 m<sup>3</sup>/h) (19 to 944 l/s); Exhaust: 80 to 2000 CFM (136 to 3398 m<sup>3</sup>/h) (38 to 944 l/s).

**Accuracy > 40 CFM:** ±3% of reading ±7 CFM (11.9 m<sup>3</sup>/hr) (3.3 l/s).

**Resolution:** 1 CFM (1.7 m<sup>3</sup>/h) (.5 l/s).

**Power Requirements:** 3.6 V NCR18650B MH12210 lithium ion battery, included, user replaceable or (4) 1.5 V AA alkaline batteries, not included, user replaceable.

**Housing Material:** Polypropylene.

**Weight:** 5.75 lb (2.6 kg).

**Agency Approvals:** CE, FCC, IC.

### HANDHELD SPECIFICATIONS

**Operating System:** PredictAir™ Application Software only available with factory supplied test instrument.

**Wireless Protocol:** Wi-Fi direct low energy wireless technology.

**Response Time:** 1 s.

Updates to diffuser library can be downloaded using Google Play™ store.

## MODEL CHART

Model	Description
SAH-22	SMART Air Hood® Balancing Instrument with 2' x 2' (0.6 m x 0.6 m) opening
A-SAH-12P	4.5' to 12' (1.4 m x 3.7 m) extendable pole <b>(Required for operation)</b>
SAH-22HC	SMART Air Hood® Balancing Instrument with 2' x 2' (0.6 m x 0.6 m) opening, with hard travel case

## ACCESSORIES

Model	Description
A-SAH-14S	Canvas hood 1' x 4' (0.3 m x 1.2 m)
A-SAH-24S	Canvas hood, 2' x 4' (0.6 m x 1.2 m)
A-SAH-33S	Canvas hood, 3' x 3' (0.9 m x 0.9 m)
A-SAH-15S	Canvas hood, 1' x 5' (0.3 m x 1.5 m)
A-SAH-BK	SAH adapter base kit for canvas hood
A-SAH-CK	Spare calibration kit with four Quad Flow Sensing Grids and Sensor Module
A-SAH-12P	4.5' to 12' (1.4 m x 3.7 m) extendable pole
NISTCALM-SAH	Re-certification service. Please contact your regional Dwyer distributor or Dwyer International Sales Office for scheduling your NIST recertification
A-SAH-22HC	Hard carrying case for SAH

**Note: For full functionality and versatility, the A-SAH-12P is required for operation of all SAH models.**



# AIR QUALITY TEST INSTRUMENT KITS

AQTIA Combines the UHH2 Universal Handheld with Compatible Probes

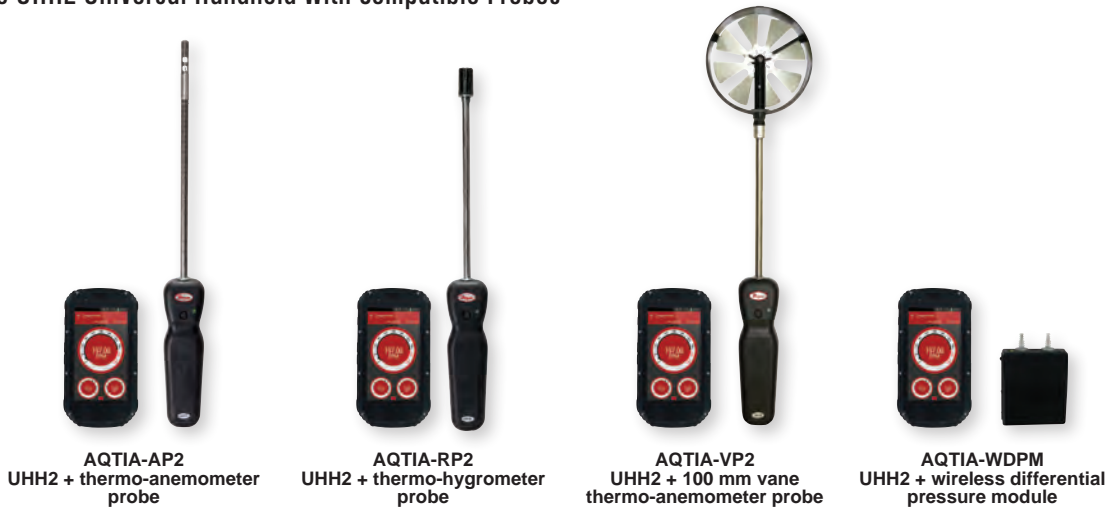

The Series AQTIA Air Quality Test Instrument Kits combine the versatile Model UHH2 handheld base with various compatible probes and modules. The versatile combination provides a line of instruments capable of streamlining a technician's everyday testing by combining all into one product and using Bluetooth SIG, Inc. wireless technology for ease of use.

**FEATURES/BENEFITS**

- Rugged IP68 housing withstands 1.5 meter drop test
- Wireless measurement of pressure, air velocity, air flow, temperature, and humidity

**APPLICATIONS**

- Building commissioning
- Building balancing
- Testing HVAC equipment performance

**SPECIFICATIONS**

**Display:** 4.3" QHD Gorilla glass, 960x540.  
**Temperature Limits:** Operating: -4 to 140°F (-20 to 60°C); Storage: -40 to 176°F (-40 to 80°C).  
**Humidity Limits:** 5 to 95% RH.  
**Power Requirements:** 2000 mAh lithium ion battery, installed functional, non-replaceable.  
**Memory:** RAM 1G & ROM 4G.  
**Operating System:** Android 4.2.2.  
**CPU:** MTK6589W Quad Core 1.2 GHz.  
**Enclosure Rating:** IP68.  
**Weight:** 15.9 oz (450 g).  
**Agency Approvals:** CE.

MODEL CHART			
Model	Parameters	Range	Engineering Units Available
AQTIA-AP2	Velocity/temperature	0 to 6000 FPM; -20 to 212°F	Velocity: fps, fpm, mph, knots, m/s, m/h, k/h; Temperature: °F, °C, °K
AQTIA-RP2	Humidity/temperature	0 to 100% RH; -20 to 140°F	Humidity: %RH; Temperature: °F, °C, °K
AQTIA-VP2	Velocity/RH/temperature	40 to 5000 FPM; 0 to 100% RH; -4 to 140°F	Velocity: fps, fpm, mph, knots, m/s, m/h, k/h; Temperature: °F, °C, °K
AQTIA-WDPM-002	Pressure	±2 in w.c. (498.18 Pa)	in w.c., ft w.c., in Hg, psi, oz/in <sup>2</sup> ; mm w.c., cm w.c., mbar, Pa, hPa, kPa
AQTIA-WDPM-005	Pressure	±5 in w.c. (1245.4 Pa)	in w.c., ft w.c., in Hg, psi, oz/in <sup>2</sup> ; mm w.c., cm w.c., mbar, Pa, hPa, kPa
AQTIA-WDPM-010	Pressure	±10 in w.c. (2490.9 Pa)	in w.c., ft w.c., in Hg, psi, oz/in <sup>2</sup> ; mm w.c., cm w.c., mbar, Pa, hPa, kPa
AQTIA-WDPM-020	Pressure	±20 in w.c. (4981.8 Pa)	in w.c., ft w.c., in Hg, psi, oz/in <sup>2</sup> ; mm w.c., cm w.c., mbar, Pa, hPa, kPa
AQTIA-WDPM-030	Pressure	±30 in w.c. (7472.7 Pa)	in w.c., ft w.c., in Hg, psi, oz/in <sup>2</sup> ; mm w.c., cm w.c., mbar, Pa, hPa, kPa
AQTIA-WDPM-100	Pressure	±100 in w.c. (24909 Pa)	in w.c., ft w.c., in Hg, psi, oz/in <sup>2</sup> ; mm w.c., cm w.c., mbar, Pa, hPa, kPa
AQTIA-WDPM-200	Pressure	±200 in w.c. (49818 Pa)	in w.c., ft w.c., in Hg, psi, oz/in <sup>2</sup> ; mm w.c., cm w.c., mbar, Pa, hPa, kPa
AQTIA-WDPM-350	Pressure	±350 in w.c. (87181 Pa)	in w.c., ft w.c., in Hg, psi, oz/in <sup>2</sup> ; mm w.c., cm w.c., mbar, Pa, hPa, kPa

**Note:** AQTIA series models supplied with: UHH2, UHH-BTG, wireless sensing probe, soft carrying case (UHH-C1), charging cable (UHH-CBL2), and headphones.  
**Note:** Pro series models supplied with: UHH2, UHH-BTG, wireless sensing probe, soft carrying case (UHH-C1), charging cable (UHH-CBL2), headphones, heavy duty hard case with pre-cut foam inserts for additional sensors (UHH-C2), and NIST calibration certificate. For pro series models, replace AQTIA with AQTIA-P.

MODEL CHART - PROFESSIONAL KITS				
Model	Probes Provided	Parameters	Range	Engineering Units Available
AQTIA-P-WDPM-002-PKIT	WDPM-002	Pressure	±2 in w.c. (498.18 Pa)	in w.c., ft w.c., in Hg, psi, oz/in <sup>2</sup> ; mm w.c., cm w.c., mbar, Pa, hPa, kPa
	AP2	Velocity/temperature	0 to 6000 FPM; -20 to 212°F	Velocity: fps, fpm, mph, knots, m/s, m/h, k/h; Temperature: °F, °C, °K
	RP2	Humidity/temperature	0 to 100% RH; -20 to 140°F	Humidity: %RH; Temperature: °F, °C, °K
	VP2	Velocity/RH/temperature	40 to 5000 FPM; 0 to 100% RH; -4 to 140°F	Velocity: fps, fpm, mph, knots, m/s, m/h, k/h; Temperature: °F, °C, °K
AQTIA-P-WDPM-005-PKIT	WDPM-005	Pressure	±5 in w.c. (1245.4 Pa)	in w.c., ft w.c., in Hg, psi, oz/in <sup>2</sup> ; mm w.c., cm w.c., mbar, Pa, hPa, kPa
	AP2	Velocity/temperature	0 to 6000 FPM; -20 to 212°F	Velocity: fps, fpm, mph, knots, m/s, m/h, k/h; Temperature: °F, °C, °K
	RP2	Humidity/temperature	0 to 100% RH; -20 to 140°F	Humidity: %RH; Temperature: °F, °C, °K
	VP2	Velocity/RH/temperature	40 to 5000 FPM; 0 to 100% RH; -4 to 140°F	Velocity: fps, fpm, mph, knots, m/s, m/h, k/h; Temperature: °F, °C, °K
AQTIA-P-WDPM-010-PKIT	WDPM-010	Pressure	±10 in w.c. (± 2.5 kPa)	in w.c., ft w.c., in Hg, psi, oz/in <sup>2</sup> ; mm w.c., cm w.c., mBar, Pa, hPa, and kPa
	AP2	Velocity/temperature	0 to 6000 FPM; -20 to 212°F	Velocity: fps, fpm, mph, knots, m/s, m/h, k/h; Temperature: °F, °C, °K
	RP2	Humidity/temperature	0 to 100% RH; -20 to 140°F	Humidity: %RH; Temperature: °F, °C, °K
	VP2	Velocity/RH/temperature	40 to 5000 FPM; 0 to 100% RH; -4 to 140°F	Velocity: fps, fpm, mph, knots, m/s, m/h, k/h; Temperature: °F, °C, °K

**Note:** Full professional kits supplied with UHH2, UHH-BTG, AP2 thermo-anemometer probe, RP2 thermo-hygrometer probe, VP2 thermo-anemometer probe, WDPM wireless differential pressure module, 160-18 stainless steel pitot tube, 160F straight stainless steel pitot tube, 160G averaging air flow grid, (2) A-303 portable static pressure tip, soft carrying case (UHH-C1), charging cable (UHH-CBL2), headphones, heavy duty hard case with pre-cut foam inserts for additional sensors (UHH-C2), and NIST calibration certificates.



# MOBILE METER® SOFTWARE TEST INSTRUMENT APP

Works With Most Android® and iOS® Phones/Tablets; Wireless Probes



Touch to access parameters

Connection status



Touch to toggle between meter and gage view

The **Mobile Meter® Software Test Instrument App** converts Android® and iOS® based phones and tablets into a multi-function test instrument. Wireless probes connect to the phone or tablet using our mobile gateway, Model UHH-BTG, which utilizes wireless technology from Bluetooth SIG Inc. Parameters from multiple probes can be displayed simultaneously, or a single probes parameters can be displayed as a meter or analog gage.

### FEATURES/BENEFITS

- Available on Android® and iOS® devices
- Data logging feature records measurements from a single probe and can email reports directly from device
- Display multiple parameters in gage or meter display

### SPECIFICATIONS

**Operating Systems:** Android® firmware version 3.X or later, iOS® firmware version 5.X or later.  
**Wireless Protocol:** Conforms to Bluetooth SIG, Inc. low energy wireless technology.  
**Wireless Distance:** 50' (15 m) or greater.  
**Response Time:** 1 s.

### APPLICATIONS

- Building balancing
- Building commissioning
- Testing HVAC equipment performance

## MODEL UHH-BTG

# WIRELESS MOBILE GATEWAY

Converts UHH Probe Wireless Signals to Bluetooth SIG, Inc. Wireless Technology

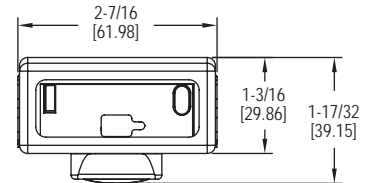
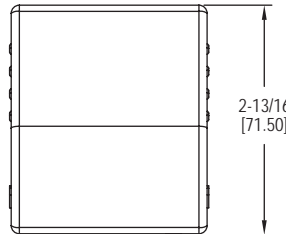

The **Model UHH-BTG Wireless Mobile Gateway** transforms the wireless signal from any Dwyer Instruments, Inc. universal handheld probe or module into a Bluetooth SIG, Inc. Wireless Technology. Using this gateway, any iOS® Firmware version 5.X or later or Android® Firmware Version 3.X or later smartphone or tablet can become the base instrument for measuring or logging. Once the gateway is paired with a device, our Mobile Meter® Software Mobile App or any other Dwyer Instruments, Inc. approved apps can detect available probes or modules.

### FEATURES/BENEFITS

- Detects probes/modules from 50 ft (15 m) away
- Compact size with belt clip for carrying around
- Can be recharged using the same mini-USB cable and charger as probes/modules

### APPLICATIONS

- Building balancing
- Building commissioning
- Testing HVAC equipment performance

### SPECIFICATIONS

**Wireless Protocol:** Conforms to Bluetooth SIG, Inc. low energy wireless technology.  
**Wireless Distances:** 50' (15 m) or greater.  
**Response Time:** 1 s.  
**Temperature Limits:** Ambient: 5 to 125°F (-15 to 51°C); Battery charging: 32 to 113°F (0 to 45°C).  
**Power Requirements:** 3.7 V YT562447 lithium ion battery, installed functional, user replaceable.  
**Weight:** 2.5 oz (70.87 g).  
**Agency Approvals:** CE with CE approved charger, FCC.

### MODEL CHART

Model	Description
UHH-BTG	Wireless mobile gateway

### ACCESSORIES

Model	Description
UHH-ICHRG	Dual USB charger

### MODEL CHART - CONVERTS THESE WIRELESS PROBES FOR USE WITH OUR MOBILE METER® SOFTWARE MOBILE APP

Model	Description
AP2	Wireless thermo-anemometer probe
RP2	Wireless thermo-hygrometer probe
VP2	Wireless 100 mm vane thermo-anemometer probe
WDPM-002	Wireless differential pressure probe ±2 in w.c.
WDPM-005	Wireless differential pressure probe ±5 in w.c.
WDPM-010	Wireless differential pressure probe ±10 in w.c.
WDPM-020	Wireless differential pressure probe ±20 in w.c.
WDPM-030	Wireless differential pressure probe ±30 in w.c.
WDPM-100	Wireless differential pressure probe ±100 in w.c.
WDPM-200	Wireless differential pressure probe ±200 in w.c.
WDPM-350	Wireless differential pressure probe ±350 in w.c.

Note: See wireless probe catalog page on the web for full specifications.



Google Inc.® is a registered trademark of Google, Inc.  
 Google® is a registered trademark of Google, Inc.  
 iOS® is a registered trademark of Cisco Systems, Inc.  
 Google Play™ is a trademark of Google, Inc.

● Wireless Probes: See page 168 (Models RP2, AP2 & VP2)

# TRAVERSEIT™ AIR VELOCITY MEASURING SOFTWARE APPLICATION

Includes ISO Standard Calculated Flow, Duct Traverse Procedure, Reporting



AP2

The **TraverseIT™ Air Velocity Measuring Software Application** displays air flow measurements from Dwyer's Series WDPM Wireless Differential Pressure Module or Series AP2 Hot Wire Thermo-Anemometer Probe and guides balancers through the duct traverse process using step-by-step instructions. The traverse process is a method for calculating the maximum airflow in a duct. Several readings are taken across a traverse plane which are converted into velocity, and averaged. The TraverseIT™ app calculates air flow using ISO 3966 and 5801 standards, yielding highly accurate flow readings with each traverse. The application comes factory installed on a Dwyer rugged handheld unit that is included with a variety of balancing instruments or it can be downloaded directly from the Google Play™ store.

### SPECIFICATIONS

**Operating System:** Android™ 4.2.2 (Jellybean or newer).\*  
**Wireless Protocol:** Bluetooth® wireless technology.  
**Response Time:** 1 s.

\*Latest updates to application can be downloaded using the Google Play™ store.

### FEATURES/BENEFITS

- Step-through traverse procedure provides duct visuals for quick and proper setup
- Utilizes ISO Standards to calculate high accurate flow
- Generates and shares duct traverse reports directly from the handheld device

### APPLICATIONS

- Commissioning, testing, adjusting and balancing volumetric air flow in HVAC systems

Google Play™ is a trademark of Google, Inc.

## SERIES 160FW

# WIRELESS STRAIGHT PITOT TUBES

Wireless, Measures Differential Pressure, Air Velocity and Flow

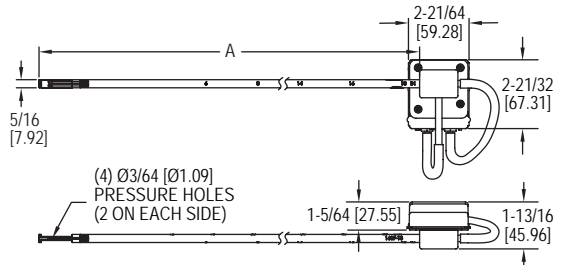

DIMENSIONS	
Model	Dimension "A" in (mm)
160FW-18	19-9/32 (489.56)
160FW-24	25-9/32 (642.14)
160FW-36	37-9/32 (946.94)
160FW-48	49-9/32 (1251.74)
160FW-60	61-9/32 (1556.54)

**Series 160FW Wireless Pitot Tubes** are designed to meet the need of the environmental field testing and is an accurate and reliable way to measure the flow of air or gas streams. Combined with the universal handheld and UHH gateway, the 160FW wireless capability allow users to read velocity directly on the handheld in the Mobile Meter® App. This universal pitot tube can also be used to take duct traverses when used with Dwyer's TraverseIT™ App. Data can be logged and sent via email for later reporting.

### FEATURES/BENEFITS

- Compatible with Dwyer's Mobile Meter® and TraverseIT™ applications
- Stable 50' (15 m) wireless range
- Straight design allows for easy insertion into ducts
- Permanent stamped insertion depth graduations facilitate accurate positioning
- Alignment indicator helps keep tip parallel to flow

### APPLICATIONS

- Monitor or control air velocity or air flow where hook style pitot tubes don't allow access
- Building commissioning
- Building HVAC test and balance

### SPECIFICATIONS

**Wetted Material:** 304 SS.  
**Accuracy:** ±0.5% FS span @ 25°C (includes non linearity, hysteresis, and non repeatability).  
**Pressure Limit:** ±2 in w.c. (±500 Pa).  
**Compensated Temperature Limits:** 32 to 140°F (0 to 60°C).  
**Pitot Tube Range:** 0 to 9000 FPM (45 m/s).  
**Pitot Tube K-Factor:** 0.81.  
**Process Temperature Limit:** 1500°F (815°C).  
**Process Connections:** 1/4" OD.  
**Weight:** 2 lb (0.91 kg) (weight varies depending on pitot tube length).

### MODEL CHART

Model	Description
160FW-18	18" wireless straight stainless steel pitot tube
160FW-24	24" wireless straight stainless steel pitot tube
160FW-36	36" wireless straight stainless steel pitot tube
160FW-48	48" wireless straight stainless steel pitot tube
160FW-60	60" wireless straight stainless steel pitot tube



MODEL RP2

# THERMO-HYGROMETER PROBE

Wireless, Measures Humidity, Temperature, Dew Point, and Wet Bulb Temperatures

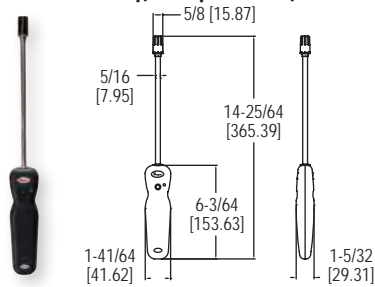

SPECIFICATIONS	
<b>Service:</b> Clean air.	<b>Probe Length:</b> 8" (203 mm) insertion.
<b>Temperature Limits:</b> Process: -4 to 140°F (-20 to 60°C); Ambient: 5 to 125°F (-15 to 51°C);	<b>Power Requirements:</b> 3.7 V YT562447 Lithium ion battery, installed functional, user replaceable. ( <b>Note:</b> Intended to be operated with power cables less than 3 m in length). (Wireless Only).
<b>Battery Charging:</b> 32 to 113°F (0 to 45°C).	<b>Maximum Wireless Distance:</b> 50' (15 m).
<b>Range:</b> RH: 0 to 100% (non-condensing); Temperature: -22 to 140°F (-30 to 60°C).	<b>Handle Enclosure:</b> Thermoplastic elastomer over polycarbonate.
<b>Accuracy:</b> RH: ±2% @ 25°C (10 to 90% RH); ±4% (0 to 10, 90 to 100% RH); Temperature: ±0.54°F @ 77°F (±0.3°C @ 25°C).	<b>Supplied With:</b> Wrist strap.
<b>Response Time:</b> 1.5 s.	<b>Weight:</b> 11.2 oz (331.22 g).
	<b>Agency Approvals:</b> CE (not while charging), FCC compliant.

**FEATURES/BENEFITS**

- Allows for one handed operation for ladder use safety
- Stable 50 ft (15 m) wireless range

**APPLICATIONS**

- Building Commissioning
- Building HVAC test and balance

MODEL CHART	
Model	Description
RP2	Wireless thermo-hygrometer probe for use with the Model UHH handheld meter and the Mobile Meter® Software Test Instrument Mobile App

MODEL AP2

# THERMO-ANEMOMETER PROBE

Wireless, Measures Velocity, Flow, and Temperature

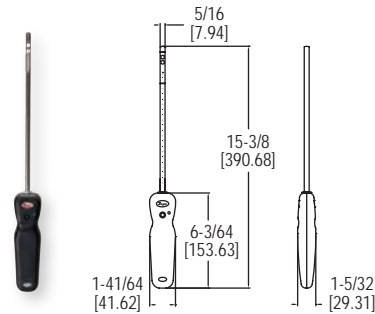

SPECIFICATIONS	
<b>Service:</b> Dry, clean air.	<b>Battery Charging Limits:</b> 32 to 113°F (0 to 45°C). (Wireless Only).
<b>Temperature Limits:</b> Process: -20 to 212°F (-29 to 100°C); Ambient: 5 to 125°F (-15 to 51°C).	<b>Power Requirements:</b> 3.7 V YT562447 Lithium ion battery, installed functional, user replaceable. ( <b>Note:</b> Intended to be operated with power cables less than 3 m in length). (Wireless Only).
<b>Range:</b> Air Velocity: 0 to 6000 FPM (0 to 30 m/s); Volumetric Air: 999,999 in selected flow units; Temperature: -20 to 212°F (-29 to 100°C).	<b>Maximum Wireless Distance:</b> 50' (15 m). (Wireless Only).
<b>Accuracy:</b> Air Velocity: ±3% FS within temperature range of 40 to 90°F (4 to 32°C) -TAB option: 50 to 3900 FPM (0.25 to 20m/s); Temperature: ±0.5°F (±0.28°C).	<b>Handle Enclosure:</b> Thermoplastic elastomer over polycarbonate.
<b>Response Time:</b> 1 s.	<b>Supplied With:</b> Wrist strap.
<b>Probe Length:</b> 8" (203 mm) insertion.	<b>Weight:</b> 11.2 oz (317 g).
	<b>Agency Approvals:</b> CE (not while charging), FCC compliant.

**FEATURES/BENEFITS**

- Allows for one handed operation for ladder use safety
- Stable 50 ft (15 m) wireless range

**APPLICATIONS**

- Building Commissioning
- Building HVAC test and balance

MODEL CHART	
Model	Probe Length
AP2	8" (203.2 mm)
AP2-18	18" (457.2 mm)
AP2-24	24" (609.6 mm)
AP2-36	36" (914.4 mm)

MODEL VP2

# 100 MM VANE THERMO-ANEMOMETER PROBE

Wireless, Measures Velocity, Flow, Humidity, and Temperature

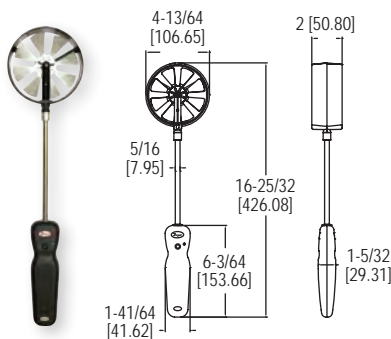

SPECIFICATIONS	
<b>Service:</b> Dry, clean air.	<b>Response Time:</b> Air Velocity and Air Volume: 1 s; Temperature and Relative Humidity: 1.5 s.
<b>Temperature Limits:</b> Process: -20 to 212°F (-29 to 100°C); Ambient: 5 to 125°F (-15 to 51°C).	<b>Probe Length:</b> 8" (203 mm) insertion.
<b>Range:</b> Air Velocity: 40 to 5000 FPM (0.2 to 25 m/s); Volumetric Air: 999,999 in selected flow units; Temperature: -20 to 212°F (-29 to 100°C); Relative Humidity: 0 to 100% RH.	<b>Battery Charging Limits:</b> 32 to 113°F (0 to 45°C). (Wireless Only).
<b>Accuracy:</b> Air Velocity: 0.25 to 10 m/s: ±1.5% of reading ±20 FPM (±0.1 m/s); 10 to 20 m/s: 1.5% of reading ±40 FPM (±0.2 m/s); 20 to 25 m/s: ±1.5% of reading ±60 FPM (±0.3 m/s); Temperature: ±0.54°F @ 77°F (±0.3°C @ 25°C); Relative Humidity: ±2% @ 77°F (25°C) (10 to 90% RH); ±4% (0 to 10% RH and 90 to 100%).	<b>Power Requirements:</b> 3.7 V YT562447 Lithium ion battery, installed functional, user replaceable. ( <b>Note:</b> Intended to be operated with power cables less than 3 m in length). (Wireless Only).
	<b>Maximum Wireless Distance:</b> 50' (15 m). (Wireless Only).
	<b>Handle Enclosure:</b> Thermoplastic elastomer over polycarbonate.
	<b>Supplied With:</b> Wrist strap.
	<b>Weight:</b> 13.6 oz (385 g).
	<b>Agency Approvals:</b> CE (not while charging), FCC compliant.

**FEATURES/BENEFITS**

- Allows for one handed operation for ladder use safety
- Stable 50 ft (15 m) wireless range

**APPLICATIONS**

- Building Commissioning
- Building HVAC test and balance

MODEL CHART	
Model	Description
VP2	Wireless 100 mm vane thermo-anemometer probe for use with the Model UHH handheld meter and the Mobile Meter® Software Test Instrument Mobile App



# THERMO-HYGROMETER

Measures % RH, Temperature, Dew Point and Wet Bulb

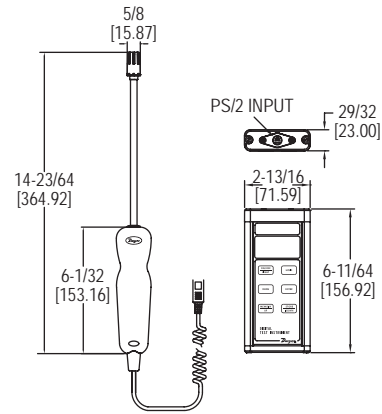

The **Model 485B Thermo-Hygrometer** is a versatile, compact, handheld instrument for measuring percentage of relative humidity and temperature in °F or °C. Dew point and wet bulb temperatures are derived from the relative humidity and temperature measurements and are displayed on the LCD.

**FEATURES/BENEFITS**

- Compatible with Dwyer AP1 thermo-anemometer and VP1 100 mm vane thermo-anemometer probes (sold separately)
- Hold feature to freeze current readings on the display
- Stores up to 99 readings for future evaluation

**APPLICATIONS**

- Building commissioning
- Pulp & paper

MODEL CHART	
Model	Description
485B-1	Digital thermo-hygrometer includes 9V battery, sensing probe, wrist strap, soft carrying case and instructions

OPTIONS	
Use order code:	Description
-NIST	NIST traceable calibration certificate

SPECIFICATIONS	
<b>Service:</b>	Humidity, temperature, wet bulb and dew point temperature detection in clean air.
<b>Temperature Limits:</b>	Process: -40 to 176°F (-40 to 80°C) Ambient: 5 to 125°F (-15 to 51°C).
<b>Range Relative Humidity:</b>	0 to 100% (non-condensing).
<b>Accuracy Relative Humidity:</b>	±2% FS over 10 to 90% @ 77°F (25°C).
<b>Range Temperature:</b>	-20 to 140°F (-28 to 60°C).
<b>Accuracy Temperature:</b>	±0.54°F @ 72°F (±0.3°C @ 25°C).
<b>Display:</b>	4.5 digit LCD.
<b>Resolution:</b>	0.1%, 0.1 °F/°C.
<b>Probe Length:</b>	8" (203 mm) insertion.
<b>Power Requirements:</b>	9 V alkaline battery, included, user replaceable.
<b>Weight:</b>	16 oz (454 g).
<b>Agency Approvals:</b>	CE.

ACCESSORIES	
Model	Description
RP1	Thermo-hygrometer % RH and temperature probe with coiled cable
UHH-C1	Soft carrying case
A-47X-BOOT	Protective magnetic rubber boot

**MODEL AQH-20**

# INDOOR AIR QUALITY METER

Measures CO<sub>2</sub>, Temperature and Humidity

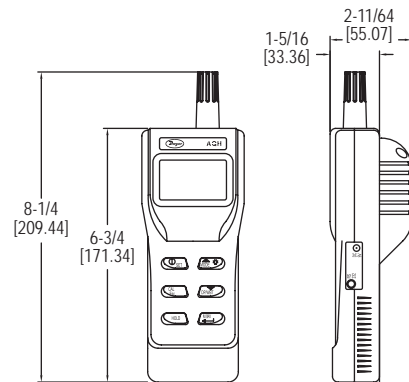

The **Model AQH-20 Handheld Indoor Air Quality Meter** reduces the number of instruments a contractor has to carry by measuring carbon dioxide concentration, air temperature, and humidity percentage in one device. A large backlit LCD shows all three parameters simultaneously. This product offers user selectable engineering units, maximum/minimum/average readings, a hold function, and an audible alarm.

**FEATURES/BENEFITS**

- All-in-one unit for carbon dioxide, temperature, and humidity
- Large backlit LCD for visibility in dark areas
- User configurable alarms for audible indication of hazardous conditions

**APPLICATIONS**

- Building commissioning
- Green house monitoring

MODEL CHART			
Model	CO <sub>2</sub> Range	Humidity Range	Temperature Range
AQH-20	0 to 2000 ppm	0.0 to 99.9%	14 to 140°F (-10 to 60°C)

SPECIFICATIONS	
<b>Ranges:</b>	CO <sub>2</sub> : 0 to 2000 ppm; Temperature: 14 to 140°F (-10 to 60°C); Relative Humidity: 0.0 to 99.9% RH.
<b>Accuracy:</b>	CO <sub>2</sub> : ±30 ppm ±5% of reading; Temperature: ±0.9°F (±0.6°C); Humidity: ±3% RH (10 to 90%), ±5% (0.0 to 9.9% or 90 to 99.9%).
<b>Resolution:</b>	CO <sub>2</sub> : 1 ppm; Temperature: 0.1°F (0.1°C); Humidity: 0.1% RH.
<b>Response Time:</b>	CO <sub>2</sub> : < 30 s; Temperature: < 2 minutes; Humidity: < 10 minutes.
<b>Display:</b>	4 digits for temperature/CO <sub>2</sub> and 3 digits for humidity.
<b>CO<sub>2</sub> Sensor:</b>	Non-dispersive infrared.
<b>Temperature Limits:</b>	32 to 122°F (0 to 50°C).
<b>Humidity Limits (Non-Condensing):</b>	0 to 95% RH.
<b>Power Requirements:</b>	(4) 1.5 V AA alkaline batteries, included, user replaceable.
<b>Warm Up Time:</b>	30 s.
<b>Weight:</b>	6.76 oz (200 g).

ACCESSORIES	
Model	Description
TH-CAL	33% and 75% salt bath calibration standards

**Dwyer**

MODEL 473B

# 100 MM VANE THERMO-ANEMOMETER TEST INSTRUMENT

Measures Air Velocity or Air Volume, Temperature, and Humidity Simultaneously

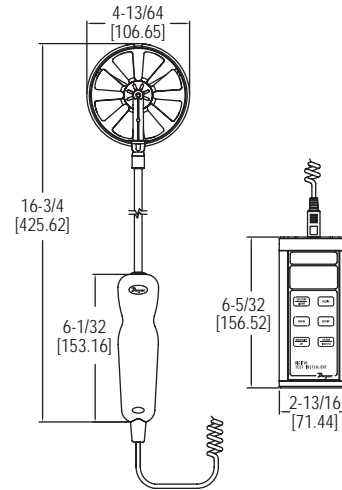

The **Model 473B 100 mm Vane Thermo-Anemometer Test Instrument** is a versatile unit that quickly and easily measures air velocity or volumetric air flow, as well as air temperature and humidity in imperial or metric units. A stainless steel 100 mm vane probe is included, which has a comfortable hand grip. The extruded aluminum housing fully protects electronics, yet is lightweight and comfortable to hold.

**FEATURES/BENEFITS**

- Compatible with Dwyer AP1 thermo-anemometer and RP1 thermo-hygrometer wired probes (sold separately)
- Included 100 mm vane probe is able to measure air velocity, volumetric air flow, temperature, and humidity
- High contrast and backlit LCD for visibility in any condition
- Able to store up to 99 readings for later evaluation

**APPLICATIONS**

- Residential balancing
- HVAC inspections

**MODEL CHART**

Model	Description
473B-1	Vane thermo-anemometer test instrument

**OPTIONS**

To order add suffix:	Description
-COC	Certificate of calibration
-FC	Factory calibration certificate
-NIST	NIST traceable calibration certificate

Example: 473B-1-NIST

**SPECIFICATIONS****Service:** Dry, clean air.**Temperature Limits:** Process: -20 to 212°F (-29 to 100°C); Ambient: 5 to 125°F (-15 to 51°C).**Display:** 4.5 digit backlit display.**Range:** Air velocity: 40 to 5000 fpm (0.2 to 25 m/s); Volumetric air flow: 19,999 in selected flow units; Temperature: -20 to 212°F (-29 to 100°C); Relative humidity: 0 to 100% RH.**Accuracy:** Air velocity: ±1.5% of reading ±20 fpm (±0.1 m/s) [0.25 to 10 m/s]; ±1.5% of reading ±40 fpm (±0.2 m/s) [10 to 20 m/s]; ±1.5% of reading ±60 fpm (±0.3 m/s) [20 to 25 m/s]; Temperature: ±0.54°F @ 77°F (±0.3°C @ 25°C); Relative Humidity: ±2% @ 77°F (25°C) [10 to 90% RH]; ±4% [0 to 10, 90 to 100% RH].**Response Time:** Air velocity: 1 s; Volumetric air flow: 1 s; Temperature: 1.5 s; Relative humidity: 1.5 s.**Probe Length:** 8" (203 mm) insertion.**Cable Length:** 28" (71 cm) retracted; 6' (18.3 m) extended.**Vane Material:** Anodized aluminum.**Power Requirements:** 9 V alkaline battery, installed non-functional, user replaceable.**Weight:** 18.4 oz (521 g).**ACCESSORIES**

Model	Description
A-47X-BOOT	Protective magnetic rubber boot
A-VPX-CKIT	Vane hood kit
AP1*	Hot wire thermo-anemometer probe with coiled cable
RP1*	Thermo-hygrometer probe with coiled cable
UHH-C1	Soft carrying case
VP1*	100 mm vane thermo-anemometer probe with coiled cable (replacement)

\*Consult website for more details.

A-47X-BOOT  
(manometer not included)

A-VPX-CKIT



AP1



RP1



UHH-C1



VP1

# THERMO-ANEMOMETER TEST INSTRUMENT

Measures Air Velocity or Air Volume and Temperature Simultaneously



**New six button operation provides quick access to enhanced features**

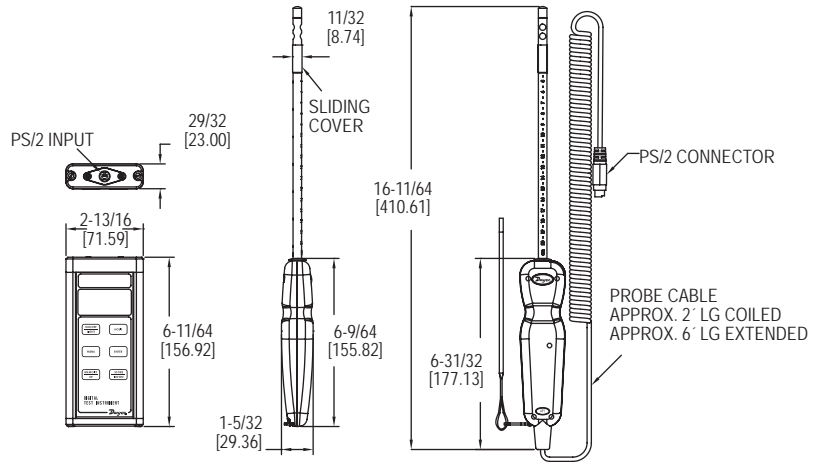

The **Model 471B Thermo-Anemometer Test Instrument** is a versatile dual function unit that quickly and easily measures air velocity or volumetric flow as well as air temperature in imperial or metric units. A stainless steel probe is included, which has a comfortable hand grip and etched insertion depth marks. The extruded aluminum housing fully protects electronics, yet is lightweight and comfortable to hold.

**FEATURES/BENEFITS**

- Compatible with Dwyer RP1 thermo-hygrometer and VP1 100 mm vane thermo-anemometer probes (sold separately)
- High contrast and backlit LCD for visibility in any condition
- Able to store up to 99 readings
- Integral sliding cover protects probe sensors when not in use
- Built-in volumetric air flow calculations

**APPLICATIONS**

- Duct traverses
- HVAC inspections
- Testing and balancing

MODEL CHART	
Model	Description
471B-1	Digital thermo anemometer includes 9V battery, sensing probe, wrist strap, soft carrying case and instructions

ACCESSORIES - CASES	
Model	Description
UHH-C1	Spare soft carrying case
A-160-CASE	Hard carrying case for longer probes (18" to 36")
A-47X-BOOT	Protective magnetic rubber boot

ACCESSORIES - PROBES		
Model	Probe Length	Description
AP1	8"	Thermo anemometer air velocity & temperature probe with coiled cable
AP1-18	18"	Thermo anemometer air velocity & temperature probe with coiled cable
AP1-24	24"	Thermo anemometer air velocity & temperature probe with coiled cable
AP1-36	36"	Thermo anemometer air velocity & temperature probe with coiled cable

**SPECIFICATIONS**

**Service:** Air velocity and temperature of clean, dry air.  
**Temperature Limits:** Process air velocity: -20 to 212°F (-29 to 100°C); Process temperature: -40 to 212°F (-40 to 100°C); Ambient: 5 to 125°F (-15 to 51°C).  
**Display:** 4.5 digit LCD.  
**Resolution:** 0.1%, 0.1 °F/°C.  
**Range Air Velocity:** 0 to 6000 FPM (0 to 30 m/s). -TAB option: 50 to 3900 FPM (0.25 to 20m/s).  
**Air Velocity Accuracy:** ±3% FS within temperature range of 40 to 90°F (4 to 32°C). -TAB option: ±5% of reading, not less than ±1.6 FPM (0.5 m).  
**Range Volumetric Air Flow:** 19,999 in selected flow units.  
**Range Temperature:** -40 to 212°F (-40 to 100°C).  
**Accuracy Temperature:** ±0.5°F (±0.28°C) from 32 to 122°F (0 to 50°C); ±1.5°F (±0.83°C) from -40 to 32°F (-40 to 0°C) & 122 to 212°F (50 to 100°C).  
**Probe Length:** 8" (203 mm) insertion.  
**Cable Length:** 28" (71 cm) retracted, 6 ft (183 cm) extended.  
**Power Requirements:** 9 V alkaline battery, installed non-functional, user replaceable.  
**Weight:** 16 oz (454 g).  
**Agency Approvals:** CE.



Replaceable probe with secure 6 pin adapter      Soft carrying case included with every unit      A-47X-BOOT (manometer not included)

OPTIONS	
Model	Description
-NIST	NIST traceable calibration certificate

# WIRELESS HYDRONIC DIFFERENTIAL PRESSURE MANOMETER

Liquid and Gas Pressure Measurement,  $\pm 2\%$  of Reading Accuracy

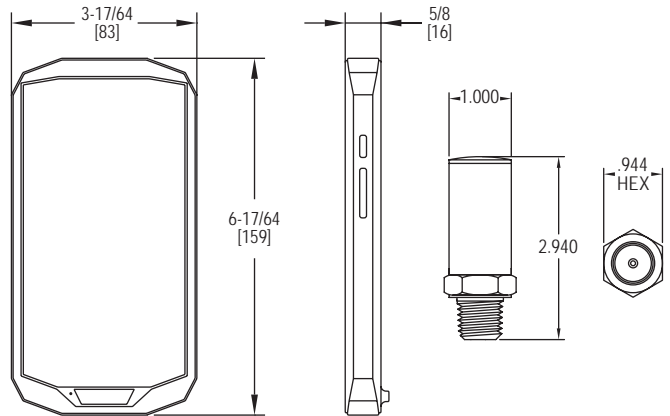

**Series 490W Wireless Hydronic Differential Pressure Manometer** is the most accurate and easy to operate manometer on the market. By using wireless transducers and a versatile handheld, a single operator can monitor and balance a hydronic system in less time than traditional hydronic balancers. The Series 490W utilizes mobile technology to communicate via a Bluetooth connection with the transducers to monitor differential pressure and flow on up to three different valves. Being wireless means there are no hoses to carry, snag on equipment or needing to be drained. The 490W includes the Dwyer Hydronic Application Software that contains valve charts for numerous manufacturers, which converts differential pressure to flow directly on the screen.

## FEATURES/BENEFITS

- Rugged weatherproof handheld housing withstands 1.5 meter drop test.
- Wireless measurement of differential pressure, single pressure and air flow.
- Share logged data directly from handheld over Wi-Fi, GSM or CDMA networks.
- Bluetooth direct wireless communication provides range up to 65 ft (19.8 m).
- The ergonomic design is much lighter and easier to work with, providing greater maneuverability and quick install setup.

## APPLICATIONS

- Refrigerant pressure testing
- Hydronic valve balancing
- Measure pressure drop across pumps
- Measure pressure drop across chiller and coils for freeze protection

## SPECIFICATIONS

**Wireless Distance:** Up to 65' (19.8 m).  
**Service:** Compatible gases & liquids.  
**Wetted Materials:** 316 SS, PTFE, brass.  
**Accuracy:** 2% of reading,  $\pm 1$  psi.  
**Compensated Temperature Range:** 14 to 140°F (-10 to 60°C).  
**Pressure Hysteresis:**  $\pm 0.25\%$  FS.  
**Pressure Range:** See chart.  
**Process Temperature Limits:** -4 to 185°F (-20 to 85°C).  
**Display:** 5" Gorilla® glass 3, touch screen, 1280x720.  
**Resolution:** 0.01 psi.  
**Power Connections:** Two 1/4" male NPT.  
**Power Requirements:** CR2050 or CR2032 lithium battery, user replaceable.  
**Weight:** 2 lb (907 g).  
**Agency Approvals:** CE, FCC.

## MODEL CHART

Model	English Range	Metric Range	Maximum Pressure	Available Engineering Units
<b>490W-6-HKIT</b>	0 to 50 psi, 0 to 200 psi	0 to 344.7 kPa, 0 to 1379 kPa	100 psi (6.89 bar), 400 psi (27.58 bar)	psi, ft w.c., in w.c., Pa, kPa, hPa, cm w.c., mm w.c.
<b>490W-6-HKIT-NIST</b>	0 to 50 psi, 0 to 200 psi	0 to 344.7 kPa, 0 to 1379 kPa	100 psi (6.89 bar), 400 psi (27.58 bar)	psi, ft w.c., in w.c., Pa, kPa, hPa, cm w.c., mm w.c.

## REPLACEMENT TRANSDUCERS

<b>A-490W-1</b>	0 to 15 psi	1.034 bar	30 psig	psi, ft w.c., in w.c., Pa, kPa, hPa, cm w.c., mm w.c.
<b>A-490W-2</b>	0 to 30 psi	2.069 bar	60 psig	psi, ft w.c., in w.c., Pa, kPa, hPa, cm w.c., mm w.c.
<b>A-490W-3</b>	0 to 50 psi	3.447 bar	100 psig	psi, ft w.c., in w.c., Pa, kPa, hPa, cm w.c., mm w.c.
<b>A-490W-4</b>	0 to 100 psi	6.895 bar	200 psig	psi, ft w.c., in w.c., Pa, kPa, hPa, cm w.c., mm w.c.
<b>A-490W-5</b>	0 to 500 psi	34.47 bar	1000 psig	psi, ft w.c., in w.c., Pa, kPa, hPa, cm w.c., mm w.c.
<b>A-490W-6</b>	0 to 200 psi	13.79 bar	400 psig	psi, ft w.c., in w.c., Pa, kPa, hPa, cm w.c., mm w.c.

## ACCESSORIES

Model	Description
<b>A-HKIT-500</b>	Piercing gage adapter, 1/8" dia x 1-1/2" length (2 per kit)
<b>A-HKIT-500XL</b>	Piercing gage adapter, 1/8" dia x 3" length (2 per kit)
<b>A-HKIT-510</b>	Piercing gage adapter, 1/16" dia x 1-1/2" length (2 per kit)

USA: California Proposition 65  
 ⚠ WARNING: Cancer and Reproductive Harm - www.P65Warnings.ca.gov

Gorilla® is a registered trademark of Corning, Incorporated



# HYDRONIC DIFFERENTIAL PRESSURE METER KIT

Liquid and Gas Pressure Measurement,  $\pm 0.5\%$  FS Accuracy



DEALER DESIGN AWARDS

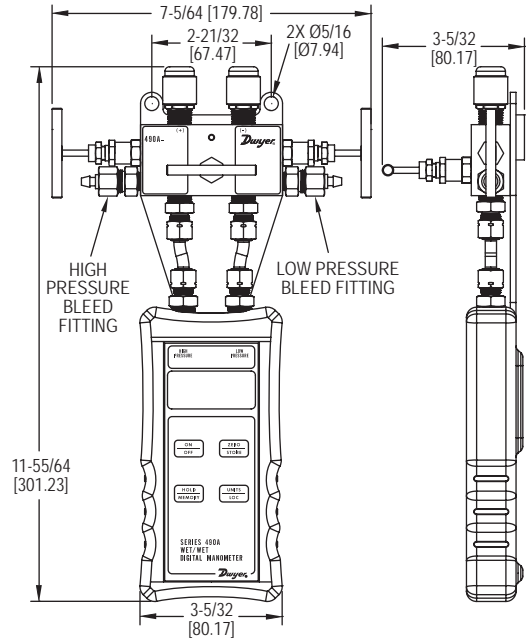

The **Series 490A-HKIT Hydronic Differential Pressure Meter Kit** features the 490A Hydronic Differential Pressure Manometer and all the necessary attachments and accessories to meet all your balancing, measuring, and pressure needs. The manometer featured in this kit is a versatile, handheld, battery operated manometer available in several ranges for positive or positive differential pressure measurement and can tolerate most liquid media compatible with 316L SS.

**FEATURES/BENEFITS**

- Digital dampening for low pressure stability
- Automatic resolution adjustment for finer control
- Hard carrying case protects products
- Stores up to 40 readings for later recall
- Backlight for use in dim areas
- Magnetic back mount for ease of use
- Rubber boot for easy handling and all day comfort

**APPLICATIONS**

- Chiller to coils for freeze protection
- Hydronic valve balancing
- Measure pressure drop across pumps
- Refrigerant pressure testing

**STANDARD KIT INCLUDES:**

- Two (2) 6ft high pressure rated tubing with shut off valves
- One (1) high pressure 3-way valve
- Two (2) controlled bleed valves
- One (1) 8 ft Poly tubing for purges
- One (1) hard traveling lockable case with non-absorbent foam
- One (1) handheld carrying strap
- Two (2) 1/16" x 1-1/2" pressure gage adapters
- Two (2) 1/8" x 3" pressure gage adapters
- Two (2) 1/8" x 1-1/2" pressure gage adapters
- Two (2) Male 90° Flare to 1/4" NPT fittings
- Two (2) Male Flare to 1/4" NPT coupler fittings
- One (1) adjustable 8" wrench
- PTFE Thread Tape
- One (1) magnetic protective rubber boot
- NIST Calibration Certificate Standard



**A-47X-BOOT**  
(manometer not included)

**SPECIFICATIONS**

<b>Service:</b> Compatible gases and liquids.	<b>Storage Temperature Limits:</b> -4 to 176°F (-20 to 80°C).
<b>Wetted Materials:</b> 316L SS, PTFE, Brass, Copper.	<b>Display:</b> 0.42" (10.6 mm) 4 digit LCD.
<b>Accuracy:</b> $\pm 0.5\%$ FS, 60 to 78°F (15.6 to 25.6°C); $\pm 1.5\%$ FS from 32 to 60°F and 78 to 104°F (0 to 15.6°C and 25.6 to 40°C).	<b>Resolution:</b> See chart.
<b>Pressure Hysteresis:</b> $\pm 0.1\%$ FS.	<b>Power Requirements:</b> 9 V alkaline battery, installed non-functional, user replaceable.
<b>Pressure Limits:</b> See chart.	<b>Weight:</b> 3.6 lb.
<b>Electronic Temperature Limits:</b> 32 to 140°F (0 to 60°C).	<b>Process Connections:</b> Two male 45 Flare 1/4".
<b>Process Temperature Limits:</b> -20 to 180°F.	<b>Agency Approvals:</b> CE.

**MODEL CHART**

Model	Range (psi)	Available Pressure Units & Resolution**								Maximum Pressure
		bar	psi	in Hg	kPa	in w.c.	mm Hg	mbar	ft w.c.	
490A-1-HKIT	0 to 15	1.034	15.00	30.54	103.4	415.2	775.7	1034	34.60	30 psig
490A-2-HKIT	0 to 30	2.069	30.00	61.08	206.9	830.4	1551	2069	69.20	60 psig
490A-3-HKIT	0 to 50	3.447	50.00	101.8	344.7	1384	2585	3447	115.3	100 psig
490A-4-HKIT	0 to 100	6.895	100.0	203.6	689.5	2768	5171	6895	230.7	200 psig
490A-5-HKIT	0 to 500	34.47	500.0	1018	3447	9999*	9999*	9999*	1153	1000 psig
490A-6-HKIT	0 to 200	13.79	200.0	407.2	1379	5536	9999*	9999*	461.3	400 psig

\*Digits will display smaller units until all 4 digits are exceeded.  
\*\*Readings less than 10% of range will provide one additional decimal place than shown for higher resolution.

**ACCESSORIES**

Model	Description
A-47X-BOOT	Rubber boot for manometers (manometer no included)
A-HKIT-AFIT	Adapter fitting kit for the 490A-HKIT, includes pairs of SAE 1/4" adapters and elbow fittings
A-HKIT-BFIT	Adapter fitting kit for the 490A-HKIT, includes pair of bleed fitting assemblies
A-HKIT-HOSES	One pair red & blue 60" SAE replacement hoses for the 490A-HKIT, each with integral ball valve
A-HKIT-500	Piercing gage adapter for the 490A-HKIT, 1/8" dia x 1-1/2" length (2 per kit)
A-HKIT-500XL	Piercing gage adapter for the 490A-HKIT, 1/8" dia x 3" length (2 per kit)
A-HKIT-510	Piercing gage adapter for the 490A-HKIT, 1/16" dia x 1-1/2" length (2 per kit)
NIST Calibration	Please contact your regional Dwyer distributor or Dwyer International Sales Office for scheduling your NIST recertification

USA: California Proposition 65  
⚠ WARNING: Cancer and Reproductive Harm - www.P65Warnings.ca.gov

# DIFFERENTIAL PRESSURE MODULES

Wireless, Measures Differential Pressure, Air Velocity, and Flow

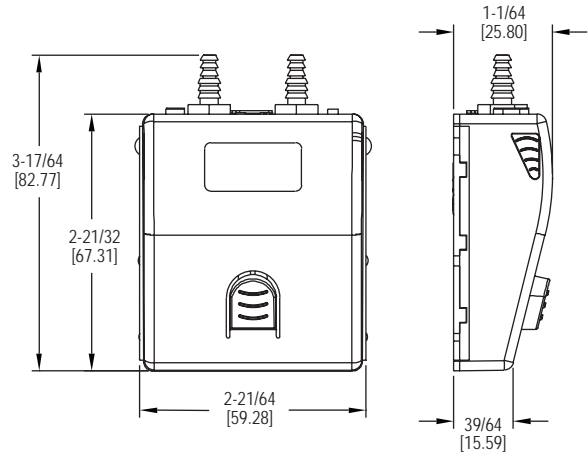

Series WDPM Wireless Differential Pressure Modules are used with the Model UHH handheld meter and the Mobile Meter® Software Test Instrument Mobile App.

**FEATURES/BENEFITS**

- Compatible with Dwyer's Mobile Meter App
- Bluetooth Gateway allows for up to 10 probes for simultaneous readings
- Simple single button operation for power and logging
- Wide selections of ranges for optimum accuracy
- Stable 50' (15 m) wireless range

**APPLICATIONS**

- Building commissioning
- Building HVAC test and balance
- Critical environment testing
- Industrial process verification
- Instrumentation validation

MODEL CHART		
Model	Range	Maximum Pressure
WDPM-002	±2 in w.c. (±500 Pa)	10 psi (68.9 kPa)
WDPM-005	±5 in w.c. (±1250 Pa)	10 psi (68.9 kPa)
WDPM-010	±10 in w.c. (±2.5 kPa)	10 psi (68.9 kPa)
WDPM-020	±20 in w.c. (±5 kPa)	20 psi (137.9 kPa)
WDPM-030	±30 in w.c. (±7.5 kPa)	20 psi (137.9 kPa)
WDPM-100	±100 in w.c. (±25 kPa)	15 psi (103.4 kPa)
WDPM-200	±200 in w.c. (±50 kPa)	45 psi (310.3 kPa)
WDPM-350	±350 in w.c. (±87 kPa)	45 psi (310.3 kPa)

**SPECIFICATIONS**

**Service:** Non-corrosive dry gases.  
**Wetted Materials:** Consult factory.  
**Accuracy:** ±0.5% FS span @ 25°C (includes non linearity, hysteresis, and non repeatability).  
**Pressure Limits:** See model chart.  
**Engineering Units:** Pressure: in w.c., ft w.c., in Hg, psi, OzSl, mm w.c., cm w.c., mBar, Pa, hPa, and kPa; Velocity: fpm, mph, kn, m/s, m/h, k/h, and fps; Flow: cfm, gpm, gph, gpd, m³/h, m³/h, lps, lpm, and lph.  
**Temperature Limits:** Compensated: 32 to 140°F (0 to 60°C); Process/ambient: 14 to 140°F (-10 to 60°C).  
**Thermal Effects:** ±0.01% FS/°F (±0.02% FS/°C).  
**Battery Charging Limits:** 32 to 113°F (0 to 45°C).  
**Power Requirements:** 3.7 V YT562447 lithium ion battery, installed functionally, user replaceable.  
**Wireless Distance:** At least 50' (15 m).  
**Connections:** Two barbed connections for use with 1/8" (3.18 mm) or 3/16" (4.76 mm) ID tubing.  
**Weight:** 2.5 oz (70.87 g).  
**Agency Approvals:** CE with CE approved charger, FCC.

**ACCESSORIES**

Model	Description
A-WDPM-BRK	Differential pressure mounting bracket

## SERIES UHH-ACC HANDHELD ACCESSORIES



**UHH-C1**  
soft carrying case  
(19" x 6" x 3")



**KF-CC-304**  
dual USB charger



**A-VPX-CKIT**



**UHH-C2**  
hard carrying case  
(24" x 18" x 9")

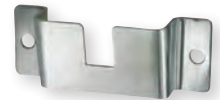

**A-WDPM-BRK**  
differential pressure  
mounting bracket

**FEATURES/BENEFITS**

- Rugged weatherproof housing withstands 1.5 meter drop test
- Wireless measurement of pressure, air velocity, air flow, temperature, and humidity
- Share logged data directly from handheld over Wi-Fi, GSM or CDMA networks
- Multitude of case options for full field service

**APPLICATIONS**

- Building commissioning
- Building HVAC test and balance
- Critical environment testing
- Industrial process verification
- Instrumentation validation

**ACCESSORIES**

Model	Description
UHH-ICHRG	UHH dual USB charger with international adapters (1.0 A) (Not CE approved)
UHH-CBL	USB cable
UHH-CBL2	USB to micro-USB cable
UHH-C1	Soft carrying case
UHH-SD	2 GB SD card
KF-CC-304	Dual USB charger with North American adapter (1.5 A)
UHH-C2	Heavy duty hard case with pre-cut foam inserts for additional sensors
A-VPX-CKIT	Vane hood kit
A-WDPM-BRK	Differential pressure mounting bracket

# HANDHELD DIGITAL MANOMETER

Measures Pressure, Flow and Velocity;  $\pm 0.5\%$  Accuracy

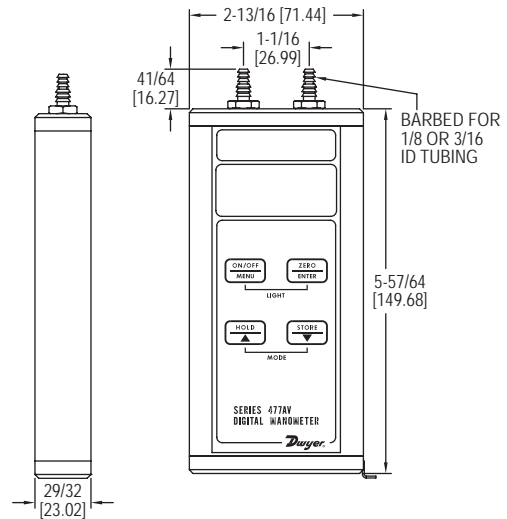

The **Series 477AV Handheld Digital Manometer** is now available with pressure, flow, and velocity measurements along with a number of other convenient features. The built-in air velocity and flow calculations provide accuracy and conserve time and error associated with manual calculations. Also featured on this unit are adjustable zero and span values for calibrating in the field, as well as a damping feature to compensate for the fluctuating of readings.

**FEATURES/BENEFITS**

- Calculates and displays air velocity and volumetric air flow
- Rugged aluminum case protects instrument from damage during transport/use
- 9 selectable English and metric engineering units
- Large, easy to read display with backlight for use in dark areas
- Stores up to 40 readings with minimum, maximum and average statistics

**APPLICATIONS**

- Air flow monitoring
- Duct static pressure

**SPECIFICATIONS**

**Service:** Air and compatible gases.  
**Wetted Materials:** Consult factory.  
**Accuracy:**  $\pm 0.5\%$  FS, 60 to 78°F (15.6 to 25.6°C);  $\pm 1.5\%$  FS from 32 to 60°F and 78 to 104°F (0 to 15.6°C and 25.6 to 40.0°C).  
**Pressure Hysteresis:**  $\pm 0.1\%$  FS.  
**Pressure Limits:** See chart.  
**Temperature Limits:** 0 to 140°F (-17.8 to 60°C).  
**Compensated Temperature Limits:** 32 to 104°F (0 to 40°C).  
**Storage Temperature Limits:** -4 to 176°F (-20 to 80°C).  
**Display:** 0.42" (10.6 mm) 4 digit LCD.  
**Resolution:** See chart.

**Units of Pressure:** in w.c., ft w.c., in Hg, psi, oz/in<sup>2</sup>, mm w.c., cm w.c., mm Hg, mbar, Pa, kPa, hPa.  
**Units of Velocity:** fpm, fps, mph, m/h, m/s, k/h, knot.  
**Units of Flow:** cfm, m<sup>3</sup>/h, m<sup>3</sup>/s.  
**Power Requirements:** 9 V alkaline battery, installed non-functional, user replaceable.  
**Weight:** 10.2 oz (289 g).  
**Process Connections:** Two barbed connections for use with 1/8" (3.18 mm) or 3/16" (4.76 mm) ID tubing. Two compression fittings for use with 1/8" (3.18 mm) ID x 1/4" (6.35 mm) OD tubing for 477AV-7 and 477AV-8 only.  
**Agency Approvals:** CE.

**MODEL CHART**

Model	Pressure Range	Velocity Range		Available Pressure Units												Maximum Pressure
		fpm	m/s	psi	in Hg	kPa	in w.c.	mm Hg	mbar	mm w.c.	Pa	ft w.c.	oz/in <sup>2</sup>	hPa	cm w.c.	
477AV-000	0 to 1.000 in w.c.	4004	20.34	-	0.0736	0.2491	1.000	1.868	2.491	25.40	249.1	0.0833	0.5780	2.491	2.540	5 psig
477AV-00	0 to 4.000 in w.c.	8009	40.69	0.1445	0.2942	0.996	4.000	7.473	9.96	101.6	996	0.3333	2.312	9.964	10.16	5 psig
477AV-0	0 to 10.00 in w.c.	1.266k	64.33	0.3613	0.7355	2.491	10.00	18.68	24.91	254.0	2491	0.8333	5.780	24.91	25.40	5 psig
477AV-1	0 to 20.00 in w.c.	1.791k	90.97	0.7225	1.471	4.982	20.00	37.36	49.82	508.0	4982	1.667	11.56	49.82	50.80	10 psig
477AV-2	0 to 40.00 in w.c.	25.33k	128.7	1.445	2.942	9.96	40.00	74.73	99.6	1016	9964	3.333	23.12	99.64	101.6	10 psig
477AV-3	0 to 200.0 in w.c.	56.63k	287.7	7.225	14.71	49.82	200.0	373.6	498.2	5080	-	16.67	115.6	498.2	508.0	30 psig
477AV-4	0 to 10.00 psi	66.62k	338.4	10.00	20.36	68.95	276.8	517.1	689.5	7031	-	13.07	160.0	689.5	703.1	30 psig
477AV-5	0 to 20.00 psi	94.22k	478.6	20.00	40.72	137.9	553.6	1034	1379	-	-	46.13	320.0	1379	1406	60 psig
477AV-6	0 to 30.00 psi	115.4k	586.2	30.00	61.08	206.9	830.4	1551	2069	-	-	69.20	480.0	2068	2109	60 psig
477AV-7	0 to 100.0 psi	210.7k	1070	100.0	203.6	689.5	2768	5171	6895	-	-	230.7	1600	6895	7031	150 psig
477AV-8	0 to 150.0 psi	258.0k	1311	150.0	305.4	1034	4152	7757	-	-	-	346.0	2400	-	-	200 psig

**OPTIONS**

To order add suffix:	Description
-NIST	NIST traceable calibration certificate
Example: 477AV-1-NIST	

**ACCESSORIES**

Model	Description
A-402A	Carrying case; tough gray nylon pouch protects any Series 477AV Manometer; double zippered for quick and easy access, with a belt loop that snaps closed; 7-1/2"H x 3"W x 2-1/4"D (191 x 76 x 57 mm)
UHH-C1	Soft carrying case
A-47X-BOOT	Protective magnetic rubber boot



A-402A



UHH-C1



A-47X-BOOT  
(manometer not included)

# INTRINSICALLY SAFE HANDHELD DIGITAL MANOMETER

Ranges from 1 in w.c. to 150 psid,  $\pm 0.5\%$  Accuracy

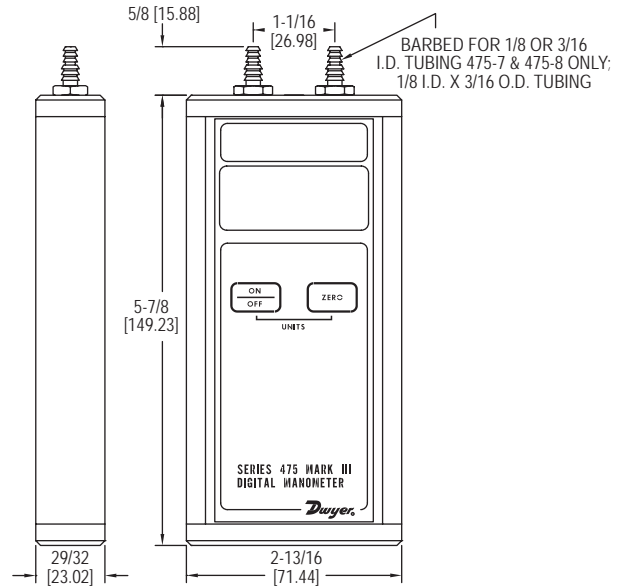

The **Series 475 Intrinsically Safe Handheld Digital Manometer** measures positive, negative, or differential pressures of air and natural gases in ranges from 1 in w.c. (0.249 kPa) to 150 psid (10.34 bar). The dual push pads on the front panel control the on/off, auto zero, and pressure unit selection, allowing for simple operation with no set up needed. When used with a Dwyer® Pitot tube (●), the Series 475 can also be used as an air velocity gage.

**FEATURES/BENEFITS**

- Rugged aluminum case protects instrument from damage during transport/use
- Large, easy to read LCD and simple operation
- FM approved to be intrinsically safe in hazardous locations, Class 1, Div 2, Groups A, B, C, D, T4 Ta = 70°C

**APPLICATIONS**

- Monitoring natural gas pressures on boilers and other combustion equipment
- Air velocity monitoring, when used with a Dwyer® Pitot tube (●) and AV calculator
- Field calibration of other instruments
- Monitoring or troubleshooting HVAC systems

**SPECIFICATIONS**

**Service:** Air and compatible combustible gases.  
**Wetted Materials:** Consult factory.  
**Accuracy:**  $\pm 0.5\%$  FS, 60 to 78°F (15.6 to 25.6°C);  $\pm 1.5\%$  FS from 32 to 60°F and 78 to 104°F (0 to 15.6°C and 25.6 to 40°C).  
**Pressure Hysteresis:**  $\pm 0.1\%$  FS.  
**Pressure Limits:** See chart.  
**Temperature Limits:** 0 to 140°F (-17.8 to 60°C).  
**Compensated Temperature Limits:** 32 to 104°F (0 to 40°C).  
**Storage Temperature Limits:** -4 to 176°F (-20 to 80°C).  
**Display:** 0.42" (10.6 mm) 4 digit LCD.  
**Resolution:** See chart.  
**Power Requirements:** 9 V alkaline battery, installed non-functional, user replaceable.  
**Weight:** 10.8 oz (306 g).  
**Process Connections:** Two barbed connections for use with 1/8" (3.18 mm) or 3/16" (4.76 mm) ID tubing. Two compression fittings for use with 1/8" (3.18 mm) ID x 1/4" (6.35 mm) OD tubing for 475-7 & 475-8 only.  
**Agency Approvals:** CE, FM approved to Class I, Div 2, Groups A, B, C, D, T4 Ta = 70°C.

MODEL CHART			
Model	English Range	Metric Range	Maximum Pressure
475-000-FM	0 to 1.000 in w.c.	.2491 kPa	5 psig
475-00-FM	0 to 4.000 in w.c.	0.996 kPa	5 psig
475-0-FM	0 to 10.00 in w.c.	2.491 kPa	5 psig
475-1-FM	0 to 20.00 in w.c.	4.982 kPa	10 psig
475-2-FM	0 to 40.00 in w.c.	9.96 kPa	10 psig
475-3-FM	0 to 200.0 in w.c.	49.82 kPa	30 psig
475-4-FM	0 to 10.00 psi	.6895 bar	30 psig
475-5-FM	0 to 20.00 psi	1.379 bar	60 psig
475-6-FM	0 to 30.00 psi	2.069 bar	60 psig
475-7-FM	0 to 100.0 psi	6.895 bar	150 psig
475-8-FM	0 to 150.0 psi	10.34 bar	200 psig

ACCESSORIES	
Model	Description
A-402A	Carrying case, tough gray nylon pouch protects any Series 475 manometer, double zippered for quick and easy access, belt loop that snaps closed, 7-1/2"H x 3"W x 2-1/4"D (191 x 76 x 57 mm)
UHH-C1	Soft carrying case
A-47X-BOOT	Protective magnetic rubber boot

OPTIONS	
To order add suffix:	Description
-AV	Air velocity kit, includes the Series 475 manometer, two A-303 static pressure tips two 9' lengths 3/16" ID rubber tubing, no. 166-6-CF pitot tube, A-397 step drill, A-532 air velocity slide chart and instruction bulletin H-11, all packed in a tough, molded plastic carrying case with die cut foam liner.
<b>Examples:</b>	475-1-AV; 475-000-AV
-NIST	NIST traceable calibration certificate
<b>Example:</b>	475-1-NIST



● Pitot tube: See pages 205-234 (Air Quality section)  
 Process Tubing Options: See page 455 (Gage Tubing Accessories)

Manometers, Portable



# AIR VELOCITY KITS

Digital Manometer and Pitot Tube for Balancing System Air Flows



475-XX-FM-AV



475-XXT-FM-AV



477-XXXT-AV

Convenient all-in-one **Series 475-AV & 477-AV Air Velocity Kits** are small, light and easy to use. No set-up or leveling needed. An indispensable test kit for the plant engineer, and HVAC technician that must balance system air flows at start-up.

**FEATURES/BENEFITS**

- Comprehensive kit for HVAC and industrial applications
- Rugged construction for longevity
- Conversion from pressure to air velocity made easy
- Proudly assembled in the USA

**APPLICATIONS**

- Building commissioning
- Building HVAC test and balance
- Critical environment testing
- Industrial process verification
- Instrumentation validation

**MODEL CHART - 475-XX-FM-AV**

Model	Range
475-00-FM-AV	0-4.000 in w.c.
475-0-FM-AV	0-10.00 in w.c.
475-1-FM-AV	0-20.00 in w.c.
475-2-FM-AV	0-40.00 in w.c.

**THE SERIES 475-XX-FM-AV KIT INCLUDES:**

- Series 475 digital manometer (±0.5% FS accuracy and minor divisions to 0.01, large 1/2" LCD readout is easy to see in poorly lighted areas and has "low battery" warning)
- Model 166-6-CF, 6" SS pitot tube with integral compression fitting to hold it securely when taking readings
- Two no. A-303 static pressure tips with magnetic mounting
- Two 9' lengths 3/16" ID rubber tubing
- No. A-397 step drill for 3/16"-1/2" holes in 1/16" increments
- No. A-532 AV slide chart
- 9 V battery
- Fitted polyethylene case

**MODEL CHART - 475-XXT-FM-AV**

Model	Range
475-00T-FM-AV	0-4.000 in w.c.
475-0T-FM-AV	0-10.00 in w.c.
475-1T-FM-AV	0-20.00 in w.c.

**THE SERIES 475-XXT-FM-AV KIT INCLUDES:**

- Series 475 digital manometer (±0.5% FS accuracy and minor divisions to 0.01, large 1/2" LCD readout is easy to see in poorly lighted areas and has "low battery" warning)
- Model 166T, 36" telescoping SS pitot tube, fully adjustable from 11.5" to 36" (29.2 to 91.4 cm)
- Two no. A-303 static pressure tips with magnetic mounting
- Two 4-1/2' L 3/16" ID rubber tubing
- No. A-397 step drill for 3/16"-1/2" holes in 1/16" increments
- No. A-532 AV slide chart
- 9 V alkaline battery
- Fitted polyethylene case

**MODEL CHART - 477AV-XXXT-AV**

Model	Range
477-000T-AV	0-1.000 in w.c.
477-00T-AV	0-4.000 in w.c.
477-0T-AV	0-10.00 in w.c.
477-1T-AV	0-20.00 in w.c.

**THE SERIES 477-XXXT-AV KIT INCLUDES:**

- Series 477AV digital manometer (±0.5% FS accuracy, calculates air velocity or volumetric air flow, stores up to 40 readings in memory, instantly selecting up to nine English/Metric pressure units, large, backlit 0.4" LCD readout, both audible and visual overpressure alarms and a "low battery" warning are standard features)
- Model 166T, 36" telescoping SS pitot tube, fully adjustable from 11.5" to 36" (29.2 to 91.4 cm)
- Two no. A-303 static pressure tips with magnetic mounting
- Two 4-1/2' L 3/16" ID rubber tubing
- No. A-397 step drill for 3/16"-1/2" holes in 1/16" increments
- No. A-532 AV slide chart
- 9 V alkaline battery
- Fitted polyethylene case

# SINGLE PRESSURE DIFFERENTIAL PRESSURE DIGITAL MANOMETERS

Electronic Zeroing,  $\pm 1.5\%$  Accuracy

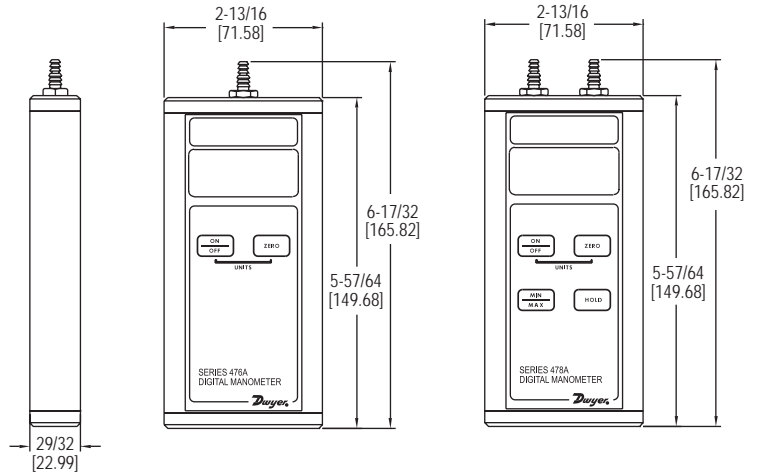

The **Series 476A Single Pressure Differential Pressure Digital Manometer** can be used to measure low pressures from -20 to 20 in w.c. with  $\pm 1.5\%$  FS accuracy. The **Series 478A Single Pressure Differential Pressure Digital Manometer** can be used to measure positive, negative, or differential pressures. Both units are constructed of an extruded aluminum case for exceptional durability.

#### FEATURES/BENEFITS

- $\pm 0.5\%$  FS accuracy
- Rugged extruded aluminum housing
- One button auto-zero function
- Auto power off function to conserve battery life
- Instant selection of up to nine English/metric units

#### APPLICATIONS

- Verify field instrumentation performance
- Adjust fuel mixture on combustion systems

#### SPECIFICATIONS

**Service:** Air and compatible gases.  
**Wetted Materials:** Consult factory.  
**Accuracy:**  $\pm 1.5\%$  FS at 72°F (22.2°C). Includes linearity and repeatability.  
**Pressure Hysteresis:**  $\pm 0.1\%$  FS.  
**Pressure Limits:** 5 psig (.74 bar).  
**Temperature Limits:** 0 to 140°F (-17.8 to 60°C).  
**Compensated Temperature Limits:** 32 to 104°F (0 to 40°C).  
**Thermal Effect:** 0.05% FS/°F.  
**Display:** 4 digit LCD (.425"H x .234"W digits).  
**Power Requirements:** 9 V alkaline battery, installed non-functional, user replaceable.  
**Process Connections:** For use with 3/16" or 1/4" ID tubing.  
**Weight:** 10.8 oz (306 g).  
**Agency Approvals:** CE.

#### MODEL CHART

Model	Range in w.c.	Available Pressure Units								Resolution in w.c.	Maximum Pressure	
		bar	psi	in Hg	kPa	in w.c.	mm Hg	mbar	mm w.c.			Pa
476A-0	-20.0 to 20.0	.0498	0.723	1.471	4.98	20.00	37.4	49.8	508	-	0.02	5 psig
478A-0	-4.00 to 4.00	-	.1445	.294	0.996	4.00	7.47	9.96	101.6	996	0.01	5 psig
478A-1	-60.0 to 60.0	.1495	2.168	4.41	14.95	60.0	112.1	149.5	1524	-	0.1	5 psig

#### OPTIONS

To order add suffix:	Description
-NIST	NIST traceable calibration certificate
Example: 478A-1-NIST	

#### ACCESSORIES

Model	Description
A-402A	Carrying case, tough gray nylon pouch protects any Series 476A/478A manometer, double zippered for quick and easy access, belt loop that snaps closed, 7-1/2"H x 3"W x 2-1/4"D (191 x 76 x 57 mm)
UHH-C1	Soft carrying case
A-47X-BOOT	Protective magnetic rubber boot



A-402A



UHH-C1

A-47X-BOOT  
(manometer not included)

# HANDHELD DIGITAL MANOMETER

Precise Air Pressure Measurement,  $\pm 0.1\%$  Accuracy

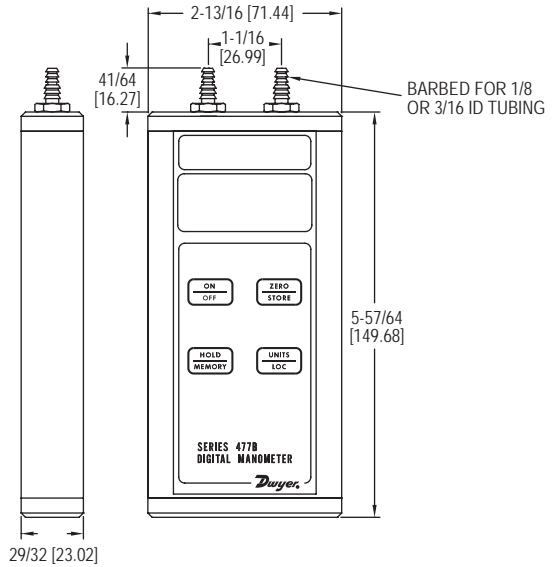

The **Series 477B Handheld Digital Manometer** is a versatile, hand-held, battery operated manometer available in several basic ranges from 0-20 in w.c. up to 100 psi. All models measure either positive, negative or differential pressures with  $\pm 0.10\%$  of full-scale accuracy. You can select from up to seven common English and metric pressure units so conversions are not necessary. A memory function allows storage of up to 40 readings for later recall and a backlight provides auxiliary lighting for hard-to-see locations. Also standard are a hold feature plus both visual and audible overpressure alarms.

**FEATURES/BENEFITS**

- Precise 0.1% FS accuracy provides four times better accuracy than most standard manometer/gages
- Aluminum housing protects instrument against damage
- 40 readings in internal memory reduces time to record data

**APPLICATIONS**

- Lab calibration of other pressure instruments
- Air velocity/air flow measurements in commercial buildings

**SPECIFICATIONS**

**Service:** Air and compatible gases.  
**Wetted Parts:** Consult factory.  
**Accuracy:**  $\pm 0.10\%$  FS from 60 to 78°F (15.6 to 25.6°C);  $\pm 1\%$  FS from 32 to 60 and 78 to 104°F (0 to 15.6 and 25.6 to 40°C).  
**Pressure Hysteresis:**  $\pm 0.1\%$  FS.  
**Pressure Limits:** See chart.  
**Temperature Limits:** 0 to 140°F (-17.8 to 60°C).  
**Storage Temperature Limits:** -4 to 176°F (-20 to 80°C).  
**Display:** 4-digit LCD (.425" H x .234" W digits).  
**Resolution:** See chart.  
**Power Requirements:** 9 volt alkaline battery. Battery included but not connected.  
**Connections:** Two barbed connections for use with 1/8" (3.18 mm) or 3/16" (4.76 mm) I.D. tubing for 477B-1, 477B-2, 477B-3, 477B-4 and 477B-5 only. Two compression fittings for use with 1/8" (3.18 mm) I.D. x 1/4" (6.35 mm) O.D. tubing for 477B-6 and 477B-7 only.  
**Weight:** 10.2 oz. (289 g).  
**Agency Approvals:** CE.

MODEL CHART												
Model	Range	Available Pressure Units										Maximum Pressure
		bar	psi	in Hg	kPa	in w.c.	mm Hg	mbar	ft w.c.	mm w.c.	Pa	
477B-1	0 to 20.00 in w.c.	.0498	.7225	1.471	4.982	20.00	37.36	49.82	1.667	508.0	4982	3 psig
477B-2	0 to 40.00 in w.c.	.0996	1.445	2.942	9.96	40.00	74.73	99.6	3.333	1016	9964	3 psig
477B-3	0 to 200.0 in w.c.	.4982	7.225	14.71	49.82	200.0	373.6	498.2	16.67	5080	-	15 psig
477B-4	0 to 10.00 psi	.6895	10.00	20.36	68.95	276.8	517.1	689.5	23.07	7031	-	30 psig
477B-5	0 to 30.00 psi	2.069	30.00	61.08	206.9	830.4	1551	2069	69.20	-	-	60 psig
477B-6	0 to 50.00 psi	3.447	50.00	101.8	344.7	1384	2585	3447	115.3	-	-	100 psig
477B-7	0 to 100.0 psi	6.895	100.0	203.6	689.5	2768	5171	6895	230.7	-	-	200 psig

OPTIONS	
To order add suffix:	Description
-NIST	NIST traceable calibration certificate
Example: 477B-1-NIST	

ACCESSORIES	
Model	Description
A-402A	Carrying case; tough gray nylon pouch protects any Series 477B Manometer; double zippered for quick and easy access, with a belt loop that snaps closed; 7-1/2"H x 3"W x 2-1/4"D (191 x 76 x 57 mm)
UHH-C1	Soft carrying case
A-47X-BOOT	Protective magnetic rubber boot



A-402A



UHH-C1



A-47X-BOOT  
(manometer not included)

# HYDRONIC DIFFERENTIAL PRESSURE MANOMETER

Liquid and Gas Pressure Measurement,  $\pm 0.5\%$  FS Accuracy

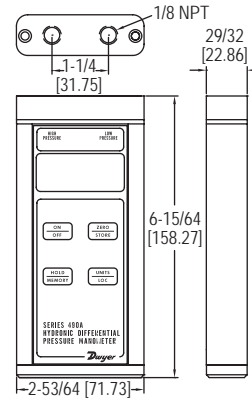

The **Series 490A Hydronic Differential Pressure Manometer** is versatile, hand-held, battery operated manometers available in several basic ranges for positive or positive differential pressure measurement and can tolerate most liquid media compatible with 316L SS.

A new feature added to the Series 490A is a field adjustable damping, which allows the user to choose the level of display averaging rate corresponding to the fluctuation level common in many applications.

**FEATURES/BENEFITS**

- Seven user-selectable English and metric units
- Stores up to 40 readings for later recall
- Backlight for use in dim areas
- Digital dampening for low pressure - high resolution logging stability
- Automatic resolution adjustment for finer control

**APPLICATIONS**

- Chiller to coils for freeze protection
- Hydronic valve balancing
- Measure pressure drop across pumps
- Refrigerant pressure testing

**SPECIFICATIONS**

**Service:** Compatible gases and liquids.  
**Wetted Materials:** Without valve: 316L SS, -3V option: 316L SS, Buna-N, silicone, grease, PTFE, brass 360, copper, reinforced acetel copolymer.  
**Accuracy:**  $\pm 0.5\%$  FS, 60 to 78°F (15.6 to 25.6°C);  $\pm 1.5\%$  FS from 32 to 60°F and 78 to 104°F (0 to 15.6°C and 25.6 to 40°C).  
**Pressure Hysteresis:**  $\pm 0.1\%$  FS.  
**Pressure Limits:** See chart.  
**Electronic Temperature Limits:** 32 to 140°F (0 to 60°C).  
**Storage Temperature Limits:** -4 to 176°F (-20 to 80°C).  
**Display:** 0.42" (10.6 mm) 4 digit LCD.  
**Resolution:** See chart.  
**Power Requirements:** 9 V alkaline battery, installed non-functional, user replaceable.  
**Weight:** 14.1 oz (400 g).  
**Process Connections:** Two 1/8" (3.18 mm) female NPT.  
**Agency Approvals:** CE.

**MODEL CHART**

Model	Range psi	Available Pressure Units & Resolution**								Maximum Pressure
		bar	psi	in Hg	kPa	in w.c.	mm Hg	mbar	ft w.c.	
490A-1	0 to 15.00	1.034	15.00	30.54	103.4	415.2	775.7	1034	34.60	30 psig
490A-2	0 to 30.00	2.069	30.00	61.08	206.9	830.4	1551	2069	69.20	60 psig
490A-3	0 to 50.00	3.447	50.00	101.8	344.7	1384	2585	3447	115.3	100 psig
490A-4	0 to 100.0	6.895	100.0	203.6	689.5	2768	5171	6895	230.7	200 psig
490A-5	0 to 500.0	34.47	500.0	1018	3447	9999*	9999*	9999*	1153	1000 psig
490A-6	0 to 200.0	13.79	200.0	407.2	1379	5536	9999*	9999*	461.3	400 psig

\*Digits will display smaller units until all 4 digits are exceeded.  
 \*\*Readings less than 10% of range will provide one additional decimal place than shown for higher resolution.

**OPTIONS**

To order add suffix:	Description
-NIST	Includes NIST Calibration traceable certificate
<b>Example:</b> 490A-1-NIST	
-3V	3-way vent valve with bleed screw rated up to 100 psi
<b>Example:</b> 490A-1-3V	



-3V option  
3-way vent valve

**ACCESSORIES**

Model	Description
A-47X-BOOT A-402A	Rubber boot for manometers (manometer no included) Carrying case, tough gray nylon pouch protects any Series 490A manometer, double zippered for quick and easy access, belt loop that snaps closed
A-HKIT-HOSES	One pair red & blue 60" SAE replacement hoses for the 490A-HKIT, each with integral ball valve
A-HKIT-500	Piercing gage adapter for the 490A-HKIT, 1/8" dia x 1-1/2" length (2 per kit)
A-HKIT-500XL	Piercing gage adapter for the 490A-HKIT, 1/8" dia x 3" length (2 per kit)
A-HKIT-510	Piercing gage adapter for the 490A-HKIT, 1/16" dia x 1-1/2" length (2 per kit)
NIST Calibration	Please contact your regional Dwyer distributor or Dwyer International Sales Office for scheduling your NIST recertification



A-47X-BOOT  
(manometer not included)



A-402A

USA: California Proposition 65  
 ⚠WARNING: Cancer and Reproductive Harm - www.P65Warnings.ca.gov



# PRECISION DIGITAL PRESSURE MANOMETER

Up to 0.05% Accuracy, Graphical Display, Data Logging Capability

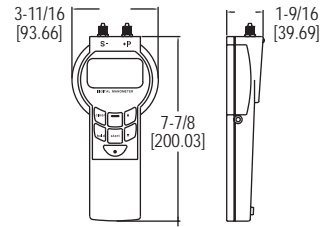

The **Series HM35 Precision Digital Pressure Manometer** is designed to reliably measure and log absolute pressure, differential pressure, or gage pressure with up to 0.05% accuracy. The data logging function can store up to 10,742 readings and transmit the readings to a PC through an IR serial port. The large display can graphically display trends in the data as well as peaks and valleys.

**FEATURES/BENEFITS**

- Able to record up to 10,742 readings, which can be downloaded to a PC
- Up to 0.05% accuracy for use in critical applications
- Measure absolute, differential, or gage pressure

**APPLICATIONS**

- Calibration facilities
- Laboratories

MODEL CHART - ERROR LIMIT 0.2% FS FOR GAGE, VACUUM, AND DIFFERENTIAL PRESSURE		
Model	Range	Over Pressure
HM3531DLB300	0 to 10 in w.c. (0-2.5 kPa)	50 in w.c.
HM3531DLC300	0 to 28 in w.c. (0-7 kPa)	140 in w.c.
HM3531DLE300	0 to 80 in w.c. (0-20 kPa)	600 in w.c.
HM3531DLF300	0 to 120 in w.c. (0-30 kPa)	600 in w.c.
HM3531DLG300	0 to 200 in w.c. (0-50 kPa)	58 psi
HM3531DLH300	0 to 14.5 psi (0-100 kPa)	58 psi

**Note:** For higher accuracy models, change the 10th digit from a 3 to a 1 (0.05% FS), 2 (0.1% FS), or 6 (0.1% of reading); higher accuracies are only available on 0 to 28 in of w.c. range or higher.

**Example:** HM3531DLC100 (0 to 28 in w.c. with 0.05% accuracy); consult factory.

**SPECIFICATIONS**

**Service:** Air and compatible gases.  
**Wetted Materials:** 18/8 stainless steel.  
**Accuracy:** (Includes linearity, hysteresis, and repeatability): Depending on model;  $\pm 0.20\%$  FS  $\pm 1$  digit;  $\pm 0.10\%$  FS  $\pm 1$  digit;  $\pm 0.05\%$  FS  $\pm 1$  digit.  
**Temperature Limits:** 32 to 122°F (0 to 50°C).  
**Storage Temperature:** -4 to 140°F (-20 to 60°C).  
**Humidity:** Maximum 95% RH non-condensing.  
**Display:** Graphical back lit LCD. 128 x 64 points.

**Power Requirements:** (3) 1.5 V AA alkaline batteries, installed functional, user replaceable. Can operate on 6 to 9 VDC external power.  
**Current Consumption:** 25 mA without back lit display, IR, or buzzer.  
**Memory:** 10,742 readings. Recording intervals adjustable from 1 s to 24 hrs or manual.  
**Case Protection:** IP54 (NEMA 3).  
**Weight:** 10.5 oz (300 g).  
**Process Connections:** Hose 4/6 mm or 1/8" NPT.

**ACCESSORIES**

Model	Description
HM28-0	1/8" NPT adapter (1 piece)
HM35-1	Communication software key
HM35-2	Infrared RS-232 serial adapter, required to download stored data to a PC
HM35-3	External power converter with U.S. plug adapter, input 100 to 240 VAC, 50/60 Hz

**OPTIONS**

Use order code:	Description
NISTCAL-MD	NIST traceable calibration certificate

SERIES HM28

# PRECISION HANDHELD DIGITAL MANOMETER

High Accuracy (0.2%, 0.1% or 0.05%), Differential, Gage or Absolute

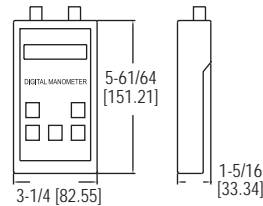

The **Series HM28 Precision Handheld Digital Manometer** is designed to measure a wide range of pressures with up to 0.05% accuracy. The data logging function can store up to 964 readings and transmit the readings to a PC through an IR serial report. The dual line LCD is able to display a resolution to 0.001 of the selected unit and indicate peaks and valleys.

**FEATURES/BENEFITS**

- Measures differential, gage, or absolute pressure
- Able to record up to 964 readings, which can be downloaded to a PC
- Up to 0.05% accuracy

**APPLICATIONS**

- Calibration facilities
- Laboratories

MODEL CHART	
Model	Features
<b>Error limit 0.2% FS for gage, underpressure and differential pressure</b>	
HM28D3B10000	0 to 10 in w.c. (2.5 kPa)
HM28D3C10000	0 to 28 in w.c. (7 kPa)
HM28D3F10000	0 to 120 in w.c. (30 kPa)
<b>Error limit 0.05% FS for gage, underpressure and differential pressure</b>	
HM28D3C30000	0 to 28 in w.c. (7 kPa)
HM28D3F30000	0 to 120 in w.c. (30 kPa)
HM28D3K30000	0 to 100 psi (700 kPa)
<b>For absolute pressure</b>	
HM28A310000	0 to 15.9 psia (0.2% FS (110 kPa abs))

**Note:** Consult factory for 0.10% models.

**SPECIFICATIONS**

**Service:** Air and compatible gases.  
**Accuracy:** (Includes linearity, hysteresis, and repeatability): per order code;  $\pm 0.20\%$  FS  $\pm 1$  digit;  $\pm 0.10\%$  FS  $\pm 1$  digit;  $\pm 0.05\%$  FS  $\pm 1$  digit.  
**Wetted Materials:** 18/8 stainless steel.  
**Temperature Limits:** 23 to 122°F (-5 to 50°C).  
**Storage Temperature:** -4 to 140°F (-20 to 60°C).  
**Humidity:** 30 to 95% rH, non-condensing.  
**Display:** 2 line, 16 character, dot matrix LCD, with switchable display sizes.  
**Power Requirements:** 9 V alkaline battery, installed functional, user replaceable. Can operate from external power supply of 7 to 14 VDC.

**Current Consumption:** < 9 mA.  
**Memory:** 964 measured values. Recording intervals adjustable from manual, 1, 5, 10, 20, 30 s, 1, 2, 3, 5, 10, 30, 60 minutes.  
**Case Protection:** IP54 (NEMA 3).  
**Case Dimensions:** 6" x 3.27" x 1.34" (152 x 83 x 34 mm).  
**Weight:** 9.5 oz (270 g).  
**Process Connections:** Hose; 4/6 mm or 1/8" NPT.  
**Maximum Measurement Rates:** Stand alone: 2-1/2 readings/s (0.1% and 0.05% ratings), 5 readings/s (0.2% rating). Output to RS-232: 20 measurements/s (0.2% rating), 10 measurements/s (0.1% and 0.05% ratings).  
**RS-232 Baud Rate:** Adjustable, 1200, 2400, 4800, or 9600 baud.

**ACCESSORIES**

Model	Description
HM28-0	1/8" NPT adapter (1 piece)
HM28-1	Communication software and cable
HM28-2	Universal power adapter

**OPTIONS**

Use order code:	Description
NISTCAL-MD	NIST traceable calibration certificate



SERIES 1221/1222/1223

# FLEX-TUBE® U-TUBE MANOMETERS

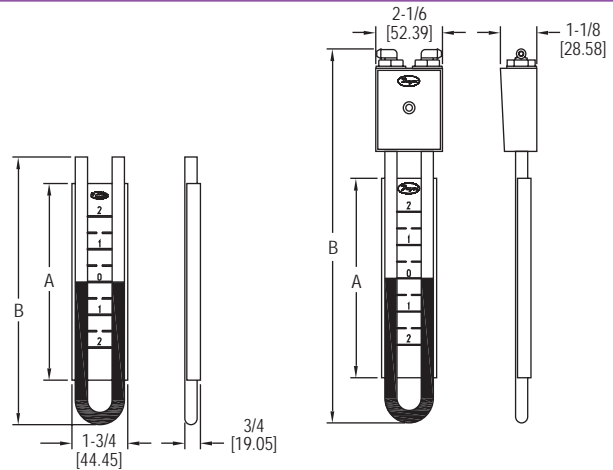

Range		Hg Required to Fill		1221, 2 & 3 Scale Length "A"		1221 & 2 O.A. Length "B"		1223 O.A. Length "B"	
Inches H <sub>2</sub> O	Millimeters H <sub>2</sub> O	Grams	Ounces	W/M	D	W/M	D	W/M	D
8 (4-0-4)	M200 (100-0-100)	178.5	6.3	12-1/4	14	15-1/4	17	18-1/2	19-7/8
12 (6-0-6)	M300 (150-0-150)	225.5	7.9	16-1/4	18-7/8	19-1/4	21-3/4	21-1/8	24-5/8
16 (8-0-8)	M400 (200-0-200)	269	9.5	20-3/8	23-5/8	23-1/4	26-1/2	26-1/8	30-3/8
20 (10-0-10)	-	314.5	11.1	24-1/4	28-1/2	27-1/4	31-1/2	30-1/8	34-3/8
-	M600 (300-0-300)	353.1	12.4	27-7/8	32-7/8	30-3/4	35-3/4	33-5/8	38-5/8
24 (12-0-12)	-	379.7	13.4	28-1/4	33-3/8	31-1/2	36-1/4	33-3/8	39-1/8
36 (18-0-18)	-	491.1	17.3	40-1/4	47-7/8	43-1/4	50-3/4	46-1/8	53-5/8
-	M1000 (500-0-500)	526.6	18.5	43-5/8	52	46-1/2	55	49-3/8	57-7/8

**Note:** Not recommended for vacuum service above 5 in. Hg (68 in w.c.).

The **Series 1221/1222/1223 Flex-Tube® U-Tube Manometers** combine the inherent accuracy of the "U" Tube with the durability of tough, long-lasting plastic construction. The columns are made of 0.375" O.D. flexible and shatterproof clear butyrate tubing and are backed by a white scale channel to provide maximum color contrast. These manometers are ideal wherever a portable, direct reading manometer is needed.

**FEATURES/BENEFITS**

- Suitable for total pressures up to 100 psi
- High contrast scale for better precision when measuring

**APPLICATIONS**

- Duct static pressure
- Calibration labs
- Filter monitoring

**Series 1221 Flex-Tube® U-Tube Manometer**

Our simplest, lowest cost basic U-gage. A dependable U-tube manometer that withstands hard use and provides accurate, high visibility readings. For use with water, mercury or red gage fluid. For mercury filled manometers, a scale clamp bar, Dwyer® Part No. A-363 (available as an extra for Series 1221 — and standard on Series 1222) is recommended. One pair of carrying plugs and a pair of non-kink vinyl tube connectors are included with each manometer.

**Series 1222 Flex-Tube® U-Tube Manometer**

All the features of the 1221 plus magnetic clips for mounting to any vertical steel surface, and clamp bar to insure against U-tube slipping. (Especially recommended for manometers used with mercury.) Both magnets are easily removed and replaced at the user's convenience.

**Series 1223 Flex-Tube® U-Tube Manometer**

Our finest U-gage — for either portable or stationary use. Safety traps prevent loss of indicating fluid in case of accidental over-pressure. Tubing is permanently bonded to a molded, high impact acrylic plastic top that contains safety traps. Large magnetic clips and clamp bar are provided. Standard type "a" connections include two rapid shut-off type molded nylon tubing connections, two 3-foot lengths of flexible Tygon® plastic tubing, and two 1/8" pipe thread to tube adapters.

MODEL CHART			
Model	Model	Model	Ranges
1221-8-W/M	1222-8-W/M	1223-8-W/M	8 (4-0-4) in w.c.
1221-12-W/M	1222-12-W/M	1223-12-W/M	12 (6-0-6) in w.c.
1221-16-W/M	1222-16-W/M	1223-16-W/M	16 (8-0-8) in w.c.
1221-20-W/M	1222-20-W/M	1223-20-W/M	20 (10-0-10) in w.c.
1221-24-W/M	1222-24-W/M	1223-24-W/M	24 (12-0-12) in w.c.
1221-36-W/M	1222-36-W/M	1223-36-W/M	36 (18-0-18) in w.c.
1221-M200-W/M	1222-M200-W/M	1223-M200-W/M	M200 (100-0-100) mm w.c.
1221-M300-W/M	1222-M300-W/M	1223-M300-W/M	M300 (150-0-150) mm w.c.
1221-M400-W/M	1222-M400-W/M	1223-M400-W/M	M400 (200-0-200) mm w.c.
1221-M600-W/M	1222-M600-W/M	1223-M600-W/M	M600 (300-0-300) mm w.c.
1221-M1000-W/M	1222-M1000-W/M	1223-M1000-W/M	M1000 (500-0-500) mm w.c.

**Note:** To order models with red gage fluid change -W/M to -D.

OPTIONS	
To order add suffix:	Description
-NIST	NIST traceable calibration certificate
<b>Example:</b> 1230-8-W/M-NIST	

ACCESSORIES - STANDARD	
Model	Description
1221	2 plastic carrying plugs; 2 flexible plastic tubing connectors for attachment of 3/16" rubber or plastic tubing without kinking. 1 ounce bottle .826 sp. gr. red gage fluid furnished for "D" style manometers. Fluorescein green dye concentrate furnished with "W/M" style manometers.
1222	2 magnetic mounting clips; tube clamp; 2 plastic carrying plugs and 2 flexible plastic tubing connectors for attachment of 3/16" rubber or plastic tubing without kinking. 1 ounce bottle .826 sp. gr. red gage fluid furnished for "D" style manometers. Fluorescein green dye concentrate furnished with "W/M" style manometers.
1223	Magnetic mounting clips; tube clamp and Type "a" connections consisting of two rapid shut off molded nylon tubing connectors; two 1/8" pipe thread to tube adapters; two 3-foot lengths of Tygon® plastic tubing, 1 ounce bottle .826 sp. gr. red gage fluid is furnished for "D" style manometers; fluorescein green dye concentrate with "W/M" style.

Tygon® is a registered trademark of Saint-Gobain Performance Corporation

# SLACK TUBE® MANOMETER

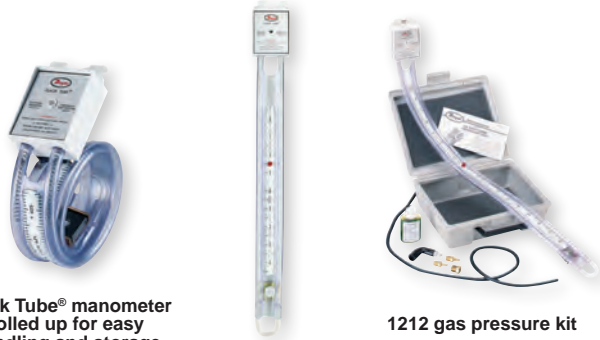

Slack Tube® manometer rolled up for easy handling and storage

1212 gas pressure kit

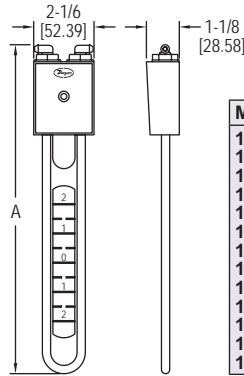

Model	Dimension "A"
1211-8	16-3/4 [425.45]
1211-12	20-3/4 [527.05]
1211-16	24-3/4 [628.65]
1211-24	32-3/4 [831.85]
1211-30	38-3/4 [984.25]
1211-36	44-3/4 [1136.65]
1211-48	56-3/4 [1441.45]
1211-60	68-3/4 [1746.25]
1211-72	80-3/4 [2051.05]
1211-120	128-3/4 [3270.25]
1211-50	28-3/4 [730.25]
1211-100	48-3/4 [1238.25]
1211-200	87-3/4 [2228.85]

The Series 1211 Slack Tube® Manometer is as accurate as the finest laboratory "U" gages, but is designed to roll up compactly for easy carrying. These manometers cover a wide range of pressure readings from 4-0-4 inches up to 60-0-60 inches.

The Model 1212 Gas Pressure Kit is supplied with a 1211-16 Slack Tube® Manometer, carrying case, necessary tubing, and connection fittings for checking gas pressures in virtually all gas appliances.

**FEATURES/BENEFITS**

- Rolls up for easy storage and transport
- Over pressure safety traps to prevent loss of fluid due to over range pressures or surges in pressure

**APPLICATIONS**

- Filter monitoring
- Duct static pressure for setting damper position

MODEL CHART					
Model	Range, In.	Hg Req'd (oz.)	Metric Model	Range, CM	Hg Req'd (oz.)
1211-8	4 to 0 to 4	6	1211-50	25 to 0 to 25	11
1211-12	6 to 0 to 6	7	1211-100	50 to 0 to 50	18-1/2
1211-16	8 to 0 to 8	9	1211-200	100 to 0 to 100	35
1211-24	12 to 0 to 12	12-1/2			
1211-30	15 to 0 to 15	15			
1211-36	18 to 0 to 18	17-1/2			
1211-48	24 to 0 to 24	22-1/2			
1211-60	30 to 0 to 30	27			
1211-72	36 to 0 to 36	32			
1211-120	60 to 0 to 60	57			

INCLUDED WITH THE 1212 KIT	
Description	
(1) #1211-16 Slack Tube® Manometer, reads pressure to 16" water*, (1) Carrying case, plastic, 8-1/2" x 7" x 3-1/8", (1) 1 oz. bottle Fluorescein green color concentrate with wetting agent, (2) 1/8" pipe thread rubber tubing adapters, (1) 1/8" to 1/4" pipe thread bushing, (1) 3' L 3/16" rubber tubing, (1) Rubber tubing adapter to fit standard 7/16" dia. spud.	
*Other ranges available.	

MODEL CHART	
Model	Description
1212	Gas pressure kit

ACCESSORIES - STANDARD	
Description	
Plastic case, magnetic mounting clips, two rapid shutoff type molded nylon rubber tubing connectors and one bottle of fluorescein green color concentrate with wetting agent.	

SERIES 1227

# DUAL RANGE FLEX-TUBE® U-INCLINED MANOMETERS

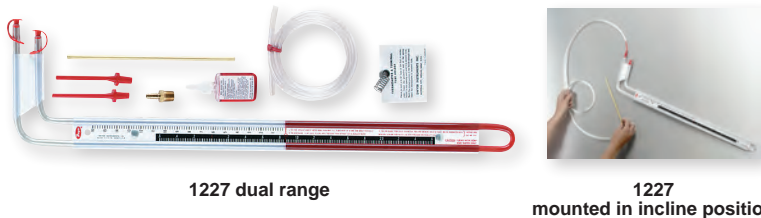

1227 dual range

1227 mounted in incline position

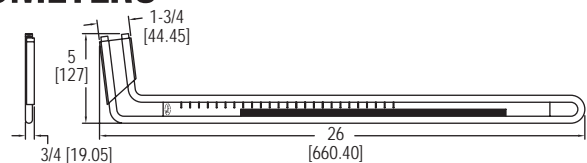

As Vertical U-Tube Manometer	As Inclined Manometer
0-16" water with 1" major divisions, .2" minor divisions	Scale is 17" long, reading .20-0-2.6" water with .02" minor divisions
Model 1227M (metric) is 0-400 mm water column	Model 1227M (metric) is -5 to 0 to 70 mm water column

The Series 1227 Dual Range Flex-Tube® U-Inclined Manometers are versatile, low cost manometers that can be used to read high-range pressure on the right leg or as an inclined manometer to read low-range pressure on the bottom leg. It is made of a sturdy, clear plastic and offers direct readings as a U-tube or an inclined gage. Magnetic clips are attached to the unit to hold it in position on any steel duct surface and instructions are conveniently printed directly on the scale.

**FEATURES/BENEFITS**

- Reads 0 to 16 in w.c. as a U-tube and -0.20 to 0 to 2.6 in w.c. as an inclined gage
- Clear, shatterproof indicating tube provides overpressure protection
- Black markings on a stark white scale for positive definition

**APPLICATIONS**

- Fan status
- Filter monitoring

MODEL CHART	
Model	Description
1227	English units
1227M	Metric units

ACCESSORIES - STANDARD	
Description	
Two plastic carrying plugs with retainers for use when manometer is not in service. Two magnetic clips to hold instrument to metal surface. Flexible red vinyl plastic tubing connectors. Brass terminal tube 1/4" diameter x 8" long. One terminal tube holder. Brass adapter, 1/8" pipe thread to plastic tubing. One 4-1/2" length of Tygon® plastic tubing. One 1 ounce bottle .826 sp. gr. red gage fluid. Vinyl carrying case.	

USA: California Proposition 65  
 ⚠️WARNING: Cancer and Reproductive Harm - www.P65Warnings.ca.gov

Tygon® is a registered trademark of Saint-Gobain Performance Corporation



SERIES 1213

# GAS PRESSURE MANOMETER

## The "Tube in a Tube" Direct Reading Manometer

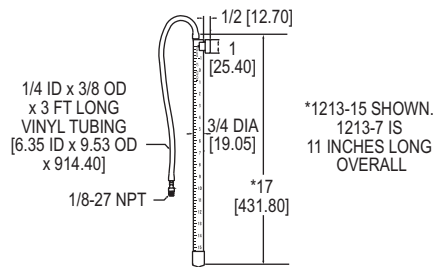
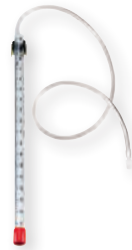

The **Series 1213 Gas Pressure Manometer** provides visual indication of pressure of natural gas up to 15 in w.c. Tap water is used as the sensing media and a magnetic clip provides temporary or permanent mounting. The 1213 is made of a durable plastic for years of trouble-free service, and includes 3' of vinyl tubing and 1/8" nylon male NPT to barb fitting.

**FEATURES/BENEFITS**

- Used to monitor any compatible gas up to 15 in w.c.
- Durable plastic housing for long term use
- Economically priced

**APPLICATIONS**

- Combustion supply gas monitoring

**SPECIFICATIONS**

**Temperature Limit:** 140°F (60°C) maximum.  
**Pressure Limits:** 15 in w.c. (381 mm).  
**Piping Connections:** 1/8" male NPT connector provided.  
**Wetted Materials:** Vinyl, PVC and nylon.  
**Weight:** 5 oz (142 g).  
**Agency Approvals:** Meets the technical requirements of EU Directive 2011/65/EU (RoHS II).

**MODEL CHART**

Model	Length (mm)
1213-15	7" (177.8)

SERIES MARK II

# MOLDED PLASTIC AIR VELOCITY METERS

Low in Cost, Direct Reading Scales Offer 3% Accuracy, For Portable or Stationary Applications



27



40-AV – Shown with standard swing-out stand and leveling screw installed.

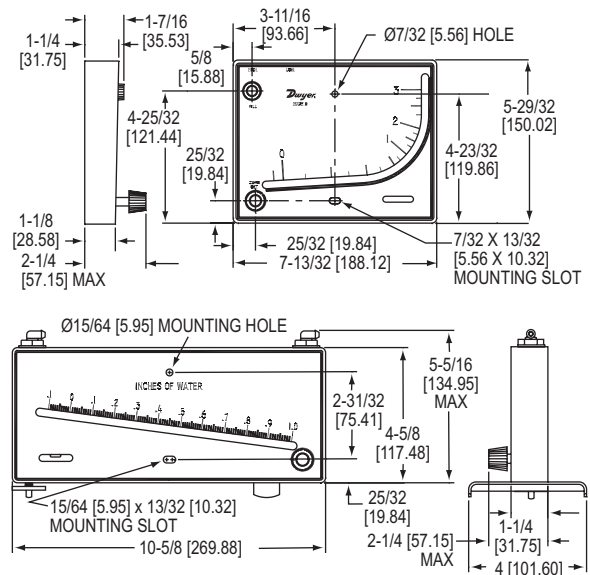

The **Series Mark II Molded Plastic Air Velocity Meters** offer the accuracy and durability of our Mark II manometers with direct air velocity readings. They are designed to be used with Dwyer's Series 160 line of Pitot tubes (not included).

**FEATURES/BENEFITS**

- Thick white styrene-acrylonitrile housing is virtually indestructible
- Moderate overpressures are accommodated by an overflow tank (Model 25) or float operated overflow traps (Model 40)
- Able to be mounted on any vertical surface

**APPLICATIONS**

- Measure air velocity in ducts

**MODEL CHART**

Model	Range
Mark II 27	0 to 7000 FPM
Mark II 28	0 to 10500 FPM
Mark II 40-250 Pa-AV	0 to 21 MPS

**Note:** Pitot tube not included with models above.

**ACCESSORIES**

Model	Description
A-612	Portable stand (for models 27, 28)

**OEM SPECIALS**

All models of the Dwyer® Mark II molded plastic air velocity meters can be supplied with your logo or special scale in OEM quantities. Consult factory for details. See also our Digital Manometers and Pitot tubes.



# AIR VELOCITY METER

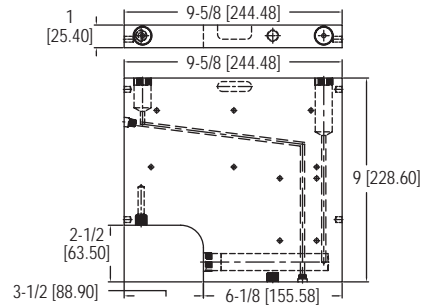

The **Series 400 Air Velocity Meter** offers the convenience of a dual purpose instrument with high accuracy and easy-to-read scales. It can be used to balance air conditioning systems, measure pressure drop across filters, and test fan and blower discharge and inlet pressures. Series 400 kits include a manometer, Pitot tube, necessary tubing and connectors, red gage fluid, and carrying case.

### FEATURES/BENEFITS

- Red figures display velocity in FPM and black figures display air pressure in inch w.c.
- No conversion tables needed for air at standard conditions
- Available with Pitot tubes and carrying case

### APPLICATIONS

- Air balancing
- Building commissioning

Model	Range in w.c.	Velocity FPM	Minor Div.; Range in w.c.		Pitot Tube
			Inclined	Vertical	
<b>400-10-Kit</b>	0 to 10	400 to 12600	.01, 0 to 1.0	.10, 1-10	18 in
<b>400-10-Gage</b>	0 to 10	400 to 12600	.01, 0 to 1.0	.10, 1-10	None

\*Rated for total pressures to 100 psig (6.89 bar); temperatures to 150°F (65°C)



### Complete kit, Model 400-10

Size\*\*: 11-1/2"H x 20-1/4"W x 1-1/2"D  
Weight: Only 13-1/4 lb with equipment

\*\*Contact factory for extra long steel cases for use with longer Pitot tubes

## MODEL 460

# AIR METER/DRAFT GAGE

A Low-Cost, Direct Reading Instrument Used for Air Velocity & Static Pressure Tests



Furnace draft



Grille velocities

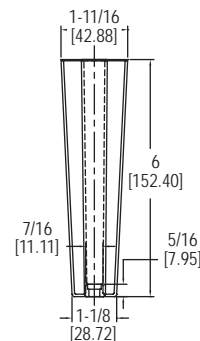

The **Model 460 Air Meter/Draft Gage** is popular for servicing HVAC equipment because of its consistent, accurate results. The direct reading velocity and static pressure scales show supply and return grille velocities, furnace draft, and pressure drop across filters. The 460 is made of a rugged plastic for daily use.

### FEATURES/BENEFITS

- High and low range velocity in one unit
- Simple and quick operation with highly accurate results
- Compact housing for easy portability

### APPLICATIONS

- Measuring grille velocities, furnace draft, and pressure drop across filters

ACCESSORIES	
Model	Description
<b>A-378</b>	Tube of 3 replacement floats
<b>A-379</b>	Supply grille probe
<b>A-380</b>	Return grille probe
<b>A-381</b>	Cleaning kit including 1 anti-static chemically treated pipe stem cleaner and nylon high range orifice cleaner

MODEL CHART	
Model	Description
<b>460</b>	Air meter, complete kit



### Complete pocket-size kit

Includes air meter, return and supply grille probes, angle connector, cleaning materials, instruction card, air velocity calculator and carrying case.

# STAINLESS STEEL PITOT TUBE

## ASME Design Meets AMCA and ASHRAE Codes

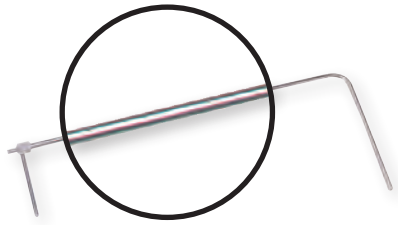

Standard Model 160 pitot tube

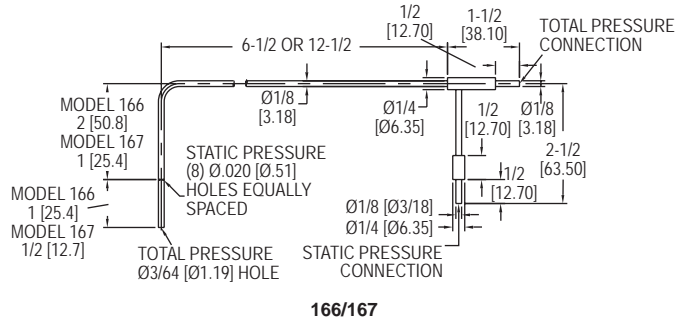
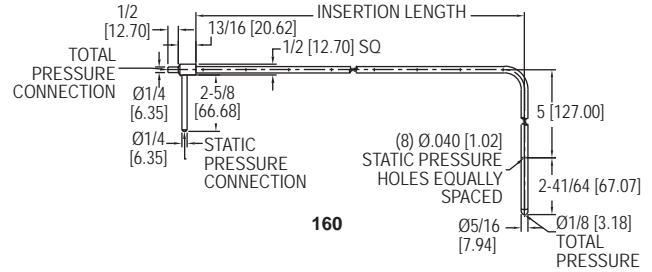
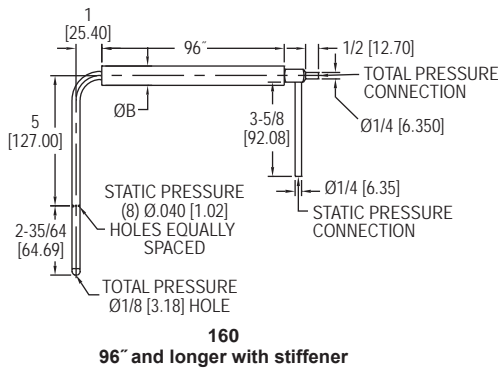

The **Series 160 Stainless Steel Pitot Tube** is constructed from corrosion resistant stainless steel with permanently etched insertion depth graduations for a lifetime of service. The static pressure port is parallel to the sensing tube to allow quick, easy alignment of the tube with air flow. A universal model fits the user supplied 3/4" schedule 40 pipe in any length.

**FEATURES/BENEFITS**

- Low sensitivity to misalignment up to 15 degrees
- No calibration needed due to ASHRAE tip design
- Silver soldered connections for leak-proof operation
- 5/16" models rated to 1500°F (815.5°C)

**APPLICATIONS**

- Monitor or control air velocity or air flow when combined with differential pressure gage, switch, or transmitter

**ACCESSORIES**

Model	Description
<b>A-156</b>	Flange mounting plate 1/2" female NPT
<b>A-158</b>	Split flange mounting. Can be added to any Dwyer® No. 160 standard pitot tube. Cadmium plated steel. Gasket is pattern for mounting holes. Secure flange loosely to tube, adjust tube depth and tighten screws. Gasket of 1/16" Neoprene fits tightly around tube and against duct for leak-proof seal. Nuts, washers included.
<b>A-159</b>	Mounting gland. Versatile adapter slips on any Series 160, 5/16" standard pitot tube made after Dec. 1990. Two-part stainless steel fitting slides over tube and provides permanent, secure mounting. Where duct interior is accessible, use the washers and jam nut supplied. For blind applications or in thicker materials, use model A-156 flange mounting plate. Once tube is adjusted to proper depth and angle, tighten smaller hex bushing to lock position. Graphite bushing inside assures leak-proof seal even at higher temperatures. TFE bushing also available. <b>Note:</b> For full insertion with this fitting, order next longer pitot tube. A-159 mounting gland is used for both duct mounting and flange mounting.
<b>A-160-CASE A-397</b>	Carrying case for pitot tubes up to 48" Step drill. For fast, convenient installation of pitot tubes in sheet metal ducts. No center punch needed; automatic de-burring. Drills six sizes from 3/16"-1/2" in 1/16" increments.

MODEL CHART			
Standard 5/16" Diameter Model	Insertion Length	Longer Length with Stiffener Model	Insertion Length
<b>160-8</b>	8-5/8"	<b>160-96</b>	96"
<b>160-12</b>	12-5/8"	<b>Pocket Size 1/8" Diameter Model</b>	<b>Insertion Length</b>
<b>160-18</b>	18-5/8"	<b>166-6</b>	6"
<b>160-24</b>	24-5/8"	<b>166-12</b>	12"
<b>160-36</b>	36-5/8"	<b>167-6</b>	6"
<b>160-48</b>	48-5/8"	<b>167-12</b>	12"
<b>160-60</b>	60-5/8"		
Model	Description		
<b>160-KIT</b>	Kit containing 160-18, 160-24, 160-36, 160-48, and carrying case		

OPTIONS	
To order add suffix:	Description
<b>-CF</b>	1/8" male NPT compression fitting, mounting option for Series 166/167
<b>Example:</b> 166-6-CF	

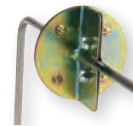

A-158



A-159



To flange mount, the A-159 must be used with the A-156 flange mounting plate.

A-160-CASE

A-397

# STRAIGHT STAINLESS STEEL PITOT TUBE



Sensing profile

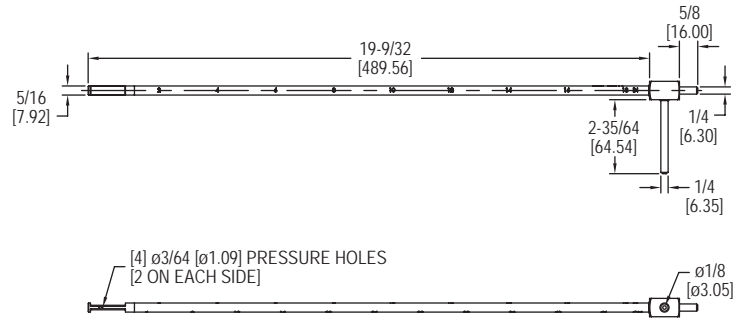

The **Series 160F Straight Stainless Steel Pitot Tube** is constructed from corrosion resistant stainless steel with permanently etched insertion depth graduations for a lifetime of service. The static pressure port is parallel to the sensing tube to allow quick, easy alignment of the tube with air flow. The straight design allows for easy insertion into ducts through grills and pressure taps, as well as aids in positioning in hard to reach locations where a hook style Pitot tube may not allow access.

**FEATURES/BENEFITS**

- Straight design allows for easy insertion into ducts
- Permanent stamped insertion depth graduations facilitate accurate positioning
- Alignment indicator helps keep tip parallel to flow

**APPLICATIONS**

- Monitor or control air velocity or air flow when combined with differential pressure gage, switch, or transmitter where hook style Pitot tubes don't allow access

MODEL CHART			
Model	Probe Length	Model	Description
160F	18" (457.2 mm)	160F-KIT	Kit containing 160-18, 160-24, 160-36, 160-48, and carrying case
160F-24	24" (609.6 mm)		
160F-36	36" (914.4 mm)		
160F-48	48" (1219.2 mm)		
160F-60	60" (1524 mm)		

SPECIFICATIONS	
<b>Wetted Material:</b>	304 SS.
<b>Accuracy:</b>	±2% FS, 0 to 9000 FPM (45 M/s).
<b>K-Factor:</b>	0.81.
<b>Temperature Limit:</b>	1500°F (815°C).
<b>Insertion Length:</b>	18" (44 cm).
<b>Process Connections:</b>	1/4" OD.
<b>Weight:</b>	4.3 oz (122 g).
<b>Agency Approvals:</b>	Meets the technical requirements of EU Directive 2011/65/EU (RoHS II).

ACCESSORIES	
Model	Description
A-156	Flange mounting plate 1/2" female NPT
A-158	Split flange
A-159	Mounting gland
A-160-CASE	Carrying case for pitot tubes up to 48"
A-397	Step drill

MODEL 160E

# ELLIPSOIDAL TIP PITOT TUBE

Designed to Meet ISO Standard 3966

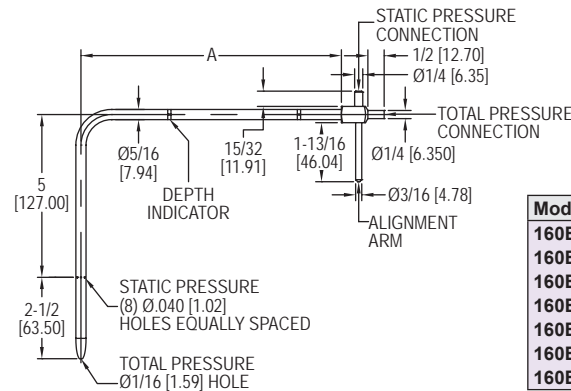

Model	Dim A
160E-00	7-7/8 [200.03]
160E-01	11-7/8 [301.63]
160E-02	18-7/8 [479.43]
160E-03	31-1/2 [800.10]
160E-04	39-1/2 [1003.30]
160E-05	48 [1219.20]
160E-06	59-7/8 [1520.83]

The **Series 160E Ellipsoidal Tip Pitot Tube** uses a precision crafted tip configuration, which allows air to pass smoothly with minimum turbulence for consistent, reliable readings. Sliding depth indicators grip firmly to ensure uniform insertion when measuring traverses across ducts. Total and static pressure taps are 1/4" (6 mm) and are permanently silver soldered to the connection block, making them leak-proof and durable.

**FEATURES/BENEFITS**

- Designed to meet ISO standard 3966 commonly required in UK and Europe
- Ellipsoidal tip design for improved accuracy
- 304 SS construction adds strength and resists corrosion
- Adjustable depth indicators for fast, consistent traverses
- Alignment indicator helps keep tip parallel to flow

**APPLICATIONS**

- Monitor or control air velocity or air flow when combined with differential pressure gage, switch, or transmitter

MODEL CHART	
Model	Insertion in Meters
160E-00	0.2
160E-01	0.3
160E-02	0.48
160E-03	0.8
160E-04	1.0
160E-05	1.22
160E-06	1.52

ACCESSORIES	
Model	Description
A-160-CASE	Carrying case for pitot tubes up to 1.22 m

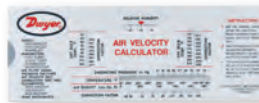

Handy A-532 slide chart speeds air velocity calculations. All plastic, stays clean for years. Included with each pitot tube.

**Dwyer**

SERIES 160S

**"S" TYPE STAINLESS STEEL PITOT TUBES**

Large, Open Tip Design Resists Fouling; Optional Permanent Mount Models

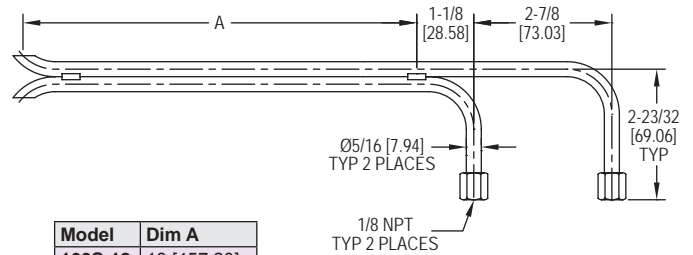
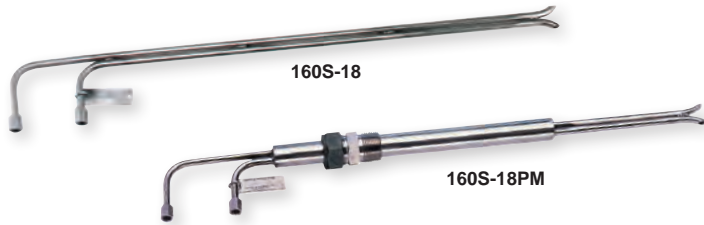

Model	Dim A
160S-18	18 [457.20]
160S-24	24 [609.60]
160S-36	36 [914.40]
160S-48	48 [1219.20]
160S-60	60 [1524.00]

The **Series 160S "S" Type Stainless Steel Pitot Tubes** are designed specifically for flow measurement of dirty, particulate laden air or gas streams typical in smoke stack and other environmental testing. Total and static pressure tubes are precisely aligned and welded together every 6 inches for maximum accuracy, strength, and long term durability. Permanent mount (PM) models include a 1" welded stainless steel sleeve and adjustable compression fitting with 1" MNPT mounting threads.

**FEATURES/BENEFITS**

- Large 5/16" stainless steel tubing resists plugging under harsh conditions
- 1/8" FNPT connections are permanently welded to unit
- Able to be used in up to 1500°F (815.5°C) and 100 psig (6.89 bar)

**APPLICATIONS**

- Monitor or control air velocity or air flow in particulate laden air streams

**MODEL CHART**

Model	Insertion in Inches	Perm. Mtg. Model	Insertion in Inches
160S-18	18	160S-18PM	18
160S-24	24	160S-24PM	24
160S-36	36	160S-36PM	36
160S-48	48		
160S-60	60		
160S-72	72		

**Note:** Permanent Mounting (PM) models include 1 inch dia. welded stainless steel sleeve and adjustable compression fitting with 1 inch male NPT mounting threads. Adjust depth, lock in place.

**ACCESSORIES**

Model	Description
A-160-CASE	Carrying case for pitot tubes up to 48"

**MODEL 166T****TELESCOPING STAINLESS STEEL PITOT TUBE**

Adjustable Design Extends Insertion Length to 36 Inches

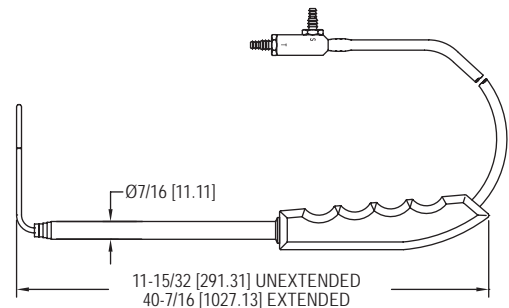

The **Model 166T Telescoping Stainless Steel Pitot Tube** is a unique air flow sensor which can quickly and easily be adjusted for any duct insertion length from 11.5 to 36 inches (29.2 to 91.4 cm), allowing it to replace up to 5 conventional fixed length Pitot tubes. The telescoping sections lock in place as they are extended, which enables the use of the handheld grip to gauge proper alignment of the tip with the airstream. For even greater convenience, it is securely protected by a custom fitted polyethylene carrying case.

**FEATURES/BENEFITS**

- Adjustable length can replace up to 5 fixed length Pitot tubes
- Stainless steel construction resists corrosion
- 1.8" diameter hemispherical tip has 1.0 flow coefficient

**APPLICATIONS**

- Monitor or control air velocity or air flow when combined with differential pressure gage, switch, or transmitter where varying lengths are needed

**MODEL CHART**

Model	Description
166T	Telescoping pitot tube



# AVERAGING AIR FLOW GRID

Extends Over 50" to Aid in Air Flow Output Checks

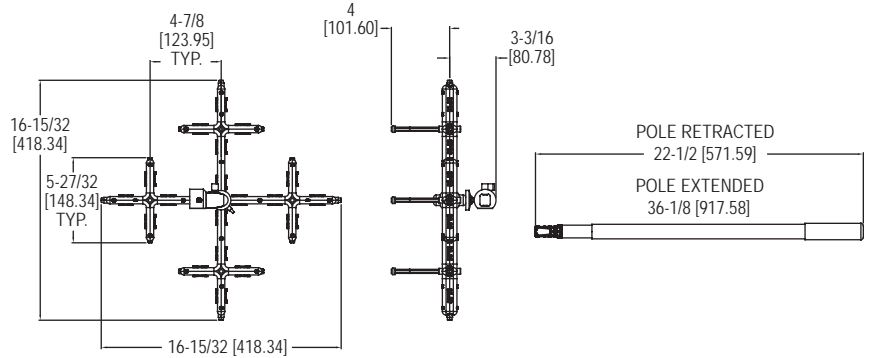

The **Model 160G Averaging Air Flow Grid** utilizes 16 sensing points to provide precision sensing across its 16.5" (41.9 cm) length and width. The ball pivot joint and tightening nut allows the user to position the sensing grid at any angle in any direction for ease of use in hard to reach locations. The included color coded tubing connects to the integral barbed fittings, providing a differential pressure signal to a gage or manometer where the readings can be converted into a velocity or flow reading.

**FEATURES/BENEFITS**

- Maximum reach of approximately 48" (122 cm)
- 16 sensing points provide an accurate average flow

**APPLICATIONS**

- Measure face air velocity on grills, diffusers, registers, exhaust hoods

**SPECIFICATIONS**

**Service:** Air or compatible gases.

**Wetted Materials:** Grid: Black polycarbonate; Ball pivot joint: AL, plastic; Handle: Aluminum; Standoffs: Aluminum with rubber bumpers, two sets: 1.25" (31.7 mm) and 2" (50.8 mm), 1/8" ID / 1/4" OD; Tubing: Two 10' (3 m) lengths of silicone rubber.

**Accuracy:** ±2% FS.

**Temperature Limits:** -40 to 257°F (-40 to 125°C).

**K Factor:** 0.84.

**Range:** 1000 to 5000 FPM (5 to 25 m/s).

**Process Connection:** 1/8 to 1/4" ID tubing.

**Weight:** 1.75 lb (0.79 kg).

**Agency Approvals:** RoHS.

MODEL CHART	
Model	Description
160G	Averaging air flow grid

ACCESSORIES	
Model	Description
UHH-C2	Protective hard case



**MODEL ANE-1**

# DIFFERENTIAL PRESSURE ANEMOMETER

Bi-Directional Anemometer, No Sensing Electronics

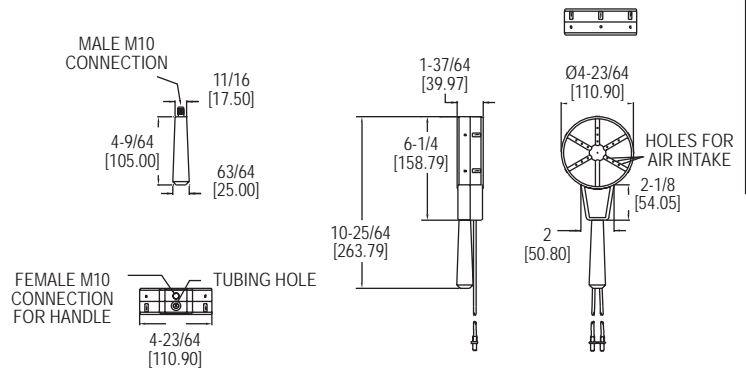

The **Model ANE-1 Differential Pressure Anemometer** is a robust and durable bi-directional anemometer with no moving parts or sensing electronics. Using the installed tubing, the ANE-1 connects easily to any manometer or applicable pressure sensing device and is capable of measuring a wide velocity range. The air velocity range and accuracy is dependent on the installed manometer, and the ANE-1 retains the accuracy as long as it is dust free.

**FEATURES/BENEFITS**

- Wide velocity range dependent on connected manometer
- Includes 5' of blue and 5' of red silicone tubing with a removable adapter sized 2 mm OD to 3/16" OD

**APPLICATIONS**

- Measure face air velocity on grills, diffusers, registers, exhaust hoods

**SPECIFICATIONS**

**Service:** Clean air only.

**Wetted Materials:** Anemometer: ABS; Tubing: Silicone; Handle: Phenolic.

**Dimensions:** Tubing: 2 mm ID x 4.5 mm OD; Adapter: 2 mm OD to 3/16" OD connections.

**Temperature Limits:** 23 to 122°F (-5 to 50°C).

**K-Factor:** 0.843.

**Process Connections:** 2 removable 5" (12.7 cm) tubing 3/16" ID.

**Weight:** 7.7 oz (220 g).

MODEL CHART	
Model	Description
ANE-1	Differential pressure anemometer

**Dwyer**  
MODEL 480

# VANEOMETER™ SWING VANE ANEMOMETER

Use This Sensitive Dwyer Unit to Measure Low Air Velocities — at Low Cost



Use a Vaneometer™ swing vane anemometer to measure velocity of air flow into laboratory fume hoods and at paint spray booths to determine when to change filters. Or wherever needed to meet OSHA standards of ventilation for smoke, dust or fume removal.

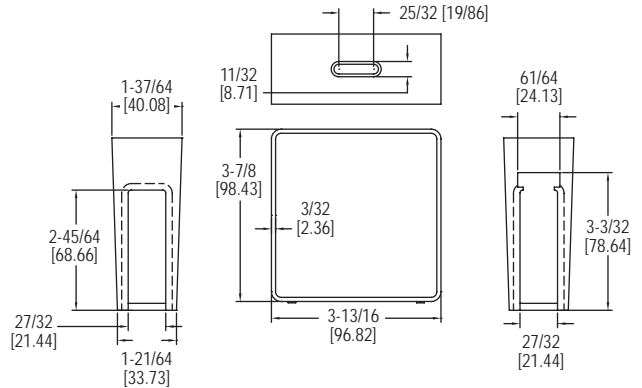

The **Model 480 Vaneometer™ Swing Vane Anemometer** is a durable, economically priced instrument specifically designed to simplify the measurement of low air velocities. It is accurate to ±5% of full-scale to 100 FPM and ±10% from 100 FPM to the top of scale. It has a spirit level to ensure accurate readings and the large scales are easy to read and visible from both sides.

MODEL CHART	
Model	Description
480	25 to 400 FPM
M480	0 to 2.0 m/s

**FEATURES/BENEFITS**

- Small size and weight for easy portability
- Easy to clean ABS plastic housing

**APPLICATIONS**

- Measure air flow into laboratory fume hoods

ACCESSORIES	
Model	Description
A-390	Extra vanes, pkg. of 2

**SERIES MARK II**

# WIND SPEED INDICATOR



Includes ABS plastic vane, 50' tubing, mounting hardware and gage fluid.

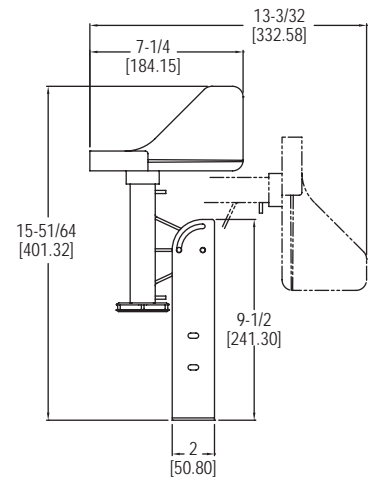
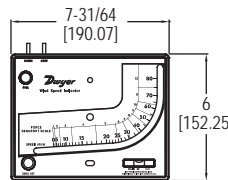

The **Series Mark II Wind Speed Indicator** indicates wind speed directly on the liquid filled scale reading in both miles per hour (0-80) and Beaufort scale (1-12). A metric model is also available, which reads the same as above, but reading 0-130 kilometers per hour. The Mark II Wind Speed Indicator is an accurate, economically priced option for measuring wind speed.

MODEL CHART	
Model	Scale
Mark II WSI	mph
Mark II WSI Metric	kph

**FEATURES/BENEFITS**

- Durable molded white instrument with gold scale
- English and metric units available

**APPLICATIONS**

- Weather monitoring stations

# PORTABLE WIND METER



Hold this way  
for low scale reading



For high scale reading,  
finger covers hole

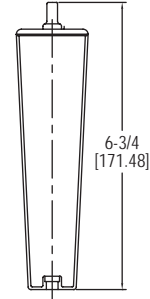
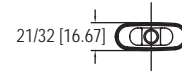

Dimensions: 5/8" W X 6-3/4" H X 17/32" D

The **Portable Series Wind Meter** is used to indicate wind speed and is ideal for yachtsmen, outdoors-men, and farmers. By holding the meter at eye level with the back of the unit to the wind, the white ball in the tube indicates wind speed. The meter has two scales for maximum accuracy.

**FEATURES/BENEFITS**

- Direct reading requires no calculations
- Dual scales to fit any requirement

**APPLICATIONS**

- Fishing, hunting, golf

MODEL CHART	
Model	Scale
Wind Meter-MPH	mph
Wind Meter-KNOT	knots
Wind Meter-KPH	kph
Wind Meter-MPS	mps

ACCESSORIES	
Model	Description
A-376	Replacement floats for windmeter, tube of 3

**MODEL MW-1**

# POCKET WIND METER

Measures Wind Speed and Temperature, Wide Range

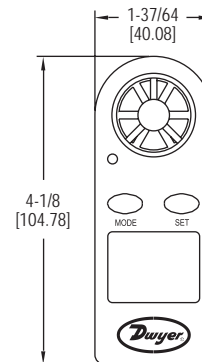

The **Model MW-1 Pocket Wind Meter** measures wind speed and temperature via the integral vane and thermo-anemometer sensor. Users can view readings on the four-digit LCD with wind speed bar graph and select units for air velocity and temperature. The MW-1 also features automatic shut-off, detailed instruction manual, and protective plastic water resistant housing that floats.

**FEATURES/BENEFITS**

- User selectable units to fit any requirement
- Auto shut-off to conserve battery life
- Water resistant plastic housing floats

**APPLICATIONS**

- Balancing applications
- Energy audits
- HVAC inspection

MODEL CHART	
Model	Description
MW-1	Hand-held, mini-vane thermo-anemometer

SPECIFICATIONS	
<b>Air Velocity Range:</b>	0 to 30 m/s, 0 to 5860 ft/min, 0 to 90 km/h, 0 to 65 mph, 0 to 55 knots.
<b>Temperature/Wind-Chill Ranges:</b>	14 to 113°F (-10 to 45°C).
<b>Temperature Resolution:</b>	0.36°F (0.2°C).
<b>Accuracy:</b>	Wind speed: ±5% of reading. Temperature: ±3.6°F (±2°C).
<b>Resolution:</b>	0.1 m/s, 19 ft/min, 0.3 km/h, 0.2 mph, 0.2 knots.
<b>Sample Time:</b>	1 reading per second.
<b>Water-Resistant:</b>	Up to 3' (1 m).
<b>Power Requirements:</b>	3 V CR2032 or BR1225 lithium metal battery, installed functional, user replaceable.
<b>Auto-Off:</b>	14 minutes after last key is pressed.
<b>Impeller:</b>	Plastic, replaceable.
<b>Case:</b>	Plastic.
<b>Display:</b>	2.32 x 2" (59 x 51 mm).
<b>Weight:</b>	1.84 oz (52.1 g).
<b>Agency Approvals:</b>	CE.

ACCESSORIES	
Model	Description
A-166	Replacement vane for MW-1



**Dwyer**

MODEL VT-300

**MINIATURE VANE THERMO-ANEMOMETER**

Telescoping Probe Measures Air Velocity, Air Volume, Temperature, and Humidity

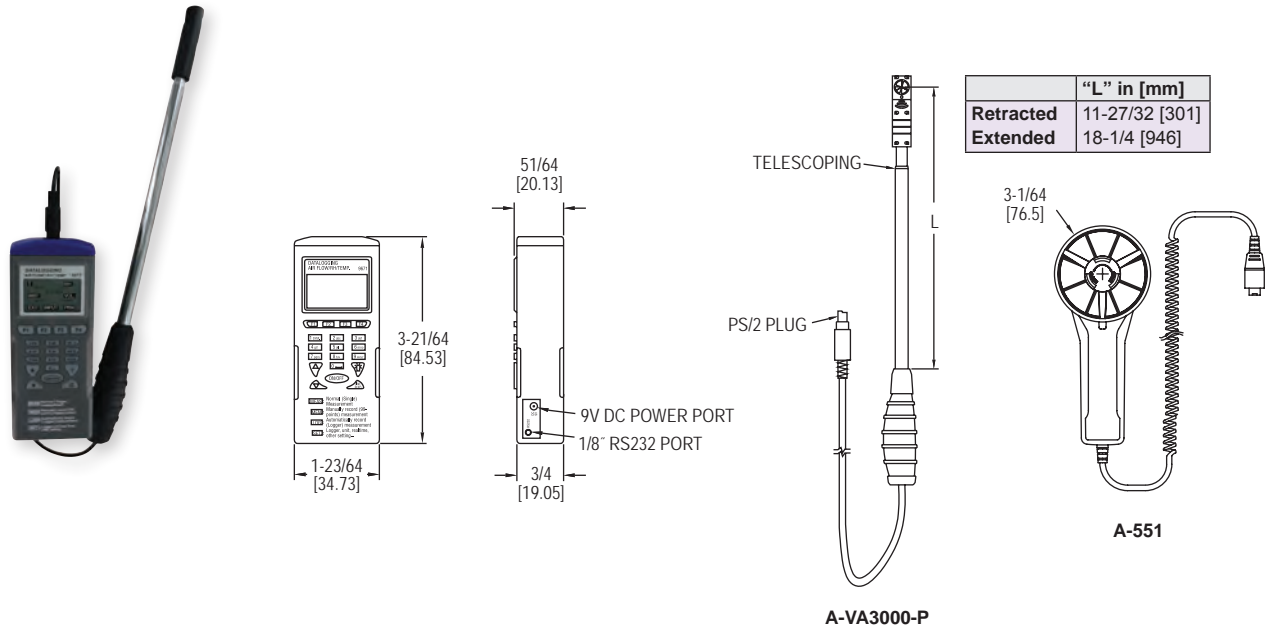

The **Model VT-300 Miniature Vane Thermo-Anemometer** measures air velocity, air volume, temperature, and humidity inside air ducts. This meter includes a telescoping vane probe that is only 0.7" (18 mm) in diameter that allows duct traverse measurements up to 20" ducts. User-selectable units include ft/min, m/s, knots, mph, and km/hr. The vane probe has a built-in sensor to record temperature in °F or °C, as well as humidity in %RH. There are three modes which include viewing data in real time, manual recording, and automatic recording. Model VT-300 can store measurements that can later be transferred to a PC via RS-232 communication. The vane probe is detachable for easy replacement, if necessary. Each unit is supplied with a hard carrying case, batteries, logging software CD, USB to RS-232 cable and instruction manual.

**FEATURES/BENEFITS**

- 3-in-1 parameters: air velocity/flow, RH, and temperature
- Telescoping probe for traversing ducts up to 20"
- Built-in data logging for paperless reporting
- Vane anemometer offers wider application use vs pitot or hotwire
- Hard case, batteries, and software included

**APPLICATIONS**

- Building commissioning
- Building HVAC test and balance
- Critical environment testing
- Industrial process verification
- Instrumentation validation

**MODEL CHART**

Model	Description
VT-300	Miniature vane thermo-anemometer

**ACCESSORIES**

Model	Description
A-VT300-P	Replacement probe with miniature vane
A-551	Replacement probe with large vane

**SPECIFICATIONS****AIR VELOCITY**

**Range:** 98.4 to 3937 ft/min (0.5 to 20 m/s).  
**Accuracy:** ±3% of reading + 0.2 m/s.  
**Resolution:** 0.1 m/s.  
**Response Time:** 1 s.

**TEMPERATURE**

**Range:** -4 to 140°F (-20 to 60°C).  
**Accuracy:** ±1°F (±0.6°C) from -4 to 122°F (-20 to 50°C); ±2.2°F (±1.2°C) from 122 to 140°F (50 to 60°C).  
**Resolution:** 0.1°F (0.1°C).  
**Response Time:** 60 s (typ).

**RELATIVE HUMIDITY**

**Range:** 0.1 to 99.9% RH.  
**Accuracy:** ±3% RH at 25°C (10 to 90% RH); ±5% RH (0.1 to 10% RH, 90 to 99.9% RH).  
**Resolution:** 0.1% RH.  
**Response Time:** 60 s (typ).

**AIR VOLUME**

**Range:** 0 to 99,999 (CFM or m<sup>3</sup>/s).  
**Resolution:** 0.1 (0 to 9999.9) or 1 (10,000 to 99,999).

**WET BULB**

**Range:** -7.6 to 158°F (-22 to 70°C).  
**Resolution:** 0.1°F (0.1°C).

**METER**

**Temperature Limits:** Operating: 32 to 122°F (0 to 50°C); Storage: -4 to 122°F (-20 to 50°C).  
**Humidity Limits:** Operating: <80% RH; Storage: <90% RH.  
**Display:** 1 x 1.8" (26 x 45 mm).  
**Serial Communications:** 9600 bps, 8 data bits, no parity.  
**Power Requirements:** (4) AAA 1.5 V alkaline batteries, included, user replaceable.  
**Battery Life:** 100 hours.  
**Vane Diameter:** 0.7" (18 mm).  
**Weight:** 7.41 oz (210 g).



# PORTABLE ULTRASONIC FLOWMETER KITS

Portable, Non-Invasive and Data Logging Option



PUB



PUF



The Series PUB & PUF Portable Ultrasonic Flowmeter Kits utilize the transit-time difference for measuring flow rates in pipes non-invasively. Units offer flow rate local display with analog and pulsed outputs. The Series PUF offers the same features plus data logging capability.

**FEATURES/BENEFITS**

- Non-invasive pipe measurement
- Compact and lightweight
- Incorporate the latest electronics and signal processing technologies realizing high performance and easy operation
- Ideal for on-the-go flow monitoring, capable of 20 hours continuous operation with built-in, rechargeable battery
- Easy to read graphic display with convenient backlight for visual comfort
- Efficient layout of the function keys for easy to use programming
- PUB features rugged carrying case with molded foam inserts
- PUF boasts an IP67 rated case to hold and protect all equipment conveniently

**APPLICATIONS**

- Water treatment
- Industrial systems
- Irrigation applications
- Treated water flow
- River water
- Sea water
- Potable water
- Demineralized water
- Glycol/water mix
- Hydraulic system
- Diesel oil
- Water use data logging

**KIT INCLUDES**

- Converter
- Set of transducers
- Transducer holders
- Set of transducer cables (6.56' (2 m))
- 4-20 mA communication cables
- 12 VDC power supply
- Ultrasonic coupling grease
- Set of chains
- Ruled guide rail
- Test block
- Carrying case

USA: California Proposition 65

⚠WARNING: Cancer and Reproductive Harm - www.P65Warnings.ca.gov

**MODEL 472A-1**

# DUAL INPUT THERMOCOUPLE THERMOMETER

Accepts J, K, T Thermocouples, Differential Temperature Indication

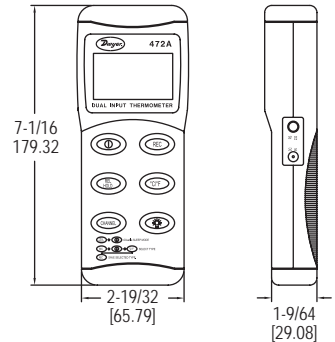
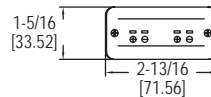

The Model 472A-1 Dual Input Thermocouple Thermometer precisely measures up to two temperature measurements simultaneously. The large LCD display shows both temperature inputs or one temperature input and the differential temperature. Any J, K, or T type thermocouple with a mini-jack connector can be used as an input. For viewing in poorly lit environments, the built-in back light brightens the display. A hold button allows the user to freeze temperature data displayed. Minimum and maximum readings can be recorded over a set time period. Model 472A-1 includes a hard carrying case, battery, and one K type thermocouple.

**SPECIFICATIONS**

**Inputs:** Type J, K, T thermocouples.  
**Power Requirements:** 9 V alkaline battery, installed non-functional, user replaceable.  
**Ranges:** J-type: -328 to 1400°F (-200 to 760°C); K-type: -328 to 2498°F (-200 to 1370°C); T-type: -328 to 734°F (-200 to 390°C).  
**Accuracy:** ±0.1% reading + 1.4°F (0.7°C).  
**Temperature Limits:** 32 to 122°F (0 to 50°C).  
**Humidity Limits (Non-Condensing):** 0 to 85% relative humidity.  
**Display:** Triple LCD display.  
**Resolution:** 0.1°C up to 500°C.  
**Weight:** 23.6 oz.

MODEL CHART	
Model	Description
472A-1	Digital Input Thermocouple Thermometer

OPTIONS	
Use order code:	Description
NISTCAL-TG	NIST traceable calibration certificate

ACCESSORIES	
Model	Description
472A-B	Rubber boot
1818-0074	Immersion probe
1818-0078	Penetration probe
1818-0082	Surface probe
1818-0085	Air duct probe
1718-0077	Remote probe handler

HANDHELD THERMOCOUPLES		
Model	Description	T/C Type
1718-0001	General Purpose Probe: Featuring a built-in handle with coiled cord and mini-plug, this general purpose probe can be used in liquids and air compatible gases. For use to 800°F.	J
1718-0002		K
1718-0014	Penetration Probe: Featuring a built-in handle with coiled cord and mini-plug, this probe is used for penetrating meat, plastic, rubber, asphalt, or other semi-soft materials.	J
1718-0015		K

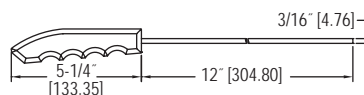

General purpose probe

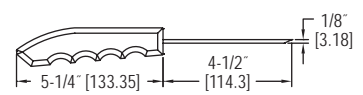

Penetration probe

**Dwyer**

SERIES LPTK

**GAS PRESSURE TEST KIT**

Convenient Kit Perfect For Testing LP and Natural Gas Controls

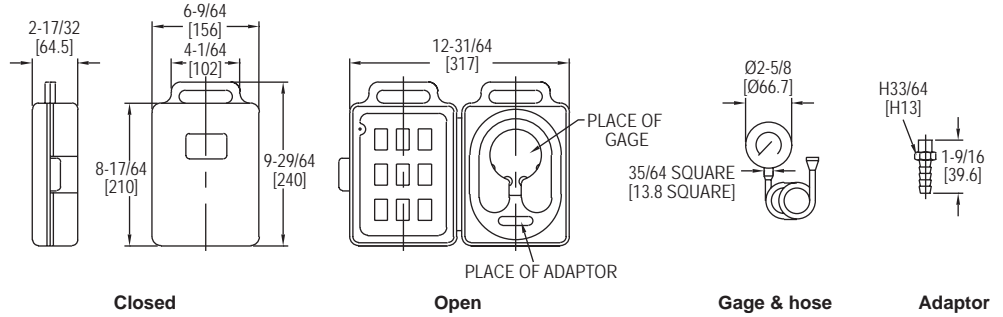

The **Series LPTK Gas Pressure Test Kit** is ideal for testing LP and natural gas lines and controls. The kit's gage shows if proper pressure is present or if a leak exists. Series LPTK is easier to use than a manometer and includes a sturdy case for added durability and safe handling.

**FEATURES/BENEFITS**

- Calibration screw on the back of the gage
- Simple interface for ease of use

**APPLICATIONS**

- Combustion gas supply monitoring and testing

**MODEL CHART**

Model	Range
LPTK-01	0 to 15 in w.c. & 0 to 8.6 oz/in <sup>2</sup>
LPTK-02	0 to 32 in w.c. & 0 to 18.5 oz/in <sup>2</sup>
LPTK-03	0 to 4 kPa & 0 to 40 mbar
LPTK-04	0 to 8 kPa & 0 to 80 mbar

**Note:** Consult factory for other range options.

**SPECIFICATIONS**

**Service:** Compatible gases.

**Wetted Materials:** Gage: brass, hose: rubber.

**Housing Materials:** Steel with black finish.

**Lens:** Polycarbonate.

**Accuracy:** ±3% FS.

**Pressure Limit:** 110% of range.

**Temperature Limits:** -40 to 150°F (-40 to 65°C).

**Size:** 2-1/2" (63 mm).

**Process Connections:** 1/8" NPT, brass hose barb.

**Case:** ABS plastic.

**Hose:** Rubber, 36" (91.4 cm).

**Tube Nipple:** Rubber.

**Weight:** 1.75 lb (0.8 kg).

# PORTABLE DIGITAL TACHOMETER

Contact or Photo Non-Contact Operation, Backlit LCD

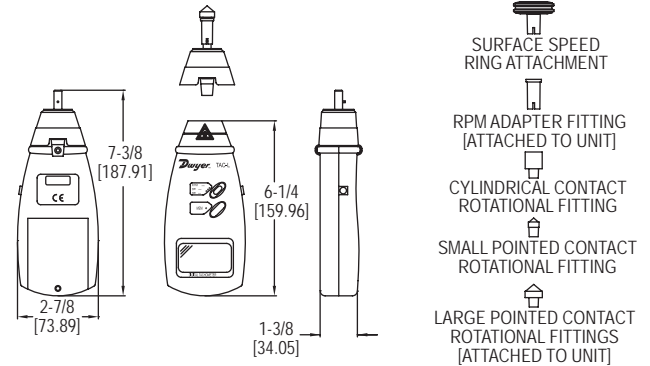

The **Model TAC-L Portable Digital Tachometer** measures rotational speed either by contacting a rotatable head to the shaft of the object or by using a photo sensor to detect the reflections from the laser. The housing is made of a strong, lightweight ABS plastic housing, which is designed to comfortably fit in the hand of the user. Supplied with this model are 3 contact rotational heads, a contact surface wheel, and a protective carrying case.

#### FEATURES/BENEFITS

- Non-contact operation can record from a distance of up to 20 inches
- Memory function recalls records since last power off
- Large backlit LCD for visibility in dark areas

#### APPLICATIONS

- HVAC fan motors
- Powder and bulk conveyor belts

#### SPECIFICATIONS

**Range:** Non-contact (RPM): 2.5 to 99,999 RPM; Contact (RPM): 0.5 to 19,999 RPM; Surface speed (m/min): 0.05 to 1999.9 m/min.  
**Accuracy:**  $\pm(0.05\% + 1 \text{ digit})$ .  
**Display:** Backlit LCD; 5 digits, 7 segments, 0.7" (1.8 cm) H.  
**Resolution:** Non-contact (RPM): 0.1 RPM (2.5 to 999.9 RPM), 1 RPM (1000 to 99,999 RPM); Contact (RPM): 0.1 RPM (0.5 to 999.9 RPM), 1 RPM (1000 to 19,999 RPM); Surface speed (m/min): 0.01 m/min (0.05 to 99.99 m/min), 0.1 m/min (100.0 to 1999.9 m/min).  
**Non-contact Measuring Distance Range:** 2 to 20" (5 to 50 cm).  
**Sampling Time:** 0.8 s.  
**Temperature Limits:** 32 to 122°F (0 to 50°C).  
**Power Requirements:** (4) 1.5 V AA alkaline batteries.  
**Weight:** 1.37 lb (.620 kg).

MODEL CHART	
Model	Description
TAC-L	Contact/non-contact digital tachometer

ACCESSORIES	
Model	Description
TAC-5	Reflective tape, 5' (1.5 m) roll, 1/2" (13 mm) wide

**Dwyer**

MODEL CSG

# CURRENT/VOLTAGE SIGNAL GENERATOR

Ramp Function, Large Numeric LCD Display

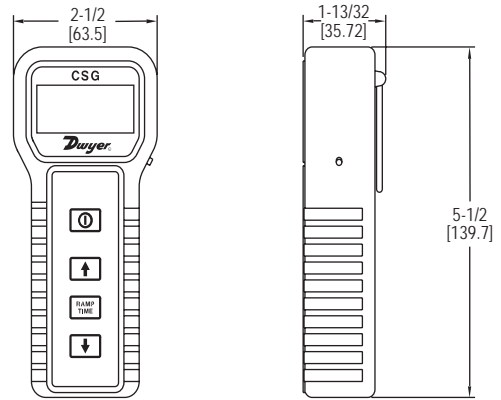

The **Model CSG Current/Voltage Signal Generator** generates a 0-10 VDC signal in increments of 1 V or a 0-20 mA signal in increments of 1 mA. The large LCD features a blue backlight for use in dimly lit areas. Model CSG continuously ramps the output using the user selected minimum, maximum, and ramp interval timing parameters.

**FEATURES/BENEFITS**

- Large backlit LCD for visibility in dark areas
- Timed ramp function
- Auto shut-off to conserve battery life

**APPLICATIONS**

- Troubleshooting transmitters and transducers
- Configuring panel meters

**SPECIFICATIONS**

**Impedance:** Voltage: 1000  $\Omega$  min; Current: 300  $\Omega$  max.  
**Output:** 0-20 mA (1 mA increments); 0-10 VDC (1 VDC increments).  
**Resolution:** 1 mA (current); 1 VDC (voltage).  
**Ramping Time Intervals:** 1 to 20 s (1 s increments).  
**Ambient Operating Temperature:** 32 to 122°F (0 to 50°C).  
**Power Requirements:** 9 V alkaline battery, included, user replaceable or 120 VAC (provided).  
**Auto Power Off:** 1 to 20 min.  
**Electrical Connections:** 6' (1.8 m) with alligator clips.  
**Weight:** 6 oz (170 g).

**MODEL CHART**

Model	Description
CSG	Current/voltage signal generator

**MODEL ASG**

# ANALOG SIGNAL GENERATOR

Ramp Function, Bar Graph LED, Selectable Auto Shut Off

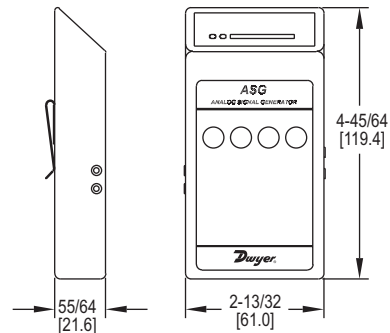

The **Model ASG Analog Signal Generator** generates a 0-10 VDC signal in increments of 1 V or a 4-20 mA signal in increments of 2 mA. An LED bar graph visually indicates the analog signal level. Model ASG will also continuously ramp to user defined maximum and minimum values with user defined ramp interval timing.

**FEATURES/BENEFITS**

- LED bar graph for visibility in dark areas
- Variable ramp function timing
- Auto shut-off to conserve battery life

**APPLICATIONS**

- Troubleshooting transmitters and transducer
- Calibrating transducers, displays, and other analog signal devices

**SPECIFICATIONS**

**Impedance:** Voltage: 1000  $\Omega$  min; Current: 300  $\Omega$  max.  
**Output:** 0-20 mA (2 mA increments); 0-10 VDC (1 VDC increments).  
**Resolution:** 2 mA (current), 1 VDC (voltage).  
**Ramping Time Intervals:** 2 to 20 sec (2 sec increments).  
**Ambient Operating Temperature:** 32 to 122°F (0 to 50°C).  
**Power Requirements:** 9 V alkaline battery, installed functional, user replaceable or 120 VAC (provided).  
**Auto Shutoff Times:** 2 to 20 min. (2 min. increments) (6 min. default).  
**Electrical Connections:** 6' (1.8 m) with alligator clips.  
**Weight:** 3.2 oz (without battery).

**MODEL CHART**

Model	Description
ASG	Analog signal generator



# HAND PUMP

Generates Pressures up to 45 psig (3 bar), Single Hand Operation

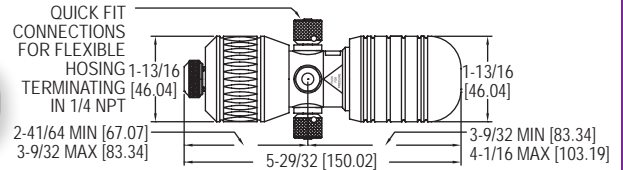

The **Model HP Hand Pump** provides a dual source of pneumatic pressure and vacuum for verifying the calibration of pressure instrumentation. Pump can generate pressures up to 45 psig (3 bar) and vacuum to -27 in Hg (-910 mbar). The compact pump is designed for portability and single hand operation. Model HP features a pressure relief valve and fine adjustment for control better than 0.0015 psi (0.1 mbar). Pump includes two 39" (1 m) hoses terminating in 1/4" female NPT connections and instruction manual.

**FEATURES/BENEFITS**

- Offers vacuum or positive pressure sourcing
- Compact and portable
- Integral relief valve for fine adjustment
- Reference gage recommendation: DPG-022

**APPLICATIONS**

- Test instrument calibration
- Pressure switch calibration
- Pressure transmitter calibration

MODEL CHART	
Model	Description
HP	Hand pump

ACCESSORIES	
Model	Description
HP-1K	Service kit
HP-1C	Hard case

USA: California Proposition 65

⚠WARNING: Cancer and Reproductive Harm - [www.P65Warnings.ca.gov](http://www.P65Warnings.ca.gov)

SERIES CHP

# PNEUMATIC HAND PUMP

Vacuum or Pressure, Ranges up to 100 psig

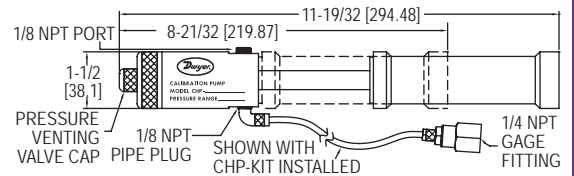

The **Series CHP Pneumatic Hand Pump** is the most dependable and rugged pump for applications up to 100 psi or 28.8 in Hg vacuum. The durable Acetel plastic and anodized aluminum construction prevents body heat transfer, resulting in drift-free, accurate readings. The Series CHP is equipped with oversized check valves in order to provide smooth and controlled operation. Dual O-Rings on all pistons ensure the pump to be leak-free. The unit includes a 2' L hose, 1/8" female NPT gage fitting, and 1/8" NPT pipe plug. An optional hose kit is available so that a tee is not required when connecting a sensor and a calibrator. The Series CHP is ideal for checking calibration of pressure or vacuum gages, switches, or transmitters.

**FEATURES/BENEFITS**

- Offers vacuum or positive pressure sourcing
- Compact and portable
- Integral relief valve for fine adjustment
- Reference gage recommendation: DPG-024

MODEL CHART	
Model	Description
CHP-P	Pressure calibration pump
CHP-V	Vacuum calibration pump

ACCESSORIES	
Model	Description
CHP-KIT	2' hose and NPT fitting

**APPLICATIONS**

- Test instrument calibration
- Pressure switch calibration
- Pressure transmitter calibration

MODEL A-396A

# CALIBRATION PUMP

Generates up to 72 psig, Integral Bleed Fitting

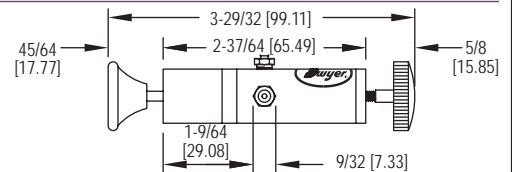

The **Model A-396A Calibration Pump** serves as pressure source to calibrate gages and transmitters or to set pressure switches. Use with manometer or other pressure standard. Includes volume adjuster enabling fine pressure control and bleed valve. Generates pressures from a fraction of an in w.c. to 72 psig (5 bar). Includes barbed fitting, tee connector and three 36" lengths of vinyl tubing.

**FEATURES/BENEFITS**

- Offers wide pressure sourcing capability
- Compact and portable
- Integral relief valve for fine adjustment
- Reference gage recommendation: DPG-024

MODEL CHART	
Model	Description
A-396A	Calibration pump

**APPLICATIONS**

- Test instrument calibration
- Pressure switch calibration
- Pressure transmitter calibration

MODEL A-350

# ASPIRATOR BULB

Single Hand Operation, Vacuum or Pressure



The **Model A-350 Aspirator Bulb** can be used to source pressure for calibration and leak checking tests. Simply squeeze the bulb after the tubing is connected to generate pressure. For applications such as our CO<sub>2</sub> indicator, the aspirator bulb can be squeezed before inserting the tubing to draw a vacuum to pull the smoke or air from a duct or stack into the gage.

**FEATURES/BENEFITS**

- Offers vacuum or positive pressure sourcing
- Compact and portable
- Most cost effective option
- Reference gage recommendation: Magnehelic 2010

MODEL CHART	
Model	Description
A-350	Aspirator bulb

**APPLICATIONS**

- Test instrument calibration
- Pressure switch calibration
- Pressure transmitter calibration
- Smoke leak testing



SERIES PCHP

# PNEUMATIC CALIBRATION HAND PUMP

Generates up to 600 psi (40 bar), Comfort Grip Handles

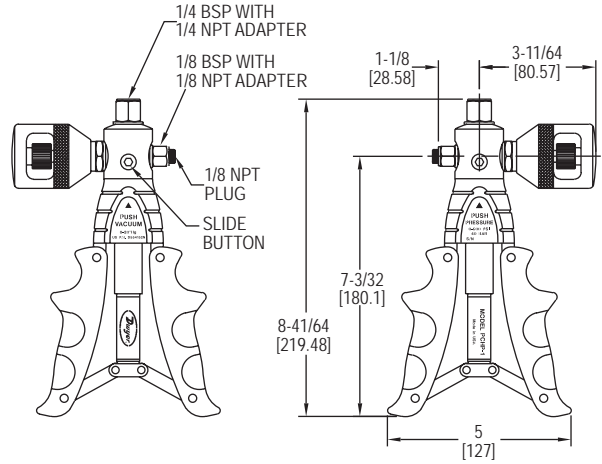

The **Series PCHP Pneumatic Calibration Hand Pump** sources pressure and vacuum to check calibration of gages, switches, transmitters, and recorders. The contoured cushion handles provide extra comfort while preventing the pump from sliding.

**FEATURES/BENEFITS**

- Oversized check valve maintain smooth operation
- Dual O-rings on pistons ensure no leaks

**APPLICATIONS**

- Instrument calibration
- Laboratories
- Production areas

**MODEL CHART**

Model	Description
PCHP-1	Pneumatic calibration hand pump
PCHP-1K	Pneumatic calibration hand pump with hose kit

**SPECIFICATIONS**

**Output Ranges:** -28 in Hg to 600 psi (-0.945 to 40 bar).  
**Process Connection:** 1/4" NPT/BSP.  
**Gage Connection:** 1/8" NPT/BSP.  
**Materials:** SS fittings, anodized aluminum housing, plastic/rubber handles, and nitrile O-rings.  
**Weight:** 2 lb (0.91 kg).

**ACCESSORIES**

Model	Description
PCHP-HK	High pressure hose

SERIES HCHP

# HYDRAULIC CALIBRATION HAND PUMP

Triple Filtration, Generates Pressure up to 10,000 psi (700 bar)

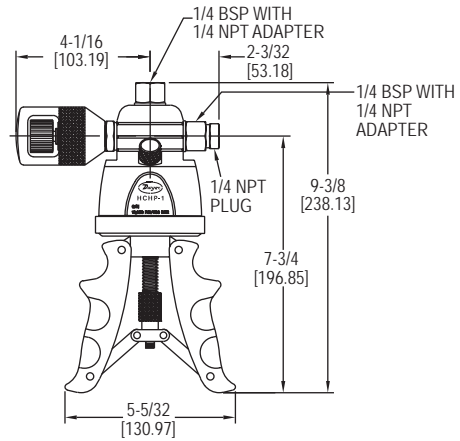

The **Series HCHP Hydraulic Calibration Hand Pump** utilizes a fully adjustable stroke control that allows for quick priming, easy pumping, and fast pressure generation up to 10,000 psi (700 bar). The ergonomically engineered handles provide extra comfort, while the triple filtration system ensures pump operation in spite of dirty conditions.

**FEATURES/BENEFITS**

- Oversized check valve maintain smooth operation
- Shatterproof reservoir and stainless steel construction guarantee no leaks

**APPLICATIONS**

- Instrument calibration
- Laboratories
- Production areas

**MODEL CHART**

Model	Description
HCHP-1	Calibration hand pump
HCHP-1K	Calibration hand pump with hose kit

**SPECIFICATIONS**

**Output Ranges:** 0 to 10,000 psi (0 to 700 bar).  
**Process Connection:** 1/4" NPT/BSP.  
**Gage Connection:** 1/4" NPT/BSP.  
**Materials:** SS, polyurethane, anodized hard-coat aluminum, PTFE, and nitrile.  
**Weight:** 3 lb (1.36 kg).

**ACCESSORIES**

Model	Description
HCHP-1F	Spare washer and filter kit

# LOW PRESSURE CALIBRATION PUMP

High Resolution for Calibrating Low Pressure Gages and Transmitters

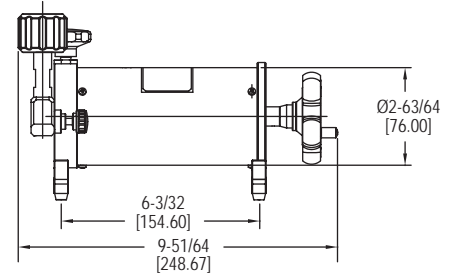
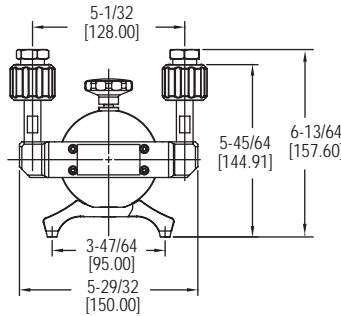

The **Model LPCP Low Pressure Calibration Pump** is a low air pressure source with the ability to easily adjust and stabilize. It is made up of quick connectors for fast instrument connect and disconnect.

**FEATURES/BENEFITS**

- Heat insulator between the cover and pressure chamber lessens the heat effect during micro-pressure calibration
- Highly stable adjustment

**APPLICATIONS**

- Instrument calibration
- Laboratories
- Production areas

MODEL CHART	
Model	Description
LPCP-2	Low pressure calibration pump

**SPECIFICATIONS**

**Media:** Air.  
**Output Ranges:** 5.8 psi (0.4 bar) vacuum to 5.8 psi (0.4 bar) positive pressure.  
**Pressure Resolution:** 0.01 Pa; 0.0001 mbar.  
**Process Connection:** M20\*1.5 or 1/4" NPT.  
**Gage Connection:** M20\*1.5 or 1/4" NPT.  
**Material:** Ram/adapters: 316 SS; Body: Steel/aluminum; Seals: Buna-N.  
**Weight:** 2.21 lb (1.0 kg).

**ACCESSORIES**

Model	Description
A-113A	Fitting kit. Includes (1) 1/4" NPT to 1/8" quick connect fitting, (1) 1/4" NPT to hose barb fitting, (1) hose barb fitting to 1/8" quick connect fitting, (2) 19.7" (0.5 m) length of blue 1/8" O.D. tubing, (2) 12" (0.3 m) length of clear 1/4" O.D. tubing

USA: California Proposition 65  
 ⚠️WARNING: Cancer and Reproductive Harm - www.P65Warnings.ca.gov

**SERIES BCHP**

# LOW PRESSURE CALIBRATION PUMP

Vacuum or Pressure, Generates up to 870 psi (60 bar)

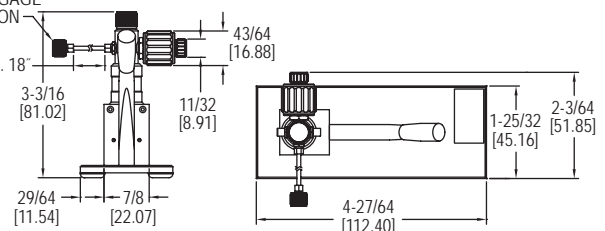
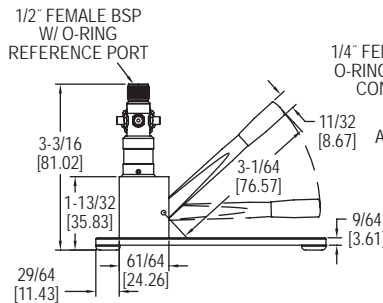

The **Series BCHP Low Pressure Calibration Pump** is able to generate pressure and vacuum for adjusting or calibrating pressure gages, transmitters, or switches. The pump is hand operated and has a pneumatic pressure range of -28 to 870 psi (-0.95 to 60 bar).

**FEATURES/BENEFITS**

- Dual pressure ports for ease of use
- Fine adjustment valve ensures precise measurements

**APPLICATIONS**

- Instrument calibration
- Laboratories
- Production areas

MODEL CHART	
Model	Description
BCHP-1	Calibration test pump
BCHP-KIT	Test pump with 1/4" NPT connections, fine volume adjustment tool and case

**SPECIFICATIONS**

**Media:** Air.  
**Output Ranges:** -28 in Hg to 870 psi (-0.95 to 60 bar).  
**Process Connections:** 1/4" female BSP.  
**Gage Connection:** 1/2" female BSP.  
**Materials:** Anodized aluminum, brass, and ABS.  
**Weight:** 8.4 lb (3.8 kg).

**ACCESSORIES**

Model	Description
A-BCHP-CASE	Case for BCHP-1
A-BCHP-NPT	1/4" BSP to 1/8" NPT, 1/4" NPT, 3/8" NPT and 1/2" NPT converter set for test connection
A-BCHP-VAT	Fine volume adjustment tool

USA: California Proposition 65  
 ⚠️WARNING: Cancer and Reproductive Harm - www.P65Warnings.ca.gov

# CIRCULAR CHART RECORDERS

## Single and Dual Pen, Rotation Speeds and Recording Times



LCR10



LCR20

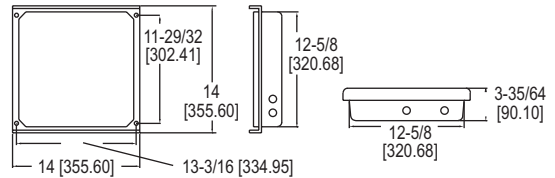

The **Series LCR10 & LCR20 Circular Chart Recorders** are two series of circular chart recorders with single and dual pen options. The LCR10 is a single pen recorder and the LCR20 is a dual pen. They can be easily programmed for any of six different thermocouple types, 100 ohm platinum DIN RTDs, or process inputs.

### FEATURES/BENEFITS

- Uses large 10" (254 mm) circular chart to easily read data
- Available with dual pen inputs

### APPLICATIONS

- Water level monitoring in water treatment
- Temperature/humidity in wood drying
- Room pressure monitoring in clean room applications

### MODEL CHART

Model	Rotation	Pen Inputs	Output
LCR10-101	Counter-clockwise	Single	No
LCR10-111	Counter-clockwise	Single	Yes
LCR20-101	Counter-clockwise	Dual	No
LCR20-111	Counter-clockwise	Dual	Yes

### SPECIFICATIONS

**Ranges:** Thermocouple: Type J, K, T, R, S, B; RTD: 100 Ω platinum DIN curve (0.00385 Ω per Ω per °C); Process: 0 to 5 VDC, 250 Ω impedance, 4 to 20 mA across 250 Ω.

**Chart Size:** 10" (254 mm).

**Accuracy:** ±0.5% of span (100 division span).

**Output Relay:** Form C (DPDT), 1A @ 240 VAC resistive.

**Chart Speed:** Programmable 4, 8, 12, 24, 48, 72, 168 hour rotation (168 hours=7 days).

**Ambient Operating Temperature/RH:** 32 to 140°F (0 to 60°C); 0-90% RH (non-condensing).

**Power Requirements:** 110/220 VAC ±10%.

**Battery Backup:** 9 V alkaline battery, installed functional, user replaceable.

**Power Consumption:** 15 VA max.

**Housing Material:** Fire retardant polyphenylene ether and polystyrene PPE & PS with acrylic window.

**Mounting:** ±20 degrees of vertical, ±10 degrees of horizontal.

**Weight:** 7 lb (3.2 kg).

**Agency Approvals:** CE.

### ACCESSORIES

Model	Description
LCR200	Chart paper, 0 to 200°F, 24 hour, CCW
LCR2007	Chart paper, 0 to 200°F, 7 day, CCW
LCR110C	Chart paper, 0 to 110°C, 24 hour, CCW
LCR-R	Red chart pens, package of 6
LCR-B	Blue chart pens, package of 6

### MODEL HTDL-20/30

# HIGH TEMPERATURE DATA LOGGER

## Submersible, Continuous Recording, User Replaceable Battery

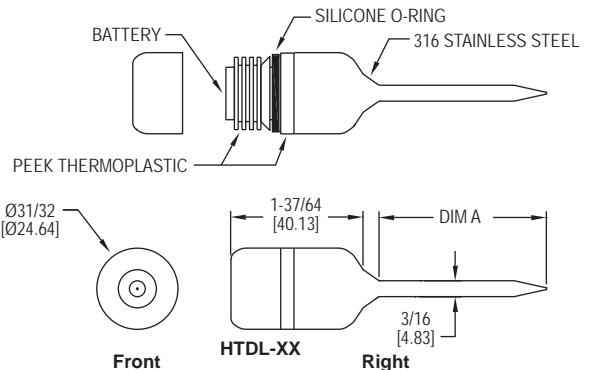

The **Model HTDL-20/30 High Temperature Data Logger** can measure temperatures up to 500°F (260°C) and record up to 32,700 measurements.

### FEATURES/BENEFITS

- Submersible and portable
- Temperature measurement up to 500°F
- Remote probe option for chamber or oven logging
- Delay startup timer

### APPLICATIONS

- Thermal testing
- Process monitoring or troubleshooting

### MODEL CHART

Model	Description
HTDL-20	High temperature data logger with 2" rigid probe
HTDL-30	High temperature data logger with 24" flexible probe

### SPECIFICATIONS

**Range:** -328 to 500°F (-200 to 260°C).

**Memory Size:** 32,700 readings.

**Accuracy:** 0.18°F (0.1°C) @ 68 to 284°F (20 to 140°C); 0.54°F (0.3°C) @ -4 to 67.98°F (-20 to 19.99°C).

**Resolution:** 0.02°F (0.01°C).

**Temperature Limits:** -4 to 284°F (-20 to 140°C).

**Sampling Method:** Stop on memory full or continuous recording.

**Sampling Rate:** Selectable from 1 s to 24 hrs.

**Computer Requirements:** Windows® Xp Sp3, Windows Vista®, Windows® 7 operating systems.

**Power Requirements:** 3.6 V 1/2 AA ER14250SM lithium metal battery, installed functional, user replaceable.

**Battery Life:** 1 year (approx).

**Interface:** Docking station and USB cable.

**Housing Material:** 316 SS.

**Weight:** 4.2 oz (120 g).

### ACCESSORIES

Model	Description
HTDL-DS	Docking station, software, manual and USB interface
ER1425S-HT	Replacement battery



# LCD PRESSURE DATA LOGGER

1/4" NPT Fitting, Records 262,143 Readings, Front Keypad

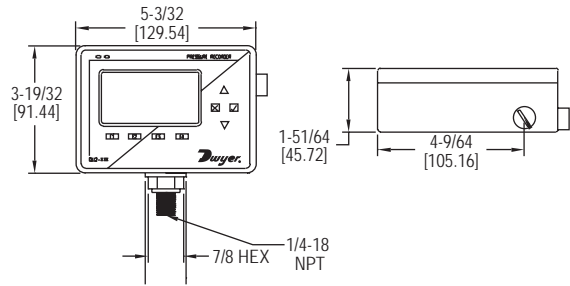

The **Series DLI2 LCD Pressure Data Logger** accurately records pressure and gives instant remote readings. The large, back-lit LCD and 8-button keypad provide convenient access to current data and recorder setup as well as memory and battery levels. The Series DLI2 can be ordered for absolute or gauge pressure measurements up to 5,000 psi. Using the keypad or software, measurements can be read in psi, in. Hg, mm Hg, bar, atm, Torr, Pa, kPa, or MPa. The large memory capacity allows over 260,000 readings to be stored. The easy to use DL700 software makes creating permanent records, performing data calculations, and graphing of data simple. The DLI2 can easily be started and stopped from a PC or delayed to start up to six months in advance. It can also stop recording at a specific time or after a certain number of readings have been taken.

**FEATURES/BENEFITS**

- Efficient data capture tool to review processes are running correctly or to analyze alarm and out-of-spec conditions
- Intuitive keypad interface allows easy set-up
- PC start and stopping allows centralized control of data collection

**APPLICATIONS**

- Building automation
- Clean room
- Operating rooms
- Process applications
- Labs
- Regulated environments

**MODEL CHART**

Model	Pressure Range	Model	Pressure Range
DLI2-A08	0 to 30 psia	DLI2-G13	0 to 300 psig
DLI2-G08	0 to 30 psig	DLI2-A14	0 to 500 psia
DLI2-A10	0 to 100 psia	DLI2-G14	0 to 500 psig
DLI2-G10	0 to 100 psig	DLI2-A15	0 to 1000 psia
DLI2-A13	0 to 300 psia	DLI2-A19	0 to 5000 psia

**SPECIFICATIONS**

**Ranges:** 0 to 30 psia (g), 0 to 100 psia (g), 0 to 300 psia (g), 0 to 500 psia (g), 0 to 1000 psia, and 0 to 5000 psia depending on the model.  
**Memory Size:** 262,143 readings.  
**Accuracy:** 2% FSR, 0.25% at 77°F (25°C) typical.  
**Resolution:** 0.002 psi (30 psi), 0.005 psi (100 psi), 0.02 psi (300 psi), 0.05 psi (500 and 1000 psi), and 0.2 psi (5000 psi) depending on model.  
**Sampling Method:** Stop on memory full or continuous recording.  
**Sampling Rate:** Selectable from 2 s to 12 hrs.  
**Computer Requirements:** Windows® 95, Windows® 98, Windows® 2000, Windows® ME, Windows NT®, or Windows® XP operating system, and one free USB port.  
**Power Requirements:** (6) AA alkaline batteries, installed functional, user replaceable.  
**Battery Life:** 1 yr (approx).  
**Interface:** USB port (interface cable required).  
**Housing Material:** Black anodized aluminum case.  
**Wetted Material:** 316L SS.  
**Enclosure Rating:** IP65.  
**Weight:** 40 oz (1134 g).

**ACCESSORIES**

Model	Description
DL700	Software, manual and USB interface cable
DLI-120	9 V power adapter (North America)

Windows®, Windows NT®, and Windows Vista® are registered trademarks of Microsoft Corporation.

**SERIES DLP**

# PRESSURE/TEMPERATURE DATA LOGGER

1/4" NPT Fitting, Up to 5000 psia

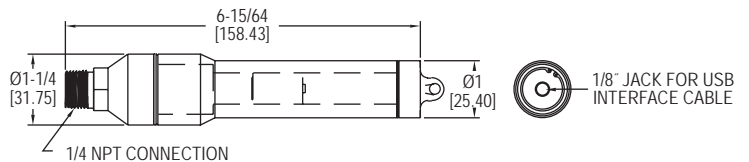

The **Series DLP Pressure/Temperature Data Logger** can record pressure and temperature. The 1/4" NPT fitting comes standard and allows the logger to be adapted to almost any pressure fitting. The internal temperature sensor provides accurate temperature measurements without the need of a separate temperature recorder, and many of the models provide a choice between measuring pressure in psia or psig. The DLP can easily be started and stopped from a PC or delayed to start up to six months in advance. The battery-powered data logger can store over 16,000 measurements per channel, and the easy to use DL700 software makes retrieving data simple.

**FEATURES/BENEFITS**

- Efficient data capture tool to review processes are running correctly or to analyze alarm and out-of-spec conditions
- Battery-powered reduces need to hard wire power allowing device to be used in a tool in a variety of in-and-out testing
- PC start and stopping allows centralized control of data collection

**APPLICATIONS**

- Building automation
- Clean room
- Operating rooms
- Process applications
- Labs
- Regulated environments

**MODEL CHART**

Model	Pressure Range	Model	Pressure Range
DLP-A08	0 to 30 psia	DLP-G13	0 to 300 psig
DLP-G08	0 to 30 psig	DLP-A14	0 to 500 psia
DLP-A10	0 to 100 psia	DLP-G14	0 to 500 psig
DLP-G10	0 to 100 psig	DLP-A15	0 to 1000 psia
DLP-A13	0 to 300 psia	DLP-A19	0 to 5000 psia

**SPECIFICATIONS**

**Range:** Temperature: -40 to 176°F (-40 to 80°C); Pressure: 0 to 30 psia(g), 0 to 100 psia(g), 0 to 300 psia(g), 0 to 500 psia(g), 0 to 1000 psia, and 0 to 5000 psia depending on the model.  
**Memory Size:** 16,383 readings per channel.  
**Accuracy:** Temperature: ±0.9°F (±0.5°C); Pressure: 2% FSR, 0.25% at 77°F (25°C) typical.  
**Resolution:** Temperature: 0.2°F (0.1°C); Pressure: 0.002 psia(g), 0.005 psia(g), 0.05 psia(g), 0.05 psia, and 0.2 psia depending on the model.  
**Sampling Method:** Stop on memory full.  
**Sampling Rate:** Selectable from 2 s to 12 hrs.  
**Computer Requirements:** Windows® 95, Windows® 98, Windows® 2000, Windows® ME, Windows NT®, and Windows® XP operating system, one free USB port.  
**Power Requirements:** 3.6 V TL2150 lithium metal battery, installed functional, user replaceable.  
**Battery Life:** 1 yr (approx).  
**Interface:** USB port (interface cable required).  
**Material:** 303 SS.  
**Weight:** 12 oz (340 g).

**ACCESSORIES**

Model	Description
DL700	Software, manual and USB interface cable
TL-2150	Replacement battery for Series DLP

Windows® is a registered trademark of Microsoft Corporation



MODEL GDL & GDL-T



# GRAPHICAL DISPLAY DATA LOGGER

Measure Temperature, Humidity and Dew Point, Instant Display

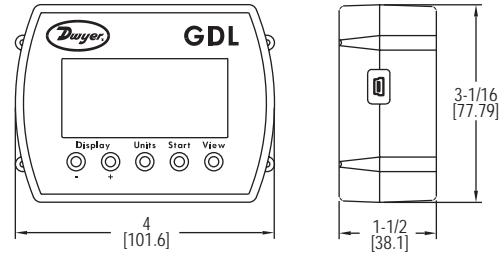

The **Model GDL Graphical Display Data Logger** can record and instantly display temperature, humidity, and dew point trends in a text or graphic format. The GDL has internal temperature and humidity sensors while the **Model GDL-T Graphical Display Data Logger** accepts up to 3 external temperature sensors. With the included Windows® based software, the user can select the sampling interval, high/low alarms, logging channels, and recording start time. Over 40,000 data points can be recorded and the measured data stays secure with a recording session counter and password-protected calibration.

**FEATURES/BENEFITS**

- Measurements displayed in text or graph
- Able to record over 40,000 data points and download them to a PC
- Includes logging summary with details of the sample rate and memory status

**APPLICATIONS**

- Greenhouses/florists
- Medical storage facilities
- Refrigeration systems
- Wine storage

**MODEL CHART**

Model	Description
GDL	Temperature/humidity data logger
GDL-T	Four temperature sensor data logger

**SPECIFICATIONS**

**Memory Size:** 43,344 temperature; 21,672 temperature, RH and dew point.  
**Temperature Range:** 15 to 150°F (-10 to 65°C).  
**Temperature Accuracy:** ±1°F (±0.5°C).  
**Temperature Resolution:** 0.01°F (0.01°C).  
**Humidity Range:** 0 to 99% RH.  
**Humidity Accuracy:** ±2% RH, from 10 to 90% RH.  
**Humidity Resolution:** 0.01% RH.  
**Sampling Method:** Stop on memory full or continuous recording.  
**Sampling Rate:** 1 s to 18 hrs, 1 s increments.  
**Computer Requirements:** Windows® 98 and above (software included).  
**Power Requirements:** (3) AA alkaline batteries, installed functional, user replaceable.  
**Alarms:** Programmable high/low.  
**Interface:** USB port (cable included).  
**Weight:** 7 oz (20 g).  
**Agency Approvals:** CE.

Windows® is a registered trademark of Microsoft Corporation

**SERIES BDL**

# BUTTON DATA LOGGER

Self-Powered, Compact Size, USB Interface

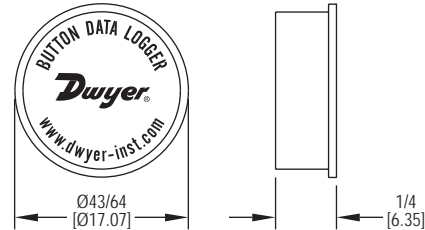

The **Series BDL Button Data Logger** records temperature and humidity in applications where size and cost effectiveness are vital. Housed in a compact stainless steel case, the BDL is durable in hostile environments, while also being able to be inserted in small items and packages. The Series BDL-K Logger Kit includes 2 buttons, 2 magnets, an interface cable, and a plastic button holder.

**FEATURES/BENEFITS**

- Compact to fit in small areas and durable to work in hostile environments
- Self-powered unit gives no need for external power supply
- Magnetic mounting for quicker installation

**APPLICATIONS**

- Food processing verification
- Pharmaceutical storage
- HVAC system testing and balancing
- Transportation of temperature sensitive goods

**ACCESSORIES**

Model	Description
DL500-LITE*	Lite version Windows® operating system software
DL500**	Full version Windows® operating system software key
BDL-SIL	Weatherproof silicone housing (5 pk)
BDL-WALL	Wall mounting bracket (5 pk)
BDL-CLIP	Plastic button holder (5 pk)
BDL-1	Temperature input data logger, no kit
BDL-2	Temperature/humidity input data logger, no kit

\*Free download from website \*\*Need lite version also

**SPECIFICATIONS**

**Range:** BDL-1: -40 to 185°F (-40 to 85°C); BDL-2: -4 to 185°F (-20 to 85°C), 0 to 100% RH.  
**Memory Size:** BDL-1: 2048 readings; BDL-2: 4096 temperature and 4096 humidity readings (low resolution), 2048 temperature and 2048 humidity readings (high resolution).  
**Accuracy:** BDL-1: ±1.5°F (±1°C) from -22 to 158°F (-30 to 70°C); BDL-2: ±0.9°F (±0.5°C) from 14 to 158°F (-10 to 70°C), ±5% RH.  
**Resolution:** BDL-1: 8 bit; BDL-2: 8 or 11 bit.  
**Sampling Method:** Stop on memory full or continuous recording.  
**Sampling Rate:** BDL-1: Selectable from 1 to 255 min.; BDL-2: Selectable from 1 s to 24 hrs.  
**Computer Requirements:** Windows® 98, Windows® 2000, Windows® ME, Windows NT®, Windows® XP, and Windows Vista® operating system with 16 MB RAM, one free USB port.  
**Power Requirements:** 3 V lithium metal battery, internal, non-replaceable.  
**Battery Life:** BDL-1: 10 years (approx); BDL-2: 5 years (approx).  
**Alarms:** Programmable high/low.  
**Interface:** USB port (cable included with kits).  
**Housing Material:** 305 SS.  
**Weight:** 0.14 oz (4 g).

**MODEL CHART**

Model	Input Type	Kit
BDL-K1	Temperature	Yes
BDL-K2	Temperature/humidity	Yes

Windows®, Windows NT®, and Windows Vista® are registered trademarks of Microsoft Corporation.

# COMPACT USB DATA LOGGER

Measure Temperature, Humidity, Dew Point, Current, Voltage, or Carbon Monoxide

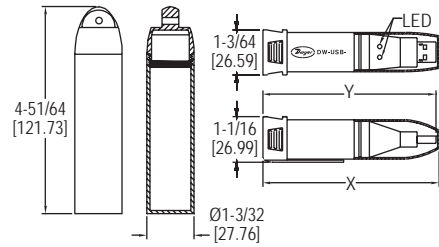

Model DW-USB-CASE Model DW-USB-X

Model	Overall Length (X)	Overall Length (Y)	Body/Clip	Cap	LED
DW-USB-1	3-55/64"	3-55/64"	Standard	Standard	Clear/red
DW-USB-2, -2-HA	4-1/16"	4-1/16"	Vented	Standard	Clear/clear
DW-USB-3	4-27/64"	4-27/64"	Standard	Black tip term block	Red/green
DW-USB-4	4-27/64"	4-27/64"	Standard	Blue tip term block	Red/green
DW-USB-5, -5-LR	4-59/64"	4-59/64"	Vented	Red tip CO sensor	Red/green
DW-USB-6	4-21/32"	4-21/32"	Standard	Standard	Red/green

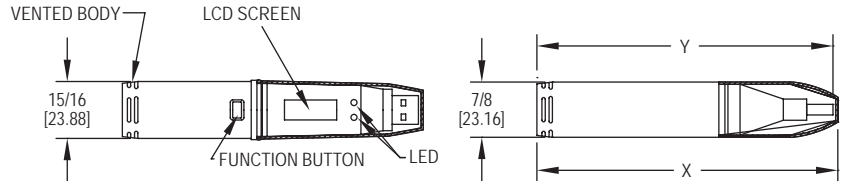

Model	Overall Length (X)	Overall Length (Y)	Body/Clip	Cap	LED
DW-USB-1-LCD	4-21/32"	4-41/64"	Standard	Transparent	Red/green
DW-USB-2-LCD	4-31/32"	4-57/64"	Vented	Transparent	Red/green
DW-USB-2-HA-LCD	4-31/32"	4-57/64"	Vented	Transparent	Red/green
DW-USB-6-LCD	5-19/64"	5-15/64"	Plug in bottom	Transparent	Red/green

The **Series DW-USB Compact USB Data Logger** allows users to monitor temperature, humidity, dew point, voltage, current, or carbon monoxide almost anywhere, and then download stored data by simply plugging the module directly into a PC's USB port. The compact housing can resist moisture up to IP67 when the protective cap is attached, and has built in LED's to indicate an alarm has been met or the battery is low. Users can set the sampling rate, start time, high/low alarms, and temperature unit via software available for free download from our website.

### FEATURES/BENEFITS

- Meets IP67 standards when the protective cap is fitted
- All in one unit plugs into PC with no cable required
- LED status indicators for visual confirmation
- Optional integral LCD display for local indication

### APPLICATIONS

- Calibration labs
- Environmental chambers
- Pharmaceutical plants
- Storage warehouses

### SPECIFICATIONS

**Memory Size:** 16,382 temperature; 16,382 each temperature and RH; 32,764 readings for voltage, current, and thermocouple; and 32,510 for carbon monoxide.  
**Sampling Mode:** Stop on memory full.  
**Sampling Rate:** Selectable from 10 s to 12 hr (temperature and RH models); 1 s to 12 hr (voltage, current, and thermocouple models); 10 s to 5 m (CO models).

**Computer Requirements:** Compatible with Windows® 7, Windows® 8 and Windows® 10.  
**Power Requirements:** 3.6 V 1/2 AA lithium metal battery, included, user replaceable.  
**Housing:** ABS plastic blend.  
**Alarms:** Programmable high/low.  
**Interface:** USB port.  
**Weight:** 1.5 oz (43 g).

### ACCESSORIES

Model	Description
DW-USB-CASE	Waterproof case for DW-USB-1
1818-0074	Immersion temperature probe
1818-0078	Penetration temperature probe
1818-0082	Surface temperature probe
1818-0085	Air duct temperature probe
1718-0077	Remote temperature probe handle

### MODEL CHART

Model	Sensor Type	Range	Accuracy	Resolution
DW-USB-1	Temperature	-31 to 176°F (-35 to 80°C)	±2°F (±1°C)	1°F (0.5°C)
DW-USB-2	Temperature/humidity/dew point	-31 to 176°F (-35 to 80°C), 0 to 100% RH	±4°F (2°C), ±3% RH from 20 to 80% RH, ±5% RH	1°F (0.5°C), 0.5% RH
DW-USB-2-HA	Temperature/humidity/dew point	-31 to 176°F (-35 to 80°C), 0 to 100% RH	±3°F (1.5°C), ±2% RH from 20 to 80% RH, ±4% RH	1°F (0.5°C), 0.5% RH
DW-USB-3	Voltage	0 to 30 VDC	±1%	50 mVDC
DW-USB-4	Current	4 to 20 mA	±1%	0.05 mA
DW-USB-5	Carbon monoxide	0 to 1000 ppm	±6% of reading	0.5 ppm
DW-USB-5-LR	Carbon monoxide	0 to 300 ppm	±4% of reading	0.5 ppm
DW-USB-6	External thermocouple	With supplied probe: 32 to 752°F (0 to 400°C) J-type: -202 to 1652°F (-130 to 900°C); K-type: -328 to 2372°F (-200 to 1300°C); T-type: -328 to 662°F (-200 to 350°C)	±2°F (1°C) (for data logger only)	1°F (0.5°C)
DW-USB-1-LCD	Temperature	-31 to 176°F (-30 to 80°C)	±3°F (1.5°C)	1°F (0.5°C)
DW-USB-2-LCD	Temperature/humidity/dew point	-31 to 176°F (-35 to 80°C), 0 to 100% RH	±4°F (2°C), ±3% RH from 20 to 80% RH, ±5% RH	1°F (0.5°C), 0.5% RH
DW-USB-2-HA-LCD	Temperature/humidity/dew point	-31 to 176°F (-35 to 80°C), 0 to 100% RH	±3°F (1.5°C), ±2% RH from 20 to 80% RH, ±4% RH	1°F (0.5°C), 0.5% RH
DW-USB-6-LCD	External Thermocouple	With supplied probe: 32 to 752°F (0 to 400°C) J-type: -202 to 1652°F (-130 to 900°C) K-type: -328 to 2372°F (-200 to 1300°C) T-type: -328 to 662°F (-200 to 350°C)	±2°F (1°C) (for data logger only)	1°F (0.5°C)

Windows® is a registered trademark of Microsoft Corporation.

**Dwyer**

MODEL DW-DATAPAD

# HANDHELD PORTABLE DATA VIEWER

Works With DW-USB Data Logger

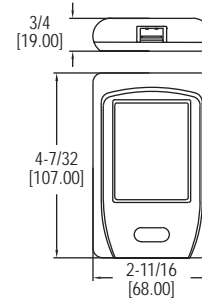

The **Model DW-DATAPAD Handheld Portable Data Viewer** configures and reads data from up to 500 DW-USB data loggers and utilizes a 2.8" full color TFT touch screen display. Data can be displayed as a trend graph or a statistical summary, and can also be transferred to a computer using the provided cable and Windows® based software. Model DW-DATAPAD features a rechargeable lithium battery and has an average life of 5 to 8 hours under constant use.

**FEATURES/BENEFITS**

- 2.8" full color TFT touch screen simplifies navigation through configuration menus
- Rechargeable lithium battery has a 5 to 8 hour life when constantly used

**APPLICATIONS**

- Calibration labs
- Environmental chambers
- Pharmaceutical plants
- Storage warehouses

**MODEL CHART**

Model	Description
DW-DATAPAD	Handheld portable data viewer for Dwyer USB data loggers

**SPECIFICATIONS**

**Data Recording Capacity:** Internal flash memory, greater than 8.5 million readings.  
**Battery life:** 5 to 8 hours (constant use).  
**Operating Temperature Range:** 0 to 50°C (32 to 122°F).  
**Power Requirements:** CA374170 lithium ion battery, installed functional, factory replaceable.  
**Display:** 2.8" full color TFT touch screen LCD display.  
**Resolution:** 240 X 320.  
**Interface:** Touch screen and single front-panel push-button power switch.  
**Connections:** 1 USB type A socket (top of unit) for data logger connection. 1 micro-USB (bottom of unit) for connection of unit to PC via supplied USB cable.  
**Compatible Data Loggers:** DW-USB-1, DW-USB-1-HT, DW-USB-1-LCD, DW-USB-2, DW-USB-2-HA, DW-USB-2-HA-LCD, DW-USB-2-LCD, DW-USB-6, DW-USB-6-LCD, and DW-USB-LITE.  
**Weight:** 3.9 oz (111 kg).  
**Agency Approvals:** CE.

Windows® is a registered trademark of Microsoft Corporation.

**SERIES DW-WIFI**

# WIRELESS WI-FI DATA LOGGER

Measures Temperature/Humidity, Integral LCD

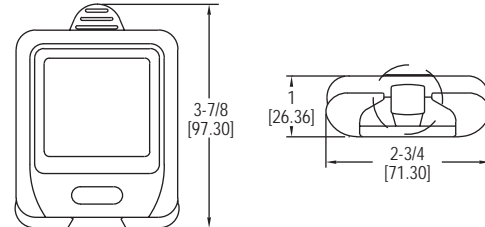

The **Series DW-WIFI Wireless Wi-Fi Data Logger** measures and records up to 1,000,000 temperature and/or humidity readings and shares the data with any PC or server on the same Wi-Fi network. If the Wi-Fi connection is lost, the sensor will continue to store any records until it can regain communication with the network. The downloadable Windows® based software allows users to set high/low alarms, sampling rate, and the temperature scale.

**FEATURES/BENEFITS**

- Continues to record values even if Wi-Fi connection is lost
- Able to record up to 1,000,000 data points, which can be downloaded to a PC
- Large LCD allows users to view data directly from unit

**APPLICATIONS**

- Building/site monitoring
- Environment monitoring
- Weather monitoring

**MODEL CHART**

Model	Input	Range	Accuracy (Typ.)	Display Resolution
DW-WIFI-T	Internal temperature	-4 to 140°F (-20 to 60°C)	±1.0°F (±0.5°C) @ 14 to 122°F (-10 to 50°C)	0.1°F (0.1°C)
DW-WIFI-TH	Internal temperature/humidity	-4 to 140°F (-20 to 60°C), 0 to 100% RH	±0.6°F (±0.3°C) @ 41 to 140°F (5 to 60°C) ±2.5% RH @ 20 to 80% RH	0.5°F (0.5°C) 1.0% RH
DW-WIFI-TP	Remote temperature probe	-40 to 257°F (-40 to 125°C)	±1.2°F (±0.6°C) @ 14 to 158°F (-10 to 70°C)	0.1°F (0.1°C)
DW-WIFI-TC	Remote thermocouple	-454 to 2372°F (-270 to 1300°C)*	±3.0°F (1.5°C)	0.1°F (0.1°C)
DW-WIFI-T-HA	Internal temperature	-4 to 140°F (-20 to 60°C)	±0.2°F (±0.1°C) @ 14 to 140°F (-10 to 60°C)	0.1°F (0.01°C)
DW-WIFI-TH-HA	Internal temperature/humidity	-4 to 140°F (-20 to 60°C), 0 to 100% RH	±0.4°F (±0.2°C) @ 41 to 140°F (5 to 60°C) ±2.5% RH @ 10 to 90% RH	0.5°F (0.5°C) 1.0% RH
DW-WIFI-TP-HA	Remote temperature probe	-40 to 257°F (-40 to 125°C)	±0.2°F (±0.1°C) @ 14 to 158°F (-10 to 70°C)	0.01°F (0.01°C)

\*Probe dependent

**SPECIFICATIONS**

**Memory Size:** 1,000,000 readings; 500,000 each for DW-WIFI-TH(-HA).  
**Sampling Mode:** Continuous recording.  
**Sampling Rate:** Selectable from 10 s to 12 hr.  
**Transmission Rate:** Selectable from 1 min to 24 hr.  
**Temperature Limits:** -4 to 140°F (-20 to 60°C).  
**Power Requirements:** 3.7 V lithium ion battery, installed functional, factory replaceable (cable for charging included).  
**Alarms:** Programmable high/low.  
**Interface:** Wi-Fi connection.  
**Probe Length:** DW-WIFI-TP: 11.8" (30 cm); DW-WIFI-TC: 59" (150 cm).  
**Weight:** 7.2 oz (204 g).



**SELECTION GUIDE**  
pages 206-207

**TYPICAL APPLICATIONS**  
pages 208-209



**Flow Sensors**  
pages 210-215



**Fume Hood Monitors**  
page 216



**Air Flow Switches**  
pages 216-217



**Air Velocity Transmitters**  
pages 218-220



**Humidity Switches**  
page 221



**Humidity/Temperature Transmitters**  
pages 222-227

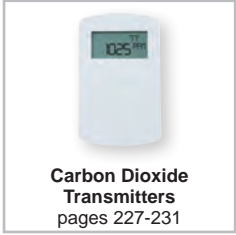

**Carbon Dioxide Transmitters**  
pages 227-231



**Gas Sensing Transmitters**  
pages 232-233



**Occupancy Sensors**  
page 234

## FEATURED PRODUCTS

### AIR VELOCITY TRANSMITTER

SERIES AVUL | page 218



- Field selectable ranges from 0-4000 FPM (0-20 m/s)
- 3% or 5% accuracy
- Optional BACnet MS/TP or Modbus® Communication Protocol

### CARBON MONOXIDE TRANSMITTER AND SWITCH

SERIES CMS300 | page 233







- Field selectable current or voltage analog outputs
- Integral SPDT relay contact for low or high alarm
- Jumper selectable alarm set points of 25, 60, or 150 PPM

## AIR VELOCITY Transmitters

				
<b>SERIES</b>	<b>AVUL</b> - page 218	<b>641</b> - page 219	<b>641RM</b> - page 220	<b>641B</b> - page 220
<b>Service</b>	Clean air	Clean air	Clean air	Clean air
<b>Range</b>	1,000 to 4,000 FPM (5 to 20 MPS)	250 to 15000 FPM (1.25 to 75 MPS)	250 to 2000 FPM (1.25 to 10 MPS)	250 to 2000 FPM (1.25 to 10 MPS)
<b>Accuracy</b>	±3 or 5% of reading	±3 to 4% FS	±3 to 4% FS	±5 to 6% FS
<b>Mounting</b>	Duct mount	Duct mount	Remote mount	Duct mount
<b>Probe Length</b>	7-41/64"	6 to 36" (152 to 915 mm)	6 to 36" (152 to 915 mm)	4-1/4" (108 mm)
<b>Output</b>	4-20 mA, 0-5 VDC, or 0-10 VDC selectable	4-20 mA	4-20 mA	4-20 mA
<b>Display</b>	Optional LCD	Optional LED	Optional LED	Optional LED
<b>Process Temperature Limits</b>	32 to 122°F (0 to 50°C)	-40 to 212°F (-40 to 100°C)	-40 to 212°F (-40 to 100°C)	-40 to 176°F (-40 to 80°C)

## HUMIDITY & HUMIDITY/TEMPERATURE Transmitters

				
<b>SERIES</b>	<b>RHP-E/N</b> - page 222	<b>RHP</b> - page 224	<b>RHP with Shield</b> - page 225	<b>WHT</b> - page 225
<b>Service</b>	Room	Duct or outdoor	Outdoor	Room or outdoor
<b>Accuracy</b>	±2, 3, or 5% FS	±2, 3, or 5% FS	±2, 3, or 5% FS	±3% FS
<b>RH Output</b>	4-20 mA, 0-5 VDC, 0-10 VDC	4-20 mA, 0-5 VDC, 0-10 VDC	4-20 mA, 0-5 VDC, 0-10 VDC	4-20 mA, 0-5 VDC, 0-10 VDC
<b>Temperature Output Options</b>	None, passive sensor, 4-20 mA, 0-5 VDC, 0-10 VDC	None, passive sensor, 4-20 mA, 0-5 VDC, 0-10 VDC	None, passive sensor, 4-20 mA, 0-5 VDC, 0-10 VDC	None, passive sensor, 4-20 mA, 0-5 VDC, 0-10 VDC
<b>Display</b>	Optional LCD	None	None	None

These Selection Guides are for quick comparison of similar products. Please refer to the catalog page number referenced for complete product information and specifications.

# CARBON MONOXIDE Sensors

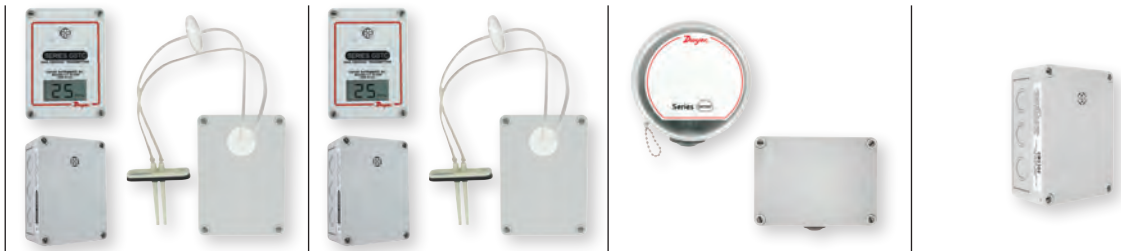

SERIES	GSTA - page 232	GSTC - page 232	CMT200 - page 233	CMS300 - page 233
Service	Carbon monoxide or nitrogen dioxide	Carbon monoxide or nitrogen dioxide	Carbon monoxide	Carbon monoxide
Range	0 to 500 PPM CO or 0 to 10 PPM NO <sub>2</sub>	0 to 500 PPM CO or 0 to 10 PPM NO <sub>2</sub>	0 to 200 PPM CO	0 to 300 PPM CO
Housing	Space or duct	Space or duct	Space	Space
Output	4-20 mA, 0-5 VDC, 1-5 VDC, 0-10 VDC, 2-10 VDC	BACnet MS/TP, Modbus <sup>®</sup> RTU, Modbus <sup>®</sup> ASCII	4-20 mA, 2-10 VDC	4-20 mA, 2-10 VDC
Relay	None	N/A	N/A	(1) SPDT
Display	Optional LCD	Optional LCD	N/A	N/A

# HUMIDITY & HUMIDITY/TEMPERATURE Transmitters

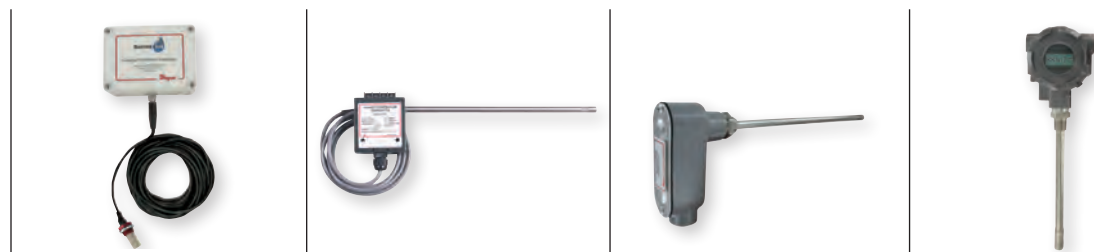

SERIES	RH-R - page 226	657 - page 226	657C - page 226	HHT - page 227
Service	Duct or process	Duct	Duct	Room or outdoor
Accuracy	±2% FS	±2% FS	±2% FS	±2% FS
RH Output	4-20 mA	4-20 mA	4-20 mA	4-20 mA
Temperature Output	None, 4-20 mA	4-20 mA	4-20 mA	None, 4-20 mA
Options				
Display	None	None	None	Optional LCD

Modbus<sup>®</sup> is a registered trademark of Schneider Automation, Inc.

These Selection Guides are for quick comparison of similar products. Please refer to the catalog page number referenced for complete product information and specifications.

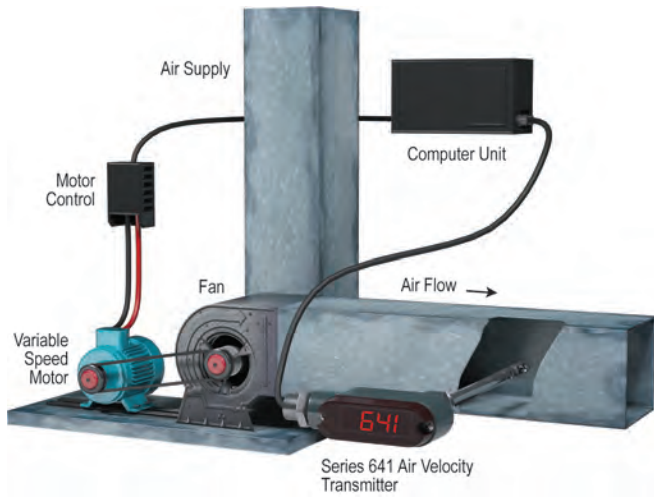

**Dwyer® transmitter signals precise air velocity adjustments to computer-controlled variable-speed fan motor.**

In variable air volume (VAV) HVAC systems, a computerized control provides precise adjustment of air volume to meet changing system needs with maximum energy efficiency. The Dwyer® Series 641 has an optional LED display for local indication of air flow. The LED display provides a quick, visual acknowledgment of proper system performance. The computer reacts to any change in velocity by signaling the motor control to increase or decrease fan speed to maintain the required velocity. The computer, taking inputs from other ambient condition sensors, will establish a new required air velocity and signal an appropriate adjustment in fan speed.



**Automate your garage ventilation.**

Carbon monoxide and Nitrogen Dioxide are by-products released in the exhaust from gasoline and diesel powered vehicles. These gases can build up in parking garages and loading dock areas where vehicles are concentrated, creating a potentially harmful environment. Ventilation is required to purge these gasses, but running fans non-stop increases building operating costs. The Dwyer® Series GSTA and GSTC can help to offer a more efficient solution to garage ventilation by transmitting CO or NO<sub>2</sub> concentrations via an analog output signal or digital BACnet/Modbus® communication. This signal is sent to the Building Management System and the ventilation processes can then be automated to run only when the gases are present in dangerous concentrations. For stand-alone systems, the analog signal can be sent to a Series SCD process controller to provide a closed loop control system running the ventilation fans. Using the Dwyer® Series GSTA or GSTC transmitter, ventilation will occur only when needed, reducing the cost of maintaining air quality standards.

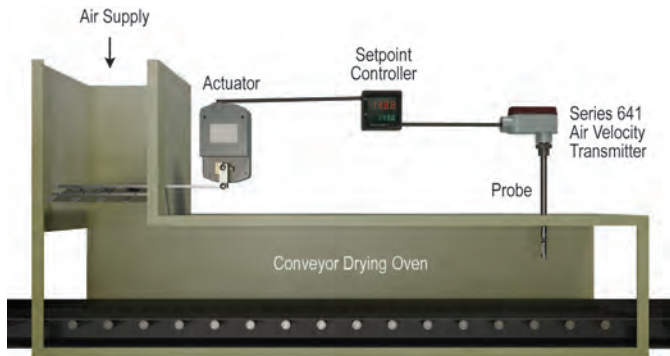

**Air velocity transmitter controls drying oven air flow.**

The flow of heated air is held to a constant predetermined velocity in this carefully controlled low temperature process drying oven. The constant temperature air supply is modulated by a set of inlet louvers operated by a servo-driven actuator. A Dwyer® Series 641 Air Velocity Transmitter has an optional LED display for local indication of air flow. The LED display provides a quick, visual acknowledgment of proper system performance. The controller compares the Series 641's signal to the set point in the controller and continuously signals appropriate louver adjustments to the actuator.



**Eliminate the need for Pitot tubes, orifice plates, differential pressure sensors and temperature sensors with a Series AVUL.**

Installing air velocity measurement systems can be a burdensome process – specifying Pitot tubes, static pressure tips, orifice plates, differential pressure transmitters, etc. Dwyer offers the Series AVUL Air Velocity Transmitter to consolidate these components into one convenient instrument. The Series AVUL can be easily installed into the duct or air stream to accurately measure air flow while providing local indication as well as linear analog output. Microprocessor-based technology ensures accurate, repeatable results. The Series AVUL combines these features for simple, reliable airflow measurement without the problems associated with complex, traditional systems.



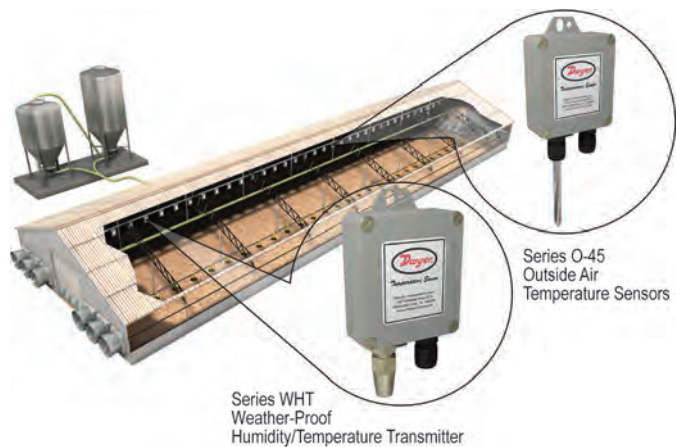

**Temperature and humidity measurements used to optimize the growth of hogs and poultry.**

The Dwyer® Series WHT Humidity Transmitter and Series O-4 Temperature Sensors are used to control the environmental conditions on hog and poultry farms. The amount the animals eat is linked to how comfortable the environmental conditions are. Thus the temperature, humidity, amount of light and other ambient conditions are tightly controlled to insure optimal animal growth.

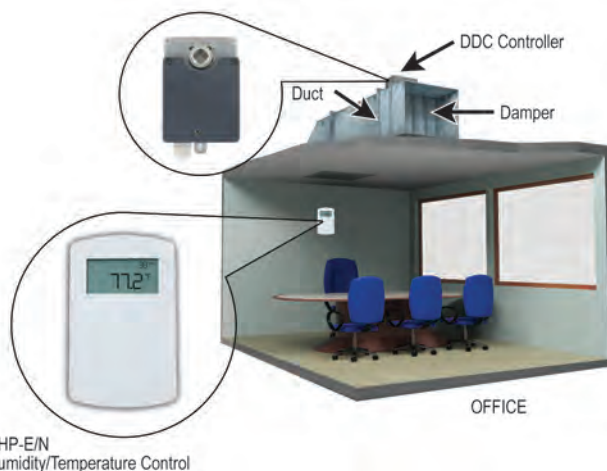

**Accurately measure and control the humidity and temperature in office buildings.**

The Dwyer® Series RHP-E/N wall mount humidity and temperature transmitter can be combined with a DDC controller and a damper to provide comfortable working conditions in an office building. The amount of air flow entering the room is varied based on the temperature and humidity readings of the Series RHP-E/N. The compact size and mounting configuration allow this transmitter to be discretely mounted in any room.

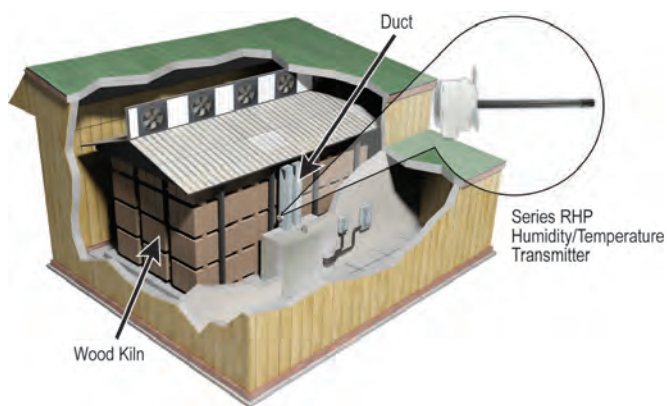

**Greatly reduce the time it takes to dry wood.**

The Dwyer® Series RHP monitors the humidity and temperature in the return air ducts in wood dehumidification rooms. Large fans are used to circulate air across the room. As dry conditioned air moves across the wood, it absorbs moisture from the wood. The humidity level of the air in the return air duct is representative of how much moisture is in the wood. When the humidity in the duct declines, it signifies that less dry conditioned air is needed to be supplied to the room.



**Demand control ventilation.**

Since the number of people in a conference room or classroom varies throughout the day, the amount of conditioned air needed to properly ventilate the room varies as well. As the number of people in a room increase, the concentration of carbon dioxide in the room will also increase. The Dwyer® Series CDT, CDTR, CDTV, and CDTA carbon dioxide transmitters measures the amount of carbon dioxide that is emitted so that the VAV control system can supply enough fresh air into the space to return the concentration of carbon dioxide in the room to normal levels.

Typical Applications



# DUCT MOUNTED AIRFLOW MEASUREMENT STATIONS

Rectangular, Oval or Circular Configurations

MODEL CHART - SERIES FLST RECTANGULAR OR OVAL															
Size	8"	10"	12"	14"	16"	18"	20"	22"	24"	26"	28"	30"	32"	34"	36"
8"	X	X	X	X	X	X	X	X	X	X	X	X	X	X	X
10"		X	X	X	X	X	X	X	X	X	X	X	X	X	X
12"			X	X	X	X	X	X	X	X	X	X	X	X	X
14"				X	X	X	X	X	X	X	X	X	X	X	X
16"					X	X	X	X	X	X	X	X	X	X	X
18"						X	X	X	X	X	X	X	X	X	X
20"							X	X	X	X	X	X	X	X	X
22"								X	X	X	X	X	X	X	X
24"									X	X	X	X	X	X	X
26"										X	X	X	X	X	X
28"											X	X	X	X	X
30"												X	X	X	X
32"													X	X	X
34"														X	X
36"															X

Note: When ordering rectangular or oval flow stations, pressure taps will always be located on the longer of the two dimensions.

MODEL CHART - SERIES FLST RECTANGULAR OR OVAL																
Size	40"	44"	48"	52"	56"	60"	66"	72"	78"	84"	90"	96"	102"	108"	114"	120"
8"	X	X	X	X	X	X	X	X	X	X	X	X	X			
10"	X	X	X	X	X	X	X	X	X	X	X	X	X			
12"	X	X	X	X	X	X	X	X	X	X	X	X	X	X		
14"	X	X	X	X	X	X	X	X	X	X	X	X	X	X	X	
16"	X	X	X	X	X	X	X	X	X	X	X	X	X	X	X	X
18"	X	X	X	X	X	X	X	X	X	X	X	X	X	X	X	X
20"	X	X	X	X	X	X	X	X	X	X	X	X	X	X	X	X
22"	X	X	X	X	X	X	X	X	X	X	X	X	X	X	X	X
24"	X	X	X	X	X	X	X	X	X	X	X	X	X	X	X	X
26"	X	X	X	X	X	X	X	X	X	X	X	X	X	X	X	X
28"	X	X	X	X	X	X	X	X	X	X	X	X	X	X	X	X
30"	X	X	X	X	X	X	X	X	X	X	X	X	X	X	X	X
32"	X	X	X	X	X	X	X	X	X	X	X	X	X	X	X	X
34"	X	X	X	X	X	X	X	X	X	X	X	X	X	X	X	X
36"	X	X	X	X	X	X	X	X	X	X	X	X	X	X	X	X
40"	X	X	X	X	X	X	X	X	X	X	X	X	X	X	X	X
44"		X	X	X	X	X	X	X	X	X	X	X	X	X	X	X
48"			X	X	X	X	X	X	X	X	X	X	X	X	X	X
52"				X	X	X	X	X	X	X	X	X	X	X	X	X
56"					X	X	X	X	X	X	X	X	X	X	X	X
60"						X	X	X	X	X	X	X	X	X	X	X
66"							X	X	X	X	X	X	X	X	X	X
72"								X	X	X	X	X	X	X	X	X
78"									X	X	X	X	X	X	X	X
84"										X	X	X	X	X	X	X
90"											X	X	X	X	X	X
96"												X	X	X	X	X
102"													X	X	X	X
108"														X	X	X
114"															X	X
120"																X

Note: When ordering rectangular or oval flow stations, pressure taps will always be located on the longer of the two dimensions.

OPTIONS	
To order add suffix:	Description
-IM	Internal pressure connections (rectangular stations only)
-F	Flange (oval stations only)
-SS1	316 SS elements with 16 GA galvanized casing
-SS2	316 SS elements with 16 GA 304 SS casing
-SS3	316 SS elements with 16 GA 316 SS casing

MODEL CHART - SERIES FLST CIRCULAR														
Size	8"	10"	12"	14"	16"	18"	20"	22"	24"	26"	28"	32"	36"	40"
	X	X	X	X	X	X	X	X	X	X	X	X	X	X
Size	44"	48"	54"	60"	66"	72"	78"	84"	90"	96"	102"	108"	114"	120"
	X	X	X	X	X	X	X	X	X	X	X	X	X	X





# DUCT MOUNTED AIRFLOW MEASUREMENT STATION

Integral Flow Straightener, Ideal for Turbulent Measuring Conditions

MODEL CHART - SERIES STRA RECTANGULAR OR OVAL															
Size	8"	10"	12"	14"	16"	18"	20"	22"	24"	26"	28"	30"	32"	34"	36"
8"	X	X	X	X	X	X	X	X	X	X	X	X	X	X	X
10"		X	X	X	X	X	X	X	X	X	X	X	X	X	X
12"			X	X	X	X	X	X	X	X	X	X	X	X	X
14"				X	X	X	X	X	X	X	X	X	X	X	X
16"					X	X	X	X	X	X	X	X	X	X	X
18"						X	X	X	X	X	X	X	X	X	X
20"							X	X	X	X	X	X	X	X	X
22"								X	X	X	X	X	X	X	X
24"									X	X	X	X	X	X	X
26"										X	X	X	X	X	X
28"											X	X	X	X	X
30"												X	X	X	X
32"													X	X	X
34"														X	X
36"															X

Note: When ordering rectangular or oval flow stations, pressure taps will always be located on the longer of the two dimensions.

MODEL CHART - SERIES STRA RECTANGULAR OR OVAL																
Size	40"	44"	48"	52"	56"	60"	66"	72"	78"	84"	90"	96"	102"	108"	114"	120"
8"	X	X	X	X	X	X	X	X	X	X	X	X	X	X	X	X
10"	X	X	X	X	X	X	X	X	X	X	X	X	X	X	X	X
12"	X	X	X	X	X	X	X	X	X	X	X	X	X	X	X	X
14"	X	X	X	X	X	X	X	X	X	X	X	X	X	X	X	X
16"	X	X	X	X	X	X	X	X	X	X	X	X	X	X	X	X
18"	X	X	X	X	X	X	X	X	X	X	X	X	X	X	X	X
20"	X	X	X	X	X	X	X	X	X	X	X	X	X	X	X	X
22"	X	X	X	X	X	X	X	X	X	X	X	X	X	X	X	X
24"	X	X	X	X	X	X	X	X	X	X	X	X	X	X	X	X
26"	X	X	X	X	X	X	X	X	X	X	X	X	X	X	X	X
28"	X	X	X	X	X	X	X	X	X	X	X	X	X	X	X	X
30"	X	X	X	X	X	X	X	X	X	X	X	X	X	X	X	X
32"	X	X	X	X	X	X	X	X	X	X	X	X	X	X	X	X
34"	X	X	X	X	X	X	X	X	X	X	X	X	X	X	X	X
36"	X	X	X	X	X	X	X	X	X	X	X	X	X	X	X	X
40"	X	X	X	X	X	X	X	X	X	X	X	X	X	X	X	X
44"		X	X	X	X	X	X	X	X	X	X	X	X	X	X	X
48"			X	X	X	X	X	X	X	X	X	X	X	X	X	X
52"				X	X	X	X	X	X	X	X	X	X	X	X	X
56"					X	X	X	X	X	X	X	X	X	X	X	X
60"						X	X	X	X	X	X	X	X	X	X	X
66"							X	X	X	X	X	X	X	X	X	X
72"								X	X	X	X	X	X	X	X	X
78"									X	X	X	X	X	X	X	X
84"										X	X	X	X	X	X	X
90"											X	X	X	X	X	X
96"												X	X	X	X	X
102"													X	X	X	X
108"														X	X	X
114"															X	X
120"																X

Note: When ordering rectangular or oval flow stations, pressure taps will always be located on the longer of the two dimensions.

OPTIONS	
To order add suffix:	Description
-IM	Internal pressure connections (rectangular stations only)
-F	Flange (oval stations only)

MODEL CHART - SERIES STRA CIRCULAR														
Size	8"	10"	12"	14"	16"	18"	20"	22"	24"	26"	28"	32"	36"	40"
	X	X	X	X	X	X	X	X	X	X	X	X	X	X
Size	44"	48"	54"	60"	66"	72"	78"	84"	90"	96"	102"	108"	114"	120"
	X	X	X	X	X	X	X	X	X	X	X	X	X	X



SERIES PAFS-1000

# AVERAGING FLOW SENSORS

Ideal for Sensing Fan Flow Rates

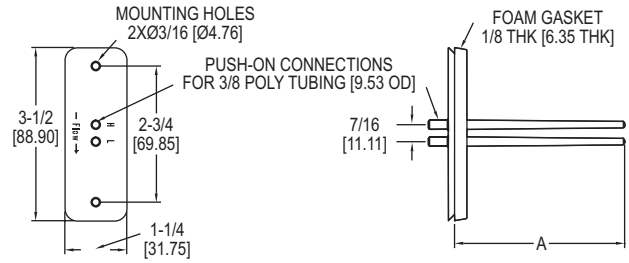

The **Series PAFS-1000 Averaging Flow Sensors** are ideal for sensing velocity pressure in the inlet section of variable air volume terminal units and fan terminal units.

**FEATURES/BENEFITS**

- Simple mounting flange works with both round or rectangular ducts

**APPLICATIONS**

- Zone control in HVAC systems
- Retrofit HVAC air flow measurement

MODEL CHART			
Model	Length (Dim. A) in (cm)	Model	Length (Dim. A) in (cm)
PAFS-1002	3-5/32 (8.02)	PAFS-1007	14-3/4 (37.47)
PAFS-1003	5-13/32 (13.73)	PAFS-1008	17-1/8 (43.50)
PAFS-1004	7-21/32 (19.55)	PAFS-1009	19-13/32 (49.29)
PAFS-1005	9-29/32 (25.26)	PAFS-1010	21-21/32 (55.01)
PAFS-1006	12-1/2 (31.75)	PAFS-1011	23-29/32 (60.72)

**SPECIFICATIONS**

**Service:** Air and compatible gases.  
**Wetted Materials:** ABS/polycarbonate (UL94-5V).  
**Temperature Limits:** Operating: 40 to 120°F (4 to 49°C); Storage: -40 to 140°F (-40 to 60°C).  
**Process Connection:** 1/4" (6 mm) ID, 3/8" (10 mm) OD tubing.  
**Mounting Orientation:** Integral flange with gasket.  
**Weight:** 1 oz (28 g).  
**Agency Approvals:** Meets the technical requirements of EU Directive 2011/65/EU (RoHS II).

SERIES AFG

# AVERAGING FLOW GRID

Cost Effective Air Flow Station for Ducts up to 60"

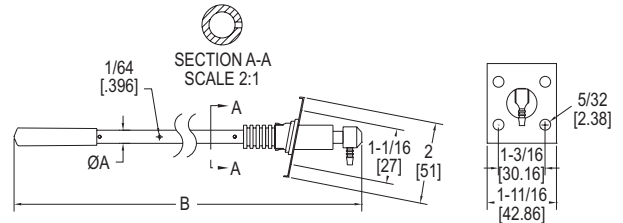
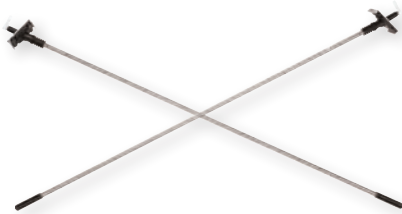

The **Series AFG Averaging Flow Grid** is a fundamental pressure-sensing device designed to sense velocity pressure in an air duct. When this output is connected to a suitable measuring instrument (i.e. manometer, pressure transducer, etc.) it may be used to determine air velocity or air flow rate.

**FEATURES/BENEFITS**

- Kit complete with 2 probes and installation hardware
- Trimmable length for any duct size up to 60"
- Alternative to costly air flow stations

**APPLICATIONS**

- To display differential pressure, velocity or volume flow using a micro manometer, gage or transmitter
- To give a warning of over or under flow rate using a pressure switch
- To control air supply in a system by connecting the grid to a pressure transmitter with an electrical output which can be used to feed into a control system
- To display differential pressure on a simple fluid manometer to give visual indication of changes in volume flow rate in the duct

**SPECIFICATIONS**

**Service:** Monitor air or compatible gas flow.  
**Wetted Materials:** 304 SS, PVC, polyurethane, acetyl plastics, and neoprene rubber.  
**Accuracy:** ±5%.  
**Maximum Temperature:** 176°F (80°C).  
**Velocity Range:** 295.2 ft/min to 5904 ft/min (1.5 to 30 m/s).  
**Diameter of Tubes:** 5/16" (8 mm) or 5/8" (16 mm).  
**Maximum Duct Diagonal:** 60.4" (153.4 cm).  
**Maximum Duct Diameter:** 59.4" (150.9 cm).  
**Process Connections:** 5/16" barbed.  
**Weight:** AFG-1: 1 lb (454 g); AFG-2: 3 lb (1361 g).

MODEL CHART		
Model	Diameter Tube (Dim. A) in (mm)	Length (Dim. B) in (mm)
AFG-1	5/16 (8)	27 (688)
AFG-2	5/8 (16)	59-4/5 (1518)

# METAL AVERAGING FLOW SENSOR

Blade Profile Provides Enhanced Performance and Minimal Flow Disruption

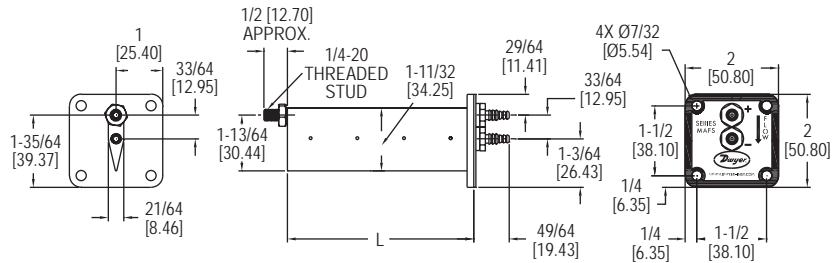

The **Series MAFS Metal Averaging Flow Sensor** is ideal for use with Dwyer Instruments, Inc. precision air velocity gages, transmitters and switches. The Series MAFS uses evenly distributed total and static pressure measuring points to deliver an accurate measurement of velocity pressure in a duct.

**FEATURES/BENEFITS**

- Blade design limits disruption of air stream
- Lightweight aluminum construction
- Flange mount for rectangular or square ducts

**APPLICATIONS**

- VAV air flow measurement
- Fume hood exhaust flow verification
- HVAC retrofit air flow measurement

**SPECIFICATIONS**

**Service:** Clean air.  
**Wetted Materials:** Aluminum AA6063.  
**Accuracy:** 400 to 9000 FPM (45.7 m/s); ±2% FS, ±3% FS for 6" (160 mm) and 48" (1200 mm) length models.  
**K-Factor:** 0.81, 0.80 for 6" (160 mm) and 48" (1200 mm) lengths, 4" (100 mm) length=0.82.  
**Maximum Temperature:** 400°F (204°C); Gasket: -31 to 230°F (-35 to 110°C).  
**Minimum Design Flow:** 400 fpm (2 m/s).  
**Maximum Design Flow:** 12,000 fpm (60.91 m/s).  
**Process Connections:** Dual barb for 3/16" or 1/4" ID tubing.  
**Straight Run Requirements:** 5 diameters or longest side dimensions.  
**Agency Approvals:** Meets the technical requirements of EU Directive 2011/65/EU (RoHS II).

MODEL CHART							
Model	Probe Length (in)	Model	Probe Length (in)	Model	Probe Length (mm)	Model	Probe Length (mm)
MAFS-4	4	MAFS-24	24	MAFS-100MM	100	MAFS-550MM	550
MAFS-6	6	MAFS-26	26	MAFS-125MM	125	MAFS-600MM	600
MAFS-8	8	MAFS-28	28	MAFS-160MM	160	MAFS-630MM	630
MAFS-10	10	MAFS-30	30	MAFS-200MM	200	MAFS-650MM	650
MAFS-12	12	MAFS-32	32	MAFS-250MM	250	MAFS-750MM	750
MAFS-14	14	MAFS-34	34	MAFS-300MM	300	MAFS-800MM	800
MAFS-16	16	MAFS-36	36	MAFS-315MM	315	MAFS-1000MM	1000
MAFS-18	18	MAFS-40	40	MAFS-400MM	400	MAFS-1500MM	1500
MAFS-20	20	MAFS-48	48	MAFS-450MM	450	MAFS-2000MM	2000
MAFS-22	22			MAFS-500MM	500		

**Dwyer**  
MODEL 670

# FUME HOOD MONITOR

Ensures Proper Fume Hood Performance

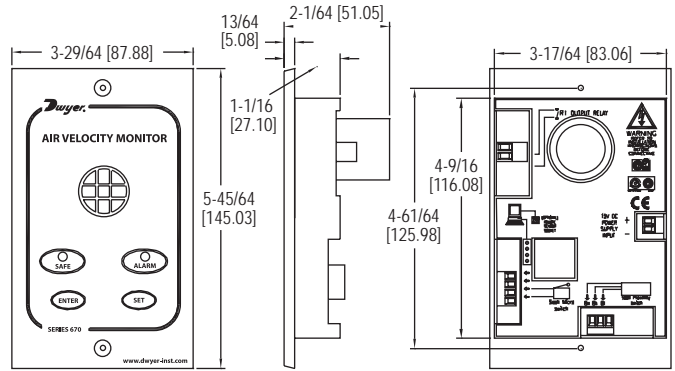

The **Model 670 Fume Hood Monitor** continuously senses air flow through the face of the fume hood, ensuring safe levels of fresh air are exhausting. The 670 provides a highly accurate hot wire sensor to detect very low flows common on fume hoods. The Model 670 comes with everything required to quickly install the unit including a mounting bracket, 24" of tubing for connecting to the inside of the hood wall and a 120 Volt AC power adapter.

**FEATURES/BENEFITS**

- Flexible surface or flush mounting
- LED safe and alarm status indicators
- Audible alarm
- Sash alarm input
- Night time set-back

**APPLICATIONS**

- Fume hood ventilation monitoring

MODEL CHART	
Model	Description
670	Fume hood monitor

**SPECIFICATIONS**

**Service:** Fume hood face velocity air flow.  
**Alarm Range:** 30-400 FPM (0.15-2.0 m/s).  
**Alarm Indication:** Red LED & audible alarm.  
**Low Air Velocity Alarm Delay:** Fixed 5 secs.  
**Visual LED Display:** Red: Alarm; Green: Normal.  
**Horn Silence:** Yes-temporary and permanent.  
**Accuracy:** Face velocity ±10%.  
**Temperature Limits:** Operating temperature: 55 to 86°F (13 to 30°C); Storage temperature: -40 to 150°F (-40 to 65°C).  
**Power Requirement:** 15 VDC 500 mA; 120 VAC, 60 Hz power transformer included.  
**Relay Output Low Air Flow Alarm:** 5 A @ 250 VAC.  
**Relay Input For Night Setback:** 2 wire rated for 24 VDC usage.  
**Sash High Indication:** Using a two wire micro switch or 3 wire proximity switch input, rated for 24 VDC usage.  
**Mounting:** Semi flush, flush or surface mounted when using included bracket.  
**Weight:** 5.0 oz (141 g).

MODEL AAFS

# ADJUSTABLE AIR FLOW PADDLE SWITCH

Ranges from 200 to 1800 FPM, Stainless Steel Vane, ABS Housing

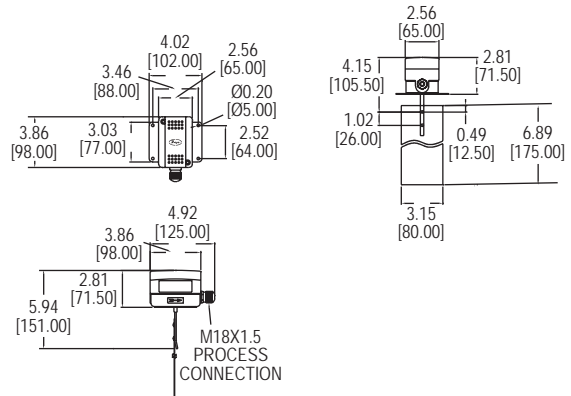

The **Model AAFS Adjustable Air Flow Paddle Switch** is capable of detecting a wide range of air velocities with minimal user calibration. Quality features include a stainless steel vane, galvanized steel base, and ABS enclosure.

**FEATURES/BENEFITS**

- Adjustable air flow sensitivity from 200 to 1800 FPM
- High current (15 A) rated SPDT contact
- IP65 enclosure rating

**APPLICATIONS**

- Air flow proving in HVAC systems

MODEL CHART	
Model	Description
AAFS	Adjustable air flow paddle switch

**SPECIFICATIONS**

**Service:** Air and compatible gas.  
**Wetted Materials:** Vane: SS; Lever: Brass; Base: Galvanized steel.  
**Housing:** ABS.  
**Temperature Limits:** Ambient: -40 to 180°F (-40 to 85°C); Process: -14 to 185°F (-10 to 85°C).  
**Humidity Limits:** 10 to 90%, non-condensing.  
**Switch Type:** SPDT.  
**Electrical Rating:** 15 (8) A @ 250 VAC.  
**Electrical Connection:** Screw terminal with M18 x 1.5 cable gland.  
**Process Connection:** Flange.  
**Mounting Orientation:** Horizontal duct flow.  
**Set Point:** Internal screw.  
**Enclosure Rating:** IP65.  
**Weight:** 13.6 oz (380 g).  
**Agency Approvals:** CE.

USA: California Proposition 65  
 ⚠WARNING: Cancer and Reproductive Harm - www.P65Warnings.ca.gov



# AIR FLOW SWITCH

Monitors Flow in Ducts with Contact Output and Local LED Indication

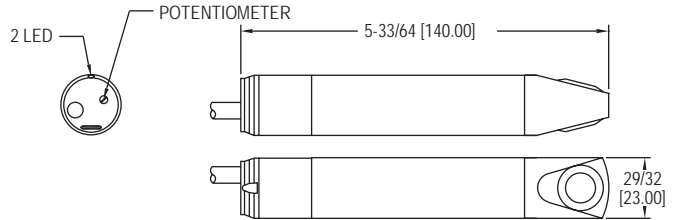

The **Series AVFS Air Flow Switch** is specifically designed to monitor air flow in ducts and provides a 3 A contact output to indicate a change or loss of flow. The AVFS provides a +/-5% set point repeatability across a full-scale range of 1-10 m/s (197-1969 fpm) and includes a mounting bracket for quick duct mounting.

**FEATURES/BENEFITS**

- Integral red/green air flow status LED's
- Flush sensor design limits issues due to dust or particulate in the air flow
- IP65 construction

**APPLICATIONS**

- Fan monitoring
- Filter monitoring
- Damper feedback
- Air handlers

MODEL CHART	
Model	Description
AVFS-1	80-250 AC/DC power thermo air flow switch
AVFS-2	24 VDC power thermo air flow switch

SPECIFICATIONS
<b>Air Velocity Range:</b> 197-1969 FPM (1-10 m/s).
<b>Temperature Limits:</b> 5 to 122°F (-10 to 50°C).
<b>Humidity Limits:</b> 0-90% RH.
<b>Wetted Materials:</b> PBT body, titanium sensor.
<b>Pressure Limit:</b> 14.7 psig (1 bar).
<b>Housing:</b> PBT.
<b>Repeatability:</b> ±5% FS.
<b>Switch Type:</b> N.O. SPST.
<b>Electrical Rating:</b> 3 A @ 30 VDC/250 VAC.
<b>Response Time:</b> 3-60 seconds. Varies with flow and set point.
<b>Power Requirement:</b> AVFS-1: 80 to 250 AC/DC (47 to 63 Hz AC); AVFS-2: 24 VDC ±25%.
<b>Power Consumption:</b> 3 VA.
<b>Electrical Connection:</b> 6.5' (2 m) cable.
<b>Enclosure Rating:</b> IP65.
<b>Display:</b> 1 Red LED/1 Green LED.
<b>Weight:</b> 7.2 oz (203 g).
<b>Agency Approvals:</b> CE.

SERIES DAFA

# AIR FLOW INDICATOR AND ALARM

For Air Flow Monitoring in 3" and 4" pipes

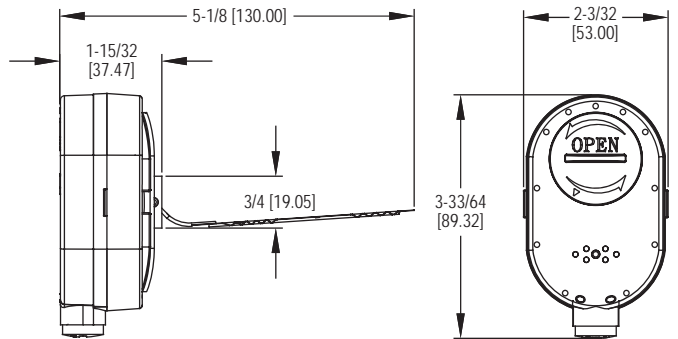

The **Series DAFA Air Flow Indicator and Alarm** alerts users of low or no air flow conditions in pipes utilizing a thin, field trimmable vane to sense the air flow rate. An 85 dB audible buzzer alternates with a bright red LED to alert users when the air flow rate drops, indicating low or no flow in the pipe. The DAFA is battery powered to provide versatility for where it can be installed, and offers a yellow LED to indicate a low battery. This device is ideal for monitoring radon mitigation systems by detecting a loss of air flow in the pipe and providing a signal to homeowners if the fan has stopped operating.

**FEATURES/BENEFITS**

- Simple and quick installation
- Field trimmable vane included to allow unit to be used in 3" and 4" pipes
- Audible and visual alarms
- Battery-operated with up to 5 year battery life and low battery warning

**APPLICATIONS**

- Radon mitigation systems
- Air flow monitoring in 3" and 4" pipes

MODEL CHART	
Model	Description
DAFA-1	Air flow indicator and alarm

SPECIFICATIONS
<b>Service:</b> Clean air.
<b>Actuation Point:</b> 15 CFM (4" pipe); 10 CFM (3" pipe) on decrease in flow.
<b>Audible Alarm:</b> At least 85 dB @ 1 foot distance.
<b>Visual Alarm:</b> Red LED for no flow alarm; Yellow LED for low battery.
<b>Wetted Materials:</b> ABS, polycarbonate, rare earth magnet.
<b>Power Requirements:</b> 3 V CR2450 lithium battery, included, user replaceable.
<b>Battery Life:</b> 5 years steady state; 48 hours during alarm state.
<b>Temperature Limits:</b> 32 to 122°F (0 to 50°C).
<b>Mounting Orientation:</b> Vertical.
<b>Weight:</b> 4 oz (113.4 g).
<b>Agency Approvals:</b> CE.

ACCESSORIES	
Model	Description
A-DAFA-VANE	Replacement trimmable vane
A-DAFA-BCOV	Replacement battery cover

# AIR VELOCITY TRANSMITTERS

3% and 5% Models, Optional BACnet or Modbus® Communication Protocols

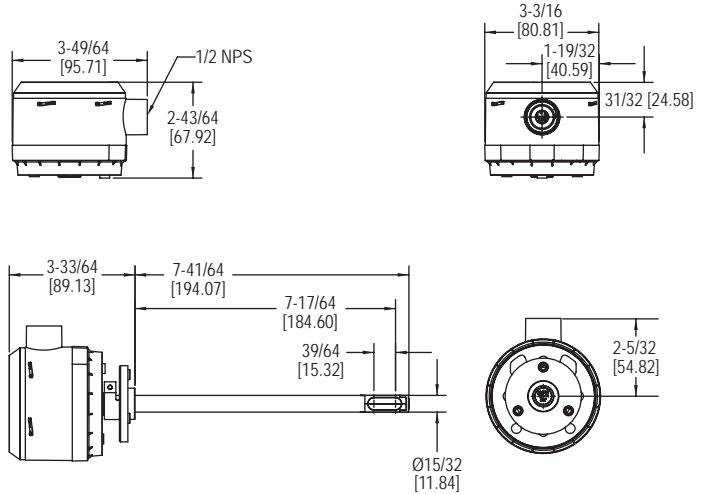

The **Series AVUL Air Velocity Transmitters** quickly and accurately measures air velocity or volumetric flow in imperial or metric units. Simultaneous current and voltage outputs on all models provide universal inputs to monitoring equipment while the output range, units, and 0 to 5/10 VDC output can be configured via local DIP switches. The optional integral display, or the portable remote display tool, provide a convenient way to locally monitor process values and configure the unit. Models are available in 3% and 5% accuracy models to suit a variety of needs, and the optional BACnet MS/TP or Modbus® RTU/ASCII communication protocol allows units to be daisy-chained while providing access to all of the velocity and flow data, as well as additional information such as air temperature.

**FEATURES/BENEFITS**

- Sensing elements have been coated with an engineered conformal coating to ensure durability and longevity
- Field selectable ranges can be quickly configured without power to the unit

**APPLICATIONS**

- VAV systems
- Building ducts

MODEL CHART	
Model	Description
AVUL-5DA1	Air velocity transmitter, 5% accuracy, duct mount, Universal current/voltage outputs
AVUL-5DA1-LCD	Air velocity transmitter, 5% accuracy, duct mount, Universal current/voltage outputs, with LCD
AVUL-5DB1	Air velocity transmitter, 5% accuracy, duct mount, BACnet communications
AVUL-5DB1-LCD	Air velocity transmitter, 5% accuracy, duct mount, BACnet communications, with LCD
AVUL-5DM1	Air velocity transmitter, 5% accuracy, duct mount, Modbus® communications
AVUL-5DM1-LCD	Air velocity transmitter, 5% accuracy, duct mount, Modbus® communications, with LCD
AVUL-3DA1	Air velocity transmitter, 3% accuracy, duct mount, Universal current/voltage outputs
AVUL-3DA1-LCD	Air velocity transmitter, 3% accuracy, duct mount, Universal current/voltage outputs, with LCD
AVUL-3DB1	Air velocity transmitter, 3% accuracy, duct mount, BACnet communications
AVUL-3DB1-LCD	Air velocity transmitter, 3% accuracy, duct mount, BACnet communications, with LCD
AVUL-3DM1	Air velocity transmitter, 3% accuracy, duct mount, Modbus® communications
AVUL-3DM1-LCD	Air velocity transmitter, 3% accuracy, duct mount, Modbus® communications, with LCD

**SPECIFICATIONS**

**Service:** Clean air and non-combustible, compatible gases.  
**Wetted Materials:** Consult factory.  
**Range:** 1000, 2000, 3000, 4000 FPM (5, 10, 15, 20 m/s); Field selectable.  
**Accuracy:** ±(5% of reading + 0.2 m/s) or ±(3% of reading + 0.2 m/s) @ standard conditions, depending on model.  
**Temperature Limits:** 32 to 122°F (0 to 50°C).  
**Power Requirements:** 24 VDC ±20% or 24 VAC ±20%.  
**Humidity Limits:** 5 to 95% RH, non-condensing.  
**Output Signals:** 4 to 20 mA, 0 to 5 VDC, 0 to 10 VDC.  
**Response Time (90%):** 10 s, typical.  
**Zero & Span Adjustments:** Digital push-buttons.  
**Output Load Resistance:** Current output: 0 to 1100 Ω max.; Voltage output: Minimum load resistance 1 kΩ.  
**Current Consumption:** 60 mA max.  
**Display (optional):** 5 digit LCD.  
**Electrical Connections (Analog):** Power and output: four wire removable European style terminal block for 16 to 26 AWG.  
**Communication (optional):** Connections: BACnet MS/TP or Modbus® RTU/ASCII: three wire removable European style terminal block for 16 to 26 AWG; Supported baud rates: 9600, 19200, 38400, 57600, 76800, 115200.  
**Device Load:** 1/8th unit load.  
**Electrical Entry:** 1/2" NPS thread. Accessory (A-151): Cable gland for 5 to 10 mm diameter cable.  
**Enclosure Rating:** NEMA 4X (IP66).  
**Mounting Orientation:** Flow direction must be parallel to the sensor tip.  
**Weight:** 6.0 oz (160 g).  
**Agency Approval:** BTL, CE.

**ACCESSORIES**

Model	Description
A-151	Cable gland for 5 to 10 mm diameter cable
A-435-A	Remote display tool
A-AVUL-LCD	Field upgradeable display
A-AVUL-MTG	Replacement mounting flange
SCD-PS	100 to 240 VAC/VDC to 24 VDC power supply

Modbus® is a registered trademark of Schneider Automation, Inc.

# AIR VELOCITY TRANSMITTERS

## High Accuracy, Field Selectable Ranges

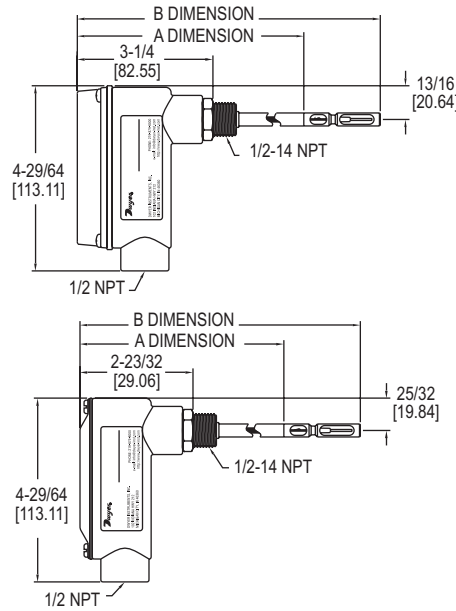

641 AVT WITH DISPLAY OPTION	
A Dimension	B Dimension
7-63/64 [202.80]	9-13/16 [249.24]
13-63/64 [355.20]	15-13/16 [401.64]
19-63/64 [507.60]	21-13/16 [554.04]
26-63/64 [685.40]	28-13/16 [731.84]
32-63/64 [837.80]	34-13/16 [884.24]
37-63/64 [964.80]	39-13/16 [1011.24]

641 AVT WITHOUT DISPLAY OPTION	
A Dimension	B Dimension
7-7/16 [188.91]	9-9/32 [235.74]
13-7/16 [341.31]	15-9/32 [388.14]
19-7/16 [493.71]	21-9/32 [540.54]
26-7/16 [671.51]	28-9/32 [718.34]
29-7/16 [747.71]	34-9/32 [870.74]
37-7/16 [950.91]	39-9/32 [997.74]

The **Series 641 Air Velocity Transmitters** are the ideal instrument for monitoring air flow. This transmitter uses a heated mass flow sensor which allows for precise velocity measurements at various flow rates and temperatures. The 641's 16 field-selectable ranges provides it the versatility to be selected for several air flow applications. The optional LED produces a complete, low-cost solution for local indication of air flow.

### FEATURES/BENEFITS

- Ranges from 250 FPM (1.25 MPS) to 15,000 FPM (75 MPS)
- Optional bright LED display
- Easy push-button set-up
- Compact housing
- 4-20 mA output
- Digital filter for signal damping

### APPLICATIONS

- Exhaust stack flow monitoring
- Air control in drying processes
- HVAC air velocity measurements
- Fan supply and exhaust tracking
- Clean room ventilation monitoring

MODEL CHART	
Model	Probe Length*
641-6	6" (152.4 mm)
641-6-LED	6" (152.4 mm)
641-12	12" (304.8 mm)
641-12-LED	12" (304.8 mm)
641-18	18" (457.2 mm)
641-18-LED	18" (457.2 mm)
641-24	24" (609.6 mm)
641-24-LED	24" (609.6 mm)

\*Other probe lengths available contact factory.

OPTIONS	
To order add suffix:	Description
-NIST	NIST traceable calibration certificate

Example: 641-6-NIST

ACCESSORIES	
Model	Description
A-156	Universal mounting plate, 1/2" female NPT
A-158	Split flange mounting kit
A-159	Duct mounting gland
641-LED	Field-upgradeable LED

### SPECIFICATIONS

**Service:** Clean air and compatible, non-combustible gases.  
**Accuracy:** 3% FS process gas: 32 to 122°F (0 to 50°C); 4% FS process gas: -40 to 32°F & 122 to 212°F (-40 to 0°C & 50 to 100°C).  
**Response Time:** Flow: 1.5 s to 95% of final value (output filter set to minimum).  
**Temperature Limits:** Process: -40 to 212°F (-40 to 100°C); Ambient: 32 to 140°F (0 to 60°C).  
**Pressure Limit:** 100 psi (6.89 bar) maximum.  
**Humidity Limit:** Non-condensing.  
**Power Requirements:** 12-35 VDC, 10-16 VAC. 1.5 A rating required on supply due to initial power surge drawn by transmitter.  
**Output Signal:** 4-20 mA, isolated 24 V source, 3 or 4-wire connection.  
**Output Filter:** Selectable 0.5-15 (s).  
**Loop Resistance:** 600 Ω max.  
**Current Consumption:** 300 mA max.  
**Electrical Connections:** Screw terminal.  
**Process Connections:** 1/2" male NPT.  
**Enclosure Rating:** Designed to meet NEMA 4X (IP66) for non LED models only.  
**Mounting Orientation:** Unit not position sensitive. Probe must be aligned with airflow.  
**Weight:** 12.6 oz (357.2 g).  
**Agency Approval:** CE.

**OPTIONAL DISPLAY VERSION:**  
**Display:** 4-1/2 digit 1/2" red LED.  
**Resolution:** 1 FPM, 0.01 MPS (10 FPM @ 10,000 and 15,000 FPM ranges).  
**Weight:** 13.3 oz (377 g).

**Dwyer**  
SERIES 641RM

# AIR VELOCITY TRANSMITTER WITH REMOTE PROBE

For Remotely Mounting Electronic Enclosure

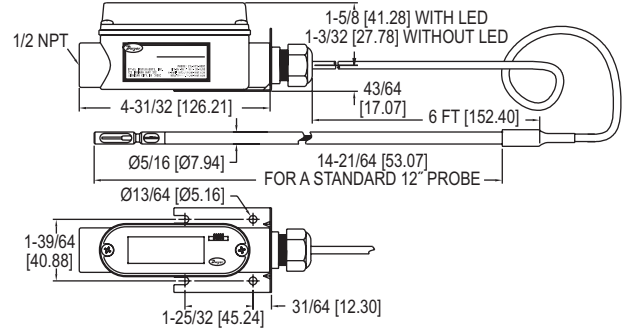

The **Series 641RM Air Velocity Transmitter with Remote Probe** features the same highly accurate heated mass flow sensor as the Series 641, with a remote probe construction. The units 6' cable which connects the sensing probe with the electronic enclosure allows the enclosure to be mounted where it can be more easily accessed.

**FEATURES/BENEFITS**

- Ranges from 250 FPM (1.25 MPS) to 15,000 FPM (75 MPS)
- Optional bright LED display
- Easy push-button set-up
- Compact housing
- 4 to 20 mA output
- Digital filter for signal damping

**APPLICATIONS**

- Exhaust stack flow monitoring
- Air control in drying processes
- HVAC air velocity measurements
- Fan supply and exhaust tracking
- Clean room ventilation monitoring

MODEL CHART	
Model	Description
641RM-12	Air velocity transmitter with 6' cable
641RM-12-LED	Air velocity transmitter with 6' cable with LED display

OPTIONS	
To order add suffix:	Description
-NIST	NIST traceable calibration certificate
<b>Example:</b> 641RM-12-NIST	

**SPECIFICATIONS**

**Service:** Clean air and compatible, non-combustible gases.  
**Accuracy:** 3% FS process gas: 32 to 122°F (0 to 50°C); 4% FS process gas: -40 to 32°F & 122 to 212°F (-40 to 0°C & 50 to 100°C).  
**Response Time:** Flow: 1.5 s to 95% of final value (output filter set to minimum).  
**Temperature Limits:** Process: -40 to 212°F (-40 to 100°C); Ambient: 32 to 140°F (0 to 60°C).  
**Pressure Limit:** 100 psi (6.89 bar) maximum.  
**Humidity Limit:** Non-condensing.  
**Power Requirements:** 12 to 35 VDC, 10 to 16 VAC. 1.5 A rating required on supply due to initial power surge drawn by transmitter.  
**Output Signal:** 4 to 20 mA, isolated 24 V source, 3 or 4-wire connection.

**Output Filter:** Selectable 0.5–15 (seconds).  
**Loop Resistance:** 600 Ω max.  
**Current Consumption:** 300 mA max.  
**Electrical Connections:** Screw terminal.  
**Mounting Orientation:** Unit not position sensitive. Probe must be aligned with airflow.  
**Weight:** 13.2 oz (374.26 g).  
**Cable Length:** 6' (1.82 m).  
**Probe Length:** 12" (30.48 cm) standard.  
**Probe Diameter:** 5/16" (0.79 cm).  
**OPTIONAL DISPLAY VERSION:**  
**Display:** 4-1/2 digit 1/2" red LED.  
**Resolution:** 1 FPM, 0.01 MPS (10 FPM @ 10,000 and 15,000 FPM ranges).  
**Weight:** 13.9 oz (394.16 g).

**ACCESSORIES**

Model	Description
A-156	Universal mounting plate, 1/2" female NPT
A-158	Split flange mounting kit
A-159	Duct mounting gland
641-LED	Field-upgradeable LED

SERIES 641B

# AIR VELOCITY TRANSMITTER

Dirty Air Flow Applications

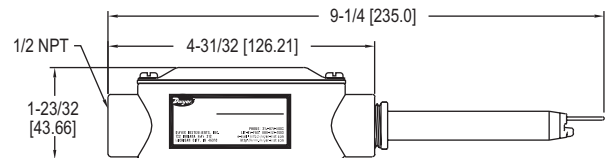

The **Series 641B Air Velocity Transmitter** uses a heated mass flow sensor suitable for dirty air flow applications. It has user-selectable ranges from 250 FPM (1.25 MPS) to 2000 FPM (10 MPS).

**FEATURES/BENEFITS**

- SS sensor suitable for dirty air flow measurement
- Ranges from 250 FPM (1.25 MPS) to 2000 FPM (10 MPS)
- 4 to 20 mA output
- Digital filter for signal damping

**APPLICATIONS**

- Exhaust stack flow monitoring
- Air control in drying processes
- HVAC air velocity measurements
- Fan supply and exhaust tracking
- Clean room ventilation monitoring

MODEL CHART	
Model	Description
641B-4	Air velocity transmitter
641B-4-LED	Air velocity transmitter with LED display

**SPECIFICATIONS**

**Service:** Air and compatible, non-combustible gases.  
**Accuracy:** 5% FS process gas: 32 to 122°F (0 to 50°C). 6% FS process gas: -40 to 32°F & 122 to 176°F (-40 to 0°C & 50 to 80°C).  
**Response Time:** Flow: 1.5 s to 95% of final value (output filter set to minimum).  
**Temperature Limits:** Process: -40 to 176°F (-40 to 80°C); Ambient: 32 to 140°F (0 to 60°C).  
**Humidity Limit:** Non-condensing.  
**Power Requirements:** 12 to 35 VDC, 10 to 16 VAC. 1.5 A rating required on supply due to initial power surge drawn by transmitter.

**Output Signal:** 4 to 20 mA, isolated 24 V source, 3- or 4-wire connection.  
**Output Filter:** Selectable 0.5–15 (seconds).  
**Loop Resistance:** 600 Ω max.  
**Current Consumption:** 300 mA max\*.  
**Electrical Connections:** Screw terminal.  
**Enclosure Rating:** Designed to meet NEMA 4X (IP66) for non LED models only.  
**Mounting Orientation:** Unit not position sensitive.  
**Weight:** 12.6 oz (357.2 g).

\*A brief current transient exceeding 300 mA may be seen on startup

**ACCESSORIES**

Model	Description
A-155	Mounting gland with 1/2" male NPT fitting
A-156	Flange mounting plate with 1/2" female NPT



# HUMIDITY SWITCH

Programmable, 8 A Relay, 3-Digit Display

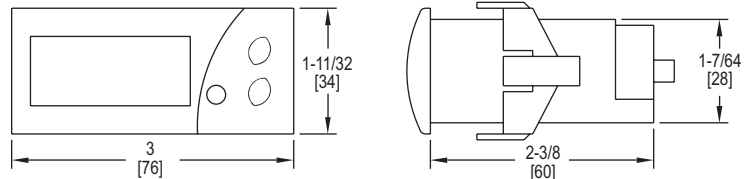

Panel cutout 2-51/64" x 1-9/64" (71 x 29 mm)

The **Series HS Humidity Switch** provides control for humidifying or dehumidifying systems. Relative humidity, output status, and error messaging can be viewed on the bright green LED. Access to programming parameters can be locked for security purposes using the password protection feature.

**FEATURES/BENEFITS**

- Relative humidity display and control
- Parameter protection
- 0 to 1 V, 4 to 20 mA or 3 V (THC-P) input selection

**APPLICATIONS**

- Environmental chambers
- Beer and wine chillers
- Greenhouses

MODEL CHART	
Model	Supply Power
HS-311	115 VAC
HS-312	230 VAC

**SPECIFICATIONS**

<b>Relative Humidity Range:</b> 10 to 100% RH.	<b>Output:</b> 16 A SPDT relay @ 250 VAC resistive.
<b>Input:</b> 0 to 1 V, 3 V or 4 to 20 mA.	<b>Horsepower Rating (HP):</b> 1 HP.
<b>Accuracy:</b> THC-P: ±5% @ 20 to 90%; HS: ±1% RH.	<b>Control Type:</b> ON/OFF.
<b>Display:</b> 3-digit, green, 1/2" (12.7 mm) digits.	<b>Power Requirements:</b> 115 VAC or 230 VAC (depending on model).
<b>Resolution:</b> 1 digit.	<b>Memory Backup:</b> Nonvolatile memory.
<b>Temperature Limits:</b> 32 to 158°F (0 to 70°C).	<b>Weight:</b> 2.3 oz (65 g).
<b>Storage Temperature:</b> -4 to 176°F (-20 to 80°C).	<b>Front Panel Rating:</b> IP64.
	<b>Agency Approvals:</b> CE, cURus.

**ACCESSORIES**

Model	Description
THC-P	Humidity probe, 3 V output, 4' (1.2 m) cable

SERIES THC

# TEMPERATURE/HUMIDITY SWITCH

Independent Displays, 61 Programmable Parameters, 4 SPST Relays

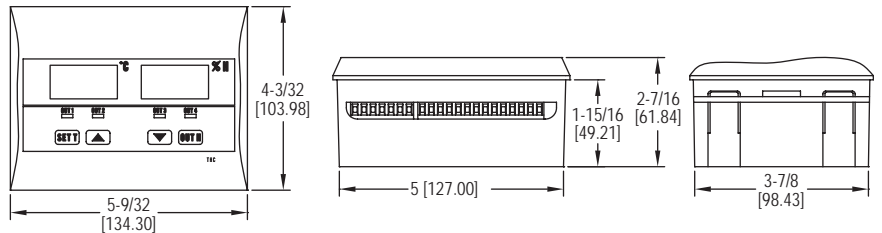

The **Series THC Temperature/Humidity Switch** simultaneously measures and controls temperature and humidity. The unit offers a 3-digit red display for temperature indication and a 3-digit green display indicating humidity. The Series THC is equipped with four independent relays, two for temperature control and two relays for humidity control.

The THC Temperature/Humidity Switch accepts up to two temperature probe inputs (sold separately) and a humidity sensor. A humidity sensor with 0 to 1 V, 3 V (THC-P sold separately), or 4 to 20 mA output can be used with the Series THC.

**FEATURES/BENEFITS**

- Temperature and humidity control in one device
- Password protected parameter settings
- Selectable fail safe status of relay outputs

**APPLICATIONS**

- Isolation chambers
- Environmental chambers
- Greenhouses
- Beer and wine chillers

MODEL CHART		
Model	Supply Power	Unit
THC-10	115 VAC	°F
THC-11	115 VAC	°C
THC-20	230 VAC	°F
THC-21	230 VAC	°C

**SPECIFICATIONS**

<b>Measurement Range:</b> Temperature: -58 to 302°F (-50 to 150°C); Humidity: 0 to 100% RH.	<b>Display:</b> Two 3-digit displays. 1/2" digits.
<b>Input:</b> Up to 2 thermistors and 1 humidity sensor.	<b>Resolution:</b> 0.1°.
<b>Output:</b> 4 SPST, 8 A relays @ 250 VAC.	<b>Memory Backup:</b> Nonvolatile memory.
<b>Horsepower Rating (HP):</b> 1/3 HP.	<b>Ambient Operating Temperature:</b> 32 to 158°F (0 to 70°C).
<b>Control Type:</b> ON/OFF direction, direct or reverse acting, neutral.	<b>Storage Temperature:</b> -4 to 176°F (-20 to 80°C).
<b>Power Requirements:</b> 110 or 230 VAC (depending on model).	<b>Weight:</b> 1.17 lb (530 g).
<b>Accuracy:</b> Temperature ±0.5% of probe range; Humidity: 20 to 90%.	<b>Panel Cutout:</b> 5.15" x 3.97" (131 x 101 mm).
	<b>Front Panel Protection:</b> IP64.
	<b>Agency Approvals:</b> CE.

**ACCESSORIES**

Model	Description
THC-P	Humidity probe, 3 V output, 4 ft (1.2 m) cable
TS-5	Temperature probe, PVC with 5 ft (1.5 m) cable
TS-6	Temperature probe, metal with 5 ft (1.5 m) cable
TS-51	Temperature probe, PVC with 10 ft (3 m) cable
TS-61	Temperature probe, metal with 10 ft (3 m) cable

# WALL MOUNT HUMIDITY/TEMPERATURE/DEW POINT TRANSMITTERS

Optional LCD Display

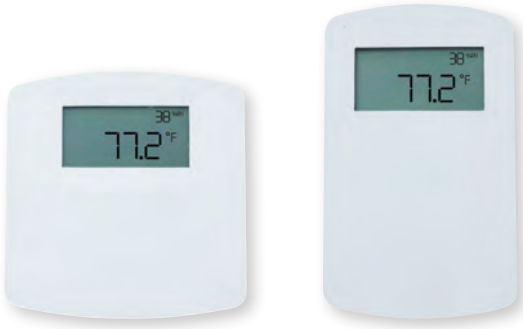

European style

North American style

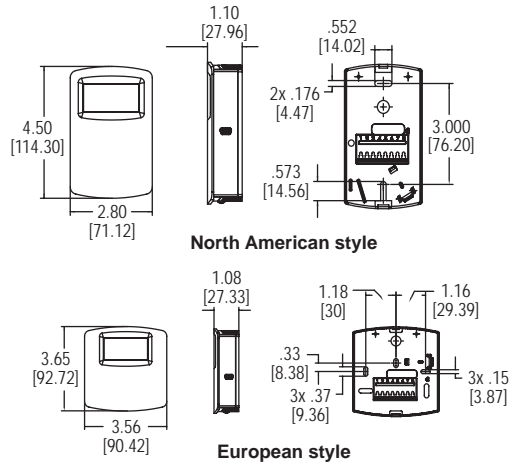

The Series RHP-E/N Wall Mount Humidity/Temperature/Dew Point Transmitters are the most versatile room transmitter on the market. The stylish housing is well vented to provide air flow across the sensor to improve measurement accuracy. The humidity and the dew point are measured using a capacitive polymer sensor. The humidity and dew point can have either a current or voltage output, while the optional temperature output can be a current, voltage, RTD or thermistor. For models with current or voltage for the temperature output, the temperature range is field selectable.

**FEATURES/BENEFITS**

- Field selectable relative humidity or dew point output
- Universal analog outputs
- Integral or service tool LCD display options
- Two housing designs to match North American and European aesthetics

**APPLICATIONS**

- Air economizers
- Room comfort monitoring
- Greenhouse monitoring

**SPECIFICATIONS**

**Relative Humidity Range:** 0 to 100% RH.

**Temperature Range:** -40 to 140°F (-40 to 60°C) for thermistor and RTD sensors. -20 to 140°F (-28.9 to 60°C) for solid state band gap temperature sensors.

**Dew Point Temperature Range:** -20 to 140°F (-28.9 to 60°C); 0 to 100°F (-17.8 to 37.8°C); 40 to 90°F (4.4 to 32.3°C); -4 to 140°F (-20 to 60°C) field-selectable ranges.

**Accuracy:** RH: Model RHP-2XXX ±2% 10 to 90% RH @ 25°C; Model RHP-3XXX ±3% 20 to 80% RH @ 25°C; Model RHP-5XXX ±5% 20 to 80% RH @ 25°C; Thermistor temperature sensor: ±0.36°F @ 77°F (±0.2°C @ 25°C); RTD temperature sensor: DIN Class B; ±0.54°F @ 32°F (±0.3°C @ 0°C); Solid state band gap temperature sensor: ±0.9°F @ 77°F (±0.3°C @ 25°C).

**Hysteresis:** ±0.8%.

**Repeatability:** ±0.1% typical.

**Temperature Limits:** Operating: -40 to 140°F (-40 to 60°C); Storage: -40 to 176°F (-40 to 80°C).

**Compensated Temperature Range:** -4 to 140°F (-20 to 60°C).

**4-20 mA Loop Powered Outputs:** Power requirements: 10-35 VDC; Output signal: 4-20 mA, 2 channels for humidity/solid state temperature sensor models (loop powered on RH). Switch selectable RH/dew point. Switch selectable normal or reverse output.

**0-5/10V Outputs:** Power requirements: 15-35 VDC or 15-29 VAC; Output load: 5 mA max., 2 channels for humidity/solid state temperature sensor models. Switch selectable 0-10 V/2-10 V or 0-5 V/1-5 V output. Switch selectable RH/dew point. Switch selectable normal or reverse output.

**Solid State Band Gap Temperature Sensor Output Ranges:** Switch selectable, -20 to 140°F (-28.9 to 60°C); 0 to 100°F (-17.8 to 37.8°C); 40 to 90°F (4.4 to 32.3°C); -4 to 140°F (-20 to 60°C).

**Response Time:** 8 s.

**Electrical Connections:** Screw terminal block.

**Drift:** <0.25% RH/year.

**RH Sensor:** Capacitance polymer.

**Enclosure Material:** Polycarbonate.

**Enclosure Rating:** IP20.

**Display:** Optional LCD; Switch selectable %RH or dew point, °F/°C.

**Display Resolution:** RH: 1%; Temperature: 0.1°F (0.1°C); Dew point: 1°F (1°C).

**Weight:** 4.4 oz (125 g).

**Agency Approvals:** CE.

MODEL CHART						
Example	RHP	-3	N	4	A	-LCD RHP-3N4A-LCD
Series	RHP					Humidity/temperature/dew point transmitter
Accuracy		2 3 5				2% accuracy 3% accuracy 5% accuracy
Housing			E N			European style wall mount North American style wall mount
Humidity/Dew Point Output				4		4-20 mA/0-5 VDC/0-10 VDC
Temperature Output					0 4 A B C D E F	None 4-20 mA/0-5 VDC/0-10 VDC 10K Ω @ 25°C thermistor type III 10K Ω @ 25°C thermistor type II 3K Ω @ 25°C thermistor 100 Ω RTD DIN 385 1K Ω RTD DIN 385 20K Ω @ 25°C thermistor
Options					LCD NIST	LCD display NIST traceable calibration certificate

ACCESSORIES	
Model	Description
A-449	Remote LCD display allows remote indication of select Dwyer wall mount transmitters for validation or certification purposes
SCD-PS	100 to 240 VAC/VDC to 24 VDC power supply



LEED® is a registered trademark of US Green Building Council.

# WALL MOUNT HUMIDITY/TEMPERATURE TRANSMITTER

2% or 3% Humidity Sensor, Passive Temperature Outputs

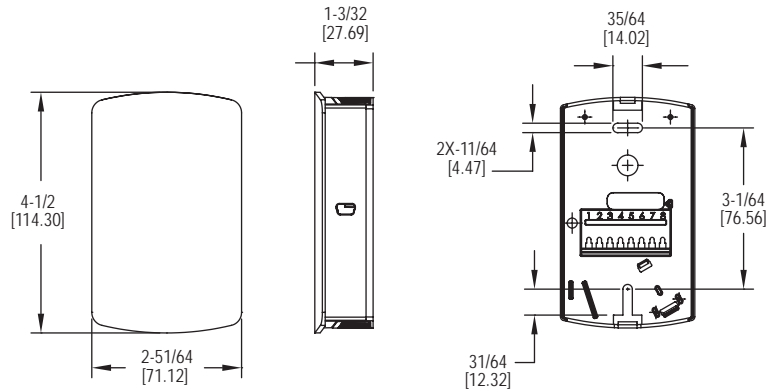

The **Series RHPLC Wall Mount Humidity/Temperature Transmitter** is a compact economical sensor for the building automation marketplace. The stylish housing is well vented to provide air flow across the sensor to improve measurement accuracy. Each unit utilizes a capacitive polymer sensing element to deliver a proportional analog output. A combination humidity and temperature model can be configured with current, voltage, RTD, or thermistor output. A wide selection of passive RTD or thermistor temperature sensors are available in this series.

**FEATURES/BENEFITS**

- 2% or 3% accuracy models
- Humidity only or temperature and humidity combo
- Wide selection of passive thermistor or RTD temperature sensors

**APPLICATIONS**

- Air economizers
- Room comfort monitoring

**SPECIFICATIONS**

**Sensor:** Capacitive polymer.  
**Relative Humidity Range:** 0-100% RH.  
**RH Accuracy:** ±2% 10 to 90% RH @ 25°C for 2% accuracy units; ±3% 20 to 80% RH @ 25°C for 3% accuracy units.  
**RH Hysteresis:** ±0.8%.  
**RH Repeatability:** ±0.1% typical.  
**Temperature Output Range:** -40 to 140°F (-40 to 60°C).  
**Passive Thermistor Temperature Sensor Accuracy:** ±0.36°F @ 77°F (±0.2°C @ 25°C).  
**Accuracy RTD Temp Sensor:** DIN Class B; ±0.3°C @ 0°C (±0.54°F @ 77°F).  
**Accuracy Current/Voltage Temperature Output:** ±0.9°F @ 72°F (±0.3°C @ 25°C).  
**Temperature Limits:** Operating: -40 to 140°F (-40 to 60°C); Storage: -40 to 176°F (-40 to 80°C).  
**Power Requirements:** 10-35 VDC for 4-20 mA or 0-5 VDC output; 15-35 VDC for 0-10 VDC output; 10-29 VAC for 0-5 VDC output; 15-29 VAC for 0-10 VDC output.  
**Response Time:** 8 s (τ<sub>63</sub>).  
**Electrical Connections:** Screw terminal block.  
**Drift:** <0.25% RH/year.  
**Enclosure Material:** Polycarbonate.  
**Weight:** 4.4 oz (125 g).  
**Agency Approvals:** CE.

MODEL CHART							
Example	RHPLC	-3	N	2	A	-FC	RHPLC-3N2A-FC
Series	RHPLC						Humidity/temperature transmitter
Accuracy		2					2% accuracy
		3					3% accuracy
Housing			N				North American style wall mount
Humidity Output				1			Current 4-20 mA
				2			Voltage 0-10 VDC
				3			Voltage 0-5 VDC
Temperature Output					0		None
					1		Current 4-20 mA
					2		Voltage 0-10 VDC
					3		Voltage 0-5 VDC
					A		10K Ω @ 25°C thermistor type III
					B		10K Ω @ 25°C thermistor type II
					C		3K Ω @ 25°C thermistor
					D		100 Ω RTD DIN 385
					E		1K Ω RTD DIN 385
					F		20K Ω @ 25°C thermistor
Options						FC	Factory calibration certificate (3% accuracy units)

ACCESSORIES	
Model	Description
SCD-PS	100-240 VAC/VDC to 24 VDC power supply
APT-40-5DN	AC power transformer, 120/208/240/277/480 VAC input, 24 VAC isolated output, 40 VA, dual hub

# HUMIDITY/TEMPERATURE TRANSMITTERS

Passive Temperature Outputs, Sintered Filter Options

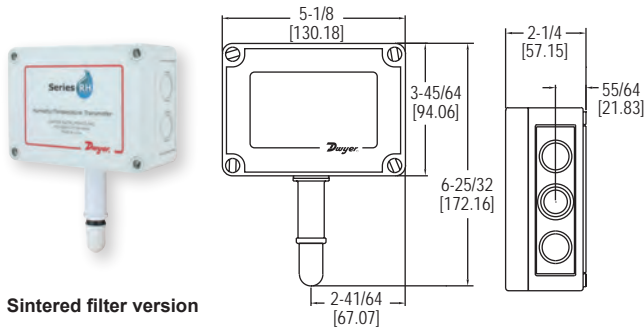

Sintered filter version

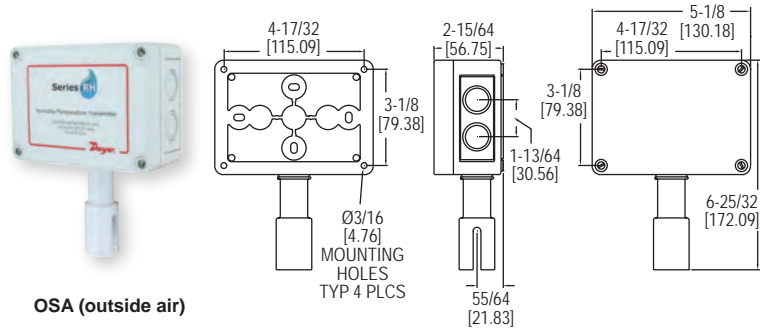

OSA (outside air)



Duct mount

Duct sintered

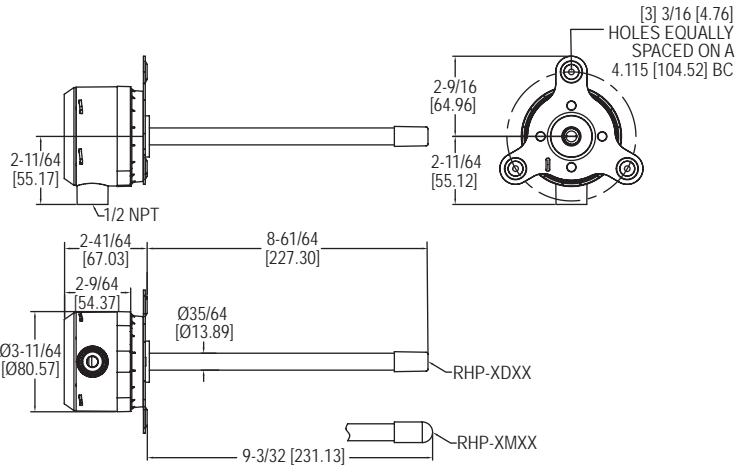

The **Series RHP Temperature and Humidity Transmitters** combine the voltage or current humidity transmitter output with a passive temperature thermistor or RTD output. Featuring polymer capacitance humidity sensors, models are available with 2%, 3% or 5% accuracies. Duct mounted transmitters are available with an optional two-line alpha numeric LCD display.

**FEATURES/BENEFITS**

- 2%, 3%, or 5% accuracy models
- Optional LCD display on duct mount models
- Radiation shield option for outdoor installation in direct sunlight

**APPLICATIONS**

- Air economizers
- Outdoor temperature and relative humidity reference
- Pool room humidity monitoring

MODEL CHART						
Example	RHP	-2	D	1	A -LCD	RHP-2D1A-LCD
Series	RHP					RH/passive temperature sensor transmitter
Accuracy		2 3 5				2% accuracy 3% accuracy 5% accuracy
Housing Type			D M O S R			Duct mount with filter Duct mount with HDPE filter OSA (outside air) OSA with sintered filter* Radiation shield
RH Output				1 2 3		4-20 mA 0-10 V 0-5 VDC
Temperature Sensor					0 1 2 3 A B C D E F	None 4-20 mA 0-10 VDC 0-5 VDC 10K @ 25°C thermistor type III 10K @ 25°C thermistor type II 3K @ 25°C thermistor 100 Ω RTD DIN 385 1K Ω RTD DIN 385 20K Ω @ 25°C thermistor
Options					LCD NIST	LCD display NIST traceable calibration shield

\*Use OSA with sintered filter models when purchasing Series RHRS radiation shield separately.

**SPECIFICATIONS**

**Relative Humidity Range:** 0 to 100% RH.  
**Temperature Range:** -40 to 140°F (-40 to 60°C).  
**Accuracy, RH:** RHP-2XXX ±2% 10-90% RH @ 25°C; RHP-3XXX ±3% 20-80% RH @ 25°C; RHP-5XXX ±5% 20-80% RH @ 25°C.  
**Accuracy, Thermistor Temp Sensor:** ±0.2°C @ 25°C (±0.36°F @ 77°F).  
**Accuracy, RTD Temp Sensor:** DIN Class B; ±0.3°C @ 0°C (±0.54°F @ 32°F).  
**Accuracy, Solid State Band Gap:** ±0.9°F @ 77°F (±0.3°C @ 25°C).  
**Hysteresis:** ±1%.  
**Repeatability:** ±0.1% typical.  
**Temperature Limits:** -40 to 140°F (-40 to 60°C).  
**Storage Temperature:** -40 to 176°F (-40 to 80°C).  
**Compensated Temperature Range:** -4 to 140°F (-20 to 60°C).  
**4 to 20 mA Loop Powered Models:** Power requirements: 10-35 VDC; Output signal: 4-20 mA.  
**0-5/10V Output Models:** Power requirements: 15-35 VDC or 15-29 VAC; Output signal: 0-10 V @ 5 mA max.  
**Solid State Band Gap Temperature Sensor Output Ranges:** Switch selectable, -20 to 140°F (-28.9 to 60°C); 0 to 100°F (-17.8 to 37.8°C); 40 to 90°F (4.4 to 32.3°C); -4 to 140°F (-20 to 60°C).  
**Response Time:** 15 s.  
**Electrical Connections:** Removable screw terminal block.  
**Conduit Connection:** Duct mount: 1/2" NPS; OSA: 1/2" (22.3 mm).  
**Drift:** < 1% RH/year.  
**RH Sensor:** Capacitance polymer.  
**Temperature Sensor:** Types 1, 2, 3: Solid state band gap; Curves A, B, C: Thermistor; Curves D, E: Platinum RTD DIN 385.  
**Enclosure:** Duct mount: PBT; OSA: Polycarbonate.  
**Enclosure Rating:** Duct mount: NEMA 4X (IP66) for housing only; OSA: NEMA 4X (IP66).  
**Display:** Duct mount only, optional 2-line alpha numeric, 8 characters/line.  
**Display Resolution:** RH: 0.1%; 0.1°F (0.1°C).  
**Weight:** Duct mount: .616 lb (.3 kg); OSA: 1 lb (.45 kg).  
**Agency Approvals:** CE.



# OUTSIDE AIR HUMIDITY RADIATION SHIELDS

6 or 10 Plate Design, Integral Pipe Mounting Kit

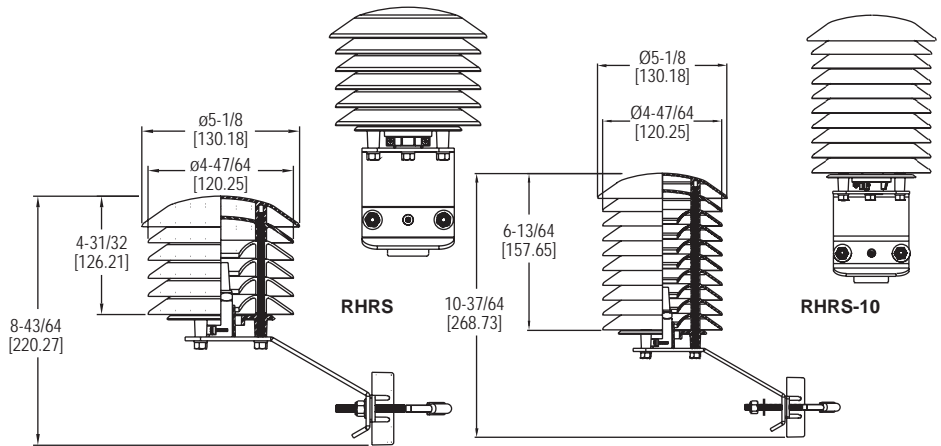
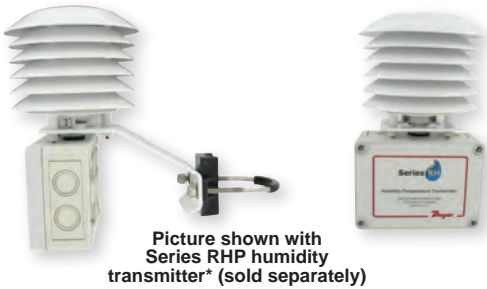

The Series RHRS Outside Air Humidity Radiation Shields protects outside air humidity transmitters from rain and radiated heat. With the curved shape and color of the plates, air flow is able to move across the sensor to keep radiated temperatures from rooftops and surrounding surfaces from affecting humidity readings.

**FEATURES/BENEFITS**

- Adjustable sensor mounting collar works with Dwyer RHP sintered filter outdoor air humidity transmitters or other RH devices
- Universal mount fits 3/4" to 1-1/2" pipe or flat surfaces

**APPLICATIONS**

- Building outside air reference
- Weather stations

MODEL CHART	
Model	Description
RHRS	6 plate radiation shield
RHRS-10	10 plate radiation shield

**Note:** Only sintered filter OSA models of Series RHP are compatible with the shield.

SERIES WHT

# WEATHER-RESISTANT HUMIDITY/TEMPERATURE TRANSMITTER

Compact Housing, Sintered Filter

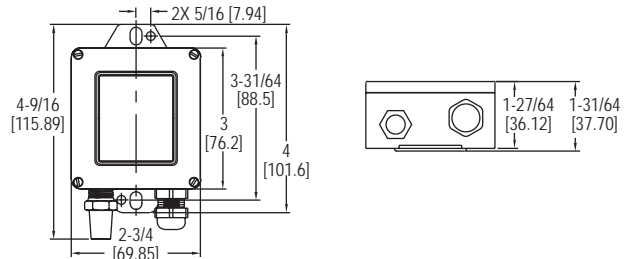

The compact Series WHT Weather-Resistant Humidity/Temperature Transmitter is designed to withstand the elements. A removable sintered filter protects the polymer capacitance sensor from solid objects that may come in contact with the transmitter. The transmitter is available with 4 to 20 mA or 0 to 10 VDC output signals for both temperature and humidity. This transmitter is ideal for measuring outside air temperature and humidity levels for air handling economizer applications.

**FEATURES/BENEFITS**

- RH or RH and temperature outputs
- Compact NEMA 3S construction

**APPLICATIONS**

- Air handling economizers
- Air environment monitoring in agriculture or livestock cultivation houses

MODEL CHART			
Model	Accuracy	RH Output	Temperature
WHT-310	3%	4 to 20 mA	None
WHT-311	3%	4 to 20 mA	4 to 20 mA
WHT-320	3%	0 to 10 VDC	None
WHT-322	3%	0 to 10 VDC	0 to 10 VDC
WHT-330	3%	0 to 5 VDC	None
WHT-333	3%	0 to 5 VDC	0 to 5 VDC
WHT-31A	3%	4 to 20 mA	10K $\Omega$ Type III
WHT-32A	3%	0 to 10 VDC	10K $\Omega$ Type III

**Note:** For 2% accuracy, change the leading 3 to a 2.  
**Example:** WHT-210.

SPECIFICATIONS	
<b>Relative Humidity Range:</b> 0 to 100% RH.	<b>0 to 10 V Output Models:</b> Power requirements: 15 to 35 VDC or 15 to 29 VAC; Output signal: 0 to 10 V @ 5 mA max.
<b>Temperature Range:</b> -40 to 140°F (-40 to 60°C).	<b>0 to 5 V Output Models:</b> Power requirements: 10 to 35 VDC or 10 to 29 VAC; Output signal: 0 to 5 V @ 5 mA max.
<b>Accuracy, RH:</b> $\pm 3\%$ 20 to 80% RH, $\pm 4\%$ @ 10-20%, 80 to 90%.	<b>Response Time:</b> 15 s.
<b>Accuracy, Temp Models with 4 to 20 mA Temp. Output:</b> $\pm 0.9^\circ\text{F}$ @ $72^\circ\text{F}$ ( $\pm 0.3^\circ\text{C}$ @ $25^\circ\text{C}$ ).	<b>Electrical Connections:</b> Removable screw terminal block.
<b>Accuracy, Temp Models with Passive Thermistor Temp Sensor:</b> $\pm 0.36^\circ\text{F}$ @ $77^\circ\text{F}$ ( $\pm 0.2^\circ\text{C}$ @ $25^\circ\text{C}$ ).	<b>Drift:</b> < 1% RH/year.
<b>Hysteresis, RH:</b> $\pm 1\%$ .	<b>RH Sensor:</b> Capacitance polymer.
<b>Repeatability, RH:</b> $\pm 0.1\%$ typical.	<b>Temperature Sensor:</b> 4 to 20 mA output, solid state band gap. Passive output: 10K @ $25^\circ\text{C}$ thermistor (Dwyer curve A).
<b>Temperature Limits:</b> -40 to 140°F (-40 to 60°C).	<b>Enclosure Rating:</b> Designed to meet NEMA 3S (IP54).
<b>Storage Temperature:</b> -40 to 176°F (-40 to 80°C).	<b>Weight:</b> 0.3 oz (8.5 g).
<b>Compensated Temperature Range, RH:</b> -4 to 140°F (-20 to 60°C).	<b>Agency Approvals:</b> CE.
<b>4 to 20 mA Loop Powered Models:</b> Power requirements: 10 to 35 VDC; Output signal: 4 to 20 mA.	





**SERIES RH-R**

# HUMIDITY/TEMPERATURE TRANSMITTER

Remote Mount, Field Replaceable Sensor Filter, Up to 16' Cable

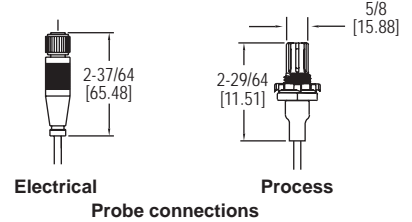
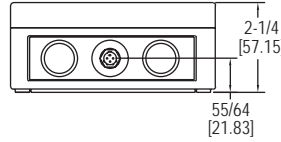
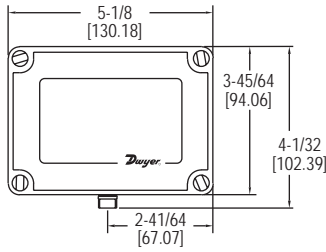

The **Series RH-R Humidity and Temperature Transmitter** is the ideal transmitter for those applications where space is limited. The compact sensor is protected by a removable filter. It can be mounted up to 16 feet away from the weatherproof base. The Series RH-R is ideal for environmental chambers, rubber bladder burst detection and air handler applications.

**FEATURES/BENEFITS**

- Cable lengths from 4 to 16'
- Remote housing allows for flexibility sensing where space may be limited

**APPLICATIONS**

- Process system monitoring
- Environmental chambers
- Air economizers

**SPECIFICATIONS**

**Service:** Dry clean air.  
**Relative Humidity Range:** 0 to 100% RH.  
**Temperature Range:** -40 to 140°F (-40 to 60°C).  
**Accuracy:** ±2% @ 10-90%.  
**Temperature Limits:** -40 to 140°F (-40 to 60°C).  
**Storage Temperature:** -40 to 176°F (-40 to 80°C).  
**Compensated Temperature Range:** -4 to 140°F (-20 to 60°C).

**Power Requirements:** 10-35 VDC.  
**Output Signal:** 4-20 mA loop powered.  
**Response Time:** Less than 15 s.  
**Electrical Connections:** Terminal block.  
**Conduit Connection:** 1/2" NPT.  
**Process Connection:** 1/2" NPSM.  
**Drift:** < 1%/year.  
**RH Sensor:** Capacitance polymer  
**Cable Length:** Up to 16'.  
**Housing Material:** Polycarbonate, aluminum enclosure.  
**Enclosure Rating:** NEMA 4X (IP66).

**MODEL CHART**

Model	Cable Length	Description	Output	Model	Cable Length	Description	Output
RHU-R004	4'	Humidity	Current	RHT-R004	4'	Humidity/temperature	Current
RHU-R008	8'	Humidity	Current	RHT-R008	8'	Humidity/temperature	Current
RHU-R012	12'	Humidity	Current	RHT-R012	12'	Humidity/temperature	Current
RHU-R016	16'	Humidity	Current	RHT-R016	16'	Humidity/temperature	Current

**SERIES 657**

# RELATIVE HUMIDITY/TEMPERATURE TRANSMITTERS

Dual Channel Design for Simultaneous 4 to 20 mA Output Signals



657

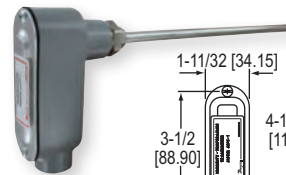
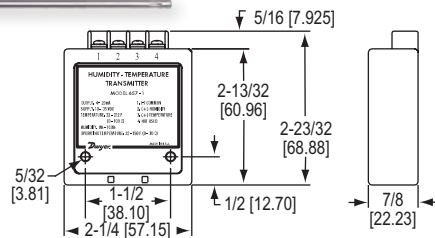

657C

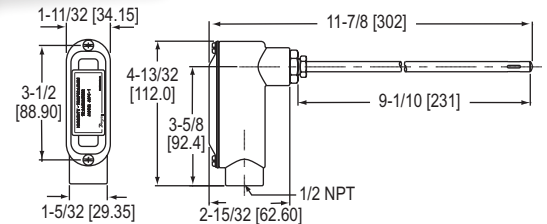

The **Series 657 Relative Humidity/Temperature Transmitters** provide two 4-20 mA channels to produce separate output signals for both relative humidity and temperature. These devices deliver ±2% accuracy for humidity and ±1°F for temperature measurements. Stainless steel probe can be easily mounted to most ductwork using either of the two optional kits below.

**FEATURES/BENEFITS**

- Polymer film humidity and thin film RTD temperature sensors offer highly reliable and stable measurements.
- Remote mount housing offers installation flexibility (657-1)
- Rugged die-cast aluminum housing is great for industrial applications (657C-1)

**APPLICATIONS**

- Cleanroom monitoring
- HVAC/building control monitoring

**MODEL CHART**

Model	Description
657-1	RH/temperature transmitter
657C-1	RH/temperature transmitter - conduit housing

**ACCESSORIES**

Model	Description
A-158	Split flange
A-159	Mounting gland



**SPECIFICATIONS**

**Service:** Dry clean air.  
**Range:** Relative humidity: 0 to 100%; Temperature: 32 to 212°F (0 to 100°C).  
**Accuracy:** Relative humidity: ±2% (10 to 90% RH), ±3% (0 to 10% and 90 to 100% RH); Temperature ±1°F (0.5°C).  
**Temperature Limits:** 32 to 140°F (0 to 60°C).  
**Pressure Limits:** 1 psi (.07 bar).  
**Compensated Temperature Range:** 32 to 140°F (0 to 60°C).  
**Power Requirements:** 10-35 VDC.  
**Output Signal:** 2 channels each 4-20 mA. Loop powered on the RH channel.  
**Electrical Connections:** 4 screw type terminals.  
**Mounting Orientation:** Mount in any position.  
**Probe:** 657-1: Stainless steel 5/16" x 10" (0.8 x 25.4 cm); 657C-1: 5/16" x 9-1/10" (0.8 x 23.1 cm).  
**Weight:** 657-1: 5.5 oz (156 g); 657C-1: 10 oz (284 g).

**OPTIONS**

To order add suffix:	Description
-NIST	NIST traceable humidity calibration certificate
<b>Example:</b> 657C-1-NIST	

# HAZARDOUS AREA HUMIDITY/TEMPERATURE TRANSMITTER

Intrinsically Safe or Explosion-Proof Models

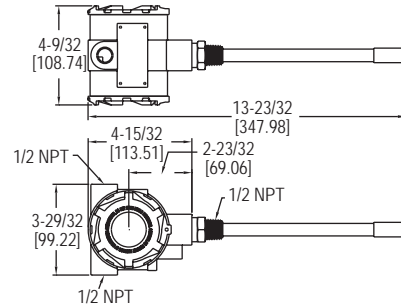

The Series HHT Hazardous Area Humidity/Temperature Transmitter takes accurate measurements in the harshest of environments. The explosion-proof model is offered with 4-20 mA output for humidity only. The intrinsically safe version is offered with 4-20 mA output for humidity and temperature, and do require an intrinsically safe barrier to meet hazardous area approvals.

**FEATURES/BENEFITS**

- FM approved explosion-proof and intrinsically safe models
- Integral LCD option
- Dual temperature and relative humidity output models

**APPLICATIONS**

- Process monitoring
- Offshore HVAC monitoring
- Dust and grain handling

MODEL CHART			
Model	Protection	Description	Display
HHT-EU	Explosion-proof	Humidity	No
HHT-IU	Intrinsically safe	Humidity	No
HHT-IT	Intrinsically safe	Humidity/temperature	No
HHT-EU-LCD	Explosion-proof	Humidity	Yes
HHT-IT-LCD	Intrinsically safe	Humidity/temperature	Yes

ACCESSORIES	
Model	Description
KFD0-SCS-EX1.55 A-287	Loop powered galvanic isolator Mounting bracket for pipe or surface mounting (Includes bracket and two 2" U-bolts)
A-450	Replacement sintered filter

**SPECIFICATIONS**

**Relative Humidity Range:** 0 to 100% RH.  
**Temperature Range:** -40 to 140°F (-40 to 60°C).  
**Accuracy:** ±2% 10 to 90% RH, ±0.9°F at 72°F (±0.3°C at 25°C).  
**Hysteresis:** ±1%.  
**Repeatability:** ±0.1% typical.  
**Temperature Limits:** -40 to 140°F (-40 to 60°C).  
**Storage Temperature:** -40 to 176°F (-40 to 80°C).  
**Compensated Temperature:** -40 to 140°F (-40 to 60°C).  
**Power Requirements:** For intrinsically safe models HHT-IX, 9.5-28 VDC. For explosion-proof models HHT-EX, 16.5-28 VDC.  
**Output Signal:** 4-20 mA, 2 channels for humidity/temperature models (loop power on RH).  
**Response Time:** 15 s.  
**Electrical Connections:** Screw terminal block.  
**Conduit Connection:** 1/2 female NPT.  
**Drift:** < 1% RH/year.  
**RH Sensor:** Capacitance polymer.  
**Temperature Sensor:** Solid state band gap.  
**Housing Material:** Aluminum.  
**Display:** Optional 2 line alpha numeric, 8 characters/line. Temperature display is °F/°C selectable.  
**Display Resolution:** RH: 0.1%; Temperature: 0.1°F (0.1°C).  
**Weight:** 2 lb 8 oz (1134 g).  
**Enclosure Rating:** NEMA 4X (IP66). Models HHT-EX: FM Explosion- Proof, Class I Div. 1 Group B, C, D, Class II Div. 1 Group E, F, G, Class III Div. 1; Models HHT-IX: FM Intrinsically Safe, Class I Div. 1 Group A, B, C, D, Class II Div. 1 Group E, F, G, Class III Div. 1 T4.  
**Agency Approvals:** CE, FM.

See page 366 (Model KFD0)

SERIES CDWP

# CARBON DIOXIDE TRANSMITTER

NDIR CO<sub>2</sub> Sensor with Universal Outputs in an Industrial Housing

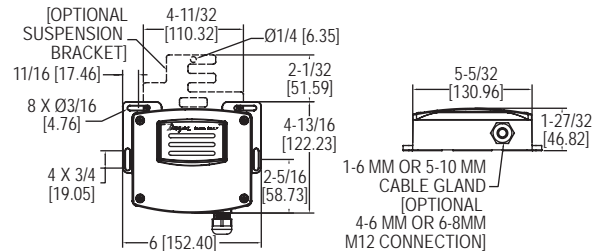

The Series CDWP Carbon Dioxide Transmitter accurately monitors the CO<sub>2</sub> concentration in industrial and indoor environments to help achieve energy savings. For increased sensor life and accuracy, a single-beam dual-wavelength non-dispersive infrared (NDIR) sensor is used to eliminate light source aging effects. This sensing technology provides the highest level of accuracy compared to Automatic Baseline Correction methods, which can unintentionally shift the calibration based on CO<sub>2</sub> levels and barometric pressure conditions.

MODEL CHART						
Example	CDWP	-05	W	-M4	-FC	CDWP-05W-M4
<b>Series</b>	CDWP					Carbon dioxide transmitter
<b>Range</b>		02 05 10				2000 PPM 5000 PPM 10000 PPM
<b>Mounting</b>			W H			Wall mount Suspended mount
<b>Electrical Connection</b>				C1 C5 M4 M6		Cable gland 1 to 6 mm cable Cable gland 5 to 10 mm cable M12 connection 4 to 6 mm cable M12 connection 6 to 8 mm cable
<b>Option</b>					FC	Factory calibration certificate

ACCESSORIES	
Model	Description
A-CDWP-L	Replacement lid with filter material
A-CDWP-H	Suspended mount bracket

**SPECIFICATIONS**

**Sensor:** Single beam, dual-wavelength NDIR.  
**Range:** CO<sub>2</sub>: 0 to 2000, 0 to 5000, or 0 to 10000 ppm (depending on model).  
**Accuracy:** CO<sub>2</sub>: ± 40 ppm ±3% of reading.  
**Temperature Dependence:** ±8 ppm/°C at 1100 ppm.  
**Non-Linearity:** 16 ppm.  
**Pressure Dependence:** 0.13% of reading per mm of Hg.  
**Response Time:** 300 s (T<sub>63</sub>).  
**Temperature Limits:** 32 to 122°F (0 to 50°C).  
**Humidity Limits:** 10 to 95% RH (non-condensing).  
**Power Requirements:** 16-35 VDC or 19-28 VAC.  
**Power Consumption:** Average: 2 w; Peak: 3.75 w.  
**Output:** Current: 4-20 mA (max. 500 Ω); Voltage: 0-5 VDC or 0-10 VDC (min. 500 Ω).  
**Enclosure Rating:** IP54.  
**Mounting Orientation:** Vertically, with electrical connections points downward.  
**Weight:** 26.24 oz (744 g).  
**Agency Approvals:** CE.

**FEATURES/BENEFITS**

- IP54 aluminum housing
- Gray finish tested to withstand 168 hour salt spray test
- Single-beam dual-wavelength sensor automatically corrects for aging effects
- Measures unfiltered light intensity directly and eliminates error from incorrect assumptions of gas concentration in theoretical logic assumption methods
- Universal outputs to work with any building management system

**APPLICATIONS**

- Animal husbandry
- Mechanical room
- CO<sub>2</sub> refrigeration monitoring
- Greenhouses



# CARBON DIOXIDE/TEMPERATURE TRANSMITTERS

NDIR CO<sub>2</sub> Sensor, Universal Outputs, Optional Relay

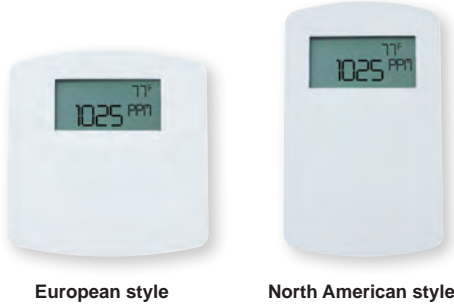

European style

North American style



Duct

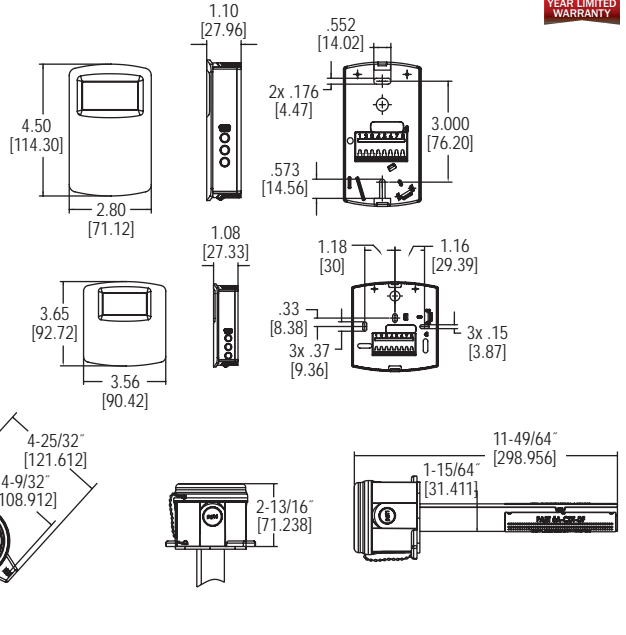

The **Series CDT Carbon Dioxide and Temperature Transmitters** accurately monitor the CO<sub>2</sub> concentration and temperature in indoor environments to help achieve energy savings. For increased sensor accuracy, a single beam dual wavelength non-dispersive infrared (NDIR) sensor is used to automatically correct the measurement in both occupied\* and unoccupied buildings against light source aging effects. The single beam dual wavelength sensor technology provides the highest level of accuracy compared to Automatic Baseline Correction methods which can unintentionally shift the calibration based on CO<sub>2</sub> levels and barometric pressure conditions. In order to achieve a higher level of accuracy, the Series CDT includes digital barometric pressure adjustment and the ability to field-calibrate the sensor.

For applications that require visual indication, the wall mount configurations of the Series CDT can be ordered with an integral LCD display. Push-buttons are standard on all configurations of the transmitters for access to the menu structure, but wall mount configurations can be ordered without the buttons. To prevent tampering, the action of the buttons can be locked out using an internal dip switch selection.

**FEATURES/BENEFITS**

- Single beam dual wavelength NDIR sensor eliminates draft due to light source aging
- Integral passive temperature outputs reduce number of devices mounted in the space
- Service display tool available for models without an integral LED
- Optional integral display and relay output

**APPLICATIONS**

- Demand control ventilation in schools, office buildings, hospitals, and other indoor environments
- LEED® certification

\*For buildings occupied 24 hours per day, it is recommended that calibration be verified every 6 to 12 months depending on application.

**SPECIFICATIONS**

**Sensor:** Single beam, dual wavelength NDIR.  
**Range:** CO<sub>2</sub>: 0 to 2000 or 0 to 5000 ppm (depending on model); Temperature: 32 to 122°F (0 to 50°C).  
**Accuracy:** CO<sub>2</sub>: ±40 ppm ±3% of reading; Temperature: ±1°C @ 25°C.  
**Temperature Dependence:** ±8 ppm/°C at 1100 ppm.  
**Non-Linearity:** 16 ppm.  
**Pressure Dependence:** 0.13% of reading per mm of Hg.  
**Response Time:** 2 min for 99% step change.  
**Duct Air Velocity Range:** 0-4000 FPM (20.32 m/s).  
**Temperature Limits:** 32 to 122°F (0 to 50°C).  
**Humidity Limits:** 10 to 95% RH (non-condensing).  
**Power Requirements:** 16-35 VDC or 19-28 VAC.  
**Power Consumption:** Average: 2 w; Peak: 3.75 w.  
**Output:** Current: 4-20 mA (max. 500 Ω); Voltage: 0-5 VDC or 0-10 VDC (min. 500 Ω); Relay: SPST NO rated 2 A @ 30 VDC.  
**Weight:** 4.4 oz (125 g).  
**Enclosure Rating:** Duct mount: NEMA 4X (IP66) for housing only; Wall mount: IP20.  
**Agency Approvals:** CE.

Carbon Dioxide Transmitters

MODEL CHART						
Example	CDT	-2	N	4	4	-LCD CDT-2N44-LCD
Series	CDT					Carbon dioxide/temperature transmitter
Range		2 5				0 to 2000 ppm CO <sub>2</sub> range 0 to 5000 ppm CO <sub>2</sub> range
Configuration			N E D			North American style wall mount European style wall mount Duct mount
CO <sub>2</sub>				4		4-20 mA / 0 to (5 or 10) VDC
Temperature Output					0 4 A B C D E F	None 4-20 mA / 0 to (5 or 10) VDC 10 KΩ NTC thermistor type III 10 KΩ NTC thermistor type II 3 KΩ NTC thermistor Pt100 Ω RTD Pt1000 Ω RTD 20 KΩ NTC thermistor
Options						FC Factory calibration certificate LCD LCD display (wall only) RLY Relay NBC No buttons (wall only)

ACCESSORIES	
Model	Description
GCK-200CO-2000CO2	Calibration gas kit includes a 99.99% nitrogen gas cylinder for calibrating the zero point and a 200 PPM CO / 2000 PPM CO <sub>2</sub> gas cylinder for calibrating the span point on Dwyer's gas sensing transmitters
A-449	Remote LCD display allows remote indication of select Dwyer® wall mount transmitters for validation or certification purposes
A-449A	Remote LCD display with buttons allows remote indication and calibration of select Dwyer® wall mount transmitters for validation and certification purposes
A-CDT-KIT	Accessory kit including terminal block and power supply



GCK-200CO-2000CO2



A-449

LEED® is a registered trademark of the U.S. Green Building Council.



# COMMUNICATING CARBON DIOXIDE DETECTORS

Measures CO<sub>2</sub>, Humidity, Temperature, Temperature Set Point, and Override

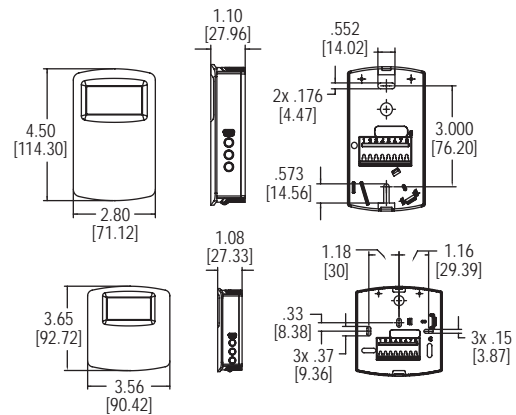

The **Series CDTA Communicating Carbon Dioxide Detectors** combine the function of three room sensors into a single, compact housing. Parameters include carbon dioxide, humidity, temperature, and temperature set point with override. By having field selectable Modbus® and BACnet Communications, only four wires are needed for power and the communication signal. The communicating detectors can be daisy chained together to further reduce installation cost. In order to reduce the set up time, the RS-485 MAC address is set up using on board dip switches. A second set of dip switches are used to select whether output is Modbus® RTU or BACnet MS/TP communication protocols and to limit access to the set up menu. Like our Series CDT Carbon Dioxide Transmitter, the Series CDTA uses a Single Beam Dual Wavelength Non-Dispersive Infrared (NDIR) sensor to measure the carbon dioxide level. This technology can be used in installations that will be occupied 24 hours per day. For improved accuracy, the transmitter can be field calibrated to the environmental conditions of the installation. Also, the barometric pressure can be programmed to correct for altitude. The humidity uses a capacitive polymer sensor and the temperature is measured using a 10KΩ thermistor sensor. The humidity sensor is field replaceable without the need for additional calibration. Optional local and remote displays are available to display any of the parameters. For applications in which the building occupants aren't familiar with CO<sub>2</sub> concentrations, the LCD can be programmed to display temperature, humidity, or temperature set point instead.

SPECIFICATIONS	
<b>Sensor (CO<sub>2</sub>):</b>	Single beam, dual wavelength NDIR; Humidity: Capacitive polymer; Temperature: 10KΩ thermistor.
<b>Range:</b>	CO <sub>2</sub> : 0 to 2000 or 5000 PPM CO <sub>2</sub> (depending on model); Humidity: 0 to 100% RH; Temperature: 32 to 122°F (0 to 50°C).
<b>Accuracy:</b>	CO <sub>2</sub> : ±40 ppm ±3% of reading; RH: ±2% (10 to 90% RH); Temperature: ±1°C @ 25°C.
<b>Temperature Dependence (CO<sub>2</sub>):</b>	±8 ppm / °C at 1100 ppm.
<b>Non-Linearity (CO<sub>2</sub>):</b>	16 ppm.
<b>Pressure Dependence (CO<sub>2</sub>):</b>	0.13% of reading per mm of Hg.
<b>Response Time (CO<sub>2</sub>):</b>	2 min. for 99% step change.
<b>Temperature Limits:</b>	32 to 122°F (0 to 50°C).
<b>Humidity Limits:</b>	10 to 95% RH (non-condensing).
<b>Power Requirements:</b>	10-42 VDC / 10-30 VAC.
<b>Power Consumption:</b>	Average: 0.5 watts; Peak: 1.2 watts.
<b>Output:</b>	2-wire RS-485, Modbus® RTU or BACnet MS/TP communication protocol.
<b>Weight:</b>	4.4 oz (125 g).
<b>Enclosure Rating:</b>	IP20.
<b>Agency Approvals:</b>	BTL, CE.

### FEATURES/BENEFITS

- Digital Intelligent Temperature Compensation Algorithm (DITCA™) corrects for errors due to self heating effects of combination wall sensors
- Field selectable Modbus® and BACnet communications reduces wiring
- Single beam dual wavelength CO<sub>2</sub> sensor
- Replaceable humidity/temperature sensor
- Physical hardware lockout
- Optional remote display tool

### APPLICATIONS

- Demand control ventilation in schools, office buildings, hospitals, and other indoor environments
- LEED® certification

MODEL CHART			
Model	CO <sub>2</sub> Concentration	Housing Style	Display
CDTA-2N000	2000 PPM	North American	No
CDTA-2N000-LCD	2000 PPM	North American	Yes
CDTA-2E000	2000 PPM	European	No
CDTA-2E000-LCD	2000 PPM	European	Yes
CDTA-5N000	5000 PPM	North American	No
CDTA-5N000-LCD	5000 PPM	North American	Yes
CDTA-5E000	5000 PPM	European	No
CDTA-5E000-LCD	5000 PPM	European	Yes

OPTIONS	
To order add suffix:	Description
-FC	Factory calibration certificate
<b>Example:</b> CDTA-2N000-FC	

ACCESSORIES	
Model	Description
<b>GCK-200CO-2000CO2</b>	Calibration gas kit includes a 99.99% nitrogen gas cylinder for calibrating the zero point and a 200 PPM CO / 2000 PPM CO <sub>2</sub> gas cylinder for calibrating the span point on Dwyer's gas sensing transmitters
<b>A-449</b>	Remote LCD display allows remote indication of select Dwyer® wall mount transmitters for validation or certification purposes
<b>A-449A</b>	Remote LCD display with buttons allows remote indication and calibration of select Dwyer® wall mount transmitters for validation and certification purposes
<b>A-CDT-KIT</b>	Accessory kit including terminal block and power supply



GCK-200CO-2000CO2



A-449

LEED® is a registered trademark of the U.S. Green Building Council. Modbus® is a registered trademark of Schneider Automation, Inc.

# CARBON DIOXIDE/RH/TEMPERATURE TRANSMITTERS

NDIR CO<sub>2</sub> Sensor, Universal CO<sub>2</sub>/RH Outputs, Optional Relay

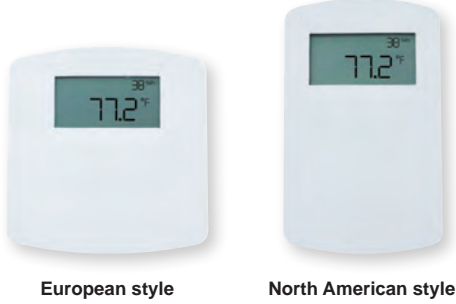

European style

North American style



Duct

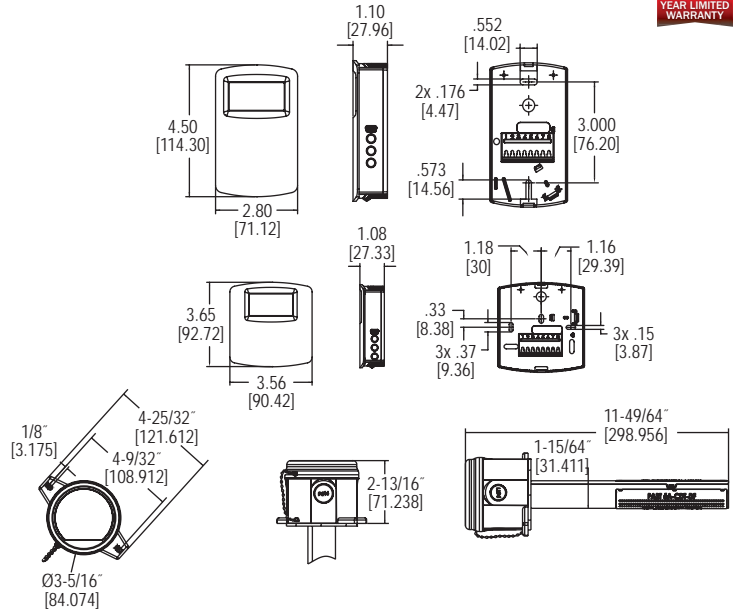

The Series CDTR Carbon Dioxide, Relative Humidity and Temperature Transmitters reduce the number of sensors mounted on a wall or in a duct. By combining CO<sub>2</sub>, RH, and temperature in one device, system integrators are able to reduce installation time while lowering material cost at the same time.

Like our popular Series CDT Carbon Dioxide Transmitter, a single beam dual wavelength non-dispersive infrared (NDIR) sensor is used to automatically correct the measurement in both occupied\* and unoccupied buildings against light source aging effects. In order to achieve the best possible accuracy, the Series CDTR also includes digital barometric pressure adjustment and the ability to field calibrate the sensor.

Universal outputs for both carbon dioxide and relative humidity allow users to select the transmitter output to be 4-20 mA, 0-5 VDC, or 0-10 VDC to work with virtually any building management controller. Additionally, passive thermistor or RTD sensor can be ordered for a temperature output.

For applications that require visual indication, the wall mount configurations of the Series CDTR can be ordered with an integral LCD display. The display can be configured to display temperature only, relative humidity only, CO<sub>2</sub> only, CO<sub>2</sub> and humidity, or CO<sub>2</sub> and temperature. Push-buttons are standard on all configurations of the transmitters for access to the menu structure. To prevent tampering, the action of the buttons can be locked out using an internal jumper selection.

**FEATURES/BENEFITS**

- Digital Intelligence Temperature Compensation Algorithm (DITCA™) eliminates error due to the self heating effects of wall mount combination devices.
- Single beam dual wavelength NDIR CO<sub>2</sub> sensor
- Replaceable humidity/temperature sensors
- Physical hardware lockout
- Service display tool available for duct mount and wall mount units without an LCD
- Relay output option

**APPLICATIONS**

- Demand control ventilation in schools, office buildings, hospitals, and other indoor environments
- LEED® certification

\*For buildings occupied 24 hours per day, it is recommended that calibration be verified every 6 to 12 months depending on application.

**SPECIFICATIONS**

**Range:** CO<sub>2</sub>: 0 to 2000 or 0 to 5000 ppm (depending on model); Relative humidity: 0 to 100%; Temperature: 32 to 122°F (0 to 50°C).  
**Accuracy:** ±40 ppm + 3% of reading (CO<sub>2</sub>); ±2% (RH).  
**Temperature Dependence:** ±8 ppm / °C at 1100 ppm.  
**Non-Linearity:** 16 ppm.  
**Pressure Dependence:** 0.13% of reading per mm of Hg.  
**Response Time:** 2 minutes for 99% step change.  
**Temperature Limits:** 32 to 122°F (0 to 50°C).  
**Duct Air Velocity Range:** 0-4000 FPM (20.32 m/s)  
**Humidity Limits:** 10 to 95% RH (non-condensing).  
**Power Requirements:** 16-35 VDC / 19-28 VAC.  
**Power Consumption:** Average: 2 watts; Peak: 3.75 watts.  
**Sensor:** Single beam, dual wavelength NDIR.  
**Output:** Current: 4-20 mA (max 500 Ω); Voltage: 0-5 VDC or 0-10 VDC (min 500 Ω); Relay: SPST NO 2 A @ 30 VDC; RTD or thermistor per r-t curves (depending on model).  
**Weight:** 5.6 oz (158.8 g).  
**Enclosure Rating:** Duct mount: NEMA 4X (IP66) for housing only; Wall mount: IP20.  
**Agency Approvals:** CE.

**MODEL CHART**

Example	CDTR	-2	N	4	A	4	-LCD	CDTR-2N4A4-LCD
<b>Series</b>	CDTR							Carbon dioxide/RH/temperature transmitter
<b>Range</b>		2 5						0 to 2000 ppm CO <sub>2</sub> range 0 to 5000 ppm CO <sub>2</sub> range
<b>Configuration</b>			N E D					North American style wall mount European style wall mount Duct mount
<b>CO<sub>2</sub> Output</b>				4				4-20 mA / 0 to (5 or 10) VDC
<b>Temperature Output</b>					0 A B C D E F			None 10K Ω NTC thermistor type III 10K Ω NTC thermistor type II 3K Ω NTC thermistor Pt100 Ω RTD Pt1000 Ω RTD 20K Ω NTC thermistor
<b>RH Output</b>						4		4-20 mA / 0 to (5 or 10) VDC
<b>Options</b>							FC LCD RLY NBC	Factory calibration certificate LCD display (wall only) Relay No buttons (wall only)

**ACCESSORIES**

Model	Description
<b>GCK-200CO-2000CO2</b>	Calibration gas kit includes a 99.99% nitrogen gas cylinder for calibrating the zero point and a 200 PPM CO / 2000 PPM CO <sub>2</sub> gas cylinder for calibrating the span point on Dwyer's gas sensing transmitters
<b>A-449</b>	Remote LCD display allows remote indication of select Dwyer® wall mount transmitters for validation or certification purposes
<b>A-449A</b>	Remote LCD display with buttons allows remote indication and calibration of select Dwyer® wall mount transmitters for validation and certification purposes
<b>A-CDT-KIT</b>	Accessory kit including terminal block and power supply

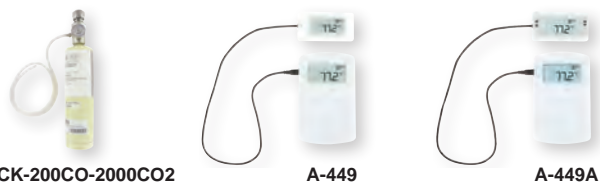

GCK-200CO-2000CO2

A-449

A-449A

LEED® is a registered trademark of the U.S. Green Building Council.

# CARBON DIOXIDE/VOLATILE ORGANIC COMPOUND TRANSMITTERS

Simultaneously Outputs Both CO<sub>2</sub> / VOC



AIR QUALITY



North American style

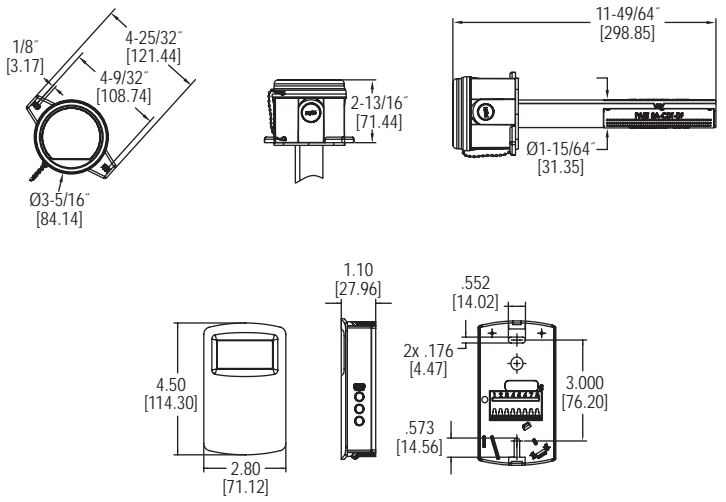

The **Series CDTV Carbon Dioxide/Volatile Organic Compound Transmitters** reduce energy cost in buildings by lowering the amount of conditioned air based on the occupancy of the space. By sensing both CO<sub>2</sub> and VOC, the transmitter can detect fumes that may need to be exhausted during lower occupancy periods.

**FEATURES/BENEFITS**

- Combination VOC and CO<sub>2</sub> outputs reduce labor and material costs
- Single beam dual wavelength NDIR CO<sub>2</sub> sensor allows for use in spaces that may be occupied 24 hours a day
- VOC output is correlated to be equivalent to CO<sub>2</sub> measurements
- Ventilate using ASHRAE's occupancy-based VRP Algorithm

**APPLICATIONS**

- HVAC applications in hospitals, schools, and commercial buildings
- Demand control ventilation
- Odor control
- Waiting rooms or other spaces that may be occupied 24 hours a day

MODEL CHART							
Example	CDTV	-2	D	4	A	4	-RLY CDTV-2D4A4-RLY
Series	CDTV						Carbon dioxide/VOC transmitter
Range		2 5					0 to 2000 ppm CO <sub>2</sub> range 0 to 5000 ppm CO <sub>2</sub> range
Configuration			D N				Duct North American style wall mount
CO <sub>2</sub> Output				4			4-20 mA / 0 to (5 or 10) VDC
Temperature Output					0 A B C D E F		None 10 KΩ NTC thermistor type III 10 KΩ NTC thermistor type II 3 KΩ NTC thermistor Pt100 Ω RTD Pt1000 Ω RTD 20 KΩ NTC thermistor
VOC Output						4	4-20 mA / 0 to (5 or 10) VDC
Options						RLY FC LCD COC	Relay Factory calibration certificate LCD display (wall only) Certificate of calibration

**SPECIFICATIONS**

**Range:** CO<sub>2</sub>: 0 to 2000 or 0 to 5000 ppm (depending on model); VOC: 0 to 2000 ppm CO<sub>2</sub> equivalent.  
**Accuracy:** CO<sub>2</sub>: ±40 ppm ±3% of reading.  
**Temperature Dependence:** ±8 ppm / °C at 1100 ppm.  
**Non-Linearity:** CO<sub>2</sub>: 16 ppm.  
**Pressure Dependence:** CO<sub>2</sub>: 0.13% of reading per mm of Hg.  
**Response Time:** CO<sub>2</sub>: 2 minutes for 99% step change; VOC: 5 minutes.  
**Temperature Limits:** 32 to 122°F (0 to 50°C).  
**Duct Air Velocity Range:** 0-4000 FPM (20.32 m/s).  
**Power Requirements:** 16-35 VDC / 19-28 VAC.  
**Power Consumption:** Average: 2 watts; Peak: 3.75 watts.  
**Sensor:** CO<sub>2</sub>: Single-beam, dual-wavelength NDIR; VOC: MEMS metal oxide semiconductor.  
**Output:** Current: 0-20 mA, 4-20 mA, 0-10 mA, or 2-10 mA (depending on selection jumper, max 500 Ω); Voltage: 0-10 VDC, 2-10 VDC, 0-5 VDC, or 1-5 VDC (depending on selection jumper, min 500 Ω); Relay: SPST NO 2A @ 30 VDC.  
**Weight:** 5.6 oz (158.8 g).  
**Enclosure Rating:** Duct mount: NEMA 4X (IP66) for housing only; Wall mount: IP20.  
**Agency Approvals:** CE.

Carbon Dioxide Transmitters



SERIES GSTA & GSTC

# CARBON MONOXIDE/NITROGEN DIOXIDE GAS TRANSMITTERS

High Accuracy Electrochemical Sensor, Universal Output or BACnet or Modbus® Communication Protocol Options



Wall mount with LCD



Wall mount without LCD



Duct mount

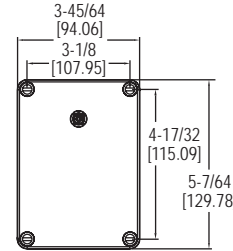

Wall mount

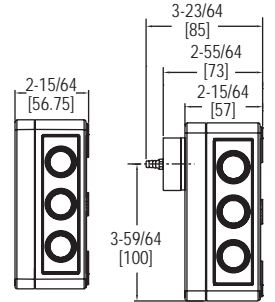

Duct mount



The **Series GSTA & GSTC Carbon Monoxide/Nitrogen Dioxide Gas Transmitters** monitor gas concentrations in mechanical rooms, underground parking garages and loading docks. The carbon monoxide transmitter is used to measure the exhaust of gasoline engines, while the nitrogen dioxide transmitter is used for diesel engines. The Series GSTA features field selectable current and voltage outputs while the Series GSTC features BACnet or Modbus® communication protocol, allowing gas sensing solutions that can be used with almost any building management controller.

**FEATURES/BENEFITS**

- Industrial grade replaceable CO or NO<sub>2</sub> sensors
- Field selectable current or voltage output on GSTA models, and field selectable BACnet or Modbus® communication on GSTC models
- Integral LCD display option
- Service display tool for set-up and calibration of models without a LCD

**APPLICATIONS**

- Garage or loading dock ventilation
- Mechanical room monitoring

MODEL CHART			
Example	GSTA	-C	GSTA-C
Series	GSTA GSTC		Field selectable analog outputs Field selectable BACnet or Modbus®
Gas Sensed		C N	CO, carbon monoxide NO <sub>2</sub> , nitrogen dioxide
Options		- D LCD	Wall mount without LCD Duct mount Wall mount with LCD

ACCESSORIES	
Model	Description
GCK-200CO-2000CO2	Calibration gas
A-449	Remote LCD display
A-505	CO replacement sensor
A-506	NO <sub>2</sub> replacement sensor
A-507	Calibration adapter

**SPECIFICATIONS**

**Sensor:** Field replaceable electrochemical, 4 years typical lifespan.  
**Range:** CO: 0 to 500 PPM, NO<sub>2</sub>: 10 PPM.  
**Output Drift:** <5% per year in air.  
**Coverage Area:** 5000 to 7500 sq ft typical.  
**Accuracy:** CO: 2% FS, NO<sub>2</sub>: 3% FS, at the time of calibration.  
**Resolution:** CO: 1 PPM; NO<sub>2</sub>: 0.1 PPM.  
**Temperature Limits:** -4 to 122°F (-20 to 50°C).  
**Storage Temperature:** For best sensor life, 32 to 68°F (0 to 20°C).  
**Humidity Limits:** 15 to 90% RH constant; 0 to 99% RH intermittent.  
**Response Time:** <45 s to 90% CO, <25 s to 90% NO<sub>2</sub>.  
**Span and Zero Adjustment:** Via push-button, using optional A-449 display. Zero only via BACnet or MODBUS® communication protocol.  
**Housing:** UV resistant glass filled polycarbonate.  
**Output Signals:** GSTA: Switch selectable 4-20 mA (loop powered), 0-5 V @ 5 mA, or 0-10 V @ 5 mA; Switch selectable 0-5 V / 1-5 V and 0-10 V / 2-10 V; Switch selectable normal or reverse output; GSTC: BACnet MS/TP, Modbus® RTU, or Modbus® ASCII (switch selectable) communication protocol.  
**Power Requirements:** GSTA: Current output: 10-35 VDC, Voltage output: 15-35 VDC or 15-29 VAC; GSTC: 10-36 VDC or isolated 21.6-33 VAC.  
**Electrical Connection:** Removable terminal block, knock outs for conduit fitting.  
**Calibration:** Via pushbuttons using A-449 auxiliary display. Span gas concentration is field selectable.  
**Enclosure Rating:** IP64.  
**Weight:** 1 lb (0.45 kg).  
**Agency Approvals:** CE.





# CARBON MONOXIDE TRANSMITTERS

Current/Voltage Selectable Output, 200 PPM Range



AIR QUALITY

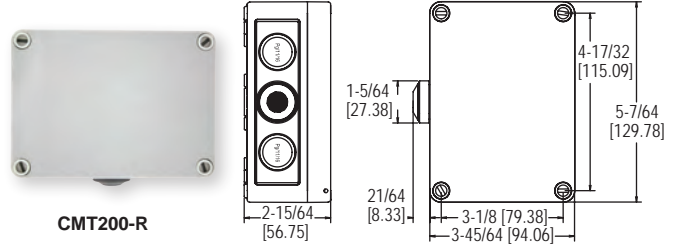
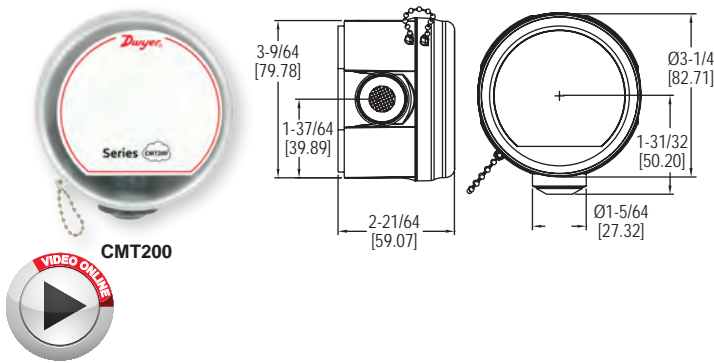

The Series CMT200 Carbon Monoxide Transmitters provides a field selectable current or voltage output that is proportional to the gas concentration in underground parking garages, vehicle maintenance facilities, or mechanical rooms.

**FEATURES/BENEFITS**

- Field selectable current or voltage outputs
- Replaceable sensor
- Field calibration kits

**APPLICATIONS**

- Garage ventilation
- Mechanical room monitoring

MODEL CHART	
Model	Description
CMT200	Carbon monoxide transmitter
CMT200-R	Carbon monoxide transmitter with rugged housing

ACCESSORIES	
Model	Description
GCK-200CO-2000CO2	Calibration gas
A-505	Replacement Carbon Monoxide Sensor
A-507A	Calibration adaptor

**SPECIFICATIONS**

**Sensor:** Field replaceable electrochemical, 4 year typical lifespan.  
**Range:** 0 to 200 ppm.  
**Coverage Area:** 5000 to 7000 sq. ft. typical.  
**Accuracy:** ±2% FS at the time of calibration.  
**Output Drift:** <5% per year in air.  
**Temperature Limits:** -4 to 122°F (-20 to 50°C).  
**Storage Temperature:** For best sensor life, 32 to 68°F (0 to 20°C).  
**Humidity Limits:** 15 to 90% RH constant; 0 to 99% RH intermittent.  
**Response Time:** <45 s to 90% of final value.  
**Calibration:** 15 turn span and zero adjustment potentiometers.  
**Housing:** UV resistant polycarbonate.  
**Output:** Jumper selectable 4-20 mA (loop powered) or 2-10 V (load must be >50 KΩ).  
**Power Requirements:** Current Output: 18-28 VDC; Voltage Output: 18-28 VDC/VAC, reverse polarity protected.  
**Electrical Connection:** Removable terminal block, includes two PG11 and one PG 16 knockouts for conduit fitting.  
**Weight:** 0.28 lb (0.11 kg).  
**Agency Approvals:** CE.

SERIES CMS300

# CARBON MONOXIDE TRANSMITTER AND SWITCH

Current/Voltage Selectable Output, Jumper Selectable SPDT Relay Contact



Gas Sensing Transmitters



The Series CMS300 Carbon Monoxide Transmitter and Switch provides a field selectable current or voltage output that is proportional to the carbon monoxide concentration in underground parking garages, vehicle maintenance facilities, or mechanical rooms. An integral relay can be used for alarm conditions and is configured with preset jumper selectable ranges of 25, 60, or 150 PPM. Field calibration can be done by using Model GCK-200CO-2000CO2 calibration gas, Model A-507 calibration adapter, and the on board zero and span potentiometers.

**FEATURES/BENEFITS**

- Field selectable current or voltage analog outputs
- Integral SPDT relay contact for low or high alarm
- Jumper selectable alarm set points of 25, 60, or 150 PPM
- UL recognized carbon monoxide sensing element
- Field calibration kits

**APPLICATIONS**

- Garage or loading dock ventilation
- Vehicle maintenance facilities
- Mechanical room monitoring

**SPECIFICATIONS**

**Sensor:** Electrochemical, 5 years typical lifespan.  
**Range:** 0-300 PPM.  
**Output Drift:** <5% per year in air.  
**Temperature Effect:** ±2% over range.  
**Coverage Area:** 7,500 ft<sup>2</sup> (700 m<sup>2</sup>) or 50 ft (15 m) radius.  
**Accuracy:** ±5 PPM or 5% of reading for 0-300 PPM (whichever is greater).  
**Resolution:** 1 PPM.  
**Temperature Range:** -4 to 122°F (-20 to 50°C).  
**Storage Temperature:** For best sensor life, 32°F to 68°F (0 to 20°C).  
**Humidity Range:** 15-90% RH constant; 0-99% RH intermittent.  
**Response Time:** <45 seconds to 90% of final value.  
**Calibration:** 15 turn span and zero adjustment potentiometers.  
**Housing:** UV resistant glass filled polycarbonate.  
**Analog Output:** Jumper selectable 4-20 mA (loop powered) or 2-10 V (max. load 2K Ω).  
**Enclosure Rating:** IP64.  
**Weight:** 1 lb (0.45 kg).  
**Switch Type:** Single-pole double-throw (SPDT).  
**Electrical Rating:** 30 VAC/VDC. N/O = 5 A. N/C = 3 A.  
**Set Point:** Jumper selectable 25, 60, or 150 PPM.  
**Set Point Differential/Hysteresis:** 3% of scale.  
**Relay Action:** Factory set for direct acting.  
**Agency Approvals:** Sensor is UL recognized component for ANSI/UL-2034, UL-2075, E340403, CE.

MODEL CHART	
Model	Description
CMS300	Carbon monoxide transmitter and switch

ACCESSORIES	
Model	Description
GCK-200CO-2000CO2	Calibration gas
A-507	Calibration adapter

# OCCUPANCY SENSORS

Wide Viewing Angle, Easy To Install

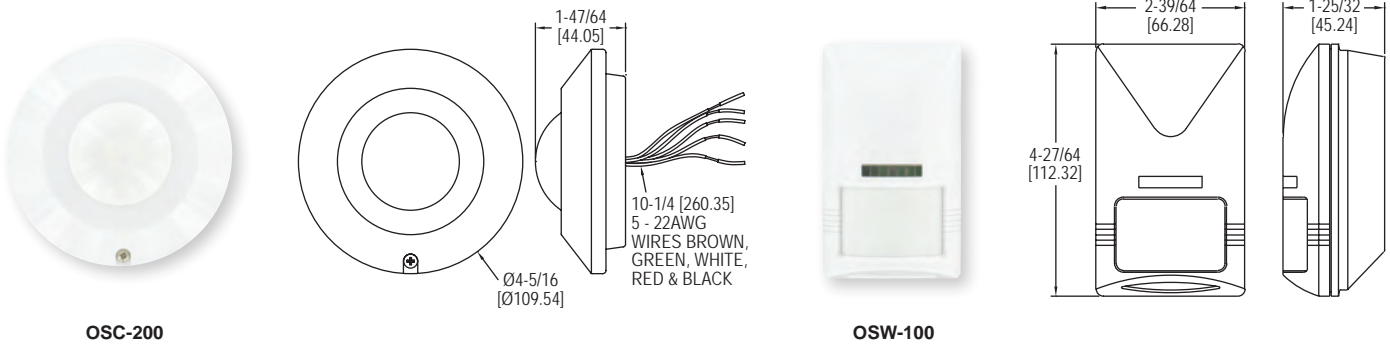

The **Model OSC-200 Occupancy Sensors** help to automate building control systems. A spherical Fresnel lens provides a 360° detection zone with the use of infrared technology.

The **Model OSW-100 Occupancy Sensor** is an infrared sensor designed to help automate building control systems. The Model OSW-100 has a wide 110° viewing angle to capture movement up to 49.2' (15 m) away.

**FEATURES/BENEFITS**

- Delay processor suppresses switch activation during momentary occupancy

**APPLICATIONS**

- Lighting control
- Building energy conservation

MODEL CHART	
Model	Description
OSC-200	Omnidirectional occupancy sensor
OSW-100	Wall mount occupancy sensor

SPECIFICATIONS
<b>Infrared Sensor:</b> Dual element.
<b>Range:</b> OSC-200: 34.4' (10.5 m) diameter at 13.8' (4.2 m) mount height; OSW-100: 49.2' (15 m).
<b>Detectable Speed:</b> 0.33 to 9.8 ft/s (0.1 to 3.0 m/s).
<b>Control Output Rating:</b> SPDT, 0.2 A @ 30 VDC.
<b>Ambient Operating Temperature:</b> -4 to 140°F (-20 to 60°C).
<b>Power Consumption:</b> Standby: 5 mA; Operating: 18 mA.
<b>Mounting Height:</b> OSC-200: 7.9 to 13.8' (2.4 to 4.2 m); OSW-100: 5.9 to 11.8' (1.8 to 3.6 m).
<b>Power Requirements:</b> 22-26 VAC/DC.
<b>Weight:</b> OSC-200: 2.4 oz (68 g); OSW-100: 3.2 oz (90.7 g).
<b>Agency Approvals:</b> CE.

**SELECTION GUIDE**  
pages 236-241

**TYPICAL APPLICATIONS**  
pages 242-244

**TECHNICAL INFORMATION**  
page 245

**Flowmeters, Variable Area & In-Line**  
pages 246-259, 266

**Flowmeters, Dial**  
page 260

**Flowmeters, Venturi**  
page 261

**Flow Sensors, In-Line**  
pages 262-263

**Flowmeters, Orifice Plate**  
pages 264-265

**Sight Flow Indicators**  
pages 267-269

**Flow Switches, Paddle**  
pages 270-275

**Flow Switches, Thermal**  
page 276

**Flow Switches, Shuttle/Piston**  
pages 277-279

**Flow Transmitters, In-Line**  
page 280

**Flow Transmitters, Paddlewheel, Adjustable Insertion**  
page 281

**Flow Transmitters, Paddlewheel, In-Line**  
pages 282-284

**Water Meters**  
pages 285-287

**Flow Transmitters, Ultrasonic**  
pages 288-289, 295

**Flow Transmitters, Ultrasonic, Portable**  
page 290

**Flow Transmitters, Electromagnetic, In-Line**  
page 291

**Flow Transmitters, Electromagnetic, Thermal Energy Meter**  
pages 292-293

**Flow Transmitters, Electromagnetic, Remote Display**  
page 293

**Flow Transmitters, Electromagnetic, Adjustable Insertion**  
page 294

**Mass Flowmeters/Controllers**  
pages 296-298

## FEATURED PRODUCTS

### INSERTION THERMAL ENERGY METER SERIES IEFB | pages 292-293



- Field configurable
- Integral or remote display for ultimate flexibility
- Complies with high accuracy requirements of EN 1434-1, ASTM E3137, CSA C900.1-13 for accurate heat measurement

### INSERTION ELECTROMAGNETIC FLOW TRANSMITTER SERIES IEF | page 294









- Field configurable
- Integral or remote displays allow for ultimate flexibility
- Multiple display configurations with a single unit



## GENERAL PURPOSE PANEL MOUNT

## Flowmeters

						
<b>SERIES</b>	<b>RMA</b> - pages 246-247	<b>RMB</b> - pages 246-247	<b>RMC</b> - pages 246-247	<b>VFA</b> - pages 248	<b>VFB</b> - pages 248	<b>VFC</b> - page 248
<b>Ranges</b>	0.05 to 200 SCFH air (5 to 2500 cc/m air); 1 to 50 GPH water (5 to 300 cc/m water)	0.5 to 600 SCFH air (0.6 to 95 LPM air); 1 to 100 GPH water (0.06 to 6.2 LPM water)	5 to 1800 SCFH air (2.5 to 850 LPM air); 0.1 to 10 GPM water (0.05 to 5 LPM water)	0.1 to 200 SCFH air (0.06 to 100 LPM air); 0.6 to 40 GPH water (6 to 200 cc/m water)	0.3 to 200 SCFH air (0.2 to 40 LPM air); 0.5 GPH to 5 GPM water (0.002 to 20 LPM water)	2.5 to 100 SCFM air (60 to 2800 LPM air); 0.5 to 20 GPM water (2 to 75 LPM water)
<b>Accuracy</b>	±4% FS	±3% FS	±2% FS	±5% FS	±3% FS	±2% FS
<b>Body Materials</b>	Polycarbonate	Polycarbonate	Polycarbonate	Acrylic	Acrylic	Acrylic
<b>Temperature Limits</b>	130°F (54°C)	130°F (54°C)	130°F (54°C)	With valve: 120°F (48°C); Without valve: 100°F (38.6°C)	With valve: 120°F (48°C); Without valve: 100°F (38°C)	120°F (48°C)
<b>Pressure Limits</b>	100 psi (6.7 bar)	100 psi (6.7 bar)	100 psi (6.7 bar)	With valve: 100 psi (6.7 bar); Without valve: 150 psi (10 bar)	With valve: 100 psi (6.7 bar); Without valve: 150 psi (10 bar)	100 psi (6.7 bar)
<b>Process Connection</b>	1/8" female NPT back connections	1/4" female NPT back connections	1/2" female NPT back connections	1/8" female NPT back or end connections	1/8" female NPT back or end connections	1" female or male NPT or BSPT back or end connections
<b>Scale Length</b>	2" (51 mm)	5" (127 mm)	10" (254 mm)	2" (51 mm)	4" (102 mm)	5" (127 mm)
<b>Metering Valve</b>	Optional bottom or top mount brass or stainless steel valve	Optional bottom brass or stainless steel valve	Optional bottom brass or stainless steel valve	Optional bottom or top mount brass or stainless steel valve	Optional bottom brass or stainless steel valve	N/A

## CORROSIVE MEDIA







## Flowmeters

								
<b>SERIES</b>	<b>VAT</b> - page 254	<b>TVA</b> - page 254	<b>VA1000</b> - page 255	<b>VA1500</b> - page 255	<b>VAT20000</b> - page 255	<b>VA25000</b> - page 255	<b>DR10000</b> - page 256	<b>DR20000</b> - page 256
<b>Ranges</b>	1.19 to 79 GPH water (75 to 5000 ml/min water)	6.34 to 79.2 GPH water (400 to 5000 ml/min water)	0.104 to 89.2 SCFH air (49 to 42000 ml/m air) 0.009 to 19.97 GPH water (0.55 to 1260 ml/m water)	0.22 to 49 SCFH air (104 to 23100 ml/min air) 0.028 to 27 GPH water (1.8 to 522 ml/min water)	0.792 to 93.9 SCFH air (374 to 44300 ml/min air) 0.087 to 21.7 GPH water (5.5 to 1370 ml/m water)	0.104 to 18.39 SCFH air (49 to 8600 ml/m air) 0.01 to 3.32 GPH water (0.61 to 209 ml/min water)	0.24 to 100 SCFH air (0.13 to 50 LPM air) 0.02 to 24 GPH water (1.5 to 1500 cc/m water)	0.33 to 90 SCFH air (0.16 to 44 LPM air) 0.05 to 21 GPH water (3.2 to 1300 cc/m water)
<b>Accuracy</b>	±5% FS	±5% FS	±2% FS	±2% FS	±2% FS	±2% FS	±5% FS	±5% FS
<b>Body Materials</b>	PFA	PFA	Glass flow tube	Glass flow tube	Glass flow tube	Glass flow tube	Glass flow tube	Glass flow tube
<b>Temperature Limits</b>	250°F (121°C)	250°F (121°C)	250°F (121°C)	150°F (65°C)	250°F (121°C)	150°F (65°C)	250°F (121°C)	250°F (121°C)
<b>Pressure Limits</b>	100 psi (6.7 bar)	100 psi (6.7 bar)	200 psi (13.8 bar)	100 psi (6.7 bar)	200 psi (13.8 bar)	100 psi (6.7 bar)	250 psi (17 bar)	250 psi (17 bar)
<b>Process Connection</b>	1/4" or 3/8" female NPT back connections	1/4" or 3/8" female NPT back connections	1/8" female NPT back connections	1/8" female NPT back connections	1/8" female NPT back connections	1/8" female NPT back connections	1/8" female NPT back connections	1/8" female NPT back connections
<b>Scale Length</b>	5" (127 mm)	3" (75 mm)	2.5" (65 mm)	2.5" (65 mm)	6" (150 mm)	6" (150 mm)	2.5" (65 mm)	6" (150 mm)
<b>Metering Valve</b>	N/A	Optional 6-turn needle valve	6-turn needle valve; Optional 16-turn high precision valve	6-turn needle valve	6-turn needle valve; Optional 16-turn high precision valve	6-turn needle valve	Optional 6-turn needle valve	Optional 6-turn needle valve



These Selection Guides are for quick comparison of similar products. Please refer to the catalog page number referenced for complete product information and specifications.



# GENERAL PURPOSE IN-LINE Flowmeters

						
<b>SERIES</b>	<b>LFMA</b> - page 253	<b>LFMB</b> - page 253	<b>LFMC</b> - page 253	<b>LFMD</b> - page 253	<b>LFME</b> - page 253	<b>LFMF</b> - page 253
<b>Ranges</b>	0.1 to 5 GPM water (0.5 to 18 LPM water)	0.1 to 5 GPM water (0.5 to 18 LPM water)	0.25 to 8 GPM water (1 to 30 LPM water)	0.8 to 10 GPM water (3 to 40 LPM water)	1.2 to 25 GPM water (5 to 100 LPM water)	2.5 to 70 GPM water (10 to 250 LPM water)
<b>Accuracy</b>	±5% FS	±5% FS	±5% FS	±5% FS	±5% FS	±5% FS
<b>Body Materials</b>	Polycarbonate	Polycarbonate	Polycarbonate	Polycarbonate	Polycarbonate	Polycarbonate
<b>Process Connection</b>	1/2" male NPT in-line or 90° elbow connections	1/2" male NPT in-line or 90° elbow connections	1/2" or 3/4" male NPT in-line or 1/2" male NPT 90° elbow connections	3/4" male or female NPT in-line or 3/4" male NPT 90° elbow connections	1" male or female NPT in-line or 1" male NPT 90° elbow connections	2" male or female NPT in-line connections
<b>Scale Length</b>	2" (51 mm)	3" (76 mm)	3" (76 mm)	3.5" (89 mm)	4.5" (114 mm)	5.5" (140 mm)

# INDUSTRIAL Flowmeters

		
<b>SERIES</b>	<b>IF</b> - page 257	<b>HF</b> - page 259
<b>Ranges</b>	1.2 to 250 SCFM air (35 to 7080 LPM air); 0.25 to 116 GPM water (0.95 to 439 LPM water)	2 to 22 SCFM air; 0.5 to 25 GPM oil; 0.05 to 116 GPM water
<b>Accuracy</b>	±3% FS	±4% FS
<b>Body Materials</b>	Glass flow tube	Aluminum, brass, or 304 SS
<b>Temperature Limits</b>	200°F (93°C)	240°F or 400°F (115° or 204°C)
<b>Pressure Limits</b>	200 psi (13.8 bar); some models 125 psi (8.6 bar)	600 psi to 6000 psi (41 to 413 bar)
<b>Process Connection</b>	1/2", 1" or 2" female NPT back connections	1/8" to 2" female NPT back connections
<b>Scale Length</b>	4-3/4" (120 mm)	1-1/2" to 2-1/4" (38 to 57 mm)

These Selection Guides are for quick comparison of similar products. Please refer to the catalog page number referenced for complete product information and specifications.



## PADDLE AND THERMAL STYLE Flow Switches

							
<b>SERIES</b>	<b>V4</b> - pages 270-271	<b>V6</b> - pages 272-273	<b>V7</b> - page 274	<b>V10</b> - page 274	<b>V8</b> - page 275	<b>FS-2</b> - page 276	<b>TDFS2</b> - page 276
<b>Service</b>	Gases or liquids	Gases or liquids	Liquids	Gases or Liquids	Liquids	Liquids	Liquids
<b>Set Point Range</b>	3 to 2400 GPM (12 to 9000 LPM); 17 to 10000 SCFM (8 to 4700 LPM)	.03 to 10 GPM (.11 to 38 LPM); .15 to 43 SCFM (4 to 1200 LPM)	7.5 to 58.0 GPM (28.4 to 218 LPM)	2.3 to 9.5 GPM (8.7 to 36 LPM); 8.8 to 50 SCFM (250 to 1420 LPM)	6.8 to 58 GPM (25.7 to 218 LPM)	4 to 396 GPM (15 to 1500 LPM)	0.5 to 10 ft/s (0.15 to 3 m/s)
<b>Wetted Materials</b>	Brass, 430 SS, 316 SS*	Brass or 303 SS, 301 SS, 302 SS, Ceramic*	301 SS	Brass or 303 SS, 316 SS, 301 SS, 302 SS, Ceramic	Brass or 316 SS, 301 SS, 302 SS, Ceramic	Tin-Bronze, Brass, SS	316 SS
<b>Temperature Limits</b>	-4 to 400°F (-20 to 205°C)	-4 to 400°F (-20 to 205°C)	250°F (121°C)	200°F (93°C)	-40 to 250°F (-40 to 121°C)	230°F (110°C)	140°F (60°C)
<b>Pressure Limits</b>	5000 psig (345 bar)	2000 psig (138 bar)	2000 psig (138 bar)	2000 psig (138 bar)	250 psig (17.2 bar)	145 psig (10.0 bar)	300 psig (20.67 bar)
<b>Adjustable Set Point</b>	Yes	Yes	Yes	Yes	Yes	Yes	Yes
<b>Power Requirement</b>	None	None	None	None	None	None	9-24 VDC
<b>Enclosure Rating</b>	WP and EXP	WP and EXP	WP	WP	WP	WP	NEMA 4X (IP65)
<b>Switch Type</b>	SPDT or DPDT	SPDT or DPDT	SPDT	SPST	SPDT	SPDT	1 NO NPN, 1 NC NPN
<b>Process Connection</b>	1-1/2" male NPT* or 1-1/2" male BSPT	1/2" male NPT* or 1/2" male BSPT	1" male NPT	1/2" male NPT* or 1/2" male BSPT	1" male NPT	1" male NPT or BSPT	1" male NPT
<b>Agency Approvals</b>	ATEX, CE, CSA, FM, IECEx, UL**	ATEX, CE, CSA, IECEx, KTL, UL	CE, UL	CE, CSA, UR	CE, cURus	CE	CE

\*Other options available, contact factory

\*\*No housing option (-NH) has no approvals





## PADDLE WHEEL/TURBINE/MULTI-JET Flow Transmitters

			
<b>SERIES</b>	<b>PFT</b> - page 281	<b>SFI-100T</b> - page 283	<b>DFMT</b> - page 284
<b>Service</b>	Liquids	Liquids	Liquids
<b>Wetted Materials</b>	Brass or 316 SS	Brass	PVDF
<b>Accuracy</b>	±1% FS	±5% FS	±1.5% FS
<b>Temperature Limits</b>	212°F (100°C)	-20 to 212°F (-29 to 93°C)	194°F (90°C)
<b>Pressure Limits</b>	400 psig (27.6 bar)	125 psig (8.6 bar)	145 psi (1.0 mPa)
<b>Pipe Size</b>	1-1/2 to 40" (38.1 to 1016 mm)	1/2" or 3/4" (12.7 mm or 19 mm)	3/8", 1/2", 3/4", 1", 1-1/2" or 2" (9.5 mm, 12.7 mm, 19 mm, 25.4 mm, 38 mm or 50.8 mm)
<b>Flow Rate</b>	1.2 to 25 ft/s (0.37 to 7.62 m/s)	2 to 35 GPM (7.6 to 132.5 LPM)	0.44 to 176.11 GPM (0.1 to 40 m³/h)
<b>Output</b>	4-20 mA or pulsed	Pulsed	4-20 mA or pulsed

These Selection Guides are for quick comparison of similar products. Please refer to the catalog page number referenced for complete product information and specifications.

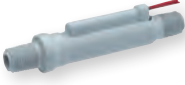
# PISTON STYLE

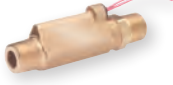

## Flow Switches

						
<b>SERIES</b>	<b>P2</b> - page 277	<b>P3</b> - page 277	<b>P1</b> - page 278	<b>P8</b> - page 278	<b>GVS</b> - page 279	<b>AFS</b> - page 279
<b>Service</b>	Gases or liquids	Liquids	Liquids	Liquids	Liquids	Gases or Liquids
<b>Set Point Range</b>	.05 to 1 GPM (.2 to 3.79 LPM); .42 to 5 CFM (11.9 to 141 LPM)	.25 to 2 GPM (.95 to 7.57 LPM)	.1 to 1.5 GPM (.38 to 5.7 LPM)	.25 to 2 GPM (.95 to 7.57 LPM)	1 to 8 GPM (3.8 to 30.3 LPM)	1 to 75 SCFM @ 5 psi (28 to 2123 LPM @ 5 psi); .5 to 20 GPM (2 to 75.5 LPM)
<b>Wetted Materials</b>	PPE & PS, Epoxy, 316 SS	Polypropylene, PPS Composite, 316 SS, Fluorocarbon	Brass, Polysulfone, 316 SS, Fluoroelastomer, Epoxy	Brass, PPS Composite, Epoxy, 316 SS, Fluorocarbon	Bronze, TFE, 316 SS, Fluoroelastomer, Ceramic	316 SS, Fluoroelastomer, Epoxy, Brass
<b>Temperature Limits</b>	0 to 212°F (-18 to 100°C)	0 to 212°F (-18 to 100°C)	-20 to 225°F (-29 to 107°C)	-20 to 275°F (-28 to 135°C)	-20 to 200°F (-29 to 93°C)	-20 to 300°F (-29 to 149°C)*
<b>Pressure Limits</b>	150 psig (10.3 bar) @ 70°F (21°C); 50 psig (3.4 bar) @ 212°F (100°C)	125 psig (8.6 bar) @ 70°F (21°C); 50 psig (3.4 bar) @ 212°F (100°C)	1000 psig (69 bar)	1500 psig (103 bar)	400 psig (27 bar) @ 100°F (38°C)	1000 psig (69 bar)
<b>Adjustable Set Point</b>	No	No	No	No	Yes	Yes
<b>Power Requirement</b>	None	None	None	None	None	None
<b>Enclosure Rating</b>	GP	GP	GP	GP	GP	GP
<b>Switch Type</b>	SPST, NO	SPST, NO	SPDT	SPST, NO	SPDT	SPDT
<b>Process Connection</b>	1/4" male NPT	3/8" male NPT or 1/4" Quick Disconnect	1/4" female NPT	3/8" male NPT	1" female NPT	1/2" female NPT
<b>Agency Approvals</b>	CE	CE	CE	CE	CE	CE

\*Other options available, contact factory

# FLOW

## Water Meters

			
<b>SERIES</b>	<b>WMH</b> - page 285	<b>WMT2</b> - page 286	<b>WPT</b> - page 287
<b>Service</b>	Water	Water	Water
<b>Wetted Materials</b>	Body and couplings: Brass; Measuring chamber: ABS plastic	Body and couplings: Brass; Measuring Chamber: ABS plastic	Body: Nylon 66; Couplings: Nylon 66, 1-1/2" (40 mm) sizes lead free ECO BRASS®; Measuring chamber: ABS plastic
<b>Accuracy</b>	WMH-A-X-XX: Transitional flow: ±3%; Nominal flow: ±1.5%	±2% FS	WPT-A-X-XX: Transitional flow: ±3; Nominal flow: ±1.5%
<b>Temperature Limits</b>	190°F (88°C)	104°F (40°C)	122°F (50°C)
<b>Pressure Limits</b>	150 psi (10 bar)	232 psi (16 bar)	150 psi (10 bar)
<b>Pipe Size</b>	5/8" x 1/2" to 2" (15 mm to 50 mm)	1/2" to 2" (12.7 mm to 50 mm)	5/8" x 1/2" to 1-1/2" (15 mm to 40 mm)
<b>Flow Rate</b>	20 to 160 GPM (3 to 30 m³/h)	20 to 160 GPM (3 to 30 m³/h)	20 to 160 GPM (3 to 30 m³/h)
<b>Output</b>	Pulsed	Pulsed	Pulsed

ECO BRASS® is a registered trademark patent by Mitsubishi Shindoh

These Selection Guides are for quick comparison of similar products. Please refer to the catalog page number referenced for complete product information and specifications.



## ULTRASONIC Flow Transmitters



SERIES	UFM - page 289	PUB - page 290
Service	Liquids	Liquids
Wetted Materials	N/A	N/A
Accuracy	±3% of reading	±2% FS
Temperature Limits	185°F (85°C)	275°F (135°C)
Pipe Size	0.98 to 4.62" (24.89 to 117.35 mm)	0.5 to 78" (13 to 2000 mm)
Flow Rate	0.33 to 32.8 ft/s (0.1 to 10 m/s)	0.33 to 65.62 ft/s (0.1 to 20 m/s)
Output	4-20 mA and pulsed	4-20 mA, 0-16 mA or 0-20 mA and pulsed
Enclosure Rating	NEMA 4X (IP66)	NEMA 4X (IP66)

## FLOW Heat Meters



SERIES	IEFB - pages 292-293	TUF - page 295
Services	Compatible clean or dirty non coating, conductive liquids	Clean, compatible liquids
Wetted Materials	316 SS, polystyrene and Silicon	Brass and 316L SS
Range	0 to 20 ft/s (0 to 6 m/s)	Refer to flow rate below
Accuracy	BTU: RTD and calculator meet EN1434 Class B; Flow: 1% of reading or 1% FS (model dependant)	BTU: EN1434/CJ128 CLASS 2; Flow: ±(2+(0.02 Qp/Q))
Temperature Limits	32 to 250°F (0 to 121°C)	36 to 203°F (2 to 95°C)
Pressure Limits	400 psi (27.6 bar)	362 psi (25 bar) (model dependant)
Pipe Size	4 to 36" (101 to 914 mm) (model dependant)	1/2 to 8" (15 to 200 mm)
Flow Rate	Refer to velocity range above	0.1 to 881 GPM (0.5 to 3333 LPM)
Output	(1) Analog (1) Pulse/frequency (1) Empty Pipe detection/ min. or max velocity trigger (1) Reverse flow pulse output indication (1) BACnet or Modbus®	BACnet, Modbus® or M-BUS (model selectable)

Modbus® is a registered trademark of Schneider Automation, Inc.

These Selection Guides are for quick comparison of similar products. Please refer to the catalog page number referenced for complete product information and specifications.



# ELECTROMAGNETIC, IN-LINE/INSERTION Flow Transmitters



**SERIES**

**UFB** - page 288

**MFS** - page 291

**IEF** - page 294

<b>Service</b>	Liquids	Liquids	Liquids
<b>Wetted Materials</b>	N/A	316 SS	316 SS
<b>Accuracy</b>	±2% of reading	±2% of reading	0.5% of reading, 1% of reading or ±1% FS
<b>Temperature Limits</b>	275°F (136°C)	194°F (90°C)	15 to 250°F (-9 to 121°C)
<b>Pressure Limits</b>	N/A	232 psi (16 bar)	400 psi (27.6 bar)
<b>Pipe Size</b>	0.05 to 79" (13 to 2000 mm)	1/2 or 1" (12.7 or 25 mm)	4 to 36" (101 to 914 mm)
<b>Flow Rate</b>	0.33 to 33 ft/s (0.1 to 10 m/s)	0.25 to 52.8 GPM (1 to 200 LPM)	0 to 20 ft/s (0 to 6 m/s)
<b>Output</b>	4-20 mA, 0-16 mA or 0-20 mA	4-20 mA or pulsed	(1) Analog: 4-20 mA, 0-5 V, 0-10 V or 2-10 V (display selectable); (1) Pulse/Frequency: 0-15 V peak pulse, 0-500 Hz or scalable pulse output (display selectable); (2) Alarm: (1) Empty pipe detection or minimum/maximum velocity, (display selectable); (1) Reverse flow output indication

ECO BRASS® is a registered trademark patent by Mitsubishi Shindoh  
Modbus® is a registered trademark of Schneider Automation, Inc.

These Selection Guides are for quick comparison of similar products. Please refer to the catalog page number referenced for complete product information and specifications.



**Designers of a bio-medical incubator rely on a Dwyer® flowmeter to control CO<sub>2</sub> flow.**

This low temperature incubator with CO<sub>2</sub> atmosphere is used in bio-medical applications, such as short term blood work and long term tissue culture studies. CO<sub>2</sub> is introduced at a high initial purge rate controlled by a timer. After the purge period, a Dwyer® Visi-Float® flowmeter with a metering valve is utilized to adjust and monitor the CO<sub>2</sub> flow in cubic centimeters per minute. The Visi-Float® flowmeter provides the reliability and accuracy needed to complement the host of high performance features designed into this incubator.

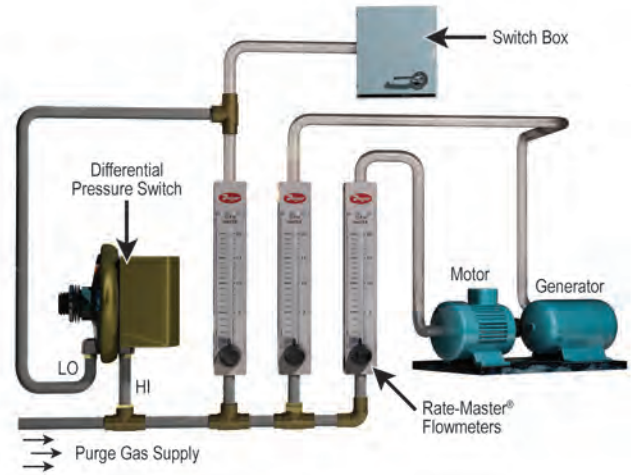

**Flowmeters and/or differential pressure switches monitor vital purge gas flow to motors, switchgear, instruments.**

To purge motors, generators, switchgear, and industrial instrument cases, Dwyer® flowmeters are installed in the supply line to indicate a flow of air, manufactured inert gas, or nitrogen to these devices. The flowmeters (with valves) allow maintenance personnel to set the flow quickly and recheck anytime to make sure proper flow continues. A Dwyer® differential pressure switch can also be used to monitor proper flow on a continuous basis and provide a signal or alarm if purge gas flow fails. Such an optional switch is shown above, monitoring proper flow of purge gas to the switchbox as a function of pressure drop across the flowmeter. The purging of electrical equipment in hazardous areas may require more extensive control and monitoring devices.

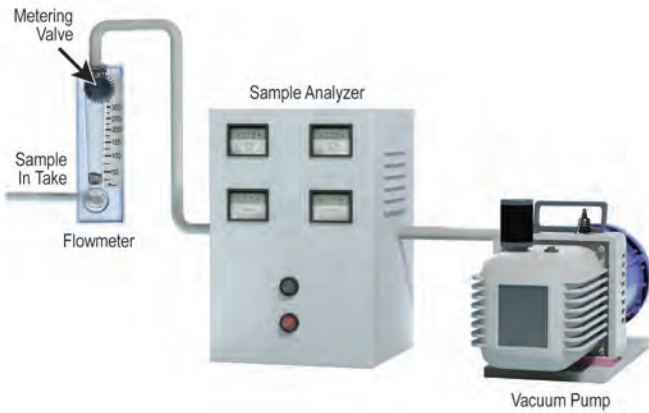

**Metering valves on Dwyer® flowmeters control air/gas intake on permanent air pollution analyzers.**

Regulations regarding air pollution levels require continuous monitoring a source and ambient pollutants in areas where noxious gases are generated. Ambient air quality samplers utilize either Visi-Float® or Rate-Master® flowmeters to establish the proper flow of sample or carrier gases into the analyzer. Top mounted metering valves are recommended for flowmeters used in vacuum service to maintain specified accuracy.

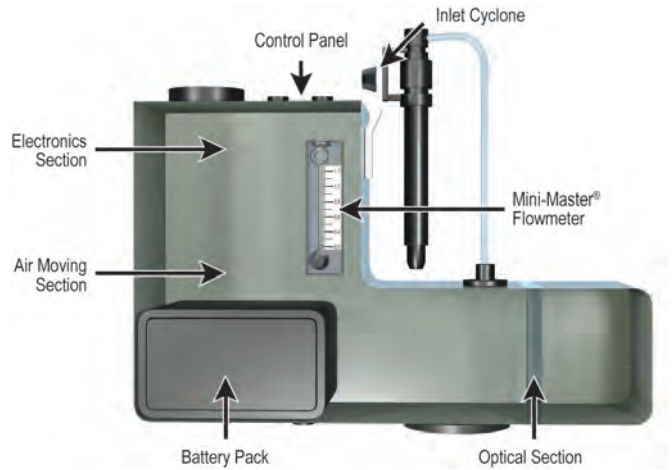

**Operator uses Mini-Master® flowmeter to verify air flow into portable dust monitor.**

The small size, accuracy, and low cost of the Dwyer® Mini-Master® Series flowmeter lends itself perfectly to use in this portable, battery-operated dust monitor. Using a light scattering electronic sampler, a small vacuum pump draws air through the flowmeter into the sampling chamber, and the flowmeter verifies the proper volume of sample air flow. Readout is digital and directly in dust weight per cubic meter of air.

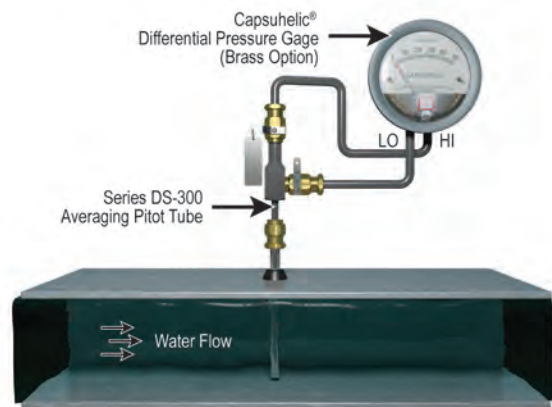

### Brass body gage measures water flow rates.

A Dwyer® brass body Capsuhelic® differential pressure gage, required for water service to prevent corrosion damage to the gage, is used in conjunction with a Dwyer® Series DS-300 averaging Pitot tube. The Capsuhelic® gage provides a basic method of measuring water flow rates. As a guide in selecting the appropriate Capsuhelic® gage range, the designer can consult data provided with the DS-300 averaging Pitot tube. This relates differential pressure in inches of water column to the water flow in gallons per minute for the pipe size involved. The gage can be calibrated directly in GPM if desired. Bleed fittings installed in the top ports of the gage are recommended to facilitate removal of air from the system.

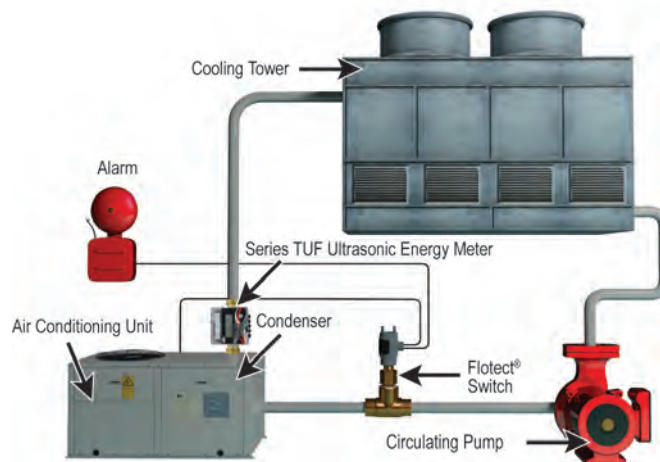

### Flotect® flow switch ensures cooling water circulation before air conditioning compressor motor starts and Series TUF monitors thermal energy loss from cooling tower to air condenser.

Large air conditioning and refrigeration systems which include water cooled condensers require that the water must circulate through the condenser and cooling tower in sufficient volume before the compressor is started. Here the W.E. Anderson® Flotect® flow switch is connected to the compressor control circuit to prevent starting or to shut down the compressor control circuit if the flow of cooling water falls below that required for proper operation. A dual Flotect® switch (available as an option) will also trigger a remote alarm to signal the operator of the shutdown as soon as it occurs. The Series TUF monitors the water flow as well as the temperature of the water going into and out of the air conditioning unit in order to calculate the cooling efficiency of the air conditioning unit.

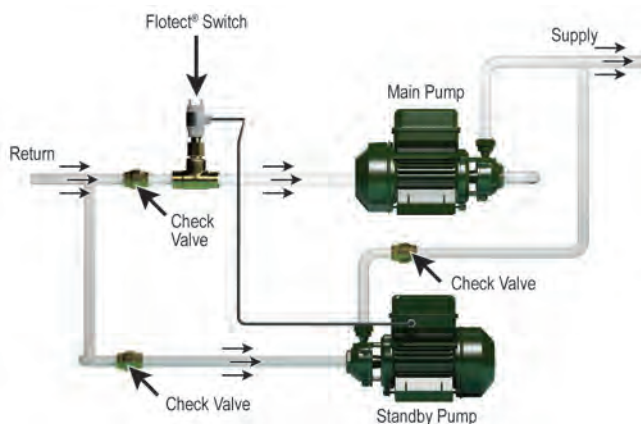

### When main pump fails, Flotect® flow switch transfers to standby pump to maintain vital fluid circulation.

When proper fluid circulation in a system is critical, the W.E. Anderson™ Flotect® flow switch will automatically start a standby pump should the main pump fail. The flow in the main path of the parallel system illustrated keeps the Flotect® flow switch in an open position. When the main pump fails, the flow will cease. The flow switch then closes, starting the standby pump.



### W.E. Anderson® Midwest Sight Flow Indicator reveals flow or stoppage.

In this gravity feed system delivering liquid fertilizer to portable tanks, a Series SFI-100 MIDWEST sight flow indicator was installed. The operator can see the rotating vanes to check for adequate flow at any time.



**Flows of air and gases used in a special furnace are controlled by Dwyer® flowmeters.**

A total of eleven Dwyer® Rate-Master® flowmeters function in the design of this sophisticated conveyor belt furnace used in manufacturing electronic devices. The flowmeters provide precise adjustment and monitoring of the flows of air and gases into the various portions of the furnace, which allow it to perform different operations, such as decarburizing and oxidizing, metallic package sealing, glass package sealing, and glass-to-metal sealing.



**Durable dual-column flowmeter adds value for physicians and oral surgeons.**

Physicians and oral surgeons who use anesthesia or analgesia in their offices on an occasional basis require a system that is reliable but small and portable. One such system employs special Dwyer® dual-column Visi-Float® flowmeters to meter and monitor precise flows of nitrous oxide and oxygen to the patient. In addition to meeting the performance level demanded by this application, the Visi-Float® flowmeters are durable and attractive complements to this important and visible medical device.



**Salt corrosion test cabinet includes a Dwyer® flowmeter for adjustment of bubbler air flow.**

Prior to atomizing a heated salt solution to produce a fog inside this corrosion test cabinet, compressed air is bubbled through a heated water column to properly heat and humidify the air. A Dwyer® Visi-Float® VFA flowmeter, as part of the system, provides precise adjustment of the bubbler air flow to meet test standards.

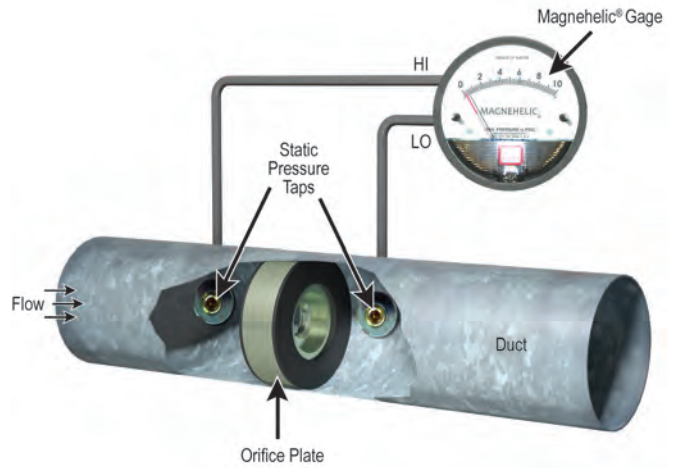

**Measuring air velocity with an orifice plate.**

In this set-up, the Magnehelic® gage measures higher air velocities as a function of the pressure drop across a sharp-edged orifice plate in the pipe. The pressure drops can be converted to air velocity using orifice plate data supplied by the manufacturer. Details regarding available sizes, ranges, installation, and limitations are available from orifice plate manufacturers and from standard handbooks. A Dwyer® Durablock® inclined manometer or Photohelic® differential pressure switch/gage can also be used. In addition to the visual reading gage, the Photohelic® switch/gage provides an alarm signal or shutdown control function. Pressure sensing taps should be located on the side or top of the pipe or duct to prevent condensation from draining into sensing lines or gages.



# CONVERSION CURVES FOR GASES

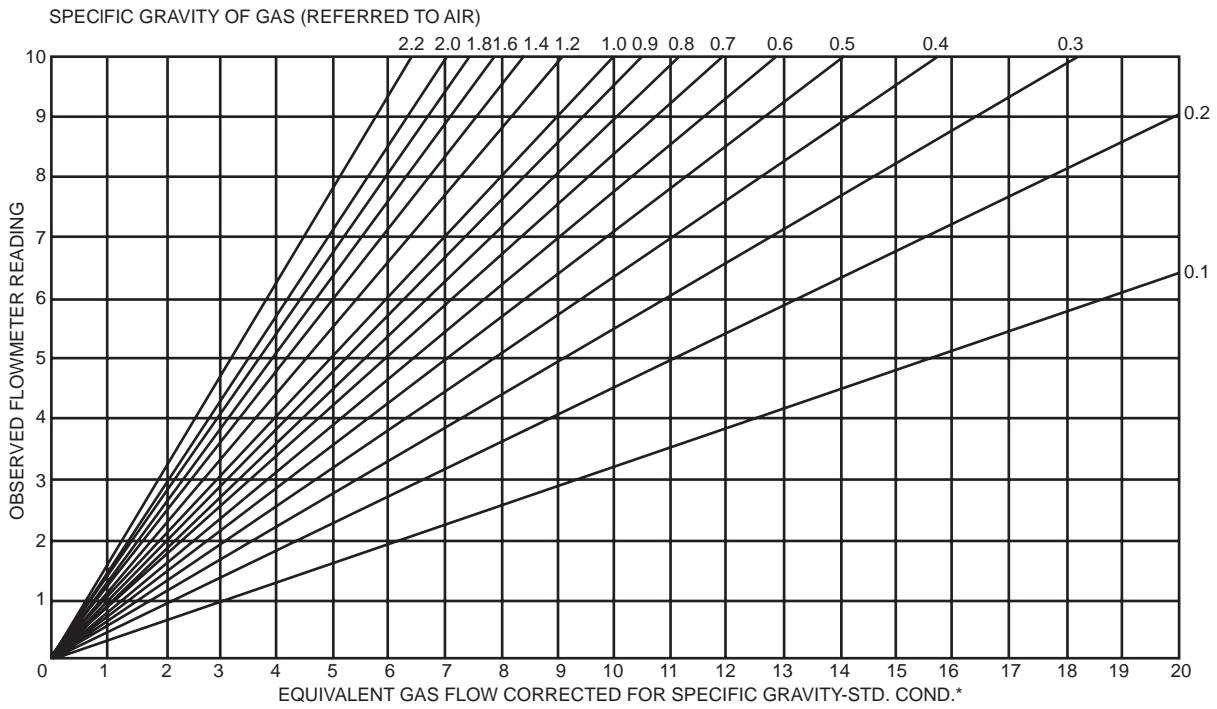
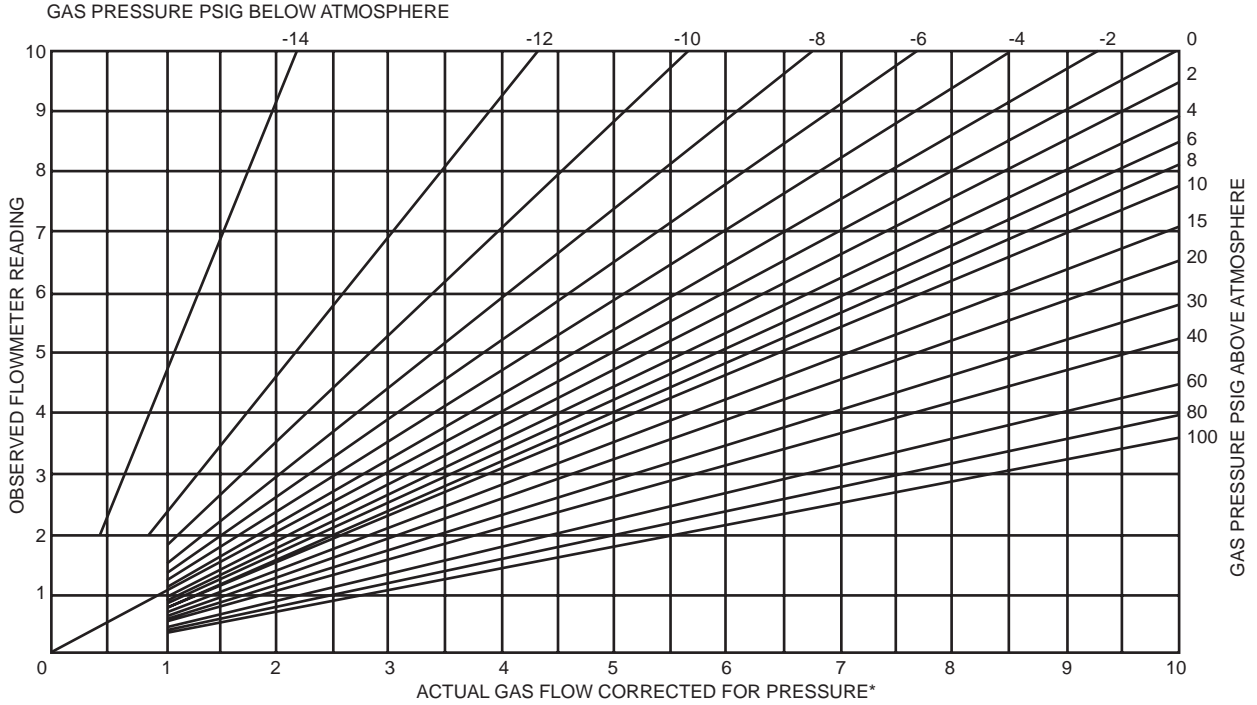

If more convenient, approximate correction factors may be determined using the following formulas:

**A. Pressure:**  $Q_2 = Q_1 \times \sqrt{\frac{P_1 \times T_2}{P_2 \times T_1}}$

Where:  $Q_1$  = Actual or observed flowmeter reading  
 $Q_2$  = Standard flow corrected for pressure and temperature  
 $P_1$  = Actual pressure (14.7 psia + gage pressure)  
 $P_2$  = Standard pressure (14.7 psia, which is 0 psig)  
 $T_1$  = Actual temperature (460 R + temp °F)  
 $T_2$  = Standard temperature (530 R, which is 70°F)

**B. Specific Gravity:**  $Q_2 = Q_1 \times \sqrt{\frac{1}{S.G.}}$

Where:  $Q_1$  = Observed flowmeter reading  
 $Q_2$  = Standard flow corrected for specific gravity  
 $1$  = Specific gravity of air or water  
 $S.G.$  = Specific gravity of media being used in flowmeter originally calibrated for air or water.

**Note:** The corrections shown in the curves and in the formulas are for variations in specific gravity and internal pressure\* only. Further correction may be necessary for variations in viscosity and changes in type of flow from laminar to turbulent or vice versa. This is particularly true in the case of extremely low flows of the lighter gases. Nevertheless these charts and correction factors can be quite useful when dealing with small changes in pressure\* and specific gravity.

\*Measured at discharge on all but TMV units. Inlet pressure on TMV models.

# RATE-MASTER® POLYCARBONATE FLOWMETERS

2", 5" or 10" Scale, Interchangeable Bodies



**Model RMC**  
10" scale, 15-3/8" high



**Model RMB-SSV**  
5" scale, 8-3/4" high



**Model RMA-TMV**  
2" scale, 4-13/16" high

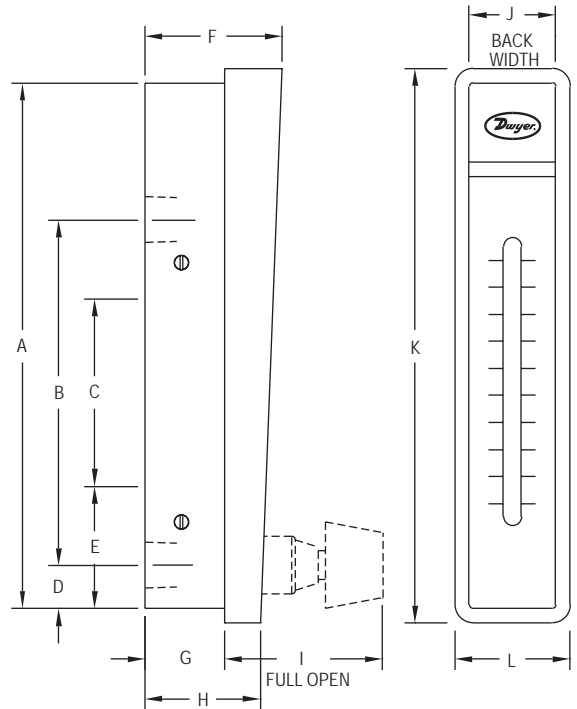

DIMENSIONS - FLOWMETER			
	Model RMA	Model RMB	Model RMC
A	4-9/16 [115.90]	8-1/2 [215.90]	15-1/8 [384.20]
B	3 [76.20] 1/8 NPT conn.	6-7/16 [163.50] 1/4 NPT conn.	12-1/4 [311.20] 1/2 NPT conn.
C	1-5/8 [41.28] 10-32 mtg. holes	3-15/16 [100.00] 1/4-20 mtg. holes	8-3/4 [222.30] 3/8-24 mtg. holes
D	3/8 [9.525]	5/8 [15.88]	1 [25.40]
E	1-1/16 [26.99]	1-7/8 [47.63]	2-3/4 [69.85]
F	1-3/16 [30.16]	1-3/4 [44.45]	2-1/2 [63.50]
G	11/16 [17.46]	1 [25.40]	1-7/16 [36.51]
H	61/64 [24.21]	1-7/16 [36.51]	1-31/32 [50.00]
I	1-3/8 [34.92]	1-13/16 [46.04]	2-1/2 [63.50]
J	3/4 [19.05]	1-1/4 [31.75]	2 [50.80]
K	4-13/16 [122.20]	8-3/4 [222.30]	15-3/8 [390.50]
L	1 [25.40]	1-1/2 [38.10]	2-1/4 [57.15]

Flowmeters,  
Variable Area & In-Line



The **Series RM Rate-Master® Polycarbonate Flowmeters** are a line of general use, direct reading precision flowmeters suitable for both gas and liquid applications. This Series consists of 2" (51 mm), 5" (127 mm) and 10" (254 mm) scales that can be panel or surface mounted with optional precision metering valves. Within a given Series, the Rate-Master® flowmeter bodies can be instantly interchanged, allowing the piping to remain undisturbed, interchangeability of the ranges, and easy cleaning.

**FEATURES/BENEFITS**

- Direct reading scales eliminate the need for troublesome conversions
- Stainless steel backbone absorbs piping torque reducing installation damage and cost
- Shatter-proof polycarbonate allows for long operation life
- Precision injection molding around a precision tapered pin enables high repeatability
- Increased reading accuracy with special integral flow guides that stabilize float movement
- Scale graduations on both side of the indicating tube allow for instantaneous flow reading saving time

**APPLICATIONS**

- Medical equipment
- Air samplers
- Gas analyzers
- Pollution monitors
- Chemical injectors
- Cabinet purging

**SPECIFICATIONS**

**Service:** Compatible gases and liquids.  
**Wetted Materials:** Body: Polycarbonate; O-ring: Neoprene and Buna-N; Metal parts: SS (except for optional brass valve); Float: SS, black glass, aluminum, K monel, tungsten carbide depending on range.  
**Temperature Limit:** 130°F (54°C).  
**Pressure Limit:** 100 psi (6.9 bar).  
**Accuracy:** RMA: 4%; RMB: 3%; RMC: 2% of FS.  
**Process Connection:** RMA: 1/8"; RMB: 1/4"; RMC: 1/2" female NPT.  
**Weight:** RMA: 4 oz (113.4 g); RMB: 13 oz (368.5 g); RMC: 39 oz (1105.6 g).  
**Agency Approvals:** Meets the technical requirements of EU Directive 2011/65/EU (RoHS II).  
**CAUTION:** Dwyer® Rate-Master® flowmeters are designed to provide satisfactory long term service when used with air, water, or other compatible media. Refer to factory for information on questionable gases or liquids. Caustic solutions, anti-freeze (ethylene glycol) and aromatic solvents should definitely not be used.

# RATE-MASTER® POLYCARBONATE FLOWMETERS

Gas Flow from 0.05 to 1800 SCFH, Water Flow to 10 GPM

RANGE CHART - RMA 2" SCALE - POPULAR RANGES			
Range No.	SCFH Air	Range No.	LPM Air
1	.05 to .4	26	.5 to 5
2	.1 to 1	21	1 to 10
3	.2 to 2	22	2 to 25
4	.5 to 5	23	5 to 50
5	1 to 10	24	5 to 70
6	2 to 20	25	10 to 100
7	5 to 50		
Range No.	CC/Min. Water		
8	10 to 100	32	5 to 50
9	15 to 150	33	10 to 110
10	20 to 200	34	20 to 300
Range No.	CC/Min. Air	Range No.	GPH Water
151*	5 to 50	42	1 to 11
150*	10 to 100	43	2 to 24
11	30 to 240	44	4 to 34
12	50 to 500	45	5 to 50
13	100 to 1000		
14	200 to 2500		

\*Accuracy ±8%

RANGE CHART - RMB 5" SCALE - POPULAR RANGES			
Range No.	SCFH Air	Range No.	SCFH & LPM Air
49*	0.5 to 5	50D	1.2 to 10/0.6 to 5
50	1 to 10	51D	2 to 20/1 to 9.5
51	3 to 20	52D	4 to 50/2 to 23
52	4 to 50	53D	10 to 100/5 to 50
53	10 to 100	54D	20 to 200/10 to 95
54	20 to 200		
Range No.	GPH & LPM Water		
55	40 to 400	82D	1 to 12/0.06 to 0.76
56	50 to 500	83D	1 to 20/0.065 to 1.25
57	60 to 600	85D	10 to 100/0.8 to 6.2
Range No.	GPH Water		
82	1 to 12		
83	1 to 20		
84	4 to 40		
85	10 to 100		

\*Accuracy ±5%

RANGE CHART - RMC 10" SCALE - POPULAR RANGES			
Range No.	SCFH Air	Range No.	GPH Water
101	5 to 50	134	2 to 20
102	10 to 100	135	8 to 90
103	20 to 200		
Range No.	GPM Water		
104	40 to 400	141	.1 to 1
105	60 to 600	142	.2 to 2.2
106	100 to 1000	143	.4 to 4
107	120 to 1200	144	.8 to 7
108	200 to 1800	145	1.2 to 10
Range No.	SCFM Air		
121	1 to 10		
122	2 to 20		
123	4 to 30		

MODEL CHART	
Model	Description
RMA-X	Standard RMA
RMA-X-BV+	RMA with brass valve
RMA-X-SSV+	RMA with stainless steel valve
RMA-X-TMV*+	RMA with top mounted valve
RMB-X	Standard RMB
RMB-X-BV+	RMB with brass valve
RMB-X-SSV+	RMB with stainless steel valve
RMC-X	Standard RMC
RMC-X-BV+	RMC with brass valve
RMC-X-SSV+	RMC with stainless steel valve

**How To Order:** Series-Range No. ("X")-Valve-Option  
**Example:** RMA-2-SSV  
 (Series RMA with .1-1 SCFH air range & stainless steel valve)

\*Provide same precision construction but for vacuum applications.  
 +Valve is designed for flow adjustment only, not intended to be used as an open/shut-off valve.

OPTIONS	
To order add suffix:	Description
-NIST	NIST traceable calibration certificate
-APF	Adjustable pointer flag for Series RMA
-BPF	Adjustable pointer flag for Series RMB
-CPF	Adjustable pointer flag for Series RMC

**Note:** Special ranges, scales, mounting arrangements, etc., are available on special order, or in OEM quantities.



**Adjustable pointer flags**

Red lined pointer flags provide quick visual reference to a required flow level. Of clear plastic, they snap into place inside bezel and slide to desired level.

ACCESSORIES	
Model	Description
RKA	Regulator kit for Series RMA
RK-RMB	Regulator kit for Series RMB



**Regulator kits**

Available as optional extras for both Rate-Master® Flowmeters and Visi-Float® Flowmeters models. This view shows Model VFA Visi-Float® flowmeter with integrally connected constant differential pressure regulator. Recommended for use where inlet air pressure fluctuates widely and constant flow is required. The regulator maintains a constant pressure differential of approximately 3 ±.15 psig. Supply pressure must be at least 3 psig above the flowmeter discharge to operate. The standard regulator may be used with any Dwyer Series RM or VF flowmeter up to 200 scfh. For higher flow rates consult the factory.

# VISI-FLOAT® ACRYLIC FLOWMETERS

## Hot-Stamped Scales, Multi-Angle Views of Flow

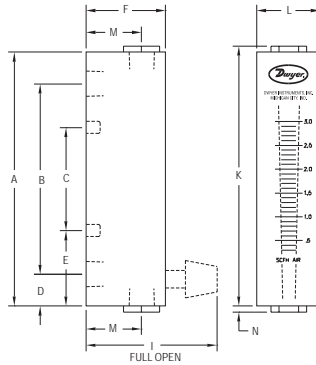

DIMENSIONS - FLOWMETER		
	Model VFA	Model VFB
A	4 [101.6]	6-1/2 [165.1]
B	3 [76.20]; 1/8 NPT conn.	5-1/2 [139.7]; 1/8 NPT conn.
C	1-5/8 [41.28]; 10-32 thd	3-1/2 [88.90]; 10-32 thd
D	1/2 [12.70]	1/2 [12.70]
E	1-3/16 [30.16]	1-1/2 [38.10]
F	1-1/4 [31.75]	1-1/4 [31.75]
I	2-1/16 [52.39]; Open	2-1/16 [52.39]; Open
K	4-3/32 [104.0]	6-11/16 [169.9]
L	1 [25.40]	1-3/8 [34.93]
M	7/8 [22.23]; 1/8 NPT	7/8 [22.23]; 1/8 NPT
N	3/32 [2.381]	3/32 [2.381]

The **Series VF Visi-Float® Acrylic Flowmeters** are a line of direct reading, precision machined, clear acrylic body flowmeters suitable for both gas and liquid applications. The fabrication of the Visi-Float® Flowmeters is backed by over 60 years of experience in acrylic instrument machining. This Series consists of 2" (51 mm) and 4" (102 mm) scales with optional precision metering valves.

**FEATURES/BENEFITS**

- Bodies are cut and precision machined from solid, clear acrylic blocks allowing for complete visual inspection
- White background allows for better visibility of the float increasing reading accuracy
- Direct reading scales are hot stamped into the plastic eliminating the need for troublesome conversions and increasing product operating life
- Precision machined tapered bore enables high repeatability
- Low installation costs with back or end connection options with metal mounting inserts that can be supported directly by system piping

**APPLICATIONS**

- Medical equipment
- Laboratory equipment
- Air samplers
- Gas analyzers
- Pollution monitors
- Chemical injectors
- Cabinet purging

**MODEL CHART**

Model	Description
VFA-X	Standard VFA
VFA-X-SS	VFA with stainless metal wetted parts
VFA-X-BV+	VFA with brass valve
VFA-X-SSV+	VFA with stainless steel valve
VFA-X-EC	VFA with end connections
VFA-X-EC-SS	VFA with end connections and stainless steel metal wetted parts
VFB-X	Standard VFB
VFB-X-SS	VFB with stainless metal wetted parts
VFB-X-BV+	VFB with brass valve
VFB-X-SSV+	VFB with stainless steel valve
VFB-X-EC	VFB with end connections
VFB-X-EC-SS	VFB with end connections and stainless steel metal wetted parts

**How To Order:** Series—Range No. ("X")—Valve—Option  
**Example:** VFA-9-BV  
 (Series VFA with 20-200 SCFH air range & brass valve)  
 +Valve is designed for flow adjustment only, not intended to be used as an open/shut-off valve.

**OPTIONS**

To order add suffix:	Description
-NIST	NIST traceable calibration certificate
-PF	Red ABS plastic pointer flag
-VIT	Fluoroelastomer O-rings

**ACCESSORIES**

Model	Description
RKA	Regulator kit for Series VFA
RK-VFB	Regulator kit for Series VFB

**OEM specials**

Special flowmeter designs can be supplied to meet a wide range of requirements and specific applications. These include: on-off plunger and push-to-test valves, special gas or fluid calibration, special ranges, scales, name brand or other identification. Pointer flags can be furnished for instant visual reference. For specific information, please supply an outline of your requirements.

**SPECIFICATIONS**

**Service:** Compatible gases & liquids.  
**Wetted Materials:** Body: Acrylic plastic; O-ring: Buna-N (fluoroelastomer available); Metal parts: Nickel plated brass standard, SS optional; Float: SS, black glass, aluminum, K monel depending on range.  
**Temperature & Pressure Limits:** Without valve: 100 psig (6.9 bar) @ 150°F (65°C); 150 psig (10 bar) @ 100°F (38°C); With valve: 100 psig (6.9 bar) @ 120°F (48°C).  
**Accuracy:** VFA = 5% of FS; VFB = 3% of FS.  
**Process Connection:** 1/8" female NPT. VFB ranges 85 and 86 have 1/4" NPT back connections or 3/8" NPT end connections. These ranges not available with brass valves.  
**Scale Length:** VFA 2" typical length; VFB 4" typical length.  
**Mounting Orientation:** Mount in vertical position.  
**Weight:** VFA: 4.0 to 4.8 oz (.11 to .14 kg); VFB: 7.2 to 8.8 oz (.20 to .25 kg).  
**Agency Approvals:** Meets the technical requirements of EU Directive 2011/65/EU (RoHS II).

**RANGE CHART - VFA 2" SCALE - POPULAR RANGES**

Range No.	SCFH Air	Range No.	LPM Air
1	.1 to 1	21	.06 to 0.5
2	.2 to 2	22	.15 to 1
3	.6 to 5	23	.6 to 5
4	1 to 10	24	1 to 10
5	2 to 20	25	3 to 25
6	4 to 30	26	6 to 50
7	5 to 50	27	10 to 100
8	10 to 100		
9	20 to 200		
Range No.	CC/Min. Water	Range No.	GPH Water
32	6 to 50	41	.6 to 5
33	10 to 100	42	2 to 10
34	20 to 200	43	3 to 20
		44	8 to 40

**RANGE CHART - VFB 4" SCALE - POPULAR RANGES**

Range No.	SCFH Air	Range No.	LPM Air
50	.3 to 3	65	.2 to 4
91*	1 to 10	66	1 to 10
51*	2 to 20	67	1 to 20
52	4 to 40	68	3 to 30
53*	10 to 100	69	4 to 40
54*	10 to 150		
55*	20 to 200		
Range No.	CC/Min. Water	Range No.	GPH Water
		82	2 to 30
Range No.	SCFM Air	Range No.	GPM Water
90	.3 to 3	80*	.5 to 12
		83*	1 to 20
Range No.	CC/Min. Air	Range No.	GPM Water
60	100 to 1000	84	6 to 40
		81	6 to 60
Range No.	GPM Water	Range No.	GPM Water
		85	.2 to 2
		86	.6 to 5

\*For dual range models in English and Metric add "D" to end of Range No.



**Special multi-column Visi-Float® flowmeters**  
 Perfect for OEM applications, Visi-Float® Flowmeters can be custom made with up to 10 columns in a single block of acrylic plastic. Available with or without valves. Consult factory for more information.

USA: California Proposition 65  
 ⚠WARNING: Cancer and Reproductive Harm - www.P65Warnings.ca.gov



# VISI-FLOAT® ACRYLIC FLOWMETERS

5" Scale, In-Line or Back Connection Options



VFCII with 1" MNPT end connections



VFC with 1" FNPT end connections



VFC with 1" FNPT back connections

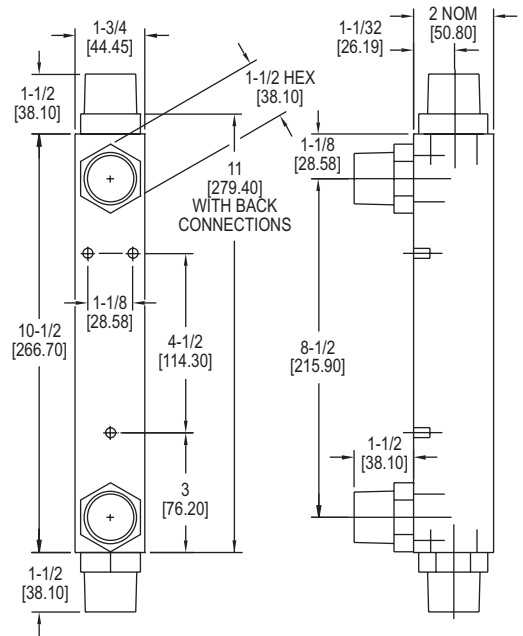

The Series VFC Visi-Float® Acrylic Flowmeters are direct reading, precision machined, clear acrylic body flowmeters suitable for both gas and liquid applications. This Series consists of two 5" (127 mm) scale flowmeters, the VFC and VFC II. The VFC features PVC 1" female NPT connections and the VFC II units are equipped with acetal thermoplastic 1" male NPT fittings.

**FEATURES/BENEFITS**

- Bodies are cut and precision machined from solid, clear acrylic blocks allowing for complete visual inspection
- White background allows for better visibility of the float increasing reading accuracy
- Direct reading scales are hot stamped into the plastic eliminating the need for troublesome conversions and increasing product operating life
- Precision machined tapered bore enables high repeatability
- Low installation costs with back or end connection options

**APPLICATIONS**

- Medical equipment
- Laboratory equipment
- Air samplers
- Gas analyzers
- Pollution monitors
- Chemical injectors
- Cabinet purging
- Remediation
- Osmosis skids

RANGE CHART - 5" SCALE - POPULAR RANGES			
Range No.	SCFM Air	Range No.	GPM Water
121	4 to 25	141	.5 to 5
122	5 to 50	142	1 to 10
123	10 to 100	143	2 to 20
Range No.	LPM Air	Range No.	LPM Water
131	100 to 700	151	2 to 20
132	200 to 1400	152	4 to 40
133	300 to 2800	153	10 to 75

**SPECIFICATIONS**

**Service:** Compatible gases & liquids.  
**Wetted Materials:** Body: Acrylic plastic; O-ring: Buna-N (fluoroelastomer available); Metal parts: SS; Float: SS.  
**Fittings:** VFC: PVC; VFCII: Acetal thermoplastic.  
**Temperature and Pressure Limits:** 100 psig (6.9 bar) @ 120°F (48°C).  
**Accuracy:** 2% of FS.  
**Process Connection:** VFC: 1" female NPT back connections. End connections optional; VFCII: 1" male NPT back connections. End connections optional.  
**Scale Length:** 5" typical length.  
**Mounting Orientation:** Mount in vertical position.  
**Weight:** 24 to 25 oz (.68 to .71 kg).  
**Agency Approvals:** Meets the technical requirements of EU Directive 2011/65/EU (RoHS II).

MODEL CHART		
Model	Thread Type	Process Connection
VFC-X	1" FNPT	Back
VFCII-X	1" MNPT	Back
VFC-X-EC	1" FNPT	In-line end
VFCII-X-EC	1" MNPT	In-line end

**How To Order:** Series-Range No.-Option  
**Example:** VFC-123-EC  
 (Series VFC with 10-100 SCFM air range and 1" female NPT end connections)

OPTIONS	
To order add suffix:	Description
-VIT	Fluoroelastomer O-rings
-FDA	316 SS float & guide rod (only available on VFCII with fluoroelastomer O-rings)
-NIST	NIST traceable calibration certificate
-BSPT	BSPT process connections

# MINI-MASTER® FLOWMETERS

2" or 1-1/2" Scale, Configurable Valve Option



Standard model  
MMA-X-LV



Standard model MMA-X  
with field configurable  
valve, bottom mount



Standard model MMA-X  
with field configurable  
valve, top mount



Model MMF-50-PV  
1-1/2" scale, with metering  
valve, knob.



Model MMF-10  
with 1-1/2" scale,  
no valve.



Model MMF-10-TMV  
with top-mounted valve-  
for vacuum service. Use  
screwdriver to adjust.

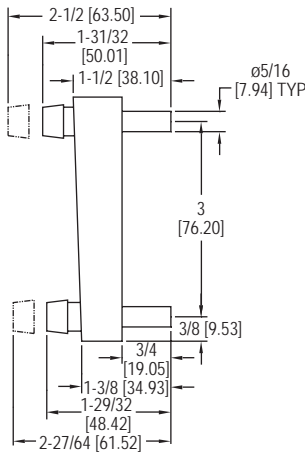
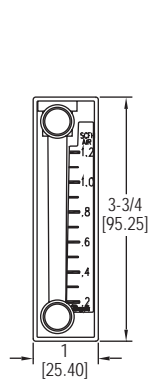

MMA-X

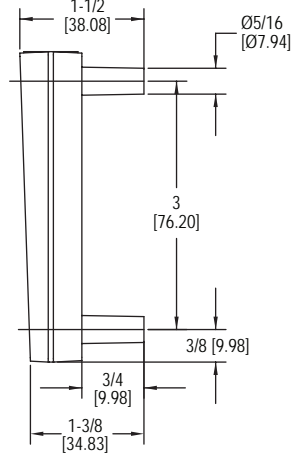
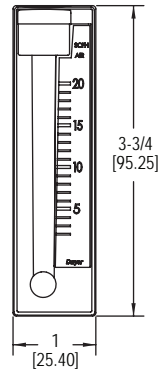

MMA-X-LV

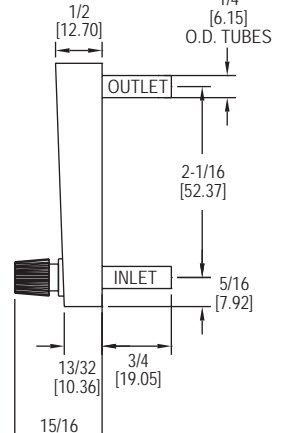
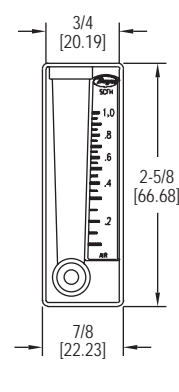

MMF-X

Flowmeters,  
Variable Area & In-Line



The **Series MM Mini-Master® Flowmeters** consists of two series of flowmeters suitable for both gas and liquid applications with advanced features at a low cost.

The Series MMA is a 2" (51 mm) scale flowmeter that is user configurable with or without non-removable top or bottom front mounted metering valves. It is constructed from transparent nylon material providing high chemical resistance and is easily disassembled via the provided key for cleaning or reconfiguration.

The Series MMF is a 1-1/2" (38 mm) scale compact flowmeter ideal for measuring small volume air. It features bezel type mounting that can be quickly installed from the front of the instrument panel.

**FEATURES/BENEFITS**

- Low installation costs with easy mounting
- Long operation life with durable construction
- Precision molding enables high repeatability
- White back on the flow tube allows for better visibility of the float increasing reading accuracy
- Side printed scale graduations allows for instantaneous flow reading saving time
- Compact bodies require minimal panel space freeing valuable space

**APPLICATIONS**

- Medical equipment
- Air samplers
- Gas analyzers
- Pollution monitors
- Chemical injectors
- Cabinet purging

**SPECIFICATIONS**

**MMA SPECIFICATIONS**

- Service:** Compatible gases and liquids.
- Wetted Materials:** Body: Nylon 12; O-rings: Buna-N (optional materials available); Float: Black glass, K monel, stainless steel, tungsten carbide.
- Temperature Limit:** 130°F (54°C).
- Pressure Limit:** 100 psi (6.9 bar) with compression fitting. 50 psi (3.4 bar) with tubing clamp.
- Accuracy:** ±4% FS.
- Process Connection:** 5/16" OD for push on rubber or plastic tubing with provided spring tubing clamp. Connect to rigid tubing with double compression fitting.
- Weight:** 1 oz (28.35 g).
- Agency Approvals:** Meets the technical requirements of EU Directive 2011/65/EU (RoHS II).

**MMF SPECIFICATIONS**

- Service:** Compatible gases and liquids.
- Wetted Materials:** Body: Styrene acrylonitrile; Float: SS, black glass, nylon; Valve: Polyurethane.
- Temperature Limit:** 125°F (51°C).
- Pressure Limit:** 50 psi (3.4 bar). Valve option: 10 psi (0.6 bar).
- Accuracy:** ±10% FS.
- Process Connection:** 1/4" OD for push on rubber or plastic tubing. Connect to rigid tubing with compression fittings.
- Weight:** 0.5 oz (14.17 g).
- Agency Approvals:** Meets the technical requirements of EU Directive 2011/65/EU (RoHS II).

# MINI-MASTER® FLOWMETERS

2" or 1-1/2" Scale, Configurable Valve Option

MODEL CHART	
Model	Description
MMA-X	Standard MMA
MMA-X-LV	MMA without configurable valve
<b>How To Order:</b> MMA-Range No.-Optional Valve	
<b>Example:</b> MMA-4-LV (Series MMA with .5-5 SCFH air range without configurable valve)	

ACCESSORIES - MMA	
Model	Description
A-327	5/16" union

RANGE CHART - MMA			
Range No.	SCFH Air	Range No.	LPM Air
3	.5 to 2.5	20	.2 to 1.2
4	.5 to 5	21	.25 to 2.5
5	1 to 10	22	.5 to 5
6	2 to 20	23	1 to 10
7	5 to 50	24	2.5 to 25
8	10 to 100	25	5 to 50
9	20 to 200	26	10 to 100
10	30 to 300	27	15 to 150
Range No.	GPH Water	Range No.	CC/Min. Water
30	1 to 8	35	5 to 50
31	1 to 16	36	10 to 150
32	4 to 40	37	20 to 200
33	5 to 60	38	50 to 500
Range No.	LPM Water		
40	.1 to 1.1		
41	.25 to 2.5		
42	.3 to 3.5		

MODEL CHART	
Model	Description
MMF-X	Standard MMF
MMF-X-PV	MMF with bottom mount valve
MMF-X-TMV	MMF with top mount valve
<b>How To Order:</b> MMF-Range No.-Valve	
<b>Example:</b> MMF-1-PV (Series MMF with .1-1 SCFH air range with valve)	

ACCESSORIES - MMF	
Model	Description
A-328	1/14" union

RANGE CHART - MMF	
Range No.	Range (SCFH Air)
1	.1 to 1
2	.2 to 2
10	1 to 10
50	5 to 50
100	10 to 100

OPTIONS	
To order add suffix:	Description
-NIST	NIST traceable calibration certificate



MMA-X tubing connections secured by clamp. "Standup" mounting clip shown.



Spring retainers on connection tubes secure panel mounted MMA-X. Compression union, P/N A-327 shown.



Model MMF mounts easily from front of panel. Drill two 9/32" or 5/16" dia. holes in panel on 2-1/16" centers. Insert mounting connector spuds. From rear, slide on the two spring retainers (furnished) and push on rubber or plastic tubing.



Model MMF connections. Connector at top, installed in panel, has retainer and flexible tubing in place. Connector at bottom shows alternative connection with metal or rigid plastic tubing, using a double compression nylon tube union (as Dwyer Part No. A-328).

# ULTRA-VIEW™ POLYSULFONE FLOWMETERS

High Corrosion - Resistant Body, Dual Scales



Shown with optional polysulfone fittings



Shown with optional polycarbonate shield

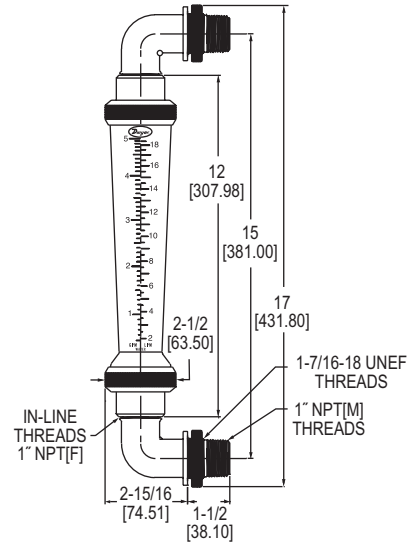

Shown with optional polysulfone fittings

The **Series UV Ultra-View™ Polysulfone Flowmeters** are an ultra-pure, laboratory grade flowmeter with a dual scale that measures flow in GPM and LPM of water, air and other compatible media. The Series UV is designed to withstand high temperatures up to 212°F (100°C) and pressures up to 150 psi (10.34 bar).

**FEATURES/BENEFITS**

- Corrosion-resistant polysulfone body ideal for applications where other flowmeters fail saving replacement cost and time
- Easy to clean body yields low maintenance costs
- Polycarbonate shield protects internal scale increasing product operating life
- Low installation costs with optional panel mount polysulfone fittings

**APPLICATIONS**

- Chill water flow
- Reverse osmosis systems
- Deionized water systems
- Potable water systems
- Remediation applications

**MODEL CHART**

Model	Range (GPM water)	Model	Range (SCFM air)
UV-0112	0.25 to 2.5 (1 to 9.5 LPM)	UV-A112	1 to 13 (30 to 370 LPM)
UV-1112	0.5 to 5.0 (2 to 19 LPM)	UV-B112	2.5 to 28 (70 to 780 LPM)
UV-2112	1.0 to 10.0 (4 to 38 LPM)	UV-C112	5 to 50 (70 to 1400 LPM)
UV-3112	2.0 to 20.0 (8 to 76 LPM)	UV-D112	14 to 100 (400 to 2800 LPM)
UV-4112	3.0 to 30.0 (12 to 112 LPM)		
UV-5112	4.0 to 40.0 (20 to 150 LPM)		

**Note:** For PVC 1" female NPT fittings, change 12 to 22.

**OPTIONS**

To order add suffix:	Description
-SHD	Protective polycarbonate shield
-NIST	NIST traceable calibration certificate

**ACCESSORIES**

Model	Description
A-801	Panel mount kit, polysulfone fittings
A-162	In-line fitting replacement kit. Two 1" female NPT connection fittings included in kit

**SPECIFICATIONS**

**Service:** Compatible liquids and gases.  
**Wetted Materials:** Polysulfone body and fittings, fluoroelastomer O-rings and virgin PTFE float.  
**Temperature Limits:** 35 to 212°F (2 to 100°C); 35 to 130°F (2 to 54°C) for PVC fitting option.  
**Pressure Limit:** 150 psi (10.34 bar).  
**Accuracy:** ±2% FS @ 70°F ±2°F (21.1°C) and 14.7 psia (in line connection rating only).  
**Repeatability:** ±1% FS @ 70°F ±2°F (21.1°C) and 14.7 psia (in line connection rating only).  
**Process Connections:** 1" female NPT. Optional 90° polysulfone elbow – 1" male NPT.  
**Scale Length:** 6" (152.40 mm) – 7" (177.80 mm), depending on model.  
**Fitting Torque:** Maximum 22 ft - lb.  
**Weight:** 1 lb (457 g) for 20 GPM range.  
**CAUTION:** Ball valves can have a "water cannon" effect on opening, creating pressure that exceeds the warranty ratings will damage the flowmeter. Series UV Flowmeters are for indoor use only or areas without direct sunlight. Polysulfone is adversely affected by ultraviolet light.

Flowmeters, Variable Area & In-Line



# POLYCARBONATE FLOWMETERS

Chemically Resistant, In-Line or Panel Mount Options, Adjustable Set Point Indicator Option



LFMA

LFMC

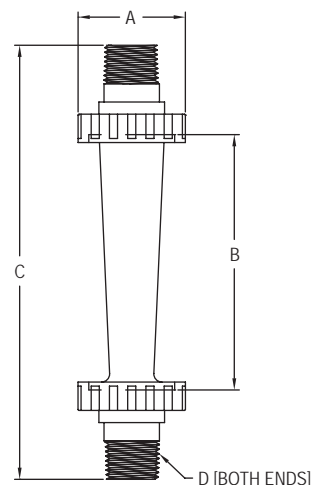

Model	AØ	B	C	D
LFMA	1-21/32 [42.07]	3-15/16 [100.01]	6-45/64 [170.26]	1/2 NPT
LFMB	1-63/64 [50.40]	6-5/16 [160.34]	8-55/64 [225.03]	1/2 NPT
LFMC	1-63/64 [50.40]	5-9/32 [134.14]	8-9/32 [210.34]	1/2 NPT
LFMD	2-21/64 [59.13]	6-45/64 [170.26]	9-27/32 [250.03]	3/4 NPT
LFME	2-27/32 [72.23]	8-55/64 [225.03]	12-19/64 [312.34]	1 NPT
LFMF	3-15/16 [100.01]	11-27/64 [290.12]	15-3/4 [400.05]	2 NPT

The **Series LFM Polycarbonate Flowmeters** are made of precision, injection molded polycarbonate bodies and fittings. This series consists of LFMA, LFMB, LFMC, LFMD, LFME and LFMF flowmeters with 3" (76 mm), 6" (152 mm), 5" (127 mm), 6" (152 mm), 8" (203 mm) and 11" (279 mm) respective scales. They feature dual, direct reading scales measuring in both GPM and LPM.

**FEATURES/BENEFITS**

- Low installation costs with standard in-line male NPT process connections and 90° elbow fitting for panel mount option
- Heat and chemically resistant polycarbonate body and fittings feature a low cost for high durability
- Textured background on flowmeter bodies enhance scale readability saving time
- Easy to clean bodies yield low maintenance costs
- Adjustable set point indicator allows for easy visual set point indication decreasing costly flow reading error for LFMC, LFMD, LFME & LFMF

**APPLICATIONS**

- Chill water flow
- Reverse osmosis systems
- Deionized water systems

MODEL CHART	
Model	Range (GPM Water)
LFMA-01-A2	0.1 to 1 (.5 to 4 LPM)
LFMA-02-A2	0.2 to 2 (1 to 7 LPM)
LFMA-03-A2	0.5 to 5 (1.8 to 18 LPM)
LFMB-04-A2	0.1 to 1 (.5 to 4 LPM)
LFMB-05-A2	0.2 to 2 (1 to 7 LPM)
LFMB-06-A2	0.5 to 5 (1.8 to 18 LPM)

MODEL CHART		
Model	Range (GPM Water)	Process Connection
LFMC-07-A2	0.25 to 2.5 (1 to 10 LPM)	1/2" male NPT
LFMC-08-A2	0.5 to 5 (1.8 to 18 LPM)	1/2" male NPT
LFMC-09-A2	0.8 to 8 (3 to 30 LPM)	1/2" male NPT
LFMD-10-C2	0.8 to 8 (3 to 30 LPM)	3/4" male NPT
LFMD-11-C2	1 to 10 (4 to 40 LPM)	3/4" male NPT
LFME-12-F2	1.2 to 12 (5 to 50 LPM)	1" male NPT
LFME-13-F2	2 to 20 (8 to 80 LPM)	1" male NPT
LFME-14-F2	2.5 to 25 (10 to 100 LPM)	1" male NPT
LFMF-15-I2	2.5 to 25 (10 to 100 LPM)	2" male NPT
LFMF-16-I2	5 to 45 (20 to 180 LPM)	2" male NPT
LFMF-17-I2	7 to 70 (25 to 250 LPM)	2" male NPT

OPTIONS	
Use order code:	Description
NISTCAL-FL1	NIST traceable calibration certificate

ACCESSORIES - LFMA	
Model	Description
A-560	20 mm metric union fittings - ABS
A-566	1/2" male NPT fittings - ABS

**SPECIFICATIONS**

**Service:** Water.  
**Wetted Materials:** Body: Polycarbonate; Flange nut: ABS; Float stop: LFMA, LFMB, LFMC: ABS; LFMD, LFME, LFMF: Polypropylene; O-rings: Fluoroelastomer; Rod & float: 316 SS; Connections: 20 mm & 63 mm metric union fittings: ABS; 32 mm & 40 mm metric union fittings: PVC; 1/2" & 3/4" male NPT fittings for LFMA, LFMB, LFMC: ABS; 3/4" male and female NPT fittings for LFMD: PA66 nylon; 1" & 2" male NPT fittings: PA66 nylon.  
**Pressure Limit:** 87 psi (6 bar) at 68°F (20°C); 90° elbow fittings 116 psi (8 bar) at 68°F (20°C).  
**Accuracy:** ±5%.  
**Process Connection:** LFMA: 1/2" male NPT. Optional 20 mm metric union; LFMB: 1/2" male NPT. Optional 20 mm metric union or 1/2" male NPT with 90° elbow; LFMC: 1/2" male NPT. Optional 20 mm metric union, 3/4" male NPT, or 1/2" male NPT with 90° elbow; LFMD: 3/4" male NPT. Optional 32 mm metric union, 3/4" female NPT, or 3/4" male NPT with 90° elbow; LFME: 1" male NPT. Optional 40 mm metric union, 1" female NPT, or 1" male NPT with 90° elbow; LFMF: 2" male NPT. Optional 63 mm metric union or 2" female NPT.  
**Weight:** LFMA: 2 oz (56.7 g); LFMB: 3 oz (85.0 g); LFMC: 4 oz (113.4 g); LFMD: 10 oz (283.5 g); LFME: 15 oz (425.2 g); LFMF: 40 oz (1.1 kg).  
**CAUTION:** Series LFM Flowmeters are for indoor use only or areas without direct sunlight. Polycarbonate is adversely affected by ultraviolet light.

ACCESSORIES - LFMB	
Model	Description
A-561	20 mm metric union fittings - ABS
A-567	1/2" male NPT fittings - ABS
A-575	1/2" male NPT with 90° elbow fittings - PVC

ACCESSORIES - LFMC	
Model	Description
A-562	20 mm metric union fittings - ABS
A-567	1/2" male NPT fittings - ABS
A-568	3/4" male NPT fittings - ABS
A-576	1/2" male NPT with 90° elbow fittings - PVC

ACCESSORIES - LFMD	
Model	Description
A-563	32 mm metric union fittings - PVC
A-569	3/4" male NPT fittings - nylon
A-572	3/4" female NPT fittings - nylon
A-577	3/4" male NPT with 90° elbow fittings - PVC

ACCESSORIES - LFME	
Model	Description
A-564	40 mm metric union fittings - PVC
A-570	1" male NPT fittings - nylon
A-573	1" female NPT fittings - nylon
A-578	1" male NPT with 90° elbow fittings - PVC

ACCESSORIES - LFMF	
Model	Description
A-565	63 mm metric union fittings - ABS
A-571	2" male NPT fittings - nylon
A-574	2" female NPT fittings - nylon

Flowmeters, Variable Area & In-Line

# VARIABLE AREA FLUOROPOLYMER FLOWMETER

In-Line, Chemically Inert

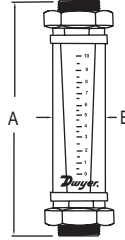

Connection	A	B
1/4"	5-11/16" [144]	1-1/4" [31.8]
3/8"	5-11/16" [144]	1-1/4" [31.8]
1/2"	10-1/2" [267]	2" [50.8]
3/4"	10-1/2" [267]	2" [50.8]

The **Series VAT Variable Area Fluoropolymer Flowmeter** is ideal for high purity or corrosive liquid applications. This series of flowmeters features a 0 to 10 scale for flow indication. Each unit is individually leak tested to a leak integrity rating of  $1 \times 10^{-7}$  sccs Helium or better.

**FEATURES/BENEFITS**

- Chemically inert wetted components yield long life even in corrosive liquid applications
- All units are individually leak tested for no additional cost

**APPLICATIONS**

- Chemical injectors
- Deionized water systems

MODEL CHART			
Model		Low Range	
With Valve	Without Valve	Connections	Flow Rate GPH (ml/min)
VAT-311	VAT-301	1/4" female NPT	1.98 (125)
VAT-312	VAT-302	1/4" female NPT	3.91 (250)
VAT-313	VAT-303	1/4" female NPT	6.34 (400)
VAT-314	VAT-304	1/4" female NPT	7.92 (500)
VAT-315	VAT-305	1/4" female NPT	15.85 (1000)
VAT-316	VAT-306	3/8" female NPT	31.69 (2000)
VAT-317	VAT-307	3/8" female NPT	39.62 (2500)
VAT-318	VAT-308	3/8" female NPT	47.54 (3000)
VAT-319	VAT-309	3/8" female NPT	79.23 (5000)

**SPECIFICATIONS**

**Service:** Compatible liquids.  
**Wetted Materials:** Flowtube: PFA; Float and end fittings: PTFE; Guide rods: PCTFE.  
**Temperature Limit:** 250°F (121°C).  
**Pressure Limit:** 100 psig (6.9 bar).  
**Accuracy:** ±5% FS @ 70°F (21.1°C) and 14.7 psia (1 atm absolute).  
**Process Connections:** See chart.  
**Leak Integrity:** 1 x 10<sup>-7</sup> sccs of helium.  
**Scale:** 0 to 10 markings.  
**Mounting:** Vertical, in-line.

MODEL CHART			
Model		High Range	
With Valve	Without Valve	Connections	Flow Rate GPM (L/min)
VAT-6110	VAT-6010	1/2" female NPT	3.43 (13)
VAT-6111	VAT-6011	1/2" female NPT	5.28 (20)
VAT-6112	VAT-6012	3/4" female NPT	7.93 (30)
VAT-6113	VAT-6013	3/4" female NPT	10.57 (40)
VAT-6114	VAT-6014	3/4" female NPT	11.89 (45)

OPTIONS	
Use order code:	Description
NISTCAL-FL1	NIST traceable calibration certificate

SERIES TVA

# ALL FLUOROPOLYMER FLOWMETERS

75 mm and 125 mm, 10:1 Turndown, Back Connect, Corrosive Resistant

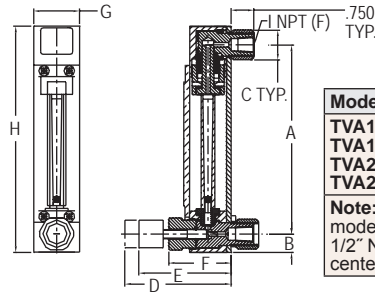

Model	A	B	C	D	E	F	G
TVA11XX	4.97 [126]	0.56 [14]	1.06 [27]	3.35 [85]	1.25 [32]	6.16 [156]	1/4
TVA13XX	4.97 [126]	0.56 [14]	1.25 [32]	4.65 [118]	1.50 [38]	6.16 [156]	3/8
TVA22XX	8.72 [221]	0.88 [22]	1.75 [44]	4.57 [116]	2.00 [51]	10.4 [264]	1/2
TVA24XX	8.47 [215]	1.00 [25]	1.75 [44]	5.95 [151]	2.25 [57]	10.4 [264]	3/4

**Note:** Panel mounting: Drill two holes: 3/4" dia. at 4.97" apart for 1/4" NPT models, 7/8" dia. at 4.97" apart for 3/8" NPT models, 1" dia. at 8.72" apart for 1/2" NPT models, and 1-1/4" dia. at 8.47" apart for 3/4" NPT models (center-to-center).

The **Series TVA All Fluoropolymer Flowmeters** are ideal for high purity or corrosive liquid applications. This series of flowmeters features a 0 to 10 scale graduations denoting a discrete flow rate.

**FEATURES/BENEFITS**

- Chemically inert wetted components yield long life even in corrosive liquid applications
- Low installation costs with standard back process connections for easy panel mounting

**APPLICATIONS**

- Chemical injectors
- Deionized water systems

MODEL CHART				
Model		Low Range		
With Valve	Without Valve	Length	Connections	Flow Rate Water GPH (ml/min)
TVA1113	TVA1103	75 mm	1/4" female NPT	6.34 (400)
TVA1115	TVA1105	75 mm	1/4" female NPT	15.9 (1000)
TVA1317	TVA1307	75 mm	3/8" female NPT	39.6 (2500)
TVA1319	TVA1309	75 mm	3/8" female NPT	79.2 (5000)

**SPECIFICATIONS**

**Service:** Compatible liquids.  
**Wetted Materials:** Flowtube: PFA; Float and end fittings: PTFE; Guide rods: PCTFE.  
**Temperature Limit:** 250°F (121°C).  
**Pressure Limit:** 100 psig (6.9 bar).  
**Accuracy:** ±5% FS @ 70°F (21.1°C) and 14.7 psia (1 atm absolute).  
**Repeatability:** ±0.25%.  
**Leak Integrity:** 1 x 10<sup>-7</sup> sccs of helium.  
**Scales:** 0 to 10 markings, 75 mm or 125 mm lengths.  
**Turn-down Ratio:** 10:1.  
**Mounting:** Vertical.

MODEL CHART				
Model		High Range		
With Valve	Without Valve	Length	Connections	Flow Rate Water GPM (L/min)
TVA22110	TVA22010	125 mm	1/2" female NPT	3.43 (13)
TVA24112	TVA24012	125 mm	3/4" female NPT	7.93 (30)
TVA24114	TVA24014	125 mm	3/4" female NPT	11.9 (45)

OPTIONS	
Use order code:	Description
NISTCAL-FL1	NIST traceable calibration certificate

# VARIABLE AREA GLASS FLOWMETERS

65 mm and 150 mm, ±2% FS Accuracy, Interchangeable Flowtubes, PTFE Options, Universal mm Scale

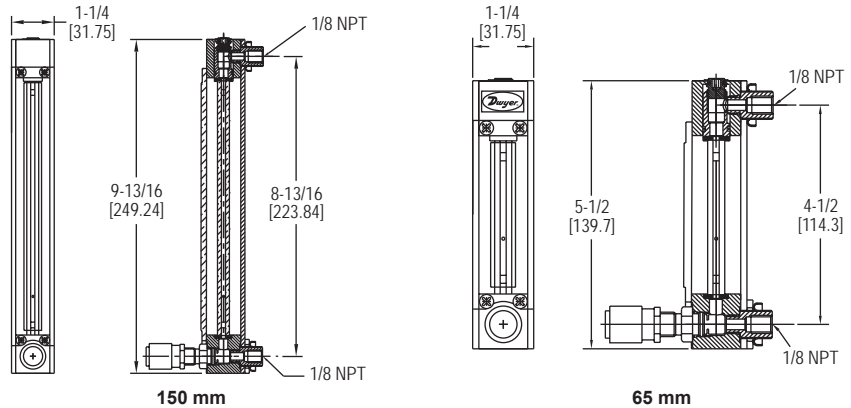

**150 mm**                      **65 mm**  
Panel mounting: Drill two 5/8" dia. holes at 4.5" apart for 65 mm models and 8.812" apart for 150 mm models (center-to-center).

The Series VA Variable Area Glass Flowmeters are designed with easy to read universal mm scale and supplied with correlation charts containing calibration data for air and water.

**FEATURES/BENEFITS**

- Permanently fused ceramic scale with vertical locator line reduces parallax and eye fatigue saving time
- Long operating life with thick polycarbonate front shield that protects tube from breakage and serves as a magnifying lens to enhance reading resolution
- Standard 6-turn needle valve for flow rate control eliminating the need for a separate valve reducing cost
- No additional installation required with optional acrylic tripod base which allows for self-standing bench mounting
- High precision metering valves with non-rising stems are available for high sensitivity control and resolution for very low flow rate

**APPLICATIONS**

- Gas or liquid metering
- Chemical processing
- Semiconductor systems
- Water and air pollution analysis systems
- Laboratory systems

MODEL CHART - METAL 65 MM SCALE					
Model				Max. Flow Rate	
Aluminum	SS	Brass	Float	Air SCFH (ml/min)	Water GPH (ml/min)
VA1043	VA1243	VA1343	Glass	0.104 (49)	0.009 (0.55)
VA1044	VA1244	-	SS	0.307 (145)	0.038 (2.38)
VA1045	VA1245	VA1345	Glass	0.220 (104)	0.028 (1.8)
VA1046	VA1246	-	SS	0.633 (299)	0.122 (7.7)
VA1047	VA1247	VA1347	Glass	0.43 (202)	0.041 (2.6)
VA1048	VA1248	-	SS	1.1 (522)	0.19 (12.0)
VA10423	VA12423	VA1349	Glass	2.29 (1081)	0.329 (20.8)
VA10424	VA12424	-	SS	4.51 (2129)	0.930 (58.7)
VA10411	VA12411	VA13411	Glass	2.65 (1249)	0.428 (27)
VA10412	VA12412	-	SS	5.34 (2520)	1.125 (71)
VA10413	VA12413	VA13413	Glass	4.32 (2040)	0.63 (40)
VA10414	VA12414	-	SS	8.45 (3990)	1.71 (108)
VA10417	VA12417	VA13417	Glass	13.4 (6318)	2.33 (147)
VA10418	VA12418	-	SS	25.5 (12058)	5.77 (364)
VA10419	VA12419	VA13419	Glass	27.9 (13153)	4.9 (309)
VA10420	VA12420	-	SS	52.3 (24680)	11.81 (745)
VA10421	VA12421	VA13421	Glass	49.1 (23169)	8.27 (522)
VA10422	VA12422	-	SS	89.2 (42094)	19.97 (1260)

MODEL CHART - METAL 150 MM SCALE					
Model				Max. Flow Rate	
Aluminum	SS	Brass	Float	Air SCFH (ml/min)	Water GPH (ml/min)
VA20429	VA22429	VA23429	Glass	0.792 (374)	0.087 (5.5)
VA20430	VA22430	-	SS	1.725 (814)	0.323 (20.4)
VA20433	VA22433	VA23433	Glass	4.9 (2313)	0.848 (54)
VA20434	VA22434	-	SS	9.67 (4562)	2.067 (130)
VA20435	VA22435	VA23435	Glass	8.07 (3807)	1.336 (84)
VA20436	VA22436	-	SS	16.08 (7590)	3.34 (217)
VA20437	VA22437	VA23437	Glass	18.38 (8678)	3.32 (210)
VA20438	VA22438	-	SS	35.5 (16737)	8.02 (506)
VA20439	VA22439	VA23439	Glass	49.9 (23564)	9.0 (568)
VA20440	VA22440	-	SS	93.9 (44336)	21.7 (1370)

OPTIONS	
Use order code:	Description
NISTCAL-FL1*	NIST traceable calibration certificate
*Specify media type (air or water) for NISTCAL option	

**SPECIFICATIONS**

**Service:** Compatible gases or liquids.  
**Wetted Materials:** Flowtube: Borosilicate glass; Floats: Glass or SS (sapphire, Carboloy and tantalum are optional); Float stops: PTFE; End fittings: Anodized aluminum, 316 SS, brass or PTFE; Packings: Fluoroelastomer, none on VAX5XX models; O-rings: Buna-N on aluminum models and brass models, fluoroelastomer on SS models, PTFE on VAX5XX models.  
**Temperature Limits:** 250°F (121°C); VAX5XX: -15 to 150°F (-26 to 65°C).  
**Pressure Limits:** 200 psig (13.8 bar); VAX5XX: 100 psig (6.7 bar).  
**Accuracy:** ±2% FS @ 70°F (21.1°C) and 14.7 psia (1 atm absolute); VA1043, VA1243, VA1343, VA25425, VA25025: ±5% FS @ 70°F (21.1°C) and 14.7 psia (1 @ absolute).  
**Repeatability:** ±0.25% FS.  
**Leak Rate:** 1 x 10<sup>-7</sup> sccs of helium.  
**Scales:** Universal 65 mm or 150 mm with correlation charts.  
**Turn-Down Ratio:** 10:1.  
**Connections:** Two 1/8" female NPT.  
**Mounting:** Vertical.  
**Valve:** 6-turn needle (standard), optional 16-turn high precision valve.  
**Valve Orifice:** Acetal on aluminum models and brass models, PCTFE on stainless steel models, PTFE on VAX5XX models.

MODEL CHART - PTFE 65 MM SCALE				
Model			Max. Flow Rate	
With Valve	Without Valve	Float	Air SCFH (ml/min)	Water GPH (ml/min)
VA1545	VA1505	Glass	0.220 (104)	0.028 (1.8)
VA1547	VA1507	Glass	0.428 (202)	0.047 (2.95)
VA15411	VA15011	Glass	2.646 (1249)	0.428 (27)
VA15413	VA15013	Glass	4.322 (2040)	0.630 (39.7)
VA15417	VA15017	Glass	13.39 (6318)	2.33 (147)
VA15419	VA15019	Glass	27.9 (13153)	4.9 (309)
VA15421	VA15021	Glass	49 (23169)	8.27 (522)

Note: VAX5XX models indicate PTFE units.

MODEL CHART - PTFE 150 MM SCALE				
Model			Max. Flow Rate	
With Valve	Without Valve	Float	Air SCFH (ml/min)	Water GPH (ml/min)
VA25425	VA25025	Glass	0.104 (49)	0.01 (0.61)
VA25429	VA25029	Glass	0.792 (374)	0.087 (5.5)
VA25431	VA25031	Glass	1.75 (825)	0.262 (16.5)
VA25435	VA25035	Glass	8.07 (3807)	1.34 (84.3)
VA25437	VA25037	Glass	18.39 (8678)	3.32 (209)

Note: VAX5XX models indicate PTFE units.

ACCESSORIES	
Model	Description
VA81	High precision valve, 316 SS, 0.42 SCFH capacity
VA82	High precision valve, 316 SS, 0.85 SCFH capacity
VA83	High precision valve, 316 SS, 2.12 SCFH capacity
VA84	High precision valve, 316 SS, 4.87 SCFH capacity
VA85	High precision valve, 316 SS, 13.14 SCFH capacity
VA86	High precision valve, 316 SS, 45.55 SCFH capacity
VA7	Acrylic tripod for single meter

USA: California Proposition 65  
 ⚠WARNING: Cancer and Reproductive Harm - www.P65Warnings.ca.gov

# DIRECT READING GLASS FLOWMETERS

65 mm and 150 mm, Interchangeable Flowtubes, Direct Reading Scales

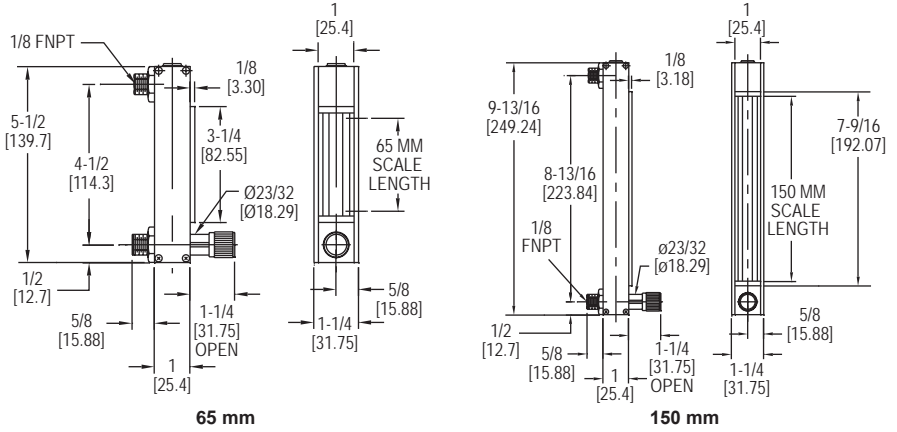

Panel mounting: Drill two 5/8" dia. holes at 4.5" apart for 65mm models and 8.812" apart for 150 mm models (center-to-center).

The **Series DR Direct Reading Glass Flowmeters** are ideal for the direct flow measurement of air, water, and other commonly used gases. These flowmeters are designed with direct read scales with no need for correlation charts. They feature borosilicate glass tubes in 150 mm or 65 mm scales with aluminum and SS metering valve options.

**FEATURES/BENEFITS**

- Permanently fused ceramic scale with vertical locator line, reflective lens background and 1.5 X magnification lens reduces parallax and eye fatigue saving time
- Long operating life with thick polycarbonate front shield that protects tube from breakage and serves as a magnifying lens to enhance reading resolution
- Optional needle valve for flow rate control eliminating the need for a separate valve reducing cost
- Increased protection with included safety blow-out back panel for added safety

**APPLICATIONS**

- Gas or liquid metering
- Paper manufacturing
- Chemical processing
- Semiconductor systems
- Water and air pollution analysis systems
- Laboratory systems

**SPECIFICATIONS**

**Service:** Compatible gases or liquids.  
**Wetting Materials:** Flowtube: Borosilicate glass; Float: 316 SS (black glass as indicated); Float stops: PTFE; End fittings: Anodized aluminum or 316 SS; O-rings: Buna-N on aluminum models and fluoroelastomer on SS models.  
**Temperature Limit:** 250°F (121°C).  
**Pressure Limit:** 250 psig (17 bar).  
**Accuracy:** ±5% FS @ 70°F (21.1°C) and 14.7 psia (1 atm absolute).  
**Repeatability:** ±0.25% of scale reading.  
**Scales:** Direct reading 65 mm or 150 mm scales for air or water.  
**Turn-Down Ratio:** 10:1.  
**Connection:** 1/8" female NPT.  
**Mounting:** Vertical.  
**Valve:** 6-turn needle (standard on models with valve).

Flowmeters, Variable Area & In-Line

MODEL CHART - 65 MM SCALE				
Model Without Valve		Model With Valve		Max. Flow Rate
Aluminum	SS	Aluminum	SS	Air SCFH (SCCM)
DR10010*	DR12010*	DR10410*	DR12410*	0.24 (130†)
DR10022	DR12022	DR10422	DR12422	0.65 (300†)
DR10030*	DR12030*	DR10430*	DR12430*	1.1 (500†)
DR10042	DR12042	DR10442	DR12442	2.2 (1000†)

Note: Add suffix "M" for metric scale. \*Denotes glass float.  
 †Metric models use ccm as unit of measure for water & LPM for air.

MODEL CHART - 65 MM SCALE				
Model Without Valve		Model With Valve		Max. Flow Rate
Aluminum	SS	Aluminum	SS	Air SCFH (L/min)
DR10062	DR12062	DR10462	DR12462	5.6 (2.1)
DR10070*	DR12070*	DR10470*	DR12470*	11 (5)
DR10082	DR12082	DR10482	DR12482	20 (9.5)
DR10090*	DR12090*	DR10490*	DR12490*	55 (24)
DR100102	DR120102	DR104102	DR124102	100 (50)

Note: Add suffix "M" for metric scale. \*Denotes glass float.

MODEL CHART - 65 MM SCALE				
Model Without Valve		Model With Valve		Max. Flow Rate
Aluminum	SS	Aluminum	SS	Water GPH (SCCM)
DR100120*	DR120120*	DR104120*	DR124120*	0.02 (1.5)
DR100132	DR120132	DR104132	DR124132	0.1 (6.5)
DR100140*	DR120140*	DR104140*	DR124140*	0.13 (8)
DR100152	DR120152	DR104152	DR124152	0.36 (24)
DR100172	DR120172	DR104172	DR124172	0.9 (55)
DR100180*	DR120180*	DR104180*	DR124180*	2.2 (140)
DR100192	DR120192	DR104192	DR124192	4.4 (280)
DR100200*	DR120200*	DR104200*	DR124200*	10 (600)
DR100212	DR120212	DR104212	DR124212	24 (1500)

Note: Add suffix "M" for metric scale. \*Denotes glass float.

MODEL CHART - 150 MM SCALE				
Model Without Valve		Model With Valve		Max. Flow Rate
Aluminum	SS	Aluminum	SS	Air SCFH (SCCM)
DR20032	DR22032	DR20432	DR22432	0.33 (160)
DR20082	DR22082	DR20482	DR22482	0.54 (270)
DR200132	DR220132	DR204132	DR224132	2 (840)

Note: Add suffix "M" for metric scale.

MODEL CHART - 150 MM SCALE				
Model Without Valve		Model With Valve		Max. Flow Rate
Aluminum	SS	Aluminum	SS	Air SCFH (L/min)
DR200182	DR220182	DR204182	DR224182	3.8 (1.8)
DR200232	DR220232	DR204232	DR224232	10 (4.8)
DR200282	DR220282	DR204282	DR224282	16 (7.5)
DR200332	DR220332	DR204332	DR224332	35 (16)
DR200382	DR220382	DR204382	DR224382	90 (44)

Note: Add suffix "M" for metric scale.

MODEL CHART - 150 MM SCALE				
Model Without Valve		Model With Valve		Max. Flow Rate
Aluminum	SS	Aluminum	SS	Water GPH (SCCM)
DR200432	DR220432	DR204432	DR224432	0.05 (3.2)
DR200482	DR220482	DR204482	DR224482	0.075 (4.6)
DR200532	DR220532	DR204532	DR224532	0.34 (21)
DR200582	DR220582	DR204582	DR224582	0.75 (46)
DR200632	DR220632	DR204632	DR224632	2.2 (140)
DR200682**	DR220682	DR204682**	DR224682	3.6 (230)
DR200732	DR220732	DR204732	DR224732	7.5 (480)
DR200782	DR220782	DR204782	DR224782	21 (1300)

Note: Add suffix "M" for metric scale. \*\*Not available in metric scale.

OPTIONS	
Use order code:	Description
NISTCAL-FL1	NIST traceable calibration certificate



# INDUSTRIAL DIRECT READING FLOWMETERS

Air/Water Direct Reading Scale, 304 SS Protective Shield

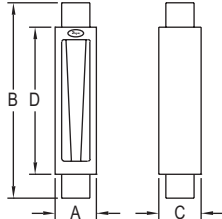

DIMENSIONS					
Tube Size	Female NPT	A	B	C	D
1 and 2	1/2"	2 [50.8]	9.54 [242]	2.25 [57.2]	8.04 [204]
3 and 4	1"	3.5 [89]	13.69 [348]	3.75 [95.3]	10.50 [267]
5 and 6	2"	5 [127]	15.59 [396]	5.25 [133]	11.55 [293]

The **Series IF Industrial Direct Reading Flowmeters** are flowmeters that directly measure flow rates up to 116 GPM (439 LPM) for water and 250 SCFM (7080 LPM) for air service.

**FEATURES/BENEFITS**

- Direct read scales with no need for correlation charts saves time
- Detachable, clear 3/16" thick polycarbonate front shield provides protection at maximum rated temperature and pressure

**APPLICATIONS**

- Gas or liquid metering
- Industrial pneumatic or hydraulic systems

**SPECIFICATIONS**

<b>Service:</b> Liquids or gases.	<b>Accuracy:</b> ±3% of FS.
<b>Wetted Materials:</b> Flowtube: Borosilicate glass; float, guide rods, float stops, end; Fittings: 316 SS; O-rings: Fluoroelastomer.	<b>Repeatability:</b> ±0.5% of FS.
<b>Temperature Limit:</b> 200°F (93°C).	<b>Turn-Down Ratio:</b> 10:1.
<b>Pressure Limit:</b> 200 psi (13.8 bar); 125 psi for tube size 5 & 6.	<b>Scale:</b> Dual scale GPM and SCFM.
	<b>Process Connection:</b> See table.
	<b>Mounting:</b> Vertical.
	<b>Front Shield:</b> Polycarbonate.
	<b>Side Panels:</b> 304 SS.

MODEL CHART														
Model	Maximum Flow Rate		Tube Size	Press. Drop (in H <sub>2</sub> O)	Model	Maximum Flow Rate		Tube Size	Press. Drop (in H <sub>2</sub> O)	Model	Maximum Flow Rate		Tube Size	Press. Drop (in H <sub>2</sub> O)
	Water GPM (LPM)	Air SCFM (LPM)				Water GPM (LPM)	Air SCFM (LPM)				Water GPM (LPM)	Air SCFM (LPM)		
IF2700	0.25 (0.95)	1.2 (35)	1	-	IF2708	6 (20)	25.5 (725)	4	5	IF2716	41 (155)	160 (4531)	6	5
IF2701	0.36 (1.3)	1.7 (50)	1	2	IF2709	7.4 (27.5)	30 (900)	4	6	IF2717	44 (167)	180 (5098)	5	30
IF2702	0.76 (3.0)	3.3 (90)	1	5	IF2710	9.6 (35)	40 (1200)	4	10	IF2718	60 (227)	245 (6938)	6	16
IF2703	1 (3.7)	4.2 (120)	2	6	IF2711	11 (40)	47.5 (1400)	4	13	IF2719	61 (231)	250 (7080)	5	40
IF2704	1.5 (5.6)	6.5 (180)	2	-	IF2712	14 (50)	62 (1800)	4	24	IF2720	86 (326)	-	6	25
IF2705	2.2 (8.2)	8.5 (250)	2	10	IF2713	20 (75)	90 (2600)	4	39	IF2721	116 (439)	-	6	45
IF2706	3.8 (14)	16 (475)	3	10	IF2714	22 (83)	90 (2550)	5	16					
IF2707	5 (18)	21.5 (650)	3	14	IF2715	26 (98)	-	4	70					

OPTIONS	
Use order code:	Description
NISTCAL-FL1	NIST traceable calibration certificate

**SERIES RSF**

# ROTATABLE SCALE FLOWMETERS

Dual, Rotatable Direct Reading Scales for Air and Water



In-line meter



Panel mount meter

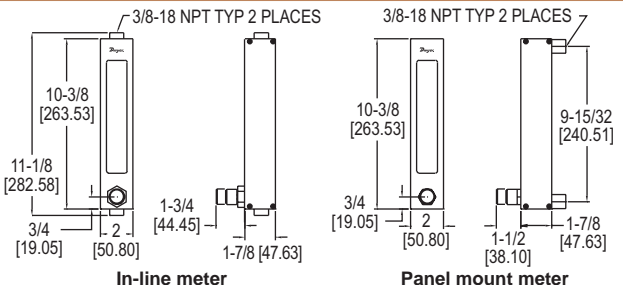

The **Series RSF Rotatable Scale Flowmeters** are ideal for the direct flow measurement of air, water, and other commonly used gases. These flowmeters are designed with direct read scales with no need for correlation charts and graduations are marked on a rotating, polycarbonate tube shield. They feature borosilicate glass tubes with brass and SS metering valve options.

**FEATURES/BENEFITS**

- Reflective lens background and 1.5 X magnification lens reduces parallax and eye fatigue saving time and allowing for a more accurate reading
- Long operating life with thick polycarbonate front shield that protects tube from breakage and serves as a magnifying lens to enhance reading resolution
- Increased protection with included safety blow-out back panel for added safety in the event of breakage

**APPLICATIONS**

- Gas or liquid metering
- Water and air pollution analysis systems

**SPECIFICATIONS**

<b>Service:</b> Compatible gases or liquids.	<b>Accuracy:</b> ±7% FS.
<b>Wetted Materials:</b> Flowtube: Borosilicate glass; Float: Brass/SS models: 316 SS; PTFE models: PTFE; Float stops: Brass/SS models: 316 SS; PTFE models: PTFE; End fittings: Brass/SS models: Brass or 316 SS; PTFE models: PTFE; O-rings: Brass/SS models: Fluoroelastomer; PTFE models: PTFE.	<b>Repeatability:</b> ±0.25% FS.
<b>Temperature Limit:</b> 250°F (121°C); PTFE models: 150°F (65°C).	<b>Scale:</b> Direct Reading 127 mm scales for air and water.
<b>Pressure Limit:</b> 150 psig (10.34 bar) @ 200°F (93°C). PTFE models: 100 psig (6.7 bar).	<b>Turn-Down Ratio:</b> 10:1.
	<b>Connections:</b> Two 3/8" female NPT.
	<b>Mounting:</b> Vertical or panel mount.
	<b>Panel Cutout:</b> Drill two 7/8" diameter holes 9.469" (240.5 mm) apart (for panel mount meters only).
	<b>Valve:</b> 6-turn needle (standard on models indicating "with valve").

MODEL CHART											
Brass & SS Vertical In-Line Meters						Brass & SS Panel Mount Meters					
Model Without Valve		Model With Valve		Max. Flow Rate		Model Without Valve		Model With Valve		Max. Flow Rate	
Brass	SS	Brass	SS	Air SCFM (SLPM)	Water GPM (LPM)	Brass	SS	Brass	SS	Air SCFM (SLPM)	Water GPM (LPM)
RSF011	RSF111	RSF011V	RSF111V	5 (140)	1.2 (4)	RSF021	RSF121	RSF021V	RSF121V	5 (140)	1.2 (4)
RSF012	RSF112	RSF012V	RSF112V	10 (280)	2 (8)	RSF022	RSF122	RSF022V	RSF122V	10 (280)	2 (8)
RSF013	RSF113	RSF013V	RSF113V	15 (425)	3 (11.5)	RSF023	RSF123	RSF023V	RSF123V	15 (425)	3 (11.5)
RSF014	RSF114	RSF014V	RSF114V	20 (575)	4 (15)	RSF024	RSF124	RSF024V	RSF124V	20 (575)	4 (15)
RSF015	RSF115	RSF015V	RSF115V	30 (900)	5 (20)	RSF025	RSF125	RSF025V	RSF125V	30 (900)	5 (20)

Note: For PTFE models select RSF2XX (not available for all models).

OPTIONS	
Use order code:	Description
NISTCAL-FL1	NIST traceable calibration certificate

USA: California Proposition 65  
 ⚠ WARNING: Cancer and Reproductive Harm - www.P65Warnings.ca.gov



SERIES HFPC & HFPS

# PLASTIC FLOWMETERS

Mount in any Position, Corrosive Resistant

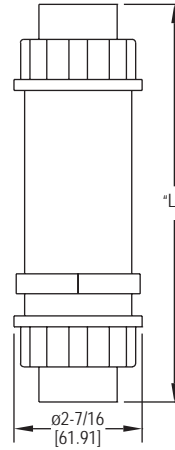

Meter Size	DIM "L"
1/2" male	7-11/16 [195.26]
1/2" female	7-5/32 [181.76]
3/4" male	8-1/32 [204.00]
3/4" female	7-9/16 [192.09]
1" male	8-3/32 [205.58]
1" female	7-9/16 [192.09]

The **Series HFPC & HFPS Plastic Flowmeters** are a series of clear body, in-line flowmeters. This Series consists of the HFPC polycarbonate body flowmeter and the HFPS polysulfone body flowmeter. These flowmeters have dual scales measuring both in GPM and LPM.

### FEATURES/BENEFITS

- Clear body allows for visual inspection of the fluid conditions and immediate problem detection
- Reduce cost with multi position mounting to accommodate direction of flow
- Rugged construction allows for high pressure and temperature rating for long operation life
- Injection molded, polycarbonate or polysulfone bodies yield great repeatability

### APPLICATIONS

- Chemical processing
- Pulp and paper
- Process control
- Fluid power
- Hydraulic flow
- Heating loop flow

### SPECIFICATIONS

**Service:** Compatible liquids.  
**Wetted Materials:** HFPC: Polycarbonate body, Buna-N seals, SS spring, Polysulfone connections; HFPS: Polysulfone body, Buna-N seals, SS spring, polysulfone connections.  
**Pressure Limit:** 325 psig (22.4 bar).  
**Temperature Limit:** HFPC: 200°F (93°C); HFPS: 250°F (121°C).  
**Accuracy:** ±5% FS.  
**Repeatability:** ±1% FS.  
**Pressure Loss:** See chart.  
**Weight:** Standard models 1 lb (453.6 g). Models with optional brass connections 2 lb (907 g).  
**CAUTION:** Series HFPC & HFPS Flowmeters are for indoor use only or areas without direct sunlight. Polycarbonate & polysulfone are adversely affected by ultraviolet light.

MODEL CHART						
Example	HF	PC	-1	-1	-BC	HFPC-1-1-BC
Series	HF					HF plastic flow meters
Wetted Parts		PC				Polycarbonate body, polysulfone connections
		PS				Polysulfone body, polysulfone connections
Connection			1			1/2" female NPT
			2			3/4" female NPT
			3			1" female NPT
			4			1/2" male NPT brass connections only
			5			3/4" male NPT brass connections only
			6			1" male NPT brass connections only
			7			1/2" female BSPP
			8			3/4" female BSPP
			9			1" female BSPP
Range			1			.5 to 5 GPM (1 to 19 LPM)
			2			1 to 10 GPM (3.8 to 38 LPM)
			3			2 to 15 GPM (7.5 to 55 LPM)
			4			3 to 30 GPM (11 to 113 LPM)
Option					BC	Brass connections

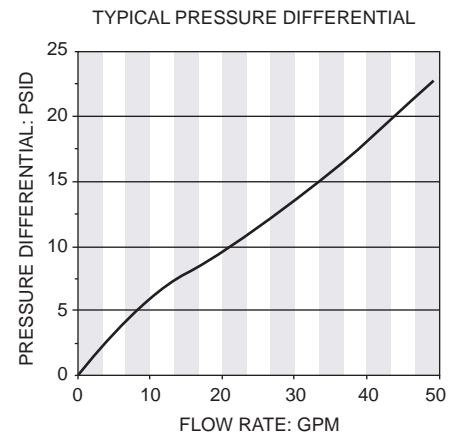

OPTIONS	
Use order code:	Description
NISTCAL-FL1	NIST traceable calibration certificate

USA: California Proposition 65  
 ⚠ WARNING: Cancer and Reproductive Harm - www.P65Warnings.ca.gov

# IN-LINE FLOW MONITOR

For Air, Water or Caustic Fluids,  $\pm 2\%$  FS, Unrestricted Mounting, High Temperature and Pressure Options

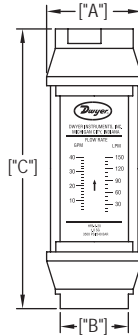

Valve Size	"A" Reference	"B" Wrench Flats	"C" Reference
1/8 NPT	1.25	0.875	4.813
1/4 to 1/2 NPT	1.875	1.250	6.562
3/4 to 1 NPT	2.375	1.750	7.125
1-1/4 to 1-1/2 NPT	3.500	2.250	10.125
2 NPT	3.500	2.250	12.625

The **Series HF In-Line Flow Monitor** is ruggedly constructed and ideal for direct measurement for a range of compatible gases, oil or water based liquids. This Series is designed based on a floating orifice disk and variable area flow measurement. Flowing media forces linear motion of the orifice disk and a ring shaped magnet which ride on a tapered center shaft. The transfer magnet drives a clearly visible magnet follower located outside the flow tube, and a ring on the magnet follower indicates flow rate on the direct reading scale.

### FEATURES/BENEFITS

- This unique design allows accurate performance with fluid viscosities up to 500 SSU
- All internal wetted parts are contained inside a sealed metal tubular casing assuring a virtually maintenance-free unit
- Increased application versatility with no inlet or outlet straight plumbing requirement and can be mounted horizontally, vertically, or inverted
- Rugged construction allows for high pressure and temperature rating for long operation life

### APPLICATIONS

- Setting pressure relief valves
- Fluid handling equipment
- Detecting low-flow rates for lubricating liquids
- Pulp and paper
- Industrial maintenance
- Fluid power
- Heating loop flow

MODEL CHART - BRASS BODY FOR WATER BASED FLUIDS (NON-STEAM)		
Model	Connection Size	Range: Water GPM (LPM)*
HFB-2-05	1/2" female NPT	0.5 to 5.0 (1 to 19)
HFB-3-15	3/4" female NPT	2 to 15 (7.5 to 55)
HFB-3-20	3/4" female NPT	2 to 20 (7.5 to 75)
HFB-4-35	1" female NPT	5 to 35 (19 to 130)
HFB-5-50	1-1/2" female NPT	5 to 50 (19 to 189)
HFB-5-100	1-1/2" female NPT	10 to 100 (38 to 379)
HFB-6-75	2" female NPT	8 to 75 (31 to 284)
HFB-6-150	2" female NPT	20 to 150 (76 to 568)

\*Dual scale range

MODEL CHART - ALUMINUM, BRASS, AND STAINLESS STEEL FOR AIR AND OTHER NON-CORROSIVE GASES				
Aluminum Model	Brass Model	Stainless Steel Model	Connection (NPT female, dry seal)	Range: SCFM (LPS)*
HFA-1-001	HFB-1-001	HFS-1-001	1/4"	1.5 to 12 (0.5 to 5.5)
HFA-1-002	HFB-1-002	HFS-1-002	1/4"	4 to 23 (2 to 10)
HFA-1-003	HFB-1-003	HFS-1-003	1/4"	5 to 50 (2.5 to 25)
HFA-1-004	HFB-1-004	HFS-1-004	1/4"	10 to 100 (5 to 45)
HFA-8-001	HFB-8-001	HFS-8-001	3/8"	1.5 to 12 (.5 to 5.5)
HFA-8-002	HFB-8-002	HFS-8-002	3/8"	4 to 23 (2 to 10)
HFA-8-003	HFB-8-003	HFS-8-003	3/8"	5 to 50 (2.5 to 25)
HFA-8-004	HFB-8-004	HFS-8-004	3/8"	10 to 100 (5 to 45)
HFA-2-001	HFB-2-001	HFS-2-001	1/2"	1.5 to 12 (.5 to 5.5)
HFA-2-002	HFB-2-002	HFS-2-002	1/2"	4 to 23 (2 to 10)
HFA-2-003	HFB-2-003	HFS-2-003	1/2"	5 to 50 (2.5 to 25)
HFA-2-004	HFB-2-004	HFS-2-004	1/2"	10 to 100 (5 to 45)
HFA-3-003	HFB-3-003	HFS-3-003	3/4"	5 to 50 (3 to 23)
HFA-3-004	HFB-3-004	HFS-3-004	3/4"	10 to 100 (4 to 48)
HFA-3-005	HFB-3-005	HFS-3-005	3/4"	15 to 150 (8 to 56)
HFA-3-006	HFB-3-006	HFS-3-006	3/4"	30 to 330 (20 to 150)
HFA-4-003	HFB-4-003	HFS-4-003	1"	5 to 50 (3 to 23)
HFA-4-004	HFB-4-004	HFS-4-004	1"	10 to 100 (4 to 48)
HFA-4-005	HFB-4-005	HFS-4-005	1"	15 to 150 (8 to 56)
HFA-4-006	HFB-4-006	HFS-4-006	1"	30 to 330 (20 to 150)
HFA-9-007	HFB-9-007	HFS-9-007	1-1/4"	30 to 470 (15 to 220)
HFA-9-008	HFB-9-008	HFS-9-008	1-1/4"	150 to 900 (75 to 425)
HFA-5-007	HFB-5-007	HFS-5-007	1-1/2"	30 to 470 (15 to 220)
HFA-5-008	HFB-5-008	HFS-5-008	1-1/2"	150 to 900 (75 to 425)

\*Dual scale range

### SPECIFICATIONS

**Service:** Compatible gases or liquids.  
**Wetted Materials:** HFA: Aluminum casing, Buna-N seals, PTFE coated Alnico magnet, SS disk; HFB: Brass casing, Buna-N seals, PTFE coated Alnico magnet, SS disk; HFS: 303 SS casing, FKM seals with PTFE backup, PTFE coated Alnico magnet, SS disk.  
**Maximum Viscosity:** 500 SSU.  
**Temperature Limits:** 240°F (116°C).  
**Pressure Limits:** HFA, HFB, HFL and HFH models: 600 psig (41 bar) for air and gas, 3500 psig (241 bar) for liquids; HFS model: 1000 psig (70 bar) for air and gas, 6000 psig (413 bar) for liquids.  
**Accuracy:**  $\pm 2\%$  FS.  
**Repeatability:**  $\pm 1\%$  of FS.  
**Shipping Weight:** 1/4" to 1/2" female NPT models: 2 lb (0.9 kg); 3/4 to 1" female NPT models: 3.5 lb (1.59 kg); 1-1/2" female NPT models: 11 lb (5 kg); 2" female NPT models: 13.5 lb (6.12 kg).

**Note:** Series HF monitors are recommended for use with system filtration of at least 74 microns or a 200 mesh screen

MODEL CHART - ALUMINUM BODY FOR OIL BASED FLUIDS		
Model	Connection Size	Range: Oil GPM (LPM)*
HFL-2-05	1/2" female NPT	0.5 to 5.0 (1 to 19)
HFL-4-25	1" female NPT	2 to 25 (7.5 to 95)

\*Dual scale range

MODEL CHART - 304 SS BODY FOR HIGH-PRESSURE FLUIDS		
Model	Connection Size	Range: Water GPM (LPM)*
HFS-2-02	1/2" female NPT	0.2 to 2.0 (0.75 to 7.5)
HFS-2-10	1/2" female NPT	0.5 to 10 (1.9 to 38)

\*Dual scale range



SERIES RMV

# RATE-MASTER® DIAL-TYPE FLOWMETER

Brass Body, Three Ranges to 20 GPM Water, Shatterproof Construction

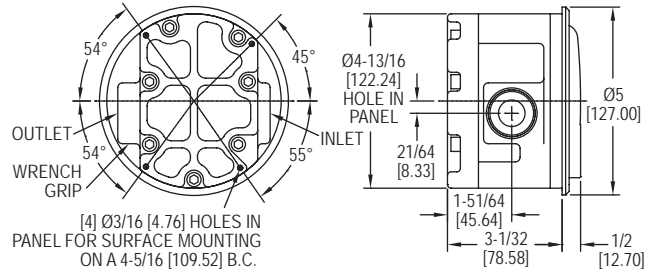

The **Series RMV Rate-Master® Dial-Type Flowmeter** measures higher water flow rates with ±2% of full-scale accuracy at an affordable price. Stocked models are fitted with 1" female NPT inlet and outlet; 3/4" and 1/2" sizes are also available. Install in line, supported by piping or flush panel mount with complete hardware package included.

**FEATURES/BENEFITS**

- Rugged forged brass housing yields great compatibility and strength, allowing the unit to withstand system pressures to 1000 psig (68.9 bar)
- Shatter proof construction, unlike glass tube variable area flowmeters, yields long operation life

**APPLICATIONS**

- Monitor coolant flow through ingot heaters, high-amp switchgear, resistance welders, heat exchangers, compressors, scrubbers
- Monitor water consumption to different processes and operations for more efficient operations
- Calculate required fill or drain times for tanks, water towers

**OPTIONS**

To order add suffix:	Description
-NIST	NIST traceable calibration certificate
<b>Example:</b> RMV-1-3-NIST	

**SPECIFICATIONS**

**Service:** Compatible liquids.  
**Wetted Materials:** Brass, copper, 302 SS, sintered barium ferrite.  
**Temperature Limits:** 20 to 200°F (-6.7 to 93°C).  
**Pressure Limit:** 1000 psig (68.9 bar).  
**Pressure Drop:** 0 to 5 GPM: 3.2 psid; 0 to 10 GPM: 5.3 psid; 0 to 20 GPM: 10.4 psid.  
**Accuracy:** ±2% of FS.  
**Size:** Diameter dial face 4" (101.6 mm).  
**Process Connections:** See chart.  
**Maximum Flow:** 1.5 x full-scale reading.  
**Weight:** 9 lb (4.08 kg).

**MODEL CHART**

Model	Range, GPM Water	Connection Size
RMV-1-3	0 to 5	1" female NPT
RMV-2-3	0 to 10	1" female NPT
RMV-3-3	0 to 20	1" female NPT
RMV-1-2	0 to 5	3/4" female NPT
RMV-2-2	0 to 10	3/4" female NPT
RMV-3-2	0 to 20	3/4" female NPT
RMV-1-1	0 to 5	1/2" female NPT
RMV-2-1	0 to 10	1/2" female NPT
RMV-3-1	0 to 20	1/2" female NPT

USA: California Proposition 65

⚠WARNING: Cancer and Reproductive Harm - www.P65Warnings.ca.gov

SERIES RMVII

# RATE-MASTER® DIAL-TYPE FLOWMETER

For Panel Mounting, Three Ranges to 10 GPM Water, High Pressure Limits

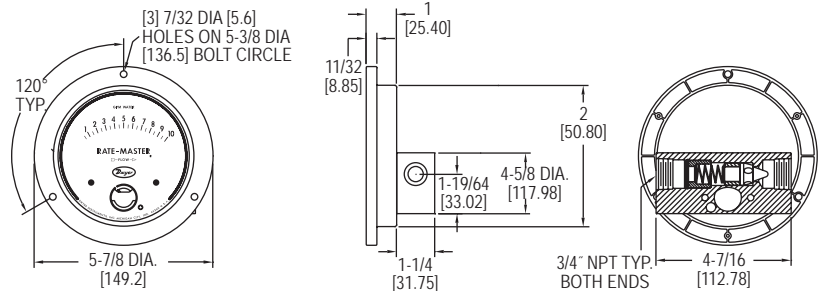

\*FITS IN ANSI STANDARD 4.940 [125.5] PANEL CUTOUT

The **Series RMVII Rate-Master® Dial-Type Flowmeter** consists of a machined brass meter body which is ideally suited for water flows with ±5% of full-scale accuracy. Body design fits standard 4-1/2" mounting hole layouts per ANSI B40.1. Inlet and outlet threads are standard 3/4" female NPT.

**FEATURES/BENEFITS**

- Unique construction fully isolates flowing media from gage front for leak-proof operation at pressures up to 3000 psig (206.7 bar)
- Target-type design combined with a damage resistant magnetic linkage, drive a pointer over easy-to-read litho scale
- Shatter proof construction, unlike glass tube variable area flowmeters, yields long operation life

**APPLICATIONS**

- Monitor coolant flow through ingot heaters, high-amp switchgear, resistance welders, heat exchangers, compressors, scrubbers
- Monitor water consumption to different processes and operations for more efficient operations
- Calculate required fill or drain times for tanks, water towers

**OPTIONS**

To order add suffix:	Description
-NIST	NIST traceable calibration certificate
<b>Example:</b> RMVII-1-NIST	

**SPECIFICATIONS**

**Service:** Compatible gases, liquids and oils.  
**Wetted Materials:** Brass, 302 SS, sintered barium ferrite, polyacetyl.  
**Temperature Limit:** 200°F (93°C).  
**Pressure Limit:** 3000 psig (206 bar).  
**Pressure Drop:** 0 to 5 GPM: 3.2 psid; 0 to 10 GPM: 5.3 psid; 0 to 20 GPM: 10.4 psid.  
**Accuracy:** ±5% of FS.  
**Size:** Diameter dial face 4.5" (114.3 mm).  
**Process Connections:** 3/4" female NPT.  
**Weight:** 2 lb, 14 oz (1.3 kg).

**MODEL CHART**

Model	Range GPM Water	Range SCFM	Range LPM Air	Range GPM Oil	Range LPM Oil
RMVII-1	0 to 3	-	-	-	-
RMVII-3	0 to 5	-	-	-	-
RMVII-6	0 to 10	-	-	-	-
RMVII-10	-	0 to 10	0 to 280	-	-
RMVII-12	-	0 to 30	0 to 850	-	-
RMVII-14	-	0 to 50	0 to 1400	-	-
RMVII-20	-	-	-	0 to 2.2	0 to 8
RMVII-21	-	-	-	0 to 4.0	0 to 15
RMVII-22	-	-	-	0 to 8.5	0 to 32

USA: California Proposition 65

⚠WARNING: Cancer and Reproductive Harm - www.P65Warnings.ca.gov



# VENTURI FLOWMETER WITH MAGNEHELIC® GAGE

±2.5% Accuracy, Dual Scale in SCFM & in w.c.

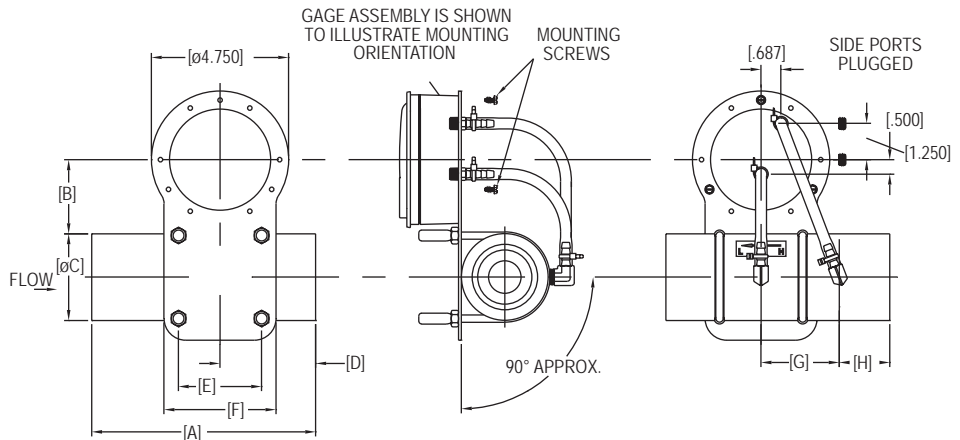

VFLO Option	Line Size	A	B	ØC	D	E	F	G	H	J	K
XXXX-XXVF1	1" FNPT	4.500	2.687	2	2.015	2.125	3.125	1.359	1.125	4.625	6.375
XXXX-XXVF2	1.5" FNPT	6	2.562	2.500	2.625	2.375	3.375	2	1.375	5.250	7.125
XXXX-XXVF3	2" FNPT	7.750	2.562	3	3.312	2.875	3.875	2.703	1.750	5.750	7.875
XXXX-XXVF4	3" FNPT	11	2.734	4	4.625	4	5.500	4	2.375	7	9.625
XXXX-XXVF5	4" FNPT	14.500	2.734	5.000	5.172	5.000	6.500	5.328	3.000	9.250	11.500

The Series VFLO Venturi Flowmeter with Magnehelic® Gage is fabricated from aluminum and has a gradual Venturi profile to reduce pressure losses through the meter. Flowmeter can be used in a vertical or horizontal position just by rotating the Magnehelic® gage. The Magnehelic® gage provides a large, clear and accurate display of your differential pressure reading. Each meter is calibrated at standard atmospheric conditions. The dual scale reads in SCFM and in w.c. The meter is supplied with easy to read reference charts for various flow conditions. It is available in line sizes from 1" to 4" and can handle vacuum and pressure applications.

### FEATURES/BENEFITS

- Gradual Venturi profile reduces pressure losses through meter helping to insure a more accurate measurement to meet measurement specifications
- Easy to read gage through undistorted plastic face permits viewing from far away
- Patented design provides quick response to pressure changes means no delay in assessing critical situations
- Durable and rugged housing and high-quality components combined provides long-service life and minimized down-time

### APPLICATIONS

- Filter monitoring
- Air velocity with Dwyer pitot tube
- Blower vacuum monitoring
- Fan pressure indication
- Duct, room or building pressures
- Clean room positive pressure indication

### Series 2000, Magnehelic® Differential Pressure Gage

To Create Venturi Model, add option from chart to end of 2000.

**Example:** 2000-10VF1 for 10 in w.c. & 20 SCFM of Air Scale with 1" Venturi Flow Tube

### ACCESSORIES

Model	Description
MVB-LM1	Mini brass ball valve with lever handle. 1/8" F X 1/8" MNPT
MVB-TM1	Mini brass valve with tee handle. 1/8" M X 1/8" FNPT
MVB-WM1	Mini brass ball valve with wedge handle. 1/8" M X 1/8" FNPT

### SPECIFICATIONS

**Service:** Air and non-combustible, compatible gases.  
**Wetted Materials:** Aluminum, silicone, acrylic, polycarbonate, high carbon steel, low carbon steel, brass, paper, acrylic paint, enamel paint, alkyd coating, nickel plate, zinc plate, hessel FC, 300 series stainless steel, PTFE, Loctite® AV sealant, commercial black rubber, neoprene, samarium cobalt, nickel alloy steel cover, beryllium copper.  
**Housing:** Die cast aluminum case and bezel, with acrylic cover. Exterior finish is coated gray to withstand 168 hour salt spray corrosion test.  
**Accuracy:** ±2.5% FS.

**Pressure Limits:** -20" Hg to 15 psig (-0.677 bar to 1.034 bar); MP option: 35 psig (2.41 bar). For applications with high cycle rate within gage total pressure rating, next higher rating is recommended.  
**Overpressure:** Relief plug opens at approximately 25 psig (1.72 kPa).  
**Temperature Limits:** 20 to 140°F (-6.67 to 60°C).  
**Size:** 4" (101.6 mm) diameter dial face.  
**Mounting Orientation:** Diaphragm in vertical position. Consult factory for other position orientations.  
**Process Connection:** Female NPT of nominal line size. (See chart).  
**Weight:** Gage only: 1 lb 2 oz (510 g), MP & HP 2 lb 2 oz (963 g); Venturi: see chart.

### OPTIONS

Option	Range	Line Size	Weight (Not Including Gage) lb (kg)
2000-10VF1	0 to 10 in w.c. & 0 to 20 SCFM air	1"	3 (1.36)
2000-20VF1	0 to 20 in w.c. & 0 to 30 SCFM air	1"	3 (1.36)
2000-40VF1	0 to 40 in w.c. & 0 to 40 SCFM air	1"	3 (1.36)
2000-10VF2	0 to 10 in w.c. & 0 to 50 SCFM air	1-1/2"	4.5 (2.04)
2000-20VF2	0 to 20 in w.c. & 0 to 70 SCFM air	1-1/2"	4.5 (2.04)
2000-40VF2	0 to 40 in w.c. & 0 to 100 SCFM air	1-1/2"	4.5 (2.04)
2000-10VF3	0 to 10 in w.c. & 0 to 85 SCFM air	2"	6 (2.72)
2000-20VF3	0 to 20 in w.c. & 0 to 120 SCFM air	2"	6 (2.72)
2000-40VF3	0 to 40 in w.c. & 0 to 160 SCFM air	2"	6 (2.72)
2000-10VF4	0 to 10 in w.c. & 0 to 200 SCFM air	3"	11 (4.99)
2000-20VF4	0 to 20 in w.c. & 0 to 290 SCFM air	3"	11 (4.99)
2000-40VF4	0 to 40 in w.c. & 0 to 395 SCFM air	3"	11 (4.99)
2000-10VF5	0 to 10 in w.c. & 0 to 350 SCFM air	4"	18 (8.16)
2000-20VF5	0 to 20 in w.c. & 0 to 500 SCFM air	4"	18 (8.16)
2000-40VF5	0 to 40 in w.c. & 0 to 675 SCFM air	4"	18 (8.16)

\*\*Venturi price must be added to Series 2000 Magnehelic® gage price

USA: California Proposition 65

⚠WARNING: Cancer and Reproductive Harm - www.P65Warnings.ca.gov

Loctite® is a registered trademark of Henkel Corporation

# IN-LINE FLOW SENSORS

Use with the Dwyer® Differential Pressure Gages or Transmitters

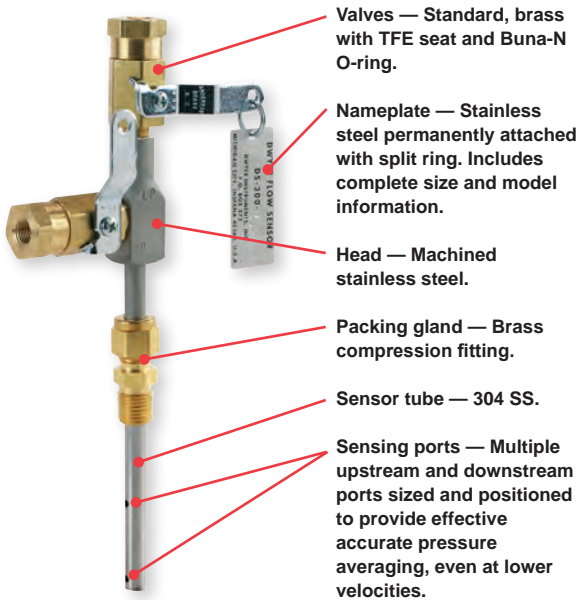

- Valves — Standard, brass with TFE seat and Buna-N O-ring.
- Nameplate — Stainless steel permanently attached with split ring. Includes complete size and model information.
- Head — Machined stainless steel.
- Packing gland — Brass compression fitting.
- Sensor tube — 304 SS.
- Sensing ports — Multiple upstream and downstream ports sized and positioned to provide effective accurate pressure averaging, even at lower velocities.

Series DS-300

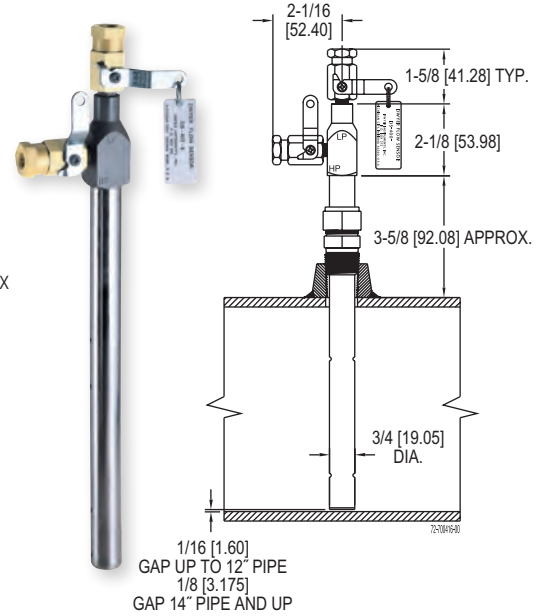
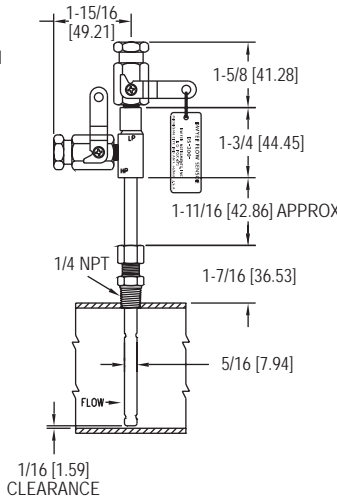

Large 3/4 inch diameter for extra strength in lengths to 24 inches

Series DS-400

The **Series DS In-Line Flow Sensors** are two Series of averaging Pitot tubes for compatible gases and liquids that provide accurate and convenient flow rate sensing, for schedule 40 pipe, when purchased with suitable differential pressure gage with appropriate range. The Series DS-300 Averaging Flow Sensors are designed to be inserted in the pipeline through a compression fitting and available for pipe sizes from 1 to 10" (2.5 to 25.4 cm). Accessories include adapters with 1/4" SAE 45° flared ends compatible with hoses supplied with the Model A-471 Portable Capsuhelic® Gage Kit. The Series DS-400 Averaging Flow Sensors are designed for insertion lengths up to 24" (61 cm) and include a pair of 1/8" NPT x 1/4" SAE 45° flared adapters which are compatible with hoses used in the Model A-471 Portable Capsuhelic® Gage Kit. The supplied solid brass mounting adapter has a 3/4" dia. compression fitting to lock in required insertion length and a 3/4" male NPT thread for mounting in a threaded branch connection (not included).

**FEATURES/BENEFITS**

- Multiple sensing point measurement and built-in averaging capability eliminates the need for "traversing" the flowing stream with single point velocity pressure measurement saving time
- Extremely reliable, proven technology, Pitot tubes, have been used in flow measurement for years
- All models include convenient and quick-acting quarter-turn ball valves to isolate the sensor for zeroing with 1/8" female NPT valve assembly process connections.
- Furnished with instrument shut-off valves on both pressure connections with 1/8" female NPT connections rated at 200 psig (13.7 bar) and 200°F (93.3°C)
- Where valves are not required, they can be omitted at reduced cost
- The Series DS-400 Averaging Flow Sensors are quality constructed from extra strong 3/4" dia. stainless steel to resist increased forces encountered at higher flow rates with both air and water
- Economical flow indication when used with appropriate differential pressure gage
- Rugged construction yields, non-clogging, stable design

**SPECIFICATIONS**

**Service:** Compatible gases or liquids.  
**Wetted Materials:** Sensor tube: 304 SS; Compression fitting: brass.  
**Temperature Limit:** 200°F (93.3°C).  
**Pressure Limit:** 200 psig (13.78 bar) at 200°F (93.3°C).  
**Pipe Sizes:** DS-300: 1 to 10" (2.5 to 25.4 cm); DS-400: 6 to 24" (15.2 to 61 cm).  
**Process Connections:** DS-300: 1/4" male NPT compression fitting included; DS-400: 3/4" male NPT compression fitting included.  
**Piping Connections:** DS-300: 1/8" female NPT; optional 1/8" female NPT x 1/4" SAE 45 flared adapter sold separately; DS-400: 1/8" female NPT with 1/8" female NPT x 1/4" SAE 45 flared adapters include.  
**Weights:** Consult factory.

**APPLICATIONS**

- Remediation
- Natural, flare, flue, stack gas
- Boiler feedwater
- Cooling water
- Superheated, saturated, or geothermal steam
- Combustion or compressed air
- Oil flow monitoring

# IN-LINE FLOW SENSORS

Use with the Dwyer® Differential Pressure Gages or Transmitters

## HOW TO ORDER

Merely determine the pipe size into which the flow sensor will be mounted and designate the size as a suffix to Model DS-300. For example, a flow sensor to be mounted in a 2" pipe would be a Model No. DS-300-2".

For non-critical water and air flow monitoring applications, the chart below can be utilized for ordering a stock Capsuhelic® differential pressure gage for use with the DS-300 flow sensor. Simply locate the maximum flow rate for the media being measured under the appropriate pipe size and read the Capsuhelic® gage range in inches of water column to the left. The DS-300 sensor is supplied with installation and operating instructions, Bulletin F-50. It also includes complete flow conversion information for the three media conditions shown in the chart below. This information enables the user to create a complete differential pressure to flow rate conversion table for the sensor and differential pressure gage employed. Both the Dwyer® Capsuhelic® gage and flow sensor feature excellent repeatability so, once the desired flow rate is determined, deviation from that flow in quantitative measure can be easily determined. You may wish to order the adjustable signal flag option for the Capsuhelic® gage to provide an easily identified reference point for the proper flow.

Capsuhelic® gages with special ranges and/or direct reading scales in appropriate flow units are available on special order for more critical applications. Customer supplied data for the full-scale flow (quantity and units) is required along with the differential pressure reading at that full flow figure. Prior to ordering a special Capsuhelic® differential pressure gage for flow read-out, we recommend you request Bulletin F-50 to obtain complete data on converting flow rates of various media to the sensor differential pressure output. With this bulletin and after making a few simple calculations, the exact range gage required can easily be determined.

MODEL CHART			
Model	Description	Model	Description
DS-300-1"	1" pipe size	DS-400-6"	6" pipe size
DS-300-1-1/4"	1-1/4" pipe size	DS-400-8"	8" pipe size
DS-300-1-1/2"	1-1/2" pipe size	DS-400-10"	10" pipe size
DS-300-2"	2" pipe size	DS-400-12"	12" pipe size
DS-300-2-1/2"	2-1/2" pipe size	DS-400-14"	14" pipe size
DS-300-3"	3" pipe size	DS-400-16"	16" pipe size
DS-300-4"	4" pipe size	DS-400-18"	18" pipe size
DS-300-6"	6" pipe size	DS-400-20"	20" pipe size
DS-300-8"	8" pipe size	DS-400-24"	24" pipe size
DS-300-10"	10" pipe size		

OPTIONS	
To order add suffix:	Description
-LV	DS-300 or DS-400 less valves

RANGE CHART											
Gage Range (in w.c.)	Media @ 70°F	Full Range Flows by Pipe Size (Approximate)									
		1"	1-1/4"	1-1/2"	2"	2-1/2"	3"	4"	6"	8"	10"
2	Water (GPM)	4.8	8.3	11.5	20.5	30	49	86	205	350	560
2	Air @ 14.7 PSIA (SCFM)	19.0	33.0	42.0	65.0	113	183	330	760	1340	2130
2	Air @ 100 PSIG (SCFM)	50.0	90.5	120.0	210.0	325	510	920	2050	3600	6000
5	Water (GPM)	7.7	14.0	18.0	34.0	47	78	138	320	560	890
5	Air @ 14.7 PSIA (SCFM)	30.0	51.0	66.0	118.0	178	289	510	1200	2150	3400
5	Air @ 100 PSIG (SCFM)	83.0	142.0	190.0	340.0	610	820	1600	3300	5700	10000
10	Water (GPM)	11.0	19.0	25.5	45.5	67	110	195	450	800	1260
10	Air @ 14.7 PSIA (SCFM)	41.0	72.0	93.0	163.0	250	410	725	1690	3040	4860
10	Air @ 100 PSIG (SCFM)	120.0	205.0	275.0	470.0	740	1100	2000	4600	8100	15000
25	Water (GPM)	18.0	32.0	40.5	72.0	108	173	310	720	1250	2000
25	Air @ 14.7 PSIA (SCFM)	63.0	112.0	155.0	255.0	390	640	1130	2630	4860	7700
25	Air @ 100 PSIG (SCFM)	185.0	325.0	430.0	760.0	1200	1800	3300	7200	13000	22000
50	Water (GPM)	25.0	44.0	57.5	100.0	152	247	435	1000	1800	
50	Air @ 14.7 PSIA (SCFM)	90.0	161.0	205.0	360.0	560	900	1600	3700	6400	
50	Air @ 100 PSIG (SCFM)	260.0	460.0	620.0	1050.0	1700	2600	4600	10000	18500	
100	Water (GPM)	36.5	62.0	82.0	142.0	220	350	620	1500		
100	Air @ 14.7 PSIA (SCFM)	135.0	230.0	300.0	505.0	800	1290	2290	5000		
100	Air @ 100 PSIG (SCFM)	370.0	660.0	870.0	1500.0	2300	3600	6500	15000		

ACCESSORIES	
Model	Description
A-160	Threaded branch connection, 3/8" NPT, forged steel, 3000 psi
A-161	Brass bushing, 1/4" x 3/8"
A-471	Portable Kit. For portable operation, the A-471 Capsuhelic® Portable Gage Kit is available complete with tough polypropylene carrying case, mounting bracket, 3-way manifold valve, two 10' high pressure hoses, and all necessary fittings. ①
631B	Capsuhelic® Wet/Wet Differential Pressure Transmitter. Low pressure transmitter for use with DS-300/400 flow sensors. Use Series 631B Capsuhelic® Wet/Wet Differential Pressure Transmitter. ②



Capsuhelic® gage shown installed in A-471 portable kit



Series 631B

USA: California Proposition 65  
⚠WARNING: Cancer and Reproductive Harm - www.P65Warnings.ca.gov

① See page 31 (Series 4000)  
② See page 81 (Series 631B)

**Dwyer**

SERIES OP, PE &amp; TE

**ORIFICE PLATE FLOWMETERS**

PVC or PTFE, Liquid and Gas use Options

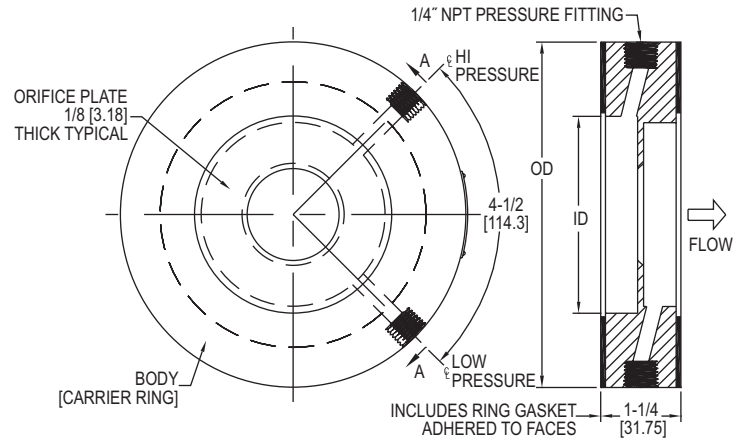

The **Series OP Orifice Plate Flowmeters** are a complete flow metering package. They incorporate a stainless steel orifice plate with a unique holder or carrier ring containing metering taps and integral gaskets. The Series OP is available in line sizes from 1/2" to 24" and can be used with compatible liquids and gases.

**FEATURES/BENEFITS**

- Mounted with standard flanges with no need of specialty flanges
- Reduced installation costs with simple installation by slipping the unit between standard flanges
- Easy access with corner type metering taps
- Long operation life with corrosion free material
- Stainless steel wetted parts assures long term reliability and accuracy
- Proven through a wide range of applications for energy efficiency

**APPLICATIONS**

- Fluid flow rates in building water lines
- Boiler feedwater
- Cooling water
- Combustion or compressed air
- Steam flow

The **SERIES PE & TE Orifice Plate Flowmeters** are two series of plastic orifice plate flow metering packages incorporating a unique holder or carrier ring containing metering taps and integral gaskets. They can be used in place of other primary differential products for efficiency and cost effectiveness.

The Series PE orifice plate flowmeter is of PVC construction and is available in line sizes from 1/2" to 24". This series can be used for air and most gases and meets or exceeds ASME, AGA & ISO standards.

The Series TE orifice plate flowmeter is of PTFE construction and is available in line sizes from 1/2" to 24". This Series can be used with gases, liquids, corrosive and high temperature fluids.

**FEATURES/BENEFITS**

- Mounted with standard flanges with no need of specialty flanges
- Reduced installation costs with simple installation by slipping the unit between standard flanges
- Easy access with corner type metering taps
- Long operation life with corrosion free material
- Proven through a wide range of applications for energy efficiency
- PTFE construction yields excellent chemical and weather resistance
- TE models are flame retardant without factory gaskets
- Low friction leading to minimum wear and long operation life

**APPLICATIONS**

- Fluid flow rates in building water lines
- Boiler feedwater
- Cooling water
- Combustion or compressed air
- Steam flow

**SPECIFICATIONS**

**Service:** OP & TE: Compatible liquids and gases; PE: Clean air and compatible gases.

**Wetted Material:** OP: 304 SS, Buna-N gaskets; PE: Gray PVC, Buna-N gaskets; TE: PTFE, Buna-N gaskets.

**Accuracy:** 0.6% FS. (Beta = .2-.6)  $\pm 0.7\%$  for Beta greater than .6.

**Temperature Limits:** OP: -50 to 200°F (-45 to 93°C); PE: 140°F (60°C) max; TE: -40 to 200°F (-40 to 93.3°C).

**Pressure Limits:** OP: Limited only by pipe and flange rating restrictions.

**Head Loss:** 1-Beta ratio<sup>2</sup> eg: 1-0.72 = 1-0.49 = 51% of the d.p.

**Line Sizes:** 1/2" to 24".

**Process Connection:** 1/4" female NPT.

**Installation:** Standard flange. OP: Any rating (orifice flanges not required); PE & TE: 125#/150# rating.

**Pipe Requirements:** General requirements 10 diameter upstream and 5 diameter downstream of orifice plate.

**Weight:** Varies with line size. See chart.



# ORIFICE PLATE FLOWMETERS

PVC or PTFE, Liquid and Gas use Options

## SERIES OP ORIFICE PLATE FLOWMETER – CAPACITY STRUCTURE

- Material 304/304 L, Gaskets Buna-N
- Based on 70°F, 14.7 psia (base conditions)
- Beta value based on std sch pipe I.D.
- 1.25" overall thickness
- Orifice plate thickness is 0.125"

## SERIES PE ORIFICE PLATE FLOWMETER – AIR CAPACITY STRUCTURE

- Material PVC, Gaskets Buna-N
- Based on 70°F, 14.7 psia (base conditions)
- Beta value based on std sch pipe I.D.
- 1.25" overall thickness
- Orifice plate thickness is 0.125"

## SERIES TE ORIFICE PLATE FLOWMETER – CAPACITY STRUCTURE

- Material PTFE, Gaskets Buna-N
- Based on 70°F, 14.7 psia (base conditions)
- Beta value based on std sch pipe I.D.
- 1.25" overall thickness
- Orifice plate thickness is 0.250"

MODEL CHART														
OP Model	OP Weight (lb)	PE Model	PE Weight (lb)	TE Model	TE Weight (lb)	Line Size	Bore	Beta	Water Capacity		Air Capacity - Flow in SCFM			
									in d.p. w.c.	Flow in GPM	in d.p. w.c.	at 14.7 psia (0 psig)	at 20 psig	at 100 psig
OP-A-1	1.00	PE-A-1	1.00	TE-A-1	1.00	1/2"	0.200"	0.32	20	0.62	20	2.35	3.63	6.61
OP-A-2	1.00	PE-A-2	1.00	TE-A-2	1.00	1/2"	0.310"	0.50	100	3.44	100	12.21	19.58	36.37
OP-A-3	1.00	PE-A-3	1.00	TE-A-3	1.00	1/2"	0.430"	0.69	320	13.00	200	32.77	56.15	107.47
OP-B-1	1.00	PE-B-1	1.00	TE-B-1	1.00	3/4"	0.250"	0.30	20	0.97	20	3.65	5.66	10.3
OP-B-2	1.00	PE-B-2	1.00	TE-B-2	1.00	3/4"	0.400"	0.49	100	5.69	100	20.21	32.44	60.26
OP-B-3	1.00	PE-B-3	1.00	TE-B-3	1.00	3/4"	0.580"	0.70	320	23.82	200	59.92	102.91	197.2
OP-C-1	2.00	PE-C-1	1.00	TE-C-1	1.00	1"	0.300"	0.29	20	1.38	20	5.24	8.11	14.8
OP-C-2	2.00	PE-C-2	1.00	TE-C-2	1.00	1"	0.520"	0.49	100	9.63	100	34.2	54.92	102.09
OP-C-3	2.00	PE-C-3	1.00	TE-C-3	1.00	1"	0.720"	0.69	320	36.15	200	91.28	156.51	300
OP-D-1	2.00	PE-D-1	1.00	TE-D-1	1.00	1.25"	0.400"	0.29	20	2.46	20	9.31	14.41	26.3
OP-D-2	2.00	PE-D-2	1.00	TE-D-2	1.00	1.25"	0.700"	0.51	100	17.48	100	62.09	99.75	185.5
OP-D-3	2.00	PE-D-3	1.00	TE-D-3	1.00	1.25"	1.00"	0.72	320	71.77	200	180	309.97	595.2
OP-E-1	2.00	PE-E-1	2.00	TE-E-1	2.00	1.5"	0.500"	0.31	20	3.85	20	14.57	22.55	41.16
OP-E-2	2.00	PE-E-2	2.00	TE-E-2	2.00	1.5"	0.800"	0.50	100	22.73	100	80.82	129.68	241.5
OP-E-3	2.00	PE-E-3	2.00	TE-E-3	2.00	1.5"	1.100"	0.68	320	83.95	200	212.18	363.93	697.39
OP-F-1	3.00	PE-F-1	2.00	TE-F-1	2.00	2"	0.600"	0.29	20	5.52	20	20.92	32.38	59.13
OP-F-2	3.00	PE-F-2	2.00	TE-F-2	2.00	2"	1.000"	0.48	100	35.34	100	125.74	202.03	375.8
OP-F-3	3.00	PE-F-3	2.00	TE-F-3	2.00	2"	1.450"	0.70	320	147.74	200	372.09	639.87	1227.63
OP-G-1	4.00	PE-G-1	2.00	TE-G-1	2.00	2.5"	0.750"	0.30	20	8.63	20	32.71	50.64	92.48
OP-G-2	4.00	PE-G-2	2.00	TE-G-2	2.00	2.5"	1.250"	0.50	100	55.54	100	197.54	317.58	590.91
OP-G-3	4.00	PE-G-3	2.00	TE-G-3	2.00	2.5"	1.750"	0.70	320	216.30	200	543.99	936.56	1798.86
OP-H-1	5.00	PE-H-1	2.00	TE-H-1	2.00	3"	0.920"	0.30	20	12.97	20	49.17	76.13	139.06
OP-H-2	5.00	PE-H-2	2.00	TE-H-2	2.00	3"	1.500"	0.49	100	79.94	100	282.9	454.77	846.21
OP-H-3	5.00	PE-H-3	2.00	TE-H-3	2.00	3"	2.150"	0.70	320	324.16	200	816.7	1404.95	2696.28
OP-J-1	7.00	PE-J-1	3.00	TE-J-1	3.00	4"	1.200"	0.30	20	22.03	20	83.58	129.44	236.48
OP-J-2	7.00	PE-J-2	3.00	TE-J-2	3.00	4"	2.000"	0.50	100	141.51	100	503.76	810.06	1507.64
OP-J-3	7.00	PE-J-3	3.00	TE-J-3	3.00	4"	2.800"	0.70	320	547.11	200	1380.03	2373.02	4553.68
OP-K-1	8.00	PE-K-1	3.00	TE-K-1	4.00	5"	1.500"	0.30	20	34.39	20	130.48	202.11	369.29
OP-K-2	8.00	PE-K-2	3.00	TE-K-2	4.00	5"	2.500"	0.50	100	220.80	100	786.23	1264.42	2353.51
OP-K-3	8.00	PE-K-3	3.00	TE-K-3	4.00	5"	3.500"	0.69	320	853.09	200	2152.83	3701.57	7103.22
OP-L-1	10.00	PE-L-1	4.00	TE-L-1	4.00	6"	1.800"	0.30	20	49.46	20	187.86	291	531.75
OP-L-2	10.00	PE-L-2	4.00	TE-L-2	4.00	6"	3.000"	0.49	100	317.74	100	1331.63	1820.05	3387.93
OP-L-3	10.00	PE-L-3	4.00	TE-L-3	4.00	6"	4.200"	0.69	320	1226.98	200	3097.20	5325.20	10219.28
OP-M-1	14.00	PE-M-1	5.00	TE-M-1	6.00	8"	2.400"	0.30	20	87.95	20	333.87	517.25	945.28
OP-M-2	14.00	PE-M-2	5.00	TE-M-2	6.00	8"	4.000"	0.50	100	565.77	100	2014.95	3241.45	6034.85
OP-M-3	14.00	PE-M-3	5.00	TE-M-3	6.00	8"	5.600"	0.70	320	2195.86	200	5532.00	9525.43	18290.00
OP-N-1	20.00	PE-N-1	6.00	TE-N-1	8.00	10"	3.000"	0.30	20	137.35	20	521.58	808	1476.77
OP-N-2	20.00	PE-N-2	6.00	TE-N-2	8.00	10"	5.000"	0.50	100	883.04	100	3145.50	5060.38	9421.74
OP-N-3	20.00	PE-N-3	6.00	TE-N-3	8.00	10"	7.000"	0.70	320	3421.26	200	8626.42	14846.80	28506.17
OP-O-1	30.00	PE-O-1	7.00	TE-O-1	10.00	12"	3.600"	0.30	20	197.73	20	750.9	1163.44	2126.47
OP-O-2	30.00	PE-O-2	7.00	TE-O-2	10.00	12"	6.000"	0.50	100	1271.62	100	4530	7288.16	13570.33
OP-O-3	30.00	PE-O-3	7.00	TE-O-3	10.00	12"	8.400"	0.70	320	4930.86	200	12430.00	21397.00	41089.02
OP-P-1	40.00	PE-P-1	9.00	TE-P-1	15.00	14"	4.000"	0.30	20	244.14	20	927.14	1436.59	2625.81
OP-P-2	40.00	PE-P-2	9.00	TE-P-2	15.00	14"	6.600"	0.50	100	1537.49	100	6477.67	8812.87	16409.42
OP-P-3	40.00	PE-P-3	9.00	TE-P-3	15.00	14"	9.300"	0.70	320	6052.57	200	15251.50	28262.66	50427.78
OP-Q-1	48.00	PE-Q-1	10.00	TE-Q-1	18.00	16"	4.500"	0.30	20	308.76	20	1172.63	1817.05	3321.32
OP-Q-2	48.00	PE-Q-2	10.00	TE-Q-2	18.00	16"	7.600"	0.50	100	2038.95	100	7264.58	11688.26	21764.08
OP-Q-3	48.00	PE-Q-3	10.00	TE-Q-3	18.00	16"	10.700"	0.70	320	8007.74	200	20179.85	34749.32	66737.64

Note: Differential pressure values should be less than 50% of the inlet absolute pressure.



SERIES DTFW, DTFO & DTFA

# VARIABLE-AREA FLOWMETERS

In-Line Mounting, Gas, Liquids and Oils



DTFW



DTFO



DTFA

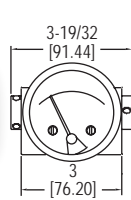

1/4" NPT connection

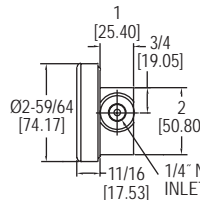

1/2" NPT connection

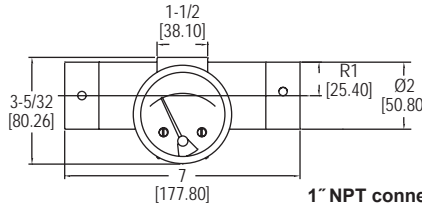

1" NPT connection

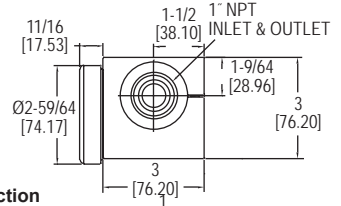

1/2" NPT process connection

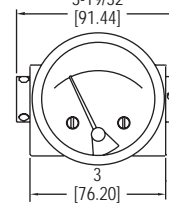
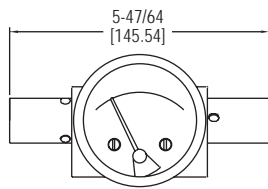

1/4" NPT connection

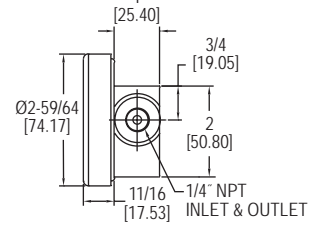

The **Series DTFW & DTFO Variable-Area Flowmeters** for Liquids and Oils measure water or oil flow rates with  $\pm 2\%$  of full-scale accuracy at a competitive price. Available in 1/4", 1/2" and 1" connections for a wide variety of applications and comes calibrated for horizontal in line mounting.

The **Series DTFA Variable-Area Flowmeters** for Gases measures gas flow rates with  $\pm 5\%$  of full-scale accuracy at an affordable price. Available in either 1/4" or 1/2" NPT connections and comes pre-calibrated for horizontal in-line mounting.

**FEATURES/BENEFITS**

- Durable metal construction ensures great reliability and the strength to withstand system pressures of up to 3000 psig (200 bar).
- Shatter proof construction, unlike glass tube variable area flowmeters, yields long operation life
- Perform precisely in high temperature, high vibration, shock-prone environments

**APPLICATIONS**

- Monitoring pressure drop across filters or strainers
- Flow scale based on differential pressure
- Liquid level given pressure differential between bottom and top of tank
- Hydraulic equipment
- Oil & gas equipment
- Heat exchangers
- Backflow prevention

**SPECIFICATIONS**

**Service:** DTFW: Compatible liquids; DTFO: Compatible oils; DTFA: Compatible gases.  
**Wetted Materials:** Body: 316 SS, brass or aluminum; Spring: 302 SS or PTFE-coated; Range spring: 302 SS; Magnet: PTFE-coated; Metering cone: Acetal or PTFE; Seals: Buna.  
**Temperature Limits:** -40 to 200°F (-40 to 93°C).  
**Pressure Limit:** DTFW-3S: 1500 psig (100 bar); All other DTFW models: 3000 psig (200 bar); DTFO-1B and DTFO-2B: 3000 psig (200 bar); DTFO-3S: 1500 psig (100 bar); DTFA: 3000 psig (200 bar).

**Accuracy:** Liquid/oil calibration:  $\pm 2\%$  FS; Air calibration:  $\pm 5\%$  FS.  
**Repeatability:**  $\pm 1\%$  FS.  
**Size:** Diameter dial face 2.5" (63.5 mm).  
**Process Connection:** See model chart.  
**Weight:** DTFW-1B and 1S: 3 lb (1.36 kg); DTFW-2B and 2S: 5 lb (2.27 kg); DTFW-3S: 10 lb (4.54 kg); DTFO-1B: 3 lb (1.36 kg); DTFO-2B: 5 lb (2.27 kg); DTFO-3S: 10 lb (4.54 kg); DTFA-1A: 3 lb (1.36 kg); DTFA-2A: 5 lb (2.27 kg).

**MODEL CHART**

Model	Range, SCFM	Body	Connection
DTFA-1A-10A	1.5 to 10	Aluminum	1/4" NPT
DTFA-1A-15A	2.0 to 15	Aluminum	1/4" NPT
DTFA-1A-20A	3.0 to 20	Aluminum	1/4" NPT
DTFA-1A-25A	3.0 to 25	Aluminum	1/4" NPT
DTFA-2A-30A	3.0 to 30	Aluminum	1/2" NPT
DTFA-2A-40A	4.0 to 40	Aluminum	1/2" NPT
DTFA-2A-50A	4.0 to 50	Aluminum	1/2" NPT
DTFA-2A-75A	5.0 to 75	Aluminum	1/2" NPT
DTFA-2A-100A	10.0 to 100	Aluminum	1/2" NPT

**MODEL CHART**

Model	Range GPM Water	Connection NPT	Body	Metering Cone	Model	Range GPM Water	Connection NPT	Body	Metering Cone
DTFW-1B-1W	0 to 1	1/4"	Brass	Acetal	DTFW-2B-8W	0 to 8	1/2"	Brass	Acetal
DTFW-1B-2W	0 to 2	1/4"	Brass	Acetal	DTFW-2B-10W	0 to 10	1/2"	Brass	Acetal
DTFW-1B-3W	0 to 3	1/4"	Brass	Acetal	DTFW-2S-1W	0 to 1	1/2"	SS	Acetal
DTFW-1B-4W	0 to 4	1/4"	Brass	Acetal	DTFW-2S-2W	0 to 2	1/2"	SS	Acetal
DTFW-1B-5W	0 to 5	1/4"	Brass	Acetal	DTFW-2S-3W	0 to 3	1/2"	SS	Acetal
DTFW-1S-1W	0 to 1	1/4"	SS	Acetal	DTFW-2S-4W	0 to 4	1/2"	SS	Acetal
DTFW-1S-2W	0 to 2	1/4"	SS	Acetal	DTFW-2S-5W	0 to 5	1/2"	SS	Acetal
DTFW-1S-3W	0 to 3	1/4"	SS	Acetal	DTFW-2S-8W	0 to 8	1/2"	SS	Acetal
DTFW-1S-4W	0 to 4	1/4"	SS	Acetal	DTFW-2S-10W	0 to 10	1/2"	SS	Acetal
DTFW-1S-5W	0 to 5	1/4"	SS	Acetal	DTFW-3S-10W	0 to 10	1"	SS	PTFE
DTFW-2B-1W	0 to 1	1/2"	Brass	Acetal	DTFW-3S-15W	0 to 15	1"	SS	PTFE
DTFW-2B-2W	0 to 2	1/2"	Brass	Acetal	DTFW-3S-20W	0 to 20	1"	SS	PTFE
DTFW-2B-3W	0 to 3	1/2"	Brass	Acetal	DTFW-3S-25W	0 to 25	1"	SS	PTFE
DTFW-2B-4W	0 to 4	1/2"	Brass	Acetal	DTFW-3S-30W	0 to 30	1"	SS	PTFE
DTFW-2B-5W	0 to 5	1/2"	Brass	Acetal					

**Note:** For oil compatible models, change all W's to O's in model number. **Example:** DTFO-1B-1O  
**Note:** Not available in 1/4" or 1/2" SS.

USA: California Proposition 65  
 ⚠WARNING: Cancer and Reproductive Harm - www.P65Warnings.ca.gov

# SIGHT WINDOW

Shows Level or Contents of Tanks, Pipelines; Tempered, Replaceable Glass Window



REPLACEABLE WINDOW!

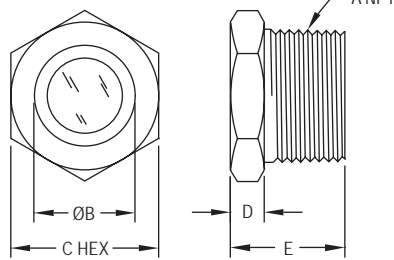

Model	Dimensions — Inches (mm)				
	A	B	C	D	E
SFI-500-3/4	3/4	3/4 [19]	1-3/8 [35]	45/64 [18]	1-3/8 [35]
SFI-500-1	1	15/16 [24]	1-3/8 [35]	45/64 [18]	1-3/8 [35]
SFI-500-1-1/4	1-1/4	1-1/4 [32]	2-1/8 [54]	27/32 [22]	1-9/16 [40]
SFI-500-1-1/2	1-1/2	1-27/64 [37]	2-1/8 [54]	27/32 [22]	1-9/16 [40]
SFI-500-2	2	1-1/4 [32]	2-1/2 [64]	15/32 [12]	1-21/32 [42]

The **Series 500 Sight Window** is a Series of standard tempered glass with brass body sight windows which display level or contents of tanks or pipelines. In addition to the standard brass body, the Series 500 Sight windows are also available in carbon steel or 316 SS.

### FEATURES/BENEFITS

- Tough, tempered glass window resists chemical attack and abrasion
- Seamless, replaceable gasket assures perfect seal
- Field replaceable glass window
- Range of wetted materials to suit a wide range of chemical compatibility

### APPLICATIONS

- Hydraulic tanks
- Pressure vessels
- Coolant tanks
- Hydraulic lines
- Oil reservoirs

### SPECIFICATIONS

**Service:** Compatible gases and liquids.  
**Wetted Materials:** Window: Tempered glass; Body: Brass, carbon steel, or 316 SS; Gasket: Buna-N on brass and carbon steel body, PTFE on 316 SS body.  
**Temperature Limit:** 200°F (93°C).  
**Pressure Limit:** 125 psig (8.6 bar).  
**Connections:** 3/4" to 2" male NPT.  
**Agency Approvals:** Meets the technical requirements of EU Directive 2011/65/EU (RoHS II).

### MODEL CHART

316 SS Model	Brass Model	Carbon Steel Model
SFI-500SS-3/4	SFI-500B-3/4	SFI-500CS-3/4
SFI-500SS-1	SFI-500B-1	SFI-500CS-1
SFI-500SS-1-1/4	SFI-500B-1-1/4	SFI-500CS-1-1/4
SFI-500SS-1-1/2	SFI-500B-1-1/2	SFI-500CS-1-1/2
SFI-500SS-2	SFI-500B-2	SFI-500CS-2

USA: California Proposition 65  
 ⚠️WARNING: Cancer and Reproductive Harm - [www.P65Warnings.ca.gov](http://www.P65Warnings.ca.gov)

# SIGHT WINDOW

Shows Level or Contents of Tanks, Pipelines; Fused Glass and Steel Construction

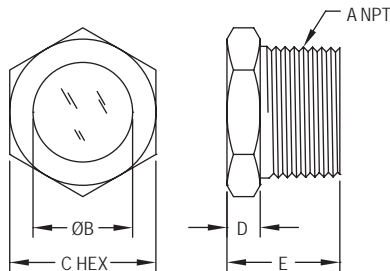
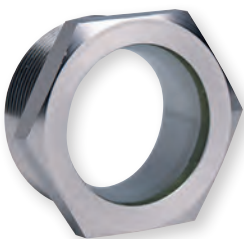

Model	Dimensions — Inches (mm)				
	A	B	C	D	E
SFI-550-1/4	1/4	11/32 [8.73]	5/8 [15.95]	3/16 [4.76]	5/8 [15.95]
SFI-550-3/8	3/8	7/16 [11.11]	3/4 [19.05]	7/32 [5.56]	23/32 [18.26]
SFI-550-1/2	1/2	9/16 [14.29]	15/16 [23.81]	7/32 [5.56]	25/32 [19.84]
SFI-550-3/4	3/4	3/4 [19.05]	1-1/16 [26.99]	5/16 [7.94]	15/16 [23.81]
SFI-550-1	1	15/16 [23.81]	1-3/8 [34.93]	5/16 [7.94]	1-1/16 [26.99]
SFI-550-1-1/4	1-1/4	1-3/16 [30.18]	1-3/4 [44.45]	13/32 [10.32]	1-7/32 [30.96]
SFI-550-1-1/2	1-1/2	1-7/16 [36.53]	2 [50.80]	13/32 [10.32]	1-7/32 [30.96]
SFI-550-2	2	1-7/8 [47.63]	2-1/2 [63.50]	13/32 [10.32]	1-9/32 [32.54]

The **Series 550 Sight Window** is a range of glass with plated steel body sight windows which display level or contents of tanks or pipelines. Connections are standard NPT in sizes ranging from 1/4 to 2".

### FEATURES/BENEFITS

- Glass to metal bond for utmost reliability
- Plated steel bodies have convenient hex wrench surfaces for easy installation
- Windows are clear, ripple free, and flush with the front face, with no recess on which dirt might collect

### APPLICATIONS

- Hydraulic tanks
- Pressure vessels
- Coolant tanks
- Hydraulic lines
- Oil reservoirs

### SPECIFICATIONS

**Service:** Compatible gases and liquids.  
**Wetted Materials:** Window: Glass; Body: Plated steel.  
**Temperature Limit:** 200°F (93°C).  
**Pressure Limit:** 125 psig (8.6 bar).  
**Connections:** 1/4" to 2" male NPT.

### MODEL CHART

Model	Model
SFI-550-1/4	SFI-550-1
SFI-550-3/8	SFI-550-1-1/4
SFI-550-1/2	SFI-550-1-1/2
SFI-550-3/4	SFI-550-2



SERIES SFI-100, SFI-300, SFI-300F, SFI-400 & SFI-700 | W. E. ANDERSON™ BY DWYER

# MIDWEST SIGHT FLOW INDICATORS

## Inexpensive Protection for Expensive Equipment and Systems



The **Series SFI Midwest Sight Flow Indicator** is a Series of sight indicators which display flow or contents of pipelines. Available in window viewing style in the SFI-100 and SFI-300 Series and tube viewing style in the SFI-400 and SFI-700 Series with connection choices of female NPT, BSPP or BSPT threaded and flanged.

**Series SFI-100 & SFI-300 Midwest Sight Flow Indicator** offers threaded process connections, viewing windows, and bodies of brass or 316 SS. The SFI-100 type has a single window with a rotating impeller, the 300 type has a double window with a rotating impeller, the SFI-350 type has a double window with no moving indicator, and the SFI-360 type has a double window with a flapper.

**Series SFI-300F Midwest Sight Flow Indicator** offers ANSI flange process connections, double viewing windows, and bodies of carbon steel or 316 SS. The SFI-350F type has a double window with no moving indicator and the SFI-360F type has a double window with a flapper.

**Series SFI-400 Midwest Sight Flow Indicator** offers threaded or ANSI flanged process connections, tube style viewing, and bodies of cast iron or 316 SS.

**Series SFI-700 Midwest Sight Flow Indicator** offers threaded process connections, tube style viewing, and bodies of brass or 316 SS.

### FEATURES/BENEFITS

- Manufactured of quality materials and safety tested to assure long, dependable service at economical prices
- All Series SFI-100, SFI-300 and SFI-300F feature a removable window for easy service and replacement of wearing parts
- The Series SFI-400 features glass tube construction offering easy flow viewing from any angle
- Series SFI-700 offers an easy to see bright red Acetal rotating impeller that is easy to view from any angle with the glass tube construction
- Maintenance is simple for the Series SFI-700 with internal wipers which restore full 360° visibility by simply rotating the glass tube without disrupting the flow

### APPLICATIONS

- Hydraulic tanks
- Pressure vessels
- Coolant tanks
- Hydraulic lines
- Oil reservoirs

### MODEL CHART

Model	Description
SFI-100	Single window with impeller
SFI-300	Double window with impeller
SFI-350	Double window with no indicator
SFI-360	Double window with flapper
SFI-400	Tube type with no indicator
SFI-700	Tube type with impeller and internal wipers to clean glass tube

++ USA: California Proposition 65  
 ⚠WARNING: Cancer and Reproductive Harm  
 - www.P65Warnings.ca.gov

### SPECIFICATIONS

#### SFI-100 & SFI-300 SPECIFICATIONS

**Service:** Compatible gases and liquids.  
**Wetted Materials:** Window: Tempered glass; Body: Bronze or 316 SS; Gasket: Buna-N, fluoroelastomer or PTFE; Indicator: ABS or 316 SS impeller (100 and 300), 304 SS or 316 SS flapper (360).

**Temperature Limit:** 200°F (93°C); 120°F (48°C) on W2 option; 170°F (77°C) on I1 option.

**Pressure Limit:** 125 psig (8.62 bar), 150 psig (10.34 bar) on "MP" models.

**Connections:** Threaded.

**Mounting Orientation:** Horizontal or vertical; 360: Horizontal only.

#### SFI-300F SPECIFICATIONS

**Service:** Compatible gases and liquids.  
**Wetted Materials:** Window: Tempered glass; Body: Carbon steel or 316 SS; Gasket: Buna-N, fluoroelastomer or PTFE; Indicator: 316 SS flapper (360).

**Temperature Limit:** 200°F (93°C).

**Pressure Limit:** 150 psig (10.34 bar).

**Connections:** Flanged.

**Mounting Orientation:** Horizontal or vertical; 360: Horizontal only.

#### SFI-400 SPECIFICATIONS

**Service:** Compatible gases and liquids.  
**Wetted Materials:** Tube: Borosilicate; Body: Cast iron or 316 SS; Gasket: PTFE.

**Temperature Limit:** 200°F (93°C).

**Pressure Limit:** 50 psig (3.45 bar).

**Connections:** Threaded or flanged.

#### SFI-700 SPECIFICATIONS

**Service:** Compatible gases and liquids.

**Wetted Materials:** Tube: Tempered borosilicate; Body: Brass or 316 SS; Gasket: Fluoroelastomer; Indicator: Acetal.

**Temperature Limit:** 212°F (100°C).

**Pressure Limit:** 230 psig (15.86 bar).

**Connections:** Threaded.

### DIMENSIONS AND WEIGHT

Model	Body Size	Length	Depth	Height	Flange Diameter	Viewing Area Diameter	Weight lb (kg)
SFI-100	1/4, 3/8	3.000 (76)	1.813 (46)	2.125 (54)	-	-	1.1 (0.5)
	1/2, 3/4	4.000 (102)	2.250 (57)	2.563 (65)	-	-	1.5 (0.7)
	1, 1-1/4	4.375 (111)	2.563 (65)	2.625 (67)	-	-	2.7 (1.2)
	1-1/2, 2	5.688 (144)	3.250 (83)	3.625 (83)	-	-	5.5 (2.5)
SFI-300	1/4, 3/8	3.063 (78)	2.250 (57)	2.125 (54)	-	-	1.7 (0.8)
	1/2, 3/4	4.063 (103)	2.750 (70)	2.563 (65)	-	-	2.6 (1.2)
	1, 1-1/4	4.375 (111)	3.125 (79)	2.563 (65)	-	-	3.0 (1.4)
	1-1/2, 2	5.500 (140)	3.688 (93)	4.063 (103)	-	-	7.0 (3.2)
SFI-700	1/4, 3/8	2.750 (70)	-	1.500 (38)	-	-	0.9 (0.4)
	1/2, 3/4	3.688 (94)	-	2.250 (57)	-	-	2.4 (1.1)
	1, 1-1/4, 1-1/2	4.875 (124)	-	2.750 (70)	-	-	5.1 (2.3)
					(across flats)		
SFI-400	1/2	4.500 (144)	-	-	3.500 (89)	1.500 (38)	3.8 (1.7)
	3/4	5.125 (130)	-	-	3.875 (98)	1.750 (44)	4.8 (2.2)
	1	5.625 (143)	-	-	4.250 (108)	2.000 (51)	6.2 (2.8)
	1-1/4	5.750 (146)	-	-	4.625 (117)	2.000 (51)	7.6 (3.5)
	1-1/2	5.875 (149)	-	-	5.000 (127)	2.500 (64)	8.7 (4.0)
	2	6.125 (156)	-	-	6.000 (152)	3.000 (76)	13 (6.0)
	3	6.250 (159)	-	-	7.500 (191)	4.000 (102)	17 (7.7)
	4	6.250 (159)	-	-	9.000 (229)	5.000 (127)	25 (11.0)
SFI-400F	1	5.000 (127)	-	-	4.250 (108)	2.000 (51)	7 (3.2)
	1-1/4	5.125 (130)	-	-	4.625 (117)	2.000 (51)	8 (3.6)
	1-1/2	5.250 (133)	-	-	5.000 (127)	2.500 (64)	12 (5.5)
	2	5.370 (137)	-	-	6.000 (152)	3.000 (76)	14 (6.4)
	3	5.750 (146)	-	-	7.500 (191)	4.000 (102)	23 (10.4)
4	5.750 (146)	-	-	9.000 (229)	5.000 (127)	31 (14.1)	
SFI-300F	1-1/2	6.375 (162)	-	-	5.000 (127)	2.313 (58)	12 (5.5)
	2	6.500 (165)	-	-	6.000 (152)	2.313 (58)	16 (7.5)
	3	8.875 (225)	-	-	7.500 (191)	3.000 (76)	38 (17)
	4	10.250 (260)	-	-	9.000 (229)	4.000 (102)	56 (25)
	6	12.500 (318)	-	-	11.000 (279)	6.000 (152)	120 (55)

Dimensions are in inches (mm)





# MIDWEST SIGHT FLOW INDICATORS

## Inexpensive Protection for Expensive Equipment and Systems

MODEL CHART						
SFI-100 & SFI-300 - WINDOW STYLE WITH THREADED CONNECTIONS						
Example	SFI	-300	SS	-2	-G2	SFI-300SS-2-G2
Model Designator	SFI					Sight flow indicator
Body Style		100 300 350 360				Single window, bronze body, ABS impeller Double window, bronze body, ABS impeller Double window, bronze body, no moving indicator Double window, bronze body, 304 SS flapper
Body Options			SS MP			316 SS body option for 300, 350, 360 150 psig maximum pressure option, includes fluoroelastomer gaskets
Body Size				1/4 3/8 1/2 3/4 1 1-1/4 1-1/2 2		1/4 inch connection size 3/8 inch connection size 1/2 inch connection size 3/4 inch connection size 1 inch connection size 1-1/4 inch connection size 1-1/2 inch connection size 2 inch connection size
Options					W2 G1 G2 S2 S3 I1 I2 I3 F1 BSPT BSPP	Plexiglass window PTFE gasket Fluoroelastomer gasket 316 SS shaft (not on 350 model) Monel shaft (not on 350 model) ABS impeller with bronze bushing (not on 350, 360) 316 SS impeller (not on 350, 360) No impeller (100 only) 316 SS flapper (360 only) BSPT threads BSPP threads
<b>Note:</b> Maximum flow on impeller models: 5 FPS with liquids, 5000 FPM with gases.						

MODEL CHART				
SFI-400 - TUBE STYLE WITH THREADED OR FLANGED CONNECTIONS				
Example	SFI	-400SS	-1-1/2	SFI-400SS-1-1/2
Model Designator	SFI			Sight flow indicator
Body Style		400CI 400SS 400F		Female NPT connections, cast iron body (only for 1 through 2 inch sizes) Female NPT connections, 316 SS body Raised face flange connection, 316 SS body (only for 1 inch and up sizes)
Body Size			1/2 3/4 1 1-1/4 1-1/2 2 3 4	1/2 inch connection size 3/4 inch connection size 1 inch connection size 1-1/4 inch connection size 1-1/2 inch connection size 2 inch connection size 3 inch connection size 4 inch connection size
<b>Note:</b> Best for use in vertical pipelines where there are no mechanical strains.				

MODEL CHART					
SFI-300F - WINDOW STYLE WITH FLANGED CONNECTIONS					
Example	SFI	-360FSS	-1-1/2	-G1	SFI-360FSS-1-1/2-G1
Model Designator	SFI				Sight flow indicator
Body Style		350FCS 350FSS 360FCS 360FSS			Carbon steel body, no moving indicator 316 SS body, no moving 316 SS indicator Carbon steel body, 316 SS flapper 316 SS body, 316 SS flapper
Body Size			1-1/2 2 3 4 6		1-1/2 inch raised face flange connection size 2 inch raised face flange connection size 3 inch raised face flange connection size 4 inch raised face flange connection size 6 inch raised face flange connection size
Options				G1 G2	PTFE gasket Fluoroelastomer gasket

MODEL CHART					
SFI-700 - TUBE STYLE WITH THREADED CONNECTIONS					
Example	SFI	-700SS	-1-1/2	-BSPT	SFI-700SS-1-1/2-BSPT
Model Designator	SFI				Sight flow indicator
Body Style		700 700SS			Brass body 316 SS body
Body Size			1/4 3/8 1/2 3/4 1 1-1/4 1-1/2		1/4 inch female NPT connection size 3/8 inch female NPT connection size 1/2 inch female NPT connection size 3/4 inch female NPT connection size 1 inch female NPT connection size 1-1/4 inch female NPT connection size 1-1/2 inch female NPT connection size
Options				BSPT BSPP	BSPT threads BSPP threads



SERIES V4 | W. E. ANDERSON™ BY DWYER



# FLOTECT® VANE OPERATED FLOW SWITCH

Field Adjustable — Dependable Protection Against Flow Variation or Stopping in Pipelines for Fluids, Gases and Flowing Solids

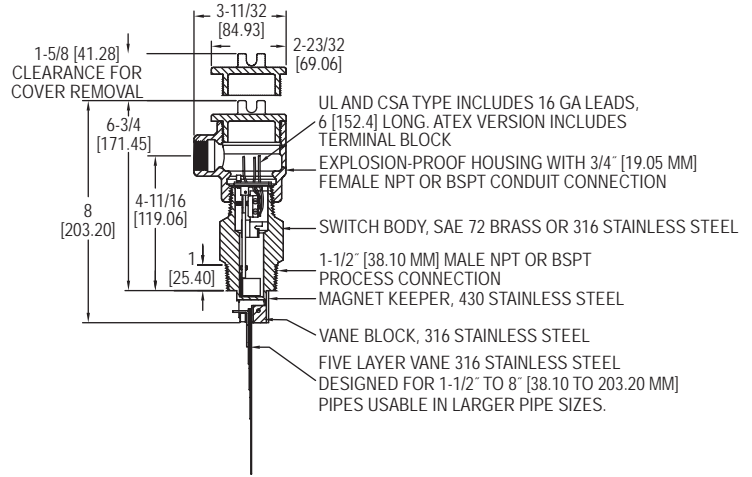

The **Series V4 FloTECT® Vane Operated Flow Switch** is rugged and reliable, ideal for automatically protecting equipment and pipeline systems against damage from reduction or loss of flow. Time tested in thousands of pipeline installations and processing plants around the world this Series is Weatherproof, designed to meet NEMA 4 and Explosion-proof (listing included in specifications). This series can be used in pipes 1-1/2" (38.10 mm) and up.

### FEATURES/BENEFITS

- Unique magnetically actuated switching design gives superior performance
- Features a free-swinging vane which attracts a magnet within the solid metal switch body, actuating a snap switch by means of a simple lever arm with no bellows, springs, or seals to fail
- Leak proof body machined from bar stock
- Electrical assembly can be easily replaced without removing the unit from installation so that the process does not have to be shut down
- Installs directly and easily into pipeline with a thredolet, tee, or flange (see application drawings)
- High pressure rating of 1000 psig (69 bar) with the brass body and 2000 psig (138 bar) with the 316 SS body
- Choice of custom vane calibrated for your application, Model V4, or field adjustable multilayer vane, Model V4-2-U (see set point chart)

### APPLICATIONS

- Protects pumps, motors and other equipment against low or no flow
- Controls sequential operation of pumps
- Automatically starts auxiliary pumps and engines
- Stops liquid cooled engines, machines and processing when coolant flow is interrupted
- Shuts down burner when air flow through heating coil fails
- Controls dampers according to flow

### SPECIFICATIONS

**Service:** Gases or liquids compatible with wetted materials.

**Wetted Materials:** Vane: 316 SS; Body: Brass or 316 SS standard; Magnet Keeper: 430 SS standard, 316 SS optional; Options: Other materials also available, consult factory (e.g. PVC, Hastelloy, Nickel, Monel, Titanium).

**Temperature Limit:** -4 to 275°F (-20 to 135°C) standard, MT high temperature option 400°F (205°C) [MT option not UL, CSA, ATEX or IECEx] ATEX and IECEx options, ambient temperature -4 to 163°F (-20 to 73°C); Process temperature -4 to 163°F (-20 to 73°C).

**Pressure Limit:** Brass body 1000 psig (69 bar), 316 SS body 2000 psig (138 bar), optional 5000 psig (345 bar) available with 316 SS body and SPDT switch only.

**Enclosure Rating:** Weatherproof and Explosion-proof. \*\*Listed with UL and CSA for Class I, Groups C and D; Class II, Groups E, F, and G. ATEX **CE** 0344 **Ex** II 2 G Ex d IIB T6 Gb -20°C ≤ Tamb ≤ 73°C. -20°C ≤ Process Temp ≤ 73°C. EC-Type Certificate No.: KEMA 03 ATEX 2383. ATEX Standards: EN60079-0: 2009; EN60079-1: 2007. IECEx Certified: For Ex d IIB T6 Gb -20°C ≤ Tamb ≤ 73°C. -20°C ≤ Process Temps ≤ 73°C.

**IECEx Certificate of Conformity:** IECEx DEK 11.0071. IECEx Standards: IEC 60079-0: 2007; IEC 60079-1: 2007. Zone I. Also FM approved.

**Switch Type:** SPDT snap switch standard, DPDT snap switch optional.

**Electrical Rating:** UL, FM, ATEX and IECEx models 10 A @ 125/250 VAC (V~). CSA models: 5 A @ 125/250 VAC (V~); 5 A res., 3 A ind. @ 30 VDC (V=); 1 A res., .5 A ind. @ 30 VDC (V=); 1 A res., .5 A ind. @ 30 VDC (V=). MT option: 5 A @ 125/250 VAC (V~). [MT and MV option not UL, CSA, FM, ATEX or IECEx].

**Electrical Connections:** UL and CSA models: 16 AWG, 6" (152 mm) long. ATEX and IECEx unit: Terminal block.

**Conduit Connection:** 3/4" female NPT or 19.05 mm standard or M25 with -BSPT option.

**Process Connection:** 1-1/2" male NPT or 1-1/2" male BSPT or 38.10 mm.

**Mounting Orientation:** Within 5° of vertical for proper operation. Units for horizontal installation (vertical pipe with up flow) available.

**Set Point Adjustment:** For universal vane: five vane combinations.

**Weight:** 4 lb 8 oz (1.9 kg).

**Agency Approvals:** ATEX, CE, CSA, FM, IECEx, UL\*\*.

\*\*No housing option (-NH) has no approvals

MODEL CHART		
Model	Description	Connection Type
V4-2-U	Brass body, universal vane	NPT
V4-SS-2-U	316 SS* body, universal vane	NPT
V4-2-U-NH**	Brass body, universal vane, no housing	NPT
V4	Brass body, custom vane	NPT
V4-SS	316 SS* body, custom vane	NPT
V4-NH**	Brass body, custom vane, no housing	NPT
V4-2-U-BSPT	Brass body, universal vane	BSPT
V4-SS-2-U-BSPT	316 SS* body, universal vane	BSPT
V4-BSPT	Brass body, custom vane	BSPT
V4-SS-BSPT	316 SS* body, custom vane	BSPT

**Note:** Consult factory for price and availability of fittings for V4 installation. Thredolets, bushings, and tees are available in a variety of sizes and materials.

**Note:** For custom vane models, please supply factory with following information: pipe size, flow direction (horizontal, up), mounting, pressure, temperature, specific gravity, flow rates (maximum normal, actuation/deactuation†), etc.

\*316 SS body with 430 SS magnet keeper

\*\*No housing option (-NH) has no approvals

†When both values are supplied, note which is critical

OPTIONS	
To order add suffix:	Description
-D	DPDT contacts
-MV	Gold plated contacts, options for dry circuits*
-MT	High temperature, option rated 400°F (204°C)*
-TRI	Increasing flow time delay relay option with 2 SPDT contacts, adjustable from 0-1 to 0-31 minutes*
-TRD	Decreasing flow time delay relay option with 2 SPDT contacts, adjustable from 0-1 to 0-31 minutes*
-316	316 SS magnet keeper, option to replace standard 430 SS
-V	Vertical up flow, option for upward flow in vertical pipe
-AT	ATEX compliant construction
-IEC	IECEx certified construction
-BSPT	Female BSPT process connection and M25 conduit connection

\*See electrical rating in specification, no listings or approvals

USA: California Proposition 65  
 ⚠WARNING: Cancer and Reproductive Harm - www.P65Warnings.ca.gov

# FLOTECT® VANE OPERATED FLOW SWITCH

Field Adjustable — Dependable Protection Against Flow Variation or Stopping in Pipelines for Fluids, Gases and Flowing Solids

## V4 UNIVERSAL VANE FLOW CHARTS

Values shown in both charts are nominal. If normal flows exceed actuation rates by less than 10%, custom vanes are recommended. Figures are based on standard vertical installation in a 1-1/2" threaded branch connection in a horizontal run of pipe.

APPROXIMATE ACTUATION/DEACTUATION FLOW RATES FOR COLD WATER; GPM (LPM)												
Vane Layers	1.5" Pipe	2" Pipe	3" Pipe	4" Pipe	6" Pipe	8" Pipe	10" Pipe	12" Pipe	14" Pipe	16" Pipe	18" Pipe	20" Pipe
1	7-3 (26.67-11.67)	15-8 (56.7-30)	45-22 (167-83.3)	95-40 (367-150)	210-120 (800-450)	375-175 (1417-667)	600-300 (2267-1133)	900-450 (3400-1700)	1200-600 (4550-2267)	1400-800 (5300-3033)	2000-1000 (7567-3783)	2400-1200 (9083-4550)
1 & 2		7-4 (26.7-15)	23-14 (86.7-53.3)	50-35 (190-132)	130-90 (500-333)	230-150 (867-567)	450-250 (1700-950)	650-350 (2467-1317)	900-500 (3400-1900)	1200-650 (4550-2467)	1450-800 (5483-3033)	1800-1000 (6817-3783)
1, 2 & 3			11-7 (41.7-26.7)	27-19 (102-71.7)	80-60 (300-233)	160-115 (600-433)	300-180 (1133-683)	450-275 (1700-1033)	600-350 (2267-1317)	750-450 (2750-2083)	1000-600 (3783-2267)	1200-700 (4550-2650)
1, 2, 3 & 4				17-12 (65-45)	60-45 (233-167)	120-90 (450-333)	230-150 (867-567)	310-200 (1167-750)	430-280 (1633-1067)	550-360 (2083-1367)	700-450 (2650-1700)	850-550 (3217-2083)
1, 2, 3, 4 & 5					40-30 (152-113)	80-65 (300-250)	135-100 (517-383)	200-140 (750-533)	290-200 (1100-750)	360-250 (1367-950)	460-325 (1733-1233)	575-400 (2183-1517)

Actuation rates are based on cold water at a specific gravity of 1.0.  
For fluids of different specific gravity, actuation rates may be approximated by dividing the rate shown by the square root of the specific gravity.

APPROXIMATE ACTUATION/DEACTUATION FLOW RATES FOR COLD AIR; SCFM (LPS)												
Vane Layers	1.5" Pipe	2" Pipe	3" Pipe	4" Pipe	6" Pipe	8" Pipe	10" Pipe	12" Pipe	14" Pipe	16" Pipe	18" Pipe	20" Pipe
1	32-17 (15-8)	65-32 (30-20)	210-105 (100-50)	400-200 (190-90)	950-475 (450-220)	1550-850 (730-400)	2400-1300 (1100-600)	3450-1900 (1600-900)	4700-2600 (2200-1200)	6400-3500 (3000-1700)	8000-4400 (3800-2100)	10000-5500 (4700-2600)
1 & 2		23-13 (10-6)	120-70 (60-30)	195-140 (90-70)	550-375 (260-180)	1100-700 (520-330)	1850-1200 (870-570)	2700-1750 (1300-800)	3400-2200 (1600-1000)	4800-3100 (2300-1500)	6000-3900 (2800-1800)	7400-4800 (3500-2300)
1, 2 & 3			60-48 (30-20)	135-100 (60-50)	375-265 (180-130)	725-500 (340-240)	1200-850 (570-400)	1850-1300 (870-610)	2600-1800 (1200-800)	3350-2350 (1600-1100)	4300-3000 (2000-1400)	5300-3700 (2500-1700)
1, 2, 3 & 4				65-50 (30-20)	260-200 (120-90)	500-400 (240-190)	875-700 (410-330)	1250-1000 (590-470)	1900-1500 (900-710)	2500-2000 (1200-900)	3100-2500 (1500-1200)	3900-3100 (1800-1500)
1, 2, 3, 4 & 5					130-100 (60-50)	310-250 (150-120)	650-525 (310-250)	1000-800 (470-380)	1600-1250 (760-590)	2200-1750 (1040-830)	2800-2250 (1300-1100)	3550-2850 (1700-1300)

Actuation rates are based on air at standard conditions.  
For gases at other pressures, temperatures, or specific gravities, consult factory for equivalent flow approximations.

## APPLICATION DRAWINGS FOR FLOTECT® AUTOMATIC FLOW SWITCHES

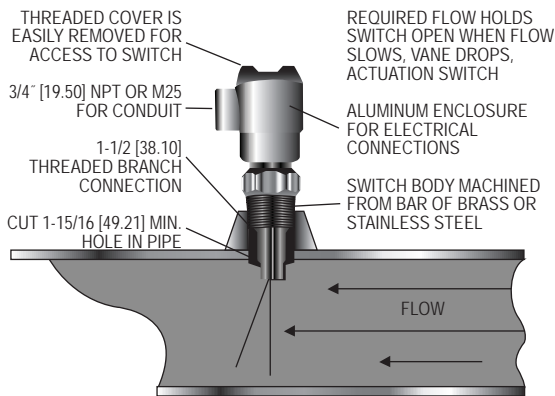

**Threaded branch connection installation.**  
May also be installed using tee, flange or coupling.

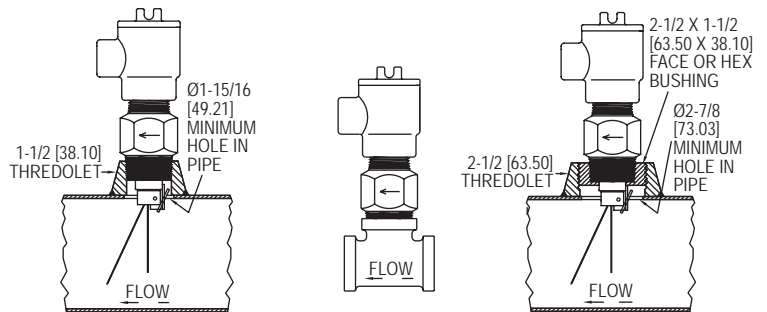

**Standard installation**  
**1-1/2" x 1-1/2" x 1-1/2" (38.10 x 38.10 x 38.10 mm) tee installation**  
**2-1/2" (63.50 mm) threaded branch connection**

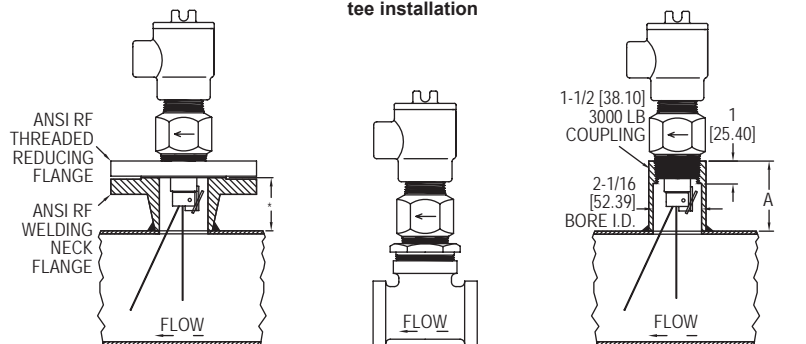

**Flange installation**  
\*Flange face to pipe O.D. specified by customer. Normally should not exceed 5" (127)  
**2" x 2" x 2" (50.80 x 50.80 x 50.80 mm) tee installation**  
**Not recommended, unless coupling is bored out to 2-1/16" (52.4) as shown**

Pipe Size	Dim. A
2" (50.80 mm)	2-5/8 (66.7)
3" (76.20 mm)	2-1/2 (63.5)
4" (101.60 mm)	2-7/16 (61.9)

# FLOTECT® MINI-SIZE FLOW SWITCHES

Monitor Flow in 1/2" to 2" (12.70 to 50.80 mm) Pipe, Explosion-Proof, Compact



V6 with tee

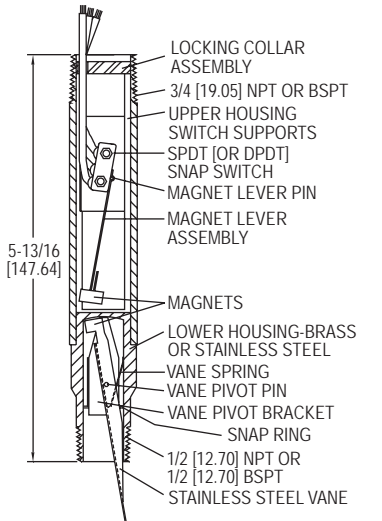

OVERALL LENGTH WITH 1-1/4" TEE CONNECTION APPROXIMATELY 8" [31.75 TO 203.20 MM]



V6 low flow

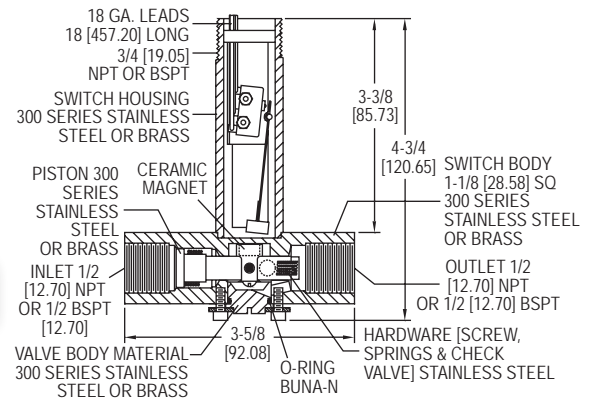

The **Series V6 FloTECT® Mini-Size Flow Switches** are surprisingly compact, and specifically engineered to monitor liquid, gas, or air flows. Time tested in thousands of pipeline installations and processing plants around the world, this Series is Weatherproof, designed to meet NEMA 4 and Explosion-proof (listing included in specifications). Tees are available for installation in pipelines from 1/2" to 2" (12.70 to 50.80 mm). With bushings added the unit is easily adapted to 1/4" and 3/8" (6.35 and 9.53 mm) piping.

## FEATURES/BENEFITS

- Unique magnetically actuated switching design gives superior performance
- Features a free-swinging vane which attracts a magnet within the solid metal switch body, actuating a snap switch by means of a simple lever arm with no bellows, springs, or seals to fail
- Leak proof body machined from bar stock
- Electrical assembly can be easily replaced without removing the unit from installation so that the process does not have to be shut down
- Choice of models in a tee with calibrated vane or field adjustable trimmable vane
- Easy installation with simple pipe insert via tee and simple electrical switch connections
- High pressure rating of 1000 psig (69 bar) with the brass body and 2000 psig (138 bar) with the 316 SS body
- Low flow model offers field adjustable set point

## APPLICATIONS

- Protects pumps, motors and other equipment against low or no flow
- Controls sequential operation of pumps
- Automatically starts auxiliary pumps and engines
- Stops liquid cooled engines, machines and processing when coolant flow is interrupted
- Shuts down burner when air flow through heating coil fails
- Controls dampers according to flow
- Signals alarm when emergency shower or eyewash station in use

## SPECIFICATIONS

**Service:** Gases or liquids compatible with wetted materials.

**Wetted Materials:** Standard V6 Models: Vane: 301 SS; Lower Body: brass or 303 SS; Magnet: Ceramic; Other: 301, 302 SS; Tee: Brass, iron, forged steel, or 304 SS. V6 Low Flow Models: Lower body: Brass or 303 SS; Tee: Brass or 304 SS; Magnet: Ceramic; O-ring: Buna-N standard, Fluoroelastomer optional; Other: 301, 302 SS.

**Temperature Limits:** -4 to 220°F (-20 to 105°C) Standard, MT high temperature option 400°F (205°C) (MT not UL, CSA, ATEX, IECEx or KC) ATEX Compliant AT, IECEx IEC Option and KC (KC Option), Ambient Temperature -4 to 167°F (-20 to 75°C) Process Temperature: -4 to 220°F (-20 to 105°C).

**Pressure Limit:** Brass lower body with no tee models 1000 psig (69 bar), 303 SS lower body with no tee models 2000 psig (138 bar), Brass tee models 250 psi (17.2 bar), iron tee models 1000 psi (69 bar), forged and stainless steel tee models 2000 psi (138 bar), low flow models 1450 psi (100 bar).

**Enclosure Rating:** Weatherproof and Explosion-proof. Listed with UL and CSA for Class I, Groups A, B, C and D; Class II, Groups E, F, and G. (Group A on stainless steel body models only).

ATEX 0344 II 2 G Ex d IIC T6 Gb Process Temp ≤75°C Alternate Temperature Class T5 Process Temp ≤90°C, 115°C (T4) Process Temp ≤105°C consult factory. EC-type Certificate No.: KEMA 04ATEX2128.

ATEX Standards: EN 60079-0: 2009; EN 60079-1: 2007.

IECEx Certified: For Ex d IIC T6 Gb Process Temp ≤75°C Alternate Temperature Class T5 Process Temp ≤90°C, 115°C (T4) Process Temp ≤105°C consult factory. IECEx Certificate of Conformity: IECEx DEK 11.0039;

IECEx Standards: IEC 60079-0: 2007; IEC 60079-1: 2007;

Korean Certified (KC) for: Ex d IIC T6 Gb Process Temp ≤75°C;

KTL Certificate Number: 2012-2454-75.

**Switch Type:** SPDT snap switch standard, DPDT snap switch optional.

**Electrical Rating:** UL models: 5 A @ 125/250 VAC. CSA, ATEX and IECEx models: 5 A @ 125/250 VAC (V~); 5 A res., 3 A ind. @ 30 VDC (V---). MV option: .1 A @ 125 VAC (V~). MT option: 5 A @ 125/250 VAC (V~). [MT option not UL, CSA, ATEX or IECEx].

**Electrical Connections:** UL models: 18 AWG, 18" (457.20 mm) long. ATEX/CSA / IECEx models: terminal block.

**Upper Body:** Brass or 303 stainless steel.

**Conduit Connections:** 3/4" (19.05 mm) male NPT standard, 3/4" (19.05 mm) female NPT or M25 with BSPT option on junction box models.

**Process Connection:** 1/2" (12.70 mm) male NPT or 1/2" (12.70 mm) male BSPT on models without a tee.

**Mounting Orientation:** Switch can be installed in any position but the actuation/deactuation flow rates in the charts are based on horizontal pipe runs and are nominal values.

**Set Point Adjustment:** Standard V6 models none. Without tee models vane is trimmable. Low flow models are field adjustable in the range shown. See set point charts.

**Weight:** 2 to 6 lb (.9 to 2.7 kg) depending on construction.

**Options not Shown:** Custom calibration, bushings, PVC tee, reinforced vane, DPDT relays.

**Agency Approvals:** ATEX, CE, CSA, IECEx, KTL, UL.

USA: California Proposition 65

⚠WARNING: Cancer and Reproductive Harm - www.P65Warnings.ca.gov

●Set Point Charts: See page 273 (Series V6)





# FLOTECT® MINI-SIZE FLOW SWITCHES

Monitor Flow in 1/2" to 2" (12.70 to 50.80 mm) Pipe, Explosion-Proof, Compact

MODEL CHART										
Example	V6	EP	B-B	-S	-2		-B	-MT	V6EPB-B-S-2-B-MT	
Series	V6								Flow switch	
Construction		EP							Explosion proof	
Body			B-B S-S						Brass SS	
Circuit (Switch)				S D					SPDT DPDT	
Tee Connection Size+					1 2 3 4 5 6 LF LF				1/2" (12.70 mm) 3/4" (19.50 mm) 1" (25.40 mm) 1-1/4" (31.75 mm) 1-1/2" (38.10 mm) 2" (50.80 mm) Low flow model (1/2" connection-brass) Low flow model (1/2" connection-SS)	
Process Connection							- E		NPT BSPT	
Tee Material+							MI FS B S O		Iron Forged steel Brass SS No tee, field trimmable vane** (For LF model no tee material chosen, tee material matches body choice)	
Options								CSA AT IEC MV MT VIT	CSA approved construction with junction box* ATEX compliant construction with junction box IECEx certified construction with junction box Gold contacts on snap switch for dry circuits (see specifications for ratings) High temperature option rated 400°F (205°C) (see specifications for ratings)* Fluoroelastomer O-rings in place of Buna-N on low flow models	

**Note:** M25 is not available with the CSA housing.  
 +Additional adders dependent on tee connection size and tee material, consult factory for these adders.  
 \*Options that do not have ATEX.  
 \*\*Vane will be trimmed to the connection size. If full field trimmable vane is desired, must select with tee connection size 6.

MODEL CHART			
Model	Size/Connection	Body	Tee
V6EPB-B-S-1-B	1/2" (12.70 mm) NPT	Brass	Brass
V6EPB-B-S-2-B	3/4" (19.50 mm) NPT	Brass	Brass
V6EPB-B-S-3-B	1" (25.40 mm) NPT	Brass	Brass
V6EPB-B-S-4-B	1-1/4" (31.75 mm) NPT	Brass	Brass
V6EPB-B-S-5-B	1-1/2" (38.10 mm) NPT	Brass	Brass
V6EPB-B-S-6-B	2" (50.80 mm) NPT	Brass	Brass
V6EPB-B-S-1-MI	1/2" (12.70 mm) NPT	Brass	Iron
V6EPB-B-S-2-MI	3/4" (19.50 mm) NPT	Brass	Iron
V6EPB-B-S-3-MI	1" (25.40 mm) NPT	Brass	Iron
V6EPB-B-S-4-MI	1-1/4" (31.75 mm) NPT	Brass	Iron
V6EPB-B-S-5-MI	1-1/2" (38.10 mm) NPT	Brass	Iron
V6EPB-B-S-6-MI	2" (50.80 mm) NPT	Brass	Iron
V6EPS-S-S-1-FS	1/2" (12.70 mm) NPT	SS	FS
V6EPS-S-S-2-FS	3/4" (19.50 mm) NPT	SS	FS
V6EPS-S-S-3-FS	1" (25.40 mm) NPT	SS	FS
V6EPS-S-S-4-FS	1-1/4" (31.75 mm) NPT	SS	FS
V6EPS-S-S-5-FS	1-1/2" (38.10 mm) NPT	SS	FS
V6EPS-S-S-6-FS	2" (50.80 mm) NPT	SS	FS
V6EPS-S-S-1-S	1/2" (12.70 mm) NPT	SS	SS
V6EPS-S-S-2-S	3/4" (19.50 mm) NPT	SS	SS
V6EPS-S-S-3-S	1" (25.40 mm) NPT	SS	SS
V6EPS-S-S-4-S	1-1/4" (31.75 mm) NPT	SS	SS
V6EPS-S-S-5-S	1-1/2" (38.10 mm) NPT	SS	SS
V6EPS-S-S-6-S	2" (50.80 mm) NPT	SS	SS
V6EPB-B-S-6-0	No tee	Brass	None
V6EPS-S-S-6-0	No tee	SS	None
V6EPB-B-S-LF	1/2" (12.70 mm) NPT	Brass	LF, brass
V6EPS-S-S-LF	1/2" (12.70 mm) NPT	SS	LF, SS
V6EPB-B-S-LFE	1/2" (12.70 mm) BSPT	Brass	Brass
V6EPB-B-S-1E-B	1/2" (12.70 mm) BSPT	Brass	Brass
V6EPB-B-S-2E-B	3/4" (19.50 mm) BSPT	Brass	Brass
V6EPB-B-S-3E-B	1" (25.40 mm) BSPT	Brass	Brass
V6EPB-B-S-4E-B	1-1/4" (31.75 mm) BSPT	Brass	Brass
V6EPB-B-S-5E-B	1-1/2" (38.10 mm) BSPT	Brass	Brass
V6EPB-B-S-6E-B	2" (50.80 mm) BSPT	Brass	Brass
V6EPB-B-S-6E-0	No tee	Brass	Brass
V6EPS-S-S-LFE	1/2" (12.70 mm) BSPT	SS	SS
V6EPS-S-S-1E-S	1/2" (12.70 mm) BSPT	SS	SS
V6EPS-S-S-2E-S	3/4" (19.50 mm) BSPT	SS	SS
V6EPS-S-S-3E-S	1" (25.40 mm) BSPT	SS	SS
V6EPS-S-S-4E-S	1-1/4" (31.75 mm) BSPT	SS	SS
V6EPS-S-S-5E-S	1-1/2" (38.10 mm) BSPT	SS	SS
V6EPS-S-S-6E-S	2" (50.80 mm) BSPT	SS	SS
V6EPS-S-S-6E-0	No tee	SS	SS

### V6 SET POINT CHARTS - FACTORY INSTALLED TEE

APPROXIMATE ACTUATION/DEACTUATION FLOW RATES FOR AIR; SCFM (LPM)		
Pipe Size	Actuate	Deactuate
1/2"	6.50 (180)	5.00 (120)
3/4"	10.0 (300)	8.00 (240)
1"	14.0 (420)	12.0 (360)
1-1/4"	21.0 (600)	18.0 (540)
1-1/2"	33.0 (960)	30.0 (840)
2"	43.0 (1200)	36.0 (1020)

APPROXIMATE ACTUATION/DEACTUATION FLOW RATES FOR COLD WATER; GPM (LPM)		
Pipe Size	Actuate	Deactuate
1/2"	1.50 (5.667)	1.00 (3.83)
3/4"	2.00 (7.5)	1.25 (4.67)
1"	3.00 (11.33)	1.75 (6.67)
1-1/4"	4.00 (15.17)	3.00 (11.3)
1-1/2"	6.00 (22.67)	5.00 (18.9)
2"	10.00 (37.83)	8.50 (32.2)

### V6 LOW FLOW SET POINT CHART

MIN-MAX FLOW RATES IN 1/2" PIPE		
Media	Actuate	Deactuate
GPM-water	.04-0.75	.03-0.60
LPM-water	.15-2.84	.11-2.27
SCFM-air	.18-2.70	.15-2.0
LPS-air	.09-1.3	.07-.95

Pressure drop (head loss) is a function of both set point and flow rate. Typically, pressure drop at actuation flow rate listed will be 5-10 psid (.34-.69 bar). Pressure drops at other flow rates will vary in proportion to the (change in flow).

USA: California Proposition 65  
 ⚠️WARNING: Cancer and Reproductive Harm - www.P65Warnings.ca.gov



SERIES V7 | W. E. ANDERSON™ BY DWYER



# FLOTECT® VANE OPERATED FLOW SWITCH

Magnetic Linkage, UL Approved

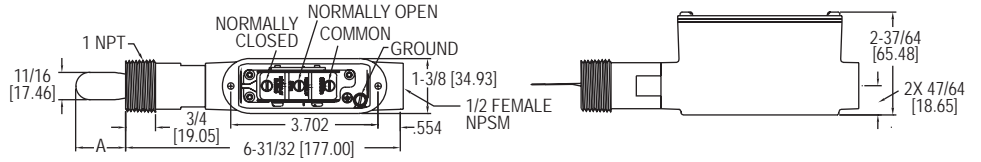

Pipe Size	Dim. A	Pipe Size	Dim. A
1	1-17/64 [32.15]	2	2-11/64 [55.17]
1-1/4	1-19/32 [40.48]	3	2-11/64 [55.17]
1-1/2	1-53/64 [46.43]	4	2-11/64 [55.17]

The Series V7 Flotect® Vane Flow Switch is an inexpensive range switch for use with compatible liquids to start or stop electronic operated equipment when flow or no-flow conditions occur. Design is standard weatherproof, meeting NEMA 4X.

**FEATURES/BENEFITS**

- Magnetically actuated switching design gives superior performance
- Features a free-swinging vane which attracts a magnet within the solid metal switch body, actuating a snap switch by means of a simple lever arm with no bellows, springs, or seals to fail
- Lower body is machined solid metal bar stock assuring no leak points, no matter how long the unit is in service
- Robust vane design is rigid and field trimmable for set point adjustment

**APPLICATIONS**

- Proof of boiler flow
- Shuts down burner when air flow through heating coil fails
- Protects pumps, motors and other equipment against low or no flow
- Stops liquid cooled engines, machines and processing when coolant flow is interrupted

APPROXIMATE ACTUATION/DEACTUATION FLOW RATES FOR COLD WATER; GPM (LPM)		
Pipe Size	Actuate	Deactuate
1"	7.5 (28.4)	6.8 (25.7)
1-1/4"	8.1 (30.8)	7.6 (28.9)
1-1/2"	11.7 (44.1)	10.9 (41.3)
2"	16.9 (64.0)	15.6 (59.1)
2-1/2"	19.6 (74.2)	18.1 (68.5)
3"	31.6 (120)	29.6 (112)
4"	58.0 (218)	52.0 (197)

Contact the factory for different actuation-deactuation rates.

**SPECIFICATIONS**

**Service:** Liquids compatible with wetted materials that are non-coating and non-crystallizing.  
**Wetted Materials:** Vane: 301 SS; Process connection: Brass or 316 SS; Magnet: Ceramic; Other: 301, 302 SS.  
**Upper Body Material:** Die cast aluminum.  
**Temperature Limits:** -40 to 250°F (-40 to 121°C).  
**Pressure Limits:** 250 psi (17.2 bar).  
**Enclosure Rating:** Weatherproof, meets NEMA 4X (IP66).  
**Switch Type:** SPDT snap switch.  
**Electrical Rating:** 10 A @ 125, 250, 480 VAC; 1/8 hp @ 125 VAC, 1/4 hp @ 250 VAC.  
**Electrical Connections:** 3 screw type, common, normally open and normally closed.  
**Conduit Connection:** 1/2" NPSM.  
**Process Connection:** 1" male NPT. Contact factory for optional tees.  
**Pipe Size:** 1" to 4".  
**Mounting Orientation:** Horizontal or vertical (actuation flow rates are based on horizontal pipe runs in the vertical position). Will not work in vertical pipe with down flow.  
**Set Point Adjustment:** Vane is trimmable, see set point chart.  
**Weight:** 1 lb 2 oz (500 g).  
**Agency Approvals:** CE, UL.

MODEL CHART	
Model	Body Material
V7-WBS-30N	Brass
V7-WSS-30N	316 SS

USA: California Proposition 65  
 ⚠ WARNING: Cancer and Reproductive Harm - www.P65Warnings.ca.gov

SERIES V10 | W. E. ANDERSON™ BY DWYER



# FLOTECT® MINI-SIZE FLOW SWITCH

Proof of Flow or No Flow in 1/2 to 2" Pipe, Cost Effective, Leak Proof Body, Weatherproof

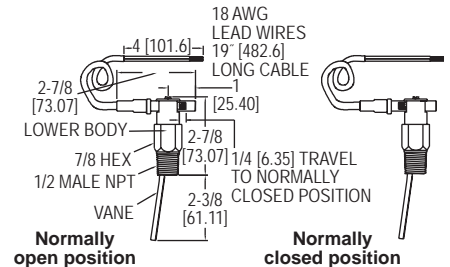

The Series V10 Flotect® Mini-Size Flow Switch is designed to provide inexpensive, reliable monitoring of the presence or absence of flow in a system. This series is available for field installation in pipelines from 1/2 to 2" diameter and available in brass or 303 SS body.

**FEATURES/BENEFITS**

- Magnetically actuated switching design gives superior performance with rugged, hermetically sealed reed switch
- Simple field switch adjustment allows user to toggle between Normally Open (NO) or Normally Closed (NC) with no change in the electrical connection
- Switch housing is located outside the process media, allowing simple switch change-over or maintenance without interruption of process flow
- Full size, field trimmable stainless steel vane provided with removable template calibrated for brass or ductile iron reducing tees with forged steel straight tee/bushing combinations

**APPLICATIONS**

- Proving flow in boilers, hot water heaters, and chillers
- Protects pumps, motors and other equipment against low or no flow
- Automatically starts auxiliary pumps and engines

APPROXIMATE ACTUATION/DEACTUATION FLOW RATES FOR COLD WATER; GPM (LPM)				APPROXIMATE ACTUATION/DEACTUATION FLOW RATES FOR AIR; SCFM (LPM)			
Pipe Size	Trim	N.O.	N.C.	Pipe Size	Trim	N.O.	N.C.
1/2"	L	2.6/2.3 (9.8/8.7)	2.6/2.5 (9.8/9.5)	1/2"	L	10.3/8.8 (291.7/250)	10.2/9.2 (288/260)
3/4"	J	3.1/2.7 (11.7/10.2)	3.1/2.8 (11.7/10.6)	3/4"	J	13/11.6 (368.3/328)	12.9/11.6 (365/328)
1"	H	4.8/4.5 (18.2/17)	4.8/4.4 (18.2/16.7)	1"	H	19.2/17.6 (543.3/498)	18.9/17.6 (535/498)
1-1/4"	E	6.2/5.6 (23.5/21.2)	6.1/5.6 (23.1/21.2)	1-1/4"	E	24.8/22.2 (701.7/628)	24.5/22.5 (693/637)
1-1/2"	C	8.2/7.7 (31/29.1)	8.2/7.7 (31/29.1)	1-1/2"	C	33.4/31.2 (946.7/883)	33/30.6 (935/867)
2"	Full	9.5/9.1 (36/34.4)	9.5/9 (36/34.1)	2"	Full	50.2/48.4 (1422/1370)	50.2/47.7 (1422/1352)

**SPECIFICATIONS**

**Service:** Compatible gases or liquids.  
**Wetted Materials:** Vane: 301 SS; Body: Brass or 303 SS; Pin and Magnet: Ceramic 8.  
**Temperature Limit:** 200°F (93°C).  
**Pressure Limit:** Brass body: 1000 psig (69 bar); 303 SS body: 2000 psig (138 bar).  
**Enclosure Rating:** Weatherproof, meets NEMA 4X (IP66).  
**Switch Type:** SPST hermetically sealed reed switch. Field adjustable for normally open or normally closed.  
**Electrical Rating:** 0.5 A @ 120 VAC; 1.5 A @ 24 VDC res.; 0.001 A @ 200 VDC res.  
**Electrical Connections:** 18 AWG, 19" (483 mm) long, PVC jacket. Rated 221°F (105°C).  
**Process Connection:** 1/2" male NPT or 1/2" male BSPT.  
**Mounting Orientation:** Switch can be installed in any position but the actuation/deactuation flow rates are based on horizontal pipe runs and are nominal values.  
**Set Point Adjustment:** Vane is trimmable.  
**Weight:** 5.5 oz (0.16 kg).  
**Agency Approvals:** CE, CSA, UR.  
**Switch Enclosure:** Nylon.

MODEL CHART			
Model	Body Material	Connection Type	Switch Configuration
V10	Brass	NPT	Normally open or closed
V10SS	303 SS	NPT	Normally open or closed
V10-BSPT	Brass	BSPT	Normally open or closed
V10SS-BSPT	303 SS	BSPT	Normally open or closed

USA: California Proposition 65  
 ⚠ WARNING: Cancer and Reproductive Harm - www.P65Warnings.ca.gov

# FLOTECT® VANE OPERATED FLOW SWITCHES

Field Adjustable — 1 to 6 Inch Pipe, Leak Proof Body, Chemical Resistance



V8

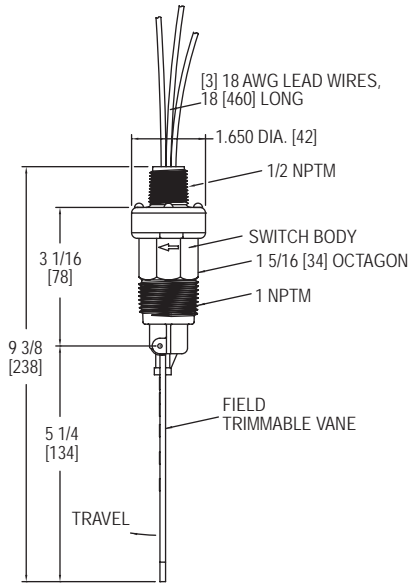

V8-WP2

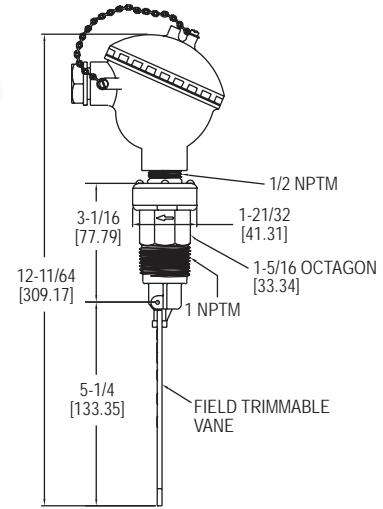

The **Series V8 Flotect® Vane Operated Flow Switches** are ideal for protecting unattended equipment from damage or loss of production. This Series is available for installation in a 1 to 6" pipe with operating pressures up to 150 psig (10 bar) and temperatures to 212°F (100°C).

**FEATURES/BENEFITS**

- UL recognized as an industrial motor controller per UL standard 508, suitable for mounting in a protected environment
- Magnetically actuated switching design gives superior performance with free-swinging vane which attracts a magnet within the switch body, actuating a snap switch with no bellows, springs, or seals to fail
- Leak proof body and vane constructed of tough durable polyphenylene sulfide which has excellent chemical resistance
- A full size trimmable vane is provided with molded-in graduations

**APPLICATIONS**

- Chemical processing
- Air conditioning
- Refrigeration
- Heating systems
- Cooling lines
- Machinery
- Liquid transfer systems
- Water treatment
- Food processing
- Machine tools

APPROXIMATE ACTUATION/DEACTUATION FLOW RATES FOR COLD WATER; GPM (LPM)	
Pipe Size	Actuate/Deactuate
1"	10.8/9.1 (40.9/34.6)
1-1/4"	9.8/8.3 (37.2/31.4)
1-1/2"	8.6/6.8 (32.4/25.7)
2"	10.9/8.8 (41.2/33.4)
3"	12.9/8.9 (48.8/33.5)
4"	21.1/13.8 (79.7/52.2)
6"	45/33 (170.2/124.7)

APPROXIMATE ACTUATION/DEACTUATION FLOW RATES FOR AIR; SCFM (LPM)	
Pipe Size	Actuate/Deactuate
1"	39/32.6 (1105/923)
1-1/4"	37.5/32.2 (1062/912)
1-1/2"	33.4/26.7 (945/757)
2"	43/36.8 (1218/1042)
3"	52.7/38.9 (1493/1100)
4"	87.6/63.6 (2482/1802)
6"	168.6/137.4 (4775/3890)

**SPECIFICATIONS**

**Service:** Compatible gases or liquids.  
**Wetted Materials:** Vane and body: Polyphenylene Sulfide (PPS); Pin and spring: 316 SS or Inconel®; Magnet: Ceramic 8.  
**Temperature Limit:** 212°F (100°C).  
**Pressure Limit:** 150 psig (10.34 bar).  
**Enclosure Rating:** General purpose, WP/WP2 option is weatherproof.  
**Switch Type:** SPDT snap switch, MV option: SPDT gold contact snap switch.  
**Electrical Rating:** 5 A @ 125/250 VAC, 5 A resistive, 3 A inductive @ 30 VDC; MV option: 1 A @ 125 VAC, 1 A resistive, 0.5 A inductive @ 30 VDC.  
**Electrical Connections:** 18 AWG, 18" (460 mm) long.  
**Conduit Connection:** 1/2" male NPT, 1/2" female NPT on WP and WP2.  
**Process Connection:** 1" male NPT.  
**Mounting Orientation:** Actuation/deactuation flow rates are based on horizontal pipe runs and are nominal values. Unit cannot be used with vertical down flow.  
**Set Point Adjustment:** Vane is trimmable.  
**Weight:** 4.5 oz (0.13 kg).  
**Agency Approvals:** CE, cURus.

**MODEL CHART**

Model	Description
V8	Flow switch

**OPTIONS**

To order add suffix:	Description
-MV	Gold plated contacts, for dry circuits; rated 1A @ 125 VAC; 1A resistive, 0.5A inductive @ 30 VDC
<b>Example: V8-MV</b>	
-INC	Inconel® alloy option; Inconel® alloy replaces standard 316 SS wetted parts; wetted parts are Inconel® alloy, ceramic 8, and polyphenylene sulfide
<b>Example: V8-INC</b>	
-WP	Weatherproof enclosure; optional housing is phenylpolioxide and provides weatherproof protection for electrical wiring; not UL approved
<b>Example: V8-WP</b>	
-WP2	Optional housing is aluminum and provides weatherproof protection for electrical wiring; not UL approved
<b>Example: V8-WP2</b>	



SERIES FS-2 | W. E. ANDERSON™ BY DWYER



# VANE FLOW SWITCH

Low Cost, Field Adjustable Set Point and Paddle

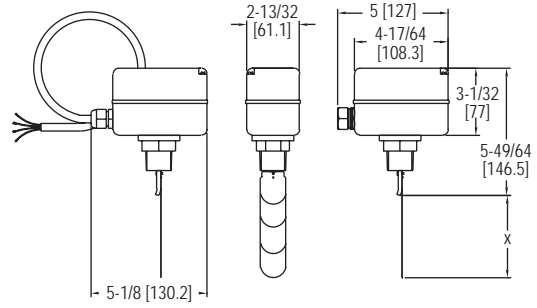

Shown with conduit connection option

The **Series FS-2 Vane Flow Switch** offers an economical flow proving solution. The FS-2 paddles are adjustable to fit 1 to 8" size pipe.

**FEATURES/BENEFITS**

- Field adjustable set point adjustment screw allows for easy flow switch modification
- Custom application set points enabled by field adjustable vane layers
- Aluminum weatherproof housing permits outdoor installation

**APPLICATIONS**

- Boiler flow proving
- Hot water heaters
- Chillers
- Cooling lines
- Machinery
- Liquid transfer systems

**APPROXIMATE ACTUATION/DEACTUATION FLOW RATES FOR WATER; GPM (LPM)**

Pipe Size	Blade Vane Length in (mm) Dim. X	Minimum Setting		Maximum Setting	
		Actuate	Deactuate	Actuate	Deactuate
1"	1.34 (34)	4.0 (15.0)	1.8 (6.7)	8.8 (33.3)	6.6 (25.0)
1-1/4"	1.34 (34)	5.3 (20.0)	2.6 (10.0)	11.4 (43.3)	8.4 (31.7)
1-1/2"	2.24 (57)	7.0 (26.7)	4.0 (15.0)	14.5 (55.0)	11.4 (43.3)
2"	2.24 (57)	14.1 (53.3)	9.7 (36.7)	31.3 (118.3)	22.5 (85.0)
2-1/2"	3.46 (88)	18.5 (70.0)	15.4 (58.3)	35.2 (133.3)	30.8 (116.7)
3"	3.46 (88)	27.7 (105.0)	25.1 (95.0)	52.8 (200.0)	46.2 (175.0)
4"	3.46 (88)	59.4 (225.0)	52.8 (200.0)	123.3 (466.7)	114.5 (433.3)
5"	6.57 (167)	52.8 (200.0)	39.6 (150.0)	132.1 (500.0)	123.3 (466.7)
6"	6.57 (167)	75.7 (286.7)	52.8 (200.0)	154.1 (583.3)	140.9 (533.3)
8"	6.57 (167)	184.9 (700.0)	158.5 (600.0)	396.3 (1500.0)	374.2 (1416.7)

**SPECIFICATIONS**

**Service:** Compatible liquids.  
**Wetted Materials:** Bellow: Tin-bronze; Vane: SS; Body: Forged brass.  
**Temperature Limit:** 230°F (110°C).  
**Pressure Limit:** 145 psig (10 bar).  
**Enclosure Rating:** NEMA 4 (IP64).  
**Switch Type:** SPDT snap switch.  
**Electrical Rating:** 10 A res, 3 A ind @ 250 VAC.  
**Electrical Connection:** Cable gland with attached wire leads or optional conduit connection.

**Process Connection:** 1" male NPT or BSPT.  
**Mounting Orientation:** Switch must be installed vertically on horizontal pipe runs.  
**Set Point Adjustment:** Four vane combinations and an adjustment screw.  
**Enclosure:** Die-cast aluminum alloy.  
**Weight:** 28.22 oz (0.8 kg).  
**Agency Approvals:** CE.

**MODEL CHART**

Model	Description
FS-2	Paddle flow switch

**OPTIONS**

To order add suffix:	Description
-BSPT	Process connection
<b>Example:</b> FS-2-BSPT	
-CND	Conduit connection, 1" NPT female conduit connection with no wire leads.
<b>Example:</b> FS-2-CND	

USA: California Proposition 65  
 ⚠ WARNING: Cancer and Reproductive Harm - www.P65Warnings.ca.gov

SERIES TDFS2 | W.E. ANDERSON™ BY DWYER



# THERMAL DISPERSION FLOW SWITCH

Non-Mechanical, Low Pressure Drop

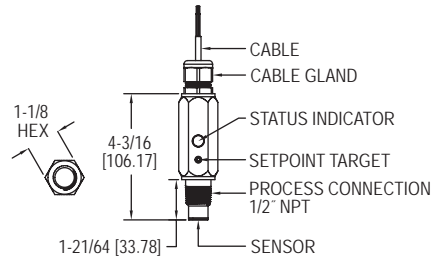

The **Series TDFS2 Thermal Dispersion Flow Switch** is a thermal flow switch that indicates whether the flow rate is above or below a user set flow rate. The unit incorporates two LED status indicators providing visual switch indication. The set flow rate (setpoint) is field adjustable and the unit has both NO and NC NPN outputs.

**FEATURES/BENEFITS**

- Better reliability and life expectancy than mechanical flow switches with no paddles or vanes to wear or break, no jams in the paddle movement, and no seals on movement assembly to wear or leak
- Not affected by empty pipe as it avoids overheating by actively heating above the process temperature and then cooling down to process temperature
- Set point is easily field set by tapping the included magnet on the set point target three times at the desired flow rate
- LED status indicators provide visual switch indication of flow rate in comparison to the set point
- Low pressure drop; only needs to be inserted 10% into the flow (e.g. 1/8" for 3/4" schedule 40 pipe)

**APPLICATIONS**

- Boiler flow proving
- Hot water heaters
- Chillers
- Liquid transfer systems

**MODEL CHART**

Model	Description
TDFS2-1-P-06	Thermal flow switch, 6" (1.83 m) cable with cable gland
<b>Note:</b> Consult factory for longer cable lengths.	

**SPECIFICATIONS**

**Service:** Compatible water-based fluids.  
**Wetted Materials:** 316 SS.  
**Setpoint Range:** 0.5 to 10 ft/s (0.15 to 3.0 m/s).  
**Repeatability:** 0.07 ft/s +3% of setpoint.  
**Typical Deadband:** 0.1 ft/s +15% of setpoint.  
**Temperature Limits:** Ambient: 5 to 140°F (-15 to 60°C), Process: 5 to 140°F (-15 to 60°C), Storage: -40 to 185°F (-40 to 85°C).  
**Pressure Limits:** 300 psig (20.67 bar).  
**Response Time:** Approximately 8 s.  
**Power Requirement:** 9-24 VDC.  
**Switching Current:** 400 mA, derate 5 mA/°C above 23°C.  
**Current Consumption:** Average: 93 mA, Peak: 300 mA.  
**Electrical Connection:** 1/2" NPT cable gland with 4 conductor 22 AWG, 6' (1.83 m) cable.  
**Process Connection:** 1/2" NPT male.  
**Enclosure Rating:** NEMA 4X (IP65).  
**Housing Materials:** 316 SS, 416 SS, polycarbonate, neoprene, and acrylated urethane.  
**Switch Type:** 1 NO NPN, 1 NC NPN.  
**Input Power and Protection:** 0.5A fuse (resettable) reverse polarity protected.  
**Switched Output Protection:** 0.5A fuse (resettable) reverse polarity protected.  
**Agency Approvals:** CE.



# FLOW SWITCH

Ideal for Air and Post-Filtered Water Applications, Fixed Set Point, FDA Compliant

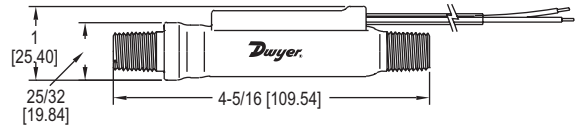
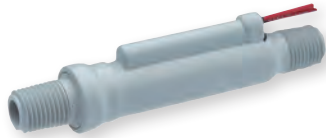

The **Series P2 Flow Switch** utilizes a piston-type design for both air and pure water applications. The switches have preset actuation points from 0.05 to 1.0 GPM for water and 25 CFH to 5 CFM for air. The P2 is comprised of PPE & PS (polyphenylene ether and polystyrene) housing and piston and 316 SS spring and stop pin.

### FEATURES/BENEFITS

- Piston design incorporates a hermetically sealed SPST magnetic reed switch
- All wetted parts are FDA compliant
- Economical design

### APPLICATIONS

- Pure water equipment
- Filter life monitoring
- Heat exchangers
- Cooling applications

### SPECIFICATIONS

<b>Service:</b> Compatible liquids or gases.	<b>Electrical Rating:</b> .17 A @ 120 VAC, .08 A @ 240 VAC, .13 A @ 120 VDC, .06 A @ 240 VDC.
<b>Wetted Materials:</b> Housing: PPE & PS (polyphenylene ether and polystyrene); Piston: PPE & PS and epoxy; Spring and stop pin: 316 SS.	<b>Electrical Connection:</b> 22 AWG, 18" (45.7 cm), PVC lead wires.
<b>Temperature Limits:</b> 0 to 212°F (-18 to 100°C).	<b>Process Connection:</b> 1/4" male NPT.
<b>Pressure Limits:</b> 150 psig (10.3 bar) @ 70°F (21°C); 50 psig (3.4 bar) @ 212°F (100°C).	<b>Mounting Orientation:</b> Any position. Set points shown are based on vertical, inlet down position.
<b>Switch Type:</b> SPST, N.O.	<b>Required Filtration:</b> 50 microns or better.
	<b>Weight:</b> 2 oz (.06 kg).

### MODEL CHART

Model	Media	Actuation Set Point	Model	Media	Actuation Set Point
P2-11	Liquids	.05 GPM (.19 LPM)	P2-15	Gases @ 5 psi	.42 CFM (11.9 LPM)
P2-12	Liquids	.25 GPM (.95 LPM)	P2-16	Gases @ 5 psi	1.0 CFM (28.3 LPM)
P2-13	Liquids	.50 GPM (1.89 LPM)	P2-17	Gases @ 5 psi	2.5 CFM (70.8 LPM)
P2-14	Liquids	1.0 GPM (3.79 LPM)	P2-18	Gases @ 5 psi	5.0 CFM (141.6 LPM)

## SERIES P3

# POLYPROPYLENE FLOW SWITCHES

Fixed Set Points from 0.25 to 2.0 GPM, 3/8" NPT or "Quick Disconnect" Adapters

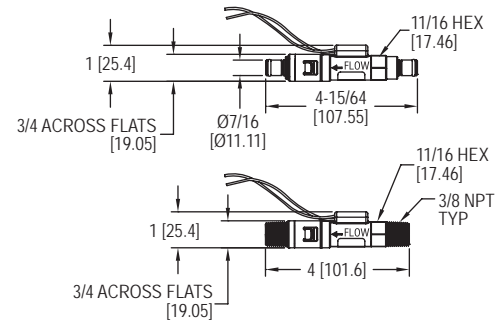

The **Series P3 Polypropylene Flow Switches** fit almost any piping requirements with compatible liquids. Choose the inlet and outlet port to be 3/8" male NPT or 1/4" male "Quick Disconnect" then select a quick disconnect acetal adapter for straight through flow or with a shut off valve.

### FEATURES/BENEFITS

- Piston design incorporates a hermetically sealed SPST magnetic reed switch
- Easy integration to existing piping with a variety of fitting options
- Selectable shut off valve will stop line flow when the adapter is removed from the switch
- Economical design

### APPLICATIONS

- Pure water equipment
- Filter life monitoring
- Heat exchangers
- Cooling applications

### SPECIFICATIONS

<b>Service:</b> Compatible liquids.	<b>Electrical Rating:</b> .08 A @ 120 VAC.
<b>Wetted Materials:</b> Housing: Polypropylene; Piston: PPS composite; Spring: 316 SS; O-ring: Fluorocarbon.	<b>Electrical Connection:</b> 24" (60.96 cm), polymeric wire leads, 22 AWG.
<b>Temperature Limits:</b> 0 to 212°F (-18 to 100°C).	<b>Process Connection:</b> 3/8" male NPT or 1/4" quick disconnect.
<b>Pressure Limits:</b> 125 psig (8.6 bar) @ 70°F (21°C), 50 psig (3.4 bar) @ 212°F (100°C).	<b>Mounting Orientation:</b> Any position. Set points shown are based on vertical, inlet down position.
<b>Accuracy:</b> 20% of set point.	<b>Required Filtration:</b> 100 microns or better.
<b>Repeatability:</b> ±1%.	<b>Weight:</b> 5 oz (0.14 kg).
<b>Switch Type:</b> SPST, NO.	

### MODEL CHART

Model	Connection	Actuation Set Point
P3-31	3/8" NPT	0.25 GPM (.95 LPM)
P3-32	3/8" NPT	0.50 GPM (1.89 LPM)
P3-33	3/8" NPT	1.0 GPM (3.79 LPM)
P3-34	3/8" NPT	1.5 GPM (5.68 LPM)
P3-35	3/8" NPT	2.0 GPM (7.57 LPM)
P3-41	Quick disconnect	0.25 GPM (.95 LPM)
P3-42	Quick disconnect	0.50 GPM (1.89 LPM)
P3-43	Quick disconnect	1.0 GPM (3.79 LPM)
P3-44	Quick disconnect	1.5 GPM (5.68 LPM)
P3-45	Quick disconnect	2.0 GPM (7.57 LPM)

### ADAPTERS

Model	Connection
P3-801	Quick disconnect straight through 1/4" NPT
P3-802	Quick disconnect straight through 1/4" BSPT
P3-804	Quick disconnect straight through 3/8" BSPT
P3-807	Quick disconnect straight through 1/4" ID tubing
P3-901	Quick disconnect straight through 1/4" NPT w/shut-off valve
P3-902	Quick disconnect straight through 1/4" BSPT w/shut-off valve
P3-907	Quick disconnect straight through 1/4" ID tubing w/shut-off valve

# BRASS FLOW SWITCH

Fixed Set points, Flow Rates from 0.10 to 1.5 GPM

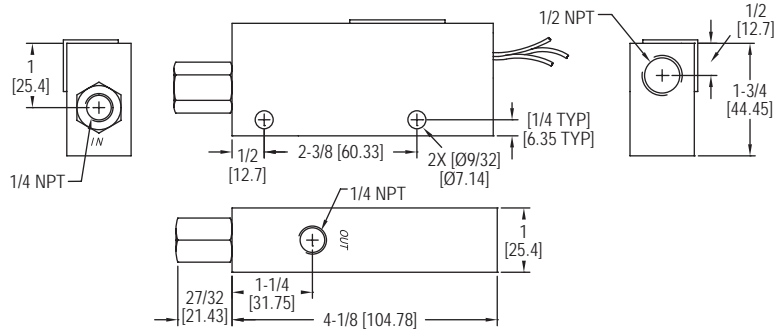
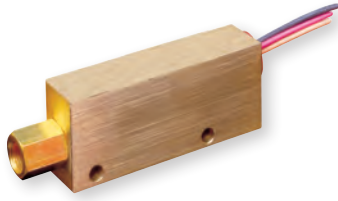

The **Series P1 Brass Flow Switch** utilizes a piston-type design for accurate detection of excessive or insufficient liquid flow rates. The switches have preset actuation points from 0.10 to 1.5 GPM for liquid flow.

**FEATURES/BENEFITS**

- Piston-type operation yields accurate detection of low flow rates
- The piston magnetically actuates a hermetically sealed SPST reed switch

**APPLICATIONS**

- Industrial cleaning equipment
- Detecting loss of fluid in hydraulic systems
- Assuring proper coolant flow in semiconductor processing

MODEL CHART	
Model	Actuation Set Point* GPM (LPM)
P1-011	0.10 (.38)
P1-012	0.25 (.95)
P1-013	0.50 (1.89)
P1-014	0.75 (2.84)
P1-015	1.00 (3.79)
P1-016	1.50 (5.68)

\*Calibrated for water at standard conditions.

**SPECIFICATIONS**

**Service:** Compatible liquids.  
**Wetted Materials:** Housing: Brass; Piston: Polysulfone; Spring: 316 SS; O-ring: Fluoroelastomer; Other: Epoxy.  
**Temperature Limits:** -20 to 225°F (-29 to 107°C).  
**Pressure Limits:** 1000 psig (68.9 bar).  
**Accuracy:** ±10% of set point.  
**Repeatability:** ±1%.  
**Switch Type:** SPDT.  
**Electrical Rating:** .17 A @ 120 VAC, .08 A @ 240 VAC, .13 A @ 120 VDC, .06 A @ 240 VDC.  
**Electrical Connection:** 18 AWG, 24" (60.96 cm), polymeric lead wires.  
**Process Connection:** 1/4" female NPT.  
**Mounting Orientation:** Any position. Set points shown are based on vertical, inlet down position.  
**Required Filtration:** 50 microns or better.  
**Weight:** 0.66 lb (301 g).  
**Agency Approvals:** CE.

USA: California Proposition 65  
 ⚠WARNING: Cancer and Reproductive Harm - www.P65Warnings.ca.gov

SERIES P8

# HIGH PRESSURE BRASS FLOW SWITCH

Up to 1500 psi, Fixed Set point, Up to 2.0 GPM, Rugged Brass Body

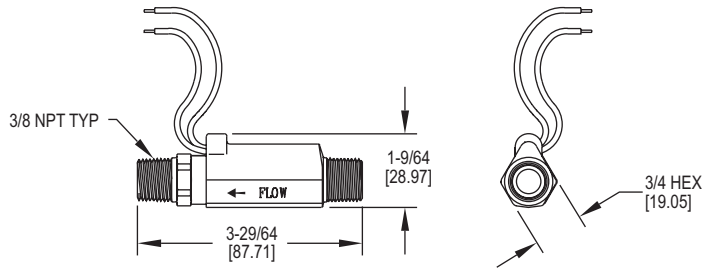
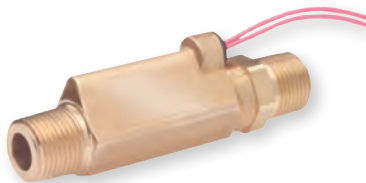

The **Series P8 High Pressure Brass Flow Switch** is ideal for high in-line pressures. Set points range from 0.25 to 2.0 GPM for liquid flow.

**FEATURES/BENEFITS**

- Integrates a one-piece magnetic PPS composite piston to handle pressure up to 1500 psi
- Less susceptible to clogging than other high in-line pressure switches with 100 micron filtration

**APPLICATIONS**

- Industrial cleaning equipment
- High pressure lubrication systems

MODEL CHART	
Model	Actuation Set Point GPM (LPM)
P8-11	0.25 (.95)
P8-12	0.50 (1.89)
P8-13	1.0 (3.79)
P8-14	1.5 (5.68)
P8-15	2.0 (7.57)

**SPECIFICATIONS**

**Service:** Compatible liquids.  
**Wetted Materials:** Housing: Brass; Piston: PPS composite, epoxy; Spring: 316 SS; O-ring: Fluorocarbon.  
**Temperature Limits:** -20 to 275°F (-28 to 135°C).  
**Pressure Limits:** 1500 psi (103.4 bar).  
**Accuracy:** ±20% of set point.  
**Switch Type:** SPST, NO.  
**Electrical Rating:** .17 A @ 120 VAC, .08 A @ 240 VAC, .13 A @ 120 VDC, .06 A @ 240 VDC.  
**Electrical Connection:** No. 22 AWG, 24" (61 cm), polymeric leads.  
**Process Connections:** 3/8" male NPT.  
**Mounting Orientation:** Any position. Set points shown are based on vertical, inlet down position.  
**Required Filtration:** 100 microns or better.  
**Weight:** 6 oz (.17 kg).  
**Agency Approvals:** CE.

USA: California Proposition 65  
 ⚠WARNING: Cancer and Reproductive Harm - www.P65Warnings.ca.gov

# GLOBE VALVE SWITCH

Adjustable Set Point, Rugged Bronze Construction, Straight Through Flow

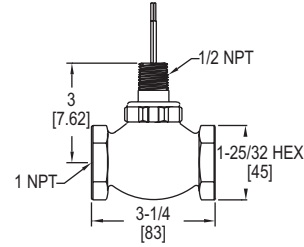

The **Series GVS Globe Valve Switch** offers accurate flow detection with 1% repeatability and external adjustability over a broad range of flow settings for compatible liquids.

**FEATURES/BENEFITS**

- Externally adjustable flow set point
- Durable construction delivers long-life reliability in either water or oil
- Ample space for flow to pass keep pressure drop low

**APPLICATIONS**

- Detection of improper flow rates in high volume lubrication
- Low flow detection in cooling lines
- Flow detection in process systems

MODEL CHART	
Model	Actuation Set Point Range GPM (LPM)
GVS-111	1.0 to 6.0 (3.8 to 22.7)
GVS-112	5.0 to 15.0 (18.9 to 56.8)
GVS-113	2.0 to 8.0 (7.6 to 30.3)

SPECIFICATIONS
<b>Service:</b> Compatible liquids.
<b>Wetted Materials:</b> Housing: Bronze; Shuttle: TFE; Bonnet: Bronze; Spring: 316 SS.; Other: Fluoroelastomer, ceramic.
<b>Temperature Limits:</b> -20 to 200°F (-29 to 93°C).
<b>Pressure Limits:</b> 400 psig (27 bar) @ 100°F (38°C).
<b>Accuracy:</b> ±10%.
<b>Repeatability:</b> 1% maximum deviation.
<b>Switch Type:</b> SPDT.
<b>Electrical Rating:</b> .17 A @ 120 VAC, .08 A @ 240 VAC, .13 A @ 120 VDC, .06 A @ 240 VDC.
<b>Electrical Connections:</b> 18 AWG, 24" (61 cm), polymeric lead wires.
<b>Process Connections:</b> 1" female NPT.
<b>Mounting Orientation:</b> Any position. Set points shown are based on horizontal, lead wires up positional.
<b>Required Filtration:</b> 150 microns or better.
<b>Weight:</b> 2 lb, 8 oz (1.16 kg).

USA: California Proposition 65  
 ⚠ WARNING: Cancer and Reproductive Harm - www.P65Warnings.ca.gov

SERIES AFS

# ADJUSTABLE FLOW SWITCH

For Oils, Water and Gases, Infinite Adjustments

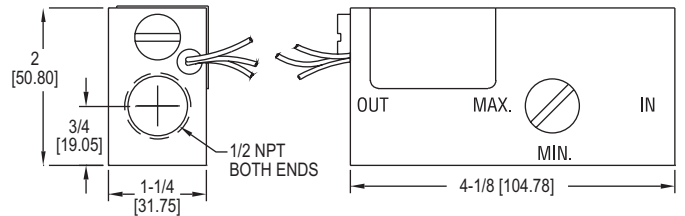

The **Series AFS Adjustable Flow Switch** is externally adjustable piston-type flow switches for oils, liquids and gases. This Series offers an infinite number of flow settings from 0.5 to 20 GPM.

**FEATURES/BENEFITS**

- Externally adjustable flow set point
- Offers a number of flow settings at pressures up to 1000 psig, with low pressure drop and precise repeatability

**APPLICATIONS**

- Protecting machine tools from coolant flow failure
- Protecting bearings from loss of lubricant
- Assuring proper air flow
- Water or compatible liquid control
- Oil flow control
- Control of gas flows

MODEL CHART				
Model	Media	Electrical Connection	Piston	Housing
AFS-131	Oil	Wire leads	Brass	Brass
AFS-141	Water	Wire leads	Polysulfone	Brass
AFS-151	Liquids	Wire leads	316 SS	316 SS
AFS-231	Gases	Wire leads	Brass	Brass
AFS-251	Gases	Wire leads	316 SS	316 SS
AFS-132	Oil	1/2" NPT conduit	Brass	Brass
AFS-142	Water	1/2" NPT conduit	Polysulfone	Brass
AFS-152	Liquids	1/2" NPT conduit	316 SS	316 SS
AFS-232	Gases	1/2" NPT conduit	Brass	Brass
AFS-252	Gases	1/2" NPT conduit	316 SS	316 SS

SPECIFICATIONS
<b>Service:</b> Compatible gases or liquids.
<b>Wetted Materials:</b> Housing and Piston: See model chart; Spring: 316 SS; O-ring: Fluoroelastomer; Other: Epoxy.
<b>Temperature Limits:</b> -20 to 300°F (-29 to 149°C), -20 to 225°F (-29 to 107.2°C) with polysulfone piston.
<b>Pressure Limit:</b> 1000 psi (68 bar).
<b>Accuracy:</b> ±10% of set point.
<b>Repeatability:</b> ±1% maximum deviation.
<b>Switch Type:</b> SPDT.
<b>Electrical Rating:</b> .17 A @ 120 VAC, .08 A @ 240 VAC, .13 A @ 120 VDC, .06 A @ 240 VDC.
<b>Electrical Connections:</b> 18 AWG, 24" (61 cm), polymeric lead wires, optional 1/2" male NPT conduit connection.
<b>Process Connection:</b> 1/2" female NPT ports.
<b>Mounting Orientation:</b> Any.
<b>Set Point Adjustment:</b> Liquids: 0.5 to 20 GPM (1.9 to 75.7 LPM); Gases: 1.0 to 75 SCFM (28 to 2124 LPM) at 5 psig.
<b>Required Filtration:</b> 50 microns or better.
<b>Weight:</b> 2 lb, 11 oz (1.22 kg).
<b>Agency Approvals:</b> CE.

USA: California Proposition 65  
 ⚠ WARNING: Cancer and Reproductive Harm - www.P65Warnings.ca.gov



Flow Switches,  
Shuttle/Piston

# IN-LINE FLOW ALARM

Latching Alarm Capabilities, For Air, Water or Caustic Fluids, Unrestricted Mounting

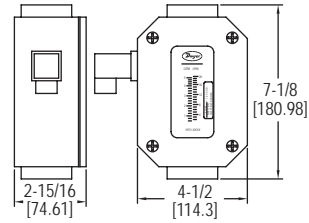

The **Series HFO In-Line Flow Alarm** provides continuous monitoring and control of flow rate levels. The flow alarm can be configured to open or close a contact for an increasing or decreasing set point. Available in 1/4", 1/2", 1" or 1-1/2" female NPT process connections, in aluminum, brass or 304 SS body.

**FEATURES/BENEFITS**

- Provides two 10 A SPDT limit switches with field adjustable alarm settings for application control and integral direct reading scale provides local indication of flow rate
- Increased application versatility with no inlet or outlet straight plumbing requirement and can be mounted horizontally, vertically, or inverted
- Outdoor or harsh environment installation capable with rugged cast aluminum construction and NEMA 4X (IP65) enclosure

**APPLICATIONS**

- Waste water processing
- Lubrication systems
- Process control
- Solar systems
- Drain lines
- Pump testing

MODEL CHART - DUAL SCALE RANGE			
Model	Connection Size	Range, Air: SCFM, SLPS	Body Material
HFO-21112	1/4" female NPT	2 to 12, 1 to 5.5	Aluminum
HFO-21123	1/4" female NPT	4 to 23, 2 to 10	Aluminum

**SPECIFICATIONS**

**Service:** Compatible gases or liquids.  
**Wetted Materials:** Body: Aluminum, brass or 304 SS; Seals: Buna-N or fluoroelastomer; Magnet: PTFE coated Alnico; Other internal parts: 304 SS.  
**Viscosity:** 500 SSU.  
**Temperature Limits:** 170°F (76°C).  
**Pressure Limits:** Aluminum body: 600 psig (41 bar); Brass body: 3500 psig (240 bar); 304 SS body: 6000 psig (413 bar).  
**Enclosure Rating:** NEMA 4X (IP66).  
**Accuracy:** ±2% FS.  
**Repeatability:** ±1% of FS.  
**Switch Type:** SPDT, 10 A @ 250 VAC; 0.5 A @ 125 VDC, (resistive).  
**Shipping Weight:** 1/4 to 1/2" female NPT models: 3 lb (1.4 kg); 3/4 to 1" female NPT models: 4.5 lb (2.0 kg); 1-1/2" female NPT models: 12 lb (5.4 kg).

MODEL CHART			
Model	Connection Size	Range, Water: GPM, LPM	Body Material
HFO-22205	1/2" female NPT	0.5 to 5.0, 2 to 19	Brass
HFO-22315	3/4" female NPT	1 to 15, 5 to 55	Brass
HFO-22320	3/4" female NPT	2 to 20, 10 to 74	Brass
HFO-22440	1" female NPT	4 to 40, 20 to 150	Brass
HFO-22550	1-1/2" female NPT	6 to 50, 20 to 190	Brass
HFO-23202	1/2" female NPT	.2 to 2, 1 to 8	304 SS
HFO-23210	1/2" female NPT	1 to 10, 3 to 37.5	304 SS

USA: California Proposition 65  
 ⚠WARNING: Cancer and Reproductive Harm - www.P65Warnings.ca.gov

SERIES HFT

# IN-LINE FLOW TRANSMITTER

Local Flow Indication, Unrestricted Mounting, 4-20 mA, 0-5 V, and 1-5 V Output

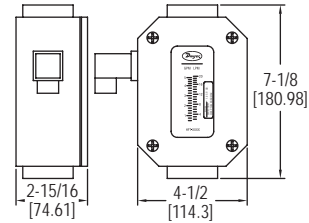

The **Series HFT In-Line Flow Transmitter** provides continuous monitoring of flow rate levels via a direct reading in-line flowmeter with electronics to provide proportional 4-20 mA, 0-5 and 1-5 VDC analog outputs.

**FEATURES/BENEFITS**

- Provides analog output to monitor application flow and integral direct reading scale to provide local indication of flow rate
- Increased application versatility with no inlet or outlet straight plumbing requirement and can be mounted horizontally, vertically, or inverted
- Outdoor or harsh environment installation capable with rugged cast aluminum construction and NEMA 4X (IP65) enclosure

**APPLICATIONS**

- Waste water processing
- Lubrication systems
- Process control
- Solar systems
- Drain lines
- Pump testing
- Drive data acquisition devices, meters or analog input cards

MODEL CHART - DUAL SCALE RANGE			
Model	Connection Size	Range, Air: SCFM, SLPS	Body Material
HFT-1112	1/4" female NPT	2 to 12, 1 to 5.5	Aluminum
HFT-1123	1/4" female NPT	4 to 23, 2 to 10	Aluminum

**SPECIFICATIONS**

**Service:** Compatible gases or liquids.  
**Wetted Materials:** Body: Aluminum, brass or 304 SS; Seals: Buna-N or Fluoroelastomer; Magnet: PTFE coated Alnico; Other internal parts: 304 SS.  
**Viscosity:** 500 SSU.  
**Temperature Limits:** 170°F (76°C).  
**Pressure Limits:** Aluminum body: 600 psig (41 bar); Brass body: 3500 psig (240 bar); 304 SS body: 6000 psig (413 bar).  
**Power Requirements:** 12-35 VDC.  
**Enclosure Rating:** NEMA 4X (IP66).  
**Accuracy:** ±2% FS.  
**Repeatability:** ±1% of FS.  
**Response Time:** < 100 ms.  
**Output Signal:** 4-20 mA; 0-5 V; 1-5 V.  
**Shipping Weight:** 1/4 to 1/2" female NPT models: 3 lb (1.4 kg); 3/4 to 1" female NPT models: 4.5 lb (2.0 kg); 1-1/2" female NPT models: 12 lb (5.4 kg).

MODEL CHART			
Model	Connection Size	Range, Water: GPM, LPM	Body Material
HFT-2205	1/2" female NPT	0.5 to 5.0, 2 to 19	Brass
HFT-2315	3/4" female NPT	1 to 15, 5 to 55	Brass
HFT-2320	3/4" female NPT	2 to 20, 1 to 75	Brass
HFT-2440	1" female NPT	4 to 40, 15 to 150	Brass
HFT-2550	1-1/2" female NPT	6 to 50, 20 to 190	Brass
HFT-3202	1/2" female NPT	.2 to 2, 1 to 8	304 SS
HFT-3210	1/2" female NPT	1 to 10, 3 to 3.75	304 SS

OPTIONS	
Use order code:	Description
NISTCAL-FT1	NIST traceable calibration certificate

USA: California Proposition 65  
 ⚠WARNING: Cancer and Reproductive Harm - www.P65Warnings.ca.gov



# PADDLEWHEEL FLOW SENSOR

Non-Magnetic Sensing, Adjustable for 1-1/2 to 40" (38.1 to 1016 mm) Pipe, Pulse or 4-20 mA

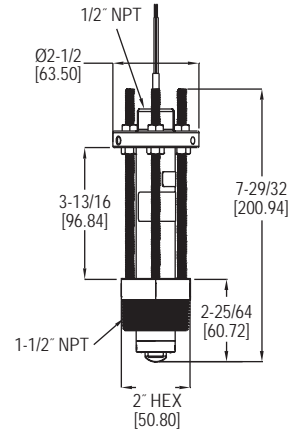

The **Series PFT Paddlewheel Flow Sensor** is used to monitor liquid flow rates in pipes from 1-1/2 to 40" and is available in brass or 316 SS body. The unit outputs a frequency proportional pulsed or 4-20 mA output. The pulse models are a square wave output signal with frequency proportional to the flow velocity and the 4-20 mA models have a linear output of the velocity with 4 mA equal to 0 ft/s and 20 mA equal to 25 ft/s.

**FEATURES/BENEFITS**

- Bearings and shaft offer excellent wear protection even in applications with particulate for long life
- Weatherproof and submersible rated for irrigation applications
- One unit adjustable over a large pipe size range
- Multiple wetted material choices offer application versatility
- Integral 4-20 mA output with no need for additional external components
- Sensor technology uses inductive sensing to sense the blades of the impeller therefor does not use magnets allowing low flow rate monitoring with no concerns regarding magnetic material in the flow

**APPLICATIONS**

- Irrigation
- Ground water remediation
- Cooling systems
- Pump protection
- Leak detection
- Filtration systems

**SPECIFICATIONS**

**Service:** Water-based fluids.  
**Range:** 1.2 to 25 ft/s (0.37 to 7.62 m/s).  
**Wetted Materials:** Body and fitting: Brass or 316 SS; fitting O-ring: FKM standard, silicone or Buna-N optional; impeller: 316 SS; shaft: Tungsten carbide standard or 316 SS optional; bearing: PTFE standard.  
**Linearity:** ±1.0% of FS.  
**Repeatability:** ±0.5% of FS.  
**Temperature Limits:** -40 to 212°F (-40 to 100°C).  
**Pressure Limits:** 400 psig (27.6 bar) @ 100°F (37.8°C), 325 psig (22.4 bar) @ 212°F (100°C).  
**Process Connection:** 1-1/2" NPT male or 1-1/2" BSPT male standard, 2" NPT male or 2" BSPT male optional.  
**Output:** Pulse: NPN open collector with square wave output, rated 60 V @ 50 mA max; Frequency: 3.2 to 200 Hz. Pulse Width: 2.5 msec ±25%; 4-20 mA: 4 mA is 0 ft/s, 20 mA is 25 ft/s.  
**Power Requirement:** 10-35 VDC.  
**Power Consumption:** 40 mA (max.).  
**Electrical Connection:** 22 AWG shielded UL type PTLC rated 105°C, 20' (6.1 m) long with cable gland. Can be extended up to 2000' (609 m) with similar cable. Optional UL listed burial rated cable.  
**Enclosure Rating:** NEMA 6P (IP67)\*.  
**Housing Materials:** Brass or 316 SS.  
**Weight:** 3 lb (1.36 kg).  
**Agency Approvals:** CE.  
 \*Brass units IP67 only.

MODEL CHART			
Model	Body Material	Output	Description
PFT-IAN-B111-S	Brass	4 to 20 mA	1-1/2" NPT connection, FKM seals, tungsten-carbide shaft, PTFE bearing, 20' of cable
PFT-IAN-S111-S	316 SS	4 to 20 mA	1-1/2" NPT connection, FKM seals, tungsten-carbide shaft, PTFE bearing, 20' of cable
PFT-IDN-B111-S	Brass	Pulse	1-1/2" NPT connection, FKM seals, tungsten-carbide shaft, PTFE bearing, 20' of cable
PFT-IDN-S111-S	316 SS	Pulse	1-1/2" NPT connection, FKM seals, tungsten-carbide shaft, PTFE bearing, 20' of cable
PFT-IAN-B311-S	Brass	4 to 20 mA	1-1/2" BSPT connection, FKM seals, tungsten-carbide shaft, PTFE bearing, 20' of cable
PFT-IAN-S311-S	316 SS	4 to 20 mA	1-1/2" BSPT connection, FKM seals, tungsten-carbide shaft, PTFE bearing, 20' of cable
PFT-IDN-B311-S	Brass	Pulse	1-1/2" BSPT connection, FKM seals, tungsten-carbide shaft, PTFE bearing, 20' of cable
PFT-IDN-S311-S	316 SS	Pulse	1-1/2" BSPT connection, FKM seals, tungsten-carbide shaft, PTFE bearing, 20' of cable

Consult factory for longer cable lengths, burial rated cable, 2" NPT connection, or other wetted materials.

Flow Transmitters, Paddlewheel, Adjustable Insertion



SERIES SF | W. E. ANDERSON® BY DWYER



# SIGHT FLOW TRANSMITTER

±2% FS Accuracy, 4-20 mA Output, Pressure up to 500 psig (34 bar)

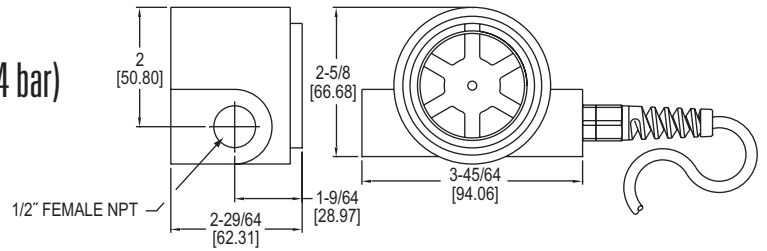

The **Series SF Sight Flow Transmitter** is a Series of sight indicators which can display flow or contents of pipelines and provide an analog 4-20 mA signal proportional to the flow rate. It is available with a 316 SS or clear polycarbonate cover.

**FEATURES/BENEFITS**

- Integrates tangential turbine technology with hermetically sealed circuitry to provide accurate flow measurement and control in the harshest environments
- 2-wire loop-powered design transmits a 4-20 mA signal proportional to flow rate for remote flow monitoring
- Clear polycarbonate viewing cover option for visible indication of flow
- 316 SS cover offers added protection with pressure limit up to 500 psig (34 bar)
- LED power indication, adjustable zero and span, polarity protection and over current limiting
- Accurately measures flow in both directions and can be mounted in any orientation

**APPLICATIONS**

- Cooling and lubrication circuits
- HVAC systems
- Aggressive chemical metering
- Batching systems

MODEL CHART	
Model	Cover Material
SF10	316 SS
SF11	Clear polycarbonate

**SPECIFICATIONS**

**Service:** Compatible liquids.  
**Wetted Materials:** 316 SS shaft and case, Iglide® bearings, Buna-N seal and acetal copolymer, (polycarbonate cover on Model SF11).  
**Flow Range:** 0.5 to 15 GPM (2 to 60 LPM).  
**Accuracy:** ±2% FS.  
**Repeatability:** 0.5% FS.  
**Temperature Limits:** 20 to 225°F (-7 to 107°C).  
**Pressure Limits:** 500 psig (34 bar) Model SF10; 200 psig (14 bar) Model SF11.  
**Response Time:** 2 s to 90% (step change in flow rate).  
**Supply Voltage:** 12-35 VDC.  
**Output:** 4-20 mA.  
**Loop Resistance:** 1150 Ω max.  
**Process Connection:** 1/2" female NPT.  
**Electrical Connection:** Wire leads: 22 AWG x 9' (2.7 m).  
**Max. Particle Size:** 100µm.  
**Agency Approvals:** CE.

OPTIONS	
Use order code:	Description
NISTCAL-FT1	NIST traceable calibration certificate

Iglide® is a registered trademark of Iguis GMBH

SERIES SF2

# SIGHT FLOW METERS

SPDT or Pulse Output, Visual Flow Confirmation, Brass Body



SF2-1



SF2-2

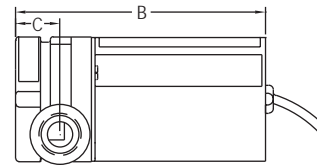
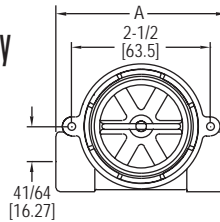

Side view VAC switch models

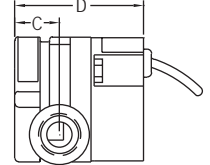

Side view VDC switch and transmitter models

DIMENSIONS in [mm]									
Model	A	B	C	D	Model	A	B	C	D
SF2-104	3-1/64 [76.6]	-	7/8 [22.23]	2-21/64 [59.13]	SF2-134	3-61/64 [100.41]	-	1-1/16 [26.99]	2-61/64 [75]
SF2-101	3-1/64 [76.6]	4-1/2 [114.3]	7/8 [22.23]	-	SF2-131	3-61/64 [100.41]	4-49/64 [121.05]	1-1/16 [26.99]	-
SF2-114	3-1/64 [76.6]	-	7/8 [22.23]	2-21/64 [59.13]	SF2-204	3-1/64 [76.6]	-	13/16 [20.64]	2-21/64 [59.13]
SF2-111	3-1/64 [76.6]	4-1/2 [114.3]	7/8 [22.23]	-	SF2-214	3-1/64 [76.6]	-	13/16 [20.64]	2-21/64 [59.13]
SF2-124	3-61/64 [100.41]	-	1-1/16 [26.99]	2-61/64 [75]	SF2-224	3-61/64 [100.41]	-	1-1/16 [26.99]	2-61/64 [75]
SF2-121	3-61/64 [100.41]	4-49/64 [121.05]	1-1/16 [26.99]	-	SF2-234	3-61/64 [100.41]	-	1-1/16 [26.99]	2-61/64 [75]

The **Series SF2 Sight Flow Meters** combine visual confirmation of flow with a relay or pulse output. The SF2-1 offers a SPDT relay output and the SF2-2 offers a pulse output proportional to the rate of flow. The 4.5-24 VDC pulse output is compatible with most digital logic families.

**FEATURES/BENEFITS**

- Brass, solid body construction, one piece composite rotor, and ceramic shaft delivers durability with broader chemical, temperature, and pressure capabilities
- Set points are fully adjustable over the specified flow range
- The dynamic operation of the rotor guards against jamming and false actuation

**APPLICATIONS**

- Cooling and lubrication circuits
- HVAC systems
- Aggressive chemical metering
- Batching systems

MODEL CHART - SPDT RELAY OUTPUT			
Model	Range (GPM)	Power	Connection
SF2-104	0.5 to 5.0	24 VDC	1/4" female NPT
SF2-101	0.5 to 5.0	110 VAC	1/4" female NPT
SF2-114	4.0 to 20.0	24 VDC	1/2" female NPT
SF2-111	4.0 to 20.0	110 VAC	1/2" female NPT
SF2-124	5.0 to 30.0	24 VDC	3/4" female NPT
SF2-121	5.0 to 30.0	110 VAC	3/4" female NPT
SF2-134	8.0 to 60.0	24 VDC	1" female NPT
SF2-131	8.0 to 60.0	110 VAC	1" female NPT

**SPECIFICATIONS**

**Service:** Liquids compatible with wetted parts.  
**Wetted Materials:** Brass body, ceramic pin, PPS rotor, Polysulfone lens and fluoroelastomer O-ring.  
**Accuracy:** Relay output: ±5%; Pulsed output: ±7% for ranges up to 5.0 GPM, ±15% for ranges up to 60.0 GPM.  
**Temperature Limits:** -20 to 212°F (-29 to 100°C).  
**Pressure Limit:** 200 psig (13.8 bar) @ 70°F.  
**Power Requirements:** See table.

**Output:** SPDT: 1 Amp, 24 VDC resistive; 0.3 Amp, 110 VAC or 4.5-24 VDC pulse depending on model.  
**Electrical Connections:** Relay output models: 20AWG PVC-jacketed, 24" cable; Pulsed output models: 22AWG PVC-jacketed, 24" cable.  
**Process Connections:** See table.  
**Set Point Differential:** 15% max for relay output models.  
**Maximum Viscosity:** 200 SSU.  
**Agency Approvals:** CE.

MODEL CHART - PULSED OUTPUT			
Model	Range (GPM)	Power	Connection
SF2-204	0.5 to 5.0	4.5-24 VDC	1/4" female NPT
SF2-214	4.0 to 20.0	4.5-24 VDC	1/2" female NPT
SF2-224	5.0 to 30.0	4.5-24 VDC	3/4" female NPT
SF2-234	8.0 to 60.0	4.5-24 VDC	1" female NPT

USA: California Proposition 65  
 ⚠️WARNING: Cancer and Reproductive Harm - www.P65Warnings.ca.gov

# SIGHT FLOW INDICATORS/TRANSMITTERS

Low Cost, Optional Output for Flow Rate and Totalization  
UV Stabilized Polycarbonate Model



SFI-801

SFI-800

SFI with A-711 option

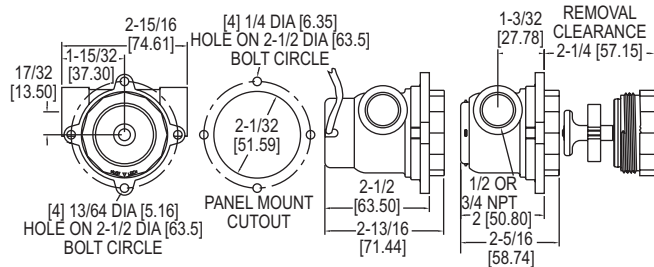

SFI with A-711 option

SFI model only

The Series SFI-800 Sight Flow Indicators/Transmitters are low cost, durable rotor style flow indicators with optional Hall Effect magnetic output packages to combine visual confirmation of flow with optional remote flow monitoring. There are three output sensors available, the A-711 offering two pulsed voltage signals proportional to flow rate, the A-712 which outputs a linear 1-10 VDC signal proportional to flow rate, and the A-713 which offers two programmable open collector switch outputs.

The Model A-711 is a unique and patent pending sensor that outputs two pulsed voltage signals with one providing a 5 VDC pulse and the other a pulse of the input supply voltage used, ranging from 8-18 VDC.

The Model A-712 is a sensor that outputs a linear 1-10 VDC signal proportional to flow rate.

The Model A-713 is a sensor with two programmable open collector switch outputs with one output closed above the set point and the other output closed below the set point ideal for low flow or high flow indication.

**FEATURES/BENEFITS**

- Constructed of clear plastic enabling 360° viewing of the rotor for easy flow indication
- SFI-800 models are constructed of Polysulfone with excellent chemical compatibility, high pressure and temperature ratings, and all wetted materials are FDA/NSF ratable for potable water applications
- SFI-801 models are constructed of UV stabilized Polycarbonate making them ideal for outdoor applications and easy view bright red impeller
- All three output packages can be installed or replaced in the field without any tools and without removing the body from the process line
- Units are weather-tight for outdoor or wash-down area use
- A-713 features a user-friendly set point button which is set at the desired flow rate with red LED indication of switch status

**APPLICATIONS**

- Cooling and lubrication circuits
- HVAC systems
- Aggressive chemical metering
- Batching systems

MODEL CHART - SENSOR ONLY	
Model	Description
A-711	Pulsed output
A-712	1-10 VDC
A-713	Two open collectors

\*Sensor only, not attached to the flow indicator body.

**MODEL CHART - BODY ONLY**

Polysulfone Body Model	Description	Range GPM (LPM)	Connection Female NPT
SFI-800-1/2	Indicator only	2 to 20 (7.6 to 75.5)	1/2"
SFI-800-3/4	Indicator only	3 to 35 (11.4 to 132.5)	3/4"
SFI-800-1/2-LF	Indicator only	0.5 to 6.5 (1.9 to 24.6)	1/2"
Polycarbonate Body Model	Description	Range GPM (LPM)	Connection Female NPT
SFI-801-1/2	Indicator only	2 to 20 (7.6 to 75.5)	1/2"
SFI-801-3/4	Indicator only	3 to 35 (11.4 to 132.5)	3/4"
SFI-801-1/2-LF	Indicator only	0.5 to 6.5 (1.9 to 24.6)	1/2"

**SPECIFICATIONS**

**Service:** Compatible fluids.  
**Wetted Materials:** Body: SFI-800: Polysulfone; SFI-801: UV stabilized polycarbonate; Window: SFI-800: Polysulfone; SFI-801: UV stabilized polycarbonate; Rotor: SFI-800: White polysulfone; SFI-801: Red UV stabilized PBT; Rotor Pin: 316 SS; Thrust washers: 300 Series SS; O-ring: SFI-800: Fluoroelastomer (NSF grade); SFI-801: Buna-N.  
**Temperature Limits:** SFI-800: -20 to 212°F (-29 to 100°C); SFI-801: -20 to 130°F (-29 to 55°C).  
**Pressure Limits:** SFI-800: 150 psi (10.34 bar); SFI-801: 125 psi (8.62 bar).  
**Viscosity Max:** 200 SSU.  
**Weight:** SFI-800: 3.35 oz (95 g); SFI-800-A711: 5.0 oz (142 g).

**ELECTRICAL SPECIFICATIONS (for A-711 Option only)**  
**Temperature Limits:** -20 to 212°F (-29 to 100°C).  
**Power Requirements:** 8-28 VDC.  
**Output Signal:** White lead: 5 VDC; Green lead: 8-28 VDC equal to supply voltage. Pulsed output with frequency rate proportional to flow rate.  
**Accuracy:** ±5% FS.  
**Frequency Output Range:** 0 to 100 Hz.  
**Electrical Connections:** Black lead - ground; White lead: 5 VDC out pulse; Green lead: 8-28 VDC out pulse; Red lead: 8-28 VDC supply.

**ELECTRICAL SPECIFICATIONS (for A-712 option only)**  
**Temperature Limits:** -20 to 212°F (-29 to 100°C).  
**Power Requirements:** 15-28 VDC.  
**Output Signal:** White lead: 1-10 VDC.  
**Accuracy:** ±5% FS.  
**Electrical Termination:** Black lead: Ground; Red lead: 15-28 VDC input; White lead: 1-10 VDC output.

**ELECTRICAL SPECIFICATIONS (for A-713 option only)**  
**Temperature Limits:** -20 to 212°F (-29 to 100°C).  
**Power Requirements:** 8-28 VDC.  
**Output Signal:** White lead: Normally open switch; Green lead: Normally closed switch. Both open collector, 100 mA max, 28 VDC max.  
**Electrical Connections:** Black lead: Ground; White lead: Normally open; Green lead: Normally closed; Red lead: 8-28 VDC.

**OPTIONS - BODY AND SENSORS ATTACHED**

To order add suffix:	Description
-A711	A-711 attached to flow indicator body
<b>Example:</b> SFI-800-1/2-A711	
-A712	A-712 attached to flow indicator body
<b>Example:</b> SFI-800-1/2-A712	
-A713	A-713 attached to flow indicator body
<b>Example:</b> SFI-800-1/2-A713	

# SIGHT FLOW INDICATOR/TRANSMITTER

Output for Flow Rate and Totalization

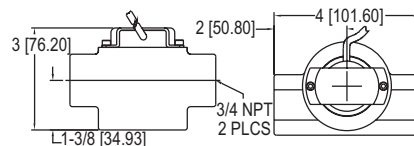

The Series SFI-100T Sight Flow Indicator/Transmitter is a low cost and durable flow transmitter that combines our popular 100 Series Sight Flow Indicator with our A-711T output sensor for visual and remote monitoring of flow. The A-711T output sensor has two pulsed voltage signals with one providing a 5 VDC pulse, the other a pulse of the input supply voltage used, ranging from 8-28 VDC and a pulsed output with a frequency change proportional to the flow rate.

**FEATURES/BENEFITS**

- Constructed of a robust, solid brass body and a tempered glass window
- Bright red impeller yields great visual indication of flow through the window
- Front window can be easily unscrewed to clean out the sight flow indicator
- Ideal for outdoor applications with weatherproof body that is unaffected by UV light

**APPLICATIONS**

- Cooling and lubrication circuits
- HVAC systems
- Monitoring chilled or hot water flow
- Monitoring water flow in chillers

**MODEL CHART**

Model	Description	Range GPM (LPM)	Connection Female NPT
SFI-100T-1/2-A711T	Brass indicator with A-711T sensor	2 to 20 (7.6 to 75.5)	1/2"
SFI-100T-3/4-A711T	Brass indicator with A-711T sensor	3 to 35 (11.4 to 132.5)	3/4"
A-711T	Output sensor package	-	-

**SPECIFICATIONS**

**Service:** Compatible fluids.  
**Wetted Materials:** Body: Brass; Window: Tempered glass; Rotor: Red UV stabilized PBT; Rotor pin: 316 SS; Thrust washers: 300 series SS; Gasket: Buna-N.  
**Temperature Limits:** -20 to 200°F (-29 to 93°C).  
**Pressure Limits:** 125 psi (8.62 bar).  
**Viscosity Max:** 200 SSU.  
**Weight:** SFI only: 1.5 lb (0.7 kg); with A-711T: 1.8 lb (0.8 kg).

**ELECTRICAL SPECIFICATIONS**  
**Temperature Limits:** -20 to 212°F (-29 to 100°C).  
**Power Requirements:** 8-28 VDC.  
**Output Signal:** White lead: 5 VDC. Green lead: 8-28 VDC equal to supply voltage. Pulsed output with frequency rate proportional to flow rate.  
**Accuracy:** ±5% FS.  
**Frequency Output Range:** 0 to 100 Hz.  
**Mounting Orientation:** Horizontal.  
**Electrical Connections:** Black lead: Ground; White lead: 5 VDC out pulse; Green lead: 8-28 VDC out pulse; Red lead: 8-28 VDC supply.

++ USA: California Proposition 65  
 ⚠ WARNING: Cancer and Reproductive Harm  
 - www.P65Warnings.ca.gov





SERIES DFMT & DFMT2

# DIGITAL PADDLEWHEEL FLOW TRANSMITTERS

Flow and Total Indication, Easy to Read LCD Display, 4-20 mA or Pulse Output



DFMT



DFMT2

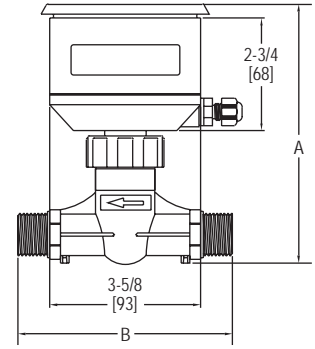
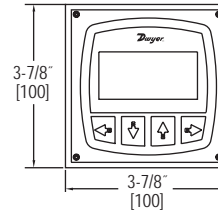
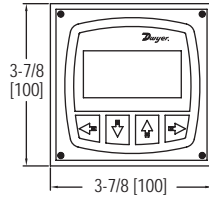

DFMT

Connection	A	B
3/8"	6" (152 mm)	4-3/4" (121 mm)
1/2"	6" (152 mm)	5-1/8" (130 mm)
3/4"	6-1/4" (158 mm)	5-5/8" (142 mm)
1"	6-1/4" (158 mm)	5-1/2" (141 mm)
1-1/2"	6-5/8" (168 mm)	6-7/8" (175 mm)
2"	7-1/4" (184 mm)	6-7/8" (175 mm)

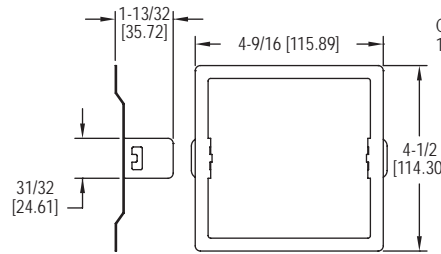

Remote mounting bracket (stainless steel)

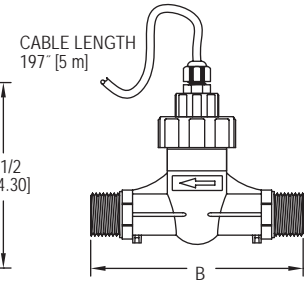

DFMT2

The Series DFMT Digital Paddlewheel Flow Transmitters provide instantaneous, as well as totalizing flow monitoring. The unit offers a user selectable 4-20 mA or pulse output with compact display.

**FEATURES/BENEFITS**

- The large backlit LCD display defines instantaneous as well as cumulative flow with visual indication bar designating percent of max flow
- Long operation life with high accuracy paddlewheel technology and corrosion resistant PVDF sensor
- Totalizer is user resettable at any time ideal for single batch totalization
- Security password protecting prevents any unauthorized changes

**APPLICATIONS**

- Cooling towers
- Chemical proportioning or blending
- Industrial water and wastewater treatment
- Cooling water monitoring
- Fluctuating fluid conductivity applications
- Reverse osmosis systems

The Series DFMT2 Remote Digital Paddlewheel Flow Transmitter provides instantaneous, as well as totalizing flow monitoring. The unit offers a user selectable 4 to 20 mA or pulse output with remote display.

**FEATURES/BENEFITS**

- Two piece design allows the user to separate the control display from the application, making it ideal in areas where space is limited
- The large backlit LCD display defines instantaneous as well as cumulative flow with visual indication bar designating percent of max flow
- Long operation life with high accuracy paddlewheel technology and corrosion resistant PVDF sensor
- Totalizer is user resettable at any time ideal for single batch totalization
- Security password protecting prevents any unauthorized changes

**APPLICATIONS**

- Reverse osmosis systems
- Remote flow monitoring
- Cooling towers
- Chemical proportioning or blending
- Industrial water & wastewater treatment
- Cooling water monitoring
- Fluctuating fluid conductivity applications

**SPECIFICATIONS**

**Service:** Compatible clean liquids.  
**Range:** See model chart.  
**Wetted Materials:** Sensor and impeller: PVDF; Shaft: Ceramic; O-rings: Fluoroelastomer.  
**Accuracy:** ±1.5% FS.  
**Repeatability:** ±0.5% FS.  
**Output:** Analog: 4-20 mA (750 Ω max. loop resistance); Pulse: NPN square wave output; Frequency: 0 to 2 kHz (adjustable); Pulse width: 0 to 1000 ms (adjustable).  
**Electrical Connections:** Removable screw terminal.  
**Temperature Limits:** Process: -4 to 194°F (-20 to 90°C); Ambient: -4 to 149°F (-20 to 65°C).  
**Pressure Limit:** 145 psi (1.0 MPa).  
**Power Requirements:** 12-24 VDC.  
**Power Consumption:** 2 W.  
**Display:** 2.38 x 1.25" (60.33 x 31.75 mm) LCD.  
**Totalizing Display Maximum:** 9,999,999,999.  
**Process Connection:** See model chart.  
**Enclosure Rating:** IP65.  
**Enclosure Material:** ABS plastic.  
**Weight:** See model chart.

Model	Range GPM (m³/h)	Connection	Weight lb (kg)
DFMT-10A	0.44 to 7.93 (0.1 to 1.8)	3/8" NPT	1.06 (0.48)
DFMT-15A	0.88 to 17.61 (0.2 to 4)	1/2" NPT	1.10 (0.5)
DFMT-20A	1.32 to 26.42 (0.3 to 6)	3/4" NPT	1.15 (0.52)
DFMT-25A	2.20 to 52.83 (0.5 to 12)	1" NPT	1.23 (0.56)
DFMT-40A	6.61 to 105.67 (1.5 to 24)	1-1/2" NPT	1.46 (0.66)
DFMT-50A	8.81 to 176.11 (2 to 40)	2" NPT	1.68 (0.76)

Model	Range GPM (m³/h)	Connection	Weight lb (kg)
DFMT2-10A	0.44 to 7.93 (0.1 to 1.8)	3/8" NPT	1.76 (0.8)
DFMT2-15A	0.88 to 17.61 (0.2 to 4)	1/2" NPT	1.81 (0.82)
DFMT2-20A	1.32 to 26.42 (0.3 to 6)	3/4" NPT	1.85 (0.84)
DFMT2-25A	2.20 to 52.83 (0.5 to 12)	1" NPT	1.94 (0.88)
DFMT2-40A	6.61 to 105.67 (1.5 to 24)	1-1/2" NPT	2.20 (1.0)
DFMT2-50A	8.81 to 176.11 (2 to 40)	2" NPT	2.43 (1.1)





# MULTI-JET HOT WATER METER

High Temperature Threshold, Pulsed Output

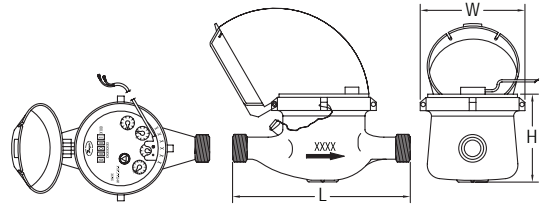

Size in (mm)	Spud NPSM (BSPP)	Length 'L' in (mm)	Width 'W' in (mm)	Height 'H' in (mm)	Weight lb (kg)
5/8 x 1/2 (15)	3/4" (3/4")	6-1/2(165)	3-45/64 (94)	4-15/64(107.5)	3.75(1.7)
5/8 x 3/4	1" (1")	7-1/2(190)	3-45/64(94)	4-15/64(107.5)	3.97(1.8)
3/4 (20)	1" (1")	7-1/2(190)	3-45/64(94)	4-15/64(107.5)	4.9(2.2)
1 (25)	1-1/4" (1-1/4")	10-1/4(260)	3-55/64(98)	4-5/8(117.5)	6.4(2.9)
1-1/4 (32)	1-1/2" (1-1/2")	10-1/4 (260)	3-55/64(98)	4-5/8(117.5)	8.2(3.7)
1-1/2 (40)	2" (2")	11-13/16 (300)	4-51/64(122)	5-9/16(141.5)	13.52 (6.17)
2 (50)	2-1/2" (2-1/2")	11-13/16 (300)	5-45/64(145)	6-31/32(177)	18.74 (8.5)

The **Series WMH Multi-Jet Hot Water Meter** is a series of mechanical, water totalizing meters that display the total water usage in gallons with m<sup>3</sup> options. They are available in a range of body sizes and include NPT or BSPT optional couplings. The high temperature resistant brass body is compatible in applications with high temperature water not suitable with standard brass water meters and maintains its accuracy.

### FEATURES/BENEFITS

- High temperature threshold of 190°F (88°C) ideal for high temperature applications
- Multi-jet design allows for simplicity and accuracy with wide flow ranges, even in low flow applications
- Magnetically driven, hermetically sealed register does not leak or fog and is completely separated from the water
- Designed for long service life and maintenance-free operation
- Integral strainer that protects meter from particulate damage
- Easy installation with included coupling adapters
- Pulsed output proportional to flow allows for remote flow totalization

### APPLICATIONS

- HVAC applications
- Measuring total condenser water flow in residential, commercial and industrial applications
- Remote hot water monitoring

### SPECIFICATIONS

**Service:** Water.  
**Wetted Materials:** Body: Brass; Couplings: Brass; Measuring Chamber: Brass.  
**Flow Range:** See model chart.  
**Accuracy:** WMH-A-X-XX: Transitional Flow: ±3%; Nominal Flow: ±1.5%.  
**Temperature Limit:** 190°F (88°C).  
**Pressure Limit:** 150 psi (10 bar).  
**Totalizing Display Maximum:** See model chart.  
**Output Signal:** Pulse output with frequency proportional to flow rate.  
**Pulse Options:** 0.1 gal, 1 gal, 10 gal, 100 gal per pulse (1 L, 10 L, 100 L, 1000 per pulse) See model chart.\*  
**Electrical Rating:** 0.01A @ 24VAC/DC.  
**Electrical Connections:** Color-coded lead wires, 4.5' (1.5 m) long.  
**Mounting Orientation:** Horizontal with register facing up.  
**Weight:** See dimension chart.

\*Consult factory for m<sup>3</sup>, BSPT units or additional pulse output options

### MODEL CHART

Model	Size	Coupling Size	GPM (Gallons Per Minute)			Display Max (Gallons)	Pulse Rate (Gal/Pulse)
			Max Flow	Nominal Flow Range	Transitional Flow		
WMH-A-C-01	5/8" x 1/2"	1/2" NPT	20	1 to 20	0.25	9,999,999.99	0.1
WMH-A-C-02	5/8" x 3/4"	3/4" NPT	20	1 to 20	0.25	9,999,999.99	0.1
WMH-A-C-03	3/4" SL	3/4" NPT	30	2 to 30	0.5	9,999,999.99	0.1
WMH-A-C-06	1"	1" NPT	50	3 to 50	0.75	9,999,999.99	0.1
WMH-A-C-01-1	5/8" x 1/2"	1/2" NPT	20	1 to 20	0.25	9,999,999.99	1
WMH-A-C-02-1	5/8" x 3/4"	3/4" NPT	20	1 to 20	0.25	9,999,999.99	1
WMH-A-C-03-1	3/4" SL	3/4" NPT	30	2 to 30	0.5	9,999,999.99	1
WMH-A-C-06-1	1"	1" NPT	50	3 to 50	0.75	9,999,999.99	1
WMH-A-C-07-1	1-1/2"	1-1/2" NPT	100	5 to 100	1.5	9,999,999.9	1
WMH-A-C-08-1	2"	2" NPT	160	8 to 160	2	9,999,999.9	1
WMH-A-C-01-10	5/8" x 1/2"	1/2" NPT	20	1 to 20	0.25	9,999,999.99	10
WMH-A-C-02-10	5/8" x 3/4"	3/4" NPT	20	1 to 20	0.25	9,999,999.99	10
WMH-A-C-03-10	3/4" SL	3/4" NPT	30	2 to 30	0.5	9,999,999.99	10
WMH-A-C-06-10	1"	1" NPT	50	3 to 50	0.75	9,999,999.99	10
WMH-A-C-07-10	1-1/2"	1-1/2" NPT	100	5 to 100	1.5	9,999,999.9	10
WMH-A-C-08-10	2"	2" NPT	160	8 to 160	2	9,999,999.9	10

USA: California Proposition 65

⚠ WARNING: Cancer an

Reproductive Harm

www.P65Warnings.ca.gov

## SERIES WNT

# MULTI-JET BRASS BODY WATER METER

NSF Certified, Lead Free, Economical

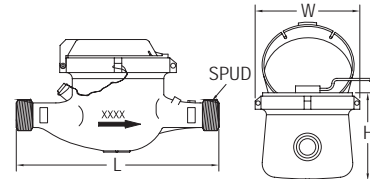

Size in (mm)	Spud NPSM (BSPP)	Length 'L' in (mm)	Width 'W' in (mm)	Height 'H' in (mm)	Weight lb (kg)
5/8 x 1/2 (15)	3/4" (3/4")	7-31/64(190)	3-45/64 (94)	4-15/64 (107.5)	3.58 (1.63)
5/8 x 3/4 (15)	1" (1")	7-31/64(190)	3-45/64 (94)	4-15/64 (107.5)	3.81 (1.73)
3/4 (20)	1" (1")	10-1/4 (260)	3-55/64 (98)	4-5/8 (117.5)	6.02 (2.73)
1 (25)	1-1/4" (1-1/4")	10-1/4(260)	3-55/64 (98)	4-5/8 (117.5)	6.02 (2.73)
1-1/2 (40)	2" (2")	11-13/16 (300)	4-51/64 (122)	4-5/8 (117.5)	12.02 (5.45)
2 (50)	2-1/2" (2-1/2")	11-13/16 (300)	5-45/64 (145)	5-9/16 (141.5)	13.23 (6)

The **Series WNT Multi-Jet Brass Body Water Meter** is a series of mechanical, water totalizing meters that display the total water usage in gallons or cubic meter. They are available in a range of body sizes and include NPT or BSPT couplings. Its lead free, NSF certified body is ideal for potable water applications.

### FEATURES/BENEFITS

- NSF/ANSI makes it ideal for no lead portable water requirements
- Multi-jet design allows for simplicity and accuracy with wide flow ranges, even in low flow applications
- Magnetically driven, hermetically sealed register does not leak or fog and is completely separated from the water
- Designed for long service life and maintenance-free operation
- Integral strainer that protects meter from particulate damage
- Easy installation with included coupling adapters
- Pulsed output proportional to flow allows for remote flow totalization

### APPLICATIONS

- Potable water applications
- Residential water measurement
- Remote water monitoring

### SPECIFICATIONS

**Service:** Water.  
**Wetted Materials:** Body: ECO BRASS®; Couplings: ECO BRASS®; Measuring chamber: ABS Plastic.  
**Flow Range:** See model chart.  
**Accuracy:** Transitional Flow: ±3%; Nominal Flow: ±1.5%.  
**Temperature Limit:** 122°F (50° C).  
**Pressure Limit:** 150 psi (10 bar).  
**Totalizing Display Maximum:** See model chart.  
**Output Signal:** Pulse output with frequency proportional to flow rate.  
**Pulse Options:** 0.1 gal, 1 gal, 10 gal, 100 gal per pulse.  
**Electrical Rating:** 0.01 A @ 24 VAC/DC.  
**Electrical Connections:** Color-coded lead wires, 4.5' (1.5 m) long.  
**Mounting Orientation:** Horizontal with register facing up.  
**Agency Approvals:** NSF.

### MODEL CHART

Model	Size	Coupling Size	GPM (Gallons Per Minute)			Display Max (Gallons)	Pulse Rate (Gal/Pulse)
			Max Flow	Nominal Flow Range	Transitional Flow		
WNT-A-C-01	5/8" x 1/2"	1/2" NPT	20	1 to 20	0.25	9,999,999.99	0.1
WNT-A-C-02	5/8" x 3/4"	3/4" NPT	20	1 to 20	0.25	9,999,999.99	0.1
WNT-A-C-05	3/4" x 1"	1" NPT	30	2 to 30	0.5	9,999,999.99	0.1
WNT-A-C-06	1"	1" NPT	50	3 to 50	0.75	9,999,999.99	0.1
WNT-A-C-07-1	1-1/2"	1-1/2" NPT	100	5 to 100	1.25	9,999,999.9	1
WNT-A-C-08-1	2"	2" NPT	160	8 to 160	2	9,999,999.9	1

⚠ WARNING: Cancer and Reproductive Harm - www.P65Warnings.ca.gov

ECO BRASS® is a registered trademark patent by Mitsubishi Shindoh



SERIES WM2 & WMT2

# MULTI-JET WATER METER

Economical, Brass Body, Dry Dial

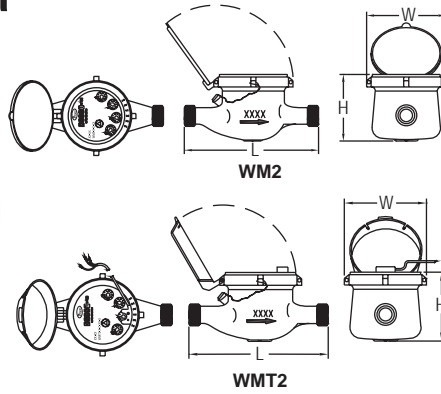

Size in (mm)	Spud NPSM (BSPP)	Length 'L' in (mm)	Width 'W' in (mm)	Height 'H' in (mm)	Weight lb (kg)
5/8 x 1/2 (15)	3/4" (3/4")	6-1/2 (165)	3-45/64 (94)	4-15/64 (107.5)	3.75 (1.7)
5/8 x 3/4	1" (1")	7-1/2 (190)	3-45/64 (94)	4-15/64 (107.5)	3.97 (1.8)
3/4 (20)	1" (1")	7-1/2 (190)	3-45/64 (94)	4-15/64 (107.5)	4.9 (2.2)
1 (25)	1-1/4" (1-1/4")	10-1/4 (260)	3-55/64 (98)	4-5/8 (117.5)	6.4 (2.9)
1-1/4 (32)	1-1/2" (1-1/2")	10-1/4 (260)	3-55/64 (98)	4-5/8 (117.5)	8.2 (3.7)
1-1/2 (40)	2" (2")	11-13/16 (300)	4-51/64 (122)	5-9/16 (141.5)	13.52 (6.17)
2 (50)	2-1/2" (2-1/2")	11-13/16 (300)	5-45/64 (145)	6-31/32 (177)	18.74 (8.5)

The Series WM2 Multi-Jet Water Meter is a series of mechanical, water totalizing meters that display the total water usage in gallons or m<sup>3</sup>. They are available in a range of body sizes and include NPT or BSPT couplings. The Series WMT2 Multi-Jet Water Meter with Pulsed Output is a series of mechanical, water totalizing meters that display the total water usage in gallons or m<sup>3</sup> and provide a reed switch output proportional to flow rate. They are available in a range of body sizes and include NPT or BSPT couplings.

**FEATURES/BENEFITS**

- Multi-jet design allows for simplicity and accuracy with wide flow ranges, even in low flow applications
- Magnetically driven, hermetically sealed register does not leak or fog and is completely separated from the water
- Designed for long service life and maintenance-free operation, even under harsh conditions
- Integral strainer that protects meter from particulate damage
- Easy installation with included coupling adapters

**APPLICATIONS**

- Irrigation
- Cooling systems
- Filtration systems
- Water monitoring

**SPECIFICATIONS**

**Service:** Water.  
**Wetted Materials:** Body: Brass, polyethylene; Couplings: Brass; Measuring Chamber: Polyethylene, ABS plastic, ferrite, acetal.  
**Flow Range:** See model chart.  
**Accuracy:** Transitional flow: ±5%; Nominal flow: ±2%.  
**Temperature Limit:** 104°F (40°C).  
**Pressure Limit:** 232 psi (16 bar).  
**Totalizing Display Maximum:** See model chart.  
**Output Signal:** Pulse output with frequency proportional to flow rate (WMT2 only).  
**Pulse Options:** 0.1 gal, 1 gal, 10 gal, 100 gal per pulse (1 L, 10 L, 100 L per pulse) (WMT2 only).  
**Electrical Rating:** 0.01 A @ 24 VAC/DC (WMT2 only).  
**Electrical Connections:** Color-coded lead wires, 4.5' (1.5 m) long (WMT2 only).  
**Mounting Orientation:** Horizontal with the register face pointing up.  
**Weight:** See dimension chart.

MODEL CHART						
Model	Size	Coupling Size	Max Flow GPM (Gallons Per Minute)	Nominal Flow Range	Transitional Flow	Display Max (Gallons)
WM2-A-C-01	5/8 x 1/2"	1/2" NPT	20	1 to 20	0.25	9,999,999.99
WM2-A-C-02	5/8 x 3/4"	3/4" NPT	20	1 to 20	0.25	9,999,999.99
WM2-A-C-03	3/4"	3/4" NPT	30	2 to 30	0.5	99,999,999.9
WM2-A-C-04	1"	1" NPT	50	3 to 50	0.75	99,999,999.9
WM2-A-C-06	1-1/2"	1-1/2" NPT	100	5 to 100	1.5	99,999,999.9
WM2-A-C-07	2"	2" NPT	160	8 to 160	2	99,999,999.9

MODEL CHART						
Model	Size	Coupling Size	Max Flow m <sup>3</sup> /h	Nominal Flow Range	Transitional Flow	Display Max (m <sup>3</sup> )
WM2-B-C-08	15 mm	1/2" BSPT	3	0.12 to 1.5	0.03	99,999.9999
WM2-B-C-10	20 mm	3/4" BSPT	5	0.2 to 2.5	0.05	99,999.9999
WM2-B-C-11	25 mm	1" BSPT	7	0.28 to 3.5	0.07	99,999.9999
WM2-B-C-12	32 mm	1-1/4" BSPT	12	0.48 to 6	0.12	99,999.9999
WM2-B-C-13	40 mm	1-1/2" BSPT	20	0.8 to 10	0.2	999,999.9999
WM2-B-C-14	50 mm	2" BSPT	30	1.2 to 15	0.3	999,999.9999

MODEL CHART							
Model	Size	Coupling Size	Max Flow GPM (Gallons Per Minute)	Nominal Flow Range	Transitional Flow	Display Max (Gallons)	Pulse Rate (Gal./Pulse)
WMT2-A-C-01	5/8 x 1/2"	1/2" NPT	20	1 to 10	0.25	9,999,999.99	0.1
WMT2-A-C-02	5/8 x 3/4"	3/4" NPT	20	1 to 20	0.25	9,999,999.99	0.1
WMT2-A-C-03*	3/4"	3/4" NPT	30	2 to 30	0.25	9,999,999.99	0.1
WMT2-A-C-04	1"	1" NPT	50	3 to 50	0.75	99,999,999.9	0.1
WMT2-A-C-01-1	5/8 x 1/2"	1/2" NPT	20	1 to 10	0.25	9,999,999.99	1
WMT2-A-C-02-1	5/8 x 3/4"	3/4" NPT	20	1 to 20	0.25	9,999,999.99	1
WMT2-A-C-03-1*	3/4"	3/4" NPT	30	2 to 30	0.25	9,999,999.99	1
WMT2-A-C-04-1	1"	1" NPT	50	3 to 50	0.75	99,999,999.9	1
WMT2-A-C-06-10	1-1/2"	1-1/2" NPT	100	5 to 100	1.5	99,999,999.9	10
WMT2-A-C-07-10	2"	2" NPT	160	8 to 160	2	99,999,999.9	10
WMT2-A-C-04-100	1"	1" NPT	50	3 to 50	0.75	99,999,999.9	100
WMT2-A-C-07-100	2"	2" NPT	160	8 to 160	2	99,999,999.9	100

\*Does not include inlet filter.

MODEL CHART							
Model	Size	Coupling Size	Max Flow m <sup>3</sup> /h	Nominal Flow Range	Transitional Flow	Display Max (m <sup>3</sup> /h)	Pulse Rate (L/Pulse)
WMT2-B-C-08-1	15 mm	1/2" BSPT	3	0.12 to 1.5	0.03	99,999.9999	1
WMT2-B-C-10-1*	20 mm	3/4" BSPT	5	0.2 to 2.5	0.05	99,999.9999	1
WMT2-B-C-11-1	25 mm	1" BSPT	7	0.25 to 3.5	0.07	99,999.9999	1
WMT2-B-C-12-1	32 mm	1-1/4" BSPT	12	0.48 to 6	0.12	99,999.9999	1
WMT2-B-C-08-10	15 mm	1/2" BSPT	3	0.12 to 1.5	0.03	99,999.9999	10
WMT2-B-C-12-10	32 mm	1-1/4" BSPT	12	0.48 to 6	0.12	99,999.9999	10
WMT2-B-C-14-10	50 mm	2" BSPT	30	1.2 to 15	0.3	999,999.9999	10
WMT2-B-C-12-100	32 mm	1-1/4" BSPT	12	0.48 to 6	0.12	99,999.9999	100
WMT2-B-C-14-100	50 mm	2" BSPT	30	1.2 to 15	0.3	999,999.9999	100

\*Does not include inlet filter.

USA: California Proposition 65

⚠ WARNING: Cancer and Reproductive Harm - www.P65Warnings.ca.gov

# MULTI-JET PLASTIC WATER METER

Lead Free, Economical Plastic Body, Pulse Output

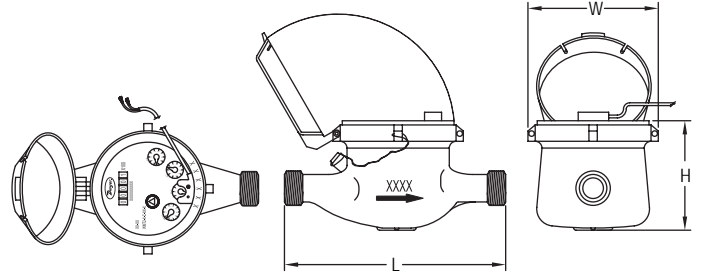

Size in (mm)	Spud NPSM (BSPP)	Length 'L' in (mm)	Width 'W' in (mm)	Height 'H' in (mm)	Weight lb (kg)
5/8 x 1/2 (15)	3/4" (3/4")	6-1/2(165)	3-23/32 (94)	4-15/64 (107.5)	1.55 (0.7)
5/8 x 3/4	1" (1")	7-1/2(190)	3-23/32 (94)	4-15/64 (107.5)	1.77 (0.8)
3/4 x 1 (20)	1-1/4" (1-1/4")	10-1/4 (260)	3-23/32 (94)	4-15/64 (107.5)	2.43 (1.1)
1 (25)	1-1/4" (1-1/4")	10-1/4(260)	3-23/32 (94)	4-15/64 (107.5)	2.43 (1.1)
1-1/2 (40)	2" (2")	9-5/8 (245)	4-13/16 (122)	5-45/64 (141.5)	4.41 (2)



The Series WPT Multi-Jet Plastic Water Meter is a series of mechanical, water totalizing meters that display the total water usage in gallons with m<sup>3</sup> options. They are available in a range of body sizes and include NPT or BSPT optional couplings. The plastic body water meters can be used in potable water applications, some corrosive environments, or where an economical water totalizer is desired.

### FEATURES/BENEFITS

- Plastic body ideal for lead free requirements
- Multi-jet design allows for simplicity and accuracy with wide flow ranges, even in low flow applications
- Magnetically driven, hermetically sealed register does not leak or fog and is completely separated from the water
- Designed for long service life and maintenance-free operation
- Integral strainer that protects meter from particulate damage
- Easy installation with included coupling adapters
- Pulsed output proportional to flow allows for remote flow totalization

### APPLICATIONS

- Low cost residential water measurement
- Agriculture (fertilizers, pesticides, and herbicides)
- Irrigation
- Remote water monitoring

### MODEL CHART

Model	Size	Coupling Size	GPM (Gallons Per Minute)			Display Max (Gallons)	Pulse Rate (Gal/Pulse)
			Max Flow	Nominal Flow Range	Transitional Flow		
WPT-A-C-01	5/8" x 1/2"	1/2" NPT	20	1 to 20	0.25	9,999,999.99	0.1
WPT-A-C-02	5/8" x 3/4"	3/4" NPT	20	1 to 20	0.25	9,999,999.99	0.1
WPT-A-C-03	3/4" x 1"	1" NPT	30	2 to 30	0.5	9,999,999.99	0.1
WPT-A-C-04	1"	1" NPT	50	3 to 50	0.75	9,999,999.99	0.1
WPT-A-C-01-1	1/2"	1/2" NPT	20	1 to 20	0.25	9,999,999.99	1
WPT-A-C-02-1	5/8" x 3/4"	3/4" NPT	20	1 to 20	0.25	9,999,999.99	1
WPT-A-C-03-1	3/4" x 1"	1" NPT	30	2 to 30	0.5	9,999,999.99	1
WPT-A-C-04-1	1"	1" NPT	50	3 to 50	0.75	9,999,999.99	1
WPT-A-C-05-1	1-1/2"	1-1/2" NPT	100	5 to 100	1.5	9,999,999.9	1
WPT-A-C-01-10	1/2"	1/2" NPT	20	1 to 20	0.25	9,999,999.99	10
WPT-A-C-02-10	5/8" x 3/4"	3/4" NPT	20	1 to 20	0.25	9,999,999.99	10
WPT-A-C-03-10	3/4" x 1"	1" NPT	30	2 to 30	0.5	9,999,999.99	10
WPT-A-C-04-10	1"	1" NPT	50	3 to 50	0.75	9,999,999.99	10
WPT-A-C-05-10	1-1/2"	1-1/2" NPT	100	5 to 100	1.5	9,999,999.9	10

### SPECIFICATIONS

**Service:** Water.  
**Wetted Materials:** Body: Nylon 66; Couplings: Nylon 66, 1-1/2" (40 mm) sizes lead free ECO BRASS® alloy; Measuring Chamber: ABS Plastic.  
**Flow Range:** See model chart.  
**Accuracy:** WPT-A-X-XX: Transitional Flow: ±3%; Nominal Flow: ±1.5%.  
**Temperature Limit:** 122°F (50°C).  
**Pressure Limit:** 150 psi (10 bar).  
**Totalizing Display Maximum:** See model chart.  
**Output Signal:** Pulse output with frequency proportional to flow rate.  
**Pulse Options:** 0.1 gal, 1 gal, 10 gal, 100 gal per pulse (1 L, 10 L, 100 L, 1000 per pulse) See model chart.\*  
**Electrical Rating:** 0.01 A @ 24 VAC/DC.  
**Electrical Connections:** Color-coded lead wires, 4.5' (1.5 m) long.  
**Mounting Orientation:** Horizontal with register facing up.  
**Weight:** See dimension chart.  
 \*Consult factory for m<sup>3</sup>, BSPT units or additional pulse output options

USA: California Proposition 65  
 ⚠WARNING: Cancer and Reproductive Harm - www.P65Warnings.ca.gov

ECO BRASS® is a registered mark patented by Mitsubishi Shindoh

Distributed by: M&M Control Service, Inc. | <https://www.mmcontrol.com/Dwyer.php> | 800-876-0036  
 847-356-0566 **287**



SERIES UFB & UFC



# ULTRASONIC FLOWMETER SETS

Non-Invasive Pipe Flow Measurement, Easy Operation and Data Logging Option



UFB



UFC

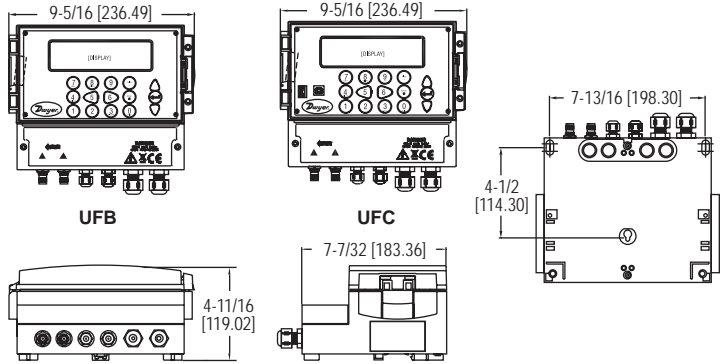

The Series UFB & UFC Ultrasonic Flowmeter Sets utilize the transit-time difference for measuring flow rates in pipes. These units are permanent mount, where the converters can be mounted on a surface or pipe with a 4-20 mA and pulse output capabilities for pipe sizes from 1/2 to 79" (13 to 2000 mm). The Series UFC offers the same features plus data logging capability.

**FEATURES/BENEFITS**

- Non-invasive pipe measurement
- Easy-to-use compact and lightweight design, intended for homogeneous liquids that contain no air
- Simple installation with all necessary components included such as converter, sensor, cables and mounting accessories
- Sturdy IP65 rating, protecting it from dust and direct water contact

**APPLICATIONS**

- Water treatment
- Industrial systems
- Irrigation applications
- Treated water flow
- River water
- Sea water
- Potable water
- Demineralized water
- Glycol/water mix
- Hydraulic system
- Diesel oil
- Water use data logging

**KIT INCLUDES**

- Converter
- Set of transducers
- Ruled guide rail
- Steel banding
- Banding clips
- Set of transducer cables
- Set of high temperature interface cables
- Ultrasonic coupling grease

**MODEL CHART - STANDARD VERSION**

Model	Pipe Size Range in (mm)	Power Supply
UFB-122	0.5 to 4.5 (13 to 115)	86-264 VAC
UFB-123	2 to 79 (50 to 2000)	86-264 VAC
UFB-222	0.5 to 4.5 (13 to 115)	24 VAC/VDC
UFB-223	2 to 79 (50 to 2000)	24 VAC/VDC

**MODEL CHART - DATA LOGGING VERSION**

Model	Pipe Size Range in (mm)	Power Supply
UFC-122	0.5 to 4.5 (13 to 115)	86-264 VAC
UFC-123	2 to 79 (50 to 2000)	86-264 VAC
UFC-222	0.5 to 4.5 (13 to 115)	24 VDC/VAC
UFC-223	2 to 79 (50 to 2000)	24 VDC/VAC

**SPECIFICATIONS**

**Service:** Homogeneous liquids that do not contain more than 3% of air bubbles or particulate and capable of ultrasonic wave propagation.  
**Inputs:** TNC cable from sensors.  
**Range:** 0.33 to 33 ft/s (0.1 to 10 m/s).  
**Display:** 240 x 64 pixel graphic display, high contrast black on white with backlight; Languages: English, French, German, Swedish, Italian, Spanish, Portuguese, Russian, Norwegian, and Dutch; 5" W x 1.3" H (5 x 33.02 mm).  
**Accuracy:** ±0.5 to ±2% of flow reading of flow rate > 0.03 ft/s (0.01 m/s) and pipe OD > 3.0 in (75 mm); ±3% of flow reading for flow rate > 0.03 ft/s (0.01 m/s) and pipe OD 0.5 to 3 in (13 to 75 mm); ±6% of flow reading for flow rate < 0.03 ft/s (0.01 m/s).  
**Power Requirements:** 86-264 VAC (50 to 60 Hz) or 24 VAC/VDC (1 A max).  
**Power Consumption:** 10.5 W.  
**Temperature Limits:** Transducer: -4 to 275°F (-20 to 135°C); Controller: -4 to 122°F (-20 to 50°C).  
**Outputs:** Analog 1 opto-isolated output: 4-20 mA, 0-16 mA or 0-20 mA (selectable); Error current: 0-26 mA (selectable); Load resistance: 620 Ω max; Alarm: 2 opto-isolated MOSFET NO relays, 48 V at 500 mA, maximum 200 Hz; Pulsed: 1 opto-isolated MOSFET relay, 48 V at 500 mA, 1 to 250 pps; Pulse width: 2 to 500 ms (selectable).  
**Serial Communications:** USB (UFC only).  
**Enclosure Rating:** IP65 when using TNC connector; Transducers IP54.  
**Materials:** Plastic ABS and aluminum.  
**Repeatability:** ±0.5 % of measured value or 0.03 ft/s (0.01 m/s).  
**Electrical Connections:** Removable screw-in type terminal block.  
**Mounting:** Wall mounted using 3 type M4 screws.  
**Turbidity:** < 3 % by volume of particulate content.  
**Permissible Air Content:** < 3% by volume.  
**Response Time:** < 500 ms.  
**Weight:** Unit not including accessories: 2.80 lb (1.26 kg); Unit including accessories: 9.92 lb (4.5 kg).  
**Agency Approvals:** CE.

**ADDITIONAL SPECIFICATIONS**

**Applicable Pipe Material:** Carbon steel, SS, copper, UPVC/PVDF, concrete, mild steel, glass, brass.  
**Applicable Pipe Lining:** Rubber, glass, concrete, epoxy, steel, other\*.  
**Pipe Wall Thickness:** 0.04 to 3" (1 to 75 mm).  
**Pipe Lining Thickness:** < 1" (< 25 mm).  
 \*Selectable option for special material with known propagation rate of lining material.

**OPTIONS**

Use order code:	Description
NISTCAL-FU	NIST traceable calibration certificate

USA: California Proposition 65  
 ⚠WARNING: Cancer and Reproductive Harm - www.P65Warnings.ca.gov



# COMPACT ULTRASONIC FLOWMETERS

Cost Effective, Compact and Adjustable Design, Non-Invasive

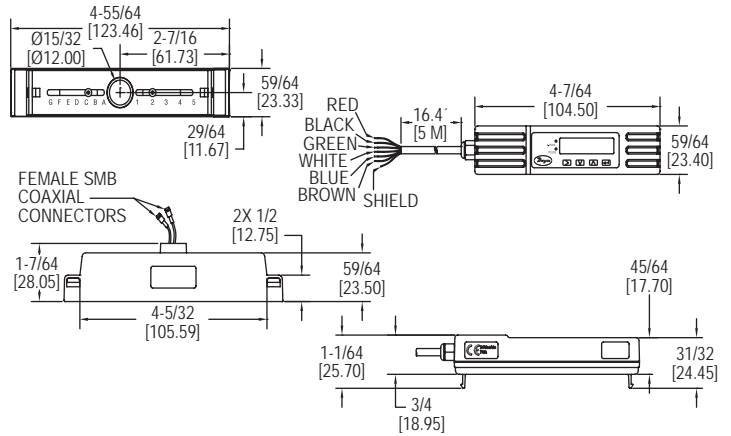

The Model UFM Compact Ultrasonic Flowmeters are economical, clamp-on, ultrasonic flowmeter. The Model UFM implements the transit-time difference to measure flow rates in pipes and can measure velocity and flow in pipes with outside diameters ranging from 0.98 to 4.62" (24.89 to 117.35 mm). This model comes with a volume pulse and 4-20 mA flow rate output.

### FEATURES/BENEFITS

- Non-invasive pipe measurement
- Simple installation with all necessary components included such as converter, sensor, cables and mounting accessories
- Compact and lightweight design, featuring an easily installed, all in one clamp-on unit intended for homogeneous liquids that contain no air
- Screen offers easy to read text displaying both flow rate and total with a convenient backlight for visual comfort

### APPLICATIONS

- Flow measurement for heat metering
- Chilled water metering and monitoring
- Potable water metering and monitoring
- Process water metering and monitoring

### KIT INCLUDES

- Converter with adjustable guiderail
- Set of 1.81 to 2.75" (46 to 70 mm) clamps
- Set of 2 to 5" (51 to 127 mm) clamps
- Set of small pipe adaptor V clamps
- Set of small pipe adaptor V clamps
- Ultrasonic coupling grease

MODEL CHART	
Model	Description
UFM-1	Compact ultrasonic flowmeter

### SPECIFICATIONS

**Service:** Clean water with < 3% by volume of particulate content.  
**Range:** 0.33 to 32.8 ft/s (0.1 to 10 m/s).  
**Display:** Backlit: 3.27" H x 0.74" W (83.1 mm x 18.8 mm), 2 line x 16 characters.  
**Accuracy:** ±3% of flow reading for > 0.98 ft/s (> 0.3 m/s).  
**Power Requirements:** 12-24 VDC or VAC.  
**Power Consumption:** 7 W max.  
**Temperature Limits:** Process: 32 to 185°F (0 to 85°C); Ambient: 32 to 122°F (0 to 50°C).  
**Outputs:** Analog: 1 opto-isolated: 4 to 20 mA; Error current: 3.5 mA; Load resistance: 620 Ω max; Pulse: 1 opto-isolated MOSFET relay, 500 mA max, 166 pps max, 200 Hz max.

**Enclosure Rating:** IP54.  
**Enclosure Material:** Plastic polycarbonate.  
**Repeatability:** ±0.5% of measured value.  
**Electrical Connections:** 16.4' (5 m) cable.  
**Response Time:** < 1 s.  
**Weight:** 2.9 lb (1.315 kg).  
**Agency Approvals:** CE.

### ADDITIONAL SPECIFICATIONS

**Applicable Pipe Material:** Steel, copper, or plastic.  
**Pipe Outside Diameter:** 0.98 to 4.62" (24.89 to 117.35 mm).  
**Applicable Pipe Lining:** None.  
**Pipe Wall Thickness:** 0.02 to 0.39" (0.5 to 10 mm).

### OPTIONS

Use order code:	Description
NISTCAL-FU	NIST traceable calibration certificate

USA: California Proposition 65

⚠WARNING: Cancer and Reproductive Harm - www.P65Warnings.ca.gov

## MODEL UTG

# ULTRASONIC THICKNESS GAGE

Ideal For Use with Ultrasonic Flow Transmitters, Adjustable Sound Velocity

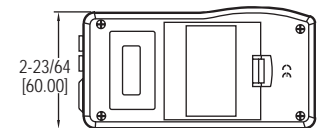
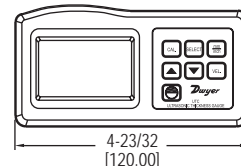
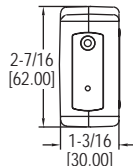

The Model UTG Ultrasonic Thickness Gage measures the thickness of a variety of materials. The UTG works on a variety of parallel surface material ranging from 0.05 to 7.9" (1.2 to 200 mm).

### FEATURES/BENEFITS

- Non-invasive thickness measurement
- Reads in inches or millimeters and features an adjustable sound velocity to allow for an array of materials to be measured
- Allows the user to find the wall thickness of the pipe when programming an ultrasonic transmitter without cutting or removing a section of the pipe to measure it
- Ideal for monitoring corrosion in closed vessels such as boilers and chemical tanks and with any ultrasonic flow transmitter

### APPLICATIONS

- Pipe thickness measurement
- Finding wall thickness
- Monitoring corrosion in closed vessels
- Industrial applications
- Automotive
- HVAC
- Plumbing

### SPECIFICATIONS

**Service:** Steel, cast iron, aluminum, red copper, brass, zinc, quartz glass, polyethylene, PVC, gray cast iron, nodular cast iron, other. Selectable option for special materials with known sound propagation rate.\*  
**Range:** 0.047 to 7.874" (1.2 to 200 mm).  
**Accuracy:** ±0.5%.  
**Resolution:** 0.001" / 0.1 mm.

**Sound Velocity:** 1118 to 20132 mph (500 to 9000 m/s).  
**Temperature Limits:** 32 to 122°F (0 to 50°C).  
**Humidity Limit:** < 80%.  
**Display:** 4 digits, 0.394" (10 mm) LCD.  
**Power Requirement:** (4) 1.5 V AAA alkaline batteries, not included, user replaceable.  
**Weight:** 5.78 oz (164 g).

\*Material must be uniform with minimal coating/paint.

### MODEL CHART

Model	Description
UTG	Ultrasonic thickness gage

USA: California Proposition 65

⚠WARNING: Cancer and Reproductive Harm - www.P65Warnings.ca.gov

# PORTABLE ULTRASONIC FLOWMETER KITS

Portable, Non-Invasive and Data Logging Option



PUB



PUF

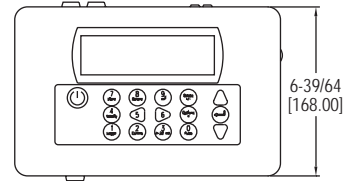

The Series PUB & PUF Portable Ultrasonic Flowmeter Kits utilize the transit-time difference for measuring flow rates in pipes non-invasively. Units offer flow rate local display with analog and pulsed outputs. The Series PUF offers the same features plus data logging capability.

**FEATURES/BENEFITS**

- Non-invasive pipe measurement
- Compact and lightweight
- Incorporate the latest electronics and signal processing technologies realizing high performance and easy operation
- Ideal for on-the-go flow monitoring, capable of 20 hours continuous operation with built-in, rechargeable battery
- Easy to read graphic display with convenient backlight for visual comfort
- Efficient layout of the function keys for easy to use programming
- PUB features rugged carrying case with molded foam inserts
- PUF boasts an IP67 rated case to hold and protect all equipment conveniently

**APPLICATIONS**

- Water treatment
- Industrial systems
- Irrigation applications
- Treated water flow
- River water
- Sea water
- Potable water
- Demineralized water
- Glycol/water mix
- Hydraulic system
- Diesel oil
- Water use data logging

**KIT INCLUDES**

- Converter
- Set of transducers
- Transducer holders
- Set of transducer cables (6.56' (2 m))
- 4-20 mA communication cables
- 12 VDC power supply
- Ultrasonic coupling grease
- Set of chains
- Ruled guide rail
- Test block
- Carrying case

MODEL CHART - STANDARD VERSION	
Model	Pipe Size Range in (mm)
PUB-10	0.5 to 4.5 (13 to 115)
PUB-20	2 to 40 (50.7 to 1016)

MODEL CHART - DATA LOGGING VERSION	
Model	Pipe Size Range in (mm)
PUF-1001	0.5 to 78 (13 to 2000)
PUF-1002	0.5 to 4.5 (13 to 115)
PUF-1003	2 to 78 (50 to 2000)

**SPECIFICATIONS**

**Service:** Homogeneous liquids that do not contain air bubbles capable of ultrasonic wave propagation.  
**Inputs:** Lemo connector cable from sensors.  
**Range:** 0.33 to 65.62 ft/s (0.1 to 20 m/s).  
**Display:** 240 x 64 pixel graphic display, high contrast black on white with backlight; Languages: English, French, German, Swedish, Italian, Spanish, Portuguese, Russian, Norwegian, and Dutch; 5.2" W x 1.5" H.  
**Accuracy:** ±0.5 to 2% of flow reading for flow rate > 0.66 ft/s (0.2 m/s) and pipe ID > 2.95 in (75 mm); ±3% of flow reading for flow rate > 0.66 ft/s (0.2 m/s) and pipe ID in range 0.512 to 2.95" (13 to 75 mm); ±6% of flow reading for flow rate < 0.66 ft/s (0.2 m/s).  
**Power Requirements:** 9-24 VDC, (1) 5-Cell NiMH battery, internal, factory replaceable (continuous operation time: 20 hours with back-light and output off) (recharging time: 6.5 hours, power adapter used).  
**Power Consumption:** 10.5 W.  
**Power Adapter:** 110/240 VAC adapter. UK, US, European adapters included.  
**Temperature Limits:** -4 to 275°F (-20 to 135°C).  
**Outputs:** Analog: 1 opto-isolated output: 4-20 mA, 0-16 mA or 0-20 mA (selectable); Error current: 0-26 mA (selectable); Load resistance: 620 Ω max; Pulse: 1 opto-isolated MOSFET relay, 150 mA max, 500 pps max, 200 Hz max.  
**Serial Communications:** USB; RS-232 (PUF only).  
**Enclosure Rating:** Converter: IP54; Transducers: IP51.  
**Materials:** Flame retardant injection molded ABS plastic.  
**Repeatability:** ±0.5 % of measured value or ±0.066 ft/s (0.02 m/s).  
**Electrical Connections:** Multi-pin Lemo plugs.  
**Turbidity:** < 3% by volume of particulate content.  
**Permissible Air Content:** < 3% by volume.  
**Response Time:** < 500 ms.  
**Weight:** Unit without accessories: 2.3 lb (1.06 kg); Unit with accessories in carrying case: 13.23 lb (6.0 kg).  
**Agency Approvals:** CE.

**ADDITIONAL SPECIFICATIONS**

**Applicable Pipe Material:** Carbon steel, SS, copper, UPVC/PVDF, concrete, galvanized steel, mild steel, glass, brass.  
**Applicable Pipe Lining:** Rubber, glass, concrete, epoxy, steel, other\*.  
**Pipe Wall Thickness:** 0.04 to 3" (1 to 75 mm).  
**Pipe Lining Thickness:** < 1" (< 25 mm).

\*Selectable option for special material with known propagation rate of lining material.

OPTIONS	
Use order code:	Description
NISTCAL-FU	NIST traceable calibration certificate

USA: California Proposition 65  
 ⚠WARNING: Cancer and Reproductive Harm - www.P65Warnings.ca.gov

# MAGNETIC INDUCTIVE FLOW SENSORS

No Moving Parts, Frequency and 4-20 mA Output, Maintenance-Free



MFS

Model	L1	L2	D1	D2
MFS2-1	4"	0.86"	1/2-14" NPT	0.31"
MFS2-2	4"	0.86"	1/2-14" NPT	0.31"
MFS2-3	4.02"	0.86"	3/4-14" NPT	0.55"
MFS2-4	4.41"	1.04"	1-11.5" NPT	0.71"
MFS2-5	4.41"	1.04"	1-11.5" NPT	0.71"
MFS2-6	4.81"	1.13"	1-1/4-11.5" NPT	0.98"

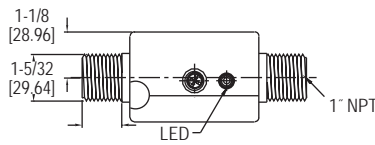

MFS-31 & MFS-32

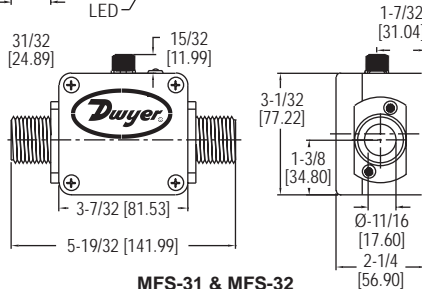

MFS-11 & MFS-12  
MFS-21 & MFS-22



MFS2

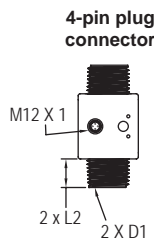

MFS2-6

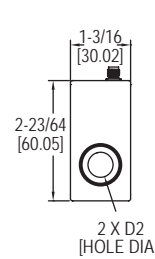

MFS2-1/5

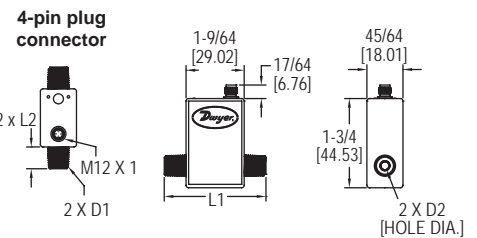

The **Series MFS & MFS2 Magnetic Inductive Flow Sensors** are compact, 316 SS body, in line flowmeters with pulse and optional analog 4-20 mA output. It is available in a variety of flow ranges from 0.25 to 52.8 GPM (1 to 200 LPM) and process connection sizes of 1/2" and 1" NPT.

**FEATURES/BENEFITS**

- Long life cycle with no moving parts to wear or break
- Can be applied in applications dealing with contaminated media with no mechanical component in the flow
- Obstruction free pipe cross-section yields low pressure drop
- Unaffected by change in temperature, density, viscosity or concentration

**APPLICATIONS**

- Contaminated liquid flow monitoring
- Flow of conductive liquids
- Water & wastewater treatment
- Industrial systems
- Irrigation applications

**SPECIFICATIONS**

**Service:** Compatible, non-coating, conductive liquids.  
**Range:** See model chart.  
**Wetted Materials:** Electrodes: 316 SS; Process connections: MFS: 316 SS; MFS2: PVDF; Measuring pipe: MFS: PEEK-GF30; Gasket: EPDM.  
**Accuracy:** MFS: ±2% of reading; MFS2: ±1% or reading.  
**Repeatability:** 1%.  
**Temperature Limits:** MFS: Process: 32 to 194°F (0 to 90°C); Ambient: 41 to 158°F (5 to 70°C); MFS2: Process: 14 to 140°F (-10 to 60°C); Ambient: 41 to 140°F (5 to 60°C).  
**Pressure Limits:** MFS: 232 psi (16 bar); MFS2: 145 psi (10 bar) @ 68°F (20°C); 116 psi (8 bar) @ 104°F (40°C); 87 psi (6 bar) @ 140°F (60°C).  
**Response Time:** MFS: < 500 ms; MFS2: < 100 ms.

**Power Requirements:** 24 VDC ±10%.  
**Power Consumption:** 0.6 W.  
**Output: Frequency:** Square-wave, NPN or PNP; Analog: 4-20 mA.  
**Loop Resistance:** 250 Ω.  
**Current Consumption:** Max 80 mA.  
**Minimum Conductivity of Medium:** 50 µS/cm.  
**Flow Indication:** LED green, flow proportional blinking.  
**Enclosure Rating:** NEMA 4 (IP65).  
**Process Connection:** See model chart.  
**Electrical Connection:** Plug connector M12x1.  
**Weight:** MFS-1X: 1.5 lb (0.68 kg); MFS-2X: 1.7 lb (0.77 kg); MFS-3X: 1.9 lb (0.87 kg); MFS2-1, -2, -3, -4, -5: 8 oz (226.8 g); MFS2-6: 1 lb (0.45 kg).

MODEL CHART				
Model	Range GPM (LPM)	Minimum Output Signal GPM (LPM)	Process Connection	Output
MFS-11	0.25 to 5.3 (1 to 20)	0.13 (0.5)	1/2" NPT	Frequency
MFS-21	0.5 to 10.5 (2 to 40)	0.25 (1)	1/2" NPT	Frequency
MFS-31	2.5 to 52.8 (10 to 200)	1.3 (5)	1" NPT	Frequency
MFS-12	0.25 to 5.3 (1 to 20)	0.13 (0.5)	1/2" NPT	Frequency & analog

MODEL CHART			
Model	Range GPM (LPM)	Process Connection	Output
MFS2-1	0.07 to 1.3 (0.25 to 5)	1/2" male NPT	Frequency
MFS2-2	0.26 to 5.3 (1.0 to 20)	1/2" male NPT	Frequency
MFS2-3	0.66 to 13.2 (2.5 to 50)	3/4" male NPT	Frequency
MFS2-4	1.3 to 26.4 (5.0 to 100)	1" male NPT	Frequency
MFS2-5	2.6 to 52.8 (10 to 200)	1" male NPT	Frequency
MFS2-6	3.3 to 66.0 (12.5 to 250)	1-1/4" male NPT	Frequency

ACCESSORIES	
Model	Description
MFS-C3	4 pin cable socket M12x1 connect, 9.8 ft (3 m)
MFS-C5	4 pin cable socket M12x1 connect, 16.4 ft (5 m)
MFS-C10	4 pin cable socket M12x1 connect, 32.8 ft (10 m)



MFS-X 4 pin cable



# INSERTION THERMAL ENERGY METER

Field Adjustable, BACnet/Modbus® Outputs

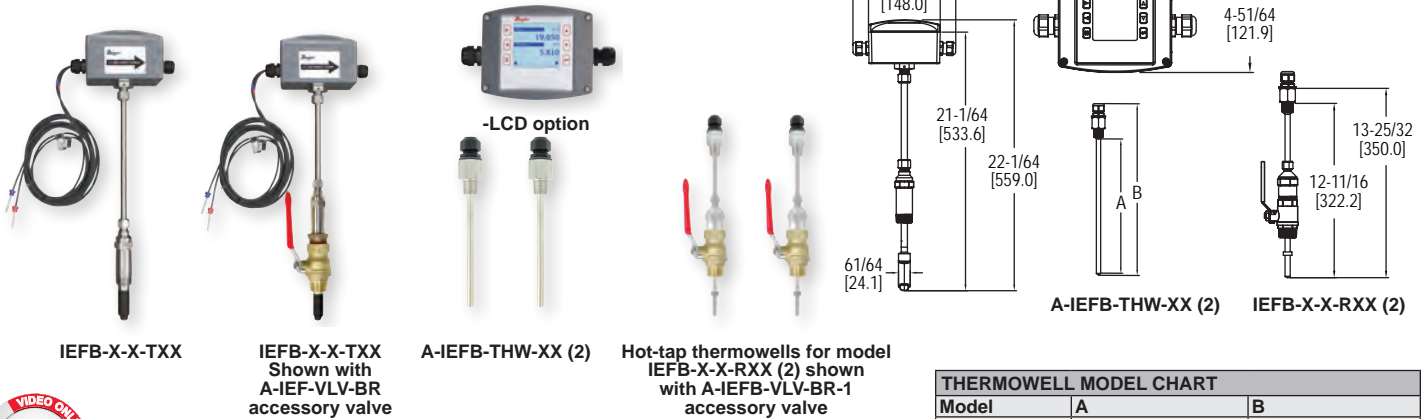

The **Series IEFB** is a field-adjustable insertion thermal energy meter that uses electromagnetic technology to accurately and reliably measure fluid velocity and energy consumption. The high accuracy IEFB is adjustable to fit pipe sizes from 4 to 10" (100 to 250 mm), while the standard accuracy IEFB fits pipe sizes 4 to 36" (100 to 900 mm). The energy meter is simple to install and incorporates a temperature meter and calculator into a single unit. The IEFB incorporates a temperature meter and a calculator into a single unit. The LCD display provides clear readings of the meter's values, including temperature and energy consumption, making it ideal for installation on chillers, boilers, and other heating and cooling applications. The high measuring accuracy and long lifetime keeps annual operating costs at a minimum. In addition, it offers several output options, including selectable BACnet MS/TP or Modbus® RTU communications protocol over 2-wire RS-485 and standard analog, frequency, and alarm outputs.

**FEATURES/BENEFITS**

- Flexible, field configurable setup displays (-LCD integral option or remote accessory A-IEF-DSP) accommodate a variety of application configurations. Application information is display selectable and includes pipe size, pipe material, liquid type, analog output, pulse/frequency output, alarm outputs, communication, outputs, damping, and calibration factor
- High performance accuracy is maintained through changes in temperature, density and/or viscosity
- The Setup Wizard and installation tool are simple to use, providing quick and precise installation
- Accessory setup kit A-IEF-KIT comes with a thickness gage and measuring tape to ensure exact installation depth
- The meter has no moving parts and electrodes that discourage fouling, which gives the meter a long lifecycle and minimizes the need for maintenance
- Hot-tap isolation valve accessories allow for easy installation and removal in operational systems without system downtime

**APPLICATIONS**

- Monitoring chiller cooling output performance
- Industrial boiler heating performance
- Energy efficiency monitoring
- Optimization of heat energy performance
- Commercial and residential heat energy consumption and metering
- District heating and cooling monitoring
- Energy cost allocation monitoring

**SPECIFICATIONS**

**Service:** Compatible clean or dirty non coating, conductive liquids.  
**Range:** 0 to 20 ft/s (0 to 6 m/s).\*  
**Wetted Materials:** Body shaft/fitting: 316 SS; Electrodes: 316 SS; Electrode cap: Polymer/polystyrene; O-ring: Silicone; Thermowells: 304 SS.  
**BTU Accuracy per EN1434/ASTM E3137/CSA C900.1-13:** High Accuracy Units: Class 2 for 2 to 20 ft/s (0.6 to 6 m/s)\*\*; Standard Accuracy Units: Class 3 for 6.5 to 20 ft/s (2 to 6 m/s)\*\*.  
**Flow Sensor Accuracy:** High Accuracy Units: ±0.5% of reading at calibrated velocity, ±1% of reading from 2 to 20 ft/s (0.6 to 6 m/s) ±0.02 ft/s (±0.006 m/s) at < 2 ft/s (0.6 m/s); Standard Accuracy Units: ±1% FS.  
**Temperature Accuracy:** Class B ±(0.30 + 0.005\*t)°C per EN60751.  
**Differential Temperature Accuracy:** Et = ±(0.5 + 3\*ΔΘmin/ΔΘ) % per EN1434.  
**Calculator Accuracy:** Ec = ±(0.5 + ΔΘmin/ΔΘ) % per EN1434.  
**Temperature Compensation:** 140 to 220°F (60 to 104.4°C) < 2% error over ±30°F (-1.1 °C) change, 40 to 70°F (4.4 to 21.1°C) < 2% error over ±10°F (-12.2°C) change.  
**Temperature Limits:** Ambient: -20 to 160°F (-29 to 71°C)\*\*; LCD -4 to 158°F (-20 to 70°C); Process: 15 to 250°F (-9 to 121°C); Storage: -40 to 185°F (-40 to 85°C).  
**Process Connection:** Flowmeter: 1" NPT or BSPT with accessory full port ball valve options; Thermowell: (2) 1/2" NPT or BSPT thermowell with 1" full port ball valve options.  
**Pressure Limit:** 400 psi (27.6 bar) @ 100°F (37.8°C).  
**Pressure Drop:** < 0.1 psi at 12 ft/s in 4" (<0.01 bar at 3.7 m/s in 100 mm) and larger pipe.  
**Outputs:** (1) Analog: 4-20 mA, 0-5 V, 0-10 V or 2-10 V (display selectable); (1) Pulse/Frequency: 0-15 V peak pulse, 0 to 500 Hz or scalable pulse output (display selectable); (2) Alarm: Empty pipe detection or minimum/maximum velocity, (display selectable) & Reverse flow output indication.  
**Power Requirements:** 12-42 VDC, .25 A @ 24 VDC; 12-36 VAC.  
**Electrical Connection:** Removable terminal blocks, (2) model selectable 1/2" female NPT conduit connection, (2) PG 16 gland or (2) PG 16 gland with 10 ft (3 m) 9 conductor 22 AWG plenum rated cables, accessory cable lengths up to 200 ft (61 m) optional.  
**Display (-LCD option):** 2 x 2" (50 x 50 mm) graphic LCD with backlight.  
**Conductivity:** >20 microsiemens.  
**Enclosure Material:** Powder coated die cast aluminum.  
**Enclosure Ratings:** NEMA 6P (IP68) (Non display models); NEMA 4X (IP66) (-LCD option).  
**Agency Approvals:** BTL.

**COMMUNICATIONS (-COM OPTION)**

**Type:** BACnet MS/TP or Modbus® RTU communication protocol (default disabled, display selectable).  
**Supported Baud Rates:** 9600, 19200, 38400, 57600, 76800, or 115200 bps (display selectable).  
**Device Load:** 1/8 unit load.

**ADDITIONAL SPECIFICATIONS**

**Applicable Pipe Material:** Most popular plastic and metal pipes; i.e. Carbon steel, SS, copper, UPVC/PVDF, galvanized steel, mild steel, and brass.  
**Applicable Pipe Size:** 4 to 36" (100 to 900 mm), model dependent. See model chart.  
**Diameter Length Requirements:** >10 upstream, >5 downstream.  
**Temperature Resistance:** Matched 4 wire platinum RTD's.  
**Relative Humidity:** 10 to 90% non-condensing.  
**Output Impedance:** 4 to 20 mA: 536 Ω; 5V: 500 Ω; 10V: 1.27k Ω.

\*For max flowrates >10 ft/s (3 m/s) order option -CC.  
 \*\*Verified at standard temperature 73.4°F (23°C) refer to listed standards for detailed accuracy formulations.



# INSERTION THERMAL ENERGY METER

Field Adjustable, BACnet/Modbus® Outputs

MODEL CHART							
Example	IEFB	-L	N	-CND	-R10	-LCD	IEFB-LN-CND-R10-LCD
Series	IEFB						Insertion thermal energy meter
Accuracy		L G S F I E T H					Standard accuracy <10" (250 mm) pipe; 1% FS Standard accuracy >10" (250 mm) pipe; 1% FS Standard accuracy 4 to 36" (100 to 900 mm) pipe; 1% FS High accuracy 4" (100 mm) pipe; 1% of reading High accuracy 6" (150 mm) pipe; 1% of reading High accuracy 8" (200 mm) pipe; 1% of reading High accuracy 10" (250 mm) pipe; 1% of reading High accuracy 4 to 10" (100 to 250 mm) pipe; 1% of reading
Process Connection			N B				1" Male NPT 1" Male BSPT
Housing Electrical Connection				CND PG 10			1/2" female NPT PG 16 gland without cable PG 16 gland with (2) 10' (3 m) cables
Temperature Sensors					T10 T20 T50 R10 R20 R50		(2) 10' (3 m) PT temperature sensors* (2) 20' (6 m) PT temperature sensors* (2) 50' (15 m) PT temperature sensors* (2) 10' (3 m) PT temperature sensors with hot-tap thermowells (2) 20' (6 m) PT temperature sensors with hot-tap thermowells (2) 50' (15 m) PT temperature sensors with hot-tap thermowells
Options						LCD COM NIST FC CC	Integral LCD display BACnet or Modbus® communications protocol (display selectable) NIST traceable calibration certification for flow and temperature Factory calibration certification for 0.5% of reading at single point Custom configuration (required input)

\*Thermowells not included. Refer to accessories model chart to purchase permanent thermowells.

ACCESSORIES	
Model	Description
A-IEF-KIT	Setup kit (includes setup display, thickness gage, and measuring tape) and universal power adapter
A-IEF-DSP	Setup display
A-IEF-VLV-BR†	1-1/4" full port isolation valve brass**
A-IEF-VLV-SS†	1-1/4" full port isolation valve 316 SS
Thermowells	
A-IEFB-THW-4	(2) 1/2" NPT, 4" thermowell for 4 to 7" pipe
A-IEFB-THW-6	(2) 1/2" NPT, 6" thermowell for ≥ 8" pipe
A-IEFB-THW-4-BSPT	(2) 1/2" BSPT, 4" thermowell for 4 to 7" pipe
A-IEFB-THW-6-BSPT	(2) 1/2" BSPT, 6" thermowell for ≥ 8" pipe
Hot-Tap Valves	
A-IEFB-VLV-BR-1†	(2) 1" NPT full port isolation valve brass for temperature sensor with 1" branch outlet and 1" nipple**
A-IEFB-VLV-SS-1†	(2) 1" NPT full port isolation valve 316 SS for temperature sensor with 1" branch outlet and 1" nipple

\*\*Brass fittings and pipe are not to be used with NSF Certified models. Brass valves are non-RoHS compliant.  
†BSPT valves also available

Modbus® is a registered trademark of Schneider Automation, Inc.

## SERIES A-IEF

# REMOTE DISPLAY FOR SERIES IEF AND IEFB

Convenient Access to IEF & IEFB Meter Readings

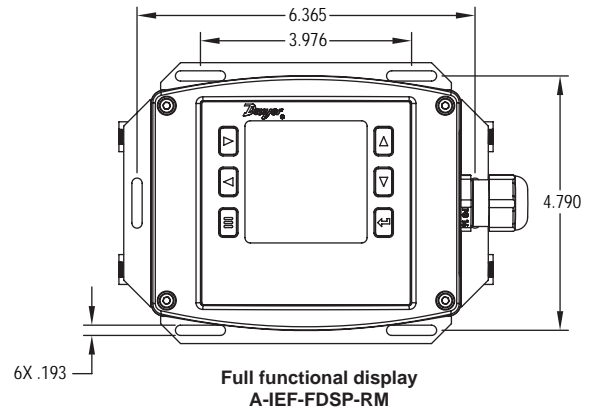
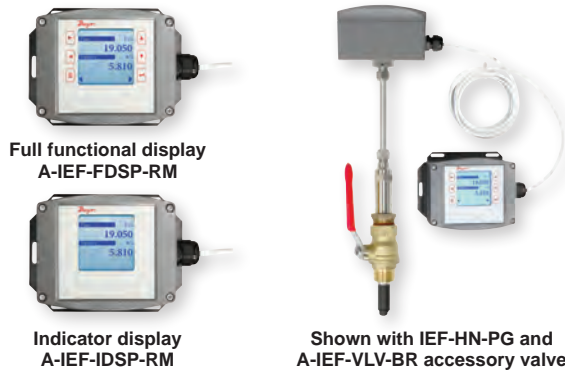

The **Series A-IEF Remote Display** can be installed almost anywhere near a Series IEF flow transmitter or IEFB thermal energy meter. Both the indicator display (A-IEF-IDSP-RM) and the full functional display (A-IEF-FDSP-RM) have a maximum display cable length of 100 ft (30 m) to permit easy viewing of flow readings. The full functional display allows for convenient adjustment of configuration settings and allows the user to save the IEF or IEFB configuration settings to a computer for printing.

### FEATURES/BENEFITS

- Full functional display can be used to set up the IEF/IEFB and adjust the settings if it is installed in a hard-to-reach location.
- Indicator display makes it convenient to read process values if the meter is inaccessible.
- Varying cable lengths of up to 100 ft (30 m) allows for flexible installation on a wall or pipe mount.
- Easy to install and wire in the field.

### APPLICATIONS

- Mechanical rooms with a small footprint
- Hard-to-reach piping
- Boilers and chillers
- Chilled water
- Condenser water
- Make-up water
- Heating water
- Boiler feed water
- Steam condensate

SPECIFICATIONS	
<b>Temperature Limits:</b>	Ambient: -4 to 158°F (-20 to 70°C); Storage: -40 to 185°F (-40 to 85°C).
<b>Display:</b>	3.3" diagonal graphic LCD. Backlight (full functional display only).
<b>Enclosure Material Housing:</b>	Powder coated die cast aluminum.
<b>Enclosure Rating:</b>	NEMA 4X (IP66).
<b>Electrical Connection:</b>	Removable terminal blocks, #22 AWG (100 ft (30 m) max).
<b>Mounting:</b>	Wall or pipe mount.
<b>Mounting Orientation:</b>	Any orientation.
<b>Weight:</b>	2.46 lbs (1.12kg).

MODEL CHART	
Model	Description
A-IEF-IDSP-RM	A-IEF-DSP-RM indicator remote display
A-IEF-FDSP-RM	A-IEF-DSP-RM full functional remote display

ACCESSORIES	
Model	Description
A-IEF-CBL-50	Plenum rated cable 50 ft (15.2 m)

Modbus® is a registered trademark of Schneider Automation, Inc.

# INSERTION ELECTROMAGNETIC FLOW TRANSMITTER

Field Configurable, High Accuracy, BACnet or Modbus® Protocol

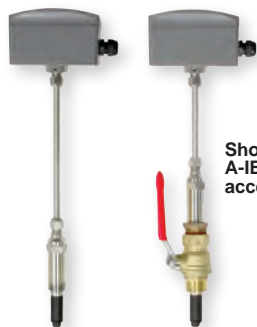

Shown with A-IEF-VLV-BR\*\* accessory valve

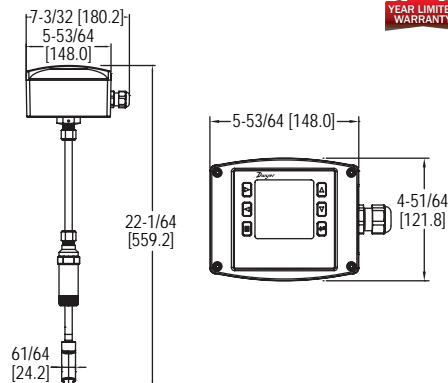

The Series IEF Insertion Electromagnetic Flow Transmitter is an adjustable insertion flowmeter featuring electromagnetic technology that accurately and reliably measures fluid velocity in addition to providing several continuous signal outputs. This series is specifically designed to offer superior performance paired with simple installation and use. One unit is adjustable to fit pipe sizes from 4 to 36" (102 to 914 mm), and offers several output options including selectable BACnet MS/TP or Modbus® RTU communications protocol over 2-wire RS-485 in addition to the standard analog, frequency and alarm outputs.

**FEATURES/BENEFITS**

- Field configurable setup displays (-LCD integral option or remote accessory A-IEF-DSP) allow for ultimate flexibility by accommodating a variety of application configurations with one model through multiple display configurations i.e. pipe size, pipe material, liquid type, analog output, pulse/frequency output, alarm outputs, communication outputs, damping, and calibration factor.
- High performance accuracy is maintained through changes in temperature, density or viscosity.
- Setup Wizard and installation tool are simple to use allowing for quick and precise installation.
- Accessory setup kit A-IEF-KIT ensures exact installation application depth with included thickness gage and measuring tape.
- Long Life Cycle and minimal maintenance requirements with no moving parts to wear or break and electrodes that discourage fouling.
- Isolation valve accessory options allow for installation in operational systems via hot-tap kit or easy removal without system downtime.
- NIST traceable pass/fail verification certificate included standard for Carbon Steel Schedule 40 pipes sized 4" (102 mm), 6" (150 mm), 8" (200 mm), and 10" (250 mm) with high accuracy option; 10" (250 mm) with standard option.

**APPLICATIONS**

- Boiler feed water
- Chilled water
- Open and closed loop condenser water
- Irrigation system
- Municipal water distribution
- Process and coolant flow
- Ground water remediation
- Chemical processing
- Pump protection
- Wastewater
- Mining

**SPECIFICATIONS**

**Service:** Compatible clean or dirty non coating, conductive liquids.  
**Range:** 0 to 20 ft/s (0 to 6 m/s).\*  
**Wetted Materials:** Body shaft/fitting: 316 SS; Electrodes: 316 SS; Electrode cap: Polymer/Polystyrene; O-ring: Silicon.  
**Accuracy:** High accuracy units: ±0.5% of reading at calibrated velocity; ±1% of reading from 2 to 20 ft/s (0.6 to 6 m/s); ±0.02 ft/s (±0.006 m/s) at < 2 ft/s (0.6 m/s); Standard accuracy units: ±1% FS.  
**Temperature Limits:** Ambient: -20 to 160°F (-29 to 71°C); Process: 15 to 250°F (-9 to 121°C); Storage: -40 to 185°F (-40 to 85°C).  
**Process Connection:** 1" NPT or BSPT with accessory full port ball valve options.  
**Pressure Limits:** 400 psi (27.6 bar) @ 100° F (37.8°C).  
**Pressure Drop:** < 0.1 psi at 12 ft/s in 4" (101.6 mm) and larger pipe.  
**Outputs:** (1) Analog: 4-20 mA, 0-5 V, 0-10 V or 2-10 V (display selectable); (1) Pulse/Frequency: 0 to 15 V peak pulse, 0 to 500 Hz or scalable pulse output (display selectable); (2) Alarm: (1) Empty pipe detection or minimum/maximum velocity, (display selectable); (1) Reverse flow output indication.  
**Power Requirements:** 12-42.4 VDC, .25 A @ 24 VDC; 12-36 VAC.  
**Electrical Connection:** Removable terminal blocks, model selectable 1/2" female NPT conduit connection, PG 16 gland or PG 16 gland with (2) 10 ft (3 m) 9 conductor 22 AWG plenum rated cables, accessory cable lengths up to 200 ft (61 m) optional.  
**Display (-LCD option):** 2" (5.08 cm) x 2" (5.08 cm) graphic LCD with backlight.  
**Conductivity:** >20 microsiemens.  
**Enclosure Material:** Powder coated die cast aluminum.  
**Enclosure Ratings:** NEMA 6P (IP68) (Non display models); NEMA 4X (IP66) (-LCD option).  
**Agency Approvals:** BTL, CE, NSF/ANSI 61 and 372.  
**COMMUNICATIONS (-COM OPTION)**  
**Type:** BACnet MS/TP or Modbus® RTU communication protocol (default disabled, display selectable).  
**Supported Baud Rates:** 9600, 19200, 38400, 57600, 76800, or 115200 bps (display selectable).  
**Device Load:** 1/8 unit load.  
**ADDITIONAL SPECIFICATIONS**  
**Applicable Pipe Material:** Most popular plastic and metal pipes; i.e. Carbon steel, SS, copper, UPVC/PVDF, galvanized steel, mild steel, and brass.  
**Applicable Pipe Size:** 4-36" (101 to 914 mm), model dependent. See model chart.  
**Diameter Length Requirements:** >10 upstream; >5 downstream.  
**Glycol:** 0 to 100% display selectable.

\*For max flowrates >10 ft/s (3 m/s) order option -CC.  
 \*\*Brass fittings and pipe are not to be used with NSF Certified models.

**MODEL CHART**

Example	IEF	-H	N	-CND	-LCD	IEF-HN-CND-LCD
<b>Series</b>	IEF					Insertion electromagnetic flow transmitter
<b>Accuracy</b>		L G S T I E T H				Standard accuracy <10" (250 mm) pipe; 1% FS Standard accuracy >10" (250 mm) pipe; 1% FS Standard accuracy 4 to 36" (100 to 900 mm) pipe; 1% FS High accuracy 4" (100 mm) pipe; 1% of reading High accuracy 6" (150 mm) pipe; 1% of reading High accuracy 8" (200 mm) pipe; 1% of reading High accuracy 10" (250 mm) pipe; 1% of reading High accuracy 4 to 10" (100 to 250 mm) pipe; 1% of reading
<b>Process Connection</b>			N B			1" male NPT 1" male BSPT
<b>Housing Electrical Connection</b>				CND PG 10		1/2" female NPT conduit connection without cable PG gland without cable PG gland with 10' (3 m) cable
<b>Options</b>					LCD COM NIST FC CC NW	Integral LCD display BACnet or Modbus® communication protocol (display selectable) Six point NIST traceable calibration certificate Factory calibration certificate for 0.5% of reading at single point Custom configured for specific installation NSF certified

Note: For CC option, must provide completed configuration paperwork.

**ACCESSORIES**

Model	Description
A-IEF-KIT	Setup kit (includes setup display, thickness gage and measuring tape), and universal power adapter
A-IEF-DSP	Setup display
A-IEF-CBL-50	Plenum rated cable 50 ft (15.2 m)
A-IEF-VLV-BR	1-1/4" full port isolation valve brass**
A-IEF-VLV-SS	1-1/4" full port isolation valve 316 SS
A-IEF-PA	AC wall adapter

\*\*Brass fittings and pipe are not to be used with NSF Certified models. Brass valves are non-RoHS compliant.

Modbus® is a registered trademark of Schneider Automation, Inc.

A-IEF Remote Display now available: See page 294

# ULTRASONIC ENERGY METERS

Flow & Temperature Monitoring Capability, Modbus® or BACnet Communication



TUF-150/400

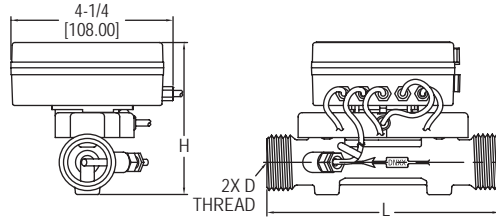

TUF-500

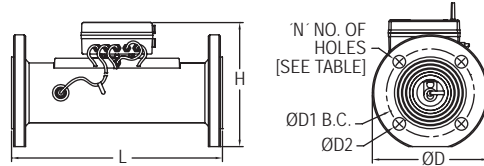

DIMENSIONS in [mm]			
Model	L	D	H
TUF-150-XX	4-21/64 [110.00]	G3/4B	3-31/32 [101.00]
TUF-200-XX	5-1/8 [130.00]	G1B	3-31/32 [101.00]
TUF-250-XX	6-19/64 [160.00]	G11/4B	4-11/64 [106.00]
TUF-320-XX	7-3/32 [180.00]	G11/2B	4-29/64 [113.00]
TUF-400-XX	7-7/8 [200.00]	G2B	4-49/64 [121.00]

DIMENSIONS in [mm]						
Model	L	ØD	H	ØD1	ØD2	N
TUF-500-XX	7-7/8 [200]	6-1/2 [165.00]	9-27/32 [250]	4-59/64 [125.00]	45/64 [18.00]	4
TUF-650-XX	7-7/8 [200]	7-9/32 [185.00]	10-7/16 [265]	5-45/64 [145.00]	45/64 [18.00]	4
TUF-800-XX	8-55/64 [225]	7-7/8 [200.00]	11-1/32 [280]	6-19/64 [160.00]	45/64 [18.00]	8
TUF-1000-XX	9-27/32 [250]	8-21/32 [220.00]	12-13/64 [310]	7-3/32 [180.00]	45/64 [18.00]	8
TUF-1250-XX	9-27/32 [250]	9-27/32 [250.00]	12-63/64 [330]	8-17/64 [180.00]	45/64 [18.00]	8

The Series TUF Ultrasonic Energy Meters are highly accurate and stable energy meter that utilizes ultrasonic technology to measure heating and cooling energy consumption. The Series TUF is a compact meter with a flowmeter and energy calculator in one, making it great for installation on chillers and boilers.

**FEATURES/BENEFITS**

- Lower maintenance costs with local parameter display and no moving parts
- Serial communication output allows for easy transfer of data
- Flow and temperature monitor in one unit eliminates the need for multiple units

**APPLICATIONS**

- Heat metering
- Tenant billing
- Utilities billing
- Monitoring of water heating or cooling: radiators, fan coils

**INSTRUCTIONS FOR ORDERING**

- Choose 1 ultrasonic energy meter model (includes 2 BSPP pipe fittings, 2 tightening nuts, 2 O-rings, and 1 thermowell with welding collar)
- Choose 1 pipe fitting model given the appropriate fitting size if NPT or BSPT connections are required (for DN15 to DN40 only)\*

**Example:** TUF-150-MD, Fitting Size: A, select pipe fitting Model WM-ACC-C01 or WM-ACC-C11.

**SPECIFICATIONS**

**Service:** Clean, compatible liquids.  
**Wetted Materials:** Brass and 316L SS.  
**Range:** See chart.  
**Display:** 8-digit LED.  
**Accuracy:** BTU: EN1434/CJ128 Class 2; Flow:  $\pm(2+(0.02 Q_p / Q))\%$ ; Temperature:  $\pm 0.1^\circ\text{C}$ .  
**Power Requirements:** 24 VDC/VAC (model dependent) or 3.6 V ER26500 lithium metal battery, user supplied and installed, battery acts as back-up if power is lost.  
**Power Consumption:** 1 W.  
**Temperature Limits:** Ambient: 41 to 131°F (5 to 55°C); Process: 36 to 203°F (2 to 95°C).  
**Humidity Limit:** < 93%.  
**Pressure Limits:** 232 psi (16 bar) for DN15 to DN40; 362 psi (25 bar) for >DN50.  
**Pressure Drop:** < 1.5 psi (10 kPa).  
**Process Connection:** See chart.  
**Serial Communications:** Modbus® RTU or BACnet MSTP (selectable)\*\*.  
**Enclosure Rating:** IP65.  
**Enclosure Material:** Plastic.  
**Repeatability:** Flowmeter: 1%.  
**Electrical Connections:** 3' (0.91 m) 4x0.2 mm2 cable with terminal block.  
**Flow Direction:** Unidirectional.  
**Mounting Orientation:** Horizontal or vertical.  
**Weight:** See chart.  
**Agency Approvals:** CE.

\*\*M-BUS available upon request.

MODEL CHART										
Ultrasonic Energy Meter Model	Body Size†	Pipe Size		Fitting Size	Communication	Meter Connection	GPM (LPM)			Weight lb (kg)
		in	mm				Min Flow (Qi)	Nominal Flow Range (Qp)	Max Flow (Qs)	
TUF-150-MD	DN15	1/2	15	A	Modbus®	G-3/4	0.1 (0.5)	6.6 (25)	13 (50)	3.1 (1.4)
TUF-200-MD	DN20	3/4	20	B	Modbus®	G1	0.2 (0.8)	11 (42)	22 (83)	3.1 (1.4)
TUF-250-MD	DN25	1	25	C	Modbus®	G1-1/4	0.3 (1.2)	15 (58)	31 (117)	4.1 (1.8)
TUF-320-MD	DN32	1-1/4	32	D	Modbus®	G1-1/2	0.5 (2)	26 (100)	53 (200)	5.2 (2.3)
TUF-400-MD	DN40	1-1/2	40	E	Modbus®	G2	0.9 (3)	44 (167)	88 (333)	6.6 (3)
TUF-500-MD*	DN50	2	50	-	Modbus®	Flange	1.3 (5)	66 (250)	132 (500)	33 (15)
TUF-650-MD	DN65	2-1/2	65	-	Modbus®	Flange	2.2 (8.3)	110 (417)	220 (833)	10.1 (4.6)
TUF-800-MD	DN80	3	80	-	Modbus®	Flange	3.5 (13.3)	176 (667)	352 (1333)	13.5 (6.1)
TUF-1000-MD	DN100	4	100	-	Modbus®	Flange	5.3 (20)	264 (1000)	528 (2000)	16.5 (7.5)
TUF-1250-MD	DN125	5	125	-	Modbus®	Flange	8.8 (33)	440 (1667)	881 (3333)	21.1 (9.6)
TUF-150-BN	DN15	1/2	15	A	BACnet	G-3/4	0.1 (0.5)	6.6 (25)	13 (50)	3.1 (1.4)
TUF-200-BN	DN20	3/4	20	B	BACnet	G2	0.2 (0.8)	11 (42)	22 (83)	3.1 (1.4)
TUF-250-BN	DN25	1	25	C	BACnet	G1-1/4	0.3 (1.2)	15 (58)	31 (117)	4.1 (1.8)
TUF-320-BN	DN32	1-1/4	32	D	BACnet	G1-1/2	0.5 (2)	26 (100)	53 (200)	5.2 (2.3)
TUF-400-BN	DN40	1-1/2	40	E	BACnet	G2	0.9 (3)	44 (167)	88 (333)	6.6 (3)
TUF-500-BN*	DN50	2	50	-	BACnet	Flange	1.3 (5)	66 (250)	132 (500)	33 (15)
TUF-650-BN	DN65	2-1/2	65	-	BACnet	Flange	2.2 (8.3)	110 (417)	220 (833)	10.1 (4.6)
TUF-800-BN	DN80	3	80	-	BACnet	Flange	3.5 (13.3)	176 (667)	352 (1333)	13.5 (6.1)
TUF-1000-BN	DN100	4	100	-	BACnet	Flange	5.3 (20)	264 (1000)	528 (2000)	16.5 (7.5)
TUF-1250-BN	DN125	5	125	-	BACnet	Flange	8.8 (33)	440 (1667)	881 (3333)	21.1 (9.6)
<b>Model</b>	<b>Power Requirements</b>									
TUF-XXX-XX	24 VAC/VDC									
TUF-XXX-XX-DC	24 VDC									

\*A pipe fitting is required to use the DN15 to DN40 energy meters. The DN50 has a flange connection and does not require a pipe fitting.  
 †For additional sizes up to 8" (203.2 mm) contact factory.

MODEL CHART							
Fitting Size	Pipe Fitting Model*	Process Connection Size	Weight lb (kg)	Fitting Size	Pipe Fitting Model*	Process Connection Size	Weight lb (kg)
A	WM-ACC-C01	1/2" NPT	0.6 (0.3)	C	WM-ACC-C13	1" BSPT	1.8 (0.8)
A	WM-ACC-C11	1/2" BSPT	0.6 (0.3)	D	WM-ACC-C04	1-1/4" NPT	2.3 (1.1)
B	WM-ACC-C02	3/4" NPT	1.2 (0.5)	D	WM-ACC-C14	1-1/4" BSPT	2.3 (1.1)
B	WM-ACC-C12	3/4" BSPT	1.2 (0.5)	E	WM-ACC-C05	1-1/2" NPT	4.4 (2)
C	WM-ACC-C03	1" NPT	1.8 (0.8)	E	WM-ACC-C15	1-1/2" BSPT	4.4 (2)

\*Each model includes 1 fitting.

USA: California Proposition 65  
 ⚠ WARNING: Cancer and Reproductive Harm  
[www.P65Warnings.ca.gov](http://www.P65Warnings.ca.gov)

Modbus® is a registered trademark of Schneider Automation, Inc.



# GAS MASS FLOW METERS

Flow Range Up to 1000 L/min, Pressures Up to 1000 psi, NIST Traceable

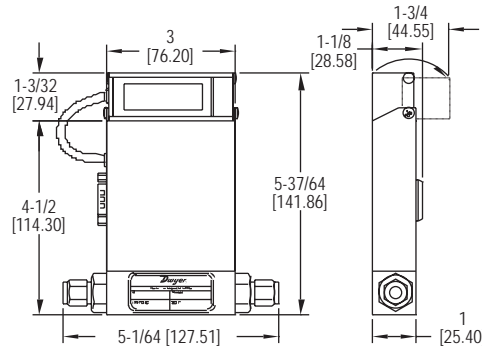

**Model GFM-1101 thru GFM-1111  
& GFM-2101 thru GFM-2111**

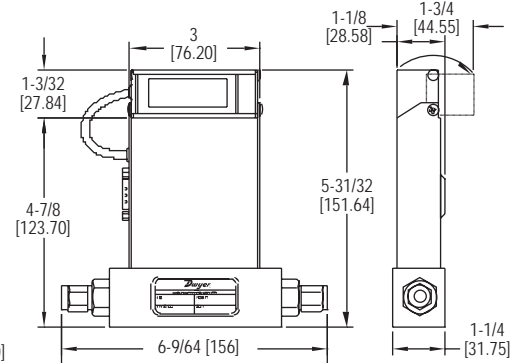

**Model GFM-1140  
thru GFM-1142 & GFM-2140  
thru GFM-2142**  
**Model GFM-1130  
thru GFM-1133 & GFM-2130  
thru GFM-2133**

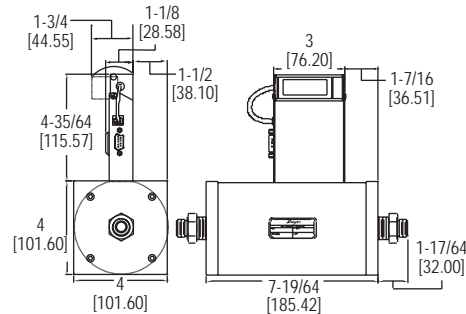

**Model GFM-1143 thru GFM-1145  
& GFM-2143 thru GFM-2145**

Series GFM Gas Mass Flow Meters combine a straight tube sensor with a restrictor flow element to provide high accuracy and repeatability. Flow rates are virtually unaffected by temperature and pressure variations. Actual gas flow is displayed in engineering units on a 3-digit, 90° tiltable LCD readout. Units can be used with Series GFT Flow Totalizer for applications requiring totalization. Series GFM includes a NIST traceable certificate.

**SPECIFICATIONS**

**Service:** Clean gases compatible with wetted parts.  
**Wetted Materials:** GFM-1XXX: Anodized aluminum, brass, 316 SS and fluoroeastomer O-rings; GFM-2XXX: 316 SS and fluoroeastomer O-rings.  
**Accuracy:** ±1% FS including linearity over 59 to 77°F (5 to 25°C) and 5 to 60 psia (0.34 to 4 bar); Series X143, X144, X145, ±1.5% FS.  
**Repeatability:** ±0.25% of FS.  
**Response Time:** 2 s to within ±2% of actual flow.  
**Output:** Linear 0-5 VDC and 4-20 mA.  
**Max. Particulate Size:** 5 microns.  
**Temperature Limits:** 32 to 122°F (0 to 50°C).  
**Power Supply:** ±12 VDC.  
**Process Connections:** 1/4" compression fitting for flow rates ≤50 L/m; 3/8" for 100 and 200 L/m; 1/2" for 500 L/min; 3/4" for 1000 L/min.  
**Pressure Limits:** 1000 psig (68.9 bar); Series GFM-X143, X144, X145, 500 psig (34.5 bar).  
**Leak Integrity:** 1 x 10<sup>-9</sup> sccs of He.  
**Display:** 90° tiltable, 3-1/2 digit.  
**Agency Approvals:** CE.

ACCESSORIES	
Model	Description
GFM-110P	110 V power supply
GFM-220PE	220 V power supply
GFM-CBL4	3' cable for 4-20 mA output
GFM-CBL5	3' cable for 0-5 VDC output

MODEL CHART							
Model*	Material	Flow Range	Process Connector Compression Fitting	Model*	Material	Flow Range	Process Connector Compression Fitting
GFM-1101	Aluminum	0 to 10 mL/m	1/4"	GFM-2101	SS	0 to 10 mL/m	1/4"
GFM-1102	Aluminum	0 to 20 mL/m	1/4"	GFM-2102	SS	0 to 20 mL/m	1/4"
GFM-1103	Aluminum	0 to 50 mL/m	1/4"	GFM-2103	SS	0 to 50 mL/m	1/4"
GFM-1104	Aluminum	0 to 100 mL/m	1/4"	GFM-2104	SS	0 to 100 mL/m	1/4"
GFM-1105	Aluminum	0 to 200 mL/m	1/4"	GFM-2105	SS	0 to 200 mL/m	1/4"
GFM-1106	Aluminum	0 to 500 mL/m	1/4"	GFM-2106	SS	0 to 500 mL/m	1/4"
GFM-1107	Aluminum	0 to 1000 mL/m	1/4"	GFM-2107	SS	0 to 1000 mL/m	1/4"
GFM-1108	Aluminum	0 to 2 L/min	1/4"	GFM-2108	SS	0 to 2 L/min	1/4"
GFM-1109	Aluminum	0 to 5 L/min	1/4"	GFM-2109	SS	0 to 5 L/min	1/4"
GFM-1111	Aluminum	0 to 15 L/min	1/4"	GFM-2111	SS	0 to 15 L/min	1/4"
GFM-1131	Aluminum	0 to 30 L/min	1/4"	GFM-2131	SS	0 to 30 L/min	1/4"
GFM-1133	Aluminum	0 to 50 L/min	1/4"	GFM-2133	SS	0 to 50 L/min	1/4"
GFM-1142	Aluminum	0 to 100 L/min	3/8"	GFM-2142	SS	0 to 100 L/min	3/8"
GFM-1144	Aluminum	0 to 200 L/min	3/8"	GFM-2143	SS	0 to 200 L/min	3/8"
GFM-1144	Aluminum	0 to 500 L/min	1/2"	GFM-2144	SS	0 to 500 L/min	1/2"
GFM-1145	Aluminum	0 to 1000 L/min	3/4"	GFM-2145	SS	0 to 1000 L/min	3/4"

\*Specified flow ranges are for an equivalent flow of nitrogen at 70°F (21°C) @ 760 mm Hg.

Mass Flowmeters/  
Controllers



# GAS MASS FLOW METERS

Flow Monitoring, Push-Button Configuration



GFM3



GFM4

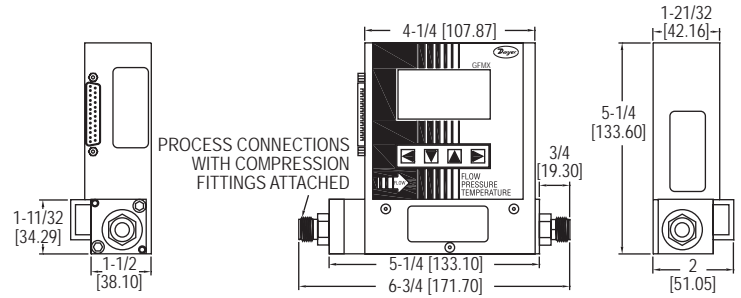

The Series GFM3 & GFM4 Gas Mass Flow Meters are an ideal choice for the measurement of flow rates of a wide variety of gases. Unit can be calibrated for a variety of gases via push-button with 0-5 VDC, 0-10 VDC or 4-20 mA and relay outputs.

**FEATURES/BENEFITS**

- Multi parameter flow meter supports various functions such as flow totalizer, flow, temperature, and pressure alarms, and is available in a choice of 0-5 VDC, 0-10 VDC, or 4-20 mA output signals
- Set alarms remotely via digital interface for flow, pressure, and temperature to alert user of high or low thresholds being exceeded
- Programmable 12-digit totalizer for total gas volume indication, and is available in the choice of 0-5 VDC, 0-10 VDC, or 4-20 mA output signals
- Standard four button keypad and large 128 x 64 graphical LCD with backlight allows easy access to the many features
- Digital interface operates through available RS-485 or RS-232, providing access to internal data parameters and multi-drop capability of up to 255 units (RS-485 only)
- Set alarms remotely via digital interface for flow to alert user of high or low thresholds being exceeded
- Internal conversion factors for up to 32 gases
- NIST traceable certificate included
- Automatic zero adjustment
- Self-diagnostic tests

**SPECIFICATIONS**

- Service:** Clean gases compatible with wetted parts.
- Wetted Materials:** 316 SS, 416 SS; Fluoroelastomer, Buna-N, EPR or PTFE O-rings.
- Accuracy:** ±1% FS.
- Repeatability:** ±0.25% FS.
- Response Time:** 0.6 to 1.0 s to within ±2% of set point over 20 to 100% FS.
- Output Signal:** Linear 0-5 VDC (3000 Ω min. load impedance); 0-10 VDC (6000 Ω min. load impedance); 4-20 mA (500 Ω max. loop resistance).
- Relay Rating:** 1 A @ 24 VDC.
- Max. Particulate Size:** 5 microns.
- Temperature Limits:** Ambient: 32 to 122°F (0 to 50°C); Dry Gases: 14 to 122°F (-10 to 50°C).
- Power Supply:** 12 VDC; 15 VDC; ±24 VDC.
- Process Connections:** 1/8" compression fitting for flow rates ≤ 10 L/min; 1/4" for ≤ 50 L/min; 3/8" for ≤ 100 L/min.
- Pressure Limits:** 500 psia (35 bar).
- Leak Integrity:** 1 x 10<sup>-9</sup> smL/sec of helium.
- Display:** 128 x 64 graphic LCD with backlight.
- Weight:** 1 lb (.45 kg).

**APPLICATIONS**

- Gas flow measurement
- Gas flow control
- Operating pumps and valves
- Process equipment
- Vacuum processes
- Glass and metal coating
- Film deposition

**ACCESSORIES**

Model	Description
A-110N12	110 VAC power supply, 12 VDC standard interface
A-110N24	110 VAC power supply, 24 VDC standard interface
A-110NA15	110 VAC power supply, 15 VDC standard interface

MODEL CHART											
Example	GFM3	-AIR	-010	-5	-E	-B	-L	-B	-C	-2	GFM3-AIR-010-5-E-B-L-B-C-2
Series	GFM3 GFM4										Gas mass flow meter Gas mass flow meter with temperature
Specialty Gas & K-Factor		AIR AR C2H2 C3H8 C4H10 CH4 CO CO2 HF HE H2 N2 NH3 O2 SO2									Air 1.0000 Argon 1.4573 Acetylene 0.5829 Propane 0.3500 Butane 0.2631 Methane 0.7175 Carbon monoxide 1.0000 Carbon dioxide 0.7382 Hydrogen fluoride 0.9998 Helium 1.4540 Hydrogen 1.0106 Nitrogen 1.0000 Ammonia 0.7310 Oxygen 0.9926 Sulfur dioxide 0.6900
Body Size			010 050 100								Low flow Medium flow High flow
Power Supply				5 2 4							±15 VDC 12 VDC 24 VDC
Seal Material					V B E T						Fluoroelastomer Buna-N EPR PTFE
Fittings								A B D			1/4" compression (low) 1/8" compression (medium) 3/8" compression (high)
Display							L				LED display
Flow Output Signal								A B G			0-5 VDC 4-20 mA 0-10 VDC
Temperature & Pressure Output Signal									A B C D E F G H I J		N.A./N.A. 0-5 VDC/0-5 VDC 0-5 VDC/4-20 mA 0-5 VDC/0-10 VDC 4-20 mA/0-5 VDC 4-20 mA/4-20 mA 4-20 mA/0-10 VDC 0-10 VDC/0-5 VDC 0-10 VDC/4-20 mA 0-10 VDC/0-10 VDC
Digital Interface										2 5 9	RS232 RS485 PROFIBUS

Note: Specify flow range at time of order

# GAS MASS FLOW CONTROLLERS

Flow Range Up to 1000 L/min, Pressures Up to 500 psi, NIST Traceable

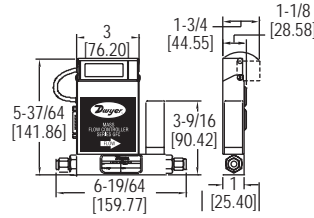

**Model GFC-1101 thru GFC-1111  
& GFC-2101 thru GFC-2111**

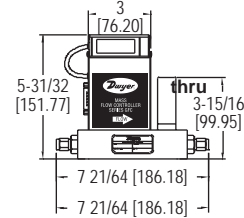

**Model GFC-1130 thru GFC-1133  
& GFC-2130 thru GFC-2133**

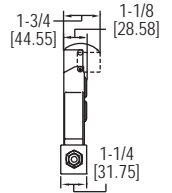

**Model GFC-1140 thru  
GFC-1142 & GFC-2140  
thru GFC-2142**

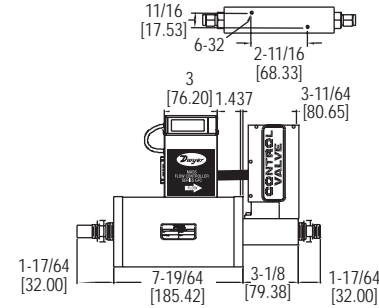
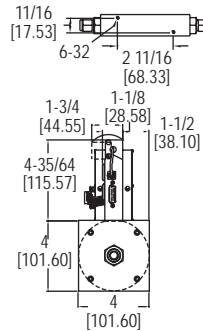
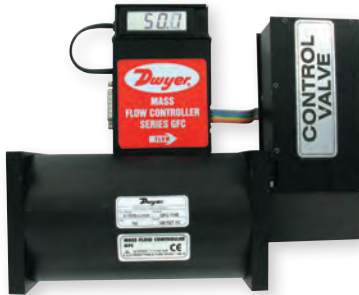

**Model GFC-1143 thru GFC-1145  
& GFC-2143 thru GFC-2145**

The **Series GFC Gas Mass Flow Controllers** combine a straight tube sensor with a restrictor flow element. It is available for flow ranges up to 1000 L/min and offered in aluminum or 316 SS in 1/4", 3/8", 1/2" and 3/4" sizes.

**FEATURES/BENEFITS**

- Provides high accuracy and repeatability
- Flow rates are virtually unaffected by temperature and pressure variations
- Utilizes an electromagnetic valve and PID electronics to maintain continuous control by comparing measured sensor signal set to flow rates
- Set points can be adjusted with local potentiometers or remotely via 0 to 5 VDC or 4 to 20 mA analog signal
- Actual gas flow is displayed in engineering units on a 3-1/2 digit, 90° tiltable LCD readout
- Can be used with Series GFT2 Flow Totalizer for applications requiring totalization
- NIST traceable certificate included

**APPLICATIONS**

- Gas flow measurement
- Gas flow control
- Operating pumps and valves
- Process equipment
- Vacuum processes
- Glass and metal coating
- Film deposition

**SPECIFICATIONS**

**Service:** Clean gases compatible with wetted parts.  
**Wetted Materials:** GFC-1XXX: Anodized aluminum, brass, 316 SS and fluoroelastomer O-rings; GFC-2XXX: 316 SS and fluoroelastomer O-rings.  
**Accuracy:** ±1% FS including linearity over 59 to 77°F (5 to 25°C) and 5 to 60 psia (0.34 to 4 bar); Series GFC X143, X144, X145, ±1.5% FS.  
**Repeatability:** ±0.25% FS.  
**Response Time:** 2 s to within ±2% of actual flow.  
**Output:** Linear 0-5 VDC and 4-20 mA.  
**Max. Particulate Size:** 5 microns.  
**Temperature Limits:** 32 to 122°F (0 to 50°C).  
**Power Supply:** ±12 VDC.  
**Process Connections:** 1/4" compression fitting for flow rates ≤50 L/m; 3/8" for 100 and 200 L/m; 1/2" for 500 L/min; 3/4" for 1000 L/min.  
**Pressure Limits:** 1000 psig (68.9 bar); Series GFC-X143, X144, X145, 500 psig (34.5 bar).  
**Leak Integrity:** 1 x 10<sup>-9</sup> sccs of He.  
**Display:** 90° tiltable, 3-1/2 digit.  
**Agency Approvals:** CE.

Mass Flowmeters/  
Controllers

MODEL CHART			
Aluminum Model	SS Model	Flow Range	Process Connector Compression Fitting
GFC-1101*	GFC-2101*	0 to 10 mL/m	1/4"
GFC-1102*	GFC-2102*	0 to 20 mL/m	1/4"
GFC-1103*	GFC-2103*	0 to 50 mL/m	1/4"
GFC-1104*	GFC-2104*	0 to 100 mL/m	1/4"
GFC-1105*	GFC-2105*	0 to 200 mL/m	1/4"
GFC-1106*	GFC-2106*	0 to 500 mL/m	1/4"
GFC-1107*	GFC-2107*	0 to 1000 mL/m	1/4"
GFC-1108*	GFC-2108*	0 to 2 L/min	1/4"
GFC-1109*	GFC-2109*	0 to 5 L/min	1/4"
GFC-1111*	GFC-2111*	0 to 15 L/min	1/4"
GFC-1131*	GFC-2131*	0 to 30 L/min	1/4"
GFC-1133*	GFC-2133*	0 to 50 L/min	1/4"
GFC-1142*	GFC-2142*	0 to 100 L/min	3/8"
GFC-1143*	GFC-2143*	0 to 200 L/min	3/8"
GFC-1144*	GFC-2144*	0 to 500 L/min	1/2"
GFC-1145*	GFC-2145*	0 to 1000 L/min	3/4"

\*Specified flow ranges are for an equivalent flow of nitrogen at 70°F (21°C) @ 760 mm Hg

ACCESSORIES	
Model	Description
GFC-110P	110 V power supply
GFC-220PE	220 V power supply
GFC-CBL1	8' cable with 15-pin connector
GFC-CBL3	3' extension cable for LCD readout

USA: California Proposition 65  
 ⚠WARNING: Cancer and Reproductive Harm - www.P65Warnings.ca.gov

**SELECTION GUIDE**  
pages 300-303

**TYPICAL APPLICATIONS**  
pages 304-305

  
**Level Indicators**  
pages 306-307

  
**Water Leak Detectors**  
page 308

  
**Level Switches, Float**  
pages 309-319

  
**Level Switches, Optical**  
page 320

  
**Level Switches, Displacer**  
page 320

  
**Level Switches, Capacitive**  
pages 321-322

  
**Level Switches, Vibrating Rod**  
page 322

  
**Level Switches, Tuning Fork**  
page 323

  
**Level Switches, Paddle**  
pages 324-325

  
**Level Switches, Diaphragm**  
pages 326-327

  
**Level Transmitters, Submersible**  
pages 329-331

  
**Level Transmitters, Capacitive**  
page 332

  
**Level Transmitters, Float**  
page 333

  
**Level Transmitters, Ultrasonic**  
pages 334-335

  
**Level/Pump Controllers**  
pages 336-338

  
**Bin Vibrators/ Aerators**  
pages 339-340

## FEATURED PRODUCTS

### CAPACITIVE LEVEL SWITCH SERIES CLS2 | page 321



- No moving parts to jam, wear or break
- Auto calibrates for easy set up



### SUBMERSIBLE LEVEL TRANSMITTER SERIES PBLTX | page 330



- Durable cage style design ensures long life in harsh application environments
- Large flush 36 SS diaphragm will not clog
- cULus intrinsically safe

# LIQUID

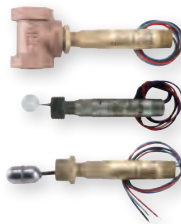
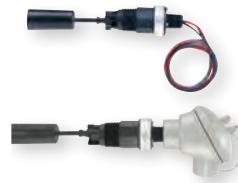
## Level Switches

				
<b>SERIES</b>	<b>L4</b> - page 309	<b>L6</b> - page 310	<b>L8</b> - page 311	<b>L10</b> - page 312
<b>Service</b>	Liquids	Liquids	Liquids	Liquids
<b>Wetted Materials</b>	316 SS	304 SS	316 SS	304 SS
<b>Temperature Limits</b>	275°F (135°C)	220°F (105°C)	212°F (100°C)	200°F (93°C)
<b>Pressure Limits</b>	2000 psig with option bar	2000 psi (138 bar)	150 PSIG (10.34 bar)	2000 (137.137.8 bar)
<b>Process Connection</b>	1-1/2" or 2-1/2" male NPT	1" male NPT or 1" female NPT with external float	1" male NPT	1" male NPT
<b>Min. Specific Gravity</b>	0.7	0.9	0.6	0.9
<b>Output</b>	SPDT or DPDT	SPDT or DPDT	SPDT	SPST
<b>Mounting Orientation</b>	Horizontal with optional vertical	Horizontal	Horizontal	Horizontal
<b>Agency Approvals</b>	ATEX, CE, CSA, FM, IECEx, UL	ATEX, CE, CSA, FM, IECEx, KTL, UL	CE, cURus	CSA, UR

# LIQUID

## Level Switches

					
<b>SERIES</b>	<b>F7-MS</b> - page 317	<b>123</b> - page 318	<b>102</b> - page 318	<b>CFS2</b> - page 319	<b>FSW2</b> - page 319
<b>Service</b>	Liquids	Liquids	Liquids	Liquids	Liquids
<b>Wetted Materials</b>	Brass or 316 SS	304 SS	Cast iron	Polypropylene	Polypropylene
<b>Temperature Limits</b>	Buna-N floats: 180°F (82.2°C) in oil, 230°F (110°C) in water; SS floats: 300°F (148.9°C)	365°F (185°C)	425°F (218°C)	122°F (50°C)	122°F (50°C)
<b>Pressure Limits</b>	750 psi (51.7 bar)	150 psig (10.34 bar)	400 psig (27.6 bar)	14.5 psi (1 bar)	29 psi (2 bar)
<b>Process Connection</b>	1/2", 1-1/4", 2", or 3" 150# flange	1" female NPT	1" female NPT	N/A	N/A
<b>Min. Specific Gravity</b>	0.55	0.88	0.6	0.6	0.6
<b>Output</b>	SPST or SPDT	SPDT, DPDT or (2) SPDT	SPDT, DPDT or (2) SPDT	SPST or SPDT	SPST or SPDT
<b>Mounting Orientation</b>	Vertical ±30°	Vertical	Vertical	Horizontal	Vertical
<b>Agency Approvals</b>	N/A	CSA, UL	UL	CE, UL/CSA	CE

These Selection Guides are for quick comparison of similar products. Please refer to the catalog page number referenced for complete product information and specifications.







# LIQUID Level Switches

				
<b>SERIES</b>	<b>F7-MLK</b> - page 312	<b>F6 &amp; F7</b> - page 313	<b>F6 &amp; F7</b> - page 314	<b>F7-MM</b> - page 316
<b>Service</b>	Liquids	Liquids	Liquids	Liquids
<b>Wetted Materials</b>	Buna-N/Brass	Polypropylene, 316 SS, or Buna-N*	Polypropylene, 316 SS, or Buna-N*	Brass or 316 SS
<b>Temperature Limits</b>	221°F (105°C)	176°F (80°C) or higher*	176°F (80°C) or higher*	180°F (82.2°C) or higher*
<b>Pressure Limits</b>	150 psig (10 bar)	50 psig (3 bar) or higher*	15 psig (1 bar) or higher*	1000 psi (68.95 bar)
<b>Process Connection</b>	2" male NPT	M16x2, 18" male NPT, 1/2" male NPT, 3/4" female NPT, or 3/8"-24" UNF-2A*	1/8" or 1/4" male NPT*	1/8", 3/4", or 1" male NPT, 3-5/8" flange, 1-5/16-12UNF-2A, 3/8"-24 thread, or 2" male NPT with 1/2" conduit
<b>Min. Specific Gravity</b>	0.45	0.45 or higher*	0.45 or higher*	0.45
<b>Output</b>	SPST	SPST	SPST	SPST
<b>Mounting Orientation</b>	Vertical	Horizontal	Vertical	Vertical
<b>Agency Approvals</b>	N/A	N/A	CE, UL*	N/A

\*Varies per product

# LIQUID Level Switches

				
<b>SERIES</b>	<b>OLS</b> - page 320	<b>B-190</b> - page 320	<b>CLS2</b> - page 321	<b>CLS1</b> - page 322
<b>Service</b>	Liquids	Liquids	Liquids, powder, bulk materials	Solids, liquids, slurries
<b>Wetted Materials</b>	316 SS, Polysulfone or PFA	316 SS	316 SS	CPVC
<b>Temperature Limits</b>	200°F (93.3°C)	200°F (93.3°C)	185°F (85°C)	240°F (116°C)
<b>Pressure Limits</b>	1000 psig (69 bar)	125 psig (8.6 bar)	365 psi (25 bar)	30 psig (2.06 bar)
<b>Process Connection</b>	1/2" male NPT	4" 125 # cast iron flange	3/4", 1", or 1-1/2" male NPT or BSPT or 1-1/2" or 2" sanitary clamp	1" male NPS
<b>Min. Specific Gravity</b>	N/A	0.5	N/A	N/A
<b>Output</b>	NPN open collector	SPST or SPDT	DPDT	SPDT
<b>Mounting Orientation</b>	Any position	Vertical	Vertical or horizontal	Vertical or horizontal
<b>Agency Approvals</b>	N/A	UL	CE, cULus	N/A

These Selection Guides are for quick comparison of similar products. Please refer to the catalog page number referenced for complete product information and specifications.





# BULK

## Level Switches

					
<b>SERIES</b>	<b>CLS2</b> - page 321	<b>CLS1</b> - page 322	<b>VRLS</b> - page 322	<b>TFLS</b> - page 323	<b>CTF</b> - page 323
<b>Service</b>	Liquids, powder and bulk	Liquids, slurries, powder and bulk	Powder and bulk	Powder and bulk	Powder and bulk
<b>Sensing Technology</b>	Capacitance	Capacitance	Vibrating rod	Vibrating tuning fork	Vibrating tuning fork
<b>Wetted Materials</b>	316 SS	CPVC	304 SS	316 SS	304 SS
<b>Temperature Limits</b>	185°F (85°C)	240°F (116°C)	176°F (80°C)	176°F (80°C)	212°F (100°C)
<b>Pressure Limits</b>	365 psi (25 bar)	30 psig (2.06 bar)	150 psi (10 bar)	145 psig (10 bar)	600 psi (40 bar)
<b>Process Connection</b>	3/4", 1", or 1-1/2" male NPT or BSPT or 1-1/2" or 2" sanitary clamp	1" male NPS	1" male NPT	1-1/2" male NPT	1" male NPT
<b>Output</b>	DPDT	SPDT	SPDT	SPDT	PNP/NPN
<b>Mounting Orientation</b>	Vertical or horizontal	Vertical or horizontal	Vertical or horizontal	Vertical or horizontal	Vertical or horizontal
<b>Agency Approvals</b>	CE, cULus	N/A	N/A	N/A	N/A





# SUBMERSIBLE

## Level Transmitters

				
<b>SERIES</b>	<b>SBLT2/SBLTX</b> - page 328	<b>MBLT</b> - page 329	<b>PBLT2/PBLTX</b> - page 330	<b>FBLT</b> - page 331
<b>Service</b>	Liquids	Liquids	Liquids	Liquids
<b>Wetted Materials</b>	316 SS	316 SS	316 SS	316 SS
<b>Temperature Limits</b>	150°F (66°C)	176°F (80°C)	PBLT2: 180°F (82°C) PBLTX: 176°F (80°C)	176°F (80°C)
<b>Pressure Limits</b>	2x FS	2x FS	2x FS	2x FS
<b>Accuracy</b>	±0.25% FS	±0.25% FS	±0.25% FS	±0.25% FS
<b>Range</b>	0 to 300 psi (10 to 693 ft w.c) (3.2 to 211 m w.c)	0 to 300 psi (10 to 693 ft w.c) (3.2 to 211 m w.c)	0 to 300 psi (10 to 693 ft w.c) (3.2 to 211 m w.c)	0 to 300 psi (10 to 693 ft w.c) (3.2 to 211 m w.c)
<b>Output</b>	4 to 20 mA	4 to 20 mA or 0 to 5 V	4 to 20 mA	4 to 20 mA
<b>Agency Approvals</b>	SBLT2: CE SBLTX: CE, cULus	CE	PBLT2: CE PBLTX: CE, cULus	CE

These Selection Guides are for quick comparison of similar products. Please refer to the catalog page number referenced for complete product information and specifications.

# BULK Level Switches

				
<b>SERIES</b>	<b>DBLM</b> - page 324	<b>PLS2</b> - page 324	<b>PLS</b> - page 325	<b>ULTRA-MAG™</b> - pages 326-327
<b>Service</b>	Powder and bulk	Powder and bulk	Powder and bulk	Powder and bulk
<b>Sensing Technology</b>	Rotating paddle	Rotating paddle	Rotating paddle	Magnetic linkage and diaphragm
<b>Wetted Materials</b>	Polycarbonate	304 SS	316 SS	Aluminum or 304 SS with Urethane, Buna-N, PTFE, Silicone Rubber, Polyester, Fluoroelastomer, White Buna-N or EPDM diaphragm
<b>Temperature Limits</b>	140°F (60°C)	176°F (80°C)	300°F (148.9°C)	350°F (176°C)
<b>Pressure Limits</b>	N/A	11.6 psi (0.8 bar)	30 psig (2.07 bar)	60 psig (4.14 bar)
<b>Process Connection</b>	3/4" male NPT, optional flange and 1-1/4" to 3/4" reducer	1-1/4" male NPT	1-1/4" male NPT, optional flange	8-3/8" (212.73 mm) diameter bolt hole circle
<b>Output</b>	SPDT	SPDT	SPDT or DPDT	SPDT
<b>Mounting Orientation</b>	Vertical or horizontal	Vertical or horizontal	Vertical or horizontal	Vertical
<b>Agency Approvals</b>	CE	CE, FM	cUL	CSA, UL

# CAPACITIVE, ULTRASONIC & FLOAT Level Transmitters

				
<b>SERIES</b>	<b>CRF2</b> - page 332	<b>CLT</b> - page 333	<b>ULT</b> - page 334	<b>ULSS/ULSM/ULSL</b> - page 335
<b>Service</b>	Liquids, powders, bulk material	Liquids	Liquids	Fluids/liquids
<b>Wetted Materials</b>	316 SS	Brass	303 SS	PVDF, FKM
<b>Temperature Limits</b>	Ambient: 185°F (85°C), Process: 250°F (121°C)	180°F (82°C) in water, 230°F (110°C) in oil, 230°F (110°C) SS floats	140°F (60°C)	140°F (60°C)
<b>Pressure Limits</b>	100 psi (6.9 bar)	150 psig (10 bar)	30 psi (2 bar)	30 psi (2 bar)
<b>Accuracy</b>	±0.25% FS	±1 mm	±0.2% FS	ULSS: ±0.125" (3 mm); ULSM/ULSL: ±0.2% FS
<b>Range</b>	12 to 30 ft (3.7 to 9.1 m)	Options from .5 to 68" (0.01 to 1.73 m)	0 to 24.6 ft (0 to 7.5 m) or 0 to 32.8 ft (0 to 10 m)	ULSS: 0 to 4.1 ft (0 to 1.25 m); ULSM: 0 to 9.8 ft (0 to 3 m); ULSL: 0 to 18 ft (0 to 5.5 m)
<b>Output</b>	4 to 20 mA	4 to 20 mA or 0 to 5 V	4 to 20 mA	4 to 20 mA
<b>Agency Approvals</b>	N/A	N/A	CE, FM	CE

These Selection Guides are for quick comparison of similar products. Please refer to the catalog page number referenced for complete product information and specifications.

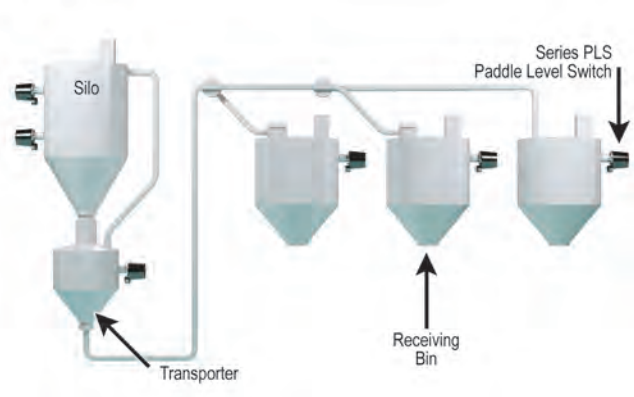

**Proximity® Series PLS is used to indicate level status in pneumatic conveying systems.**

Pneumatic conveying systems use air to transport powder and dry bulk solids through conveying lines. The air is pressurized by positive pressure or vacuum to move the product through the lines into and out of silos, transporters, and receivers. Typical applications have high and low level indication in the storage bins to control the flow of product in or out. The Series PLS is perfect for level use in these storage bins. It has a rotating paddle that is inserted into the bin. As the product level builds up in the bin it stops the paddle from rotating and triggers the level output. The Series PLS is great for this application as it is not affected by pressure changes in the bin.

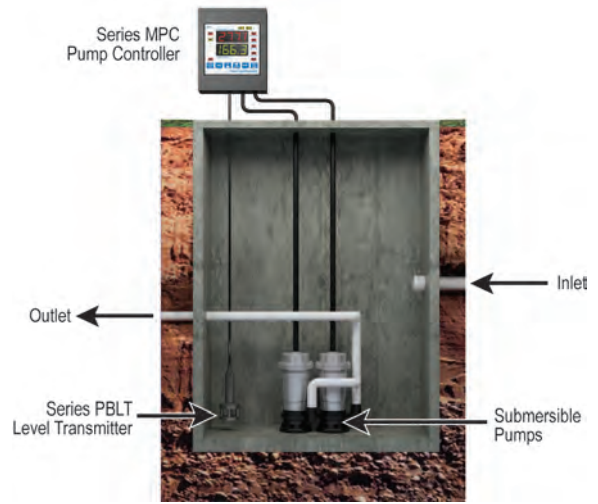

**Mercoid® pump controller with level transmitter control pumps in wastewater lift stations.**

Lift stations are used to transmit wastewater to the treatment facility. Wastewater is transmitted by gravity feed so it has to be continually elevated to provide height to generate the flow. Lift stations are pits located at points in the wastewater system to collect the wastewater that usually have two submersible pumps. Wastewater in the lift station is pumped out to a higher level from where it can flow on to the next lift station or to the treatment facility. The Mercoid® Series MPC pump controller is used with the Series PBLT level transmitter to control the level in the lift station. The Series PBLT is a level transmitter that is submersed in the tank and sends a linear output of the height of wastewater above it. The Series MPC takes the height input and controls the pumps according to how it has been programmed.

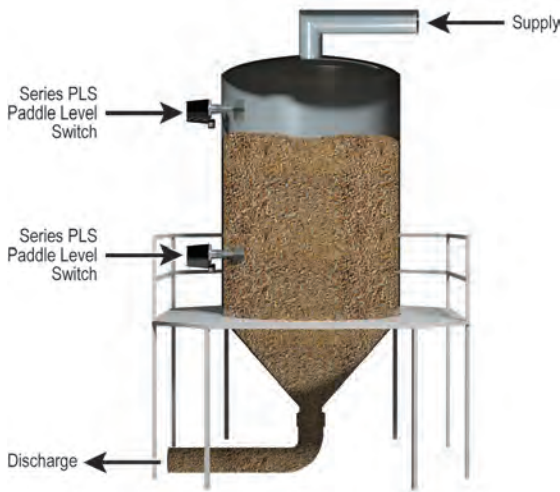

**Grain hopper level controlled by Series PLS Paddle Level Switch.**

The supply of grain pneumatically conveyed to this dispensing hopper is controlled by two Proximity® Series PLS paddle level switches. When the grain level falls to the low limit switch, the supply is turned on until the hopper fills to the level of the high limit switch which turns off the supply. Since grain dust is explosive, the explosion-proof Series PLS provides the required safety protection. The Series PLS is a paddle level switch and is not affected by the varying pressure in the hopper due to the cycling of the pneumatic conveying system.

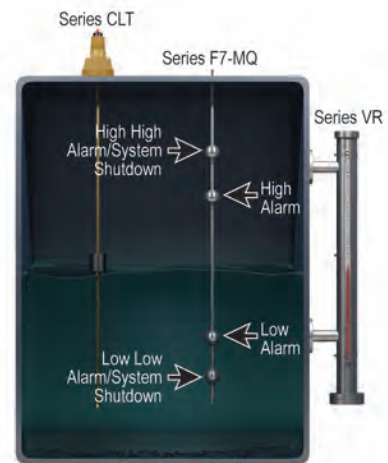

**Custom level sensing devices are built to meet each customer's specific requirements, providing visual indication, continuous measurement, and point level control.**

To meet various tank level measuring needs, Dwyer Instruments, Inc. offers custom-configured products built to customer specifications that provide visual indication, continuous level measurement, and multiple point level measurement. Series VR or MVR View-Rite Level Indicators are a safe way to keep the process isolated while providing true visible indication. Unlike sight glasses, which can crack or break, View-Rite Indicators contain liquids entirely within their stainless steel enclosure. For continuous level measurement needs, the Series CLT uses reed switch technology to offer a more economical solution than expensive ultrasonic, submersible or RT transmitters. Lastly, the Series F7-MQ can be used in virtually any tank to indicate high and low alarms or to control pumps and valves.





**Mercoid® displacer type level control is ideal for controlling industrial sump pumps.**

Industrial sumps and other underground tanks are ideal applications for top-mounted Mercoid® displacer type level controls. Easily installed, these controls use porcelain displacers that do not float on the surface of liquids, but are suspended on a coil spring and cable. As the liquid in the tank reaches the level of the upper displacers, their weight decreases by an amount equal to the liquid displaced, allowing the spring to move the cable upward, actuating the switch and the pump is turned on. As the liquid level falls below the upper displacers they move only a small amount, staying within the switch deadband until the liquid level falls to the center of the bottom displacer. At this point the switch is deactivated stopping the pump. The pump will remain deactivated until the water level rises to the upper displacers, repeating the cycle. The displacers are not affected by turbulence, pressure or chemicals and are excellent for tanks with viscous or dirty liquids. The level differential is easily adjusted by repositioning of the displacers on the 316 SS cable.

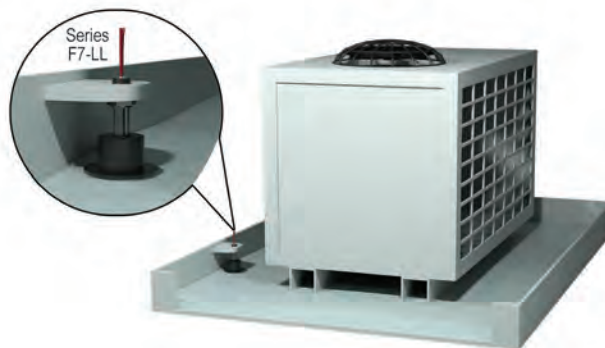

**Low level float switch enables sensing in air conditioner drip pans and other shallow level applications.**

Standard float switches require at least an inch of liquid to attain enough buoyancy to switch. This can be a problem in applications where low level sensing is required. The hat-shaped design of the W.E. Anderson™ Series F7-LL provides necessary buoyancy for switching in only 5/8" of water. This is essential for air conditioner drip pans, low level sumps, and drains. The Series F7-LL is also ideal for low alarms, where running the process dry can result in catastrophic failure.

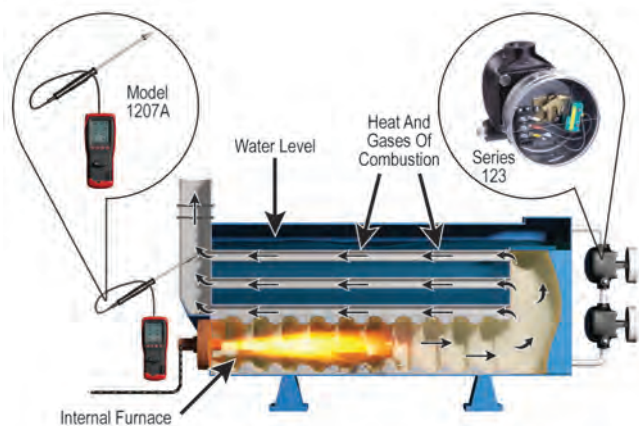

**Mercoid® Series 123 level controls provide high and low alarm on large de-aerator tank.**

Liquid level in the external piping equals level in the tank. When level rises to high limit, float in upper Series 123 is lifted, actuating switch to sound high level alarm. When level drops to low limit, lower Series 123 sounds low level alarm.



**W.E. Anderson™ Series OLS indicates level in heavy equipment radiator.**

Many types of heavy industrial equipment use a liquid cooling system for the motor. A vibratory trench roller is a machine that compacts sub-bases for roads, parking lots, etc., and is an example of the type of equipment that would utilize this system. This machine incorporates a radiator cooling system. In the system, cooling liquid circulates through the engine preventing it from over heating. As the engine is cooled the cooling fluid heats up. The fluid returns to the radiator to cool down before being circulated through again. If there is not enough cooling fluid in the system the engine will not be cooled enough and damage will occur. A W.E. Anderson™ Series OLS optical level switch is installed as a low level alarm. The level alarm is signaled by the Series OLS before the cooling fluid gets to a critical low level, warning the operator of the problem. The Series OLS uses an optical detection system superior for this application as float controls may trip from machine vibration. Also the compact insertion length is ideal for a small radiator.



SERIES VR | W.E. ANDERSON™ BY DWYER

# VIEW-RITE LEVEL INDICATOR

Customized to Fit Any Application, Durable, 316 SS Housing and Float

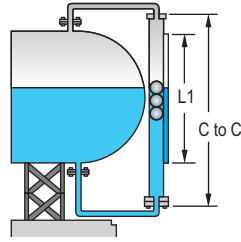

Top & bottom

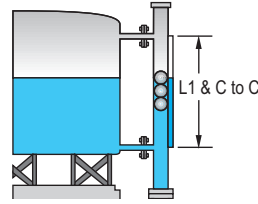

Side & side

TYPICAL MEASUREMENTS	
C to C = L1 + 10.25" (260.35 mm)	C to C = L1

The Series VR View-Rite Level Indicator provides customized level indication to meet a variety of application requirements. Specify any indication length up to 96" (244 cm) and the View-Rite level indicators incorporate a pressure tight housing with internal float that magnetically activates external level indication flags, switches, or transmitter.

**FEATURES/BENEFITS**

- Low maintenance with all 316 L SS wetted material
- Environmentally friendly with process liquid contained inside a pressure-tight housing
- Durable 316 L SS provides maintenance-free operation
- Requires no external power to operate
- Brightly colored flags are easy to read even at long distances

**APPLICATIONS**

- Pharmaceuticals
- Oil and gas
- Medical equipment
- Food and beverages
- Semiconductor manufacturing
- Boilers

**SPECIFICATIONS**

**Service:** Clean, low viscosity liquids.  
**Pressure Limits:** 275 psi (18.9 bar), 225 psi (15.5 bar) @ 100°F (37.8°C), 215 psi (14.8 bar) @ 300°F (148.9°C), 195 psi (13.4 bar) @ 400°F (204.4°C).  
**Tube Diameter:** 2-1/2" (64 mm).

Level Indicators

MODEL CHART														
Example	VR	-S	SS	1	-TP	D	-0.8	-150	-090	-080	P	1	-I	VR-SSS1-TPD-0.8-150-090-080P1-I
Construction	VR													View-rite level indicator
Wetted Materials			S											316 L SS, fluoroelastomer O-ring
Configuration				TB SS										Top/bottom connections Side/side connections
Process Connection					1 2 4 5 6 7									1/2" NPT (female on TB; male on SS configuration) 1" NPT (female on TB; male on SS configuration) 1" 150# RF flange 2" 150# RF flange 1" 300# RF flange 2" 300# RF flange
Float Access					TP BM TB									Top Bottom Top and bottom (only with SS configuration)
Drain and Vent						N D V B								None Drain, 1/2" female NPT (only with SS configuration) Vent, 1/2" female NPT (only with SS configuration) Drain and vent (only with SS configuration)
Specific Gravity							0.0							Specific gravity of fluid: Minimum is 0.8
Operating Pressure								000						Operating pressure in psi: Maximum is 275 psi (18.9 bar)
Operating Temperature									000					Operating temperature of fluid in °F: Maximum is 400°F (204°C)
Indicating Length, L1										000				Indicator length in whole inches: Maximum of 240" (6.1 m); Minimum of 6" (15.25 cm)
Indicating Flags											P A			Plastic, white and orange [300°F (149°C) maximum] Aluminum, silver and black
Visual Indicating Scale												N 1 2		None Feet and inches Inches only
Output Options													I V	4-20 mA transmitter of level [300°F (149°) maximum] 0-5 VDC transmitter of level

Note: Models are built to your specifications

**OPTIONAL SWITCH MODULES**

Model	Description
VR-S1	Maximum temperature is 300°F (148.9°C). Polysulfone with 1/4" female NPT conduit connection.
VR-S2	Maximum temperature is 750°F (399°C). 316 SS with 1/2" male NPT conduit connection.
VR-S3	Maximum temperature is 750°F (399°C). Explosion-proof terminal box with 1/2" female NPT conduit connection.
Clamp onto the level indicator. SPST, rated .17 A @ 120 VAC, .08 A @ 240 VAC, .13 A @ 120 VDC, .06 A @ 240 VDC.	

# MINI VIEW-RITE LEVEL INDICATOR

Customized, Visual Level Indication, Compact Size

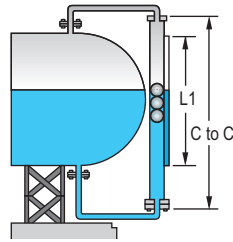

Top & bottom

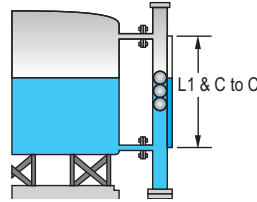

Side & side

TYPICAL MEASUREMENTS	
C to C = L1 + 7.72" (196.09 mm)	C to C = L1

The Series MVR Mini View-Rite Level Indicator provides customized level indication to meet a variety of application requirements in a 1-1/4" (32 mm) housing. Specify any indication length up to 96" (244 cm) and the Mini View-Rite level indicators incorporate a pressure tight housing with internal float that magnetically activates external level indication flags, switches, or transmitter.

### SPECIFICATIONS

**Service:** Clean, low viscosity liquids.  
**Pressure Limits:** ≤ 300°F, 400 psi (27.6 bar); ≥ 300°F, 373 psi (25.7 bar).  
**Tube Diameter:** 1-1/4" (32 mm).

### FEATURES/BENEFITS

- Low maintenance with all 316L SS wetted material
- Environmentally friendly with process liquid contained inside a pressure tight housing
- Durable 316L SS provides maintenance-free operation
- Requires no external power to operate
- Brightly colored flags are easy to read even at long distances

### APPLICATIONS

- Pharmaceuticals
- Medical equipment
- Food and beverages
- Semiconductor manufacturing
- Boilers

### MODEL CHART

Example	MVR	-S	SS	1	-TP	D	-0.8	-150	-090	-080	P	1	-I	MVR-SSS1-TPD-0.8-150-090-080P1-I
Construction	MVR													Mini view-rite level indicator
Wetted Materials		S												316L SS housing, 316L SS float, fluoroelastomer O-ring
Configuration			TB SS											Top/bottom connections Side/side connections
Process Connection				1 3										1/2" NPT (female on TB; male on SS configuration) 1/2" 150# RF flange
Float Access					TP BM TB									Top Bottom Top and bottom (only with SS configuration)
Drain and Vent						N D V B								None Drain, 1/2" female NPT (only with SS configuration) Vent, 1/2" female NPT (only with SS configuration) Drain and vent (only with SS configuration)
Specific Gravity							0.0							Specific gravity of fluid: Minimum is 0.8
Operating Pressure								000						Operating pressure in psi: Maximum is 400 psi (27.6 bar)
Operating Temperature									000					Operating temperature of fluid in °F: Maximum is 400°F (204°C)
Indicating Length, L1										000				Indicator length in whole inches: Maximum of 240" (6.1 m); Minimum of 6" (15.25 cm)
Indicating Flags											P A			Plastic, white and orange [300°F (149°C) maximum] Aluminum, silver and black
Visual Indicating Scale												N 1 2		None Feet and inches Inches only
Output Options												I V		4-20 mA transmitter of level [300°F (149°) maximum] 0-5 VDC transmitter of level

Note: Models are built to your specifications

### OPTIONAL SWITCH MODULES

Model	Description
MVR-S1	Maximum temperature is 300°F (148.9°C). Polysulfone with 1/4" female NPT conduit connection.
MVR-S2	Maximum temperature is 750°F (399°C). 316 SS with 1/2" male NPT conduit connection.
MVR-S3	Maximum temperature is 750°F (399°C). Explosion-proof terminal box with 1/2" female NPT conduit connection.
Clamp onto the level indicator. SPST, rated .17 A @ 120 VAC, .08 A @ 240 VAC, .13 A @ 120 VDC, .06 A @ 240 VDC.	

# WATER LEAK DETECTORS

Battery or External Powered, SPST or DPDT Relays

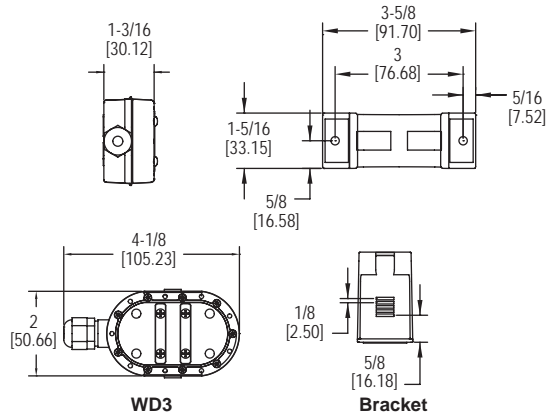
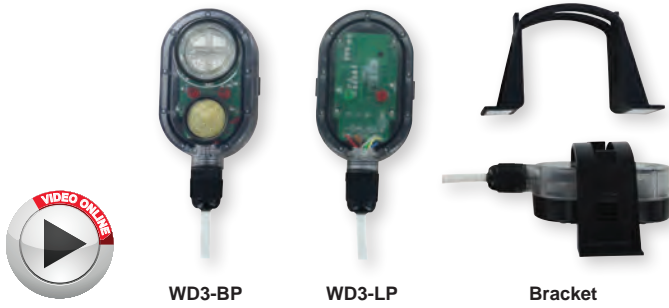

The **Series WD3 Water Leak Detectors** protect equipment from water damage by detecting the presence of water. Model WD3-BP-D1-A is battery powered, all others require AC or DC supply voltages.

**FEATURES/BENEFITS**

- Audible and visual alerts provide local indication of the alarm condition and internal switch will give remote indication or control to prevent further buildup of water
- Sensing height can be adjusted as low as 1/32" (0.79 mm) using the included adjustable mounting bracket
- Mounting bracket can attach to any flat surface by either using the attached adhesive strips or mounting screws for easy installation

**APPLICATIONS**

- AHU drip pans
- Radiant floors
- Data centers
- Sump pumps
- Drains

Model	Output	Power	Audible Alarm
WD3-BP-D1-A	SPST NO SSR	Battery	Yes
WD3-LP-D2	DPDT relay	24 VAC (±10%) or 11 to 27 VDC	No
WD3-LP-D2-A	DPDT relay	24 VAC (±10%) or 11 to 27 VDC	Yes

Model	Description
A-WD3-BRK	Replacement mounting bracket

**SPECIFICATIONS**

**Service:** Water or conductive fluids.  
**Minimum Sensing Gap:** 1/32".  
**Switch Type:** Battery powered model: SPST NO SSR; External powered models: DPDT relay.  
**Electrical Ratings:** Battery powered model: Pilot duty rating 250 mA @ 24 VDC; External powered models: 1 A @ 24 VAC/DC.  
**Audible Alarm:** At least 85 dB @ 1' distance (depends on model).  
**Visual Alarm:** Red LED for water level; Yellow LED for low battery (battery powered model only); Green LED for power condition (external powered models only).  
**Temperature Limits:** 32 to 122°F (0 to 50°C).  
**Power Requirements:** Battery powered model: 3V CR2450 lithium metal battery, installed functional, user replaceable; External powered models: 24 VAC (±10%) or 11-27 VDC.  
**Power Consumption:** Battery powered model: 0.9 mA steady state / 3.0 mA during alarm condition; External powered models: 30 mA steady state / 85 mA during alarm condition.  
**Battery Life:** 5 years steady state / 48 hours during alarm condition.  
**Electrical Connections:** 4.9" (1.5 m), 22 AWG, PVC, UL plenum rated cable.  
**Enclosure Material:** ABS and polycarbonate with flammability classification UL 94 V-0.  
**Enclosure Rating:** Audible alarm models: Watertight up to 3/4 of the body height; Non-audible alarm models: NEMA 6P (IP 68) submersible.  
**Weight:** 4.85 oz (137.5 g).  
**Agency Approvals:** CE.

Water Leak Detectors

SERIES WD | W.E. ANDERSON™ BY DWYER

# WATER DETECTOR AND SENSOR TAPE

Detects Low Levels Of Conductive Liquids, Large Measuring Area

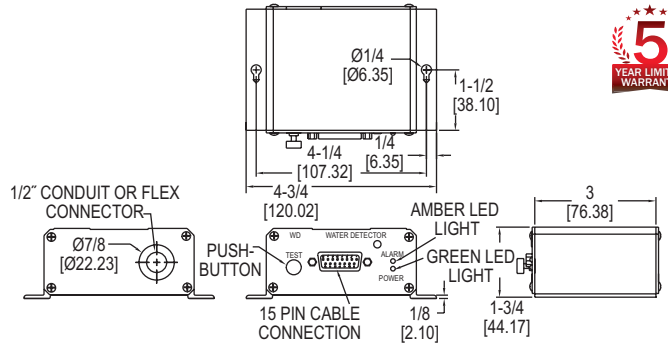

The **Series WD Water Detector and Sensor Tape** is designed for dependable detection of water presence even of low conductive liquids. The water sensing tape attaches to module and if any liquid comes in contact with the tape the resistance is changed and the alarm will be triggered. The sensing tape is 1" wide and can be bought in lengths of 5, 10, 15 and 25' and is powered by 24 VAC or 24-30 VDC.

**FEATURES/BENEFITS**

- Sturdy and reliable aluminum enclosure
- Hydrophobic tape does not absorb any liquid allowing for faster drying time and faster return to service after water leak
- Multiple tapes can be connected together to extend the coverage area

**APPLICATIONS**

- Drip pans under HVAC equipment
- Computer rooms
- Telecommunication facilities
- Leak detection around water pumps

**SPECIFICATIONS**

**Service:** Conductive liquid.  
**Switch Type:** DPDT.  
**Electrical Rating:** 1 A @ 24 VAC/VDC.  
**Power Requirements:** 24 VAC, 24-30 VDC.  
**Power Consumption:** 35 mA maximum.  
**Electrical Connections:** Screw terminals.  
**Conduit Connections:** Hole for 1/2" conduit.  
**Enclosure:** Extruded aluminum.  
**Sensor Tape:** 1" (25.4 mm) wide and 5', 10', 15' or 25' long.  
**Weight:** 8 oz (.23 kg).

Model	Description
WD	Water module
TP05	5' (1.52 m) tape
TP10	10' (3.05 m) tape
TP15	15' (4.57 m) tape
TP25	25' (7.62 m) tape



# FLOTECT® FLOAT SWITCH

Magnetically Operated Switch, Leak Proof Body, Explosion-Proof

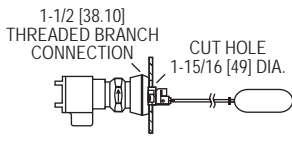

Standard installation

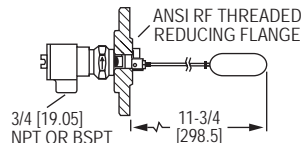

Horizontal, flange installation

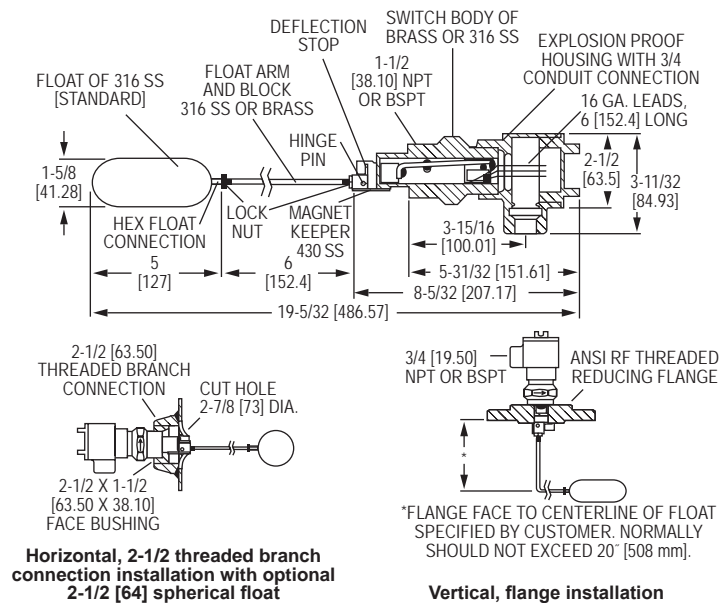

Horizontal, 2-1/2 threaded branch connection installation with optional 2-1/2 [64] spherical float

Vertical, flange installation

\*FLANGE FACE TO CENTERLINE OF FLOAT SPECIFIED BY CUSTOMER. NORMALLY SHOULD NOT EXCEED 20" [508 mm].



The Series L4 FloTECT® Float Switch is a rugged and reliable float switch which operates automatically to indicate tank level.

**FEATURES/BENEFITS**

- Unique magnetically actuated switching design gives superior performance
- No bellows, springs, or seals to fail
- Free-swinging float attracts a magnet within the solid metal switch body, actuating a snap switch by means of a simple lever arm
- Float arm hinge design limits the arm angle to prevent vertical hang up

**APPLICATIONS**

- Direct pump control for maintaining level
- Automatic tank dump operations
- Level control
- Valve control
- Level alarm in sumps, scrubber systems, hydro-pneumatic tanks, boilers, and water/wastewater treatment processes

OPTIONS	
To order add suffix:	Description
-D	DPDT contacts
-NH	No housing
-MV	Gold plated contacts for dry circuits (see electrical rating in specifications, no listings or approvals)
-MT	High temperature rated 400°F (204°C) (see electrical rating in specifications, no listings or approvals)
-TRI	Time delay relay with 2 SPDT contacts, adjustable from 0-1 to 0-31 minutes (increasing flow)
-TRD	Time delay relay with 2 SPDT contacts, adjustable from 0-1 to 0-31 minutes (decreasing flow) (no listings or approvals)
-316	*316 SS magnet keeper option to replace standard 430 SS
-AT	ATEX compliant construction
-IEC	IECEx certified construction
-TOP	Top mounted for vertical flange installation [distance from flange face to centerline of float to be specified, 20" (508 mm) max]
-50	Optional float (2-1/2" spherical) 304 SS rated 50 psig (3.5 bar) and 0.5 min. s.g.
-150	Optional float (2-1/2" spherical) 316 SS rated 150 psig (10.3 bar) and 0.7 min. s.g.
-300	Optional float (2-1/2" spherical) 304 SS rated 300 psig (20.7 bar) and 0.7 min. s.g.
-BSPT	1-1/2" female BSPT process connection

\*316 SS body and float with 430 SS magnet keeper (wetted part).  
Consult factory for price and availability of fittings for L4 installation. Threaded branch connection, bushings, and flanges are available in a variety of sizes and materials.

**SPECIFICATIONS**

**Service:** Liquids compatible with wetted materials.  
**Wetted Materials:** Float and Rod: 316 SS; Body: Brass or 316 SS standard; Magnet Keeper: 430 SS standard, 316 SS or nickel optional.  
**Temperature Limits:** 4 to 275°F (-20 to 135°C) standard, MT high temperature option 400°F (205°C) [MT option not UL, CSA, ATEX or IECEx]. ATEX and IECEx options: Ambient temperature -4 to 163°F (-20 to 73°C); Process temperature -4 to 163°F (-20 to 73°C).  
**Pressure Limit:** Brass body 1000 psig (69 bar), 316 SS body 2000 psig (138 bar). Standard float rated 100 psig (6.9 bar). For other floats, see options.  
**Enclosure Rating:** Weatherproof and Explosion-proof. \*\*Listed with UL and CSA for Class I, Groups C and D; Class II, Groups E, F, and G. ATEX C 0344 II 2 G Ex d IIB T6 Gb -20°C≤Tamb≤73°C. -20°C≤Process Temps≤73°C.  
 EC-Type Certificate No.: KEMA 03 ATEX 2383.  
 ATEX Standards: EN60079-0: 2009; EN60079-1: 2007.  
 IECEx Certified: For Ex d IIB T6 Gb -20°C≤Tamb≤73°C. -20°C≤Process Temps≤73°C.  
 IECEx Certificate of Conformity: IECEx DEK 11.0071.  
 IECEx Standards: IEC 60079-0: 2007; IEC 60079-1: 2007.  
**Switch Type:** SPDT snap switch standard, DPDT snap switch optional.  
**Electrical Rating:** UL, FM, ATEX and IECEx models: 10 A @ 125/250 VAC (V-). CSA models: 5 A @ 125/250 VAC (V-); 5 A res., 3 A ind. @ 30 VDC (V-). MV option: 1 A @ 125 VAC (V-); 1 A res., .5 A ind. @ 30 VDC (V-). MT option: 5 A @ 125/250 VAC (V-). [MT and MV option not UL, CSA, FM, ATEX or IECEx].  
**Electrical Connections:** UL and CSA models: 16 AWG, 6" (152 mm) long. ATEX and IECEx unit: terminal block.  
**Conduit Connection:** 3/4" (19.05 mm) female NPT standard or M25 with -BSPT option.  
**Process Connection:** 1-1/2" (38.10 mm) male NPT or 1-1/2" (38.10 mm) male BSPT standard, 2-1/2" (63.50 mm) male NPT or 2-1/2" (63.50 mm) male BSPT standard optional floats.  
**Mounting Orientation:** Horizontal installation standard, optional vertical top mount.  
**Dead Band:** 3/4" (19 mm) for standard float.  
**Specific Gravity:** 0.7 minimum with standard float. For other floats see model chart.  
**Weight:** 4 lb 9 oz (2.07 kg).  
**Agency Approvals:** ATEX, CE, CSA, FM, IECEx, UL\*\*.

\*\*No housing option (-NH) has no approvals.

MODEL CHART		
Model	Description	Process Connection
L4	Brass body, side wall mounting	NPT
L4-NH**	Brass body, side wall mounting, no housing	NPT
L4-SS	316 SS* body, sidewall mounting	NPT
L4-SS-NH**	316 SS* body, sidewall mounting, no housing	NPT
L4-BSPT	Brass body, side wall mounting	BSPT
L4-SS-BSPT	316 SS* body, sidewall mounting	BSPT

\*316 SS body and float with 430 SS magnet keeper (wetted part).  
 \*\*No housing option (-NH) has no approvals.

USA: California Proposition 65  
 ⚠️WARNING: Cancer and Reproductive Harm - www.P65Warnings.ca.gov



SERIES L6 | W.E. ANDERSON™ BY DWYER



# FLOTECT® LIQUID LEVEL SWITCHES

Easy In-wall or External Installation, Up to 2000 psig (138 bar), Compact Size

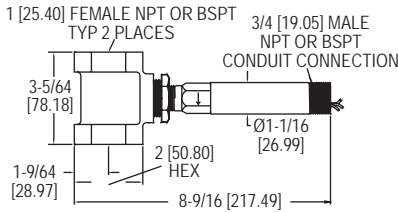
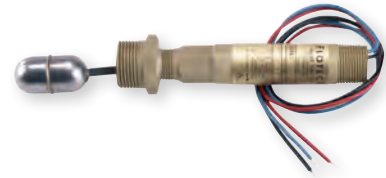

Model L6 with external float chamber

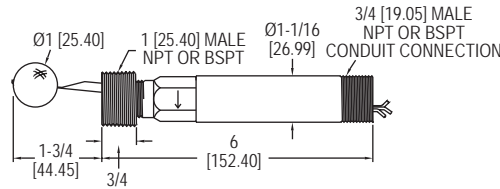

Model L6 with spherical float

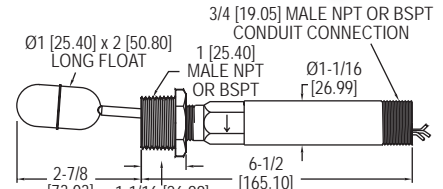

Model L6 with cylindrical float



The **Series L6 FloTECT® Liquid Level Switches** are rugged and reliable float switches which operates automatically to indicate tank level. It is offered with a 303 SS or brass body with spherical or cylindrical float options.

**FEATURES/BENEFITS**

- Compact design is built for years of trouble-free service
- Simple and dependable operation with no mechanical linkage
- Float lever pivoted within the body moves when the process liquid displaces the float and magnet on the opposite end of the float lever controls a second magnet on the switch actuating lever located in the switch housing
- Leak proof lower body machined from bar stock
- Side wall or direct tee mounting options available to act as an external float chamber
- Weatherproof and explosion-proof body for demanding outdoor applications
- Electrical assembly can be easily replaced without removing the unit from the installation so that the process does not have to be shut down
- Sensitive to level changes of less than 1/2" (12 mm)

**APPLICATIONS**

- Direct pump control for maintaining level
- Automatic tank dump operations
- Level control
- Valve control
- Level alarm in sumps, scrubber systems, hydro-pneumatic tanks, boilers, and water/wastewater treatment processes

OPTIONS	
To order add suffix:	Description
-MV	Gold plated contacts for dry circuits (see electrical rating in specifications)
-MT	High temperature rated 400°F (204°C) (see electrical rating in specifications, no listings or approvals, only available on models with stainless steel floats)
-CSA	CSA and UL approved construction, includes weatherproof and explosion-proof junction box
-AT	ATEX compliant construction includes, weatherproof and explosion-proof, junction box
-IEC	IECEX certified construction

**Note:** M25 is not available with the CSA housing.

**DPDT Contacts**

**Note:** To order, change seventh character in model number to "D". **Example:** L6EPB-B-D-3-O

**Options Not Shown:** 1-1/2" and 2" (38.10 and 50.80 mm) male NPT or 1-1/2" and 2" (38.10 and 50.80 mm) male BSPT process connection, 2" female NPT or 2" female BSPT.

MODEL CHART						
Model	Body	Installation	Float Material	Process Connection	Max. Pressure psig (bar)	Min. S.G.
L6EPB-B-S-3-O	Brass	Side wall mounting	Polypropylene spherical	NPT	1000 (69)	0.9
L6EPB-B-S-3-A	Brass	Side wall mounting	304 SS cylindrical	NPT	200 (13.8)	0.5
L6EPB-B-S-3-C	Brass	Side wall mounting	304 SS spherical	NPT	350 (24.1)	0.7
L6EPB-B-S-3-B	Brass	Brass external float chamber (tee)	Polypropylene spherical	NPT	250 (17.2)	0.9
L6EPB-B-S-3-H	Brass	Brass external float chamber (tee)	304 SS spherical	NPT	250 (17.2)	0.7
L6EPS-S-S-3-O	303 SS	Side wall mounting	Polypropylene spherical	NPT	2000 (138)	0.9
L6EPS-S-S-3-A	303 SS	Side wall mounting	304 SS cylindrical	NPT	200 (13.8)	0.5
L6EPS-S-S-3-C	303 SS	Side wall mounting	304 SS spherical	NPT	350 (24.1)	0.7
L6EPS-S-S-3-S	303 SS	304 SS external float chamber (tee)	Polypropylene spherical	NPT	2000 (138)	0.9
L6EPS-S-S-3-L	303 SS	304 SS external float chamber (tee)	304 SS spherical	NPT	350 (24.1)	0.7

BSPT process connection and M25 conduit connection. **Note:** To order, change eighth character in model to "4". **Example:** L6EPB-B-S-4-A

**SPECIFICATIONS**

**Service:** Liquids compatible with wetted materials.  
**Wetted Materials:** Float: Solid polypropylene or 304 SS; Lower Body: Brass or 303 SS; Magnet: Ceramic; External Float Chamber (Tee): Matches lower body choice of brass or 303 SS; Other: Lever Arm, Spring, Pin, etc.: 301 SS.  
**Temperature Limit:** -4 to 220°F (-20 to 105°C) Standard, MT high temperature option 400°F (205°C)(MT not UL, CSA, ATEX, IECEx and KC). ATEX compliant AT, IECEx IEC and KC option ambient temperature -4 to 167°F (-20 to 75°C) process temperature: -4 to 220°F (-20 to 105°C).  
**Pressure Limits:** See model chart.  
**Enclosure Rating:** Weatherproof and Explosion-proof. Listed with UL and CSA for Class I, Groups A, B, C and D; Class II, Groups E, F, and G. (Group A on stainless steel body models only).  
 ATEX  $\text{CE}$  0344  $\text{Ex}$  II 2 G Ex d IIC T6 Gb Process Temp $\leq$ 75°C. EC-Type Certificate No.: KEMA 04ATEX2128.  
 ATEX Standards: EN 60079-0: 2009; EN60079-1: 2007.  
 IECEx Certified: For Ex d IIC T6 Gb Process Temps 75°C.  
 IECEx Certificate of Conformity: IECEx DEK II.0039.  
 IECEx Standards: IEC 60079-00: 2007; IEC 60079-1: 2007.  
 Korean Certified (KC) for Ex d IIC T6 Gb Process Temps $\leq$ 75°C.  
 KTL Certificate Number: 2012-2454-75.  
**Switch Type:** SPDT snap switch standard, DPDT snap switch optional.  
**Electrical Rating:** UL models: 5 A @ 125/250 VAC (V~). CSA and IECEx models: 5 A @ 125/250 VAC (V~); 5 A res., 3 A ind. @ 30 VDC (V-). MV option: .1 A @ 125 VAC (V~). MT option: 5 A @ 125/250 VAC (V~). [MT option not UL, CSA, ATEX or IECEx].  
**Electrical Connections:** UL models: 18 AWG, 18" (457.20 mm) long. ATEX/CSA/IECEX models: terminal block.  
**Upper Body:** Brass or 303 SS.  
**Conduit Connection:** 3/4" (19.05 mm) male NPT standard, 3/4" (19.05) female NPT or M25 with BSPT option on junction box models.  
**Process Connection:** 1" (25.40 mm) male NPT or 1" (25.40 mm) male BSPT on models without external float chamber, 1" (25.40 mm) female NPT or 1" (25.40 mm) female BSPT on models with external float chamber.  
**Mounting Orientation:** Horizontal with index arrow pointing down.  
**Specific Gravity:** See chart.  
**Weight:** Approximately 1 lb (.5 kg) without external float chamber, 1.75 lb (.8 kg) with external float chamber.  
**Agency Approvals:** ATEX, CE, CSA, IECEx, KTL, UL.

Level Switches, Float

# FLOTECT® LIQUID LEVEL SWITCHES

Low Cost, Leak Proof Body, Excellent Chemical Resistance

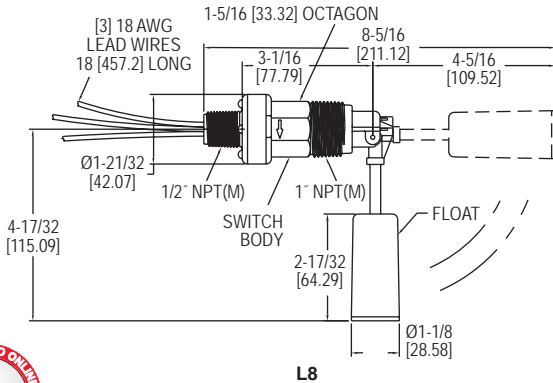

L8

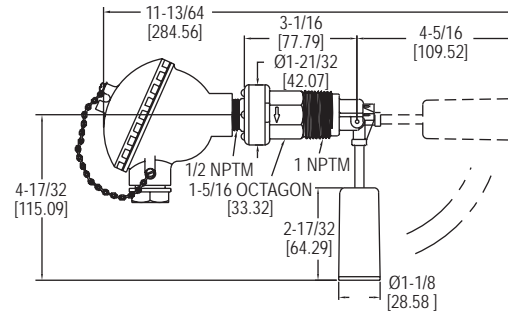

L8-WP2



The **Model L8 Flotect® Liquid Level Switches** are float switches constructed of polyphenylene sulfide, Ceramic 8 and 316 SS. This liquid level switch provides accurate set point control of liquids with specific gravities as low as 0.6.

**FEATURES/BENEFITS**

- Features a leak proof body and float constructed from tough, durable polyphenylene sulfide which has excellent chemical resistance
- Liquid level snap switch is magnetically actuated with no direct mechanical linkage to leak or fail, assuring longer life and decreased maintenance costs
- Quick and easy installation with simple placement of the unit in a horizontal position with the index arrow pointing down
- UL recognized as an industrial motor controller per UL standard 508, suitable for mounting in a protected environment

**APPLICATIONS**

- Environmental control
- Waste water
- Scrubber systems
- Holding tanks
- Cooling towers
- Chemical/petroleum processing
- Plating and washing tanks
- Sewage treatment
- Car washes
- Remediation systems
- Thermal storage systems
- HVAC and building automation systems

**SPECIFICATIONS**

**Service:** Compatible liquids.  
**Wetted Materials:** Float and body: Polyphenylene sulfide (PPS); Pin and spring: 316 SS or Inconel®; Magnet: Ceramic 8.  
**Temperature Limit:** 212°F (100°C).  
**Pressure Limit:** 150 psig (10.34 bar).  
**Enclosure Rating:** General purpose. WP/WP2 option is weatherproof.  
**Switch Type:** SPDT snap switch. MV option is a SPDT gold contact snap switch.  
**Electrical Rating:** 5 A @ 125/250 VAC, 5 A resistive, 3 A inductive @ 30 VDC. MV option: 1 A @ 125 VAC, 1 A resistive, 0.5 A inductive @ 30 VDC.  
**Electrical Connections:** 18 AWG, 18" (460 mm) long.  
**Conduit Connection:** 1/2" male NPT, 1/2" female NPT on WP and WP2.  
**Process Connection:** 1" male NPT.  
**Mounting Orientation:** Horizontal with index arrow pointing down.  
**Weight:** 5 oz (0.142 kg).  
**Specific Gravity:** 0.6 minimum.  
**Agency Approvals:** CE, cURus.

**MODEL CHART**

Model	Description
L8	Level switch

**OPTIONS**

To order add suffix:	Description
-MV	Gold plated contacts for dry circuits. Rated 1 A @ 125 VAC; 1 A resistive, 0.5 A inductive @ 30 VDC
<b>Example:</b> L8-MV	
-INC	Inconel® alloy. Inconel® alloy replaces standard 316 SS wetted parts. Wetted parts are Inconel® Alloy, Ceramic 8, and Polyphenylene Sulfide.
<b>Example:</b> L8-INC	
-WP	Weatherproof enclosure. Optional housing is phenylpolioxide and provides weatherproof protection for electrical wiring. (Not UL approved)
<b>Example:</b> L8-WP	
-WP2	Weatherproof enclosure. Optional housing is aluminum and provides weatherproof protection for electrical wiring. (Not UL approved)
<b>Example:</b> L8-WP2	





SERIES L10 | W.E. ANDERSON™ BY DWYER



# FLOTECT® MINI-SIZE LEVEL SWITCH

Easy In-wall or External Installation, Specific Gravities as Low as 0.5

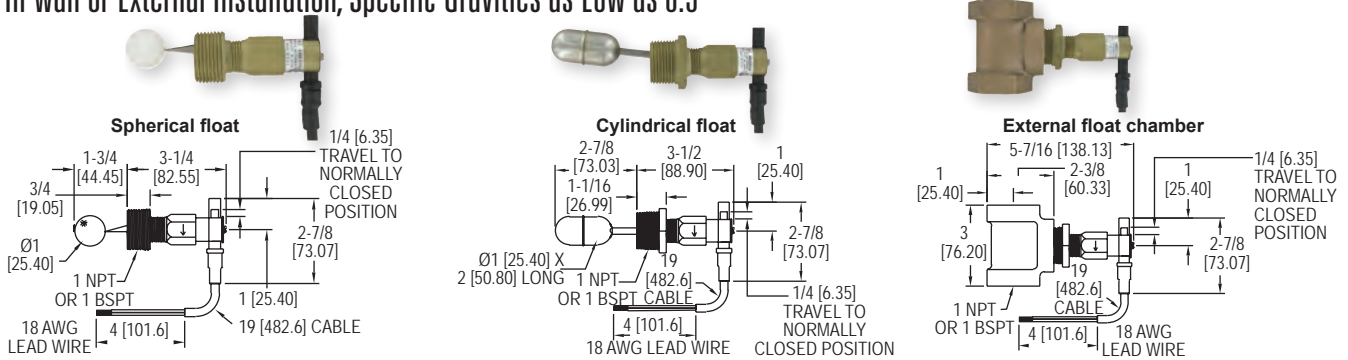

The **Series L10 FloTECT® Mini-Size Float Switch** is a series of economical, compact liquid level floats. It is offered in brass or 303 SS bodies and external tees as well as polypropylene or 304 SS floats with 1" NPT male threads, for direct side mounting through a half coupling, or with factory installed tee for external mounting. This series can be used in liquids with specific gravities as low as 0.5.

**FEATURES/BENEFITS**

- Hermetically sealed, magnetically actuated SPST reed switch which is encapsulated in a polypropylene housing
- Simple field switch adjustment allows user to toggle between normally open (NO) or normally closed (NC) with no change in the electrical connection
- Switch is easily replaced without affecting process installation for quick and low cost maintenance
- Combines low cost with top quality materials and construction for great value and years of reliable liquid level control

**APPLICATIONS**

- Direct pump control for maintaining level
- Automatic tank dump operations
- Level control
- Valve control

**SPECIFICATIONS**

**Service:** Compatible liquids.  
**Wetted Materials:** Float: Solid polypropylene or 304 SS; Body: Brass or 303 SS; Magnet: Ceramic; External float chamber (tee): None, brass, or 304 SS; Other: Lever arm, pin, spring, etc.: 301 SS, 302 SS, 316 SS.  
**Temperature Limit:** 200°F (93°C).  
**Pressure Limit:** Brass body: See chart; 303 SS body: Polypropylene float: 2000 psig (137.8 bar), Cylindrical float: 200 psig (13.8 bar), Spherical float: 350 psig (24.1 bar).  
**Enclosure Rating:** Weatherproof, meets NEMA 4X (IP66).  
**Switch Type:** SPST hermetically sealed reed switch. Field adjustable for NO or NC.  
**Electrical Rating:** 1.5 A @ 24 VDC res., 0.001 A @ 200 VDC res., 0.5 A @ 120 VAC.

**Electrical Connections:** 18 AWG, 19" (483 mm) long, PVC jacket. Rated 221 V<sup>F</sup> (105°C).  
**Process Connection:** 1" male NPT or 1" male BSPT on models without external float chamber. Change 3 in model number to 4 for 1-1/4", to 5 for 1-1/2", or 6 for 2". 1" female NPT or 1" female BSPT on models with external float chamber.  
**Mounting Orientation:** Horizontal with index arrow pointing down.  
**Specific Gravity:** See chart.  
**Switch Enclosure:** Nylon.  
**Weight:** Approximately 10 oz (0.283 kg) without external float chamber, 2.32 lb (1.05 kg) with external float chamber.  
**Agency Approvals:** CE, CSA and UR.

**MODEL CHART**

Model	Installation	Float Material	Process Connection	Max. Pressure psig (bar)	Min. S.G.
L10-B-3-O	Side wall mounting	Polypropylene spherical	NPT	1000 (69)	0.9
L10-B-3-A	Side wall mounting	304 SS cylindrical	NPT	200 (13.8)	0.5
L10-B-3-C	Side wall mounting	304 SS spherical	NPT	350 (24.1)	0.7
L10-B-3-B	Brass tee	Polypropylene spherical	NPT	250 (17.2)	0.9
L10-B-3-H	Brass tee	304 SS spherical	NPT	250 (17.2)	0.7

**OPTIONS**

**BSPT Process Connection and M25 Conduct Connection**  
**Note:** To order, add "-BSPT" to the end of the model number.  
**Example:** L10-B-3-O-BSPT  
**303 SS Body**  
**Note:** To order, change fourth character to "S". **Example:** L10-S-3-O

USA: California Proposition 65

⚠WARNING: Cancer and Reproductive Harm - www.P65Warnings.ca.gov

MODEL F7-MLK | W.E. ANDERSON™ BY DWYER

# MULTI-LEVEL SWITCH KIT

One or Two Station Level Switch, Vertically Mount

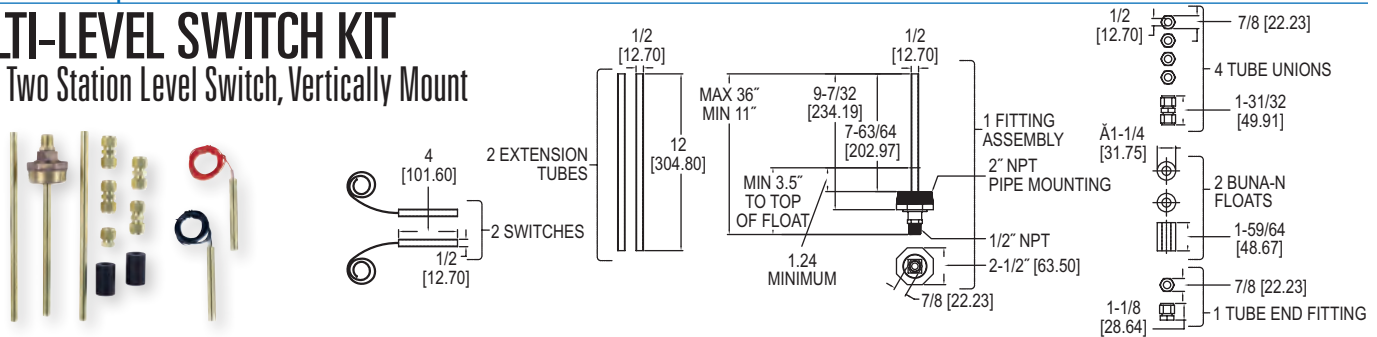

The **Model F7-MLK Multi-Level Switch Kit** provides a customized level system to suit specific application requirements. The F7-MLK Multi-Level Switch Kit contains all the components necessary for the design and fabrication of a 1 or 2 station level switch for pipe plug mounting.

**FEATURES/BENEFITS**

- Customize stem length (max.: 36"; min.: 11"), actuation point, distance between floats, and lead wire lengths
- Includes two level stations (switch, tube, and Buna-N float), two brass extension tubes 12" length, four brass tube unions, one end fitting, and one mounting plug

**APPLICATIONS**

- General purpose level monitoring
- Low specific gravity
- Gas and oil

**SPECIFICATIONS**

**Service:** Compatible liquids.  
**Wetted Materials (Float/Stem):** Buna-N/Brass.  
**Temperature Limits:** 221°F (105°C).  
**Pressure Limits:** 150 psig (10 bar).  
**Switch Type:** SPST, NO or NC.  
**Electrical Rating:** 60 Watts: 0.4 A @ 220 VAC, 0.5 A @ 110 VAC, 0.2 A @ 120 VDC, 0.5 A @ 24 VDC.  
**Electrical Connections:** 22 AWG x 72" (183 cm) leads.  
**Note:** Top floats 3.5" (8.89 cm) min. distance.

**Process Connection:** 2" male NPT pipe plug.  
**Mounting Orientation:** Up to 30° angle from vertical.  
**Stem Length:** 36" (91 cm) max.; 11" (27.94 cm) min.  
**Tube/Fitting Size:** 1/2" OD.  
**Minimum Specific Gravity:** 0.45.  
**Weight:** 3.5 lb (1.6 kg).

**MODEL CHART**

Model	Description
F7-MLK	Multi-level switch kit

**Note:** 316 SS version also available, please see F7-MLK2 on Dwyer website.

USA: California Proposition 65

⚠WARNING: Cancer and Reproductive Harm - www.P65Warnings.ca.gov







SERIES F6 & F7 | W.E. ANDERSON™ BY DWYER



# LEVEL SWITCHES - VERTICAL

Low Cost, Reliable and Compact, Hermetically Sealed Contacts



F7-SB



F7-ST713

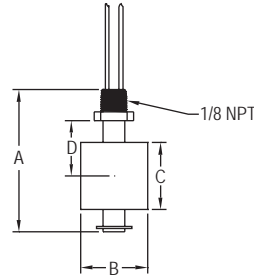

DIMENSIONS - IN (MM)				
Model	(A) Stem Length	(B) Float Diameter	(C) Float Height	(D) Actuation from Hex <sup>Ⓢ</sup>
F7-SB	2.75 (70)	1.38 (35)	1.13 (29)	1.2 (31)
F7-SS2	2.06 (52)	1.0 (25)	1.0 (25)	0.73 (19)
F6-SS	2.17 (55)	1.11 (28)	1.11 (28)	–
F7-MPP	1.63 (41)	0.63 (16)	0.63 (16)	0.47 (12)
F7-PP	2.18 (55)	1.18 (30)	1.0 (25)	0.69 (18)
F7-BT	2.18 (55)	1.18 (30)	1.0 (25)	0.69 (18)
F7-K	2.13 (54)	1.0 (25)	1.0 (25)	0.65 (17)
F7-C11	2.06 (52)	1.0 (25)	1.0 (25)	0.56 (14)
F7-C21	2.06 (24)	1.0 (25)	1.0 (25)	0.56 (14)
F7-PVC	3.44 (87)	1.5 (38)	1.81 (46)	0.75 (19)
F7-T1	3.47 (88)	2.13 (54)	1.94 (49)	0.92 (22)
F7-ST713	3.38 (86)	2.06 (52)	2.06 (52)	1.09 (28)
F7-ST714	3.38 (86)	2.06 (52)	2.06 (52)	1.09 (28)

<sup>Ⓢ</sup>Distance between hex and liquid (S.G. = 1.0) level at actuation point will vary with specific gravity changes.

The Series F6 & F7 Vertical Level Switches are designed to be mounted at the maximum or minimum level point to provide level indication and control. Models are shipped with normally open switch contacts which close as the float rises toward the mounting threads.

**FEATURES/BENEFITS**

- Combine low cost and reliability with fast, simple installation
- Hermetically sealed reed switches are actuated by magnets permanently bonded inside the float and can be easily adapted to open or close a circuit on rising or falling levels
- Easily reverse switch action by removing the float, rotating it end-for-end and replacing it on the stem
- Vertical models mount internally, oriented within 30° of vertical, or select optional fittings for external mounting
- Switch ratings are suitable for many solid state control systems and monitors or alarms
- Simple relay interfaces can be used for higher current applications

**APPLICATIONS**

- Water level monitoring
- Oil level control
- Chemical level indication
- Sumps
- Stand pipes
- Tank level control
- High viscosity liquids

**ACCESSORIES - FOR EXTERNAL MOUNTING OF VERTICAL MODELS**

Model	Description
A-347	1/8" x 1-1/4" NPT carbon steel adapter
A-347-SS	1/8" x 1-1/4" NPT 316 SS adapter
A-348	1/8" x 1-1/2" NPT carbon steel adapter

Level Switches, Float

MODEL CHART									
Model	Applications	Material Float/Stem	Temp. Limits	Pressure Limits	Min. S.G.	Electrical Rating	Wire Leads	Mtg NPT (M)	Weight oz (g)
F7-SB*	General purpose	Buna-N & epoxy/ 316 SS	220°F (105°C)	150 psig 10 bar	0.60	25 VA: 1 A @ 220 VAC	22 AWG 18" (45 cm)	1/8"	2 (58)
F7-SS2*	High temp/pressure, corrosives	316 SS (CYC)/ 316 SS	300°F (149°C)	450 psig 31 bar	0.75	25 VA: 1 A @ 200 VAC	22 AWG 18" (45 cm)	1/8"	1.2 (34)
F6-SS	Corrosives	316 SS/ 316 SS	257°F (125°C)	218 psig 15 bar	0.65	20 VA: 0.08 A @ 240 VAC	20 AWG 11.8" (30 cm)	1/8"	1.59 (45)
F7-MPP**	Broad chemical compatibility	Polypropylene/ polypropylene	180°F (82°C)	100 psig 6.89 bar	0.90	10 VA: 0.1 A @ 100 VAC	22 AWG 24" (61 cm)	1/8"	0.8 (23)
F7-MPP-NO**	Broad chemical compatibility	Polypropylene/ polypropylene	176°F (80°C)	100 psig 6.89 bar	0.90	50 VA: 0.2 A @ 240 VAC	22 AWG 24" (61 cm)	1/8"	0.8 (23)
F7-PP*	Broad chemical compatibility	Polypropylene & epoxy/polypropylene	220°F (105°C)	100 psig 6.89 bar	0.60	30 VA: 0.14 A @ 220 VAC	22 AWG 24" (61 cm)	1/8"	0.8 (23)
F7-BT*	Oils & fuels	Buna-N & epoxy/ PBT***	220°F (105°C)	150 psig 10 bar	0.45	30 VA: 0.14 A @ 220 VAC	22 AWG 24" (61 cm)	1/8"	0.7 (20)
F7-K*	Food/beverage, corrosives	PVDF/ PVDF	180°F (82°C)	100 psig 6.89 bar	1.00	50 VA: 0.25 A @ 150 VAC	22 AWG 24" (61 cm)	1/8"	1.5 (43)
F7-C11	General purpose	Buna-N/ brass	180°F (82°C)	150 psig 10 bar	0.45	20 VA: 0.08 A @ 240 VAC	22 AWG 24" (61 cm)	1/8"	1.5 (43)
F7-C21*	Oils & water, general purpose	Buna-N/ 316 SS	180°F (82°C)	150 psig 10 bar	0.45	20 VA: 0.08 A @ 240 VAC	22 AWG 24" (61 cm)	1/8"	1.5 (43)
F7-PVC	Chemical & plating	CPVC/ CPVC	180°F (82°C)	15 psig 1 bar	0.85	20 VA: 0.08 A @ 240 VAC	22 AWG 24" (61 cm)	1/4"	5 (140)
F7-T1	Viscous, sticky or corrosive liquids	PTFE/ TFE	300°F (149°C)	30 psig 2 bar	0.80	20 VA: 0.08 A @ 240 VAC	22 AWG 24" (61 cm)	1/4"	6 (170)
F7-ST713	Oils, water & chemicals	316 SS/ 316 SS	300°F (149°C)	750 psig 52 bar	0.80	20 VA: 0.08 A @ 240 VAC	22 AWG 24" (61 cm)	1/4"	6 (170)

\*UL listed    \*\*F7-MPP is normally closed/F7-MPP-NO is normally open    \*\*\*PBT-Polybutylene terephthalate

USA: California Proposition 65  
 ⚠WARNING: Cancer and Reproductive Harm - www.P65Warnings.ca.gov

# QUICK-SHIP MULTI-STATION LEVEL SWITCH

Fast Delivery, Customized, Up to Four Actuation Levels

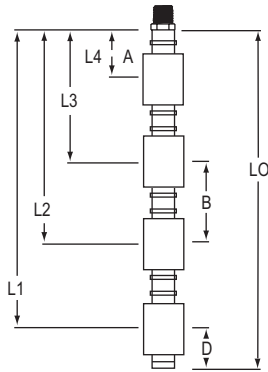

ACTUATION LEVELS		
A	B	D
1-1/2" (38.10 mm)	3" (76.20 mm)	2" (50.80 mm)
Each switching point requires one float.		
A=Minimum distance from actuation point to bottom of mounting		
B=Minimum distance between actuation levels		
D=Minimum distance from end of unit to lowest actuation point		

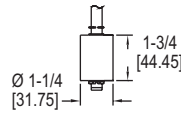

F1 float dimensions

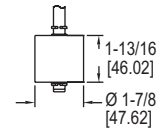

F2 float dimensions

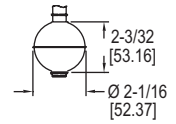

F3 float dimensions

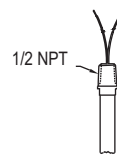

Type 1 mounting dimensions

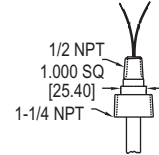

Type 2 mounting dimensions

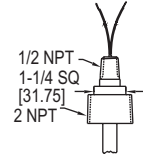

Type 3 mounting dimensions

The Series F7-MQ Quick-Ship Multi-Station Level Switch provides a customized level switch to meet application requirements. Switches can be configured with up to four different control points and stem lengths up to 72" (1.82 m). Stems and floats are available in 316 SS or brass, SPST or SPDT switches, and choice of mountings.

**FEATURES/BENEFITS**

- Customized level indication quickly and affordably
- Rugged construction with multiple options yielding exceptional versatility
- Capable of supporting larger, more buoyant floats
- Durable construction asserts long reliability in contaminated or turbulent media

**APPLICATIONS**

- Water level monitoring
- Oil level control
- Tank level control
- Diesel level monitoring

**SPECIFICATIONS**

**Service:** Compatible liquids.  
**Temperature Limits:** F1 and F2 with water: 0 to 180°F (-18 to 82°C); Oil: -40 to 230°F (-40 to 110°C); F3: -40 to 300°F (-40 to 149°C).  
**Electrical Connections:** 24" (61 cm) free leads; #22 AWG TFE and #18 AWG polymeric.  
**Mounting Orientation:** Vertical ±30°.

MODEL CHART																									
Example	F7-MQ	B	1	-4	F3	3	-07.00	-11.00	-15.00	-20.00	-24.00	J	F7-MQB1-4F33-07.00-11.00-15.00-20.00-24.00-J												
Construction	F7-MQ												Multi-station level, 1 to 4 switch points												
Stem & Connection Material		B											Brass with beryllium copper stops 316 SS with SS ARMCO PH-15-7MO stops												
Connection Type		S	1										1/2" NPT (float F2, F3 only) 1-1/4" NPT (float F1 only) 2" NPT (float F2, F3 only)												
Switch Points				#									Put 1 to 4 for the number of switch points desired												
Float Type					F1 F2 F3								<table border="1"> <thead> <tr> <th>Material</th> <th>Min. s.g.</th> <th>Max. Pressure</th> </tr> </thead> <tbody> <tr> <td>Buna-N</td> <td>0.75</td> <td>150 psi (10.3 bar)</td> </tr> <tr> <td>Buna-N</td> <td>0.55</td> <td>150 psi (10.3 bar)</td> </tr> <tr> <td>316 SS</td> <td>0.75</td> <td>750 psi (51.7 bar)</td> </tr> </tbody> </table>	Material	Min. s.g.	Max. Pressure	Buna-N	0.75	150 psi (10.3 bar)	Buna-N	0.55	150 psi (10.3 bar)	316 SS	0.75	750 psi (51.7 bar)
Material	Min. s.g.	Max. Pressure																							
Buna-N	0.75	150 psi (10.3 bar)																							
Buna-N	0.55	150 psi (10.3 bar)																							
316 SS	0.75	750 psi (51.7 bar)																							
Switch Type*					1 3								SPST, .17 A @ 120 VAC, .08 A @ 240 VAC, .13 A @ 120 VDC, .06 A @ 240 VDC SPDT, .17 A @ 120 VAC, .08 A @ 240 VAC, .13 A @ 120 VDC, .06 A @ 240 VDC												
Set Point Distance, L4†						00.00							In inches referenced from bottom of process connection												
Set Point Distance, L3†							00.00						In inches referenced from bottom of process connection												
Set Point Distance, L2†								00.00					In inches referenced from bottom of process connection												
Set Point Distance, L1†									00.00				In inches referenced from bottom of process connection												
Overall Length, L0										00.00			Min. length is L1+D; Max. length with connection length is 72" (1.82 m)												
Options												J	Junction box for wire leads, NEMA 4 (not available with connection type 1)												
*NO switch is standard. For NC place an "*" after the corresponding set point distance in the model number.																									
†No numbers needed beyond the number of switches specified.																									
<b>Note:</b> Models are built to your specifications																									



SERIES F7-MM | W.E. ANDERSON™ BY DWYER

# MINIATURE MULTI-STATION LEVEL SWITCH

Custom, Lightweight, Low Cost, 316 SS or Buna-N Floats

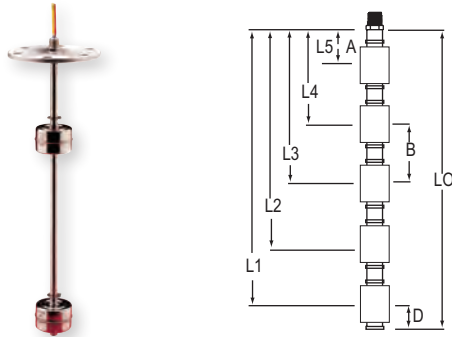

ACTUATION LEVELS			
Float Type	A	B	D
F1	7/8"	1-3/4"	3/4"
F2	3/4"	1-7/8"	1-1/16"
F3	3/4"	1-13/16"	15/16"
F4	13/16"	2-7/16"	1-7/16"
F5	9/16"	2-7/16"	1-3/4"
F6	15/16"	1-7/8"	7/8" (NO); 1-3/16" (NC)
F7	13/16"	2"	1-1/8"
F8	3/4"	1-7/8"	1-1/16"

Each switching point requires one float.  
 A=Minimum distance from actuation point to bottom of mounting  
 B=Minimum distance between actuation levels  
 D=Minimum distance from end of unit to lowest actuation point

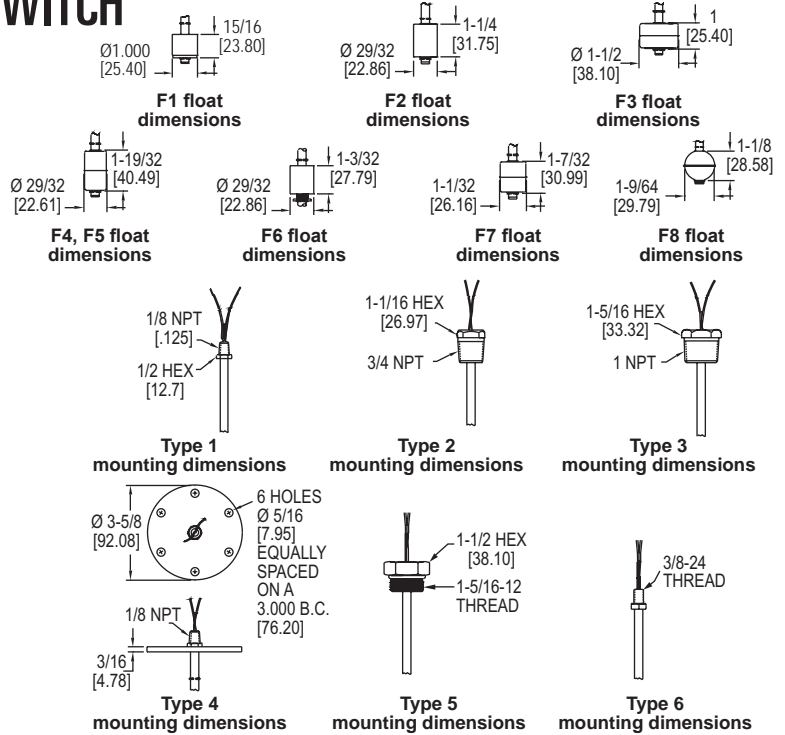

The Series F7-MM Miniature Multi-Station Level Switch provides a customized level switch to meet application requirements in a miniature size. Control up to five different level points across a maximum length of 48" (121 cm). Stems and mounting fixtures are available in 316 SS or brass.

**FEATURES/BENEFITS**

- Customized miniature level indication in a compact, lightweight design ideal for tanks less than 4' (1.2 m) deep
- Rugged construction with multiple options yielding exceptional versatility
- Miniature custom level switches are sturdy, compact and lightweight yet still rugged and durable

**APPLICATIONS**

- Water level monitoring
- Oil level control
- Tank level control
- Diesel level monitoring

MODEL CHART																																								
Example	F7-MM	B	1	-5	F1	1	-03.00	-07.00	-11.00	-15.00	-20.00	-25.00	F7-MMB1-5F11-03.00-07.00-11.00-15.00-20.00-25.00																											
<b>Construction</b>	F7-MM												Multi-station level, 1 to 5 switch points																											
<b>Stem &amp; Connection Material</b>		B											Brass with beryllium copper stops 316 SS with SS ARMCO PH-15-7MO stops																											
<b>Connection Type</b>			1										1/8" NPT 3/4" NPT (cannot be used with float F1, F3, F7 and F8) 1" NPT (cannot be used with float F3) 3-5/8" flange [maximum pressure is 50 psi (3.45 bar)] 1-5/16-12UNF-2A (cannot be used with float F3) 3/8-24																											
<b>Switch Points</b>													Put 1 to 5 for the number of switch points desired																											
<b>Float Type</b>						F1 F2 F3 F4 F5 F6 F7 F8							<table border="1"> <thead> <tr> <th>Material</th> <th>Min. s.g.</th> <th>Max. Pressure</th> </tr> </thead> <tbody> <tr> <td>Buna-N</td> <td>0.45</td> <td>300 psi (20.68 bar)</td> </tr> <tr> <td>Buna-N</td> <td>0.60</td> <td>250 psi (17.24 bar)</td> </tr> <tr> <td>316 SS</td> <td>0.70</td> <td>100 psi (6.89 bar)</td> </tr> <tr> <td>316 SS</td> <td>0.85</td> <td>150 psi (10.34 bar)</td> </tr> <tr> <td>316 SS</td> <td>1.10</td> <td>400 psi (27.58 bar)</td> </tr> <tr> <td>PTFE</td> <td>0.65</td> <td>1000 psi (68.95 bar)</td> </tr> <tr> <td>316 SS</td> <td>0.85</td> <td>275 psi (18.96 bar)</td> </tr> <tr> <td>316 SS</td> <td>0.90</td> <td>600 psi (41.37 bar)</td> </tr> </tbody> </table>	Material	Min. s.g.	Max. Pressure	Buna-N	0.45	300 psi (20.68 bar)	Buna-N	0.60	250 psi (17.24 bar)	316 SS	0.70	100 psi (6.89 bar)	316 SS	0.85	150 psi (10.34 bar)	316 SS	1.10	400 psi (27.58 bar)	PTFE	0.65	1000 psi (68.95 bar)	316 SS	0.85	275 psi (18.96 bar)	316 SS	0.90	600 psi (41.37 bar)
Material	Min. s.g.	Max. Pressure																																						
Buna-N	0.45	300 psi (20.68 bar)																																						
Buna-N	0.60	250 psi (17.24 bar)																																						
316 SS	0.70	100 psi (6.89 bar)																																						
316 SS	0.85	150 psi (10.34 bar)																																						
316 SS	1.10	400 psi (27.58 bar)																																						
PTFE	0.65	1000 psi (68.95 bar)																																						
316 SS	0.85	275 psi (18.96 bar)																																						
316 SS	0.90	600 psi (41.37 bar)																																						
<b>Switch Type*</b>						1							SPST, .17 A @ 120 VAC, .08 A @ 240 VAC, .13 A @ 120 VDC, .06 A @ 240 VDC SPST, .8 A @ 120 VAC, .4 A @ 240 VAC																											
<b>Set Point Distance, L5†</b>							00.00						In inches referenced from bottom of process connection																											
<b>Set Point Distance, L4†</b>								00.00					In inches referenced from bottom of process connection																											
<b>Set Point Distance, L3†</b>									00.00				In inches referenced from bottom of process connection																											
<b>Set Point Distance, L2†</b>										00.00			In inches referenced from bottom of process connection																											
<b>Set Point Distance, L1†</b>											00.00		In inches referenced from bottom of process connection																											
<b>Overall Length, L0</b>												00.00	Min. length is L1+D; Max. overall length is 48" (121 cm)																											

\*NO switch is standard. For NC place an "\*" after the corresponding set point distance in the model number.  
 †No numbers needed beyond the number of switches specified.  
**Note:** Models are built to your specifications

**SPECIFICATIONS**

**Service:** Compatible liquids.  
**Wetted Materials:** Stem, connection, and float.  
**Temperature Limits:** F1 and F2: Water, 180°F (82.2°C); Oil, -40 to 250°F (-40 to 121.1°C). All other floats: -40 to 300°F (-40 to 148.9°C).  
**Electrical Connection:** 24" (61 cm) free leads #22 AWG, TFE jacketed.  
**Mounting Orientation:** Vertical ±30°.

Level Switches, Float

USA: California Proposition 65

⚠WARNING: Cancer and Reproductive Harm - www.P65Warnings.ca.gov



# MULTI-STATION LEVEL SWITCH

Customize To Fit Application, Up to Six 316 SS or Buna-N Floats

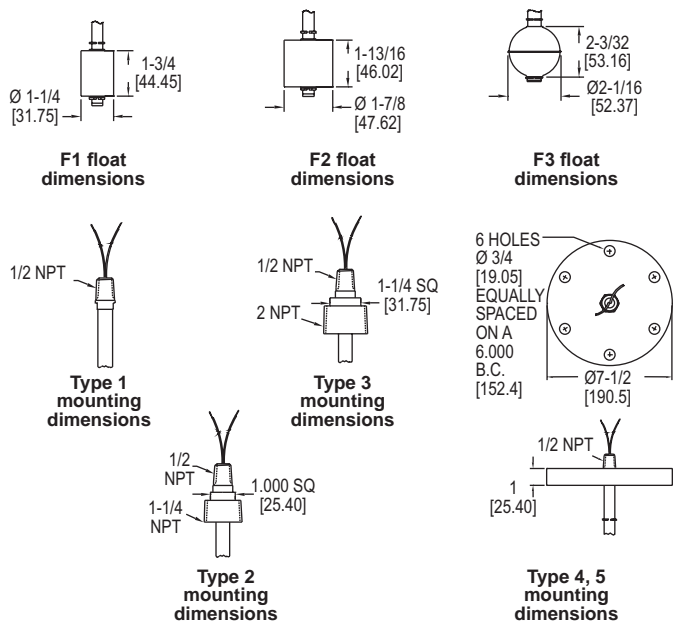
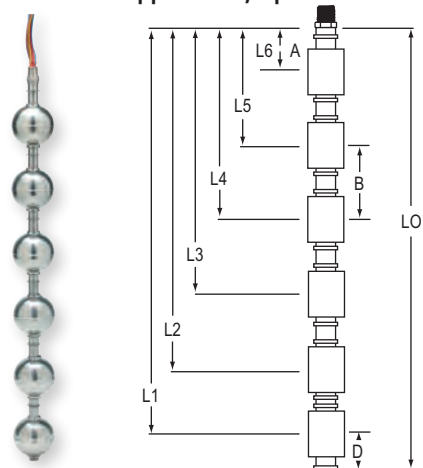

ACTUATION LEVELS		
A	B	D
1-1/2" (38.10 mm)	3" (76.20 mm)	2" (50.80 mm)
Each switching point requires one float.		
A=Minimum distance from actuation point to bottom of mounting		
B=Minimum distance between actuation levels		
D=Minimum distance from end of unit to lowest actuation point		

The **Series F7-MS Multi-Station Level Switch** provides a customized level switch to meet application requirements. Switches can be configured with up to six different control points and stem lengths up to 140" (3.56 m). Stems and floats are available in 316 SS or brass, SPST or SPDT switches, and choice of mountings.

**FEATURES/BENEFITS**

- Customized level indication quickly and affordably
- Rugged construction with multiple options yielding exceptional versatility
- Capable of supporting larger, more buoyant floats
- Durable construction asserts long reliability in contaminated or turbulent media

**APPLICATIONS**

- Water level monitoring
- Oil level control
- Tank level control
- Diesel level monitoring

**MODEL CHART**

Example	F7-MS	B	1	-5	F3	1	-04.00	-07.00	-11.00	-15.00	-20.00		-24.00	J	F7-MSB1-5F31-04.00-07.00-11.00-15.00-20.00-24.00-J												
<b>Construction</b>	F7-MS	B													Multi-station level, 1 to 6 switch points												
<b>Stem &amp; Connection Material</b>		B													Brass with beryllium copper stops 316 SS with SS ARMCO PH-15-7MO stops												
<b>Connection Type</b>		S	1												1/2" NPT (float F2, F3 only) 1-1/4" NPT (float F1 only) 2" NPT 3" 150# flange carbon steel (conn. material S only, float F2, F3 only) Max. pressure: 150 psi (10.3 bar) 3" 150# flange 316 SS (conn. material S only, float F2, F3 only) Max. pressure: 150 psi (10.3 bar)												
<b>Switch Points</b>															Put 1 to 6 for the number of switch points desired												
<b>Float Type</b>					F1										<table border="1"> <thead> <tr> <th>Material</th> <th>Min. s.g.</th> <th>Max. Pressure</th> </tr> </thead> <tbody> <tr> <td>Buna-N</td> <td>0.75</td> <td>150 psi (10.3 bar)</td> </tr> <tr> <td>Buna-N</td> <td>0.55</td> <td>150 psi (10.3 bar)</td> </tr> <tr> <td>316 SS</td> <td>0.75</td> <td>750 psi (51.7 bar); Units &gt;72": 300 psi (20.7 bar)</td> </tr> </tbody> </table>	Material	Min. s.g.	Max. Pressure	Buna-N	0.75	150 psi (10.3 bar)	Buna-N	0.55	150 psi (10.3 bar)	316 SS	0.75	750 psi (51.7 bar); Units >72": 300 psi (20.7 bar)
Material	Min. s.g.	Max. Pressure																									
Buna-N	0.75	150 psi (10.3 bar)																									
Buna-N	0.55	150 psi (10.3 bar)																									
316 SS	0.75	750 psi (51.7 bar); Units >72": 300 psi (20.7 bar)																									
<b>Switch Type*</b>					1										SPST, .17 A @ 120 VAC, .08 A @ 240 VAC, .13 A @ 120 VDC, .06 A @ 240 VDC SPST, .8 A @ 120 VAC, .4 A @ 240 VAC SPDT, .17 A @ 120 VAC, .08 A @ 240 VAC, .13 A @ 120 VDC, .06 A @ 240 VDC												
<b>Set Point Distance, L6†</b>						00.00									In inches referenced from bottom of process connection												
<b>Set Point Distance, L5†</b>							00.00								In inches referenced from bottom of process connection												
<b>Set Point Distance, L4†</b>								00.00							In inches referenced from bottom of process connection												
<b>Set Point Distance, L3†</b>									00.00						In inches referenced from bottom of process connection												
<b>Set Point Distance, L2†</b>										00.00					In inches referenced from bottom of process connection												
<b>Set Point Distance, L1†</b>											00.00				In inches referenced from bottom of process connection												
<b>Overall Length, L0</b>												00.00			Min. length is L1+D; Max. length with connection type 1: 36" (91.4 cm), type 2: 60" (152.4 cm) and types 3, 4, 5: 140" (355.6 cm)												
<b>Options</b>													J		Junction box for wire leads, NEMA 4 (not available with connection type 1)												

\*NO switch is standard. For NC place an "N" after the corresponding set point distance in the model number.

†No numbers needed beyond the number of switches specified.

Note: Models are built to your specifications

**SPECIFICATIONS**

**Service:** Compatible liquids.  
**Wetted Materials:** Stem, connection, and float.  
**Temperature Limits:** Buna-N floats: 180°F (82.2°C) in water, -40 to 230°F (-40 to 110°C) in oil; SS floats: -40 to 300°F (-40 to 148.9°C).  
**Wire Leads:** 24" (61 cm) free leads; #22 AWG, TFE jacketed, and #18 AWG polymeric.  
**Mounting Orientation:** Vertical ±30°.



SERIES 123 & 125 | MERCROID® BY DWYER



# BOILER WATER LEVEL CONTROL

Heavy Duty, Cast Iron Chamber

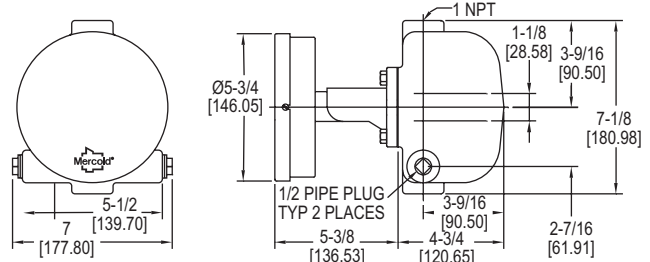

The Series 123 & 125 Boiler Water Level Control is designed for boiler applications, the Model 123 is primarily used for low water cut-off or feed-water control. The 125 offers the same long lasting service with a direct action mercury switch movement that provides a close deadband where needed.

**FEATURES/BENEFITS**

- Special snap action switch mechanism options eliminates frequent operation due to surging water level
- Transparent cover provides convenient visible operation of the switch
- Flanged chamber for easy clean out and replacement of float or switch mechanism without removing the unit from piping

**APPLICATIONS**

- Boiler low water cut-off
- Boiler feed-water control
- Condensate tanks
- Deaerators

MODEL CHART	
Model	Switch Type
123-153	SPDT mercury
123-7000-153	SPDT snap

**SPECIFICATIONS**

**Service:** Compatible liquids. Cast iron is not for use with lethal or flammable substances either liquid or gaseous.  
**Wetted Materials:** Body: Cast iron; Float: 304 SS; Trim and packing gland: Brass; Packing: Carbon; Body gasket: Carbon.  
**Temperature Limit:** Ambient Temperature: 212°F (100°C); Process Temperature: 365°F (185°C).  
**Pressure Limit:** 150 psig (10.34 bar).  
**Enclosure Rating:** General purpose. Optional weatherproof.  
**Switch Type:** SPDT snap switch or mercury switch. Optional DPDT or two stage.

**Electrical Rating:** Snap switch: 12 A @ 120 VAC, 5 A @ 240 VAC, 0.5 A @ 125 VDC resistive, 0.25 A @ 250 VDC resistive; Mercury switch: 4 A @ 120 VAC/DC, 2 A @ 240 VAC/DC.  
**Electrical Connections:** Screw terminal. Conduit Connection: 7/8" (22.23 mm) hole for 1/2" (12.7 mm) conduit.  
**Process Connections:** 1" female NPT.  
**Mounting Orientation:** Vertical.  
**Deadband:** Approximately 1-1/2" (38.1 mm).  
**Specific Gravity:** 0.88 min.  
**Options:** Manual reset.  
**Weight:** 20 lb (9.1 kg).  
**Agency Approvals:** CSA, UL. (Snap switch is not rated).

SERIES 102 & 1102 | MERCROID® BY DWYER



# FLANGED CHAMBER TYPE LEVEL CONTROL

Operating Pressures to 300 PSIG

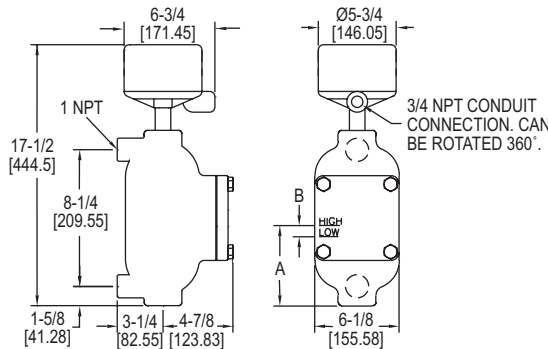

Specific Gravity	A	B
1.0	5-1/16 [129 mm]	3/4 [19 mm]
0.6	5-13/16 [148 mm]	1 [25.4 mm]

The Series 102 & 1102 Flanged Chamber Type Level Control is external cage type level switches which are self-contained in a side mount body. The 102 series will operate to a minimum specific gravity of 0.60 and the 1102 series will operate to a specific gravity of 0.40. These series contain a stainless steel float and offer a choice of cast iron, cast steel, or cast 316 SS float chamber.

**FEATURES/BENEFITS**

- Unique design allows the simple removal of four bolts from the inspection plate to examine the float and chamber for cleaning or wear without disconnecting the piping or electrical circuitry
- Electrical enclosures provide general purpose, weatherproof, explosion-proof or explosion-proof/vapor proof capability as well as cost effective cast 316 SS float chamber option
- Electrical circuits using hermetically sealed snap action or mercury contacts are available in a variety of actions including SPST, SPDT, DPDT and DPST combinations
- The 102 design features three 1" NPT process connections for side/side or side/bottom piping allowing the bottom 1" NPT connection to be used as a drain when using the side/side process connection

**APPLICATIONS**

- Pressure or vacuum vessels
- Chemical processing plants
- Steam and electric generating stations
- Hydraulic accumulators
- Vapor-liquid separators
- Scrubbers
- Oil refineries
- Storage tanks

**SPECIFICATIONS**

**Service:** Compatible liquids. Cast iron is not for use with lethal or flammable substances either liquid or gaseous.  
**Wetted Materials:** Body: Cast iron. Optional cast steel or 316 SS; Float and trim: 303 SS, 304 SS, 316 SS, and 430 SS. Option of all 316 SS; Body gasket: Carbon.  
**Temperature Limit:** Ambient Temperature: 212°F (100°C); Process Temperature: 425°F (218°C).  
**Pressure Limit:** 300 psig (20.7 bar). Optional rating to 400 psig (27.6 bar).  
**Enclosure Rating:** NEMA 4X (IP66). Optional general purpose or explosion-proof.  
**Repeatability:** ±1/4" (6.4 mm).  
**Switch Type:** SPDT snap switch, hermetically sealed snap switch, or mercury switch. Optional DPDT or two stage.

**Electrical Rating:** Snap switch: 12 A @ 120 VAC, 5 A @ 240 VAC, 0.5 A @ 125 VDC resistive, 0.25 A @ 250 VDC resistive; Hermetically sealed snap switch: 5 A @ 125 VAC, 5 A @ 240 VAC, 5 A @ 30 VDC resistive; Mercury switch: 4 A @ 120 VAC/DC, 2 A @ 240 VAC/DC. Higher contact ratings available for the mercury switch.  
**Electrical Connections:** Screw terminal.  
**Conduit Connection:** 3/4" female NPT.  
**Process Connections:** 1" female NPT.  
**Mounting Orientation:** Vertical.  
**Set Point Adjustment:** ±1" (25.4 mm).  
**Specific Gravity:** 0.6 min.  
**Weight:** 35 lb (15.9 kg).  
**Agency Approvals:** UL.

MODEL CHART	
Model	Switch Type
102-WT-4810-C-60	SPDT mercury
102-WT-7810-C-60	SPDT snap
102-WT-7810HM-C-60	SPDT hermetically sealed snap

USA: California Proposition 65  
 ⚠️WARNING: Cancer and Reproductive Harm - www.P65Warnings.ca.gov



SERIES CFS2 | MERCOID® BY DWYER



# CABLE FLOAT SWITCH

Mercury-Free, UL/CSA Approved Options

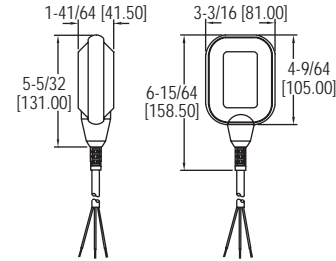

The Series CFS2 Cable Float Switch is a mechanically actuated floating switch intended to activate electrical components, such as pumps, to start and stop automatically. Optional cables are available. Contact factory for cable length options ranging from 10 to 70' (3 to 21 m).

### FEATURES/BENEFITS

- High reliability with mercury-free, magnetic, mechanical internal design
- Economical pricing with multiple option available for increased versatility
- Easy installation with counterweights and cable hangers to suit a variety of mounting applications

### APPLICATIONS

- Water level monitoring
- Tank level control
- High or low level alarm
- Municipal water control
- Industrial water control
- Filling or draining reservoirs and tanks
- Pump automation

### SPECIFICATIONS

**Service:** Compatible liquids.  
**Wetted Materials:** Enclosure: Polypropylene; Cable: See model chart.  
**Temperature Limits:** 32 to 122°F (0 to 50°C).  
**Pressure Limits:** 14.5 psi (1 bar).  
**Enclosure Rating:** IP68.  
**Switch Type:** See model chart.  
**Electrical Rating:** CFS2-XXBXX-XX: 10 (8) A @ 250 VAC; CFS2-XXDXX-XX: 1 HP @ 125 VAC 16 FLA; 2 HP @ 250 VAC 12 FLA.  
**Shipping Weight:** Enclosure: 5.43 oz (154 g); Cable: 0.77 oz (21.27 g) per ft.  
**Agency Approvals:** See model chart.

### ACCESSORIES

Model	Description
A-457	7.76 oz (220 g) counterweight
A-459	Cable hanger

### MODEL CHART

Model	Cable Type	Approvals	Switch Type	Cable Length	Model	Cable Type	Approvals	Switch Type	Cable Length
CFS2-ONBPN-20	PVC	CE	SPST NO	20' (6.10 m)	CFS2-DNBPN-40	PVC	CE	SPDT	40' (12.19 m)
CFS2-ONBPN-30	PVC	CE	SPST NO	30' (9.14 m)	CFS2-DNBPN-50	PVC	CE	SPDT	50' (15.24 m)
CFS2-ONBPN-40	PVC	CE	SPST NO	40' (12.19 m)	CFS2-DNBPN-60	PVC	CE	SPDT	60' (19.29 m)
CFS2-ONBPN-50	PVC	CE	SPST NO	50' (15.24 m)	CFS2-DNBPN-80	PVC	CE	SPDT	80' (24.38 m)
CFS2-CNBPN-20	PVC	CE	SPST NC	20' (6.10 m)	CFS2-DNBPN-100	PVC	CE	SPDT	100' (30.48 m)
CFS2-CNBPN-30	PVC	CE	SPST NC	30' (9.14 m)	CFS2-OGDSN-20	SJOW	UL/CSA	SPST NO	20' (6.10 m)
CFS2-CNBPN-40	PVC	CE	SPST NC	40' (12.19 m)	CFS2-OGDSN-30	SJOW	UL/CSA	SPST NO	30' (9.14 m)
CFS2-CNBPN-50	PVC	CE	SPST NC	50' (15.24 m)	CFS2-OGDSN-40	SJOW	UL/CSA	SPST NO	40' (12.19 m)
CFS2-DNBPN-7	PVC	CE	SPDT	7' (2.13 m)	CFS2-OGDSN-50	SJOW	UL/CSA	SPST NO	50' (15.24 m)
CFS2-DNBPN-10	PVC	CE	SPDT	10' (3.05 m)	CFS2-CGDSN-20	SJOW	UL/CSA	SPST NC	20' (6.10 m)
CFS2-DNBPN-15	PVC	CE	SPDT	15' (4.57 m)	CFS2-CGDSN-30	SJOW	UL/CSA	SPST NC	30' (9.14 m)
CFS2-DNBPN-20	PVC	CE	SPDT	20' (6.10 m)	CFS2-CGDSN-40	SJOW	UL/CSA	SPST NC	40' (12.19 m)
CFS2-DNBPN-30	PVC	CE	SPDT	30' (9.14 m)	CFS2-CGDSN-50	SJOW	UL/CSA	SPST NC	50' (15.24 m)

SERIES FSW2 | MERCOID® BY DWYER

# FREE-FLOATING LEVEL SWITCH

Designed for Industrial Applications, Mercury-Free, Self Counter-Weighted

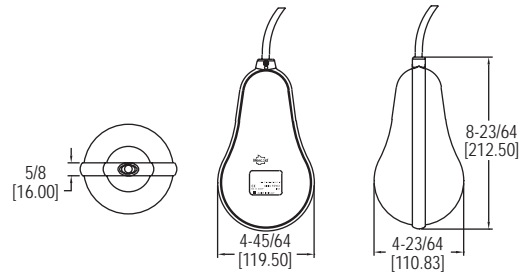

The Series FSW2 Free-Floating Level Switch is a self-counterweighted, mechanically actuated floating switch intended to activate electrical components, such as pumps, to start and stop automatically. Optional cables are available. Contact factory for cable length options ranging from 10 to 70' (3 to 21 m).

### FEATURES/BENEFITS

- Body is free of any irregularities allowing substances to effortlessly glide off and consists of a double airtight chamber with high-pressure melted polypropylene re-injection sealing to ensure a perfect seal reducing maintenance events
- High reliability with mercury-free, magnetic, mechanical internal design
- Economical pricing with multiple option available for increased versatility
- Seamless installation with self-counterweighted body and cable hangers to suit a variety of mounting applications

### APPLICATIONS

- Wastewater level monitoring
- Tank level control
- High or low level alarm
- Municipal wastewater control
- Industrial wastewater control

### ACCESSORIES

Model	Description
A-459	Cable hanger

### SPECIFICATIONS

**Service:** Compatible liquids, slurries.  
**Wetted Materials:** Enclosure: Polypropylene; Cable: PVC.  
**Operating Temperature:** 32 to 122°F (0 to 50°C).  
**Pressure Limits:** 29 psi (2 bar).  
**Enclosure Rating:** IP68.  
**Switch Type:** See model chart.  
**Electrical Rating:** 10 (3) A @ 250 VAC.  
**Mounting Orientation:** Vertical.  
**Shipping Weight:** Enclosure: 2.4 lb (1100 g); Cable: 0.77 oz (21.27 g) per ft.  
**Agency Approvals:** CE.

### MODEL CHART

Model	Switch Type	Cable Length ft (m)	Model	Switch Type	Cable Length ft (m)
FSW2-ONPN-20	SPST NO	20 (6.10)	FSW2-DNPN-10	SPDT	10 (3.05)
FSW2-ONPN-30	SPST NO	30 (9.14)	FSW2-DNPN-15	SPDT	15 (4.57)
FSW2-ONPN-40	SPST NO	40 (12.19)	FSW2-DNPN-20	SPDT	20 (6.10)
FSW2-ONPN-50	SPST NO	50 (15.24)	FSW2-DNPN-30	SPDT	30 (9.14)
FSW2-CNPN-20	SPST NC	20 (6.10)	FSW2-DNPN-40	SPDT	40 (12.19)
FSW2-CNPN-30	SPST NC	30 (9.14)	FSW2-DNPN-50	SPDT	50 (15.24)
FSW2-CNPN-40	SPST NC	40 (12.19)	FSW2-DNPN-60	SPDT	60 (18.29)
FSW2-CNPN-50	SPST NC	50 (15.24)	FSW2-DNPN-80	SPDT	80 (24.38)
			FSW2-DNPN-100	SPDT	100 (30.48)





SERIES OLS | W.E. ANDERSON™ BY DWYER

# OPTITROL® OPTICAL LEVEL SWITCHES

Low Cost, Compact, LED Indication, No Moving Parts

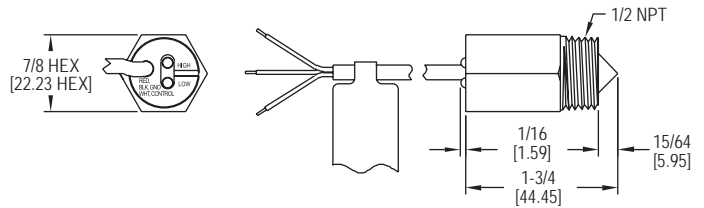

The Series OLS Optitrol® Optical Level Switches are low cost, rugged optical level switches that indicate the presence or absence of liquid via infrared light that is reflected back through the prism lens. This series offers three optional materials, 316 SS, polysulfone and PFA.

**FEATURES/BENEFITS**

- Provides rapid response while employing no moving parts for stable process control
- Bright red and green LED's indicate the presence or absence of liquid for true, local indication
- Three optional materials, 316 SS, polysulfone and PFA provide application flexibility
- Compact switch can be quickly mounted horizontally or vertically for each installation

**APPLICATIONS**

- Food and beverage systems
- Liquid holding tanks
- Hydraulic reservoirs
- Pharmaceutical systems
- Air conditioning systems
- Sumps

**SPECIFICATIONS**

**Service:** Noncoating compatible liquids.  
**Wetted Materials:** See model chart.  
**Temperature Limit:** Process: OLS-10, 11: 200°F (93.3°C), OLS-12: 120°F (48.9°C); Ambient: OLS-10, 11: 175°F (79.4°C), OLS-12: 120°F (48.9°C).  
**Pressure Limit:** OLS-11, 12: 200 psig (13.8 bar); OLS-10: 1000 psig (69 bar).  
**Repeatability:** ±0.02" (0.5 mm).  
**Switch Type:** NPN open collector.  
**Power Requirements:** 10 to 28 VDC.

**Output Signal:** Vout (max) = 28 VDC, Isink (max) = 100 mA.  
**Current Consumption:** 35 mA max.  
**Electrical Connections:** 38" (965.2 mm) 3 conductor cable, 22 AWG wire.  
**Process Connection:** 1/2" male NPT.  
**Mounting Orientation:** Can be mounted in any position.  
**Specific Gravity:** No min.  
**Weight:** 3 oz (0.085 kg).

**MODEL CHART**

Model	Wetted Materials
OLS-10	316 SS/polysulfone
OLS-11	Polysulfone
OLS-12	PFA

SERIES B-190 | MERCROID® BY DWYER

# LIQUID LEVEL SWITCH-CONTROL

Top Mounted Displacer Type, Adjustable Setpoints, Magnetic Operation, Optional Hermetically Sealed Snap Switch

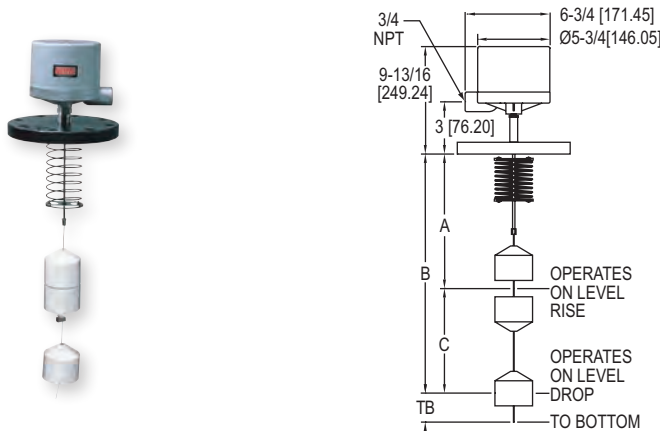

**DIMENSIONS FOR 1.0 S.G. @ 100°F (38°C)**

A		C		TB	B
Max.	Min.	Max.	Min.	Max.	Min.
116-1/2" (2.66 m)	6-1/2" (165 mm)	114" (2.9 m)	6-3/4" (172 mm)	2-1/2" (64 mm)	122-1/4" (3.1 m)

The Series B-190 Liquid Level Switch-Control is a top mount displacer type level control. They work on the principle that submerged solids weigh less in liquids, and as the liquid level rises and their weight decreases, the tension on the spring by which they are suspended is decreased. This Series is offered in a range of cable lengths, specific gravities, circuit types and enclosure ratings.

**FEATURES/BENEFITS**

- Extremely versatile design
- Displacers are suspended on a coil spring and do not float on the surface of liquids and are unaffected by turbulence or pressure
- Excellent for applications with viscous or dirty liquids

**APPLICATIONS**

- Pumping stations
- Foaming liquids
- Sanitary/sewage treatment
- Paints & varnishes
- Agitated or turbulent fluids
- Heavy oil refineries
- Chemical plants
- Power generating stations
- Viscous or dirty liquids

**MODEL CHART**

Model	Switch Type
B190-WT-4810-P-A-1.0-6	SPDT mercury
B190-WT-7810-P-A-1.0-6	SPDT snap
B190-WT-7810HM-P-A-1.0-6	SPDT hermetically sealed snap

**SPECIFICATIONS**

**Service:** Compatible liquids.  
**Wetted Materials:** Cable, spring and stops: 316 SS; Optional Inconel® spring; Displacers: Porcelain; Optional 304 SS, 316 SS, or carbon graphite.  
**Temperature Limits:** Ambient Temperature: 32 to 200°F (0 to 93°C); Process Temperature: 32 to 200°F (0 to 93°C).  
**Pressure Limit:** 125 psig (8.6 bar). Higher ratings available.  
**Enclosure Rating:** NEMA 4X. Optional general purpose or explosion-proof.  
**Switch Type:** SPDT snap switch, hermetically sealed snap switch, or mercury switch. Optional DPDT or two stage.  
**Electrical Rating:** Snap switch: 12 A @ 120 VAC, 5 A @ 240 VAC, 0.5 A @ 125 VDC resistive, 0.25 A @ 250 VDC resistive; Hermetically sealed snap switch: 5 A @ 120 VAC, 5 A @ 240 VAC, 5 A @ 30 VDC resistive; Mercury switch: 4 A @ 120 VAC/DC, 2 A @ 240 VAC/DC. Higher contact ratings available for the mercury switch.

**Electrical Connections:** Screw terminal.  
**Conduit Connection:** 3/4" female NPT.  
**Process Connections:** 4" 125 cast iron flange. Other material, size, and rating flanges are available.  
**Mounting Orientation:** Vertical.  
**Set Point Adjustment:** Adjustable by moving displacers see dimension chart for minimum and maximum values.  
**Deadband:** Adjustable by moving displacers see dimension chart for minimum and maximum values.  
**Specific Gravity:** Standard is 1.0. Specify when ordering by replacing 1.0 in model number with specific gravity setting desired. Settable range is 0.5 to 1.2.  
**Cable Length:** 10' (3 m) standard. Optional up to 100' (30.5 m).  
**Weight:** 25 lb (11.34 kg).  
**Agency Approvals:** UL (None on HM switch).

Inconel® is a registered trademark of Huntington Alloys Corporation





# CAPACITIVE LEVEL SWITCH

Powder, Bulk, or Liquids, Auto-Calibration

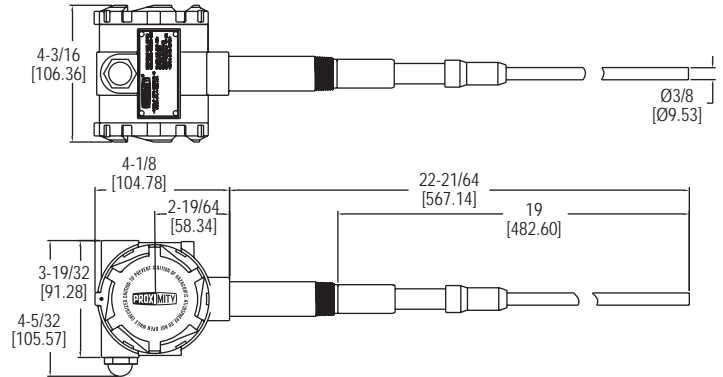

The **Series CLS2 Capacitive Level Switch** is a capacitive technology level switch which can be used for liquids, powders and bulk materials. It is offered with PVDF and 316 SS wetted material, weatherproof enclosure, DPDT output and a variety of process connections.

**FEATURES/BENEFITS**

- No moving parts permitting for no jams, no wear, nothing to break, and no maintenance
- Impulse RF admittance measurement combined with an active guard, provides excellent level measurement and stability while being insensitive to material buildup
- Immune to external RF sources like walkie-talkies and cell phones as well as minimal interference with radio communication or other electronic systems
- Automatic calibration with no need to turn calibration pots, just push the calibration button and an external magnet to activate the calibration without having to open the enclosure saving time
- Coat guard probe is not affected by sticky, dusty, or clingy materials that coat or build preventing false alarms
- Status indication via an ultra-high brightness external red LED switch status indicator, and internal indicators for power, sensor, and switch status that can be seen externally with window cap option (external LED on weatherproof model only)
- Can be used for liquid interface applications to detect the level of two immiscible liquids that have different dielectric constants such as oil and water
- Failsafe setting with output switches that can be set for NO or NC condition on loss of power
- Time delay prevents false alarms from material splashing, agitation, etc.
- Removable terminal block snaps in and out enabling easy wiring outside of the enclosure
- Universal power supply with one model that works from 12-240 VAC/DC without any jumpers or change of setting
- Wetted materials of PVDF and 316 SS assure great chemical compatibility and meet food grade requirements

**APPLICATIONS**

- Sewage and wastewater
- Food and beverage
- Pharmaceuticals
- Sumps
- Level monitoring in receivers
- Boilers and steam generators
- Caustics and acids
- Reservoirs
- Level indication in silos
- Transporters in pneumatic conveying systems

MODEL CHART										
Example	CLS2	-W	1	1	R	K	1	-019	-M20	CLS2-W11RK1-019-M20
Series	CLS2									Capacitive level switch
Enclosure		W								Weatherproof
Switch			1							DPDT rated 8 A @ 12/240 VAC, 30 VDC res.
Power Supply				1						12-240 VAC/DC
Probe Type					R	T	C			Standard rod: 316 SS, .375" diameter Threaded rod: 316 SS (can attach 47" (1.2 m) field extensions.*) Cable: 316 SS with weight
Insulator Material							K			PVDF
Process Connection						1				3/4" male NPT
						2				1" male NPT
						3				1-1/2" male NPT
						4				3/4" BSPT
						5				1" BSPT
						6				1-1/2" BSPT
						8				1-1/2" sanitary clamp
						9				2" sanitary clamp
Probe Length								XXX		Insertion length in inches. Example 019 is 19" length. (Minimum length is 6", with 3/4" sensing tip)
Options									M20	M20 conduit connection with cable gland
									WC	Window cap

Example: CLS2-W11RK1-019.  
\*Extension rods sold separately.

**SPECIFICATIONS**

**Service:** Liquids, powder, and bulk materials compatible with wetted materials.  
**Wetted Materials:** 316 SS and polyvinylidene fluoride (PVDF).  
**Temperature Limits:** Ambient: -40 to 185°F (-40 to 85°C), -4 to 185°F (-20 to 85°C) with under 24 VAC/DC power supply; Process: -40 to 250°F (-40 to 121°C).  
**Pressure Limit:** 365 psi (25 bar).  
**Enclosure Rating:** Weatherproof, NEMA 4X (IP66).  
**Switch Type:** DPDT (two form C).  
**Electrical Rating:** 8 A @ 120/240 VAC res., 30 VDC. 1/2 hp @ 120 VAC and 1/4 hp @ 240 VAC ind.  
**Power Requirements:** 12-240 VAC/DC.  
**Power Consumption:** 2.8 watts max.  
**Electrical Connection:** 1/2" NPT conduit opening, screw termination with removable terminal block.  
**Process Connection:** See model chart.  
**Mounting Orientation:** Vertical or horizontal.  
**Set Point Adjustment:** Trips when product touches probe. Cut or extend probe to length of desired trip point. Can be cut as short as 1" and can be extended by welding on to probe. (Minimum length will be effected by material being sensed.)  
**Response Time:** 0.2 s.  
**Time Delay:** Adjustable, 0 to 60 s.  
**Spark/Static Protection:** 10 M Ω dissipation resistance with spark gap. Surge current to 100A max.  
**Sensitivity:** 8 selectable settings, 1, 2, 4, 6, 8, 10, 14, 20 pF (at 30 pF nominal free capacitance).  
**Agency Approvals:** CE, cULus.

**Dwyer****MODEL CLS1****CAPACITANCE LEVEL SWITCH**

For Solids, Liquids or Slurries, Fail-Safe Protection, &lt;1 pF Sensitivity

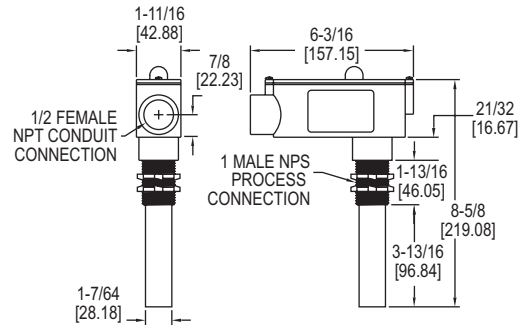

The **Model CLS1 Capacitance Level Switch** provides reliable point level measurement of solids, liquids and slurries in metallic or non-metallic tanks and vessels. It detects the presence or absence of material in contact with the probe by sensing a change in the capacitance.

**FEATURES/BENEFITS**

- Electronics provide highly sensitive measurement detection (requires less than a 1 picofarad shift from ambient)
- State of the art technology ignores material build-up on the vessel sidewall or along the probe assembly
- One time calibration is simple with a single multi-turn potentiometer
- Red LED on housing indicates sensor status
- Adjustable 1-30 second time delay and a 5 A, SPDT fail-safe relay output
- Added installation flexibility with vertically or horizontally mounting

**APPLICATIONS**

- High or low level detection
- Bins
- Silos
- Tanks
- Hoppers
- Chutes

**SPECIFICATIONS**

**Service:** Solids, liquids, or slurries.  
**Wetted Material:** CPVC.  
**Temperature Limits:** Process: -40 to 240°F (-40 to 116°C); Ambient: -40 to 185°F (-40 to 85°C).  
**Enclosure Rating:** NEMA 4X (IP66), PVC, dust tight, water resistant.  
**Switch Type:** SPDT.  
**Electrical Rating:** 5 A @ 250 VAC.  
**Power Requirements:** 120 VAC, 1.5 VA.  
**Conduit Connection:** 3/4" female NPT.  
**Process Connection:** 1" male NPS.  
**Mounting Orientation:** Vertical or horizontal.  
**Sensitivity:** Adjustable to < 1 pF.  
**Fail-Safe:** Switch selectable, high/low.  
**Time Delay:** Adjustable 1 to 30 s.  
**Weight:** 2.0 lb (0.91 kg).

**MODEL CHART**

Model	Description
CLS1	Capacitance level switch

**MODEL VRLS | PROXIMITY® BY DWYER****VIBRATING ROD LEVEL SWITCH**

Economical, No Material Build Up, For Powder or Bulk Solids

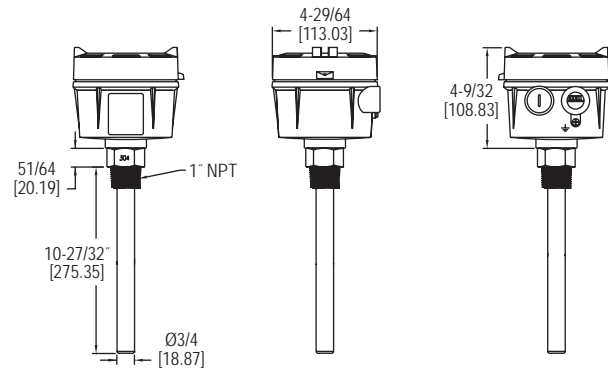

The **Model VRLS Vibrating Rod Level Switch** is economical choice in level detection of powders and bulk solids. The VRLS incorporates a piezoelectric crystal that vibrates the rod at its natural frequency, when contact material is present it dampens the vibrations and the switch changes state.

**FEATURES/BENEFITS**

- Probe design allows for self-cleaning, ensuring no build-up or bridging of material and accurate detection
- No mechanical moving parts with no routine maintenance required
- Sensitivity is adjustable for detection ranging from large granular material to small powders with low bulk densities.
- The failsafe mode can be set for failure on high level or failure on low level using a selector switch in the enclosure
- Unaffected by the dielectric constant of the sensed material, making it superior to a capacitance level switch for applications where the dielectric constant is too low, where there is more than one material being used in one vessel, and when material moisture content can change
- Ideal for applications where the bulk density is too low for a rotating paddle level switch

**APPLICATIONS**

- Pulp and paper processing
- Mining
- Food and beverage
- Silos
- Hoppers

**SPECIFICATIONS**

**Service:** Dry powder or bulk materials compatible with wetted materials.  
**Sensitivity:** Min. bulk density of 20 lb/ft<sup>3</sup> (320 kg/m<sup>3</sup>).  
**Wetted Materials:** 304 SS.  
**Temperature Limits:** Ambient: -40 to 140°F (-40 to 60°C); Process: -40 to 176°F (-40 to 80°C).  
**Pressure Limit:** 150 psi (10 bar).  
**Power Requirement:** 20-250 VAC/VDC, 50/60 Hz.  
**Power Consumption:** 15 VA.  
**Enclosure:** Aluminum, painted.  
**Enclosure Rating:** IP65.  
**Switch Type:** SPDT.  
**Electrical Rating:** 5 A @ 250 VAC.  
**Electrical Connections:** Screw terminals.  
**Conduit Connection:** 1/2" female NPT x 2.  
**Process Connection:** 1" male NPT.  
**Indication Lights:** Internal: green and red LED.  
**Sensing Delay:** 0 to 6 s.  
**Weight:** 4.4 lb (2.0 kg).

**MODEL CHART**

Model	Description
VRLS-01	Vibrating rod level switch



# TUNING FORK LEVEL SWITCH

Perfect for Sensing Low Bulk Density or Low Dielectric Materials

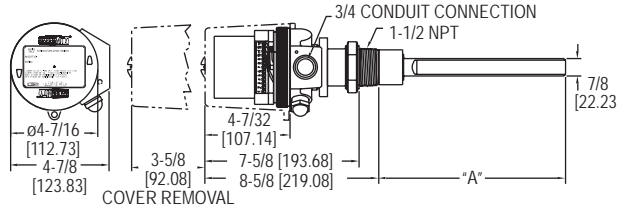
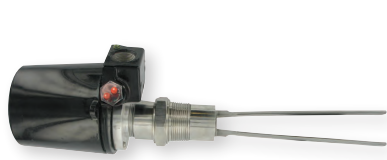

Extension Length	DIM "A"
None	9-1/4 (234.95)
6 in	15-7/8 (403.23)
12 in	21-7/8 (555.63)
18 in	27-7/8 (708.03)
24 in	33-7/8 (860.43)
36 in	45-7/8 (1165.23)
48 in	57-7/8 (1470.03)

The **Series TFLS Tuning Fork Level Switch** is ideal for level control of powders and fine grained solids, especially those with a low bulk density. The TFLS incorporates a piezoelectric crystal that vibrates the fork at its natural frequency, when contact material is present it dampens the vibrations and the switch changes state.

**FEATURES/BENEFITS**

- Status indication with external LED switch indicator, and internal indicators for normal and alarm status
- No calibration required for quick and easy installation
- No mechanical moving parts with no routine maintenance required
- Unaffected by the dielectric constant of the sensed material, making it superior to a capacitance level switch for applications where the dielectric constant is too low, where there is more than one material being used in one vessel, and when material moisture content can change
- Vibrating fork design is ideal for low bulk density and low dielectric constant products, detecting products down to 1.8 lb/ft<sup>3</sup> (30 g/l)
- Ideal for applications where the bulk density is too low for a rotating paddle level switch
- Adjustable sensitivity can be set to ignore lighter bulk density products and only detect heavier products, such as sand, gravel, or polyester chips in water
- Unit is not affected by vibration from conveying systems, motors, or the movement of material
- Mounted in any position and is available with factory built extensions for mounting on the top of the storage vessel
- Failsafe setting with output switch that can be set for NO or NC condition on loss of power
- Time delay prevents false alarms from material surges
- Universal power supply yields one model which works with 90-265 VAC and 24 VDC

**APPLICATIONS**

- Chemical processing
- Pulp and paper processing
- Mining
- Food and beverage
- Lime, styrofoam, tobacco, dry cereals, sugar, animal feed, milk powder, flour, insulation, cement, paper shavings, plastic granules, sawdust, carbon black, light fibers, detergent powders, dyes, chalk, silica, sand, wood chips

**SPECIFICATIONS**

**Service:** Dry powder or bulk materials compatible with wetted materials. Can detect bulk materials submerged in liquid.  
**Sensitivity:** Minimum bulk density of 1.8 lb/ft<sup>3</sup> (30 g/l), max particle size 0.4' (10 mm).  
**Wetted Materials:** 316 SS.  
**Temperature Limits:** Ambient: -4 to 140°F (-20 to 60°C); Process: -4 to 176°F (-20 to 80°C).  
**Pressure Limit:** 145 psig (10 bar).  
**Power Requirement:** 90-265 VAC, 50/60 Hz; 24 VDC.  
**Power Consumption:** 4 VA.  
**Enclosure:** Aluminum, powder coated.  
**Enclosure Rating:** Weatherproof, NEMA 4X (IP66).  
**Switch Type:** SPDT.  
**Electrical Rating:** 5 A @ 230 VAC.  
**Electric Connections:** Screw terminals.  
**Conduit Connection:** 3/4" female NPT.  
**Process Connection:** 1-1/2" male NPT.  
**Indication Lights:** External: Red LED; Internal: Green and red LED's.  
**Sensing Delay:** (Max) covered probe: 2 s; Uncovered probe: 3 to 7 s.  
**Time Delay:** Separate settings for covering and uncovering the probe. Adjustable from 2 to 20 s.  
**Weight:** 5.5 lb (2.5 kg).

**MODEL CHART**

Model	Description
TFLS-W11SR1	Tuning fork level switch

Contact factory for fork extension options in stainless steel.

MODEL CTF | PROXIMITY® BY DWYER

# MINI TUNING FORK LEVEL SWITCH

Compact, Cost Effective, DIN Connection

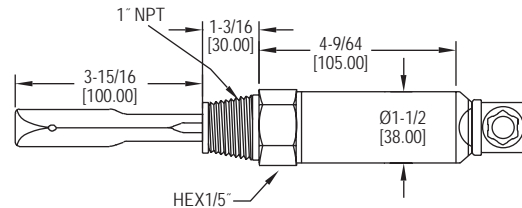
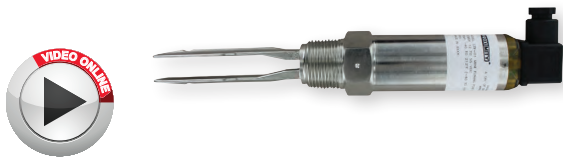

The **Model CTF Mini Tuning Fork Level Switch** is an ideal choice for level control of powders. The CTF incorporates a piezoelectric crystal that vibrates the fork at its natural frequency, when contact material is present it dampens the vibrations and the switch changes state. This series offers a PNP/NPN configurable output.

**FEATURES/BENEFITS**

- DIN connection and compact size allows for application in places a larger tuning fork level switch may not be suitable, providing great versatility
- No mechanical moving parts with no routine maintenance required
- Unaffected by the dielectric constant of the sensed material, making it superior to a capacitance level switch for applications where the dielectric constant is too low, where there is more than one material being used in one vessel, and when material moisture content can change
- Ideal for applications where the bulk density is too low for a rotating paddle level switch

**APPLICATIONS**

- Chemical processing
- Pulp and paper processing
- Mining
- Food and beverage

**SPECIFICATIONS**

**Service:** Dry powder compatible with wetted materials.  
**Sensitivity:** Min. bulk solid density: 4.4 lb/ft<sup>3</sup> (70 g/l).  
**Wetted Materials:** Tuning Fork: 316 L SS; Process connection: 304 SS.  
**Temperature Limits:** Ambient: -40 to 140°F (-40 to 60°C); Process: -40 to 212°F (-40 to 100°C).  
**Pressure Limit:** 600 psi (40 bar).  
**Power Requirement:** 12-55 VDC.  
**Power Consumption:** 10 mA @ 12-24 VDC; 0.5 W (max.).  
**Enclosure:** Aluminum, painted.  
**Enclosure Rating:** IP65.  
**Switch Type:** 3-wire PNP/NPN output.  
**Electrical Rating:** 350 mA (max) @ 12 to 55 VDC.  
**Conduit Connection:** Valve plug DIN 43650.  
**Process Connections:** 1" male NPT.  
**Indication Lights:** External red LED.  
**Sensing Delay:** Max. covered probe: 1 to 3 s.; Uncovered probe: 1 to 3 s.  
**Weight:** 2.2 lb (1.0 kg).

**MODEL CHART**

Model	Description
CTF-01	Mini tuning fork level switch



MODEL DBLM | PROXIMITY® BY DWYER



# MINI-BIN DRY BULK LEVEL MONITOR

Compact, 4-Vane Paddle

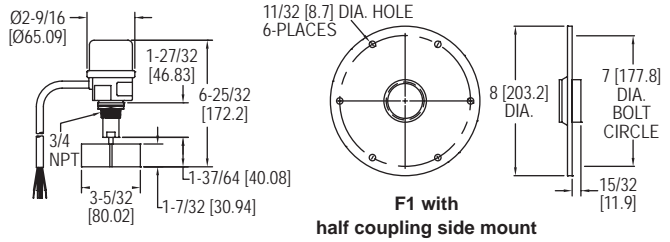

The **Model DBLM Mini-Bin Dry Bulk Level Monitor** provides reliable level sensing for dry bulk solids where mounting space is limited. Model DBLM Mini-Bin operates by using a 1 rpm synchronous motor to rotate a four vane, plastic paddle, and when material surrounds paddle and impedes rotation, the motor is de-energized and triggers a SPDT snap switch. Mount the Mini-Bin with optional 1-1/4" to 3/4" reducer to replace standard size units.

**FEATURES/BENEFITS**

- Compact, side mount control reports high, intermediate, and low level conditions, eliminating overflows, choking, clogs or empty vessels
- Unaffected by the dielectric constant of the sensed material, making it superior to a capacitance level switch for applications where the dielectric constant is too low, where there is more than one material being used in one vessel, and when material moisture content can change

**APPLICATIONS**

- Mining
- Food and beverage
- Grain silos
- Hoppers

MODEL CHART	
Model	Power Supply
DBLM3040	110 VAC
DBLM3140	220 VAC

**SPECIFICATIONS**

**Service:** Dry bulk solids.  
**Wetted Materials:** Polycarbonate paddle, SS shaft, PTFE washer.  
**Temperature Limits:** -4 to 140°F (-20 to 60°C).  
**Enclosure Rating:** Polycarbonate, NEMA 1 (IP10).  
**Switch Type:** SPDT snap switch.  
**Electrical Rating:** 3 A @ 250 VAC.  
**Power Requirements:** 110 VAC, 50/60 Hz, 220 VAC optional, consult factory.

**Power Consumption:** 1.5 watt.  
**Electrical Connections:** 18 AWG, 12" leads wrapped in conduit.  
**Process Connection:** 3/4" male NPT, optional flange and 1-1/4" to 3/4" reducer.  
**Mounting Orientation:** Side mount.  
**Weight:** 0.77 lb (350 g).  
**Agency Approvals:** CE.

**ACCESSORIES**

Model	Description
F1	8" x 1-1/4" NPT flexible carbon steel mounting flange
A-335	1-1/4" to 3/4" reducer 220

SERIES PLS2 | PROXIMITY® BY DWYER



# PADDLE LEVEL SWITCH

3 Sensitivity Settings, Top or Side Mounting

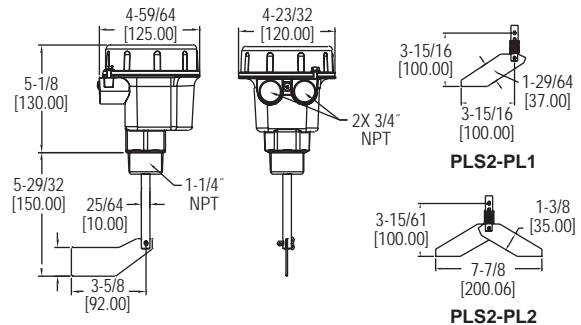

The **Series PLS2 Paddle Level Switch** is an electromechanical level switch designed for level monitoring of bulk materials. The rotating measuring vane is driven by a brushless synchronous motor at one revolution per minute and as product builds up, the paddle rotation is impeded and the resulting motor torque activates the output switch and stops the motor. The PLS2 is designed with the industry standard 1-1/4" male NPT connection and unit can be side or top mounted.

**FEATURES/BENEFITS**

- Torque adjusting mechanism eliminates the need for different sized paddles
- 3 sensitivity settings for spring force can be set for light to very sticky materials
- Brushless synchronous motor assures long term reliability and efficiency
- Motor shuts ceases operation when paddle stalls
- Screw cover for easy access with no worries about losing bolts or screws
- Top or side mountable for added installation flexibility
- Unaffected by the dielectric constant of the sensed material, making it superior to a capacitance level switch for applications where the dielectric constant is too low, where there is more than one material being used in one vessel, and when material moisture content can change

**APPLICATIONS**

- Mining
- Food and beverage
- Silos
- Hoppers

MODEL CHART	
Model	Description
PLS2-E-1-1	Explosion-proof paddle level switch, 115 VAC power supply
PLS2-E-1-2	Explosion-proof paddle level switch, 230 VAC power supply
PLS2-E-1-3	Explosion-proof paddle level switch, 24 VDC power supply

**Note:** Models include single sided non-spring paddle.

**SPECIFICATIONS**

**Service:** Dry powder or bulk materials compatible with wetted materials.  
**Wetted Materials:** Paddle: 304 SS; Exposed shaft: 303 SS; Shaft seal: NBR; Process connection: Aluminum.  
**Temperature Limits:** Process: -13 to 176°F (-25 to 80°C); Ambient: -4 to 140°F (-20 to 60°C).  
**Pressure Limit:** 11.6 psi (0.8 bar).  
**Power Requirement:** Select by model number: 115 VAC, 230 VAC or 24 VDC.  
**Power Consumption:** AC versions: 4 VA; DC version: 2.5 watt.  
**Enclosure:** Aluminum, powder coated.  
**Enclosure Rating:** NEMA 4 (IP66); Rated for Class II & III, Div. 1, Group E, F, G.

**Switch Type:** SPDT micro switch.  
**Electrical Rating:** 5 A @ 250 VAC, 3 A @ 30 VDC.  
**Electric Connections:** Screw terminals.  
**Conduit Connection:** 3/4" female NPT.  
**Process Connection:** 1-1/4" male NPT.  
**Mounting Orientation:** Side or top mounting.  
**Sensitivity:** Min. material density of 6 lb/ft³ (96 kg/m³).  
**Permitted Mechanical Loading:** Standard shaft: 67 lbf (300 N) max; Optional extension: 22 lbf (100 N) max.  
**Weight:** 2.6 lb (1.2 kg).  
**Agency Approvals:** CE, FM.

**ACCESSORIES**

Model	Description
PLS2-PL1	Single sided spring paddle
PLS2-PL2	Double sided spring paddle
PLS2-EX1	8.5" shaft extension
PLS2-EX2	19.6" shaft extension
PLS2-EX3	39.4" shaft extension
PLS2-EX4	78.7" shaft extension





# PADDLE LEVEL SWITCH

Weatherproof and Explosion Proof Option, Rotary Paddle Level Control, Top or Side Mounting for Dry Bulk Materials

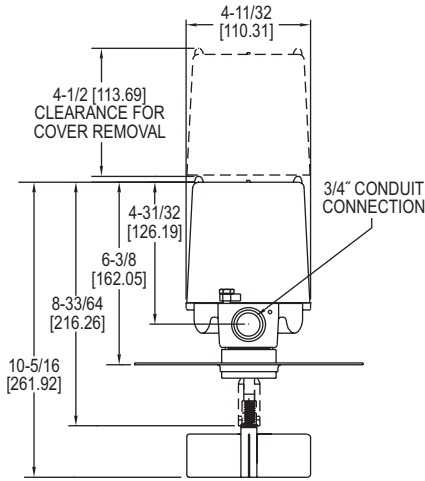

ISOLATED  
MAGNETIC DRIVE

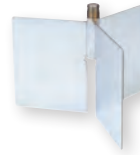

PDL-1  
Minimum bulk density  
of 5 lb/ft<sup>3</sup> (80 kg/m<sup>3</sup>).



PDL-2  
Minimum bulk density  
of 30 lb/ft<sup>3</sup> (481 kg/m<sup>3</sup>).



PDL-3  
Minimum bulk density of 30 lb/ft<sup>3</sup> (481 kg/m<sup>3</sup>). Fits through a 1-1/4" coupling eliminating the need for a mounting flange.



PDL-4  
Minimum bulk density of 70 lb/ft<sup>3</sup> (1122 kg/m<sup>3</sup>). Fits through 1-1/4" coupling eliminating the need for a mounting flange.

The Series PLS Paddle Level Switch uses a 1 rpm synchronous motor to rotate a paddle and sense the presence of dry powder or bulk materials. Movement is impeded when product comes into contact with the paddle and the resulting motor torque activates the output switches and stops the motor. The PLS is designed with the industry standard 1-1/4" male NPT connection and mounting flanges.

**FEATURES/BENEFITS**

- Magnetic drive isolates and completely seals the control head from the process and environment preventing material or dust from entering the control head
- Motor shuts-off when paddle stalls increasing motor life, preventing motor burnout, and decreasing power usage
- Slip clutch design enabled by the magnetic drive that prevents damage to motor and drive mechanism from sudden or excessive loading on the paddle
- Status indication light on weatherproof models
- Screw cover on the enclosure for easy access with no worries about losing bolts or screws
- Modular design to allow field installation of any paddle, flanges, shaft extensions, or shaft guards
- Flexible coupling available for protection of the paddle and drive from side loads, surges or impacts. Recommended for top mount applications with shaft extension and applications with large or heavy materials

**APPLICATIONS**

- Mining
- Food and beverage
- Silos
- Hoppers

MODEL CHART		
Paddle Model	Flange Model	Description
PDL-1	FLG-CSH	Carbon steel with half coupling
PDL-2	FLG-CSF	Carbon steel with full coupling
PDL-3	FLG-SSH	316 SS with half coupling
PDL-4	FLG-SSF	316 SS with full coupling

**Note:** Contact the factory for shaft extensions, protective shields, and other options. More detailed information available in our Measurement & Control for Powder, Dust, and Bulk Materials Catalog.

SPECIFICATIONS	
<b>Service:</b>	Dry powder or bulk materials compatible with wetted materials.
<b>Sensitivity:</b>	Min material density of 5 lb/ft <sup>3</sup> (80 kg/m <sup>3</sup> ), max of 200 lb/ft <sup>3</sup> (3200 kg/m <sup>3</sup> ).
<b>Wetted Materials:</b>	Paddles: 316 SS; Exposed shaft: 316 SS; Shaft seal: PTFE; Mounting boss: Aluminum; Flexible coupling: 316 SS; Mounting flanges: Carbon steel or 316 SS; Shaft extension and shaft guards: Galvanized steel or 316 SS.
<b>Temperature Limits:</b>	Standard construction: Process: -40 to 300°F (-40 to 148.9°C); Ambient: -40 to 185°F (-40 to 85°C); High temperature option: Process: -40 to 500°F (-40 to 260°C); Ambient: -40 to 185°F (-40 to 85°C).
<b>Pressure Limit:</b>	30 psig (2.07 bar) max for .5 micron or larger material.
<b>Power Requirement:</b>	Select by part number: 110 to 120 VAC, 230 VAC, 24 VAC, 48 VAC or 12 VDC.
<b>Power Consumption:</b>	Weatherproof models: 5 watts; Explosion-proof models: 3 watts.
<b>Enclosure:</b>	Aluminum, powder coated.
<b>Enclosure Rating:</b>	Weatherproof (W, WH construction): NEMA 4X (IP66); Explosion-proof (E, EH construction): NEMA 4X (IP66) and rated for Class I, Div. 1 & 2, Groups C & D, Div. 1 & 2, Groups E, F, & G.
<b>Switch Type:</b>	SPDT or optional DPDT snap switch.
<b>Electrical Rating:</b>	15 A @ 120.
<b>Electric Connections:</b>	Screw terminals.
<b>Conduit Connection:</b>	3/4" female NPT.
<b>Process Connection:</b>	1-1/4" male NPT. Optional flange.
<b>Indication Light:</b>	Red LED that activates when switch is made or when switch is not made with RL option (Not available on explosion-proof models).
<b>Options:</b>	Time delay relay, high temperature construction, top mount, shaft extensions, shaft shields, flexible couplings, other power voltages, reversed light.
<b>Agency Approvals:</b>	cUL approved as an auxiliary device or as an auxiliary device for hazardous locations.
<b>Weight:</b>	Control head only: 4 lb (1.81 kg).

MODEL CHART - CONTROL ASSEMBLIES	
Model	Description
PLS-W-S-1-0-0-0-0	Weatherproof construction, SPDT switch, 120 VAC power supply. Order paddles and flanges separately.
PLS-W-S-1-3-0-0-0	Weatherproof construction, SPDT switch, 120 VAC power supply, includes PDL-3 paddle.
PLS-W-S-1-2-CSH-0-0	Weatherproof construction, SPDT switch, 120 VAC power supply, includes PDL-2 paddle and FLG-CSH flange.

\*316 SS mounting boss available.

Level Switches,  
Paddle

# ULTRA-MAG™ EXPLOSION-PROOF LEVEL SWITCHES FOR POWDER & BULK SOLIDS

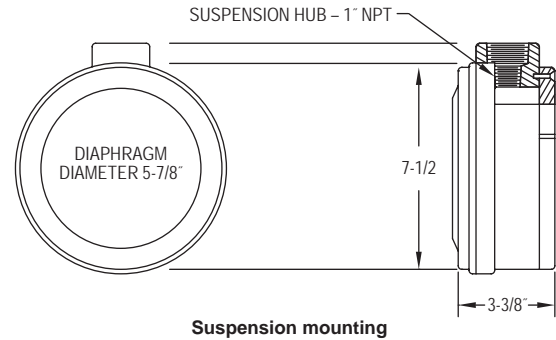
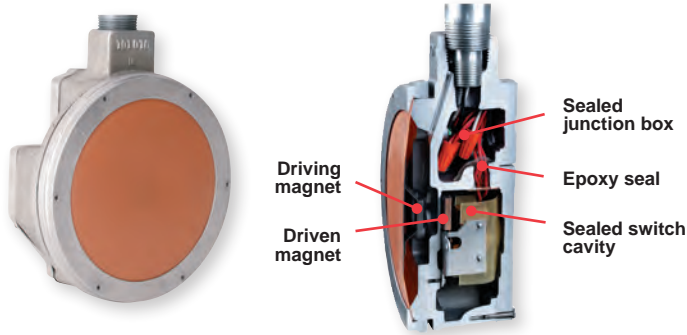

The **Series E, G, & P Ultra-Mag™ Explosion-Proof Level Switches For Powder & Bulk Solids** are explosion-proof series of level switches for powder and bulk solids that utilize a unique magnetic linkage and diaphragm design to sense the presence of powder and bulk solids in a variety of bins, vessels, and hoppers.

## FEATURES/BENEFITS

- Uses a unique magnetic linkage which isolates the electrical compartment from controlled product, reducing maintenance and improving sensitivity
- Sealed switch compartment and sealed leads yield the exceptionally reliable operation
- A wide selection of diaphragms and switches is available with choices of flange or suspension mounting to fit a specific application
- Extremely sensitive indication and very economical
- Magnetic linkage makes this simple explosion-proof diaphragm switch the most rugged and reliable level control for a variety of products

## APPLICATIONS

- Mining
- Food and beverage
- Silos
- Hoppers

## MOUNTING SELECTION

A choice of either suspension or flange mounting is available to match your application. Flange mounting is the best choice for control of low or intermediate level in vessels containing granular product that does not "bridge", "rathole", or otherwise build up on vessel walls. Choose suspension mounting for high level in vessels and for better operation with "bridging" product. ❶

**Note:** The mounting configuration is represented by the letter "S" for suspension or "F" for flange which is the second digit in the part number. ❷

## DIAPHRAGM SELECTION

A wide variety of diaphragms are available to match product bulk density, flowability, abrasiveness and temperature requirements while providing maximum sensitivity. The best choice for vessels subject to pressure or vacuum is "breathable" fabric (P Series), requiring no venting. Non-porous elastomer (G Series) type diaphragms are the best choice for more abrasive product and broader temperature range applications. Venting is always required with the G series and if used in pressurized vessels, venting to the tank atmosphere is required to allow pressure equalization. A slide rule "Diaphragm Selector" is available from the factory to help you choose the diaphragm best suited to your application.

## SPECIFICATIONS

**Service:** Compatible powder or bulk solids.  
**Wetted Materials:** Mounting Flange: See model chart. Aluminum or 304 SS; Diaphragm: See model chart. Urethane, Buna-N, PTFE, silicone rubber, polyester, fluoroelastomers, white Buna-N (food grade), or EPDM.  
**Temperature Limits:** Depends on diaphragm material, see model chart. Standard switch: -40 to 185°F (-40 to 85°C); High temperature switch: -40 to 350°F (-40 to 176°C).  
**Pressure Limit:** 60 psig (4.14 bar).  
**Enclosure Rating:** General purpose or weatherproof and explosion-proof. See model chart.  
**Switch Type:** See model chart.  
**Electrical Rating:** See model chart.  
**Electrical Connections:** 18 gage solid core, 600 volt TEW 105°C, style 1015. Epoxy sealed at conduit entrance. 12" (304.8 mm) long.  
**Conduit Connection:** 1/2" female NPT.  
**Process Connection:** For flanged models standard is 8-3/8" (212.725 mm) diameter bolt hole circle.  
**Mounting Orientation:** Flange mount or suspend depending on model.  
**Set Point Adjustment:** Internal screw.  
**Options:** Suspension kits and flange adapter rings.  
**Weight:** 7 lb (3.18 kg).  
**Agency Approvals:** CSA and UL.

❶ Suspension and Flange Mounting Kits: See page 327 (Ultra Mag™)

❷ Part Number: See page 327 (Ultra Mag™)

# ULTRA-MAG™ EXPLOSION-PROOF LEVEL SWITCHES FOR POWDER & BULK SOLIDS

## DIAPHRAGM SELECTION GUIDE

Product	Suggested Diaphragm*	Product	Suggested Diaphragm*
Abrasive	3D	Polypropylene Powder	7A
Aggregate	3D	Polypropylene Resin	17
Alumina	3D	Polystyrene Beads	3D
Ash, Dry	3D	Pot Ash	3D
Baking Powder	7B	Powdered Metal	3D
Baking Soda	7B	Powdered Ore	3D
Barite	3D	PVC Powder	7A
Bark, Ground	6G	PVC Resin	17
Barley, Ground or Meal	17	Rice	17
Barley, Whole	4B	Rye	3D
Beans, Edible	4B	Salt	3D
Bentonite	3D	Sand, Dry	3D
Bond, Foundry	17	Sand, Dry Silica	3D
Carbon Black	7A	Sand, Foundry Prepared	5A
Cement, Klinker	8A	Sand, Shake Out	3D
Cement, Portland	4B	Sawdust, Dry	6G
Chips, Hogged Fuel	6G	Sea Coal	3D
Coal	3D	Sesame Seed	3D
Compost	5A	Shale, Crushed	3D
Core Sand, Foundry	3D	Silica, Flour	3D
Corn, Shelled	8A	Sludge, Sewage Dried	1A
Diatomaceous Earth	7A	Sludge, Sewage, Ground	1A
Drill Mud	3D	Soda Ash	3D
Flour	7B	Soybeans, Cracked	3D
Fly Ash	3D	Soybean, Flake	7A
Glass Batch	3D	Soybean, Flour	7A
Gravel	3D	Soybean Meal	3D
Iron Ore, Crushed	3D	Soybean, Whole	3D
Kaolin Clay	3D	Sugar Beets, Whole	6H
Lime, Hydrated	5A	Sugar Refined	7B
Lime, Stone	3D	Sunflower Seed	7A
Oats	4B	Taconite Pellets	3D
Peanuts in Shell	7A	Talcum Powder	3D
Peanuts, Shelled	3D	Walnut Shells, Crushed	3D
Perlite	7A	Wheat	8A
Phosphate, Rock	3D	Wheat, Wet	5A
Polyethylene Powder	7A	Wood, Chips	6G
Polyethylene Resin	17	Wood, Dust	6G
Polypropylene Fluff	7A		

\*Diaphragm codes become 4th and 5th characters in model number

## SUSPENSION MOUNTING

Suspension mounting is normally used for high level monitoring in vessels. For product over 20 lb/ft<sup>3</sup>, the level switch (diaphragm face) should be located about 1/3 of the distance from the vessel wall to the point of entry of the product. For product less than 20 lb/ft<sup>3</sup>, the unit should be located closer to the point of entry of the product, about 1/2 the distance from the vessel wall to the point of entry. Pressure required to depress the diaphragm and trip the switch is in the range of 5 to 15 oz in the horizontal direction (perpendicular to the diaphragm). Suspension mounting provides the easiest vertical adjustment capability, greatest sensitivity and best maintenance conditions.

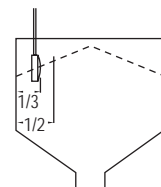

## SUSPENSION ASSEMBLY KITS

Pre-assembled kits are available from the factory, or you can build your own kits using standard pipe fittings shown in our Proximity Bill of Materials (Form No. 101). Pipes and fittings are normally galvanized steel, but aluminum and SS pipes and fittings are available. Units are secured to a steel cover plate that rests on a rectangular steel flange welded into the top of the vessel. Aluminum and stainless coverplates and flanges are also available. Standard 48" L x 1" pipe provides working depth (WD) up to 48". Longer pipe (to provide greater WD) is available. GS Series switches have upper (L1 = 28" standard) and lower (L2 = 20" standard) 1" pipes, with a tee (for stilling pot) in between. A stilling pot is required to equalize pressure and keep dirt from building up behind the diaphragm. PS series require a 1/2" conduit in 1" suspension pipe for explosion-proof applications. The 1/2" conduit (56" standard length) is a standard part of the GS series assembly.

## MODEL CHART - ALUMINUM FLANGE ADAPTER RINGS

Model	Tank Outside Diameter	Model	Tank Outside Diameter
126-009	15"	126-016	84"
126-010	30"	126-017	96"
126-011	36"	126-018	10"
126-012	42"	126-019	12"
126-013	48"	126-020	14"
126-014	60"	126-021	24"
126-015	72"		

## MODEL CHART - "P" AND "G" SERIES SUSPENSION ASSEMBLY KITS

Model	Description
901-409	"P" Series suspension assembly includes 1/2" pipe (56" std length), 1" pipe (48" std length), 1" pipe coupling, 1-1/2 NPT strain relief on 1" pipe. Galvanized mild steel pipe, explosion proof, standard.
901-412	"G" Series suspension assembly includes 1/2" pipe (56" std length), watertight strain relief and 1" coupling, upper 1" pipe (28" std length), lower 1" pipe (20" std length), strain relief with 1-1/2" NPT, 1"x1"x1" Tee, 1" street ell and 1" pipe-4" long stilling pot. Galvanized steel pipe, explosion proof, standard.

**Note:** Specials include aluminum or stainless steel assemblies. Flange port and cover assemblies are sold separately. Consult factory for details.

## MODEL CHART

Example	E	-X	-G	-S	-D	-3D	-A	E-X-G-S-D-3D-A*
<b>Certification 1</b>	E							Ultra-Mag™ explosion-proof level switches
<b>Certification 2</b>		EX						Explosion-proof (UL & CSA) Class I, Div I & II, Groups C & D; Class II, Div I & II, Groups E, F, & G Explosion-proof (CSA) Class II, Div I & II, Groups F & G General purpose (no code)
<b>Basic Magnetic Pressure Sensing Series</b>			G	P				Elastomeric diaphragm-venting required*. (Diaphragms 1A - 8A) Breathable fabric diaphragm-no venting required. (Diaphragms 16 & 17 only)
<b>Mounting (Top = Suspension/ Side = Flanged)</b>				S	F	T		Suspended (G series require suspension vent fittings)* Subtract 10 lbs./cu. ft.-greater sensitivity Flanged, aluminum standard Flanged, 304 SS
<b>Housing Material</b>					D	A	E	Aluminum Aluminum, anodized Aluminum, epoxy coated
<b>Diaphragm Material (Temperature) (Bulk Density)</b>						3D		Urethane, .031" thick, (10 to 150°F), (> 30 lb/ft <sup>3</sup> )
						3E		Urethane, orange, .062" thick, (10 to 150°F), (> 90 lb/ft <sup>3</sup> )
						4B		Buna-N, black, .020" thick, (-20 to 212°F), (20 to 90 lb/ft <sup>3</sup> )
						5A		PTFE/glass on silicone rubber, .024" thick, (-40 to 350°F), (> 35 lb/ft <sup>3</sup> )
						6D		Silicone rubber, gray, .062" thick, (-40 to 350°F), (15 to 30 lb/ft <sup>3</sup> )
						6E		Silicone rubber on glass, red, .032" thick, (-40 to 350°F), (> 90 lb/ft <sup>3</sup> )
						6G		6C" w/urethane overlay, (-40 to 350°F), (wood chips diaphragm with "A2")
						7A		Silicone rubber on glass (White), .015" thick, (-40 to 350°F), (5 to 40 lb/ft <sup>3</sup> )
						7B		Buna-N (food applications-white), .060" thick, (-20 to 212°F), (30 to 90 lb/ft <sup>3</sup> )
						8A		EPDM, black, .036" thick, (-40 to 275°F), (40 to 90 lb/ft <sup>3</sup> )
						16		Polyester filter fabric, white, 150 micron permeability, (-30 to 275°F), (30 to 90 lb/ft <sup>3</sup> )
						17		Polyester nitex, white, 15 micron permeability (-30 to 275°F), (30 to 90 lb/ft <sup>3</sup> )
<b>Switch Type</b>							A	Standard, SPDT, 15 A @ 125, 250 VAC
							T	High temp, SPDT, 5 A @ 125, 250 VAC; 24 VDC**
							V	High vibration, SPDT, 15 A @ 125, 250 VAC
							G	Gold contacts, SPDT, 1 A @ 125 VAC, 1/2 A @ 24 VDC
<b>Special Controls</b>							A2	Wood chip control (with "6G" diaphragm only)
							A3	High sensitivity actuator (for very light product)

\*GS - G series suspended controls require suspension vent fittings. \*\*Non-UL/CSA listed

**Note:** The "EX" prefix must be added to the 6-digit model number for "explosion-proof standard". General purpose units do not require the "EX" or other prefix.

Level Switches, Diaphragm

# SUBMERSIBLE LEVEL TRANSMITTERS

Perfect for Ground Water and Wells, Lightning Protected, Standard 72 Hour Lead Time



SBLT2



SBLTX



NOW WITH 72 HOUR  
OUT OF STOCK LEAD TIME!

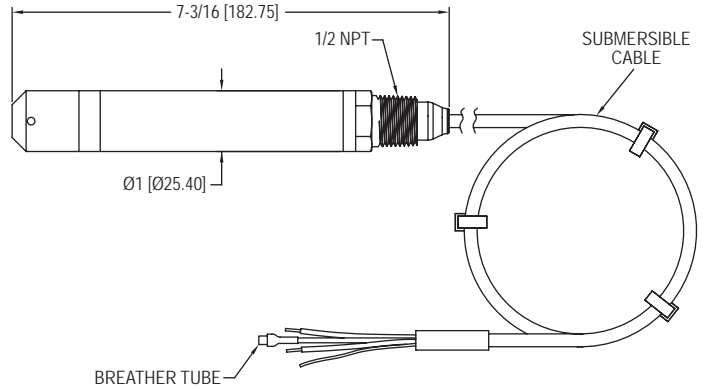

The Series SBLT2 & SBLTX Submersible Level Transmitters are manufactured for years of trouble free service. These series measure the height of liquid above the position in the tank referenced to atmospheric pressure. The transmitter consists of a piezoresistive sensing element, encased in a 316 SS housing.

**FEATURES/BENEFITS**

- Slim design for tight applications with bullet nose design which protects the diaphragm from damage
- Incorporates lightning and surge protection utilizing dual arrestor technology, grounded to case, eliminating both power supply surges and lightning ground strike transients (surge protection is not guaranteed and is not covered by warranty) on SBLT2 models
- Maintenance free filter eliminates particulate or water droplets from entering the transducer
- UL approved intrinsically safe on SBLTX models for use in hazardous locations when used with proper barrier
- 270 lb tensile strength shielded and vented cable
- Excellent chemical compatibility
- NPT connection allows the unit to be rigidly installed in a pipe/conduit, or the addition of a A-625 hanging loop for attaching a chain for pulling out of the installation
- Standard 72 hour lead time ensures minimal downtime

**APPLICATIONS**

- Well monitoring
- Ground water monitoring
- Environmental remediation
- Surface water monitoring
- Down hole
- Water tanks

MODEL CHART			
Model	Range psi* (ft w.c.) [m w.c.]	Cable Length ft (m)	Cable Type
SBLT2-5-40-ETFE	5 (11.54) [3.52]	40 (12.2)	ETFE
SBLT2-10-40-ETFE	10 (23.09) [7.04]	40 (12.2)	ETFE
SBLT2-15-60-ETFE	15 (34.63) [10.56]	60 (18.3)	ETFE
SBLT2-20-60-ETFE	20 (46.18) [14.08]	60 (18.3)	ETFE
SBLT2-5-40	5 (11.54) [3.52]	40 (12.2)	Polyurethane
SBLT2-10-40	10 (23.09) [7.04]	40 (12.2)	Polyurethane
SBLT2-15-60	15 (34.63) [10.56]	60 (18.3)	Polyurethane
SBLT2-20-60	20 (46.18) [14.08]	60 (18.3)	Polyurethane
SBLT2-3.5M-5M	4.97 (11.48) [3.5]	16.40 (5)	Polyurethane
SBLT2-5M-10M	14.21 (32.81) [10]	32.81 (10)	Polyurethane
SBLT2-10M-18M	25.58 (59.06) [18]	59.06 (18)	Polyurethane

\*Configured ranges below 5 psi (11.54' w.c.) (3.52 m w.c.) ±1% FS accuracy  
 Note: For intrinsically safe approval, change model number from SBLT2 to SBLTX.  
 For custom ranges or cable lengths, contact factory.

**SPECIFICATIONS**

**Service:** Compatible liquids.  
**Wetted Materials:** Body: 316 SS, 316L SS; Bullet nose: PVC; Cable: Polyether polyurethane or ETFE; Seals: Fluoroelastomer.  
**Accuracy:** ±0.25% FS.  
**Temperature Limit:** SBLT2: Polyurethane: 0 to 150°F (-18 to 66°C); ETFE: 0 to 200°F (-18 to 93°C); SBLTX -4 to 176°F (-20 to 80°C); Polyurethane: -4 to 149°F (-20 to 65°C).  
**Compensated Temperature Range:** SBLT2: 0 to 140°F (-18 to 60°C); SBLTX: 0 to 176°F (-18 to 80°C).  
**Thermal Effect:** ±0.02% FS/°F.  
**Pressure Limit:** 2X FS.  
**Power Requirement:** SBLT2: 10-30 VDC (≤ 1000 ft (305 m) of cable); SBLTX: 10-28 VDC.  
**Output Signal:** 4-20 mA DC, 2-wire.  
**Response Time:** 50 ms.  
**Max. Loop Resistance:** 900 Ω at 30 VDC.  
**Electrical Connections:** Wire pigtail.  
**Mounting Orientation:** Suspended in tank below level being measured.  
**Electrical Protection:** SBLT2: Lightning and surge protection; SBLTX: None.  
**Weight:** 2.2 lb (1.0 kg).  
**Agency Approvals:** SBLT2: CE; SBLTX: CE, cULus intrinsically safe for Class I, Div. 1, Groups A, B, C, D; Class II, Div. 1, Groups E, F, G; Class III Div. 1. (according to control drawing 001833-43)\*.  
 \*Up to 196' (59.5 m) for ETFE cable; Up to 333' (101.5 m) for polyurethane cable

**OPTIONS**

Model	Description
-P1	1/4" NPT male
-P2	1/4" NPT female
-P3	1/4" BSPT male ISO 228 R
-P4	1/4" BSPT female ISO 228 RC
-P11	3/4" clean-out type



-P11 option

**ACCESSORIES**

Model	Description
MTL5541	Galvanic barrier
MTL7706	Intrinsically safe zener barrier
A-297	Dessicant filter for vent tube. Removes humidity for protection of the sensor. Changes color to show saturation
A-625	316 SS cable hanger use with NPT option for attaching chain for easy pulling out of application



A-297

A-625



# MINIATURE SUBMERSIBLE LEVEL TRANSMITTER

Only 0.63" (16 mm) in Diameter, Perfect for Wells and Boreholes, Low Power Models for Telemetry Systems

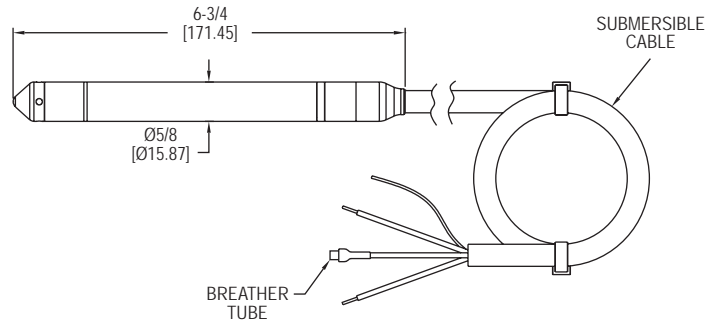

The Series MBLT Miniature Submersible Level Transmitter measures the height of liquid above the position in the tank referenced to atmospheric pressure. The transmitter consists of a piezoresistive sensing element, encased in a 0.63" (16 mm) diameter 316 SS housing.

**FEATURES/BENEFITS**

- Slender 0.63" (16 mm) diameter design fits in narrow openings
- Constructed for years of trouble free service with welded 316 SS body and 316 SS nose cap
- Body top is 316 SS and tapered to prevent damage or snares when pulling the unit out of the installation
- ±0.10% or ±0.25% FS accuracy output is more precise than BFSL or BSL rated outputs used by most competitors
- Maintenance free filter eliminates particulate or water droplets from entering the transducer
- Comes with a choice of polyether polyurethane or ETFE cable materials for excellent chemical compatibility
- Incorporates lightning and surge protection, eliminating both power supply surges and lightning ground strike transients (surge protection is not guaranteed and is not covered by warranty)

**APPLICATIONS**

- Ballast tanks
- Ground water monitoring
- Surface water monitoring
- Dewatering
- Down hole
- Remote telemetry
- Remote flood monitoring
- Narrow conduit or pipe installations
- Remediation and environmental monitoring

**SPECIFICATIONS**

**Service:** Compatible liquids.  
**Wetted Materials:** Body and nose: 316 SS; Cable: Polyether polyurethane or ETFE; Seals: Fluoroelastomer; Label: Polyolefin.  
**Accuracy:** ±0.25% or ±0.10% FS\*\*.  
**Temperature Limits:** -4 to 176°F (-20 to 80°C).  
**Compensated Temperature Limits:** 0.25%: (0 to 70°C); 0.10%: (0 to 60°C).  
**Thermal Effect:** 0.25%: ±0.45% FS TEB; 0.10%: ±0.30% FS TEB.  
**Pressure Limit:** 2x FS.  
**Power Requirements:** Current output: 10 to 33 VDC; Voltage output: 8 to 33 VDC; 5 mA max (no load).  
**Output Signal:** 4 to 20 mA DC 2-wire or 0 to 5 V\* (model depending).  
**Response Time:** < 50 ms.  
**Max Loop Resistance:** 1000 Ω @ 30 VDC (current output).  
**Voltage Output Impedance:** 10 Ω + 4.4 Ω / 100' cable (voltage output).  
**Electrical Connections:** Wire pigtail.  
**Mounting Connection:** Suspended below point being monitored.  
**Electrical Protection:** Surge/lightning protected per EN61000-4-5, Class 5.  
**Weight:** Body: 0.235 lb (0.107 kg); Cable: 0.037 lb (0.017 kg) per foot.  
**Agency Approvals:** CE.

\*Consult factory for additional outputs.  
 \*\*4.3 to 4.9 psi (10 to 11.54 in w.c.) configured ranges ±0.30% FS accuracy

**OPTIONS**

For custom ranges, cable lengths, or ETFE cable, contact the website.

**ACCESSORIES**

Model	Description
A-297	Dessicant filter for vent tube. Removes humidity for protection of the sensor. Changes color to show saturation



A-297

MODEL CHART					
4 to 20 mA output Model ±0.10%	4 to 20 mA output Model ±0.25%**	0 to 5 V output Model ±0.25%**	Range psi (' w.c.) [m w.c.]	Cable Length	Cable Type
-	MBLT-2SC-IVPP-5-40	MBLT-2SC-VVPP-5-40	5 (11.54) [3.52]	40'	Polyether polyurethane
-	MBLT-2SC-IVPF-15-40	MBLT-2SC-VVPF-15-40	6.50 (15) [4.57]	40'	Polyether polyurethane
-	MBLT-2SC-IVPM-5-12.2	MBLT-2SC-VVPM-5-12.2	7.10 (16.40) [5]	12.2 m	Polyether polyurethane
-	MBLT-2SC-IVPM-10-30**	MBLT-2SC-VVPM-10-30**	14.22 (32.84) [10]	9.14 m	Polyether polyurethane
MBLT-2SB-IVPF-20-40	MBLT-2SC-IVPF-20-40	MBLT-2SC-VVPF-20-40	8.66 (20) [6.10]	40'	Polyether polyurethane
MBLT-2SB-IVPF-30-50	MBLT-2SC-IVPF-30-50	MBLT-2SC-VVPF-30-50	12.99 (30) [9.14]	50'	Polyether polyurethane
MBLT-2SB-IVPM-10-15.2	MBLT-2SC-IVPM-10-15.2	MBLT-2SC-VVPM-10-15.2	14.21 (32.81) [10]	15.2 m	Polyether polyurethane
MBLT-2SB-IVPF-50-70	MBLT-2SC-IVPF-50-70	MBLT-2SC-VVPF-50-70	21.65 (50) [15.24]	70'	Polyether polyurethane
MBLT-2SB-IVPM-20-26	MBLT-2SC-IVPM-20-26	MBLT-2SC-VVPM-20-26	28.42 (65.62) [20]	26 m	Polyether polyurethane
MBLT-2SB-IVPM-30-36	MBLT-2SC-IVPM-30-36	MBLT-2SC-VVPM-30-36	42.63 (98.43) [30]	36 m	Polyether polyurethane
MBLT-2SB-IVPF-100-120	MBLT-2SC-IVPF-100-120	MBLT-2SC-VVPF-100-120	43.31 (100) [30.48]	120'	Polyether polyurethane
MBLT-2SB-IVPM-40-46	MBLT-2SC-IVPM-40-46	MBLT-2SC-VVPM-40-46	56.83 (131.23) [40]	46 m	Polyether polyurethane
MBLT-2SB-IVPF-150-170	MBLT-2SC-IVPF-150-170	MBLT-2SC-VVPF-150-170	64.96 (150) [45.72]	170'	Polyether polyurethane
MBLT-2SB-IVPM-60-66	MBLT-2SC-IVPM-60-66	MBLT-2SC-VVPM-60-66	85.25 (196.85) [60]	66 m	Polyether polyurethane
MBLT-2SB-IVPF-200-220	MBLT-2SC-IVPF-200-220	MBLT-2SC-VVPF-200-220	86.62 (200) [60.96]	220'	Polyether polyurethane
MBLT-2SB-IVPF-350-370	MBLT-2SC-IVPF-350-370	MBLT-2SC-VVPF-350-370	151.58 (350) [106.68]	370'	Polyether polyurethane
MBLT-2SB-IVPM-100-106	MBLT-2SC-IVPM-100-106	MBLT-2SC-VVPM-100-106	142.09 (328.08) [100]	106 m	Polyether polyurethane
MBLT-2SB-IVPM-200-206	MBLT-2SC-IVPM-200-206	MBLT-2SC-VVPM-200-206	284.18 (656.17) [200]	206 m	Polyether polyurethane
MBLT-2SB-IVPF-690-710	MBLT-2SC-IVPF-690-710	MBLT-2SC-VVPF-690-710	298.83 (690) [210.31]	710'	Polyether polyurethane

\*\*4.3 to 4.9 psi (10 to 11.54 in w.c.) configured ranges ±0.30% FS accuracy

# SUBMERSIBLE LEVEL TRANSMITTERS

Perfect for Sludge and Slurries, Lightning Protected, Standard 72 Hour Lead Time



PBLT2

PBLTX

NOW WITH 72 HOUR  
OUT OF STOCK LEAD TIME!

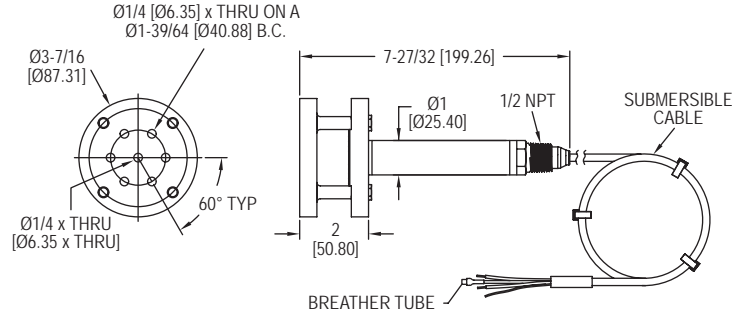

The **Series PBLT2 & PBLTX Submersible Level Transmitters** are manufactured for years of trouble free service in the harshest applications. These Series measure the height of liquid above the position in the tank referenced to atmospheric pressure. The transmitter consists of a piezoresistive sensing element, encased in a 316 SS housing with cage and large diameter 316 SS diaphragm seal.

**FEATURES/BENEFITS**

- Durable cage design with large diameter 316 SS diaphragm seal that is non-clogging and damage resistant to floating solids
- Incorporates lightning and surge protection utilizing dual arrestor technology, grounded to case, eliminating both power supply surges and lightning ground strike transients (surge protection is not guaranteed and is not covered by warranty) on PBLT2 models
- Maintenance free filter eliminates particulate or water droplets from entering the transducer
- UL approved intrinsically safe on PBLTX models for use in hazardous locations when used with proper barrier
- 270 lb tensile strength shielded and vented cable
- Excellent chemical compatibility
- NPT connection allows the unit to be rigidly installed in a pipe/conduit, or the addition of a A-625 hanging loop for attaching a chain for pulling out of the installation
- Standard 72 hour lead time ensures minimal downtime

**APPLICATIONS**

- Wastewater
- Sludge pits, clarifiers, digesters
- Alum tanks
- Chemical storage tanks
- Oil tanks
- Lime slurry
- Sumps
- Reservoirs

**SPECIFICATIONS**

**Service:** Compatible liquids.  
**Wetted Materials:** Body: 316 SS, 316L SS; Cable: Polyether polyurethane or ETFE; Seals: Fluoroelastomer.  
**Accuracy:** ±0.25% FS (includes linearity, hysteresis, and repeatability).  
**Temperature Limit:** PBLT2: 0 to 200°F (-18 to 93°C); PBLTX: ETFE -4 to 176°F (-20 to 80°C); Polyurethane: -4 to 149°F (-20 to 65°C).  
**Compensated Temperature Range:** PBLT2: 0 to 180°F (-18 to 82°C); PBLTX: 0 to 176°F (-18 to 80°C).  
**Thermal Effect:** ±0.02% FS/°F.  
**Pressure Limit:** 2X FS.  
**Power Requirement:** PBLT2: 13-30 VDC; PBLTX: 10-28 VDC.  
**Output Signal:** 4-20 mA DC, two wire.  
**Response Time:** 50 ms.  
**Loop Resistance:** 900 Ω.  
**Electrical Connection:** Wire pigtail.  
**Mounting Orientation:** Suspended in tank below level being measured.  
**Electrical Protection:** PBLT2: Lightning and surge protection, PBLTX: none.  
**Weight:** 4.3 lb (2.0 kg).  
**Agency Approvals:** PBLT2: CE, PBLTX: CE, cULus intrinsically safe for Class I, Div. 1, Groups A, B, C, D; Class II, Div. 1, Groups E, F, G; Class III, Div. 1. (According to control drawing 001833-44)\*.  
 \*Up to 196' (59.5 m) for ETFE cable; Up to 333' (101.5 m) for polyurethane cable

Level Transmitters,  
Submersible

MODEL CHART			
Model	Range psi* (ft w.c.) [m w.c.]	Cable Length ft (m)	Cable Type
PBLT2-5-40	5 (11.54) [3.52]	40 (12.2)	ETFE
PBLT2-10-40	10 (23.09) [7.04]	40 (12.2)	ETFE
PBLT2-15-60	15 (34.63) [10.56]	60 (18.3)	ETFE
PBLT2-20-60	20 (46.18) [14.08]	60 (18.3)	ETFE
PBLT2-5-40-PU	5 (11.54) [3.52]	40 (12.2)	Polyurethane
PBLT2-10-40-PU	10 (23.09) [7.04]	40 (12.2)	Polyurethane
PBLT2-15-60-PU	15 (34.63) [10.56]	60 (18.3)	Polyurethane
PBLT2-20-60-PU	20 (46.18) [14.08]	60 (18.3)	Polyurethane
PBLT2-3.5M-5M-PU	4.97 (11.48) [3.5]	16.40 (5)	Polyurethane
PBLT2-5M-10M-PU	7.10 (16.38) [5]	32.81 (10)	Polyurethane
PBLT2-10M-18M-PU	14.21 (32.78) [10]	59.06 (18)	Polyurethane

\*Configured ranges below 5 psi (11.54' w.c.) (3.52 m w.c.) ±1% FS accuracy  
 Note: For intrinsically safe approval, change model number from PBLT2 to PBLTX. For custom ranges or cable lengths, contact factory.

ACCESSORIES	
Model	Description
MTL5541	Galvanic barrier
MTL7706	Intrinsically safe zener barrier
A-297	Dessicant filter for vent tube. Removes humidity for protection of the sensor. Changes color to show saturation
A-625	316 SS cable hanger use with NPT option for attaching chain for easy pulling out of application



A-297

A-625

# FLUSH TIP SUBMERSIBLE LEVEL TRANSMITTERS

Perfect for Sludge and Slurries, Lightning Protected, ±0.25% Accuracy, Slim Body



FBLT



FBLT with NPT option

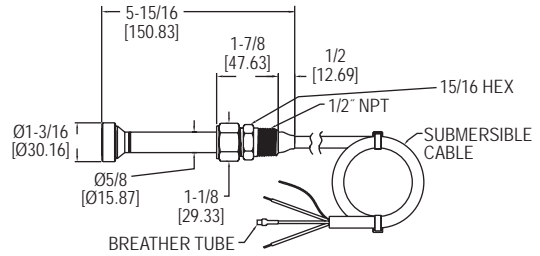
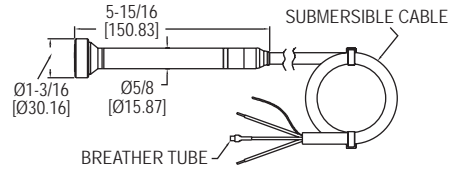

NPT option

The Series FBLT Flush Tip Submersible Level Transmitters measure the height of liquid above the position in the tank referenced to atmospheric pressure. The transmitter consists of a piezoresistive sensing element, encased in a narrow 316 SS housing with PTFE coated flush diaphragm tip.

**FEATURES/BENEFITS**

- Flush diaphragm tip will not clog in harsh applications
- Maintenance free filter eliminates particulate or water droplets from entering the transducer
- Comes with a choice of polyether polyurethane or ETFE cable materials for excellent chemical compatibility
- Incorporates lightning and surge protection, eliminating both power supply surges and lightning ground strike transients (surge protection is not guaranteed and is not covered by warranty)
- Narrow body design allows the FBLT to fit into stilling wells and narrow installations
- Robust FKM fluoroelastomer diaphragm that is PTFE coated for a stick resistant surface holds up in aggressive fluids
- Diaphragm cavity is filled with a gel that will not leak out versus oil or grease
- Optional NPT connection allows the unit to be rigidly installed in a pipe/conduit, or the addition of the A-625 hanging loop for attaching a chain for pulling out of the installation

**APPLICATIONS**

- Sewage lift stations
- Industrial slurries
- Industrial sumps
- Landfill leachate
- Reservoirs
- Sludge pits
- Oil tanks

MODEL CHART			
Model	Range psi (' w.c.) [m w.c.]	Cable Length	Cable Type
FBLT-2SC-IVPF-10-20*	4.33 (10) [3.05]	20'	Polyurethane
FBLT-2SC-IVPF-10-30*	4.33 (10) [3.05]	30'	Polyurethane
FBLT-2SC-IVPP-5-40	5 (11.54) [3.52]	40'	Polyurethane
FBLT-2SC-IVPF-10-40*	4.33 (10) [3.05]	40'	Polyurethane
FBLT-2SC-IVPF-15-40	6.50 (15) [4.57]	40'	Polyurethane
FBLT-2SC-IVPF-20-40	8.66 (20) [6.10]	40'	Polyurethane
FBLT-2SC-IVPF-30-50	12.99 (30) [9.14]	50'	Polyurethane
FBLT-2SC-IVPE-5-40	5 (11.54) [3.52]	40'	ETFE
FBLT-2SC-IVEF-15-40	2.82 (15) [4.57]	40'	ETFE
FBLT-2SC-IVEF-20-40	8.66 (20) [6.10]	40'	ETFE
FBLT-2SC-IVEF-30-50	12.99 (30) [9.14]	50'	ETFE
FBLT-2SC-IVPE-10-40	10 (32.09) [7.04]	40'	ETFE
FBLT-2SC-IVPE-15-60	15 (34.63) [10.56]	60'	ETFE
FBLT-2SC-IVPP-10-40	10 (32.09) [7.04]	40'	Polyurethane
FBLT-2SC-IVPP-10-60	10 (32.09) [7.04]	60'	Polyurethane
FBLT-2SC-IVPP-15-60	15 (34.63) [10.56]	60'	Polyurethane
FBLT-2SC-IVPF-35-60	15.16 (35) [10.67]	60'	Polyurethane
FBLT-2SC-IVPP-20-60	20 (196.85) [60]	60'	Polyurethane

\*4.3 to 4.9 psi (10 to 11.54 in w.c.) configured ranges ±0.30% FS accuracy  
**Note:** Cables can be ordered shorter or longer in polyurethane or ETFE. Other ranges are available and can be ordered in psi, ft w.c., or m w.c. Please see website.

SPECIFICATIONS	
<b>Service:</b>	Compatible liquids.
<b>Wetted Materials:</b>	Body: 316 SS; Cable: Polyether polyurethane or ETFE; Diaphragm: PTFE coated FKM fluoroelastomer; Label: Polyethylene polyamid.
<b>Accuracy:</b>	±0.25% FS (10' w.c. range is ±0.30% FS).
<b>Temperature Limits:</b>	-4 to 176°F (-20 to 80°C).
<b>Compensated Temperature Limits:</b>	32 to 140°F (0 to 60°C).
<b>Thermal Effect:</b>	±0.0075%/°F (±0.0135%/°C).
<b>Pressure Limit:</b>	2x range.
<b>Power Requirements:</b>	10 to 33 VDC.
<b>Output Signal:</b>	4 to 20 mA DC 2-wire.
<b>Response Time:</b>	< 50 ms.
<b>Max Loop Resistance:</b>	1000 Ω @ 30 VDC.
<b>Electrical Connections:</b>	Wire pigtail.
<b>Mounting Connection:</b>	Suspended below point being monitored.
<b>Electrical Protection:</b>	Surge/lightning protected per EN61000-4-5, Class 5.
<b>Weight:</b>	Body: 0.3 lb (0.136 kg); Cable: 0.037 lb (0.017 kg) per foot.
<b>Agency Approvals:</b>	CE.

OPTIONS	
To order add suffix:	Description
-NPT	1/2" NPT connection to connect conduit, piping, or cable hanger. All 316 SS
-FC	Factory calibration certificate
<b>Example:</b> FBLT-2SC-IVPF-20-40-FC	

ACCESSORIES	
Model	Description
A-297	Dessicant filter for vent tube. Removes humidity for protection of the sensor. Changes color to show saturation
A-625	316 SS cable hanger use with NPT option for attaching chain for easy pulling out of application



Level Transmitters, Submersible



SERIES CRF2 | MERCROID® BY DWYER

# CAPACITIVE LEVEL TRANSMITTER

Powder, Bulk or Liquids, No-Moving Parts, Excellent Chemical Resistance

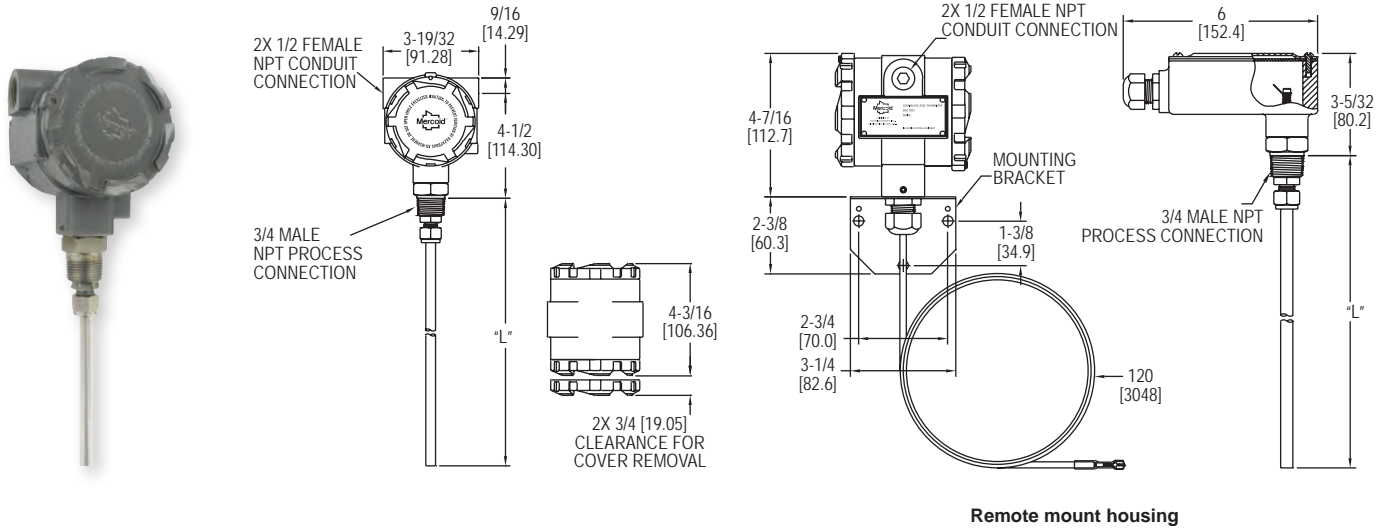

The **Series CRF2 Capacitive Level Transmitter** provides a two-wire 4 to 20 mA output to indicate level of liquids, powders and bulk materials. The CRF2 senses capacitance changes resulting from the height of the material in the tank between the probe and the tank wall. In non-metallic tanks or tanks that do not have the wall parallel to the probe a ground reference must be used.

**FEATURES/BENEFITS**

- State of the art sensing technology, uses impulse RF admittance measurement which provides excellent accuracy and stability
- Comes with either a rigid or flexible probe depending on application installation need and probe length required
- Easy push-button calibration of zero and span
- Any length probe can be customer ordered for any specific application
- FEP covered probe is ideal for use with corrosive media
- Immune to external RF sources like walkie-talkies and cell phones as well as minimal interference with radio communication or other electronic systems

**APPLICATIONS**

- Pulp and paper processing
- Chemical processing
- Food and beverage
- Aggregates
- Plastics
- Mining

**SPECIFICATIONS**

**Service:** Liquids, powders, and bulk materials compatible with wetted materials.  
**Wetted Materials:** Standard: Rod/cable: FEP, Connection: 316 SS; Ground option: Rod/cable and connection: 316 SS; Cable spacers: PVC; Flange option: Material of flange.  
**Capacitance Range:** 0 to 2000 pF.  
**Sensitivity:** 0.15 pF.  
**Minimum Span:** 8 pF.  
**Accuracy:** ±0.5 pF or ±0.25% of span, whichever is greater.  
**Repeatability:** ±0.25 pF or ±0.1% of span, whichever is greater.  
**Temperature Limits:** Ambient: -40 to 185°F (-40 to 85°C); Process: -40 to 250°F (-40 to 121°C).  
**Pressure Limit:** 100 psi (6.9 bar).  
**Power Requirements:** 12 to 35 VDC.  
**Output Signal:** 4 to 20 mA or 20 to 4 mA, 2 wire.  
**Response Time:** 0.5 s.  
**Electrical Connection:** Screw terminal.  
**Conduit Connection:** 1/2" NPT female.  
**Process Connection:** Standard: 3/4" NPT male; Optional: See model chart.  
**Enclosure Rating:** NEMA 4X (IP66) weather tight/corrosion resistant.  
**Spark/Static Protection:** 10<sup>6</sup> Ω dissipation resistance with spark gap. Surge current to 100 A max.  
**Calibration:** Zero, span, 4 mA, 20 mA.  
**Mounting Orientation:** Vertical.  
**Weight:** 6' rod type: 3.6 lb (1.63 kg).

**MODEL CHART**

Example	CRF2	-W	R	0	1T	-048	-M20	CRF2-WR01T-048-M20
<b>Series</b>	CRF2							Capacitive level transmitter
<b>Enclosure</b>		W						Weatherproof Remote mount weatherproof housing
<b>Probe Type</b>			R					Rod Cable
<b>Ground</b>				0				None included Attached ground rod (3" or 4" flange process connection types only) Unattached ground rod
<b>Process Connection</b>					1T			3/4" NPT male
					2T			1" NPT male
					3T			1-1/2" NPT male
					1B			3/4" BSPT
					2B			1" BSPT
					3B			1-1/2" BSPT
					1S			1" sanitary clamp
					2S			1-1/2" sanitary clamp
					3S			2" sanitary clamp
					1F			2" 150# flange, 316 SS
					2F			2" 150# flange, PVC
					3F			3" 150# flange, 316 SS
					4F			3" 150# flange, PVC
					5F			4" 150# flange, 316 SS
					6F			4" 150# flange, PVC
<b>Probe Length</b>					XXX			Insertion length in inches. Example 048 is 48" length. Rod type min: 24", max: 144"; Cable type min: 24", max: 360"
<b>Options</b>						M20		M20 conduit connection with cable gland
<b>Examples:</b> CRF2-WR01T-072; CRF2-WR01T-096								

Level Transmitters, Capacitive



# CONTINUOUS LEVEL TRANSMITTER

Customize To Fit Application, 316 SS or Buna-N Floats

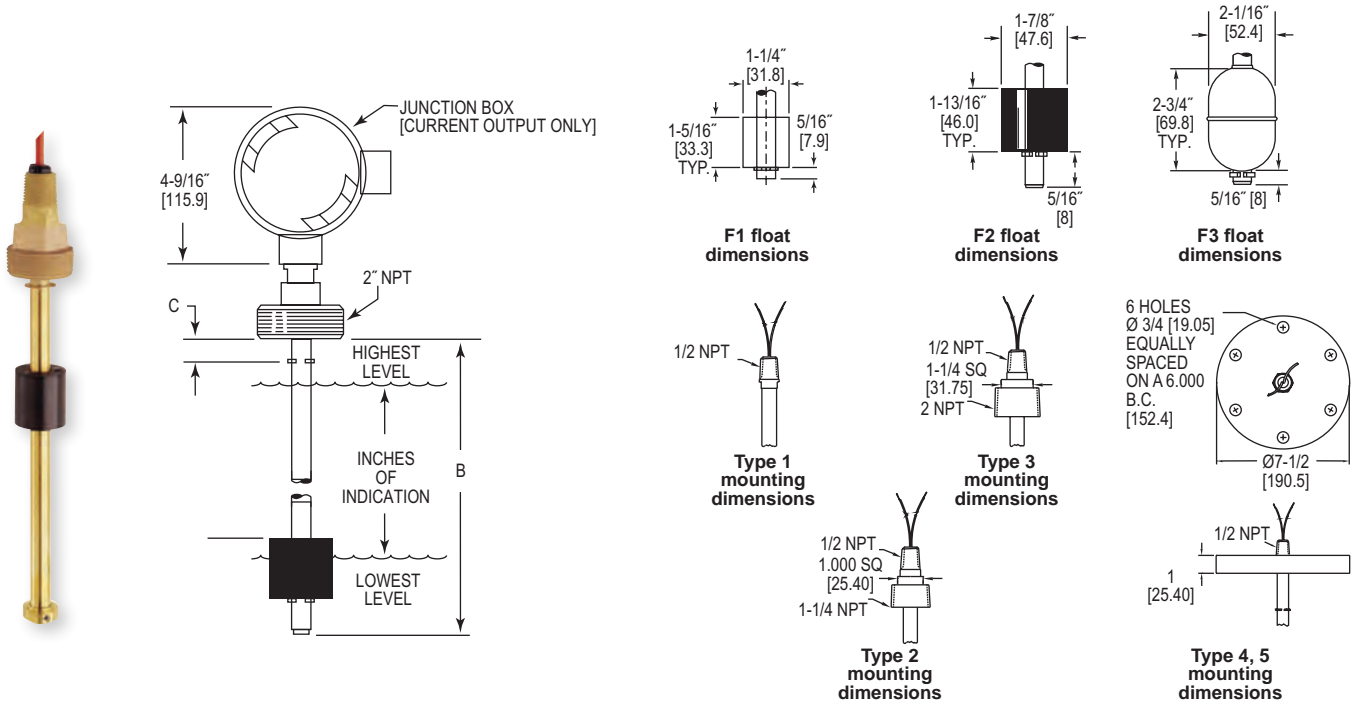

The **Series CLT Continuous Level Transmitter** provides up to the minute tank level monitoring with a customized level transmitter. Transmitters can be configured for 4-20 mA or proportional voltage output, 316 SS or Buna-N stem and floats, and lengths up to 72" (183 cm).

**FEATURES/BENEFITS**

- Customized stem length, actuation point, distance between floats, and lead wire lengths
- 4-20 mA or proportional voltage output outputs continuous level indication

**APPLICATIONS**

- General purpose level monitoring
- Low specific gravity applications
- Gas and oil

**SPECIFICATIONS**

**Service:** Compatible liquids.  
**Resolution:** 1/4" (6.35 mm).  
**Temperature Limits:** Buna-N floats: 180°F (82°C) in water, -40 to 230°F (-40 to 110°C) in oil; SS floats: -40 to 230°F (-40 to 110°C).  
**Pressure Limits:** Buna-N floats: 150 psig (10 bar); SS floats: 300 psig (21 bar).  
**Power Requirements:** Proportional voltage output models: 10-30 VDC; 4-20 mA output models: 10-40 VDC.  
**Loop Resistance:** 1.4k Ω max.  
**Electrical Connections:** Proportional voltage output: 24" (61 cm) free leads #22 AWG, TFE jacketed; 4-20 mA output: Junction box.  
**Enclosure Rating:** 4-20 mA models, NEMA 4 (IP56) junction box.  
**Mounting Orientation:** Vertical ±20°.

MODEL CHART																									
Example	CLT	-V	S	5	F3	-20.25	-02.00	-25.75	CLT-VS5F3-20.25-02.00-25.75																
Construction	CLT								Continuous level transmitter																
Output		V	C						Voltage, proportional signal of 0 to supply voltage 4-20 mA (junction box provided)																
Stem & Connection Material			B	S					Brass with beryllium copper stops 316 SS with SS ARMCO PH-15-7MO stops																
Connection Type				1	2	3	4	5	1/2" NPT (output type V only) 1-1/4" NPT (float F1 only) 2" NPT 3" 150# flange, carbon steel (connection material S only) [max. pres. 150 psi (10.3 bar)] 3" 150# flange, 316 SS (connection material S only) [max. pres. 150 psi (10.3 bar)]																
Float Type					F1	F2	F3		<table border="1"> <thead> <tr> <th>Material</th> <th>Min. s.g.</th> <th>Max. Pressure</th> <th>Float Factor</th> </tr> </thead> <tbody> <tr> <td>Buna-N</td> <td>0.55</td> <td>150 psi (10.3 bar)</td> <td>2.0" (50.8 mm)</td> </tr> <tr> <td>Buna-N</td> <td>0.55</td> <td>150 psi (10.3 bar)</td> <td>2.5" (63.5 mm)</td> </tr> <tr> <td>316 SS</td> <td>0.75</td> <td>300 psi (20.7 bar)</td> <td>3.5" (52.4 mm)</td> </tr> </tbody> </table>	Material	Min. s.g.	Max. Pressure	Float Factor	Buna-N	0.55	150 psi (10.3 bar)	2.0" (50.8 mm)	Buna-N	0.55	150 psi (10.3 bar)	2.5" (63.5 mm)	316 SS	0.75	300 psi (20.7 bar)	3.5" (52.4 mm)
Material	Min. s.g.	Max. Pressure	Float Factor																						
Buna-N	0.55	150 psi (10.3 bar)	2.0" (50.8 mm)																						
Buna-N	0.55	150 psi (10.3 bar)	2.5" (63.5 mm)																						
316 SS	0.75	300 psi (20.7 bar)	3.5" (52.4 mm)																						
Indication Length					00.00				Length that the unit sends an output for level, maximum is 68" (173 cm)																
Top Float Stop "C" Dimension Overall						00.00			Distance from bottom of mounting connection to upper float stop, minimum is 1/4" (6.4 mm)																
Length "B"							00.00		To calculate overall length, add indication length, top float, stop dimension "C", and float factor, maximum length is 72" (1.82 m)																
<b>Note:</b> Models are built to your specifications																									

# ULTRASONIC LEVEL TRANSMITTER

Explosion-Proof, Mapping Software, 3" (76.2 mm) Measuring Column

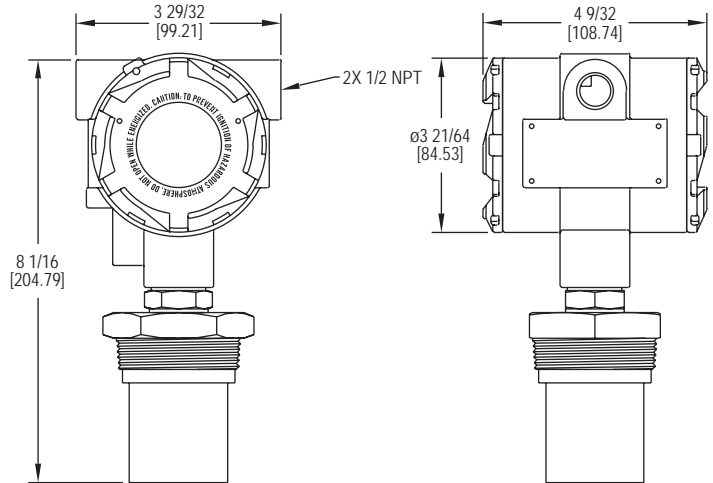

The **Series ULT Ultrasonic Level Transmitter** provides non-contact measurement of liquid levels in an explosion-proof body. It is capable of measuring up to 32.8' (10 m) with a PVDF sensor and 4 to 20 mA output.

## FEATURES/BENEFITS

- Provides reliable, accurate, and non-contact level measurement of compatible liquids
- Non-contact technology offers no moving parts to wear, jam, corrode, or get coated like contact technologies
- Mapping software makes effective measuring surface only a 3" (76.2 mm) diameter column with no concerns of ladders, pipes, or other tank intrusions in the remaining sound cone
- FM approved explosion-proof making it ideal for use in hazardous locations
- Easy programming with 6 digit LCD display and simple menu structure
- Output range is adjustable with choices of inputting tank dimensions or by filling and emptying the tank while calibrating and it automatically and scaling to levels it senses
- Window cover allows easy viewing of display
- Fail-safe output options and diagnostic capabilities

## APPLICATIONS

- Water and wastewater
- Pulp and paper processing
- Chemical processing
- Food and beverage

## MODEL CHART

Model	Range
ULT-11	24.6' (7.5 m)
ULT-21	32.8' (10 m)

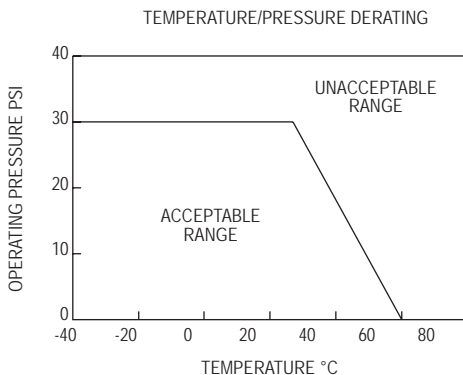

## SPECIFICATIONS

**Service:** Compatible fluids. Not for use with powder and bulk solids.  
**Wetted Materials:** Sensor: PVDF; Process connection: 303 SS; O-ring: Fluoroelastomer.  
**Ranges:** 24.6' (7.5 m), 32.8' (10 m).  
**Accuracy:** ±0.2% FS.  
**Resolution:** 0.079" (2 mm).  
**Blind Zone:** Under 8" (20 cm).  
**Beam Width:** 3" (7.6 cm) diameter.  
**Temperature Limits:** Ambient: -40 to 140°F (-40 to 60°C); Process: -4 to 140°F (-20 to 60°C).  
**Temperature Compensation:** -40 to 140°F (-40 to 60°C).  
**Pressure Limits:** 30 psi (2 bar) up to 25°C (77°C). Above 25°C (77°F), rating decreases 1.667 psi per 1°C increase. See chart.  
**Power Requirement:** 18-28 VDC (two-wire).  
**Output Signal:** 4-20 mA or 20-4 mA (two-wire).  
**Max. Loop Resistance:** 250 Ω at 24 VDC.  
**Electrical Connections:** Screw terminal.  
**Conduit Connection:** 1/2" NPT female (two) or optional M20.  
**Process Connection:** 2" NPT male or optional BSPT.  
**Enclosure Rating:** Weather-proof meets NEMA 4X (IP66), explosion-proof rated Class I, Div. 1, Groups B, C, D; Class II/III, Div. 1, Groups E, F, G.  
**Mounting Orientation:** Vertical.  
**Failsafe:** On lost echo after 30 seconds, user selectable to 4, 20, 21, 22 mA or last signal.  
**Memory:** Non-volatile.  
**Display:** 6 character LCD.  
**Units:** In, cm, ft, m, percent.  
**Programming:** 4 button.  
**Weight:** 4.0 lb (1.8 kg).  
**Agency Approvals:** CE, FM.

# ULTRASONIC LEVEL SENSORS

Non-Contact Transmitter, SPST Programmable Relays

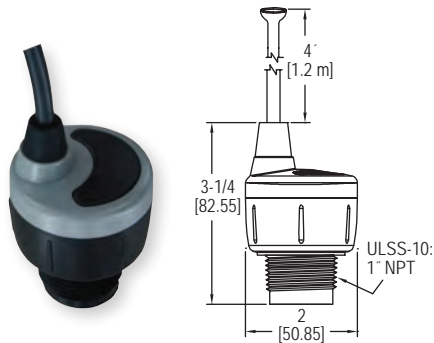

ULSS

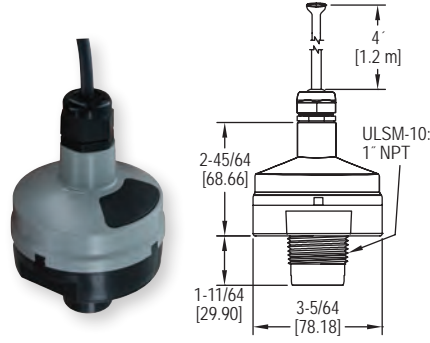

ULSM

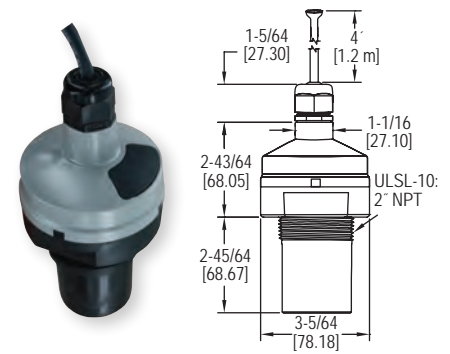

ULSL



The **Series ULSS Ultrasonic Level Sensor** provides non-contact, continuous ultrasonic level measurement of fluids for short range applications. It has a 4.1' (1.2 m) measuring range with a 0.125" (3 mm) accuracy.

The **Series ULSM Ultrasonic Level Sensor** provides non-contact, continuous ultrasonic level measurement of fluids for medium range applications. It has a 9.8' (3 m) measuring range with a ±0.2% of range accuracy.

The **Series ULSL Ultrasonic Level Sensor** provides non-contact, continuous ultrasonic level measurement of fluids for tall range applications. It has a 18' (5.5 m) measuring range with a ±0.2% of range accuracy.

**FEATURES/BENEFITS**

- Via free software, units can be programmed to transmit an output signal and operate four relays for control applications
- Provides reliable, accurate, and non-contact level measurement of compatible liquids
- Non-contact technology offers no moving parts to wear, jam, corrode, or get coated like contact technologies
- Mapping software makes effective measuring surface only a 3" (76.2 mm) diameter column with no concerns of ladders, pipes, or other tank intrusions in the remaining sound cone
- Ultrasonic technology paired with automatic temperature compensation provides accurate and reliable measurements in almost all conditions
- Fail-safe logic is easily configured to custom applications via free software removing the need for target calibration
- Full NEMA 6P submersible enclosure rating to ensure excellent product durability

**APPLICATIONS**

- Water and wastewater
- Pulp and paper processing
- Sump and process tanks
- Chemical processing
- Food and beverage

MODEL CHART	
Model	Range
ULSS-10	4.1' (1.25 m)
ULSM-10	9.8' (3 m)
ULSL-10	18' (5.5 m)

**Note:** USB adapter necessary for calibration. One adapter can program multiple units.

**SPECIFICATIONS**

**Service:** Compatible fluids.  
**Wetted Materials:** Sensor: PVDF; O-ring: FKM.  
**Ranges:** See chart.  
**Accuracy:** ULSS: 0.125" (3 mm); ULSM & ULSL: ±0.2% of range.  
**Resolution:** ULSS: 0.019" (0.5 mm); ULSM: 0.039" (1 mm); ULSL: 0.079" (2 mm).  
**Blind Zone:** ULSS: 2" (5 cm); ULSM: 4" (10 cm); ULSL: 8" (20 cm).  
**Beam Width:** ULSS & ULSM: 2" (5 cm); ULSL: 3" (7.62 cm).  
**Temperature Limits:** Process: 20 to 140°F (-7 to 60°C); Ambient: -31 to 140°F (-35 to 60°C).  
**Temperature Compensation:** Automatic.  
**Pressure Limit:** 30 psi (2 bar).  
**Power Requirement:** 12 to 28 VDC.  
**Output Signal:** 4-20 mA, 2-wire; Invert: 4-20 mA or 20-4 mA; Fail-safe: 4 mA, 20 mA, 21 mA, 22 mA, or hold last.  
**Loop Resistance:** 400 Ω max.  
**Electrical Connections:** 4' (1.2 m) 9 conductor shielded cable.  
**Contact Type:** 4 SPST relays.  
**Contact Rating:** 1 A max @ 28 VDC max.  
**Deadband:** Selectable (no hysteresis, 1/4", 1/2", 1", 1/2 cm, 1 cm, 2 cm, 5 cm or not available).  
**Process Connection:** 1" NPT, 1" BSPP (optional).  
**Enclosure Rating:** NEMA 6P (IP68).  
**Enclosure Material:** Polycarbonate; Gland: TPE.  
**Mounting Orientation:** Vertical.  
**Memory:** Non-volatile.  
**Failsafe:** Contact: Power loss: Holds last contact; Power on: Open, close, or last contact.  
**Programming:** Free PC software download (USB adapter required).  
**Weight:** 1 lb (0.45 kg).  
**Agency Approvals:** CE.

ACCESSORIES	
Model	Description
ULS-ACC-USB	USB adapter for calibration, PVC
ULS-ACC-121	2" x 1" NPT reducer bushing fitting (sch. 40), PVC
ULS-ACC-122	2" x 1" NPT reducer bushing fitting (sch. 80), PVC
ULS-ACC-131	3" x 2" NPT reducer bushing fitting (sch. 40), PVC
ULS-ACC-132	3" x 2" NPT reducer bushing fitting (sch. 80), PVC
ULS-ACC-142	4" x 2" NPT reducer bushing fitting (sch. 80), PVC
ULS-ACC-221	2" socket x 1" NPT reducer bushing fitting (sch. 40), PVC
ULS-ACC-222	2" socket x 1" NPT reducer bushing fitting (sch. 80), PVC
ULS-ACC-231	3" socket x 2" NPT reducer bushing fitting (sch. 40), PVC
ULS-ACC-232	3" socket x 2" NPT reducer bushing fitting (sch. 80), PVC
ULS-ACC-241	4" socket x 2" NPT reducer bushing fitting (sch. 40), PVC
ULS-ACC-242	4" socket x 2" NPT reducer bushing fitting (sch. 80), PVC
ULS-ACC-510	1" NPT polypropylene side mount bracket
ULS-ACC-520	2" NPT polypropylene side mount bracket

# PUMP CONTROLLER

One or Two Pump Control with Built-In Alternation, Over Temperature Protection and Seal Failure Monitoring

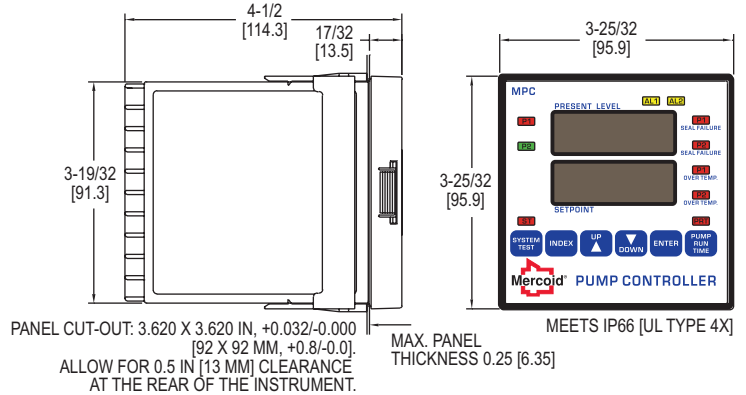

The **Series MPC Pump Controller** provides versatile level control in a standard 1/4 DIN package. Designed for use with almost any style level transmitter the unit displays the present level and main set point value. Incorporated in the MPC is programmable level differential for on/off control of one or two pumps, valves, or other devices through two SPDT relays.

## FEATURES/BENEFITS

- Selectable pump alternation when used with two pumps to minimize pump wear, with alternation "on" a seal failure or over temperature condition will force the non-failed pump to lead status and stop alternation
- Alarms can be programmed for output indication of pump seal failure or over temperature
- Selectable time delay, for pump two, on power up to prevent both pumps from starting at the same time
- In the event of power loss, upon regaining power a time delay of up to 60 seconds can be selected to prevent excessively large current draw
- Integral 24 VDC power supply to power level transmitter
- Displays pump run time from a front panel button
- Test system function simulates the process input to ensure the pumps are operating or to test programming
- User selectable security lock-out of programming and/or set points
- Process input retransmission as a current (4 to 20 mA) or voltage (2 to 10 VDC) analog signal (standard model MPC is set for current retransmission. For voltage retransmission add suffix "-RV")
- Two additional programmable alarm contacts with front alarm light indication
- Front panel face meets NEMA 4X for outdoor panel mounting
- User-friendly programming menu

## APPLICATIONS

- Water and wastewater
- Sump and sludge pits, clarifiers, digesters
- Chemical storage tanks
- Oil tanks
- Reservoirs

## SPECIFICATIONS

**Inputs:** 4 (or 0)-20 mA DC or 2 (or 0)-10 VDC selectable.  
**Input Impedance:** Current = 10 Ω; Voltage = 100 K Ω.  
**Output Ratings:** Control relays: SPDT, rated 10 A @ 240 VAC res., 1/4 hp @ 120 VAC, 1/3 hp @ 240 VAC; Alarm relays: SPST, 3 A @ 240 VAC res., 1/10 hp @ 120 VAC.  
**Control Type:** On/off, reverse (pump out) or direct (pump in) acting.  
**Power Requirements:** 100-240 VAC nominal, +10%-15%, 50 to 400 Hz, single phase; 132 to 240 VDC nominal, +10%-15%.  
**Power Consumption:** 7.5 VA max.  
**Accuracy:** ±0.25% of span, ±1 least significant digit.  
**Display:** Two 4 digit, 7 segment 0.56" high LED's.  
**Display Resolution:** 1 count.  
**Memory Backup:** Nonvolatile memory (no batteries required).  
**Serial Communications:** Optional RS-232 or RS-485 with Modbus® protocol.  
**Ambient Operating Temperature/RH:** 14 to 131°F (-10 to 55°C)/0 to 90% up to 104°F (40°C) non-condensing, 10 to 50% at 131°F (55°C) non-condensing.  
**Front Panel Rating:** Meets UL Type 4X (IP66).  
**Loop Power Supply (Isolated):** 24 VDC @ 50 mA, regulated.  
**Seal Failure (Moisture Sensor):** Power: 2.5 VDC; Search current: 3 micro amps; Resolution: 10K to 500K Ω in 10K Ω steps.  
**Weight:** 16 oz (454 g).  
**Agency Approvals:** cULus.

## MODEL CHART

Model	Description
MPC	Pump controller

## OPTIONS

To order add suffix:	Description
-232	RS-232 Modbus® RTU serial communications
-485	RS-485 Modbus® RTU serial communications

## ACCESSORIES

Weatherproof Enclosures, NEMA 4X (IP66).<sup>Ⓞ</sup>



A-901

Modbus® is a registered trademark of Schneider Automation, Inc.

Compatible Level Transmitters: See page 328 (Series SBLT2)  
See page 330 (Series PBLT2)

Additional Digital Control Panel Meters: See page 338 (Series APM/MPM/PPM)  
Ⓞ See page 338 (Series A-900 & A-901)



# PUMP CONTROLLER

One or Two Pump Control with Built-In Alternation

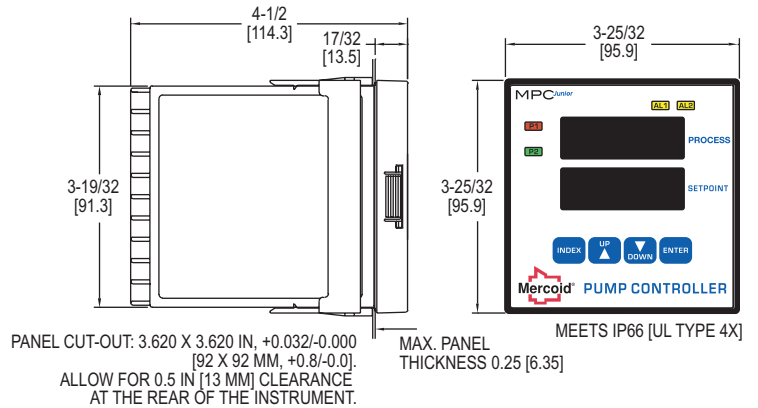

The **Series MPC JR Pump Controller** provides versatile level control in a standard 1/4 DIN package. Designed for use with almost any style level transmitter the unit displays the present level and main set point value. Incorporated in the MPC JR is programmable level differential for on/off control of one or two pumps, valves, or other devices through two SPDT relays.

**FEATURES/BENEFITS**

- Selectable pump alternation when used with two pumps to minimize pump wear
- Integral 24 VDC power supply for transmitter
- User selectable security lock-out of programming and/or set points
- Optional process input retransmission as a current (4-20 mA) or voltage (2-10 VDC) analog signal
- Analog output on pump "on" condition for activation of separate pump run time meters

**APPLICATIONS**

- Water and wastewater
- Sump and sludge pits, clarifiers, digesters
- Chemical storage tanks
- Oil tanks
- Reservoirs

**SPECIFICATIONS**

**Inputs:** 4 (or 0)-20 mA DC or 2 (or 0)-10 VDC selectable.  
**Input Impedance:** Current = 10 Ω; Voltage = 5 K Ω.  
**Output Ratings:** Control relays: SPDT, rated 10 A @ 240 VAC res., 1/4 hp @ 120 VAC, 1/3 hp @ 240 VAC; Alarm relays: SPST, 3 A @ 240 VAC res., 1/10 hp @ 120 VAC; Others: 15 VDC @ 20 mA for output one and output two.  
**Control Type:** On/off, reverse (pump out) or direct (pump in) acting.  
**Power Requirements:** 100-240 VAC nominal, +10%-15%, 50 to 400 Hz, single phase; 132-240 VDC nominal, +10%-15%.  
**Power Consumption:** 7.5 VA max.  
**Accuracy:** ±0.25% of span, ±1 least significant digit.  
**Display:** Two 4-digit, 7 segment 0.56" high LED's.  
**Display Resolution:** 1 count.  
**Memory Backup:** Nonvolatile memory (no batteries required).  
**Serial Communications:** Optional RS-232 or RS-485 with Modbus® protocol.  
**Ambient Operating Temperature/RH:** 14 to 131°F (-10 to 55°C)/0 to 90% up to 104°F (40°C) non-condensing, 10 to 50% at 131°F (55°C) non-condensing.  
**Front Panel Rating:** Meets UL Type 4X (IP66).  
**Loop Power Supply (Isolated):** 24 VDC @ 50 mA, regulated.  
**Weight:** 16 oz (454 g).  
**Agency Approvals:** cULus.

MODEL CHART	
Model	Description
MPCJR	Pump controller

OPTIONS	
To order add suffix:	Description
-RC	Retransmission of input, 4-20 mA
-RV	Retransmission of input, 0-10 VDC
-232	RS-232 Modbus® RTU serial communications
-485	RS-485 Modbus® RTU serial communications

ACCESSORIES	
Weatherproof Enclosures, NEMA 4X (IP66). ①	



A-901

Modbus® is a registered trademark of Schneider Automation, Inc.

Compatible Level Transmitters: See page 328 (Series SBLT2)  
See page 330 (Series PBLT2)  
① See page 338 (Series A-900 & A-901)



SERIES APM, MPM & PPM

# PANEL METERS & PUMP CONTROLLERS

Open Channel Flow, Rate and Total, Multi-Pump Control



APM



MPM



PPM

The **Series APM Panel Meter** is a 1/8 DIN digital panel meter perfect for displaying flow rate and total simultaneously from several analog inputs such as a 4-20 mA or 0-10 V from any flow transmitter. When utilized with an ultrasonic level transmitter, such as the Mercoïd Series ULT, this series provides an economical way to measure open channel flow. The dual line display can be configured to read flow rate, total, grand total, as well as engineering units.

The **Series MPM Pump Controller** is also a 1/8 DIN digital panel meter but for multi-pump alternation control. This series features, non-latching, sampling, and fail-safe action in addition to its ability to alternate up to four pumps. This series is also capable of linearizing nonlinear inputs with a variety of pre-programmed math functions. This is helpful in applications where volume is monitored in odd shaped tanks as well as open channel flow monitoring. It accepts 0-20 mA, 4-20 mA, 0-5 V, 1-5 V or 0±10 V standard.

The **Series PPM Panel Meter** is a 1/8 DIN digital panel meter specifically designed for a variety of pulse inputs. This series is particularly well-suited for flow applications with its large six-digit, dual-line display that can display flow rate and total simultaneously with up to 4 programmable relay options and 4-20 mA output. This series features latching, non-latching, sampling, and fail-safe action in addition to its pump alternation function.

For more information on these products: See page 352

## MODEL A-900 & A-901 | MERCOÏD® BY DWYER

# 1/4 DIN CONTROL ENCLOSURES

Weatherproof, Durable, Pre-Cut Mounting Hole



Level/Pump Controllers



A-900



A-901

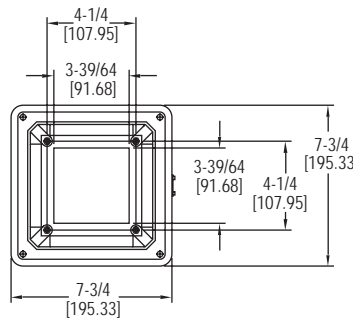

Top view

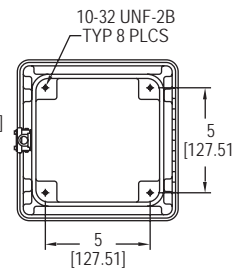

Bottom view

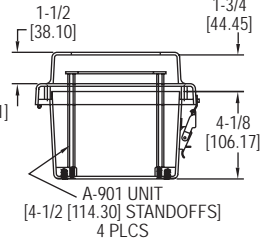

Side view

The **Model A-900 & A-901 1/4 DIN Control Enclosures** are rated weatherproof type NEMA 4X to protect controls from dirt, dust, oil, and water. The Model A-900 comes with a standard 1/4 DIN cutout in the front cover and the Model A-901 comes with a clear plastic front window. Both units feature a lockable latch to prevent unauthorized removal of the control from the enclosure.

### FEATURES/BENEFITS

- UV stabilized for outdoor use
- Fiberglass material is easily punched or drilled for conduit connections
- Compatible with Love Series 2500, 2600, 4B, 4C, 4G, and Mercoïd Series MPC, MPCJR

### APPLICATIONS

- Wastewater remote pump stations
- Outdoor industrial ovens/furnaces/boilers

### SPECIFICATIONS

**Service:** Indoor or outdoor.  
**Rating:** NEMA 1, 2, 3, 3R, 4, 4X, 12 and 13.  
**Materials:** Body: UV stabilized fiberglass reinforced polyester; Snap latch: 304 SS; Hinge: SS; Mounting feet and screws: 304 SS; Window: UV stabilized polycarbonate; Cover gasket: Neoprene.  
**Enclosure Rating:** NEMA 4X (IP66).  
**Control Temperature Limits:** When using the enclosures with controls that have 10 A relay outputs the extra heat generation decreases the maximum ambient temperature value that the control can be used at inside the enclosure. Other outputs on our controls are not a concern.  
**Agency Approvals:** UL.

### MODEL CHART

Model	Description
A-900	Weatherproof enclosure, NEMA 4X, control direct panel mounts in the front of the enclosure
A-901	Weatherproof enclosure, NEMA 4X, clear plastic window with rear panel for mounting the control inside the enclosure

### ACCESSORIES

Model	Description
A-600	R/C snubber

FOR MODELS: 25XX3, 26XX3, 26X3X, 26X33, MPC, MPCJR		
Ambient Temperature	A-900 Maximum Current	A-901 Maximum Current
77°F (25°C)	10 amps	10 amps
104°F (40°C)	10 amps	9 amps
131°F (55°C)	7.5 amps	6 amps

# BIN AERATOR PADS

Inexpensive, Quiet Operation

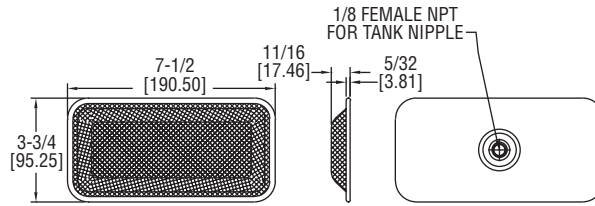

BAP aerator

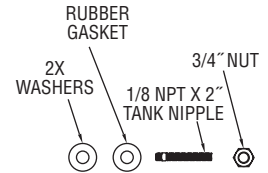

Mounting hardware

The **Series BAP Bin Aerator Pads** provide positive flow of dry, finely ground materials from any bin using the proven principle of aeration. It features simple and quick installation, is inexpensive, and adapts to any bin configuration.

**FEATURES/BENEFITS**

- Provides positive, uniform, and easily controlled flow with quiet operation
- Non-clogging

**APPLICATIONS**

- Powder and bulk

**SPECIFICATIONS**

**Temperature Limit:** BAP-C and BAP-SSC: 180°F (82°C) BAP-F and BAP-SSF: 600°F (316°C).  
**Supply Pressure:** 3 to 5 psi (0.2 to 0.3 bar).  
**Air Consumption:** See chart.  
**Air Connection:** 1/8" NPT male.  
**Materials:** See model chart.

MODEL CHART	
Model	Description
BAP-C	Zinc plated steel with gal. steel mesh & cotton diffuser
BAP-SSC	316 SS with 316 SS mesh & cotton diffuser
BAP-F	Zinc plated steel with gal. steel mesh & fiberglass diffuser
BAP-SSF	316 SS with 316 SS mesh & fiberglass diffuser
BAP-K	Optional external mounting kit

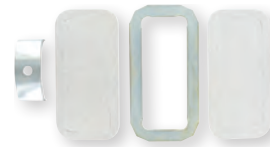

BAP-K

AIR CONSUMPTION GUIDE	
1 psi (0.07 bar)	4.2 CFM (118.9 LPM)
2 psi (0.14 bar)	5.7 CFM (161.4 LPM)
3 psi (0.21 bar)*	6.5 CFM (184.1 LPM)
4 psi (0.28 bar)	7.1 CFM (201.0 LPM)
5 psi (0.34 bar)	7.6 CFM (215.2 LPM)

\*Recommended for most applications

# PISTON VIBRATOR

Air Cushioned or Piston Vibrators

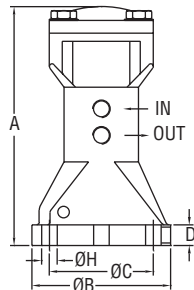

Model	A	B	C	D	H	IN/OUT
APV-X1	5-7/16 [138.11]	3-5/32 [80.17]	2-3/8 [60.33]	31/64 [12.30]	23/64 [9.13]	1/8 BSPT
APV-X2	6-35/64 [166.69]	3-15/16 [100.01]	2-61/64 [75.01]	41/64 [16.27]	7/16 [11.11]	1/4 BSPT
APV-X3	8-13/64 [208.36]	5-33/64 [140.10]	4-9/64 [105.17]	41/64 [16.27]	19/32 [15.08]	1/4 BSPT

The **Series APV Piston Vibrator** uses compressed air to push the piston from one side and cause vibration power. APV-C models are air cushioned to provide low noise, making it suitable for quiet area applications. APV-I models allow direct impact on the tank to help get rid of dust or material accumulated inside of pipes and tanks.

**FEATURES/BENEFITS**

- High strength aluminum alloy housing
- Frequency and amplitude of vibration can be adjusted as needed
- Low frequency and direct impact models available

**APPLICATIONS**

- Bin vents
- Bag houses
- Dust collectors

**SPECIFICATIONS**

**Temperature Limit:** 212°F (100°C).  
**Noise Level Range:** APV-C: 60-75 dBA; APV-I: 80-115 dBA.  
**Supply Pressure:** 29 to 87 psi (2 to 6 bar).  
**Air Consumption:** See model chart.  
**Air Connection:** 1/8" BSPT female with 1/4" OD push to connect adapter on APV-C1 and APV-I1; 1/4" BSPT female with 1/4" OD push to connect adapter on APV-C2, APV-C3, APV-I2 and APV-I3. Also includes muffler for exhaust port.  
**Housing Material:** Aluminum.

**HOW THEY OPERATE**

There are air-breathing tubes located in both ends of the cylinder. Compressed air pushes the piston from one side to the other. Vibration power arises when the piston moves back and forth in the body. In APV-C air cushion at both ends produced by the to-and-fro motion will keep the piston from striking the body. Therefore, the piston will not produce much noise. In APV-I, air cushion at the top end is produced by the to-and-fro compression. This will keep the piston from striking onto the body top. The piston will strike directly on the bottom side of the body to produce a strong impact.

Model	Frequency (V.P.M.) Pressure Input			Force lbf (N) Pressure Input			Air Consumption cfm (l/min) Pressure Input	Weight lb (kg)
	29 psi (2 bar)	58 psi (4 bar)	87 psi (6 bar)	29 psi (2 bar)	58 psi (4 bar)	87 psi (6 bar)		
APV-C1	1765	2308	2857	44 (195)	85 (380)	126 (560)	8.12 (230)	1.98 (0.9)
APV-C2	1333	1677	1875	62 (275)	119 (531)	161 (715)	8.79 (249)	4.19 (1.9)
APV-C3	1000	1200	1340	91 (404)	175 (780)	231 (1030)	9.50 (269)	9.92 (4.5)
APV-I1	1973	2885	3571	1818 (8086)	3044 (13542)	3996 (17776)	8.8 (250)	2.2 (1.0)
APV-I2	1744	2459	3000	3245 (14443)	4934 (21948)	6048 (26904)	9.5 (270)	4.6 (2.1)
APV-I3	1277	1875	1973	3470 (15434)	7799 (34692)	8276 (36816)	10.6 (300)	10.6 (4.8)

V.P.M. = vibrations per minute

**Dwyer**

SERIES IPV | PROXIMITY® BY DWYER

# AIR HAMMER

## Single Impacting Type

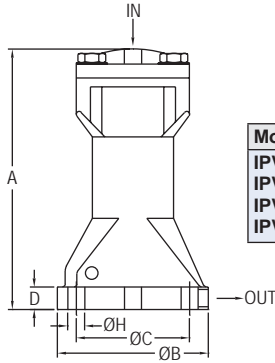

Model	A	B	C	D	H	IN/OUT
IPV-1	5-7/16 [138.11]	3-5/32 [80.17]	2-3/8 [60.33]	31/64 [12.30]	23/64 [9.13]	1/4 BSPT
IPV-2	6-35/64 [166.69]	3-15/16 [100.01]	2-61/64 [75.01]	41/64 [16.27]	7/16 [11.11]	1/4 BSPT
IPV-3	8-13/64 [208.36]	5-33/64 [140.10]	4-9/64 [105.17]	41/64 [16.27]	19/32 [15.08]	1/4 BSPT
IPV-4	10-19/32 [269.08]	6-25/32 [172.24]	5-33/64 [140.10]	61/64 [24.21]	3/4 [19.05]	3/8 BSPT

The Series IPV Air Hammer helps to smooth the flow and prevent accumulation inside of containers. It is often applied to a pipe or clean elbow in a tank filled with humidity or low specific gravity material.

**FEATURES/BENEFITS**

- High strength aluminum housing
- Impact force and interval timing can be adjusted as needed
- Magnetic hammer stores magnetic strength to increase the piston's impact power
- Includes muffler for exhaust port.

**APPLICATIONS**

- Bin vents
- Bag houses
- Dust collectors

**HOW IT OPERATES**

The IPV series air hammer contains a powerful magnet inside the hammer. The hammer and magnet are tightly closed before activation. As the inlet air pressure gets higher than the force, this tightens the hammer and magnet. The hammer and magnet will separate and cause more strength for impact power. The spring will bring the hammer back to the initial position automatically after the impact. By doing this, the air pressure will be released and the strength of the air pressure will be delivered to the target impact container. It will help to smooth the flow and prevent accumulation inside the container.

**SPECIFICATIONS**

**Temperature Limit:** 212°F (100°C).  
**Noise Level Range:** 60 to 75 dBA.  
**Supply Pressure:** 43.5 to 87 psi (3 to 6 bar).  
**Air Consumption:** See model chart.  
**Air Connection:** 1/4" BSPT female with 1/4" OD push to connect adapter on IPV-1, IPV-2 and IPV-3; 3/8" BSPT female with 3/8" OD push to connect adapter on IPV-4.

**MODEL CHART**

Model	Impulse lb•s (N•S)	Air Consumption in <sup>3</sup> (l) per stroke	Weight lb (kg)
IPV-1	.225 (1.0)	1.71 (0.028)	2.43 (1.1)
IPV-2	.630 (2.8)	5.0 (0.082)	3.97 (1.8)
IPV-3	1.66 (7.4)	14.0 (0.228)	8.82 (4.0)
IPV-4	2.81 (12.5)	27.8 (0.455)	18.52 (8.4)

SERIES EBV | PROXIMITY® BY DWYER

# ELECTRIC BIN VIBRATOR

## Adjustable Vibration Intensity

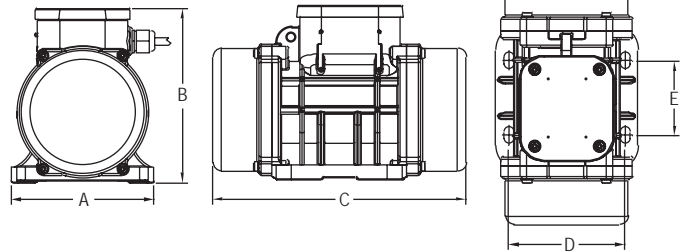
**DIMENSIONS - IN (MM)**

Model	A	B	C	D	E
EBV-1	5-1/8 (130)	5-23/64 (136)	8-5/16 (211)	4-11/64 (106)	2-43/64 (68)
EBV-2	5-1/8 (130)	5-23/64 (136)	8-5/16 (211)	4-11/64 (106)	2-43/64 (68)
EBV-3	5-1/8 (130)	6-17/64 (159)	9-3/32 (231)	4-11/64 (106)	2-43/64 (68)
EBV-4	6-7/64 (155)	6-23/32 (170)	10-23/64 (263)	4-7/16 (113)	5-1/8 (130)

The Series EBV Electric Bin Vibrator features an adjustable force, which increases the application flexibility and reduces equipment downtime and labor expense. The low amperage draw at 120 V reduces power consumption and makes the vibrators usable in any application. The EBV is capable of running continuously at 100% force output without overheating or mechanical damage.

**FEATURES/BENEFITS**

- NEMA 4X (IP66) aluminum housing
- Centrifugal force can be adjusted as needed
- Silent operation at 20 dB

**APPLICATIONS**

- Bin vents
- Bag houses
- Dust collectors

**SPECIFICATIONS**

**Power Requirements:** 120 VAC.  
**Power Consumption:** See model chart.  
**Temperature Limits:** -4 to 104°F (-20 to 40°C).  
**Enclosure:** Aluminum.  
**Enclosure Rating:** NEMA 4X (IP66).  
**Noise Level:** 20 dB.  
**Electrical Connection:** Electrical junction box.  
**Rotational Speed:** 3600 RPM.  
**Weight:** See model chart.  
**Agency Approvals:** CE.

**MODEL CHART**

Model	Max Power		Centrifugal Force		Current Max Amps	Weight lb
	Kw	Hp	Kg	lb		
EBV-1	0.09	0.12	71	156.5	1.03	9.3
EBV-2	0.11	0.15	95	209.4	1.3	10.1
EBV-3	0.21	0.28	189	416.7	2.62	15.4
EBV-4	0.28	0.38	323	712.1	3.43	21.6



**SELECTION GUIDE**  
pages 342-345

**TYPICAL APPLICATIONS**  
pages 346-347

  
**Panel Meters/Indicators**  
pages 348-353

  
**Annunciators/ Alarm Modules**  
page 354

  
**Relays**  
pages 355-356

  
**Current Transformers/ Switches**  
pages 356-359

  
**Power Transformers**  
page 360

  
**Signal Converters**  
page 361

  
**Power Supplies**  
pages 361-362

  
**Fan Speed Controls**  
page 363

  
**Vibration Controls**  
page 363

  
**Timers**  
page 364

  
**Intrinsically Safe Barriers**  
pages 365-366

  
**Timer Controllers**  
pages 367-371

  
**Particulate (Dust or Broken Bag) Transmitters**  
page 372

  
**Particulate (Dust or Broken Bag) Sensors**  
pages 373-374

  
**Control Enclosures**  
pages 375-376

## FEATURED PRODUCTS

### GRAPHICAL USER INTERFACE PANEL METER SERIES SPPM2 | page 348



- Large touch screen display allows for easy visibility and setup
- Free design software allows seamless drag and drop functionality to quickly develop unique interface

### PARTICULATE TRANSMITTER SERIES PMT2 | page 372



- Non-stick PTFE coated probe to prevent false readings from moist and conductive dusts, condensate, and dust buildup
- Simple 2-wire installation for PLC and control panels

# PANEL METERS

## Displays



SERIES	SPPM2 - page 348	SPPM - page 349	DPM - page 350	DPMX - page 351
Display	Graphical full color TFT	Graphical full color TFT	3-1/2 digit, or 4-1/2 digit, 7 segment backlit LCD (amber, green or red)	3-1/2 digit, 7 segment backlit LCD (red)
Panel Size	4.3" diag.	2.4", 2.8", 3.5" diag.	2-3/8" by 1-1/8"	10-19/32" by 4-5/32"
Display Units	User defined	User defined	None, °F, °C, %, psi, V, A, KW, PF	None
Input Signal	4 analog (0-50 mA, or 0-40 VDC), 8 digital I/O	0-50 mA, or 0-40 VDC	4-20 mA, 0-200 mVDC, 0-5 VDC, 0-10 VDC	4-20 mA, 0-200 mVDC, 0-5 VDC, 0-10 VDC
Output	2 digital I/O, 4 PWM	None	None	None

# SWITCHES & TRANSFORMERS

## Current Sensors



SERIES	SCS - page 356	MCS - page 357	CCS - page 357	MSCS - page 358
Type	Current switch	Miniature switch	Current switch	Miniature switch
Case	Solid or split core	Solid core or terminal	Solid or split core	Split core
Range	0.15 A to 200 A	0.5 to 50 A or 0.01 to 1 A	0.5 to 200 A	0.15 to 60 A (0.15 A fixed set point)
Output	1 A @ 30 VAC/DC NO solid state output; Optional 10 A @ 260 VAC (5 A @ 30 VDC) SPST relay	0.3 A @ 130 VAC/DC NO output	0.3 A @ 135 VAC/DC NO output or 1 A @ 240 VAC NO output	1 A @ 30 VAC/DC NO solid state output

These Selection Guides are for quick comparison of similar products. Please refer to the catalog page number referenced for complete product information and specifications.

# PANEL METERS

## Displays



SERIES	LCI132 - page 351	PM - page 352	LPI/BPI - page 353
Display	4 digit, 7 segment LED (red)	2 - 6 digit, 7 segment LED (red)	4 digit LCD or LED
Panel Size	1/32 DIN	1/8 DIN	Stand alone
Display Units	None	User defined	None
Input Signal	V (DC), mA (DC) or V (AC), A (AC/DC)	mA, V DC, pulse, open collector, NPN, PNP, switch contact	4-20 mA, Thermocouple, or RTD
Output	None	None, 4-20mA, or Relay	None

# SWITCHES & TRANSFORMERS

## Current Sensors



SERIES	SSCS - page 358	CCT40/50 - page 359	CCT60/70 - page 359
Type	Current switch with set point based on motor HP	Current transformer	Current transformer
Case	Split core	Solid or split core	Solid or split core
Range	1 to 100 HP	10/20/50 A or 100/150/200 A	10/20/50 A or 100/150/200 A
Output	1 A @ 30 VAC/DC NO solid state output; Optional 10 A @ 260 VAC (5 A @ 30 VDC) SPST relay	0-5 VDC, 0-10 VDC, or 4-20 mA	4-20 mA, true RMS

# POWER SUPPLIES & TRANSFORMERS

## Power Converters



**APT** - page 360



**A-700** - page 361



**BPS** - page 362



**SCD-PS** - page 362

SERIES	APT - page 360	A-700 - page 361	BPS - page 362	SCD-PS - page 362
<b>Input Voltage</b>	24 VAC, 120 VAC, 240 VAC, 120/208/240/277 VAC, 120/208/240/277/480 VAC, 50/60 Hz	100/120/220/230/240 VAC $\pm 10\%$ . 47 to 63 Hz	24 VAC/VDC 50/60 Hz	120 to 240 VAC/VDC, 50/60 Hz
<b>Output Voltage</b>	24 VAC	24-28 VDC regulated	1.5-27 VDC (full wave rectified and regulated) adjustable 1.5-29 VDC	24 VDC $\pm 3\%$
<b>Output Current</b>	20, 40, 75, 100, 150 VA	Options from 0.5 A to 4.8 A	0.5 A or 1.5 A	1 A

# POWDER, BULK, DUST COLLECTION, AND PNEUMATIC CONVEYING SENSORS

## Particulate Sensors



**PMT2** - page 372









**PMS** - page 374

SERIES	PMT2 - page 372	PMS - page 374
<b>Wetted Materials</b>	316L SS, silicone, and PTFE	316 SS and PFA or 316 SS and ceramic
<b>Process Temperature Limit</b>	-40 to 248°F (-40 to 120°C)	250°F (121°C), 450°F (232°C), 800°F (426°C), or 1200°F (649°C)
<b>Pressure Limit</b>	30 psi	10 or 100 psi
<b>Output</b>	4-20 mA	pA



# DUST COLLECTOR PULSE VALVE CONTROLLERS

Timers

						
<b>SERIES</b>	<b>SVT</b> - page 367	<b>DCT500A</b> - page 368	<b>DCT500ADC</b> - page 368	<b>DCT600</b> - page 369	<b>DCT1000</b> - page 370	<b>DCT1000DC</b> - page 371
<b>Output Channels</b>	2, 3, 4, 5, or 6; up to 60 with expansion board. Housing includes pilot solenoid valves	4, 6, or 10	4, 6, or 10	4, 6, 10, 22, or 32	6, 10, or 22; up to 255 with expansion board	6, 10, or 22; up to 255 with expansion board
<b>Input</b>	Dry contact	Dry contact	Dry contact	Dry contact	Dry contact or integral pressure sensor	Dry contact or integral pressure sensor
<b>Power</b>	90-240 VAC or 24 VAC/DC	102-132 VAC	10-35 VDC	85-270 VAC	85-270 VAC	10-30 VDC
<b>Size</b>	See catalog page	4-7/8" by 6-3/4"	4-7/8" by 6-3/4"	4-7/8" by 6-3/4" or 6-7/8" by 8-3/4"	6-7/8" by 8-3/4"	6-7/8" by 8-3/4"
<b>Approvals</b>	CE	CE, cULus	CE	CE, cULus	cULus	CE

These Selection Guides are for quick comparison of similar products. Please refer to the catalog page number referenced for complete product information and specifications.



**Monitor the test environment for accurate laboratory tests.**

The Love Controls® Model LCR20 dual pen circular chart recorder can be used to monitor the humidity and temperature in an environmental chamber. The 10" chart size makes it easy to see the blue and red pen markings on the chart paper. The recorder takes in most common thermocouples and process inputs for both channels. It is recommended that the LCR20 be used with a Dwyer® RHP series humidity / temperature transmitter for best results.

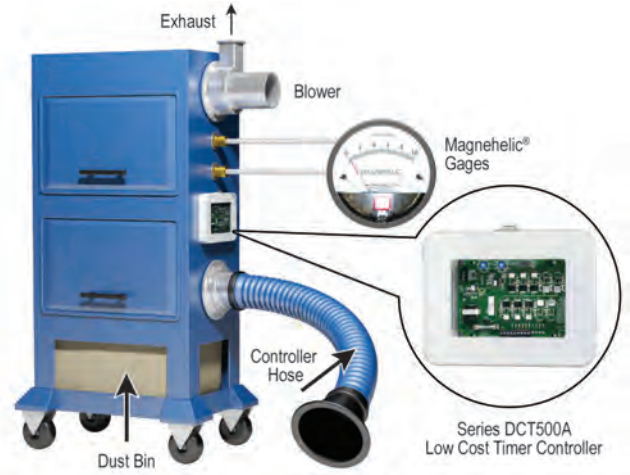

**Dust Collector Timer Controller shows filter condition in dust collector.**

This portable dust collector can be rolled from job to job in an industrial building. An operator places the large diameter collection hose where it is needed and dust is collected by filters located inside the access doors on the units side. The top mounted blower draws air through the filters. To monitor the pressure drop across the filters, the manufacturer supplies a Magnehelic® differential pressure gage. When the pressure drop due to dust build up on the filter indicates that cleaning is necessary, the DCT500A Dust Collector Timer Controller is manually activated to initiate a cleaning cycle which involves solenoid valves releasing pulses of air. This process removes the dust from the filters where it drops into a storage bin. A Dwyer® Minihelic® differential pressure gage can be used instead of the Magnehelic® gage, and, if automatic cleaning is required, a Photohelic® differential pressure switch/gage can provide the electrical contact to actuate the cleaning cycle when the pressure drop reaches the preset limit.



**Button Data Logger monitors food and beverage temperature in refrigerated transport vehicles.**

When transporting temperature-sensitive products such as meat, produce, beer and wine over long distances, it is necessary to verify that the storage compartment has not exceeded the critical preservation temperature at any time. Dwyer® BDL Button Data Loggers offer a low cost way to measure and record storage temperatures throughout transport. By placing several "buttons" throughout the storage compartment and setting an appropriate measurement interval, transportation services can retrieve data at the completion of delivery to assure their customers of adequate preservation temperatures.

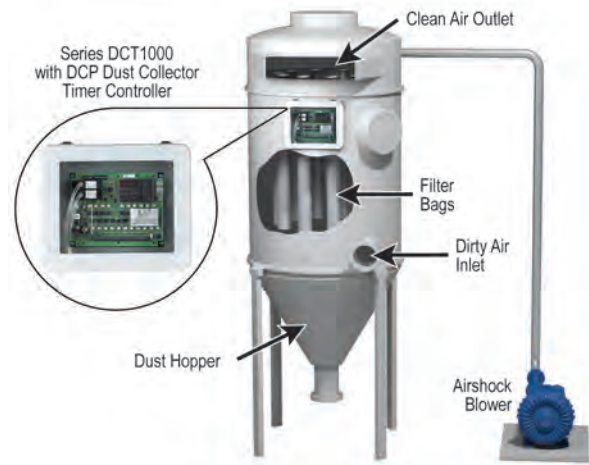

**Bag house cleaning system uses Dust Collector Timer Controller to initiate optimum cleaning cycle.**

A Dwyer® DCT1000 Dust Collector Timer Controller with attachable DCP pressure sensing module monitors and controls the dust levels and corresponding pressure drop across the filter bags. The DCT1000/DCP control automatically activates the cleaning cycle when the DCT1000's pre-programmed set points have been exceeded. This on-demand control system alleviates excessive air compressor usage by preventing unnecessary cleaning which lowers energy and maintenance costs.

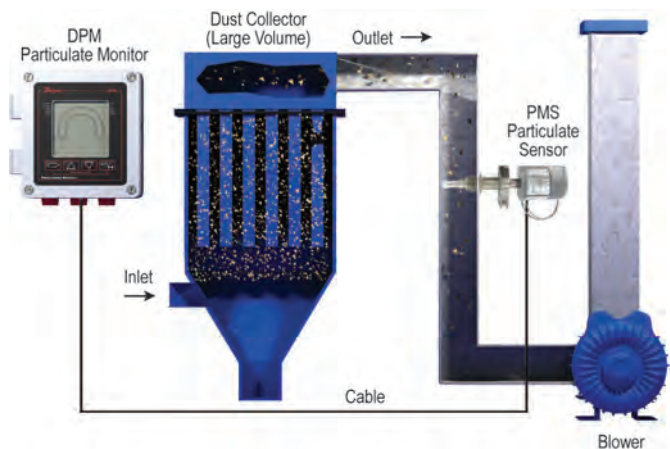

**Detect broken filters in dust collectors.**

The Dwyer® Series DPM Particulate Monitor and PMS Particulate Sensor combine to make a particulate monitoring system for the exhaust stream of dust collectors. The amount of particulate leaking out of the dust collector is measured using low maintenance induction technology and shown on a display for easy viewing. The DPM has programmable thresholds of leakage for switch output indication of dust collector problems such as broken or leaking filters. Proper use of the system will allow the user to catch breaking filters early. Advantages of the system are maintaining regulatory compliance, maximizing product recovery, optimizing filtration efficiency, preventing fines and plant shutdowns, and reducing the amount of pollutants released.

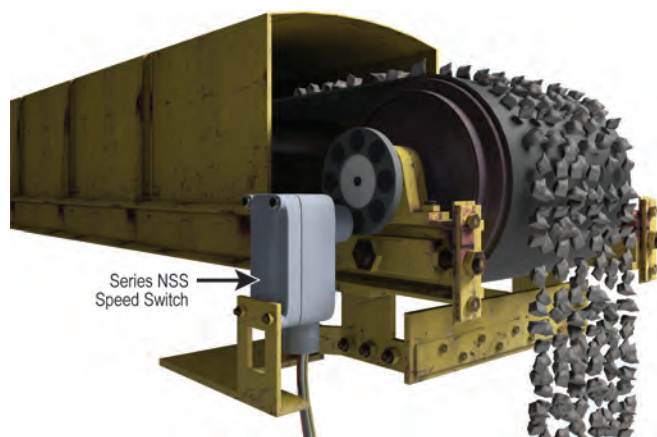

**Monitoring belt conveyor for proper operation.**

A Proximity® Series NSS Speed Switch is used to monitor the speed of a product belt conveyor indicating proper operation. Common applications include grain, feed, aggregate, mining, and textiles. Belt slippage or a slowdown in belt speed indicates problems that could lead to product waste or could generate sparks leading to a fire or explosion. The belt's speed is monitored via the rotational speed of the shaft at the end of the belt. The NSS is a non-contact magnetic actuated system allowing easy installation and long operational life. A magnetic disc is installed on the rotating shaft and the sensor is mounted across from it. The sensor picks up the rotation of the disc to detect the rotational speed of the belt. Inside the sensor is a programmable switch that can be set for any speed. In this application as the speed decreases and hits the set point the switch is activated for indication of a problem. Proper usage of an NSS can help with predictive maintenance and decrease down-time.

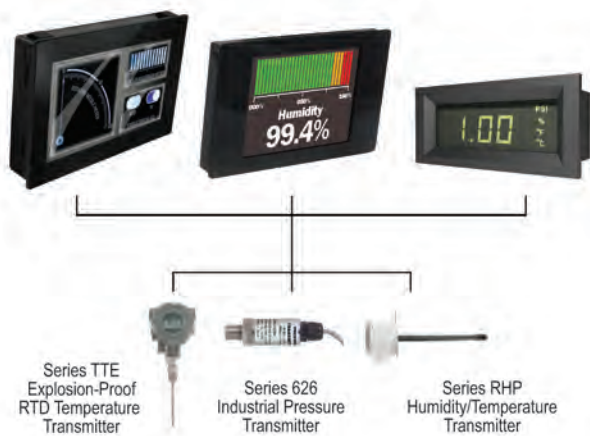

**Providing remote indication of pressure, humidity or temperature.**

The Series DPML, DPMP, and DPMW Digital LCD Panel Meters as well as the SPPM and SPPM2 HMI Panel Meters provide remote indication in the designated engineering units for pressure, humidity, temperature as well as customizable measurement units. The panel meters can take a voltage or current input signal from transmitters such as the Dwyer® TTE, Series 626 or Series RHP.

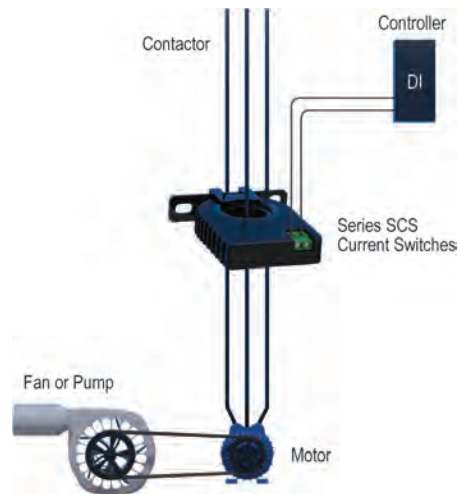

**Monitor the status of your fan or pump.**

The Dwyer® Series SCS Current Switches monitor the input current into a fan or pump motor starter in order to monitor the status of the equipment. As the current passes through the core of the switches, it generates enough energy to power up the switch eliminating the need for extra power wires. The solid core models are typically used on new installations, while the split core models are able to mount on existing or new installations.

Typical Applications



# GRAPHICAL USER INTERFACE PANEL METER

4.3" (109 mm) Touch Screen Display, Fully Customizable

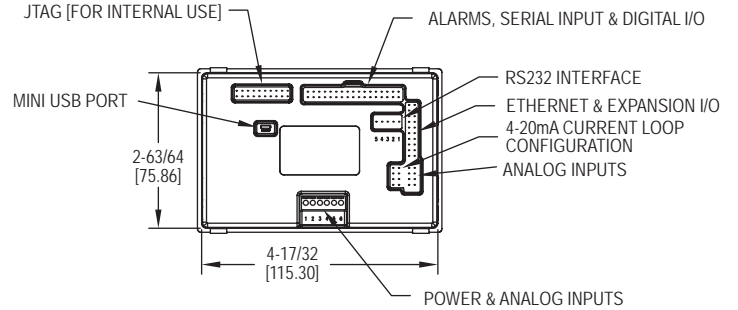
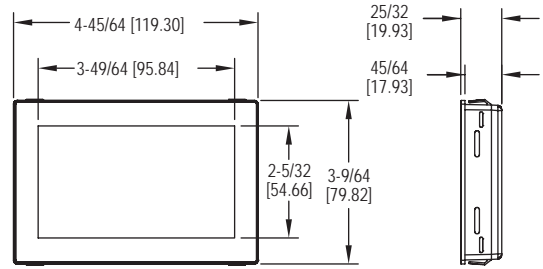

The **Series SPPM2 Graphical User Interface Panel Meter** is a configurable, full-color 4.3" (109 mm) touch screen display that can be used in a variety of applications. By using the free Windows® based Interface Panel Design Studio software, users can personalize the display with buttons, switches, and analog and digital scales to suit their needs. A development kit is also available, which includes a development board with buttons, dials, LEDs, and screw terminals to test the functionality of all inputs and outputs.

### FEATURES/BENEFITS

- Large 4.3" touch screen display can be powered from USB or 5-30 VDC supply
- Free design software allows users to drag and drop elements onto the screen to quickly develop their specific interface
- Accepts up to 4 analog inputs, 8 digital I/O, 4 PWM outputs, and 2 open collector alarm outputs

### APPLICATIONS

- Lift station pump control
- Room condition monitoring display
- Walk-in refrigeration/freezer control

MODEL CHART	
Model	Description
SPPM2-43	4.3" interface panel
SPPM2-43-D	4.3" interface panel with development board

### SPECIFICATIONS

**Inputs:** Mini-USB, 6-line screw terminal analog, 4 x ±40 V, or 4-20 mA, 8 x digital I/O.  
**Outputs:** 4 x PWM, 2 x alarms (open collector).  
**Accuracy:** ±0.05% ±0.1 mV (typ).  
**Resolution:** 0.04 mV (max ) or 4 decimal places.  
**Power Supply:** USB port or 5-30 VDC.  
**Current Consumption:** 400 mA at 5 VDC.  
**Display:** 4.3" (10.9 cm) TFT LCD with 262k colors.  
**Display Resolution:** 480 x 272 pixels.  
**Sampling Rate:** 10 samples/s.  
**Temperature Limits:** 32 to 104°F (0 to 40°C).  
**Warm Up:** 15 s.  
**Mounting:** Panel mount.  
**Electrical Connection:** Multi-pin DIL's, 1 mini-USB, and 1 RS232.  
**Software Requirements:** Compatible with Windows® 7, Windows® 8 and Windows® 10.  
**Weight:** 6.7 oz (181 g).  
**Approvals:** CE.

### DEVELOPMENT BOARD SPECIFICATIONS

**Inputs:** 4 x ±5 VDC.  
**Outputs:** 8 x digital I/O's, 4 x PWM outputs.  
**Serial Communication:** RS232.  
**Power Supply:** USB port or 5-30 VDC.  
**Weight:** 19.7 oz (560 g).

Panel Meters/  
Indicators

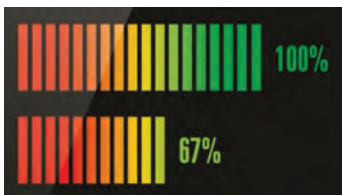
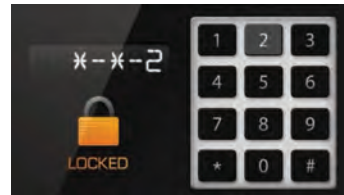

Windows® is a registered trademark of Microsoft Corporation.



# SMART PROGRAMMABLE PANEL METERS

Fully Field Configurable, 16-Bit Color Touch Screen Display

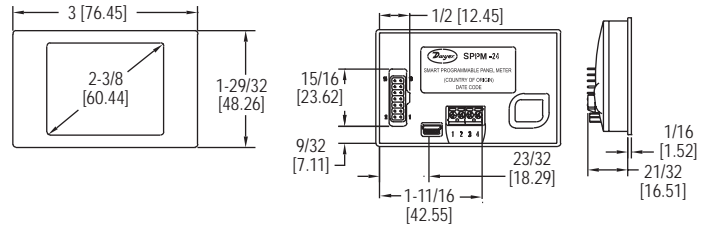

SPPM-24 and SPPM-24-C

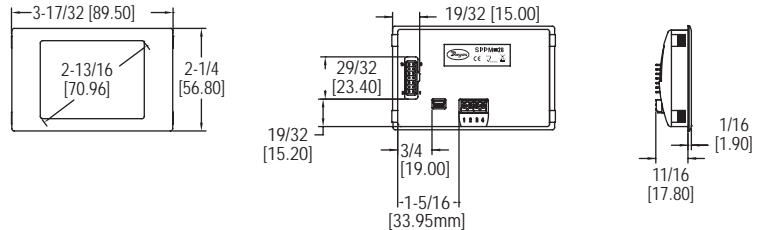

SPPM-28 and SPPM-28-C

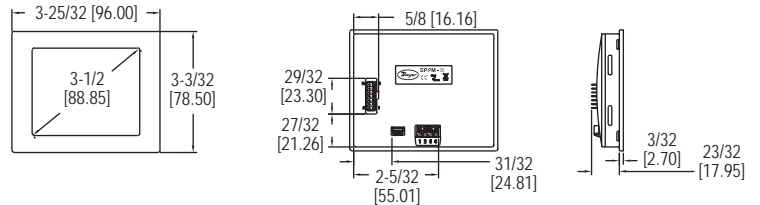

SPPM-35 and SPPM-35-C

SPPM-HSG

The Series SPPM Smart Programmable Panel Meters are configurable full-color touch screen displays that can be used in a variety of applications. By using a USB connection, the panel meter can be configured with downloadable software for any computer running Windows® based software. The display features remarkable graphics that can easily be customized to read and/or graph pressure, temperature, humidity, gas concentration, or many other parameters.

### FEATURES/BENEFITS

- Available with 2.4", 2.8", or 3.5" color touch screen display
- Free downloadable Windows® software allows the unit to be customized to specific applications

### APPLICATIONS

- Tank level
- Power monitoring
- Room pressurization condition
- Indoor air quality conditions

### SAMPLE PROGRAMMABLE DISPLAY CONFIGURATIONS



### SPECIFICATIONS

#### SPPM SPECIFICATIONS

**Inputs:** Current: 0-50 mA, scalable (factory set from 4-20 mA); Voltage: 0-40 VDC, scalable (factory set from 0-10 V).  
**Accuracy:** 0.1%.  
**Resolution:** 0.3 to 9.8 mV (depending on input range).  
**Power Supply:** 4-30 VDC max or via USB.  
**Current Consumption:** 190 mA max.  
**Display:** 2.4", 2.8" or 3.5" TFT full color touch screen.  
**Display Resolution:** 320 x 240 pixels.  
**Sampling Rate:** 3 samples/s.  
**Temperature Limits:** 32 to 104°F (0 to 40°C).  
**Warm Up:** 30 s.  
**Mounting:** Panel mount.  
**Electrical Connection:** Screw terminals, pin connection, or USB.  
**Computer Requirements:** Compatible with Windows® 7, Windows® 8 and Windows® 10.  
**Weight:** 2.8 oz (79.4 g).  
**Agency Approvals:** CE.

#### SPPM-HSG SPECIFICATIONS

**Service:** Indoor or outdoor.  
**Material:** Painted aluminum or glass.  
**Enclosure Rating:** NEMA 4X (IP66).  
**A-SPPM-TC SPECIFICATIONS**  
**Probe Measurement Range:**  
 K-type: -328 to 2462°F (-200 to 1350°C);  
 J-type: -328 to 2174°F (-200 to 1190°C);  
 T-type: -328 to 734°F (-200 to 390°C).  
**Temperature Limits:** 14 to 104°F (-10 to 40°C).  
**Resolution:** 1.0°F (0.5°C).  
**Power Requirements:** Powered by USB port through SPPM panel meter.  
**Accuracy:** ±2.0°F (±1.0°C).  
**Weight:** 0.9 oz (25.5 g).  
**Agency Approvals:** CE.

### MODEL CHART

Model	Display	Input
SPPM-24	2.4"	Voltage
SPPM-28	2.8"	Voltage
SPPM-35	3.5"	Voltage
SPPM-24-C	2.4"	Current
SPPM-28-C	2.8"	Current
SPPM-35-C	3.5"	Current

### ACCESSORIES

Model	Description
A-SPPM-TC	Thermocouple input board
SPPM-CA	Mini USB to full USB cable
SPPM-HSG24	2.4" display housing
SPPM-HSG28	2.8" display housing

**Note:** Additional configurations available via online software.

Windows® is a registered trademark of Microsoft Corporation



SERIES DPMA, DPMW, DPMP, & DPML

# LCD DIGITAL PANEL METERS

3-1/2 & 4-1/2 Digit LCD, User Selectable Engineering Units, Panel Mount



DPMA



DPMW



DPMP



DPML

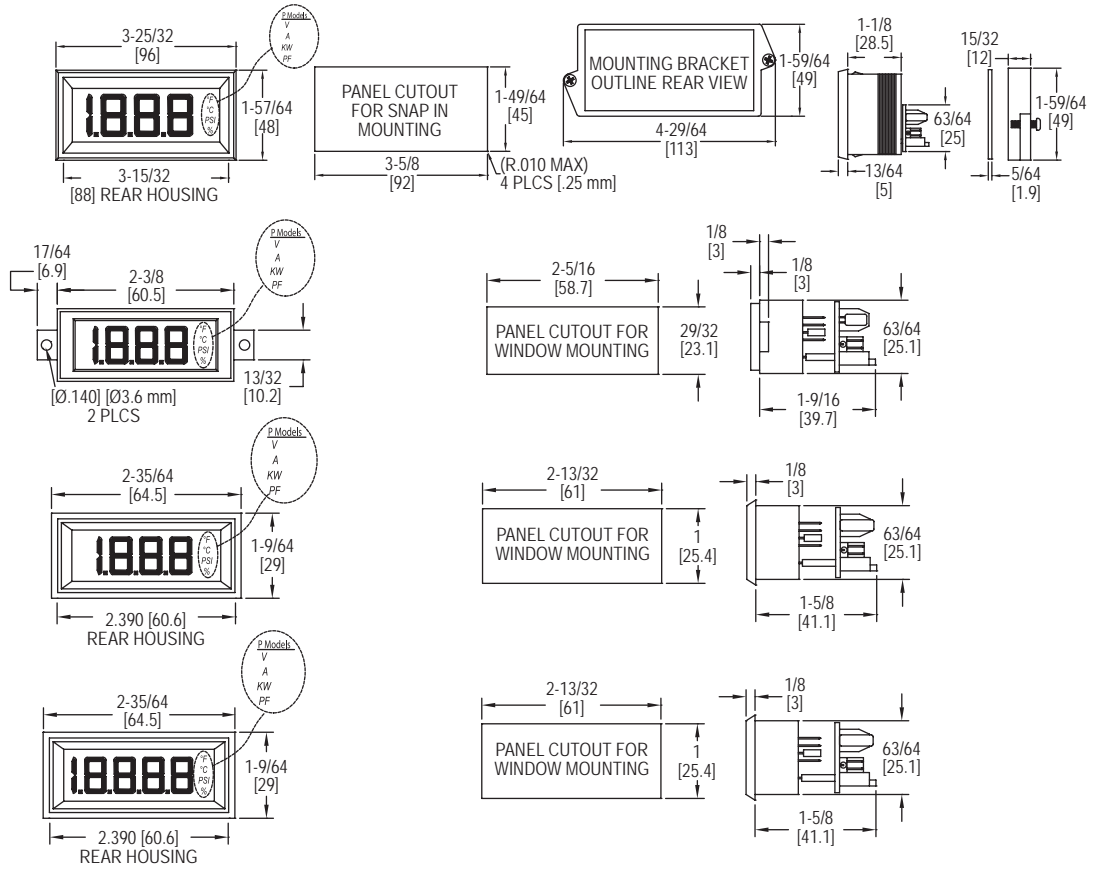

The Series DPMA, DPMW, DPMP, & DPML LCD Digital Panel Meters provide easy viewing on the 3-1/2 or 4-1/2 digit LCD display. On the DPMP and DPML the snap-in bezel mount eliminates mounting hardware for quick installation. The DPMA has a high contrast display for easy viewing in a standard 1/8 DIN package. The DPMW window mounts using two screws to sit flush within the panel cutout. This series can accept 4 to 20 mA, 0 to 200 mVDC, 0 to 5 VDC, or 0 to 10 VDC input signal and requires a 24 VDC power supply to illuminate the colored segments.

**FEATURES/BENEFITS**

- Panel mount for quick installation
- 3-1/2 or 4-1/2 digit with 0.45" or 1" segments
- Colored segments available in black, red, amber, green, or blue
- Jumper selectable engineering units and decimal point positions

**APPLICATIONS**

- Display process values from pressure, humidity, temperature, voltage, current, watt, or power factor transmitters

**ACCESSORIES**

Model	Description
DPM-12P	Regulated 120 VAC to 12 VDC power supply
DPM-24P	Regulated 120 VAC to 24 VDC power supply

**SPECIFICATIONS**

**Input:** DPMX-4XX(P): 4 to 20 mA; DPMX-5XX(P): 0 to 200 mVDC, 0 to 5 VDC, or 0 to 10 VDC.  
**Input Impedance:** DPMX-4XX(P): 300Ω nominal; DPMX-5XX(P): 390Ω nominal.  
**Accuracy:** DPMA: ±(0.05% FS + 1 count); DPMW/P/L: ±(0.1% FS + 2 count).  
**Power Supply:** DPMX-4XX(P): Powered by control loop; DPMX-5XX(P): 12 VDC or 24 VDC.  
**Backlight Power Supply:** 24 VDC @ 35 mA typical.  
**Span and Zero:** Adjustable (±1999 counts).  
**Display:** DPMA: 3-1/2 digits, 7 segments, 1" (25.4 mm) H; DPMP/W: 3-1/2 digits, 7 segments, 0.45" (11.4 mm) H; DPML: 4-1/2 digits, 7 segments, 0.45" (11.4 mm) H.  
**Decimal Points:** DPMA/W/P: 3-position, user selectable; DPML: 4-position, user selectable.  
**Polarity:** Automatic, "-" displayed.  
**Operating Temperature:** 32 to 122°F (0 to 50°C).  
**Storage Temperature:** -4 to 158°F (-20 to 70°C).  
**Mounting:** DPMA: Snap-in panel mount or clamp (gasket included); DPMW: Window mount; DPMP/L: Snap-in bezel mount.  
**Connection:** Screw terminals.  
**Conversion Rate:** 3 per s.  
**Warm-Up:** 10 minutes typical.  
**Weight:** DPMA: 4 oz (113.4 g); DPMW/P/L: 2 oz (56.7 g).

**MODEL CHART**

Model	Input	Segments	Engineering Units	Digit	Model	Input	Segments	Engineering Units	Digit
DPMA-401	Current	Amber	°F, °C, %, psi	3-1/2"	DPMW-401P	Current	Amber	V, A, KW, PF	3-1/2"
DPMA-402	Current	Red	°F, °C, %, psi	3-1/2"	DPMW-402P	Current	Green	V, A, KW, PF	3-1/2"
DPMA-404	Current	Green	°F, °C, %, psi	3-1/2"	DPMW-403P	Current	Red	V, A, KW, PF	3-1/2"
DPMA-501	Voltage	Amber	°F, °C, %, psi	3-1/2"	DPMP-401*	Current	Amber	°F, °C, %, psi	3-1/2"
DPMA-502	Voltage	Red	°F, °C, %, psi	3-1/2"	DPMP-402*	Current	Green	°F, °C, %, psi	3-1/2"
DPMA-504	Voltage	Green	°F, °C, %, psi	3-1/2"	DPMP-403*	Current	Red	°F, °C, %, psi	3-1/2"
DPMA-401P	Current	Amber	V, A, KW, PF	3-1/2"	DPMP-501*	Voltage	Amber	°F, °C, %, psi	3-1/2"
DPMA-402P	Current	Red	V, A, KW, PF	3-1/2"	DPMP-502*	Voltage	Green	°F, °C, %, psi	3-1/2"
DPMA-404P	Current	Green	V, A, KW, PF	3-1/2"	DPMP-503*	Voltage	Red	°F, °C, %, psi	3-1/2"
DPMA-501P	Voltage	Amber	V, A, KW, PF	3-1/2"	DPMP-401P*	Current	Amber	V, A, KW, PF	3-1/2"
DPMA-502P	Voltage	Red	V, A, KW, PF	3-1/2"	DPMP-402P*	Current	Green	V, A, KW, PF	3-1/2"
DPMA-504P	Voltage	Green	V, A, KW, PF	3-1/2"	DPMP-403P*	Current	Red	V, A, KW, PF	3-1/2"
DPMW-401	Current	Amber	°F, °C, %, psi	3-1/2"	DPMP-501P*	Voltage	Amber	V, A, KW, PF	3-1/2"
DPMW-402	Current	Green	°F, °C, %, psi	3-1/2"	DPMP-502P*	Voltage	Green	V, A, KW, PF	3-1/2"
DPMW-403	Current	Red	°F, °C, %, psi	3-1/2"	DPMP-503P*	Voltage	Red	V, A, KW, PF	3-1/2"

\*For 4-1/2 digit display, change DPMP to DPML. Example: DPML-401

# EXTRA LARGE DIGITAL PANEL METER

## 3-1/2 Digit LED Display, 2.3" Segment Height, Process Inputs

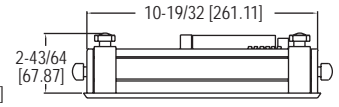
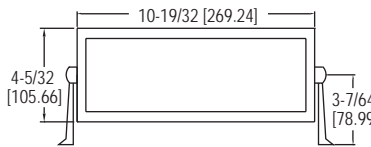
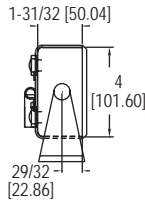

The **Series DPMX Extra Large Digital Panel Meter** can be easily viewed from across a room or in dark areas. The 2.3" LED segments are available in red, green, or blue. These panel meters come equipped with a universal power supply and user selectable process inputs to fit most applications.

### FEATURES/BENEFITS

- Large 10.6" (269.2 mm) x 4.2" (105.7 mm) backlit display
- Protective metal casing with adjustable mounting bracket

### APPLICATIONS

- Display process values from various transmitters

### MODEL CHART

Model	Segments	Power Supply
DPMX-1	Blue	90 to 250 VAC
DPMX-2	Green	90 to 250 VAC
DPMX-3	Red	90 to 250 VAC
DPMX-1-LV	Blue	10.5 to 30 VAC/VDC
DPMX-2-LV	Green	10.5 to 30 VAC/VDC
DPMX-3-LV	Red	10.5 to 30 VAC/VDC

### SPECIFICATIONS

**Inputs:** Set voltage:  $\pm 200$  mVDC,  $\pm 2$  VDC,  $\pm 20$  VDC; Adjustable voltage: 200 mVDC, 5 VDC, 10 VDC; Adjustable current: 0(4)-20 mA DC.  
**Input Impedance:** Set voltage:  $>1$  M  $\Omega$  ( $>10$  M  $\Omega$  on 200 mV range); Adjustable voltage: 392 k $\Omega$ ; Adjustable current: 300  $\Omega$  nominal.  
**Accuracy:**  $\pm(1\%$  FS + 1 count).  
**Power Supply:** 90-250 VAC @ 12 VA or 10.5-30 VAC/DC @ 6 VA (depending on model).  
**Display:** 3-1/2 digits, 2.3" H, 7 segment LED.  
**Sampling Rate:** 3 readings per s.  
**Operating Temperature:** 14 to 122°F (-10 to 50°C).  
**Storage Range:** -40 to 167°F (-40 to 75°C).  
**Warm Up:** 10 minutes.  
**Mounting:** 180° gimbal mounting with 30° stops or bezel mount.

## SERIES LCI132

# COMPACT PROCESS INDICATOR

## 1/32 DIN, Fully Programmable



Process display

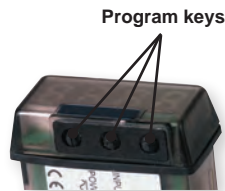

Program keys

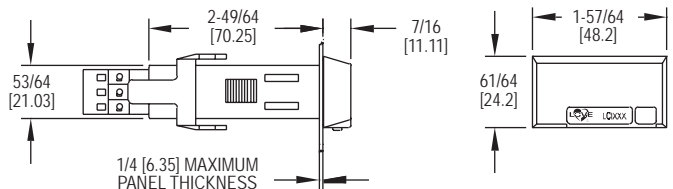

The **Series LCI132 Compact Process Indicator** offers flexibility and value in a low cost, compact 1/32 DIN package. The shallow depth of these full size panel meters allows installation in panels only 2.76" (70 mm) deep with room to spare.

### FEATURES/BENEFITS

- Fits in 1/32 DIN panel cutouts
- IP65 (NEMA 4X) front housing
- Fully programmable
- Various voltage and current inputs fit most processes

### APPLICATIONS

- Display process values from various transmitters

### MODEL CHART

Model	Input	Supply Voltage
LCI132-00	$\pm 100$ VDC; $\pm 20$ VDC; $\pm 10$ VDC; $\pm 200$ VDC; $\pm 20$ mA DC	120/240 VAC
LCI132-01	$\pm 100$ VDC; $\pm 20$ VDC; $\pm 10$ VDC; $\pm 200$ VDC; $\pm 20$ mA DC	24/48 VAC
LCI132-10	$\pm 100$ VAC; 600 VAC; 5 A (DC) 1 A (AC); -199.9 to +600 VDC; $\pm 100$ VDC -1.999 to 5 A (DC) $\pm 1$ A (DC)	120/240 VAC
LCI132-11	$\pm 100$ VAC; 600 VAC; 5 A (DC) 1 A (AC); -199.9 to +600 VDC; $\pm 100$ VDC -1.999 to 5 A (DC) $\pm 1$ A (DC)	24/48 VAC

### SPECIFICATIONS

**LCI132-0X**  
**Range:** Input volts (DC):  $\pm 200$  V,  $\pm 20$  V,  $\pm 10$  V; Input amperes:  $\pm 100$  mV,  $\pm 20$  mA.  
**Resolution:** Input volts (DC): 0.1 V, 0.01 V, 1 mV; Input amperes: 0.1 mV, 0.01 mA; Input impedance: Volts: 1 M $\Omega$ , mV: 100 M $\Omega$ , mA: 12.1  $\Omega$ .  
**LCI132-1X**  
**Range AC:** Input volts: 600.0, 100.0; Input amperes: 5.000, 1.000.  
**Range DC:** Input volts: -199.9,  $\pm 600.0$ ,  $\pm 100.0$ ; Input amperes: -1.999, +5.000,  $\pm 1.000$ .  
**Resolution:** Input volts: 0.1 V; Input amperes: 1 mA; Input impedance: Volts: 3 M  $\Omega$  (106), Amps: 12 m  $\Omega$  (10-3).  
**Accuracy at 23°C  $\pm 5^\circ$ C:** 100/600 VDC 1/5 A DC; 600 V/5 AAC:  $\pm(0.2\%$  reading + 3 digits). 100 V / 1 A AC:  $\pm(0.4\%$  reading + 4 digits).  
**Temperature Coefficient:** 100 ppm/ $^\circ$ C.  
**Warm Up:** 5 minutes.  
**Power Supply and Fuses (DIN 41661) (Not supplied):** LCI132-X0: 85–265 VAC 50/60 Hz and 100-300 VDC; Fuse: 0.1 A/ 250 V; LCI132-X1: 21-53 VAC 50/60 Hz and 10.5-70 VDC; Fuse 0.5 A/ 250 V.  
**DISPLAY**  
**Range:** -1999 to 9999 (DC) 0 to 9999 (AC).  
**Type:** 4 red digits 10 mm.  
**Reading Rate:** 4/s.  
**Overflow Indication:** OVR.  
**ENVIRONMENTAL**  
**Operating Temperature:** 14 to 140°F (-10 to 60°C).  
**Storage Temperature:** -13 to 185°F (-25 to 85°C).  
**Relative Humidity (non condensed):** < 95% @ 40°C.  
**Panel Sealing:** NEMA 4X (IP66).





SERIES APM, MPM & PPM



# DUAL LINE CONFIGURABLE PANEL METERS

## 1/8 DIN Multi-Pump Alternation Control, Open-Channel Flow, Rate and Totalizer

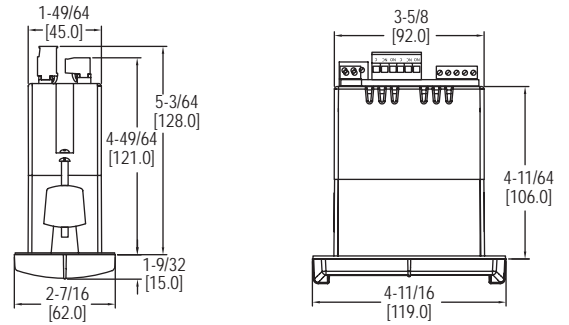

The Series PM's are a series of 1/8 DIN digital panel meters engineered to take in multiple inputs from a variety of instrumentation for the purpose of displaying or controlling a process parameter.

The **Series APM Dual Line Configurable Panel Meter** is specifically designed for displaying flow rate and total from a flow meter with an analog output such as 4-20 mA or 0-10 V. The APM is particularly well-suited for flow applications and can display flow rate and total at simultaneously.

The **Series MPM Dual Line Configurable Panel Meter** has the ability to obtain non-linear input signals and linearize them with simple to use math functions such square-root extractor, weirs and flumes exponential linearizer, horizontal round tank linearizer or general purpose 32-point linearizer. Unit accepts 0-20 mA, 4-20 mA, 0-5 V, or  $\pm 10$  V inputs and requires 85-265 VAC or 12/24 VDC power supply. Choose from RS-232, RS-422/485 serial communication options or any available expansion modules, accessories and enclosures.

The **Series PPM Dual Line Configurable Panel Meter** displays flow rate and total simultaneously, with a programmable relay and 4-20 mA options for flow rate or flow total. The PPM is designed for displaying flow rate and total from a pulsed input provided by open collector, NPN, PNP, TTL, switch contact, sine wave, or square wave.

### FEATURES/BENEFITS

- Three levels of password protection
- Math functions for flow & round horizontal tanks
- 32-point linearization, square root or programmable exponent
- Multi-pump alternation control
- Rate displayed as units per second, minute, hour, or day
- Total, grand total or non-resettable grand total
- Two or four relays & isolated 4-20 mA output options
- External 4-relay & digital I/O expansion modules
- RS-232, RS-422/485 serial communication options

### APPLICATIONS

- Level monitoring
- Pump control
- Flow rate indication
- Flow totalization
- Open channel flow monitoring
- Process control

### SPECIFICATIONS

**Input:** APM: 0-20 mA, 4-20 mA, 0-5 V, or  $\pm 10$  V inputs; MPM: 0-20 mA, 4-20 mA, 0-5 V, or  $\pm 10$  V; PPM: Field selectable: Pulse or square wave 0-5 V, 0-12 V, or 0-24 V @ 30 kHz; TTL; open collector 4.7 k $\Omega$  pull-up to 5 V @ 30 kHz; NPN or PNP transistor, switch contact 4.7 k $\Omega$  pull-up to 5 V @ 40 Hz.  
**Input Impedance:** 50 to 100  $\Omega$ .  
**Accuracy:**  $\pm 0.03\%$  of calibrated span  $\pm 1$  count, square root & programmable exponent accuracy range: 10-100% of calibrated span.  
**Power Requirements:** 85-265 VAC 50/60 Hz, 90-265 VDC, 20 W max or 12-24 VDC  $\pm 10\%$ , 15 W max.  
**Display:** Dual-line 6-digit display, 0.60 in and 0.46 in.  
**Decimal Points:** Five positions, user selectable.  
**Temperature Limits:** Operating: -40 to 149°F (-40 to 65°C); Storage: -40 to 185°F (-40 to 85°C).

**Enclosure Rating:** NEMA 4X, IP65 front.  
**Electrical Connections:** Removable screw terminal blocks accept 12 to 22 AWG wire, RJ45 for external relays, digital I/O, and serial communication adapters.  
**Output Signal:** 4-20 mA.  
**Power Consumption:** 85-265 VAC models: 200 mA @ 24 VDC; 12-24 VDC models: 100 mA @ 24 VDC; Second supply with output 2 models: 40 mA @ 24 VDC.  
**Switch Rating:** 2 or 4 SPDT (Form C) internal and/or 4 SPST (Form A) external; rated 3 A @ 30 VDC and 125/250 VAC resistive load; 1/14 HP @ 125/250 VAC for inductive loads.  
**Time Delay:** 0 to 999.9 s, on & off relay time delays; programmable and independent for each relay.  
**Shipping Weight:** 9.5 oz (269 g).  
**Agency Approvals:** CE, UL.

### OPEN CHANNEL FLOW CAPABILITY

Series APM when utilized with an ultrasonic level transmitter, such as the Mercoid Series ULT, provides an economical way to measure open channel flow.

### DIFFERENTIAL PRESSURE FLOW

The APM can display flow rate and total by extracting the square root from the 4-20 mA signal from a differential pressure transmitter, such as the Dwyer 629, that is being used with a flow element such as Dwyer orifice plate Series OP or TE. The user-selectable, low-flow cut-off feature gives a reading of zero when the rate is below a user selectable value.

### PUMP CONTROL

With the two or four contact output option the APM or MPM can be used as a programmable pump controller when used with a Dwyer level transmitter. The APM also has programmable on and off points for up to four pumps, quadruplex pumping systems with alternation capability. When using the 4-relay model with the four external relay accessory, the APM can do 8 contacts for any combination of pump control and 8 programmable alarms.

MODEL CHART					
Model	Model	Model	Power	Output 1	Output 2
APM-100	MPM-100	PPM-100	85-265 VAC	None	None
APM-101	MPM-101	PPM-101	85-265 VAC	None	4-20 mA
APM-120	MPM-120	PPM-120	85-265 VAC	2 relays	None
APM-121	MPM-121	PPM-121	85-265 VAC	2 relays	4-20 mA
APM-140	MPM-140	PPM-140	85-265 VAC	4 relays	None
APM-141	MPM-141	PPM-141	85-265 VAC	4 relays	4-20 mA
APM-200	MPM-200	PPM-200	12-24 VDC	None	None
APM-201	MPM-201	PPM-201	12-24 VDC	None	4-20 mA
APM-220	MPM-220	PPM-220	12-24 VDC	2 relays	None
APM-221	MPM-221	PPM-221	12-24 VDC	2 relays	4-20 mA
APM-240	MPM-240	PPM-240	12-24 VDC	4 relays	None
APM-241	MPM-241	PPM-241	12-24 VDC	4 relays	4-20 mA

ACCESSORIES	
Model	Description
PMA-01	RS-232 serial adapter
PMA-02	Meter copy cable
PMA-03	RS-422/485 serial adapter
PMA-04	RS-232 to RS-422/485 isolated converter
PMA-05	RS-232 to RS-422/485 non-isolated converter
PMA-06	USB to RS-232 non-isolated converter
PMA-07	USB to RS-422/485 isolated converter
PMA-08	USB to RS-422/485 non-isolated converter
PMA-09	Snubber
PMA-10	DIN rail mounting kit for two modules
PMA-11	4 relay expansion module
PMA-12	4 digital inputs and 4 digital outputs module



# LOOP POWERED PROCESS INDICATOR

## Square Root Function and User Defined Curves 4-Digit LED

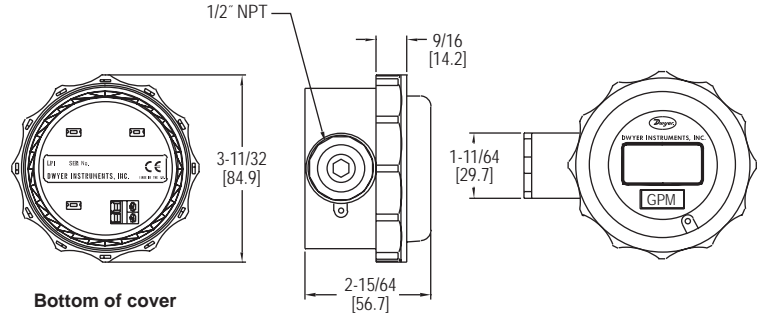

The **Model LPI Loop Powered Process Indicator** accepts a 4-20 mA input signal and displays the associated process variable such as pressure, level, flow, temperature, or relative humidity. The indicator is housed in a NEMA 4X (IP66) polycarbonate enclosure with a 1/2" female NPT side port. Users can quickly modify the instrument configuration via three push-buttons on the front of the unit.

**FEATURES/BENEFITS**

- NEMA 4X (IP66) enclosure for outdoor applications
- Programmable input/output scaling, engineering units, offset, decimal point position, and password protection
- Bright red four-digit LED

**APPLICATIONS**

- Displays process values from various transmitters

**SPECIFICATIONS @ 68°F (20°C)**

**Input:** 4-20 mA.  
**Maximum Input Current:** 100 mA for 1 minute.  
**Accuracy:** ±0.02% FS.  
**Stability:** Zero: 0.002%/°C; Span: 100 ppm/°C.  
**Power Requirements:** 2-wire 4-20 mA loop powered.  
**Display:** 4-digit, 7.6 mm (high) red LED.  
**Maximum Display Range:** -1999 to 9999.  
**Ambient Operating Temperature:** -4 to 167°F (-20 to 75°C).  
**Storage Temperatures:** -58 to 185°F (-50 to 85°C).  
**Weight:** 6.0 oz (170 g).  
**Front Panel Protection:** NEMA 4X (IP66).  
**Agency Approvals:** CE.

**MODEL CHART**

Model	Description
LPI-111	Loop powered indicator with plastic enclosure

**SERIES BPI**

# BATTERY POWERED TEMPERATURE INDICATOR

## RTD or T/C Input, 4-Digit Display, Selectable °F or °C

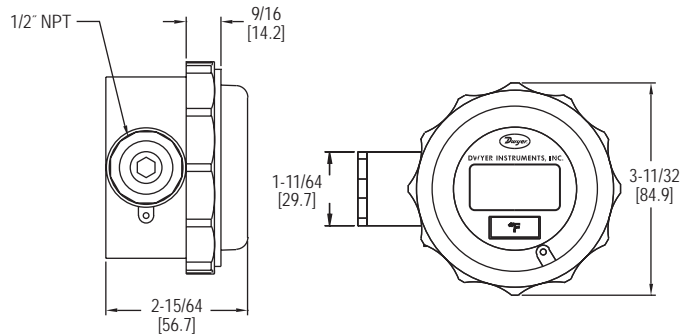

The **Series BPI Battery Powered Temperature Indicator** accepts RTD or thermocouple input and provides local or remote display of temperature measurements. The indicator is housed in a NEMA 4X (IP66) enclosure for additional protection from the environment. Users can quickly modify the instrument configuration via three push-buttons on the front of the unit.

**FEATURES/BENEFITS**

- Programmable input type, engineering units (°F/°C), offset temperature, decimal point position, and password protection
- Four-digit segmented display

**APPLICATIONS**

- Provides local temperature indication in areas without power availability

MEASURING RANGES	
Sensor	Range °F (°C)
K	-328 to 2498 (-200 to 1370)
J	-148 to 2192 (-100 to 1200)
T	-346 to 752 (-210 to 400)
N	-292 to 2372 (-180 to 1300)
R	14 to 3200 (-10 to 1760)
S	14 to 3200 (-10 to 1760)
E	-328 to 1832 (-200 to 1000)
F	-148 to 1112 (-100 to 600)
Pt100Ω	-148 to 1472 (-100 to 800)
Ni120	-148 to 1472 (-100 to 800)

**SPECIFICATIONS**

**Inputs:** Thermocouple or RTD depending on model.  
**Accuracy:** Thermocouple input: ±0.1% FS, ±0.5°C (plus sensor); RTD: ±0.2°C ±0.1% of reading (plus sensor error).  
**Power Requirements:** 3.6 V AA lithium metal battery, included, user replaceable.  
**Battery Life:** > 2 years.  
**Display:** 0.3" (7.6 mm) 4-digit LCD.  
**Resolution:** 0.1°C.  
**Ambient Operating Temperature:** 14 to 158°F (-10 to 70°C).  
**Storage Temperature:** -4 to 185°F (-20 to 85°C).  
**Weight:** 6.0 oz (170 g).  
**Front Panel Protection:** NEMA 4X (IP66).  
**Agency Approvals:** CE.

**MODEL CHART**

Model	Input
BPI-101	3-wire Pt100 or Ni120
BPI-102	K, J, T, N, R, S, E, or F thermocouples

# PROCESS/TEMPERATURE ALARM SWITCH MODULE

Two Form C (SPDT) Switches, Small Size, Mounts Easily on 35 mm DIN Rail

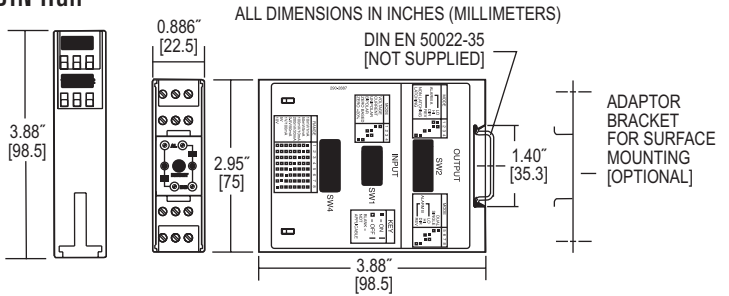

The **Series SC1 Process/Temperature Alarm Switch Module** is an on-off or limit switch with selectable process signal. Each unit has two form C (SPDT) relays which can operate independently, or be logically connected to operate as a DPDT output.

**FEATURES/BENEFITS**

- Accepts current, voltage, thermocouple, or RTD inputs
- Mounts on standard 35 mm DIN rail
- Two color LED indicator to indicate the status of each output relay
- Programmable input type, scale range, output action, and output type

**APPLICATIONS**

- Stand alone CO monitoring in parking garage
- Industrial processing equipment

MODEL CHART		
Model	Description	Power Supply
SC1090	4-20 mA, 10-50 mA, 0-20 mA, 0-10 V, -10-10 mV	85-265 VDC/VAC
SC1290	Thermocouple type J, K, R, S, T, E RTD Pt1000	85-265 VDC/VAC
SC1490	Ni100, Ni120, Cu10, Ni-Fe1000, Ni-Fe2000	85-265 VDC/VAC
SCL1090	4-20 mA, 10-50 mA, 0-20 mA, 0-10 V, -10 to 10 mV	12-24 VDC/VAC
SCL1290	Thermocouple type J, K, R, S, T, E	12-24 VDC/VAC
SCL1490	RTD Pt1000 Ni100, Ni120, Cu10, Ni-Fe1000, N-Fe2000	12-24 VDC/VAC

**SPECIFICATIONS**

**Input:** See table.  
**Power Supply:** SC models: 85-265 VDC/VAC, 50 to 400 Hz; SCL models: 12-24 VDC/VAC, 50 to 400 Hz.  
**Isolation:** 1500V rms between outputs, input, and power.  
**Set Points:** Adjustable 0 to 100% of span.  
**Deadband:** Adjustable 0.25% to 100% of span.  
**Drift:** ±0.02%/°C typical ±0.05%/°C maximum.  
**Ambient Temperature Range:** Operating: 32 to 131°F (0 to 55°C); Storage: -40 to 176°F (-40 to 80°C).  
**Excitation Current:** (SC1490) Cu10 Ω = 5 mA; Pt100 Ω, Ni100 Ω, Ni120 Ω = 500 μA; Pt500 Ω, NiFe1000 Ω = 100 μA; Pt1000 Ω = 50 μA.

**Lead Compensation Error:** (SC1490) ≈ 0.02%/Ω.  
**Open Lead Protection:** (SC1490) upscale only.  
**Input Impedance:** SC1090: Voltage input = 1 MΩ, current input = 10 Ω; SC1290: 3 MΩ.  
**Sensor Burnout Protection:** Selectable.  
**Relay Output:** Form C, SPDT, one per set point, 5A @ 250 VAC, resistive.  
**Latch Circuit Reset:** Automatic at power up. Manual with reset switch on front of module.  
**Indicators:** One dual color LED per set point. Red = relay on, green = relay off.  
**Wiring Terminals:** Screw driven compression type.

**ACCESSORIES**

Model	Description
A-360	Aluminum DIN rail 1 m

SERIES AN2

# INDICATING ALARM ANNUNCIATOR

Up to 8 Inputs, Integral Power Supply

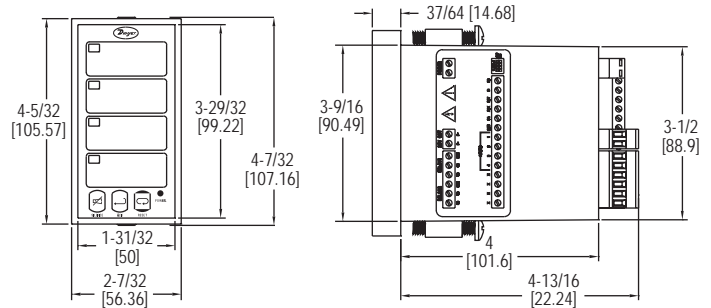

The **Series AN2 Indicating Alarm Annunciator** provides visible and audible alarms for up to eight inputs. Audible alarm conditions can be acknowledged, reset, or silenced either via the front panel push-buttons or the rear terminal block. The annunciator also has two SPDT relay outputs that can be used to initiate external alarms, buzzers, or paging devices.

**FEATURES/BENEFITS**

- Includes integral 24 VDC power supply to power most switches
- Can be set to any common ISA sequences

**APPLICATIONS**

- Water and wastewater panels
- Tank level monitoring
- Temperature monitoring process

**SPECIFICATIONS**

**Inputs:** NO or NC switches, open collector transistor (open circuit voltage = 3.3 VDC); Logic levels: LO = 0-0.9 VDC, HI = 2.4-28 VDC (100 KΩ input impedance).  
**Outputs:** Two SPDT relay (3 A @ 250 VAC or 30 VDC, resistive; 1/14 HP @ 125/250 VAC, inductive).  
**Temperature Limits:** -40 to 149°F (-40 to 65°C).  
**Power Requirements:** 85-265 VAC 50/60 Hz, 90-265 VDC; 12-36 VDC, 12-24 VAC (depending on model).  
**Power Consumption:** 20 W (6 W on low voltage models).  
**Mounting:** 1/8 DIN.  
**Housing Material:** UL rated 94V-0 high impact plastic.  
**Enclosure Rating:** NEMA 4X (IP66) front panel.  
**Weight:** 9.6 oz (272 g).  
**Agency Approvals:** CE, UL.

MODEL CHART		
Model	Number of Outputs	Power Supply
AN24-1	4	85-265 VAC
AN24-2	4	12-36 VDC
AN28-1	8	85-265 VAC
AN28-2	8	12-36 VDC



# ELECTROMECHANICAL RELAYS

## 30 Amp, SPDT and DPDT Operation



SPDT



DPDT

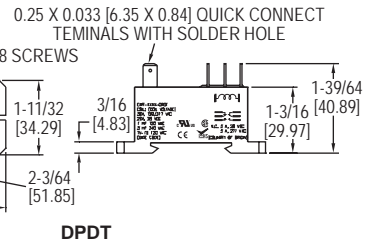
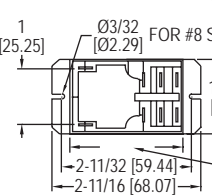
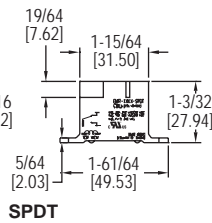
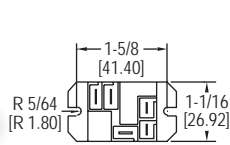

DPDT

The Series 9 Electromechanical Relays are small in size, features Class F insulation for a max coil temperature of 155°C, quick-connect terminals for simple connection, and is panel mountable. The relays are compact and impervious to shock and vibration.

### FEATURES/BENEFITS

- Compact size for flange mounting
- Quick-connect terminals to allow for easy installation

### APPLICATIONS

- Motor control
- Lighting control
- Refrigeration compressor systems

Model	Operation	Input Voltage	Coil Resistance
9AS5A5224	AC	24 VAC 50/60 Hz	500 Ω
9AS5A52120	AC	120 VAC 50/60 Hz	3000 Ω
92S11A22D24	AC	24 VAC 50/60 Hz	250 Ω
92S11A22D120	AC	120 VAC 50/60 Hz	1600 Ω
9AS5D5224	DC	24 VDC	576 Ω
92S11D22D12	DC	12 VDC	86 Ω
92S11D22D24	DC	24 VDC	1600 Ω

### SPECIFICATIONS

**Operating and Load Voltage Range:** 12-277 VAC; 5-110 VDC.  
**Electrical Connection:** Quick-connect tab terminals. SPDT 0.187" coil terminal/0.25" contact terminal; DPDT 0.25" coil terminal/0.25" contact terminal.  
**Switching Operation:** SPDT or DPDT.  
**Electrical Rating:** SPDT: NO 30 A @ 240 VAC / 28 VDC; NC 10 A @ 240 VAC / 28 VDC; DPDT: 30 A @ 240 VAC 20 A @ 28 VDC.

**Temperature Limits:** Storage: -40 to 185°F (-40 to 85°C); Operation: -40 to 131°F (-40 to 55°C).  
**Voltage Loss:** 2.5 VA (VAC); 1W (VDC).  
**Cycle Life:** 100,000 cycles (electrical); 10,000,000 cycles (mechanical).  
**Housing:** Polyester resin.  
**Weight:** 1.16 oz (45 g) (SPDT); 3 oz (85 g) (DPDT).  
**Agency Approvals:** CE, cULus, (EMR-XXXX-DPDT), cURus (EMR-XXXX-SPDT).

### ACCESSORIES

Model	Description
16-9ADIN1	Din adaptor
A-360	Aluminum DIN rail 1 m

## SERIES 781 & 782

# ICE CUBE RELAYS

## SPDT or DPDT Operation

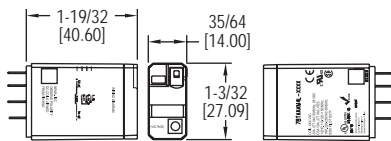

781

Pictures shown with socket accessory (sold separately)

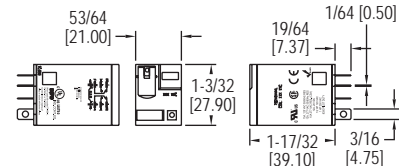

782

The Series 781 & 782 Ice Cube Relays are full-featured relays that can be used to handle loads up to 15 amps for AC or DC circuits. It features a flag status indicator and a LED status lamp to let the user know when the relay is activated. In order to differentiate between AC and DC actuated models, the push-to-test button is color coded and a removable lock-down lever holds the test button in place.

### FEATURES/BENEFITS

- Clear plastic housing to easily view the contacts
- Flag and LED status indicators for visual confirmation of relay state
- Socket mounted for quick installation/replacement

### APPLICATIONS

- Refrigeration compressor systems
- HVAC motor controls
- Water/wastewater pump control

### SPECIFICATIONS

**Operating and Load Voltage Range:** 24-240 VAC; 24 VDC.  
**Electrical Connection:** Silver alloy plug-in contacts.  
**Switching Operation:** SPDT or DPDT.  
**Electrical Rating:** Depends on model, see model chart.  
**Temperature Limits:** Storage: -40 to 185°F (-40 to 85°C); Operation: -40 to 131°F (-40 to 55°C).

**Power Consumption:** 781: 0.9 VA; 0.7W; 782: 1.2 VA; 0.9W.  
**Cycle Life:** 100,000 cycles (electrical); 10,000,000 cycles (mechanical).  
**Housing:** Plastic polycarbonate.  
**Weight:** 781: 1.02 oz (29 g); 782: 1.3 oz (36 g).  
**Agency Approvals:** CE, CSA, cULus, cURus.

### ACCESSORIES

Model	Description
70-781D5-1A	Socket for 781 series relay
70-782D8-1A	Socket for 782 series relay

Model	Operation	Input Voltage	Coil Resistance	Electrical Rating
781XAXRM4L-24A	AC	24 VAC 50/60 Hz	180 Ω	15 A @ 277 VAC (50/60 Hz) or 28 VDC
781XAXRM4L-120A	AC	120 VAC 50/60 Hz	4430 Ω	15 A @ 277 VAC (50/60 Hz) or 28 VDC
781XAXRM4L-240A	AC	240 VAC 50/60 Hz	15720 Ω	15 A @ 277 VAC (50/60 Hz) or 28 VDC
781XAXRM4L-24D	DC	24 VDC	750 Ω	15 A @ 277 VAC (50/60 Hz) or 28 VDC
782XBXM4L-24A	AC	24 VAC 50/60 Hz	180 Ω	15 A @ 120 VAC 50/60 Hz; 12 A @ 277 VAC 50/60 Hz or 28 VDC (UL); 10 A @ 277 VAC 50/60 Hz (CSA)
782XBXM4L-120A	AC	120 VAC 50/60 Hz	4430 Ω	15 A @ 120 VAC 50/60 Hz; 12 A @ 277 VAC 50/60 Hz or 28 VDC (UL); 10 A @ 277 VAC 50/60 Hz (CSA)
782XBXM4L-240A	AC	240 VAC 50/60 Hz	15720 Ω	15 A @ 120 VAC 50/60 Hz; 12 A @ 277 VAC 50/60 Hz or 28 VDC (UL); 10 A @ 277 VAC 50/60 Hz (CSA)
782XBXM4L-24D	DC	24 VDC	650 Ω	15 A @ 120 VAC 50/60 Hz; 12 A @ 277 VAC 50/60 Hz or 28 VDC (UL); 10 A @ 277 VAC 50/60 Hz (CSA)



SERIES 783 & 784



# ICE CUBE RELAYS

## 3PDT or 4PDT Operation

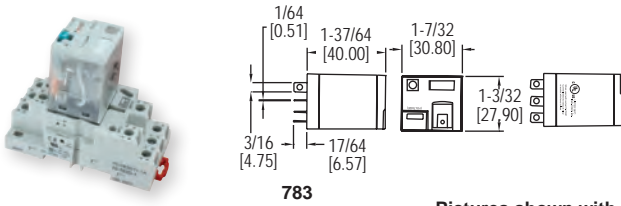

783

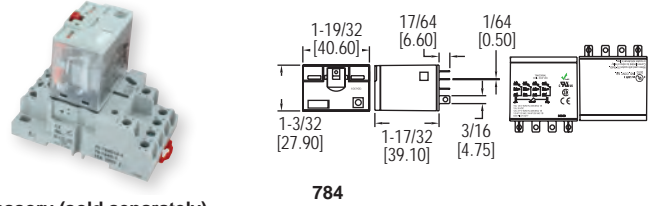

784

Pictures shown with socket accessory (sold separately)

The Series 783 & 784 Ice Cube Relays are full-featured relays that can be used to handle loads up to 15 amps for AC or DC circuits. It features a flag status indicator and a LED status lamp to let the user know when the relay is activated. In order to differentiate between AC and DC actuated models, the push-to-test button is color coded and a removable lock-down lever holds the test button in place.

**FEATURES/BENEFITS**

- Clear plastic housing to easily view the contacts
- Flag and LED status indicators for visual confirmation of relay state
- Socket mounted for quick installation/replacement

**APPLICATIONS**

- Refrigeration compressor systems
- HVAC motor controls
- Water/wastewater pump control

**SPECIFICATIONS**

**Operating and Load Voltage Range:** 24-240 VAC; 24 VDC.  
**Electrical Connection:** Silver alloy plug-in contacts.  
**Switching Operation:** 3PDT or 4PDT.  
**Electrical Rating:** 15 A @ 120 VAC 50/60 Hz; 12 A @ 277 VAC 50/60 Hz or 28 VDC.  
**Temperature Limits:** Storage: -40 to 185°F (-40 to 85°C); Operation: -40 to 131°F (-40 to 55°C).  
**Power Consumption:** 783: 1.5 VA; 1.4 W; 784: 1.5 VA; 1.5 W.  
**Cycle Life:** 100,000 cycles (electrical); 10,000,000 cycles (mechanical).  
**Housing:** Plastic polycarbonate.  
**Weight:** 783: 2.1 oz (60 g); 784: 2.8 oz (80 g).  
**Agency Approvals:** CE, CSA, cULus, cURus.

MODEL CHART			
Model	Operation	Input Voltage	Coil Resistance
783CXM4L-24A	AC	24 VAC 50/60 Hz	103 Ω
783CXM4L-120A	AC	120 VAC 50/60 Hz	2770 Ω
783CXM4L-24D	DC	24 VDC	400 Ω
784DXM4L-24A	AC	24 VAC 50/60 Hz	84.5 Ω
784DXM4L-120A	AC	120 VAC 50/60 Hz	2220 Ω
784DXM4L-24D	DC	24 VDC	388 Ω

ACCESSORIES	
Model	Description
70-783D11-1A	Socket for 783 series relay
70-784D14-1	Socket for 784 series relay
70-ASMM-24	Protection modules, MOV suppressor, 24 VAC/VDC
70-ASMM-120	Protection modules, MOV suppressor, 120 VAC/VDC
70-ASMD-250	Protection modules, protection diode, 6 to 250 VDC
16-750/788CBJ-1	Coil bus jumpers

SERIES SCS

# CURRENT SWITCHES

## Optional Relay Output, Solid or Split Core Case

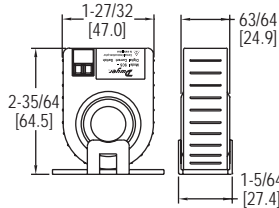

SCS-11100 and SCS-120025

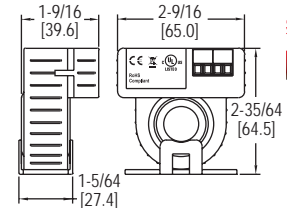

SCS-11100-R

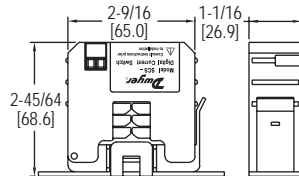

SCS-220015, SCS-220150, and SCS-21125

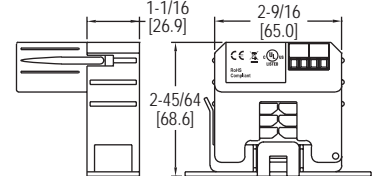

SCS-220150-R and SCS-21125-R

The Series SCS Current Switches are ideal for monitoring whether fans, pumps, or motors are operating. The current flowing through the core of the device powers the circuit without an external power supply. All models have a built in solid state output and are easy to install. Optional LED's and 10 Amp relay modules are available. The Series SCS is available in both split and solid core configurations.

**FEATURES/BENEFITS**

- Integral mounting flange for quick installation
- Solid core or split core configurations

**APPLICATIONS**

- BAS
- HVAC

**SPECIFICATIONS**

**Output:** Isolated, 1 A @ 30 VAC/DC max, NO.  
**External Relay:** SPST N.O., 10 A at 260 VAC (5 A at 30 VDC).  
**Power Requirements:** None, self-powered.  
**Temperature Limits:** 5 to 140°F (-15 to 60°C).  
**Isolation Voltage:** 600 VAC RMS.  
**Frequency:** 50/60 Hz.  
**Enclosure Rating:** UL, 94 V-0 flammability rated, ABS plastic housing.  
**Agency Approvals:** CE, cULus.

MODEL CHART											
Model	Case	Amperage Range	Set Point	Switch Mode	Snap-on Relay	Model	Case	Amperage Range	Set Point	Switch Mode	Snap-on Relay
SCS-120025	Solid	.25 to 200 A	0.25 fixed	Under	No	SCS-220150	Split	1.5 to 200 A	1.5 fixed	Under	No
SCS-11100	Solid	1 to 135 A	Adjustable	Over/under	No	SCS-21125	Split	1.25 to 135 A	Adjustable	Over/under	No
SCS-11100-R	Solid	1 to 135 A	Adjustable	Over/under	Yes	SCS-220150-R	Split	1.5 to 200 A	1.5 fixed	Under	Yes
SCS-220015	Split	.15 to 200 A	0.15 fixed	Under	No	SCS-21125-R	Split	1.25 to 135 A	Adjustable	Over/under	Yes



# MINIATURE CURRENT SWITCHES

Low Cost, Solid or No Core, LED Confirmation, Adjustable Set Point

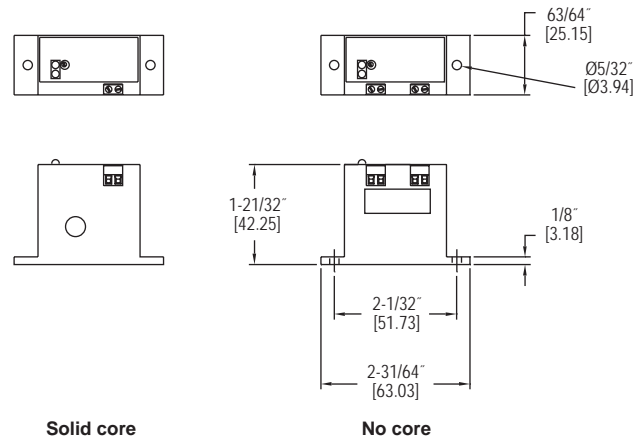

The **Series MCS Miniature Current Switches** are ideal for monitoring the current usage in fuse boxes and small control panels. Both models have adjustable set points and LED indication to show there is power to the unit and when the switch activates. Set points can be adjusted using the potentiometer next to the LED's. Due to the size of the switch, it is only offered in solid core and no core versions. The no core version has terminal blocks which can accept currents up to 1 A directly into the unit.

**FEATURES/BENEFITS**

- Integral mounting flange for quick installation
- Compact size fits in any space

**APPLICATIONS**

- BAS
- HVAC

**SPECIFICATIONS**

**Amperage Range:** MCS-111050: 0.5 to 50 A AC continuous; MCS-111001: 0.01 to 1 A AC continuous.  
**Output Rating:** Isolated, N.O. 0.3 A @ 130 V DC/AC.  
**Power Requirements:** None, self-powered.  
**Hysteresis:** 1%.  
**Response Time:** <200 ms.  
**Temperature Limits:** 32 to 122°F (0 to 50°C).  
**Humidity Limits:** 10 to 95% RH (non-condensing).  
**Enclosure Rating:** UL 94 V-0 flammability rated ABS, insulation class 600 V.  
**Weight:** 0.5 oz (14.5 g).  
**Agency Approvals:** CE, cULus.

MODEL CHART				
Model	Case	Set Point	Minimum Set Point	LED
MCS-111050	Solid core	Adjustable	0.50	Red/geen
MCS-111001	No core (terminal connection)	Adjustable	0.01	Red/geen

SERIES CCS

# CURRENT SWITCHES

Solid or Split Core, LED Visual Confirmation, Fixed or Adjustable Set Point

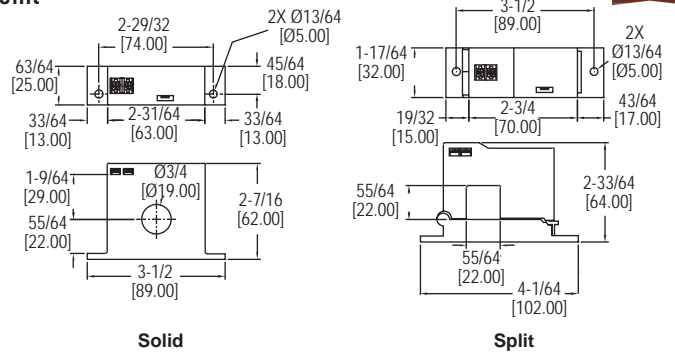

The **Series CCS Current Switches** are ideal for monitoring the operating status of fans, pumps, and motors. These self-powered switches can be hung or tied directly to cables or wires. For use on existing installations, split core models can be installed without disconnecting cables. LED indicators provide a visual confirmation that the current is flowing through the core. Both fixed and adjustable set points are available. The adjustable models utilize a potentiometer to easily adjust the set point.

**FEATURES/BENEFITS**

- Integral mounting flange for quick installation
- Solid core or split core configurations
- LED Indicator

**APPLICATIONS**

- BAS
- HVAC

**SPECIFICATIONS**

**Amperage Range:** 0 to 200 A AC.  
**Maximum Switch Rating:** For dry contact models: 0.3 A @ 135 VAC/DC; For non-dry contact models: 1 A @ 240 VAC.  
**Power Requirements:** None, self-powered.  
**Temperature Limits:** -22 to 158°F (-30 to 70°C).  
**Humidity Limits:** 0 to 95% (non-condensing).  
**Isolation Voltage:** 2000 V.  
**Frequency:** 40 to 400 Hz.  
**Enclosure Rating:** UL 94 V-0 flammability rated, ABS plastic housing.  
**Agency Approvals:** CE, cULus.

MODEL CHART					
Model	Case	Set Point	Minimum Set Point (A)	LED	Dry Contact Output
CCS-121050	Solid core	Fixed	0.50 (±0.2)	Red	Yes
CCS-111100	Solid core	Adjustable	1.00 (±0.2)	Red/green	No
CCS-221100	Split core	Fixed	1.00 (±0.2)	Red	Yes
CCS-211150	Split core	Adjustable	1.50 (±0.2)	Red/green	No
CCS-131100	Solid core	Adjustable	1.00 (±0.2)	Red/green	Yes
CCS-231150	Split core	Adjustable	1.50 (±0.2)	Red/green	Yes



**MODEL MSCS**

# MINIATURE CURRENT SWITCHES

Split Core, Integral Mounting Tabs

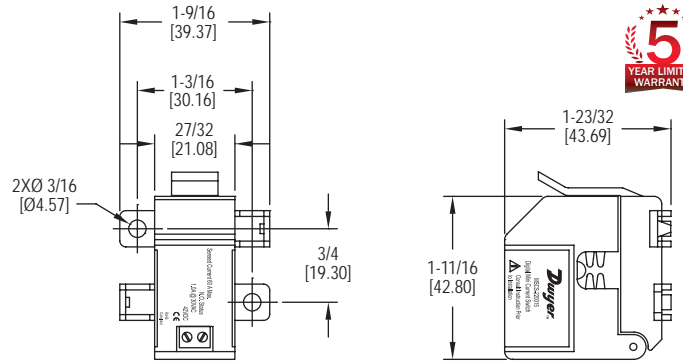

The **Model MSCS Miniature Current Switches** are low cost solutions for monitoring on and off status of light to medium current loads in compact spaces. This unit has a split core design and has a fixed set point of 0.15 amps. It is designed to detect changes in operating current to prevent motor belt loss, slippage, or mechanical failure.

**FEATURES/BENEFITS**

- Integral mounting flange for quick installation
- Compact size fits in any space

**APPLICATIONS**

- BAS
- HVAC
- Small industrial motors

MODEL CHART	
Model	Motor Application
MSCS-220015	Miniature split core current switch

SPECIFICATIONS	
<b>Amperage Range:</b>	0.15 to 60 A.
<b>Output:</b>	NO.
<b>Power Requirements:</b>	None, self-powered.
<b>Temperature Limits:</b>	5 to 140°F (-15 to 60°C).
<b>Humidity Limits:</b>	0 to 95%, non-condensing.
<b>Isolation Voltage:</b>	300 VAC RMS.
<b>Frequency:</b>	50/60 Hz.
<b>Enclosure Rating:</b>	UL 94 V-0 flammability rated, ABS plastic housing.
<b>Agency Approvals:</b>	CE, cULus.

**SERIES SSCS**

# SURE-SET CURRENT SWITCHES

Split Core, Adjustable Set Point

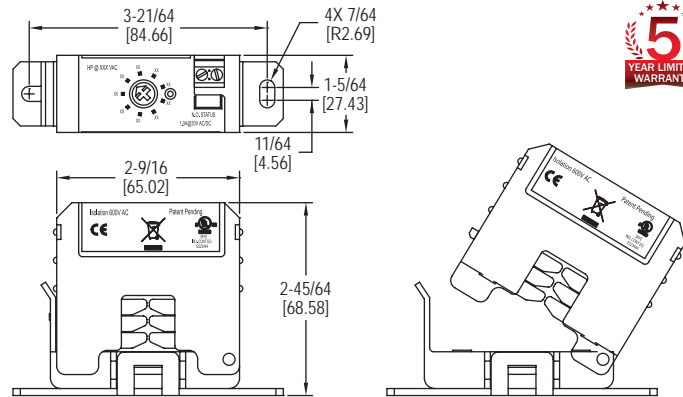

The **Series SSCS Sure-Set Current Switches** provide a unique approach to calibration and installing current sensors in a low cost, fast, and accurate design. Selecting the set point has never been easier, with each model having 9 pre-configured adjustable HP set points. This feature eliminates the need to work within a live enclosure, reducing the risk of arc flash on installation.

**FEATURES/BENEFITS**

- Models for 230 VAC or 480 VAC applications
- Low and high motor HP ranges available
- 9 pre-set HP set points for faster installation

**APPLICATIONS**

- BAS
- HVAC
- Industrial motors

MODEL CHART			
Model	Case	Motor HP Range	Motor Application
SSCS-211100-230	Split	1, 2, 3, 5, 7.5, 10, 15, 20, 25	230 VAC
SSCS-211200-480	Split	2, 3, 5, 7.5, 10, 15, 20, 25, 30	480 VAC
SSCS-211500-230	Split	5, 7.5, 10, 15, 20, 25, 30, 40, 50	230 VAC
SSCS-211150-480	Split	15, 20, 25, 30, 40, 50, 60, 75, 100	480 VAC

SPECIFICATIONS	
<b>Output:</b>	Isolated, NO.
<b>Power Requirements:</b>	None, self-powered.
<b>Temperature Limits:</b>	5 to 140°F (-15 to 60°C).
<b>Humidity Limits:</b>	0 to 95%, non-condensing.
<b>Isolation Voltage:</b>	600 VAC RMS.
<b>Frequency:</b>	50/60 Hz.
<b>Enclosure Rating:</b>	UL 94 V-0 flammability rated, ABS plastic housing.
<b>Agency Approvals:</b>	CE, cULus.

ACCESSORIES	
Model	Description
SCT-RLY-12	12 VAC trigger voltage relay module
SCT-RLY-24	24 VAC trigger voltage relay module

# CURRENT TRANSFORMERS

Solid or Split Core, Field Selectable Range

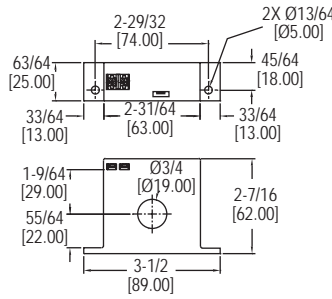

Solid

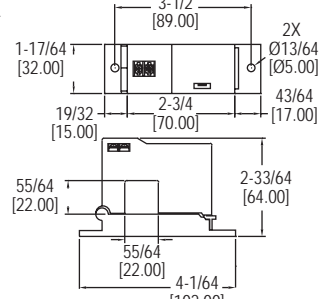

Split

The Series CCT40/50 Current Transformers are a low cost alternative for measuring power and monitoring the operation of fans, pumps, or other equipment. For use on existing installations, split core models can be installed without disconnecting cables. Each model offers three jumper selectable ranges and a choice of three different outputs.

Model	Range	Output	Power Requirements	Case
CCT40-202	10/20/50 A	0-5 V	Self-powered	Solid core
CCT50-202	100/150/200 A	0-5 V	Self-powered	Solid core
CCT40-102	10/20/50 A	0-5 V	Self-powered	Split core
CCT50-102	100/150/200 A	0-5 V	Self-powered	Split core
CCT40-203	10/20/50 A	0-10 V	Self-powered	Solid core
CCT50-203	100/150/200 A	0-10 V	Self-powered	Solid core
CCT40-200	10/20/50 A	4-20 mA	15 to 42 VDC, loop powered	Solid core
CCT50-200	100/150/200 A	4-20 mA	15 to 42 VDC, loop powered	Solid core
CCT40-100	10/20/50 A	4-20 mA	15 to 42 VDC, loop powered	Split core
CCT50-100	100/150/200 A	4-20 mA	15 to 42 VDC, loop powered	Split core

### SPECIFICATIONS

**Amperage Range:** Field selectable; up to 200 A (depending on model).  
**Output:** 0-5 V, 0-10 V, or 4-20 mA (depending on model).  
**Power Requirements:** Self-powered or 15-42 VDC loop powered (depending on model).  
**Accuracy:** 1%.  
**Temperature Limits:** -22 to 158°F (-30 to 70°C).  
**Humidity Limits:** 0 to 95% (non-condensing).  
**Response Time:** 250 ms to 90%.  
**Isolation Voltage:** 2000 V.  
**Frequency:** 10 to 400 Hz.  
**Enclosure Rating:** UL 94 V-0 flammability rated, ABS plastic housing.  
**Agency Approvals:** CE, cULus.

### FEATURES/BENEFITS

- Integral mounting flange for quick installation
- Solid core or split core configurations
- Jumper selectable range

### APPLICATIONS

- BAS
- HVAC



# TRUE RMS CURRENT TRANSFORMERS

Solid or Split Core, Field Selectable Range

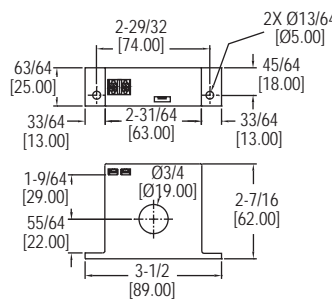

Solid

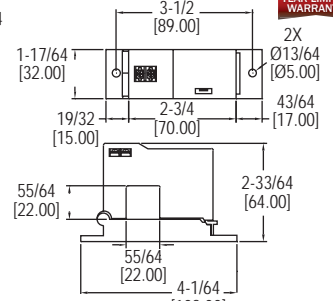

Split

The Series CCT60/70 True RMS Current Transformers are a low cost alternative for providing true RMS outputs on distorted AC waveforms. True RMS outputs are ideal for nonlinear loads or noisy circuits. For existing installations, split core models can be installed without disconnecting cables. Each model offers three jumper selectable ranges to reduce the risk of ordering the wrong model.

### FEATURES/BENEFITS

- Integral mounting flange for quick installation
- Solid core or split core configurations
- Jumper selectable range
- True RMS

### APPLICATIONS

- BAS
- HVAC

Model	Range	Case
CCT60-200	10/20/50 A	Solid core
CCT70-200	100/150/200 A	Solid core
CCT60-100	10/20/50 A	Split core
CCT70-100	100/150/200 A	Split core

### SPECIFICATIONS

**Amperage Range:** Up to 200 A (depending on model).  
**Output:** 4-20 mA, true RMS.  
**Power Requirements:** 24 VDC nominal.  
**Accuracy:** 1%.  
**Temperature Limits:** -22 to 158°F (-30 to 70°C).  
**Humidity Limits:** 0 to 95% (non-condensing).  
**Response Time:** 250 ms to 90%.  
**Isolation Voltage:** 2000 V.  
**Frequency:** 10 to 400 Hz.  
**Enclosure Rating:** UL 94 V-0 flammability rated, ABS plastic housing.  
**Agency Approvals:** CE, cULus.



# AC POWER TRANSFORMERS

20 VA to 150 VA, Single or Dual Hub, Circuit Breaker, UL Class 2



APT-40-3SN



APT-50-5DB



APT-50-5SB

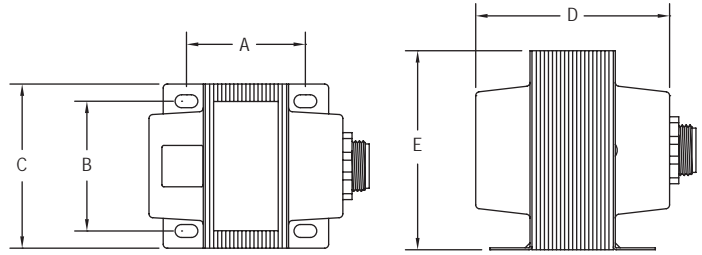

Model	Dimensions in [mm]				
	A	B	C	D	E
APT-20-0SN	1-31/64 (37.6)	1-21/32 (41.9)	1-7/8 (47.5)	2-17/64 (57.4)	2-39/64 (66.2)
APT-20-1SN	1-31/64 (37.6)	1-21/32 (41.9)	1-7/8 (47.5)	2-17/64 (57.4)	2-39/64 (66.2)
APT-40-3SN	1-61/64 (49.5)	1-25/32 (45.2)	2-11/64 (55.0)	2-43/64 (68.0)	2-7/8 (73.0)
APT-40-5DN	1-61/64 (49.5)	1-25/32 (45.2)	2-11/64 (55.0)	2-3/4 (70.0)	2-7/8 (73.0)
APT-50-5SB	1-13/16 (46.0)	1-31/32 (50.2)	2-1/2 (63.5)	3-7/16 (87.1)	3-1/32 (77.0)
APT-50-5DB	1-13/16 (46.0)	1-31/32 (50.2)	2-1/2 (63.5)	3-7/16 (87.1)	3-1/32 (77.0)
APT-75-5SB	2-13/64 (56.0)	1-31/32 (50.2)	2-1/2 (63.5)	3-53/64 (97.1)	3-1/32 (77.0)
APT-75-5DB	2-13/64 (56.0)	1-31/32 (50.2)	2-1/2 (63.5)	3-53/64 (97.1)	3-1/32 (77.0)
APT-100-5SB	2-39/64 (66.0)	1-31/32 (50.2)	2-1/2 (63.5)	4-1/4 (107.1)	3-1/32 (77.0)
APT-100-5DB	2-39/64 (66.0)	1-31/32 (50.2)	2-1/2 (63.5)	4-1/4 (107.1)	3-1/32 (77.0)
APT-150-1DB	2-33/64 (64.0)	1-31/32 (50.2)	2-1/2 (63.5)	3-9/16 (90.5)	3-1/32 (77.0)

The **Series APT AC Power Transformers** provide isolated step-down to 24 VAC with models offering VA ratings of 20, 40, 50, 75, 96, or 150 VA's. These cost efficient transformers are offered in single or dual 1/2" NPT threaded hub mounts with 8-1/2" 18 AWG wire leads, to meet the installation requirements of a variety of building automation and control panel applications in HVAC. All models are UL Class 2 listed.

**FEATURES/BENEFITS**

- Single or dual 1/2" NPT
- Universal supply voltage input
- With or without integral circuit breaker

**APPLICATIONS**

- BAS
- HVAC

**SPECIFICATIONS**

**Input Voltage:** See model chart.  
**Input Frequency:** 50/60 Hz.  
**Output Voltage:** See model chart.  
**Output VA Rating:** 20, 40, 50, 75, 96, or 150 VA.  
**Mounting:** Slotted foot mount with single, or dual 1/2" NPT hub.  
**Current Protection:** See model chart.  
**Electrical Connections:** Models ending in -20: 20" (508 mm) 18 AWG leads; All other models: 8.5" (210 mm) 18 AWG leads.  
**Weight:** See model chart.  
**Agency Approvals:** CE, cULus.

**MODEL CHART**

Model	Rating	Input Voltage	Output Voltage	Mounting	Current Protection	Wiring	Weight
APT-20-0SN	20 VA	24 VAC	24 VAC	Foot mount with single hub	Inherent	Diagram B	1.25 lb (0.57 kg)
APT-20-1SN	20 VA	120 VAC	24 VAC	Foot mount with single hub	Inherent	Diagram A	1.29 lb (0.59 kg)
APT-40-3SN	40 VA	120/208/240/277 VAC	24 VAC	Foot mount with single hub	Internal fuse	Diagram D	2.07 lb (0.94 kg)
APT-40-5DN	40 VA	120/208/240/277/480 VAC	24 VAC	Foot mount with dual hub	Internal fuse	Diagram C	2.29 lb (1.04 kg)
APT-50-5SB	50 VA	120/208/240/277/480 VAC	24 VAC	Foot mount with single hub	Button circuit breaker	Diagram C	2.69 lb (1.22 kg)
APT-50-5DB	50 VA	120/208/240/277/480 VAC	24 VAC	Foot mount with dual hub	Button circuit breaker	Diagram C	2.73 lb (1.24 kg)
APT-75-5SB	75 VA	120/208/240/277/480 VAC	24 VAC	Foot mount with single hub	Button circuit breaker	Diagram C	3.60 lb (1.63 kg)
APT-75-5DB	75 VA	120/208/240/277/480 VAC	24 VAC	Foot mount with dual hub	Button circuit breaker	Diagram C	3.62 lb (1.64 kg)
APT-100-5SB	100 VA	120/208/240/277/480 VAC	24 VAC	Foot mount with single hub	Button circuit breaker	Diagram C	4.03 lb (1.83 kg)
APT-100-5DB	100 VA	120/208/240/277/480 VAC	24 VAC	Foot mount with dual hub	Button circuit breaker	Diagram C	4.05 lb (1.84 kg)
APT-150-1DB	150 VA	120 VAC	24 VAC	Foot mount with dual hub	Button circuit breaker	Diagram A	4.98 lb (2.26 kg)

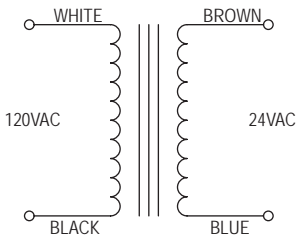

Diagram A

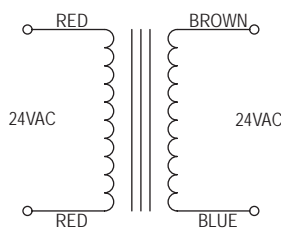

Diagram B

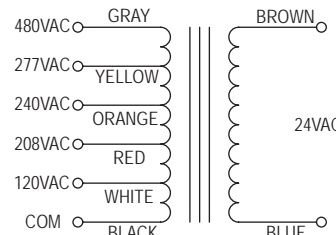

Diagram C

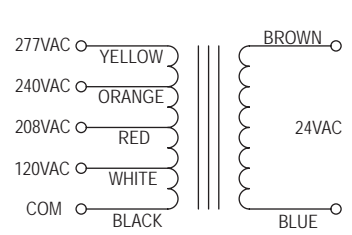
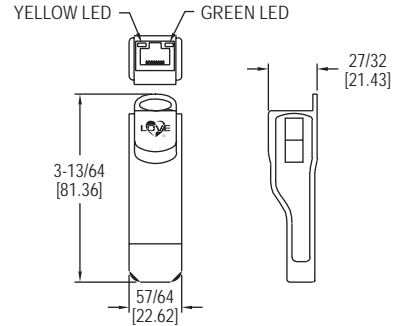

Diagram D



# MINI-NODE™ COMMUNICATION SIGNAL CONVERTER

Converts RS-485 to USB, Integral USB Connector, No External Power



The **Model MN-1 Mini-Node™ Communication Signal Converter** is a low cost device that converts half duplex RS-485 serial communications signals into a signal that can be read by any computer with a USB port. The integral USB connector and RJ-45 connector reduces set up time by eliminating extra wiring. The Model MN-1 is powered via the USB connection which eliminates the need for an external power source. The compact size is great for field installation, control panels, and lab testing.

**FEATURES/BENEFITS**

- Converts half duplex RS-485 via USB port
- Reduces set up time of process controllers

**APPLICATIONS**

- Oven, boiler, or chiller control
- Hot plates/melt pots
- Packaging equipment
- Environmental chambers
- Medical equipment
- Food service equipment

**SPECIFICATIONS**

**Power Requirements:** No external power required.  
**Power Consumption:** 0.4 W.  
**Isolated Voltage:** 3000 VDC.  
**Input Impedance:** 96 kΩ.  
**USB Connector:** B-type (female).  
**RS-485 Connector:** RJ-45.  
**Baud Rate:** 75, 150, 300, 600, 1200, 2400, 4800, 9600, 19200, 38400, 57600, and 115200 bps.  
**Compatibility:** Full compliance with USB V.2.0 specification.  
**Agency Approvals:** CE.

**MODEL CHART**

Model	Description
MN-1	Mini-Node™ USB to RS-485 converter

**SERIES A-700**

# POWER SUPPLY

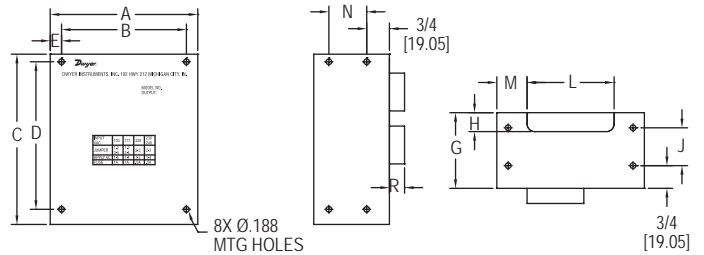

Dim.	0.5 amp	2.4 amp	4.8 amp	Dim.	0.5 amp	2.4 amp	4.8 amp	Dim.	0.5 amp	2.4 amp	4.8 amp
A	4 [101.6]	4-7/8 [123.83]	9 [228.6]	E	25/64 [9.92]	1/4 [6.35]	1/2 [12.7]	L	17/64 [14.68]	2-55/64 [72.63]	-
B	3-3/8 [85.73]	4-1/8 [104.78]	8 [203.2]	G	1-5/8 [41.28]	2-1/2 [63.5]	2-3/4 [69.85]	M	51/64 [20.24]	1-1/32 [26.19]	-
C	4-7/8 [123.84]	5-5/8 [142.88]	4-7/8 [123.83]	H	37/64 [14.68]	43/64 [17.07]	-	N	-	1-1/4 [31.75]	1-1/4 [31.75]
D	4-1/8 [104.78]	4-7/8 [123.83]	4-1/8 [104.78]	J	-	1-1/4 [31.75]	1-1/4 [31.75]	R	29/64 [11.51]	29.64 [11.51]	17/32 [13.49]

The economical and reliable **Series A-700 Power Supply** is suitable for powering all Dwyer pressure, temperature or air velocity transmitters. Inexpensive, open-frame design allows convenient access to input/output solder terminals. Auxiliary inputs are selectable for operation from power sources found worldwide. Compact size eases enclosure installations.

**FEATURES/BENEFITS**

- Universal supply voltage input
- Compact size

**APPLICATIONS**

- BAS
- HVAC

**SPECIFICATIONS**

**AC Input:** 100/120/220/230-240 VAC ±10%, 47-63 Hz.  
**DC Output:** 24-28 VDC regulated.  
**Maximum Current Output:** A-700: 0.5 A @ 60 Hz, 0.45 A @ 50 Hz; A-700-2: 2 A @ 60 Hz, 1.8 A @ 50 Hz; A-700-3: 4.8 A @ 60 Hz, 4.5 A @ 50 Hz.  
**Operating Temperature:** 32 to 122°F (0 to 50°C).  
**External Fuse Required:** 0.5 A for 100-120 VAC, 0.25 A for 220-240 VAC.  
**Dimensions:** 4-7/8"H x 4"W x 1-5/8"D.  
**Weight:** 2 lb.

**MODEL CHART**

Model	Description
A-700	0.5 A
A-700-2	2 A
A-700-4	4.8 A



**MODEL BPS-005**

# LOW COST DC POWER SUPPLY

Regulated 0.5 A, 1 A Fuse Protection

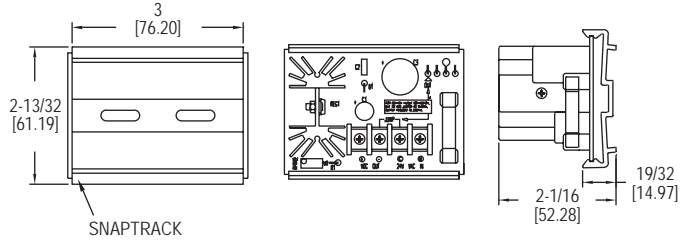

The **Model BPS-005 Low Cost DC Power Supply** is a regulated .5 A power supply that accepts 24 VAC input and provides an adjustable 1.5 to 29 VDC output. Output voltage adjustments are made using the on-board potentiometer while measuring the output with a multimeter. A compact snap track design allows the power supply to be surface mounted within a panel.

**FEATURES/BENEFITS**

- Snap track design allowing for easy panel installation
- Regulated 0.5 Amp

**APPLICATIONS**

- BAS
- HVAC

**SPECIFICATIONS**

**Input:** 24 VAC/VDC 50/60 Hz.  
**Output:** 24 VDC (full wave rectified and regulated) adjustable 1.5-29 VDC, 0.5 A max.  
**Maximum Current Output:** 0.5 A.  
**Over-Current Protection:** 1 A fuse.  
**Operating Temperature:** 32 to 130°F (0 to 55°C).

**Humidity Limits:** 95% (non-condensing).  
**Weight:** 0.4 lb.  
**Agency Approvals:** Meets the technical requirements of EU Directive 2011/65/ EU (RoHS II).

**MODEL CHART**

Model	Description
BPS-005	Low cost DC power supply

**MODEL BPS-015**

# LOW COST DC POWER SUPPLY

Regulated 1.5 A, 3 A Fuse Protection

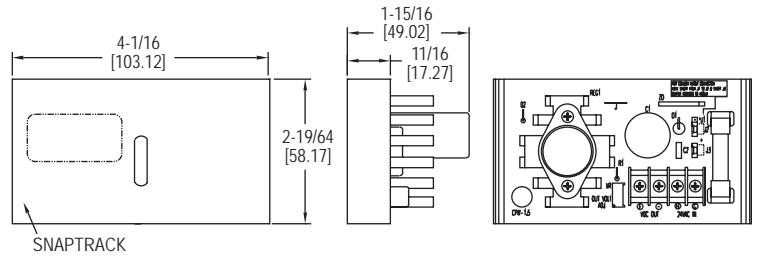

The **Model BPS-015 Low Cost DS Power Supply** is used to convert 24 VAC to a regulated DC power source for transmitters with 4 to 20 mA outputs. The output voltage can be field adjusted from 1.5 V to 27 V using a potentiometer. The 3 A fuse protects the power supply from over-current conditions. The snap-on bracket can be quickly surface mounted to any flat surface.

**FEATURES/BENEFITS**

- Snap track design allowing for easy panel installation
- Regulated 1.5 Amp

**APPLICATIONS**

- BAS
- HVAC

**SPECIFICATIONS**

**Input:** 24 VAC/VDC 50/60 Hz.  
**Output:** 24 VDC (full wave rectified and regulated) adjustable 1.5-27 VDC.  
**Maximum Current Output:** 1.5 A (de-rated to 400 mA for non-isolated circuits).

**Temperature Limits:** 32 to 130°F (0 to 55°C).  
**Humidity Limits:** 95% (non-condensing).  
**Weight:** 0.4 lb.

**MODEL CHART**

Model	Description
BPS-015	Power supply

**MODEL SCD-PS**

# DIN RAIL MOUNT DC POWER SUPPLY

Regulated 1 A, 24 VDC Output

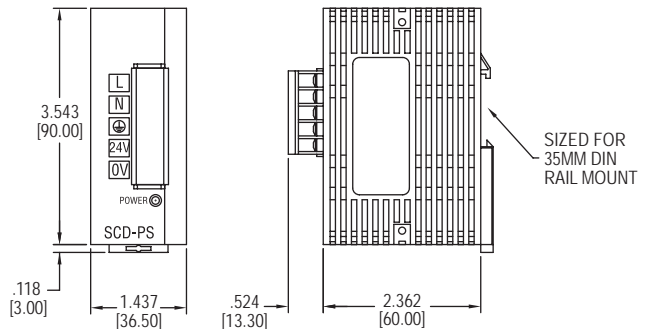

The **Model SCD-PS DIN Rail Mount DC Power Supply** is a compact and economical solution for providing DC power to any Dwyer pressure, humidity, temperature, level or air velocity transmitters. Input voltage can range from 100 to 240 VAC, 50/60 Hz without any jumpers or dip switch selections. A plastic cover slides over the terminals in order to prevent shock from accidental touching of high voltage wires.

**FEATURES/BENEFITS**

- DIN rail mount
- Universal supply voltage input

**APPLICATIONS**

- BAS
- HVAC

**SPECIFICATIONS**

**AC Input:** 100-240 VAC, 50/60 Hz.  
**DC Output:** 24 VDC (±3% VDC).  
**Maximum Current Output:** 1 A.  
**Noise:** Under 100 mVp-p typical at full load.

**Temperature Limits:** 32 to 131°F (0 to 55°C).  
**Weight:** 5.6 oz (158 g).  
**Agency Approvals:** CE, cULus.

**MODEL CHART**

Model	Description
SCD-PS	DIN rail DC power supply



# ELECTRONIC FAN SPEED CONTROL

Low Cost, 0-10 VDC Input, Selectable Hard Start

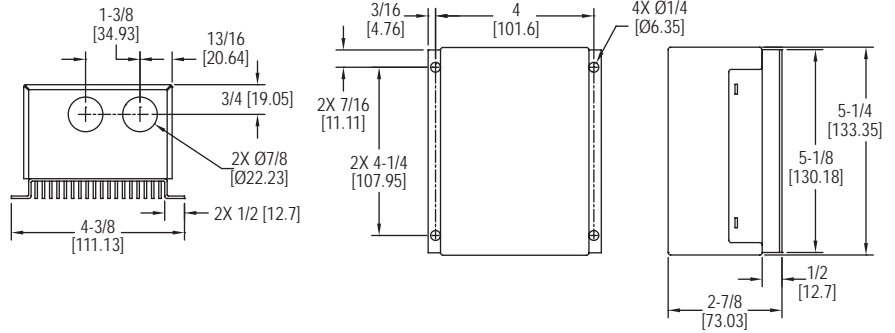

The **Model FC-1000 Electronic Fan Speed Control** provides precise speed modulation of small AC motors. Popular 0-10 VDC input works with most process controllers, eliminating the need for more expensive dampers, damper actuators, and linkages while improving overall energy efficiency of the system. This inexpensive unit enables variable control ventilation fans, condenser fans, and interfacing with VAV box controllers.

**FEATURES/BENEFITS**

- Compact design allows for use in most areas
- Improves energy efficiency in systems

**APPLICATIONS**

- Monitoring fans and motors

MODEL CHART	
Model	Description
FC-1000	Electronic fan speed control

**SPECIFICATIONS**

**Line Voltage Range:** 120-277 VAC, 60 Hz.  
**Input Signal Voltage:** 0-10 VDC.  
**Low Voltage Input:** 24 VAC, class 2.  
**Input Signal Impedance:** 10K Ω.  
**Full Load Amp Rating:** 9.8 @ 120 VAC, 9.3 @ 208 VAC, 8.0 @ 240 VAC, 6.9 @ 277 VAC.  
**Locked Rotor Amp Rating:** 24.0.  
**Temperature Limits:** -40 to 131°F (-40 to 55°C).  
**Electrical Connections:** Line voltage: 10-32 screw terminals. Signal and low voltage input: 1/4" quick connects.  
**Transient Protection:** 320 V surge suppression. Exceeds IEEE C62.41 standards.  
**Housing Materials:** Cold rolled steel.  
**Enclosure Rating:** NEMA 1.  
**Mounting:** Vertical only; four holes provided for #10 screws.  
**Weight:** 1 lb 11 oz (.77 kg).  
**Agency Approvals:** UR.

MODEL VBT-1

# VIBRATION TRANSMITTER

Continuous 4-20 mA Output Signal

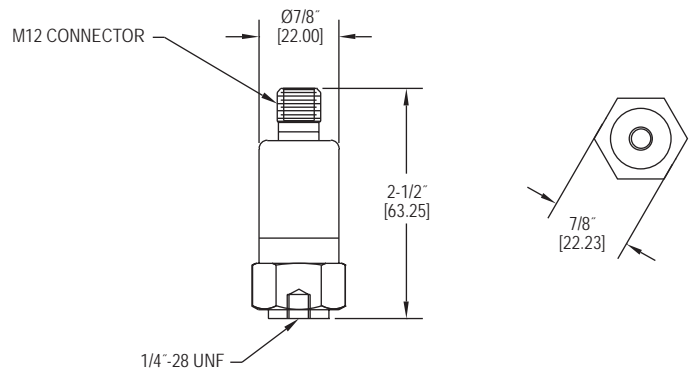

The **Model VBT-1 Vibration Transmitter** continuously detects the vibration in a system and monitors for unusual operating conditions and potential failure. The vibration is converted into an analog signal at the current output. The 2-wire loop power operation, combined with standard M12 micro cable connector and interchangeable mounting studs, make for a fast and reliable installation.

**FEATURES/BENEFITS**

- Easy set-up and operating concept
- Stainless steel housing
- No software required

**APPLICATIONS**

Vibration monitoring for:

- Motors
- Pumps
- Fans
- Engines
- Compressors
- Gear boxes

**SPECIFICATIONS**

**Housing Material:** 316 SS.  
**Temperature Limit:** -22 to 221°F (-30 to 105°C).  
**Accuracy:** < ±3%.  
**Connections:** M12 connector.  
**Enclosure Rating:** NEMA 6 (IP68).  
**Electrical Rating:** 9.6 to 32 VDC.  
**Mounting Orientation:** Any position.  
**Nonlinearity:** < ±0.25% of span.  
**Frequency Range:** 10 to 1000 Hz.  
**Output Signal:** 4-20 mA.  
**Repeatability:** < 0.5%.  
**Weight:** 0.28 lb (0.125 kg).  
**Agency Approvals:** CE.

MODEL CHART	
Model	Description
VBT-1	Vibration transmitter

ACCESSORIES	
Model	Description
A-283	4 Wire Connector



# DIGITAL TIMER/TACHOMETER/COUNTER

## 3 Controls in 1 Device, DIP Switch Configuration

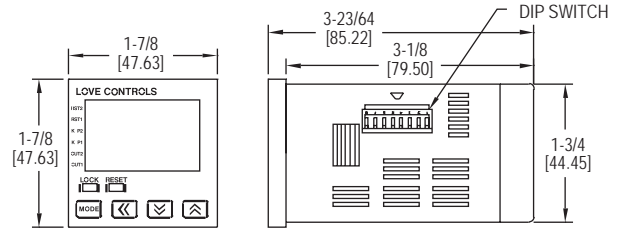

The **Series LCT216 Digital Timer/Tachometer/Counter** combines a versatile timer, counter, and tachometer all in one device. The bright, easy-to-read display shows the desired set point and the current process value as well as the operating mode that the control is functioning in. For quick set up, many of the programming parameters can be set with external dip switches located on the side of the unit.

### FEATURES/BENEFITS

- Fourteen pre-programmed timer functions
- One stage, two stage, batch, total, and dual counting modes

### APPLICATIONS

- Industrial ovens
- Batch counting in conveyor systems
- Silk screening equipment

MODEL CHART	
Model	Output Type
LCT216-100	Transistor
LCT216-110	Relay

### SPECIFICATIONS

**Operating Temperature Range:** 32 to 122°F (0 to 50°C).  
**Humidity Conditions:** 35 to 85% RH (non-condensing).  
**Control Output Ratings:** (Out 1) Relay: SPST 5 A at 250 VAC; Transistor: NPN open collector 100 mA / 30 VDC residual voltage = 1.5 VDC max; (Out 2) Relay: SPST 5 A at 250 VAC, Transistor: NPN open collector 100 mA / 30 VDC residual voltage = 1.5 VDC max.  
**Weight:** 4 oz (114 g).  
**Reset Time:** 0.001 s minimum.  
**Inputs:** Dry contact, PNP, or NPN.  
**Timing Functions:** 14 pre-programmed timing functions.  
**Supply Voltage:** 100 to 240 VAC 50 / 60 Hz.  
**Power Consumption:** Less than 10 VA.  
**Internal Power Supply:** 12 VDC ±10%, 100 mA.  
**Display:** Two-line 6 digit negative transmissive LCD display.  
**Agency Approvals:** CE, cULus.

# COUNT DOWN DIGITAL TIMER

## Quick Installation, Digital Input, Audible Alarm

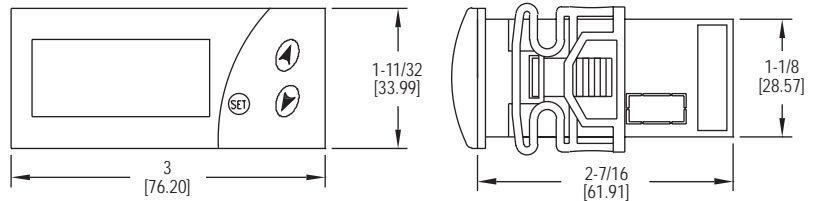

The **Series LCT316 Count Down Digital Timer** provides accurate countdown timing for a variety of applications. The timer can be triggered remotely using the digital input terminals or locally via the set button. Time intervals can be set up to 999 minutes or seconds and an internal buzzer will sound when the time interval has expired.

### FEATURES/BENEFITS

- 1 second to 999 minute field set time interval
- Audible alarm for status indication

### APPLICATIONS

- Commercial cooking equipment
- Commercial dish washers and refrigeration equipment

MODEL CHART	
Model	Supply Power
LCT316-100	115 VAC
LCT316-200	230 VAC
LCT316-300	12 VAC/DC
LCT316-400	24 VAC/DC

### SPECIFICATIONS

**Operating Temperature Range:** 32 to 158°F (0 to 70°C).  
**Control Output Ratings:** Relay, SPST NO, 16 A at 250 VAC resistive.  
**Weight:** 5.6 oz (158.8 g).  
**Status Light:** LED shows time and operation.  
**Inputs:** Digital input for start and reset.  
**Supply Voltage:** 115 VAC, 230 VAC, 12 VAC/DC, 24 VAC/DC depending on model.  
**Power Consumption:** 4 VA.  
**Agency Approvals:** CE, cURus.



# ZENER BARRIERS

Intrinsically Safe Barriers for Hazardous Locations



MTL7787

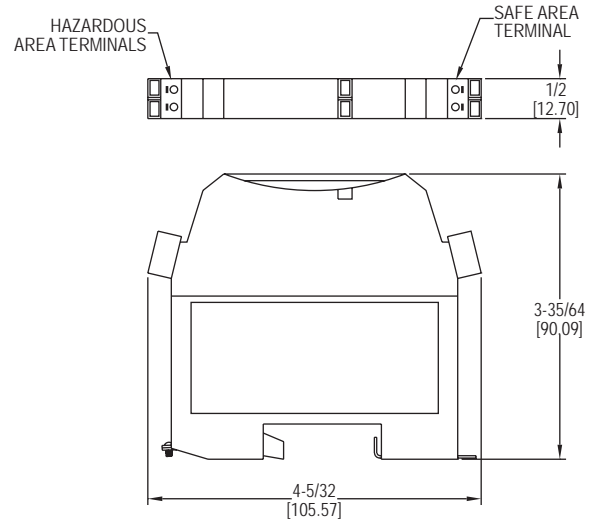

The **Series MTL7706/7787 Zener Barriers** are an intrinsically safe shunt-diode barrier that can be used to communicate with and provide isolations for certain Dwyer® transmitters approved for use in hazardous areas. These barriers limit the amount of energy allowed to pass into the hazardous area, which inhibit ignition in flammable atmospheres.

**FEATURES/BENEFITS**

- Approved for use in hazardous areas

**APPLICATIONS**

- Electrically isolates pressure and level transmitters from unregulated circuits for intrinsically safe applications

COMPATIBLE MODELS: 637, 608, SBLTX, PBLTX, IS626		
Model	Approval	Dwyer Series
MTL7706	UL for class I; div. 1 groups A, B, C, D CL II; div. 1 groups E, F, G; CL III div. 1	IS626, SBLTX, PBLTX
MTL7706	FM for class I, II, III; div. 1 groups B, C, D, E, F, G	637
MTL7706	FM for class I, II, III; div. 1 groups A, B, C, D, E, F, G	608

**Note:** Compatible models: 637, 608, SBLTX, PBLTX, IS626

MODEL CHART						
Model	FM			BASEEFA (ATEX)		
	Group	µF	mH	Group	µF	mH
MTL7706	A & B	0.083	4.2	IIC	0.083	4.2
MTL7787	A & B	0.083	3.05	IIC	0.083	3.05

Region (Authority)	Standard	Approved For	Certificate/ File no.
USA (FM) (UL)	3600, 3610 entity 3611, 3810 UL698, UL913 UL1604	AIS/I,II,III/1/Entity ABCDEFG- SCI-942; NI/I/@/ABCD/T4 [I/O] AEx[ia]IIC-SCI-942 Entity; NI/1/2/IIC/T4; Ta=140°F (60°C)	3010737
Canada (CSA)	CAN/CSA E60070, IEC60079, C22.2	Class I, Div.2, Gps A, B, C, D; Ex nA [ia] IIC T4 Class I, Xone 2, Aex nA IIC T4	1345550
UK (BASEEFA)	EN 50014, EN 50020	EEx ia IIC	BAS01ATEX7217
UK (BASEEFA) Systems	EN 50039	EEx ia IIC	Ex01E2219

**SPECIFICATIONS**

**Transmitter Voltage:** 16.2 V at 20 mA with 250 Ω load (negative w.r.t. earth); 11.0 V at 20 mA with 500 Ω load (negative w.r.t. earth).

**Safe Area Output:** 4-20 mA.

**Load Resistance:** 0 to 500 Ω.

**Power Requirement:** 20-35 VDC w.r.t. earth.

**Accuracy:** ±2 µA under all conditions.

**LED Indicator:** Green: Power indication.

**Temperature Limits:** Operating: -4 to 140°F (-20 to 60°C); Storage: -40 to 176°F (-40 to 80°C).

**Humidity:** 5 to 95% RH.

**Terminals:** Accommodate up to 2.5 mm2 stranded or single-core.

**Safety Description:** 28 µV, 300 Ω, 93 mA.

**Weight:** 4.9 oz (140 g).

**Agency Approvals:** See table.

MODEL CHART	
Model	Description
MTL7706	Zener barrier
MTL7787	Zener barrier

ACCESSORIES	
Model	Description
A-360	Aluminum DIN rail 1 m

# GALVANIC BARRIER

## Intrinsically Safe Isolators for Hazardous Locations

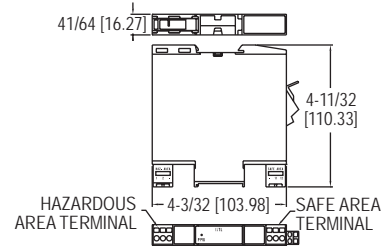

The **Series MTL5541 Galvanic Barrier** provides intrinsically safe isolation for communication with Dwyer® transmitters approved for use in hazardous areas. This galvanic barrier eliminates the need for a high integrity earth ground required when using shunt type diode type safety barriers. DIN rail mounting and plug-in signal and power connectors simplify installation and maintenance.

**FEATURES/BENEFITS**

- Designed to mount on most standard DIN rails
- Approved for use in hazardous areas

**APPLICATIONS**

- Electrically isolates pressure and level transmitters from unregulated circuits for intrinsically safe applications

MODEL CHART		ACCESSORIES	
Model	Description	Model	Description
MTL5541	Galvanic barrier	A-360	Aluminum DIN rail 1 m

COMPATIBLE MODELS: 608, SBLTX, PBLTX, IS626		
Model	Approval	Dwyer Series
MTL 5541	UL for class I; div. 1 groups A, B, C, D class II div. 1 groups E, F, G class III div. 1	IS626, SBLTX, PBLTX
MTL 5541	FM for class I, II, III; div. 1 groups A, B, C, D, E, F, G	608

SPECIFICATIONS	
<p><b>Hazardous Area Input:</b> Signal range: 0-24 mA (including over-range); Transmitter voltage: 16.5 V at 20 mA.</p> <p><b>Safe Area Output:</b> Signal range: 4-20 mA; Under/over-range: 0-24 mA; Load resistance: 0 to 360Ω @ 24 mA, or 0 to 450Ω @ 20 mA; Current sink: 600Ω max.; Maximum Voltage Source: 24 VDC; Output resistance: &gt; 1 MΩ.</p> <p><b>Power Requirement:</b> 20-35 VDC</p> <p><b>Response Time:</b> Settles to within 10% of final value within 50 μs.</p> <p><b>Current Consumption (20 mA signal):</b> 51 mA @ 24V.</p> <p><b>Maximum Power Dissipation (20 mA signal):</b> 0.7 W @ 24 VDC, 1.0 W @ 24 VDC.</p>	<p><b>Isolation:</b> 250 V RMS, tested at 1500 V RMS minimum, between safe- and hazardous-area terminals; 50 V between safe-area circuits and power supply.</p> <p><b>Transfer Accuracy at 68°F (20°C):</b> Better than 15 μA.</p> <p><b>LED Indicator:</b> Green: Power Indication.</p> <p><b>Temperature Limits:</b> Operating: -6 to 140°F (-20 to 60°C); Storage: -40 to 176°F (-40 to 80°C).</p> <p><b>Temperature Drift:</b> &lt; 0.8μA/°C.</p> <p><b>Humidity:</b> 5 to 95% RH.</p> <p><b>Mounting:</b> T-section 35mm DIN rail (7.5 or 15mm) to EN 50022.</p> <p><b>Terminals:</b> Accommodate up to 2.5 mm2 stranded or single-core.</p> <p><b>Safety Description:</b> Vo= 28 V, Io= 93 mA, Po= 651mW, Um= 253 RMS or DC.</p> <p><b>Weight:</b> 150 g.</p> <p><b>Agency Approvals:</b> See table.</p>

Certifying Authority	Standard	Approved For	Certificate/File no.
FM (USA)	FM3600, FM3610, FM3810	Associated Apparatus providing intrinsically safe circuits for Class I, II, III, Division 1, Groups A, B, C, D, E, F, and G when installed per the control drawing SCI-1028; Non-incendive for Class I, Division 2, Groups A, B, C, and D T4; Intrinsic safety for AEx [ia] IIC when installed per the control drawing SCI-1028; Non sparking for Class I, Zone 2, AExnA IIC T4 Gc hazardous (classified) locations with an ambient temperature rating of -200C to +600C	3025815
Canada (CSA)	CSA-C22.2 No. 157-M1992, CSA-C22.2 No. 213-M1987		
UL	UL61010-1 Edition 3 UL913 Edition 8 UL60079-0 Edition 6 UL60079-11 Edition 6	Associated Apparatus for use in Unclassified Locations or Class I, Division 2, Groups A, B, C, D	E120058
CSA	C22.2 No. 142-M1987 C22.2 No. 157-M1992 C22.2 No. 213-M1987 CAN/CSA E60079-0:07 CAN/CSA E60079-11:02 CAN/CSA E60079-15:02	Class I, Division 2, Groups A, B, C, D; Class I, Zone 2, Group IIC; Ex nA [ia] IIC; Ex nC [ia] IIC	LR 36637
ATEX	EN 60079-0:2012 EN 60079-15:2010	Ex nA IIC T4 Gc	Baseefa07ATEX0213 MTL08ATEX5541X BAS01ATEX7217
IECEx (Type 'n')	IEC 60079-0:2011 Edition 6 IEC 60079-15:2010 Edition 4	EX nA IIC T4 Gc	IECEx BAS 15.0119X
IECEx (Intrinsic Safety)	IEC 60079-0:2011 Edition 4 IEC 60079-11:2011 Edition 6	[Ex ia Ga] IIC, [Ex ia Da] IIIC, [Ex ia Ma] I	IECEx BAS 07.0069
IECEx ([Ex ia] I/II/III)	IEC 60079-0:2004 Edition 4 IEC 60079-11:2006 Edition 1 IEC 60079-0:2004 Edition 1 IEC 60079-11:2005 Edition 1	[Ex ia] I/II/III, IECEx ITA 08.0009X	IECEx ITA 08.0009X

**MODEL KFD0**

# GALVANIC BARRIER

## Loop Powered, Intrinsically Safe Isolators

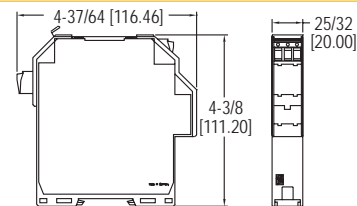

The **Model KFD0 Galvanic Barrier** provides complete isolation for communication with Dwyer® intrinsically safe transmitters approved for use in hazardous areas. This galvanic barrier eliminates the need for a high integrity earth ground required when using shunt type diode type safety barriers. Unlike most other isolators, the Model KFD0-SCSEX1.55 does not require external power and has a low current draw.

**FEATURES/BENEFITS**

- Designed to mount on most standard DIN rails
- Approved for use in hazardous areas

**APPLICATIONS**

- Used to isolate voltages for intrinsically safe applications for HHT series

SPECIFICATIONS	
<p><b>Hazardous Area Input:</b> Signal range: 4-20 mA (linear transmission 1-22 mA); Available transmitter voltage: ≥ 16 V for supply voltage &gt; 21 V.</p> <p><b>Safe Area Output:</b> Signal range: 4-20 mA; Transmitter voltage: ≤ 30 VDC.</p> <p><b>Response Time:</b> ≤ 20 μs at 0, and ≤ 600 μs at 800 load.</p>	<p><b>Maximum Power Dissipation:</b> 150 mW @ 20 mA and V &lt; 24 V.</p> <p><b>Temperature Limits:</b> -4 to 140°F (-20 to 60°C).</p> <p><b>Temperature Drift:</b> ≤ 0.5 μA/°C.</p> <p><b>Weight:</b> 4.2 oz (120 g).</p> <p><b>Agency Approvals:</b> CE, FM.</p>

ACCESSORIES	
Model	Description
A-360	Aluminum DIN rail 1 m

MODEL CHART								
Model	Description	Approval	Dwyer Series	Vo (V)	Io (mA)	Group	μF	mH
KFD0-SCS-EX1.55	Loop powered galvanic barrier	FM for class I, zone 1, groups IIC, IIB, IIA; class I, II, III, div. 2, groups A, B, C, D, F, G	HHT-IX	23.1	38.2	IIC (A, B), IIB (C), IIA (D, F, G)	0.042, 0.267, 0.267	0.5, 2.5, 2.5

# SAFE-T-GROUND

Explosion-Proof, Intrinsically Safe, Ground Continuity Control



TR-7L

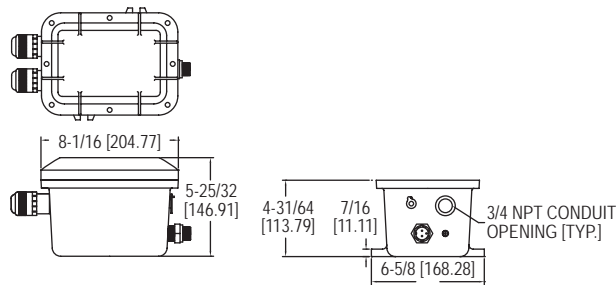

The Series TR-7 Safe-T-Ground provides continuous monitoring of a truck's ground connection throughout loading operations. The TR-7 instantly stops loading operations if a tank truck loses its ground. To safeguard loading operations, the Safe-T-Ground circuit can be wired into your pump control, and to an audible alarm or signal light.

**FEATURES/BENEFITS**

- Explosion-proof housing
- Audible alarm and LED status indicators

**APPLICATIONS**

- Chemical
- Oil and gas

**MODEL CHART**

Example	TR-7	-B	L	TR-7-BL
<b>Construction</b>	TR-7			Explosion-proof and intrinsically safe
<b>Power Supply Option</b>		-U		120 VAC (standard) 220/240 VAC
<b>Cable Connection</b>		-B		Stud (standard) Battery (alligator) clamp
<b>Cable Length</b>			-X	36" coiled, extends to 16' (standard) 72" coiled, extends to 32'
<b>Options</b>			L	Red and green indicating lights

**SPECIFICATIONS**

**Housing:** 356-T6 cast aluminum alloy (copper-free), explosion-proof – Class I, Group D.  
**Size:** 6-5/8" W x 10-3/8" H x 5-5/8" D.  
**Power Requirements:** 105-125 VAC, 60 Hz. 7.75 watts - with light, 1.75 watts - without lights. Optional 220-240 VAC, 50/60 Hz.  
**Electrical Rating, Relay:** DPDT, 10 A, 125 VAC, 60 Hz contact rating.  
**Wiring:** Terminal strip.  
**Conduit Connection:** 3/4" NPT.  
**Installation:** 7/16" mounting lugs, integrally cast.  
**Contactors:** (Grounding clamp) molded polyethylene with beryllium copper contact clips. 16-2 type SO coiled cable; retracts to 3', extends to 16'.  
**Grounding Studs:** 2 supplied. Order a pair for each truck.  
**Shipping Weight:** 20 lb with contactor and cord.  
**Agency Approvals:** UL.  
**Options:** Integral pilot lights; 30' coiled cable; Temporary contactor assemblies, clamp connectors, and other supply voltages.

**MODEL CHART**

Model	Description
TR-7	Safe-T-Ground
TR-7-L	Safe-T-Ground with integral pilot lights

**SERIES SVT**

# SOLENOID VALVE ENCLOSURE WITH TIMER

Compact Size, NEMA 4X Enclosure

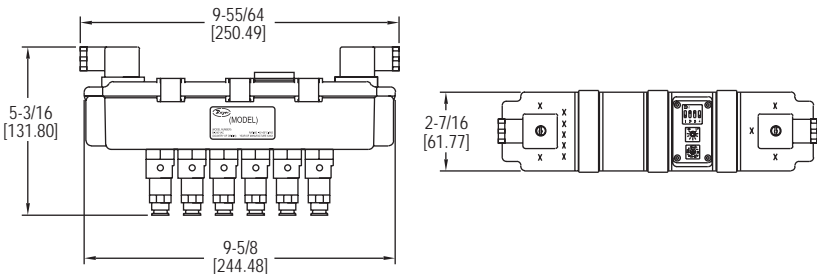

The Series SVT Solenoid Valve Enclosure with Timer is a compact, reliable, and economic package that combines a timer board and solenoid valve enclosure into one package. Each model is available with 2, 4, or 6 valves, but expansion modules can easily be daisy chained for a maximum of 60 outputs.

**FEATURES/BENEFITS**

- Compact, all-in-one package eliminates the need for separate wiring and enclosures
- Universal power requirements for both domestic and overseas use
- Field selectable cleaning functions and on/off settings to personalize for any need

**APPLICATIONS**

- Dust collection
- Pneumatic conveying
- Industrial vacuums

**MODEL CHART**

Model	Description	Number of Solenoids	Supply Voltage	Model	Description	Number of Solenoids	Supply Voltage
SVT-2	Solenoid valve enclosure with timer	2	90-240 VAC	SVT-4-DC	Solenoid valve enclosure with timer	4	24 VDC/VAC
SVT-3	Solenoid valve enclosure with timer	3	90-240 VAC	SVT-6-DC	Solenoid valve enclosure with timer	6	24 VDC/VAC
SVT-4	Solenoid valve enclosure with timer	4	90-240 VAC	SVTE-3	Expansion module	3	Any
SVT-6	Solenoid valve enclosure with timer	6	90-240 VAC	SVTE-4	Expansion module	4	Any
SVT-2-DC	Solenoid valve enclosure with timer	2	24 VDC/VAC	SVTE-6	Expansion module	6	Any
SVT-3-DC	Solenoid valve enclosure with timer	3	24 VDC/VAC				

**Note:** SVTE modules are powered from the main enclosure and can be used with either the 90 to 240 VAC or the 24 VDC/VAC SVT models.

**SPECIFICATIONS**

**Service:** Compatible gases, filtered and oil free.  
**Wetted Materials:** Pilot body: Brass; Spring: 302 SS; O-ring: NBR.  
**Temperature Limits:** 14 to 140°F (-10 to 60°C).  
**Pressure Limit:** 145 psi (10 bar).  
**Power Requirements:** 90-240 VAC, 50 or 60 Hz or 24 VAC/VDC ±10%.  
**Power Consumption:** 25 VA.  
**Fuse:** 0.5 A delayed.  
**Electrical Connection:** 2 DIN A 43652 connectors.  
**Enclosure Rating:** NEMA 4X (IP66).  
**Enclosure Material:** Polyamide with carbon fiber, polycarbonate, TPE rubber.  
**Process Connection:** 1/4" OD push to connect.  
**Mounting Orientation:** Any position.  
**On-Time:** 150 ms to 700 ms.  
**Off-Time:** 4 s to 210 s.  
**Agency Approvals:** CE.

USA: California Proposition 65

⚠ WARNING: Cancer and Reproductive Harm - www.P65Warnings.ca.gov





SERIES DCT500A

# LOW COST TIMER CONTROLLER

Compact, Easy to Use, 4, 6 or 10 Channels

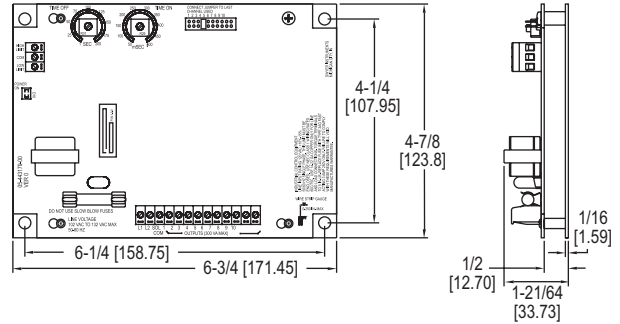
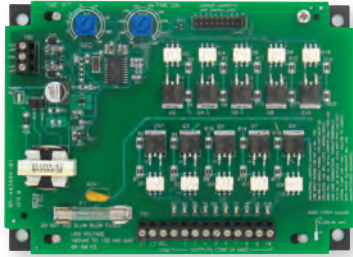

The **Series DCT500A Low Cost Timer Controller** is designed to provide continuous or on-demand cleaning for receivers and pulse jet systems. It is available in either 4, 6, or 10 channels, and each unit is the same size, minimizing enclosure space and reducing overall system installation cost. For added safety, the control circuitry including the control inputs are isolated from the line voltage.

**FEATURES/BENEFITS**

- Simple and easy to use design
- Optional weatherproof enclosure available

**APPLICATIONS**

- Dust collection
- Pneumatic conveying
- Cement batch plants

MODEL CHART		
Model	Description	No. of Channels
DCT504A	Timer controller	4
DCT506A	Timer controller	6
DCT510A	Timer controller	10

SPECIFICATIONS*	
<b>Output Channels:</b> 4, 6, & 10 channels. <b>Power Requirements:</b> 102-132 VAC 50 or 60 Hz. <b>Power Consumption:</b> 2.5 W. <b>Solenoid Supply:</b> 3 A max per channel. <b>Fuse:</b> Type 3 AG, 3 A @ 250 VAC. <b>Temperature Limits:</b> -40 to 140°F (-40 to 60°C).	<b>Storage Temperature Limits:</b> -40 to 176°F (-40 to 80°C). <b>On Time:</b> 50 ms to 500 ms. <b>On Time Accuracy:</b> ±10 ms. <b>On Time Stability:</b> ±1 ms. <b>Off Time:</b> 1 second to 180 seconds. <b>Off Time Accuracy:</b> ±5% of setting. <b>Weight:</b> 9 oz (255 g). <b>Agency Approvals:</b> CE, cULus.

\*Additional specifications on IOM.

OPTIONS	
To order add suffix:	Description
-L	Mounting bracket for field retrofits: 8-1/4" x 6-1/4" (209.55 mm x 158.75 mm)
-WP	Weatherproof housing: standard models Weatherproof housing: with option -L mounting bracket

SERIES DCT500ADC

# LOW COST TIMER CONTROLLER

For Low Voltage Applications

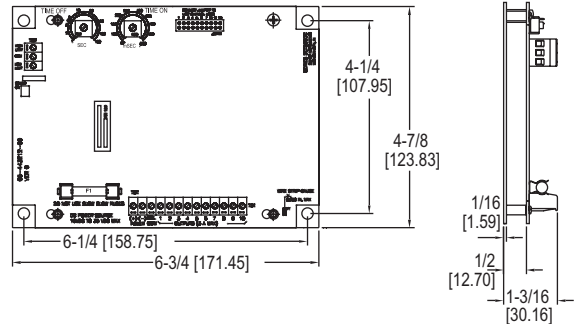
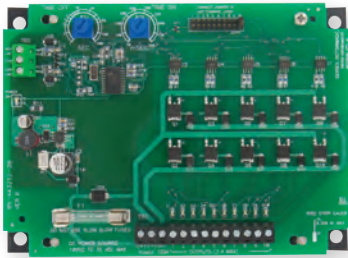

The **Series DCT500ADC Low Cost Timer Controller** is designed to provide continuous or on-demand cleaning for 10-35 volt powered receivers and pulse jet systems. It is available in either 4, 6, or 10 channels, and each unit is the same size, minimizing enclosure space and reducing overall system installation cost. For added safety, the control circuitry including the control inputs are isolated from the line voltage.

**FEATURES/BENEFITS**

- Ideal for low voltage applications
- Simple and easy to use design
- Optional weatherproof enclosure available

**APPLICATIONS**

- Dust collection
- Pneumatic conveying
- Cement batch plants

MODEL CHART		
Model	Description	No. of Channels
DCT504ADC	Timer controller	4
DCT506ADC	Timer controller	6
DCT510ADC	Timer controller	10

SPECIFICATIONS*	
<b>Output Channels:</b> 4, 6, & 10 channels. <b>Power Requirements:</b> 10-35 VDC. <b>Power Consumption:</b> 0.6 W. <b>Solenoid Supply:</b> 3 A max per channel. <b>Fuse:</b> Type 3 AG, 3 A @ 250 VAC. <b>Temperature Limits:</b> -40 to 140°F (-40 to 60°C).	<b>Storage Temperature Limits:</b> -40 to 176°F (-40 to 80°C). <b>On Time:</b> 50 ms to 500 ms. <b>On Time Accuracy:</b> ±10 ms. <b>On Time Stability:</b> < ±1 ms. <b>Off Time:</b> 1 s to 180 s. <b>Off Time Accuracy:</b> ±5% of setting. <b>Weight:</b> 9 oz (255 g). <b>Agency Approvals:</b> CE.

\*Additional specifications on IOM.

OPTIONS	
To order add suffix:	Description
-L	Mounting bracket for field retrofits: 8-1/4" x 6-1/4" (209.55 mm x 158.75 mm)
-WP	Weatherproof housing: standard models Weatherproof housing: with option -L mounting bracket



# TIMER CONTROLLERS

With Universal Power For Both 120 and 220 VAC

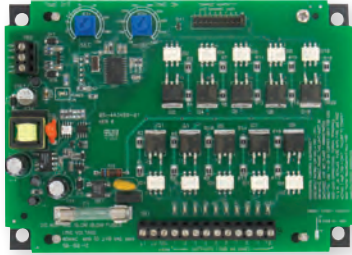

4 thru 10 channel board

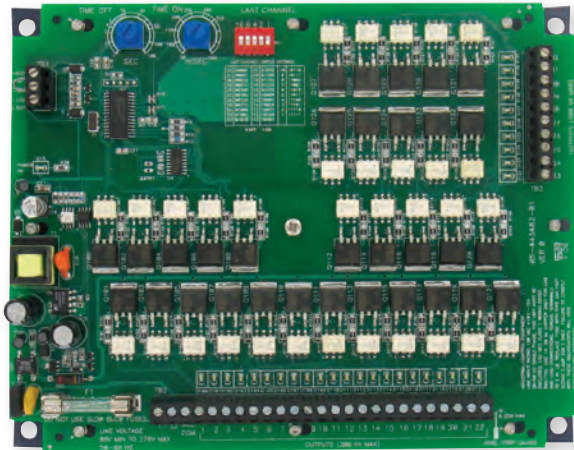

22 and 32 channel board

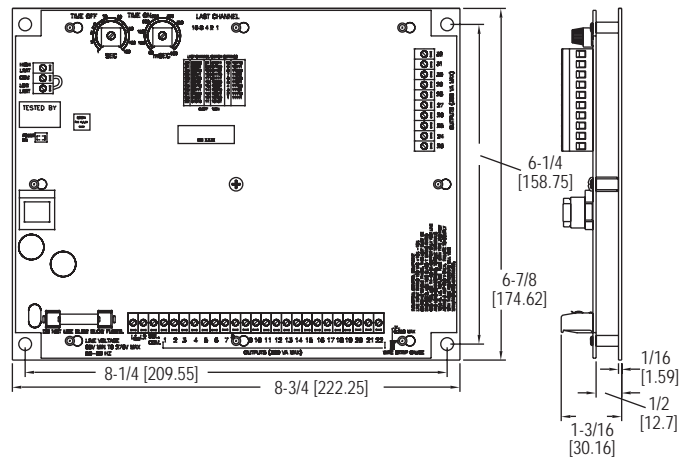
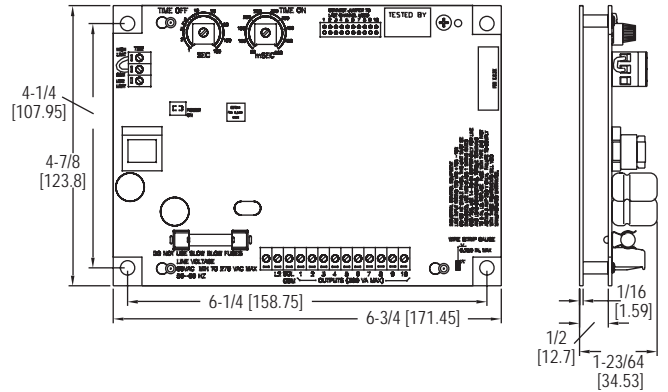

The **Series DCT600 Timer Controllers** are timing systems for pulse-jet type dust collectors or pneumatic conveying systems in either continuous or on-demand cleaning applications. It provides either 4, 6, 10, 22, or 32 channels, and if fewer channels are required than is available on the board, a shorting plug or dip switch allows selection of the last used channel. The new enhanced board circuitry of the DCT600 synchronizes the on-time pulse to the power line to achieve a pulse stability of  $\pm 1$  msec.

**FEATURES/BENEFITS**

- Better synchronized on-time pulse to the power line for better pulse stability
- Adjustable potentiometers to select time-on and time-off settings
- Simple and easy to use design

**APPLICATIONS**

- Dust collection
- Pneumatic conveying

**SPECIFICATIONS\***

**Output Channels:** 4, 6, 10, 22 and 32 channels available.  
**Power Requirements:** 85-270 VAC.  
**Power Consumption:** 1.2 W.  
**Solenoid Supply:** 300 VA.  
**Fuse:** Type 3 AG, 3 A @ 250 VAC.  
**Temperature Limits:** -40 to 140°F (-40 to 60°C).  
**Storage Temperature Limits:** -40 to 176°F (-40 to 80°C).  
**On Time:** 50 ms to 500 ms.  
**On Time Accuracy:**  $\pm 5\%$  of setting.  
**On Time Stability:**  $\pm 1$  ms.  
**Off Time:** 1 s to 180 s.  
**Off Time Accuracy:** 5% of setting.  
**Weight:** 9 oz (255 g).  
**Agency Approvals:** CE, cULus.

\*Additional specifications on IOM.

MODEL CHART		
Model	Description	No. of Channels
DCT604	Timer controller	4
DCT606	Timer controller	6
DCT610	Timer controller	10
DCT622	Timer controller	22
DCT632	Timer controller	32

OPTIONS	
To order add suffix:	Description
-L	Mounting bracket for field retrofits: 8-1/4" x 6-1/4" (209.55 mm x 158.75 mm)
-WP	Weatherproof housing: 4 thru 10 channel only Weatherproof housing: 22 & 32 channels

**Note:** L mounting bracket available with 4, 6, or 10 channel models only.

# DUST COLLECTOR TIMER CONTROLLER

Modular Design, User Friendly, Up to 22 Channels

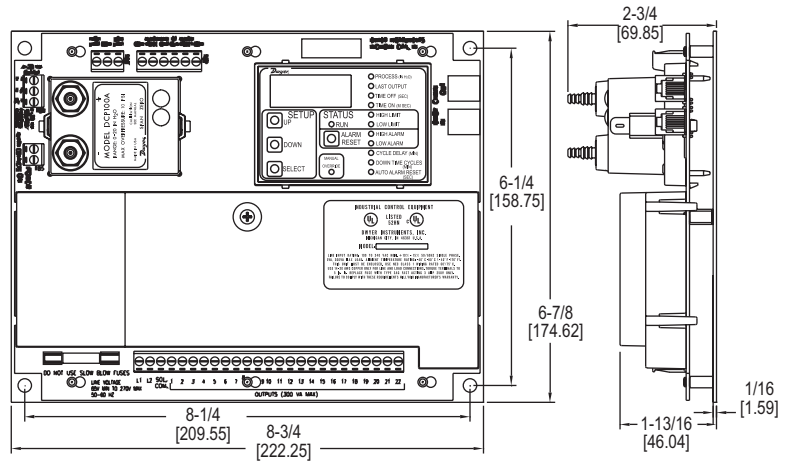
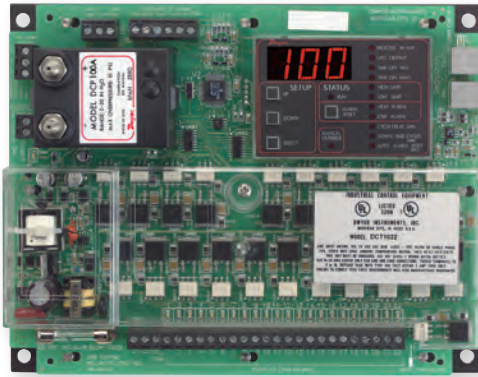

The **Series DCT1000 Dust Controller Timer Controller** simplifies on-demand cleaning requirements by eliminating the need for external devices such as pressure switches, relays, and timers. The modular design allows for use as a continuous cleaning control or on-demand cleaning control using the optional plug-in pressure module. The DCT1000 is the same size for 6, 10, and 22 channels, allowing one board size to be the standard on one enclosure.

**FEATURES/BENEFITS**

- Universal power requirements for both domestic and overseas use
- Standard mounting holes to other dust collector controllers for use in existing installations
- Able to automatically detect any channel expander connected

**APPLICATIONS**

- Dust collection
- Pneumatic conveying

MODEL CHART			
Model	Description	No. of Channels	D.P. Range
DCT1022	Master controller	22	-
DCT1010	Master controller	10	-
DCT1006	Master controller	6	-
DCT1122	Channel expander	22	-
DCT1110	Channel expander	10	-
DCP200A	Pressure module	-	20 in w.c.
DCP100A	Pressure module	-	10 in w.c.

OPTIONS	
To order add suffix:	Description
-WP	Weatherproof housing only
-WPP	Weatherproof housing with pressure ports
-WPPS	Weatherproof housing with pressure ports, three position rotary switch installed
-EXPL	Explosion-proof housing

**Note:** Multiple boards stacked in enclosure.

ACCESSORIES	
Model	Description
DPMA-402	Process indicator

**Note:** DCA channel expander cable available in 1 ft, 2 ft, and 4 ft lengths.

SPECIFICATIONS	
<p><b>DCT1000 TIMER CONTROLLER</b></p> <p><b>Output Channels:</b> 6, 10, &amp; 22 channels. Expandable to 255 channels using DCT1122 &amp; DCT1110 channel expander boards.</p> <p><b>Power Requirements:</b> 85-270 VAC, 50 or 60 Hz.</p> <p><b>Power Consumption:</b> 5 W.</p> <p><b>Solenoid Supply:</b> 3 A max per channel.</p> <p><b>Fuse:</b> 3 A @ 250 VAC. Low voltage control circuitry is isolated from the line voltage for system safety.</p> <p><b>Temperature Limits:</b> -40 to 140°F (-40 to 60°C).</p> <p><b>Storage Temperature Limits:</b> -40 to 176°F (-40 to 80°C).</p> <p><b>On Time:</b> 10 ms to 600 ms, 10 ms steps.</p> <p><b>On Time Accuracy:</b> ±10 ms.</p> <p><b>Off Time:</b> 1 s to 255 s, 1 s steps.</p> <p><b>Off Time Accuracy:</b> ±1% of the value or ±50 ms, whichever is greater.</p> <p><b>Weight:</b> 1 lb 3.0 oz (538.6 g).</p> <p><b>Agency Approvals:</b> cULus.</p>	<p><b>DCP PRESSURE MODULE</b></p> <p><b>Pressure Ranges:</b> 10 in w.c. or 20 in w.c.</p> <p><b>Temperature Limits:</b> -40 to 140°F (-40 to 60°C).</p> <p><b>Pressure Limit:</b> 10 psi (68.95 kPa). Pressure Limit (differential): 10 psi (68.95 kPa).</p> <p><b>Accuracy:</b> ±1.5% FS @ 73°F (22.8°C).</p> <p><b>Output Signal:</b> 4-20 mA.</p> <p><b>Alarm Contacts:</b> 1.5 A inductive load, 3 A resistive load @ 30 VAC or 40 VDC.</p> <p><b>Process Connections:</b> Two barbed connections for use with 1/8" (3.18 mm) or 3/16" (4.76 mm) ID tubing.</p> <p><b>Weight:</b> 5.5 oz (155.9 g).</p>



DCT in optional NEMA 4/4X weatherproof enclosure



DCT in optional Explosion-proof enclosure



DCAC02 cable connection for connecting multiple boards



Master board stacked with channel expander



# DUST COLLECTOR TIMER CONTROLLER

For Low Voltage Applications

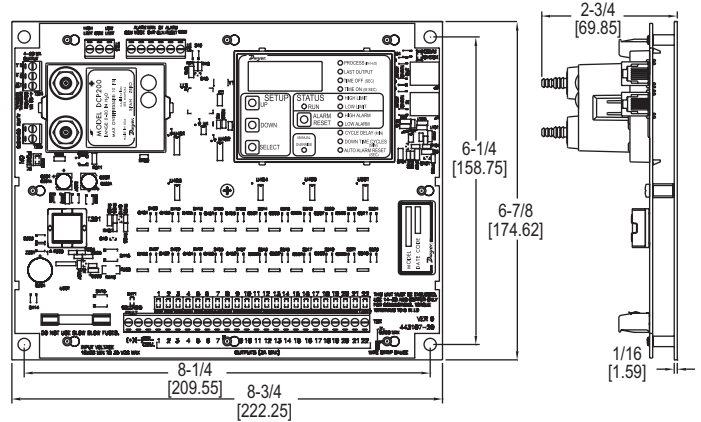
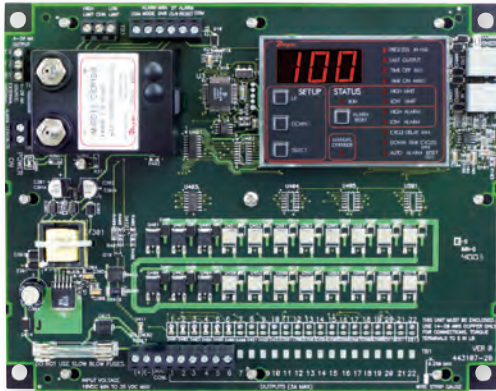

The **Series DCT1000DC Dust Collector Timer Controller** simplifies on-demand cleaning requirements in low voltage applications by eliminating the need for external devices such as pressure switches, relays, and timers. The modular design allows for use as a continuous cleaning control or on-demand cleaning control using the optional plug-in pressure module. The DCT1000 is the same size for 6, 10, and 22 channels, allowing one board size to be the standard on one enclosure.

**FEATURES/BENEFITS**

- 10 to 30 VDC power requirement for low voltage applications
- Standard mounting holes to other dust collector controllers for use in existing installations
- Able to automatically detect any channel expander connected

**APPLICATIONS**

- Dust collection
- Pneumatic conveying

MODEL CHART			
Model	Description	No. of Channels	D.P. Range
DCT1022DC	Master controller	22	-
DCT1010DC	Master controller	10	-
DCT1006DC	Master controller	6	-
DCP200A	Pressure module	-	20 in w.c.
DCP100A	Pressure module	-	10 in w.c.

OPTIONS	
To order add suffix:	Description
-WP	Weatherproof housing only
-WPP	Weatherproof housing with pressure ports
-WPPS	Weatherproof housing with pressure ports, three position rotary switch installed
-EXPL	Explosion-proof housing

ACCESSORIES	
Model	Description
DPMA-402	Process indicator

**SPECIFICATIONS**

**DCT1000DC TIMER CONTROLLER**  
**Output Channels:** 6, 10, & 22 channels.  
**Power Requirements:** 10-30 VDC.  
**Solenoid Supply:** 3 A maximum per channel.  
**Fuse:** 3 A @ 250 VAC.  
**Temperature Limits:** -40 to 140°F (-40 to 60°C).  
**Storage Temperature Limits:** -40 to 176°F (-40 to 80°C).  
**On Time:** 10 ms to 600 ms, 10 ms steps.  
**On Time Accuracy:** ±10 ms.  
**Off Time:** 1 s to 255 s, 1 s steps.  
**Off Time Accuracy:** ±1% of the value or ±50 ms, whichever is greater.  
**Weight:** 1 lb 3.0 oz (538.6 g).

**DCP PRESSURE MODULE**  
**Pressure Ranges:** 10 in w.c. or 20 in w.c.  
**Temperature Limits:** -40 to 140°F (-40 to 60°C).  
**Pressure Limit:** 10 psi (68.95 kPa).  
**Pressure Limit (differential):** 10 psi (68.95 kPa).  
**Accuracy:** ±1.5% FS @ 73°F (22.8°C).  
**Output Signal:** 4-20 mA.  
**Alarm Contacts:** 1.5 A inductive load, 3 A resistive load @ 30 VAC or 40 VDC.  
**Process Connections:** Two barbed connections for use with 1/8" (3.18 mm) or 3/16" (4.76 mm) ID tubing.  
**Weight:** 5.5 oz (155.9 g).  
**Agency Approvals:** CE.



DCT in optional NEMA 4/4X weatherproof enclosure



DCT in optional Explosion-proof enclosure



# PARTICULATE TRANSMITTER

## Digital Damping, Non-Stick Probe, For Broken Bag Detection



THREADED MOUNT	
Probe Length	A in [mm]
3"	3 [76.20]
5"	5 [127.00]
10"	10 [254.00]
15"	15 [381.00]
20"	20 [508.00]
30"	30 [762.00]
36"	36 [914.40]

1.5" TRI-CLAMP MOUNT		
Probe Length	A in [mm]	B in [mm]
3"	3-1/2 [88.90]	1-25/32 [45.24]
5"	5-1/2 [139.70]	3-25/32 [96.04]
10"	10-1/2 [266.70]	8-25/32 [223.04]
15"	15-1/2 [393.70]	13-25/32 [350.04]
20"	20-1/2 [520.70]	18-25/32 [477.04]
30"	30-1/2 [744.70]	28-25/32 [731.04]
36"	36-1/2 [927.10]	34-25/32 [883.44]

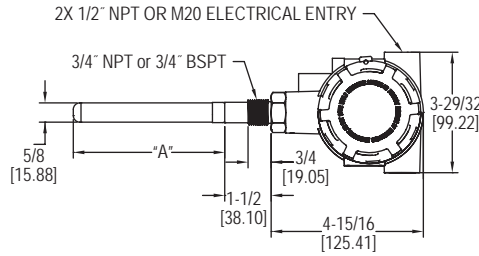

**3/4" male NPT or 3/4" male BSPT mount**

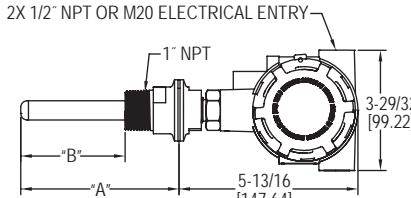

**1.5" Tri-clamp option mount**

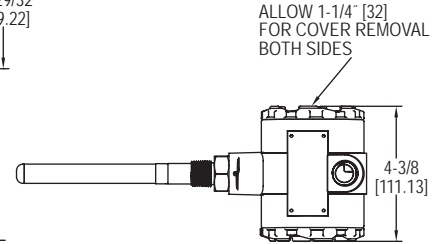

The **Series PMT2 Particulate Transmitter** is designed to measure particulate emission levels from dust collector discharge. Using DC coupled electrostatic induction sensing technology, the transmitter monitors a pA current that is generated as particulate passes near the probe; a 4-20 mA signal will vary based on the particulate level. The PMT2 offers 6 sensitivity ranges allowing the user to choose the range that will best fit the application. The range and test selector switch can also be set to output a 4 mA or 20 mA signal to assist with set up or trouble shooting. Averaging time setting can be used to dampen the signal if desired.

**FEATURES/BENEFITS**

- Simple 2-wire installation for PLC and control panels
- Non-stick PTFE coated probe to prevent false readings from moist and conductive dusts, condensate, and dust buildup
- Remote zero calibration helps to decrease maintenance time

**APPLICATIONS**

- Emissions monitoring
- Broken bag detection in dust collectors
- Filter leak or wear detection
- Bin vent monitoring

**MODEL CHART**

Example	PMT2	-05	-A	-U2	PMT2-05-A-U2
Series	PMT2				Particulate transmitter
Probe Length		03 05 10 15 20 30 36			3" probe length 5" probe length 10" probe length 15" probe length 20" probe length 30" probe length 36" probe length
Process Connection			A B C		3/4" male NPT 1.5" tri-clamp kit with 1" male NPT 3/4" male BSPT
Enclosure Rating				A2 U2	ATEX and IECEx (IS) UL (IS)*
Options				ST M2	Stainless steel tag Female M20 electrical entries (female 1/2" NPT standard)

\*Options that do not have ATEX or IECEx.  
Attention: Units without the A2 suffix are not Directive 2014/34/EC (ATEX) compliant. These Units are not intended for use in potentially hazardous atmospheres in the EU. These units may be CE marked for other Directives of the EU.

**SPECIFICATIONS**

**Service:** Air and compatible gases, any type of particulate conductive or non-conductive.  
**Wetted Materials:** 316L SS, silicone, and PTFE.  
**Enclosure:** Powder coated aluminum.  
**Accuracy:** ±5% of reading.  
**Particulate Size:** 0.3 microns and higher.  
**Detection Range:** 5 to 5000 pA (6 selectable range options).  
**Temperature Limits:** Ambient: -40 to 145°F (-40 to 63°C); Process: -40 to 248°F (-40 to 120°C).  
**Pressure Limit:** 30 psi (2 bar).  
**Output Signal:** 4-20 mA.  
**Power Requirements:** 12-28 VDC (≡).  
**Electrical Connection:** Two 1/2" female NPT electrical entries or two M20 electrical entries (A2 suffix only).  
**Terminal Block:** Removable (16 to 20 AWG wire).  
**Process Connection:** See model chart. BSPT process connections are not UL listed.  
**Probe Lengths:** See model chart.  
**Enclosure Rating:** UL Type 4 (IP66) ATEX/IECEx IP65.  
**Mounting Orientation:** Any.  
**Averaging Time:** 1 to 360 s (10 selectable options).  
**Weight:** Varies with length of probe and type of mount.  
**Agency Approvals:** CE, cULus; ATEX Compliant: **CE** 0518 **Ex** II 1 G Ex ia IIB T4 Ga (-40°C ≤ Tamb ≤ 63°C) (-40°C ≤ T<sub>Process</sub> ≤ 120°C) / II 1 D Ex ia IIIC T120°C Da (-40°C ≤ Tamb ≤ 63°C) (-40°C ≤ T<sub>Process</sub> ≤ 120°C). Type Certificate No.: DEMKO 16ATEX1768 X. ATEX Standards: EN 60079-0:2012/A11:2013; EN 60079-11:2012. IECEx Certified: Ex ia IIB T4 Ga (-40°C ≤ Tamb ≤ 63°C) (-40°C ≤ T<sub>Process</sub> ≤ 120°C) / Ex ia IIIC T120°C Da (-40°C ≤ Tamb ≤ 63°C) (-40°C ≤ T<sub>Process</sub> ≤ 120°C). Certificate of Conformity: IECEx UL 16.013X. IECEx Standards: IEC 60079-0: 2011; IEC 60079-11: 2011. UL Listed Intrinsically Safe for Class I, Groups C and D; Class II, Groups E, F and G; Class III; Class I Zone 0 AEx ia IIB T4 Ga; Class I Zone 0 Ex ia IIB T4 Ga.

**ACCESSORIES**

Model	Description
<b>A-PMT2-M20</b>	1/2" NPT to M20 conduit adaptor
<b>A-PMT2-FLG</b>	2" flange with 3/4" NPT female connection, 316 SS

Particulate (Dust or Broken Bag) Transmitters



# PARTICULATE MONITOR & CONTROL

## Real-Time Leak Gage, Adjustable Alarm Points

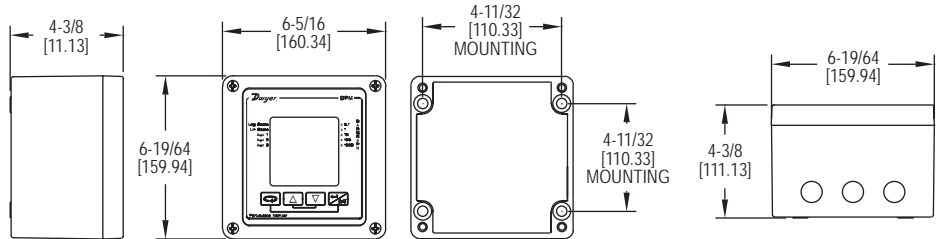

The **Series DPM Particulate Monitor & Control** and Series PMS Particulate Sensor combine to provide a basic baghouse and cartridge filter leak detector designed for general maintenance planning and process protection. Leakage is gauged in real-time, on-the-spot, without prior baseline data and without signal tuning and displayed on the digital readout in a bar graph and an absolute digital readout. An alarm point can be set by simply moving an indicator up and down the gauge with the key pad.

### FEATURES/BENEFITS

- Rugged cast aluminum housing with lockable membrane keypad
- Programmable alarm points
- Large LCD to display readouts digitally

### APPLICATIONS

- Baghouses
- Bin vents
- Cartridge filters

MODEL CHART			
Model	System Rating	Range	Input Power
DPM-A111	Weatherproof/NEMA 4X (IP66)	5.0-5000 pA	115 VAC 50/60 Hz
DPM-A112	Weatherproof/NEMA 4X (IP66)	5.0-5000 pA	230 VAC 50/60 Hz
DPM-A113	Weatherproof/NEMA 4X (IP66)	5.0-5000 pA	24 VDC
DPM-A121	Weatherproof/NEMA 4X (IP66)	0.5-5000 pA	115 VAC 50/60 Hz
DPM-A122	Weatherproof/NEMA 4X (IP66)	0.5-5000 pA	230 VAC 50/60 Hz
DPM-A123	Weatherproof/NEMA 4X (IP66)	0.5-5000 pA	24 VDC
DPM-AHZ111	Intrinsically safe*	5.0-5000 pA	115 VAC 50/60 Hz
DPM-AHZ112	Intrinsically safe*	5.0-5000 pA	230 VAC 50/60 Hz
DPM-AHZ113	Intrinsically safe*	5.0-5000 pA	24 VDC
DPM-AHZ121	Intrinsically safe*	0.5-5000 pA	115 VAC 50/60 Hz
DPM-AHZ122	Intrinsically safe*	0.5-5000 pA	230 VAC 50/60 Hz
DPM-AHZ123	Intrinsically safe*	0.5-5000 pA	24 VDC

\*DPM models listed intrinsically safe are to be used with corresponding intrinsically safe PMS models making an intrinsically safe control loop. The PMS model can then be installed in a hazardous location according to approval ratings listed. The DPM itself is not intrinsically safe and must be installed outside the hazardous location.

OPTIONS	
To order add suffix:	Description
-RC	Analog output (4-20 mA)

### SPECIFICATIONS

**Inputs:** From PMS sensor.  
**Output Ratings:** Alarm relays: 2 form A (SPST) rated 5 A @ 240 V res. (must provide an 8 A (max) fuse in series with relay load); Analog: 4-20 mA (option RC).  
**Power Requirements:** 115 VAC 50/60 Hz, 230 VAC 50/60 Hz, or 24 VDC.  
**Power Consumption:** 6 W max.  
**Accuracy:** Standard: ±5% of range, Optional: ±1% of range.  
**Display:** LCD.  
**Display Resolution:** Standard: 5 pA; Optional: 0.5 pA.  
**Memory Backup:** For set point storage only.  
**Temperature Limits:** -13 to 160°F (-25 to 70°C).  
**Weight:** 4.5 lb (2.0 kg).  
**Enclosure:** Cast aluminum, weatherproof, NEMA 4X (IP66).  
**Loop Power Supply (Isolated):** 17 VDC loop supply provided by DPM control unit for PMS sensor.  
**Agency Approvals:** CE & CSA.\*

\*DPM models listed intrinsically safe are to be used with corresponding intrinsically safe PMS models making an intrinsically safe control loop. The PMS model can then be installed in a hazardous location according to approval ratings listed. The DPM itself is not intrinsically safe and must be installed outside the hazardous location.

# PARTICULATE SENSOR

## Reliable Operation, Minimal Maintenance

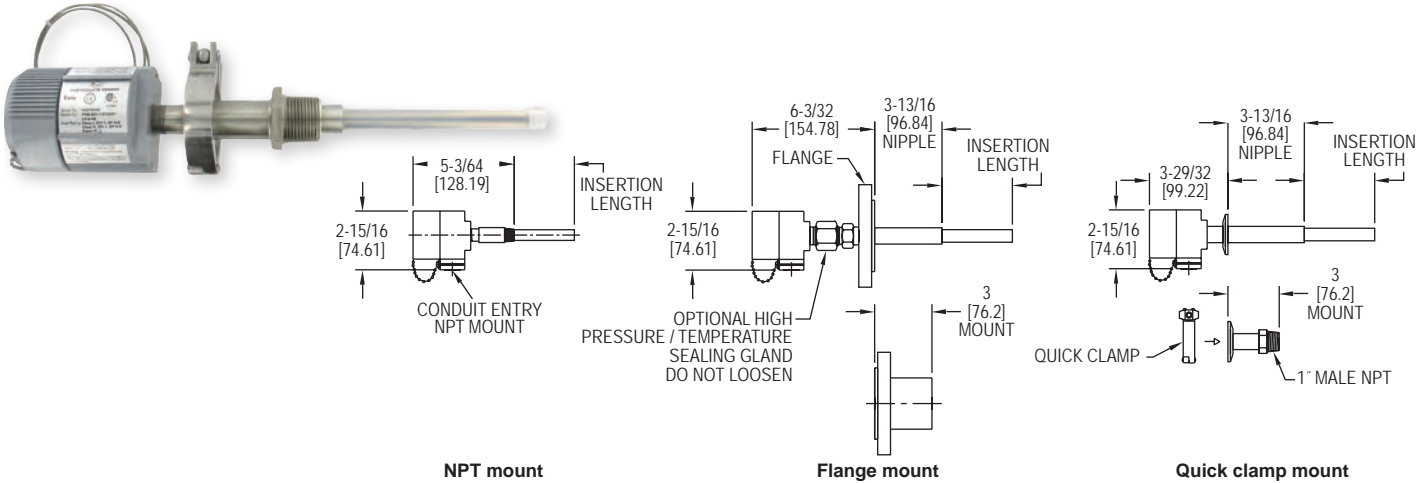

The **Series PMS Particulate Sensor** employs a field-proven combination of passive-induction and protected-probe technologies. As particles flow near and around the probe, the signal is processed into an absolute output that can be sent to a Series DPM Particulate Monitor. Protective layers over the probe work in combination with induction-sensing to ensure reliable operation with all types of particulate including moist powders and highly conductive dusts.

**FEATURES/BENEFITS**

- Durable housing that is free of electronics
- Minimal maintenance needed

**APPLICATIONS**

- Baghouses
- Bin vents
- Cartridge filters

SPECIFICATIONS	
<b>Service:</b>	Air and compatible gases, any type particulate.
<b>Wetted Materials:</b>	T1 and T2: 316 SS and PFA; T3 and T4: 316 SS and ceramic.
<b>Temperature Limits:</b>	Ambient: Maximum -40 to 392°F (-40 to 200°C) (max must be calculated for each application); Process: See model chart.
<b>Pressure Limits:</b>	Standard: Full vacuum to 10 psi (0.69 bar); Optional: 100 psi (6.89 bar).
<b>Output Signal:</b>	pA.
<b>Electrical Connection:</b>	Low noise coaxial.
<b>Process Connection:</b>	See model chart.
<b>Enclosure:</b>	Standard: Painted cast aluminum, weatherproof, NEMA 4X (IP66); Optional: Intrinsically safe, CSA (must use with proper DPM model).
<b>Weight:</b>	Varies depending on length of probe and type of mount.
<b>Agency Approvals:</b>	CE, CSA.

Particulate (Dust or Broken Bag) Sensors

MODEL CHART							
<b>Example</b>	PMS	-A1	1	T1	P1	-L1.5	PMS-A11T1P1-L1.5
<b>Series</b>	PMS						Particulate sensor
<b>Enclosure Rating</b>		A1 AHZ1					Weatherproof, NEMA 4X (IP66) Intrinsically safe, CSA & CEA approvals, class I, II, and III; division I & II, all groups, NEMA 4X (requires quick clamp connection or flange mount)
<b>Process Connection</b>			1 2 3 4				1/2" NPT 1" NPT with 1.5" quick clamp connection 2" 150# ANSI flange 2" 150# ANSI flange with process mating flange and installation kit
<b>Maximum Process Temperature</b>				T1 T2 T3 T4			250°F (121°C) 450°F (232°C) 800°F (426°C) - requires flange mount 1200°F (649°C) - requires flange mount
<b>Maximum Process Pressure</b>					P1 P2		10 psi 100 psi - requires flange mount
<b>Insertion Length*</b>						L1.5 L03 L05 L10 L15 L20 L30 L36 L48 L60 L72	1.5" probe 3" probe 5" probe 10" probe 15" probe 20" probe 30" probe 36" probe 48" probe 60" probe 72" probe

\*Recommended at least 1/2 duct diameter

MODEL CHART			
Model	Description	Model	Description
CAB-10	10 foot sensor cable	CAB-30	30 foot sensor cable
CAB-20	20 foot sensor cable	CAB-40	40 foot sensor cable

**Note:** Consult factory for custom cable lengths up to 300 feet.

# GALVANNEALED STEEL ENCLOSURES

Wall Mounted, NEMA 3R, UL Approved

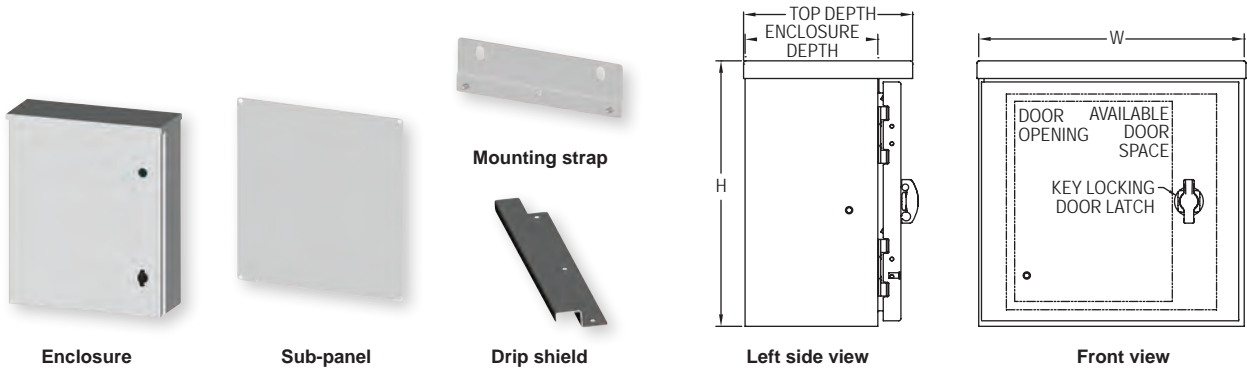

The **Series CSE-3R Galvannealed Steel Enclosures** are spot-welded, wall mounted enclosures designed to house electrical controls, instruments, and components in an outdoor environment. These units are made of carbon steel, NEMA 3R outdoor environment rated and carry a UL approval.

**FEATURES/BENEFITS**

- Concealed hinges that allow 180° of rotation for easy instrumentation access
- Quarter turn latch that can be opened/closed with a screwdriver, and ground studs on the door and body
- Mounting holes on the back of the enclosure allow for versatile mounting and standoffs provide easy installation of optional sub-panels. A rain cap and an oil resistant door gasket will protect instruments from rain, sleet, and snow. Each unit includes a 3/8-16 grounding kit and has the option of including a sub-panel, mounting strap, and/or a drip shield. This series is the perfect accessory for a variety of instrumentation in need of outdoor protection

**APPLICATIONS**

- HVAC indoor applications
- Housing general controls and gages

**SPECIFICATIONS**

**Materials:** Galvannealed steel enclosure; All other components: Carbon steel.  
**Rating:** NEMA 3R (IP32).  
**Dimensions:** See chart for enclosure dimensions; Sub-panel height = enclosure height - 3" (76 mm); Sub-panel width = enclosure width - 3" (76 mm); Mounting strap width = enclosure width - 4" (102 mm); Drip shield width = enclosure width.  
**Thickness:** 0.048" (1.22 mm) for drip shields; 0.060" (1.52 mm) for enclosures < 24" wide; 0.075" (1.91 mm) for enclosures ≥ 24" wide; 0.125" (3.18 mm) for sub-panels; 0.078" (1.98 mm) for mounting straps.  
**Weight:** See chart.  
**Agency Approvals:** CSA, cULus. (Meets the technical requirements of EU Directive 2011/65/EU (RoHS II)).

MODEL CHART										
Enclosure* Model	Height in (cm)	Width in (cm)	Depth in (cm)	Weight lb (kg)	Sub Panel* Model	Weight lb (kg)	Mounting Strap* Model	Weight lb (kg)	Drip Shield* Model	Weight lb (kg)
CSE-3R-121206	12 (30)	12 (30)	6 (15)	15 (7)	A-SSE-P-1212	3 (1.4)	A-CSE-3M-12	2 (0.9)	A-CSE-D-12	2 (0.9)
CSE-3R-161206	16 (41)	12 (30)	6 (15)	16 (7)	A-SSE-P-1612	4 (1.8)	A-CSE-3M-16	2 (0.9)	A-CSE-D-16	2 (0.9)
CSE-3R-201606	20 (51)	16 (41)	6 (15)	25 (11)	A-SSE-P-2016	8 (3.6)	A-CSE-3M-20	3 (1.4)	A-CSE-D-20	3 (1.4)
CSE-3R-242006	24 (61)	20 (51)	6 (15)	32 (15)	A-SSE-P-2420	14 (6.4)	A-CSE-3M-24	4 (1.8)	A-CSE-D-24	4 (1.8)
CSE-3R-302408	30 (76)	24 (61)	8 (20)	60 (27)	A-SSE-P-3024	22 (10)			A-CSE-D-30	4 (1.8)
CSE-3R-362408	36 (91)	24 (61)	8 (20)	62 (28)	A-SSE-P-3624	27 (12.2)				
CSE-3R-363008	36 (91)	30 (76)	8 (20)	70 (32)	A-SSE-P-3630	34 (15.4)				

\*For additional sizes contact factory.

ACCESSORIES	
Model	Description
A-CSE-L	Keylocking wing knob door latch, Includes 1 lock and 2 keys
A-CSE-K	Replacement keys, includes 2 keys





SERIES CSE-N1 & CSE-KN



# CARBON STEEL ENCLOSURES

Wall Mounted, General Purpose Enclosure, UL Approved

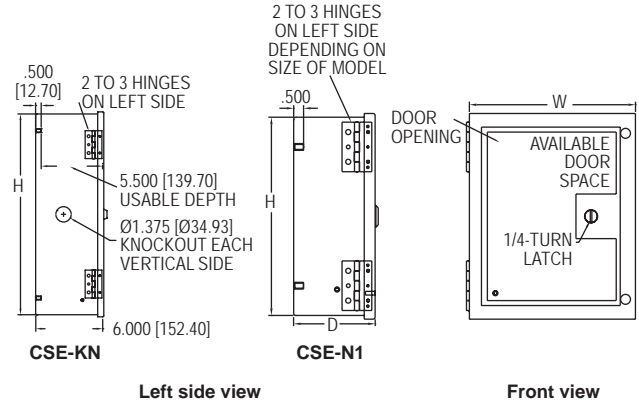
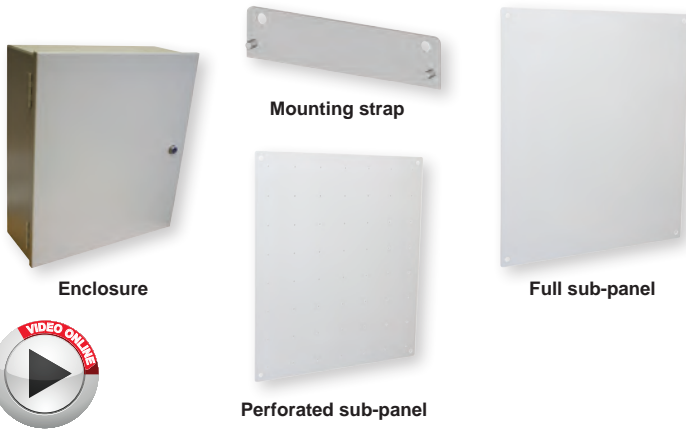

The Series CSE-N1 & CSE-KN Carbon Steel Enclosures are spot-welded, wall mounted, general purpose enclosures designed to house electrical controls, instruments, and components in general purpose areas. The Series CSE-KN also includes knockouts to allow cords to pass easily into the unit.

**FEATURES/BENEFITS**

- The door features hinges that allow 180° of rotation for easy instrumentation access
- Quarter turn latch can easily be opened or closed with a screwdriver
- Included ground stud for easy electrical grounding
- Mounting holes included on the back of the enclosure allow for versatile mounting and standoffs provide easy installation of optional sub-panels
- Each unit offers optional solid or perforated sub-panel and mounting straps for easy instrument mounting
- The CSE-KN series includes a sub-panel with a 2" x 2" (50.8 mm x 50.8 mm) mounting grid mounted on standoffs and lock with keys

**APPLICATIONS**

- HVAC indoor applications
- Housing general controls and gages
- Securing instrumentation and avoiding tampering

**SPECIFICATIONS**

**Materials:** Carbon steel.  
**Rating:** NEMA 1.  
**Dimensions:** See chart.  
**Thickness:** 0.060" (1.52 mm) for enclosures <24" wide; 0.075" (1.91 mm) for enclosures ≥ 24" wide; 0.060" (1.52 mm) for perforated sub-panels; 0.075" (1.91 mm) for solid sub-panels; 0.078" (1.98 mm) for mounting straps.  
**Weight:** See chart.  
**Agency Approvals:** CSA, cULus. (Meets the technical requirements of EU Directive 2011/65/EU (RoHS II)).

MODEL CHART												
Enclosure* Model	Height in (cm)	Width in (cm)	Depth in (cm)	Weight lb (kg)	Sub-Panel* Model**	Height in (cm)	Width in (cm)	Weight lb (kg)	Sub-Panel* Model**	Height in (cm)	Width in (cm)	Weight lb (kg)
CSE-N1-100804	10 (25)	8 (20)	4 (10)	7 (3.2)	A-CSE-1S-1008	8 (20)	6 (15)	2 (0.9)	A-CSE-1S-2016	18 (46)	14 (36)	6 (2.7)
CSE-N1-101004	10 (25)	10 (25)	4 (10)	8.5 (3.9)	A-CSE-1P-1008	8 (20)	6 (15)	1 (0.5)	A-CSE-1P-2016	18 (46)	14 (36)	3 (1.4)
CSE-N1-121004	12 (30)	10 (25)	4 (10)	5 (2.3)	A-CSE-1S-1010	8 (20)	8 (20)	1 (0.5)	A-CSE-1S-2020	18 (46)	18 (46)	7 (3.2)
CSE-N1-121204	12 (30)	12 (30)	4 (10)	10 (4.5)	A-CSE-1P-1010	8 (20)	8 (20)	1 (0.5)	A-CSE-1P-2020	18 (46)	18 (46)	4 (1.8)
CSE-N1-141204	14 (36)	12 (30)	4 (10)	10 (4.5)	A-CSE-1S-1210	10 (25)	8 (20)	3 (1.4)	A-CSE-1S-2416	22 (56)	14 (36)	7 (3.2)
CSE-N1-161206	16 (41)	12 (30)	6 (15)	11 (5)	A-CSE-1P-1210	10 (25)	8 (20)	1 (0.5)	A-CSE-1P-2416	22 (56)	14 (36)	5 (2.3)
CSE-N1-161606	16 (41)	16 (41)	6 (15)	16 (7.3)	A-CSE-1S-1212	10 (25)	10 (25)	4 (1.8)	A-CSE-1S-2420	22 (56)	18 (46)	9 (4.1)
CSE-N1-201606	20 (51)	16 (41)	6 (15)	21 (9.5)	A-CSE-1P-1212	10 (25)	10 (25)	2 (0.9)	A-CSE-1P-2420	22 (56)	18 (46)	7 (3.2)
CSE-N1-202006	20 (51)	20 (51)	6 (15)	25 (11.3)	A-CSE-1S-1412	12 (30)	10 (25)	3 (1.4)	A-CSE-1S-2424	22 (56)	22 (56)	11 (5)
CSE-N1-241606	24 (61)	16 (41)	6 (15)	27 (12.2)	A-CSE-1P-1412	12 (30)	10 (25)	2 (0.9)	A-CSE-1P-2424	22 (56)	22 (56)	8 (3.6)
CSE-N1-242006	24 (61)	20 (51)	6 (15)	31.5 (14.3)	A-CSE-1S-1612	14 (36)	10 (25)	3 (1.4)	A-CSE-1S-3024	28 (71)	22 (56)	13 (6)
CSE-N1-242406	24 (61)	24 (61)	6 (15)	41 (18.6)	A-CSE-1P-1612	14 (36)	10 (25)	2 (0.9)	A-CSE-1P-3024	28 (71)	22 (56)	11 (5)
CSE-N1-302406	30 (76)	24 (61)	6 (15)	54 (24.5)	A-CSE-1S-1616	14 (36)	14 (36)	4 (1.8)	A-CSE-1S-3030	28 (71)	28 (71)	17 (8)
CSE-N1-303008	30 (76)	30 (76)	8 (20)	60 (27.2)	A-CSE-1P-1616	14 (36)	14 (36)	2 (0.9)	A-CSE-1P-3030	28 (71)	28 (71)	14 (6)

\*For additional sizes contact factory. \*\*1S denotes a solid steel panel; 1P denotes a perforated steel panel.

MODEL CHART		
Mounting Strap* Model	Width in (cm)	Weight lb (kg)
A-CSE-1M-08	7.1 (18)	1 (0.5)
A-CSE-1M-10	9.1 (23)	1 (0.5)
A-CSE-1M-12	11.1 (28)	1 (0.5)
A-CSE-1M-16	15.1 (38)	2 (0.9)
A-CSE-1M-20	19.1 (49)	2 (0.9)
A-CSE-1M-24	23.1 (59)	3 (1.4)

\*For additional sizes contact factory.

MODEL CHART								
Enclosure Model	Height in (cm)	Width in (cm)	Depth in (cm)	Weight lb (kg)	Mounting Strap Model	Width in (cm)	Weight lb (kg)	
CSE-KN-181606	18 (46)	16 (41)	6 (15)	22 (10)	A-CSE-1M-16	15.1 (38)	2 (0.9)	
CSE-KN-242006	24 (61)	20 (51)	6 (15)	35 (16)	A-CSE-1M-20	19.1 (49)	2 (0.9)	
CSE-KN-362406	36 (91)	24 (61)	6 (15)	58 (26)	A-CSE-1M-24	23.1 (59)	3 (1.4)	

ACCESSORIES	
Model	Description
A-CSE-L	Keylocking wing knob door latch, includes 1 lock and 2 keys
A-CSE-K	Replacement keys, includes 2 keys



A-CSE-L



**SELECTION GUIDE**  
pages 378-381

**TYPICAL APPLICATIONS**  
page 382

**TECHNICAL INFORMATION**  
page 383

  
**Valves, Ball, Automated**  
pages 384-400, 404-412

  
**Valves, Ball, Manual**  
pages 401-403

  
**Valves, Butterfly, Manual**  
page 413

  
**Valves, Butterfly, Automated**  
pages 414-415

  
**Actuators**  
pages 416-417

  
**Valves, Globe**  
pages 418-422, 432

  
**Valves, Angle Seat**  
page 423

  
**Valves, Solenoid**  
pages 424-427

  
**Valves, Diaphragm Pulse**  
pages 428-429

  
**Valves, Check**  
page 430

  
**Valves, Needle**  
page 431

  
**Manifolds**  
pages 433-434

  
**Position Indicators/ Switches/Transmitters**  
pages 435-440

  
**Current to Pressure Transducers**  
pages 441-443

  
**Positioners**  
pages 444-446

  
**Volume Booster**  
page 447

  
**Regulators**  
page 447-448

## FEATURED PRODUCTS

### LUG OR WAFER STYLE BUTTERFLY VALVE

SERIES WE20 | pages 414-415



- Capable of being configured with various actuators and accessories to fit any application
- Limit switches and position indicators can be mounted to manual valves for remote monitoring

### WIRELESSHART® POSITION INDICATOR

SERIES MARK | pages 436-438



- WirelessHART® allows for adjustment of settings without needing to remove the device from a hazardous environment
- Wireless ability saves on installation costs associated with running conduit and wires

## 2-WAY Automated Ball Valves



**SERIES** WE01 - pages 384-385



**SERIES** WE08 - pages 386-387



**SERIES** WE02 - pages 388-389



**SERIES** WE03 - pages 390-391

<b>Body Type</b>	2-way 2-piece	2-way 2-piece	2-way 3-piece	2-way 3-piece
<b>Body Material</b>	316 SS	Brass	316 SS	316 SS
<b>Line Sizes</b>	1/2 to 3"	1/2 to 2"	1/2 to 2"	1/2 to 3"
<b>End Connections</b>	Female NPT	Female NPT	Female NPT	Tri-clamp

## 3-WAY Automated Ball Valves



**SERIES** WE31 - pages 404-405



**SERIES** WE35 - pages 406-407



**SERIES** WE33 - pages 408-409



**SERIES** WE34 - pages 410-411

<b>Body Type</b>	3-way	3-way	3-way	3-way
<b>Body Material</b>	316 SS	Brass	316 SS	316 SS
<b>Line Sizes</b>	1/2 to 2"	1/2 to 2"	1/2 to 2"	1/2 to 3"
<b>End Connections</b>	Female NPT	Female NPT	Tri-clamp	Flange

# 2-WAY Automated Ball Valves



<b>SERIES</b>	<b>WE04</b> - pages 392-393	<b>WE05</b> - pages 394-395	<b>WE06</b> - pages 396-397	<b>WE07</b> - pages 398-399
<b>Body Type</b>	2-way 2-piece	2-way 3-piece	2-way 3-piece V-ball	2-way 2-piece V-ball
<b>Body Material</b>	316 SS	316 SS	316 SS	316 SS
<b>Line Sizes</b>	1/2 to 3"	1/2 to 3"	1/2 to 3"	1/2 to 3"
<b>End Connections</b>	Flange	Socket weld	Female NPT	Flange

# POSITIONERS



<b>SERIES</b>	<b>165 &amp; 265</b> - pages 444-445	<b>185 &amp; 285</b> - page 446	<b>195 &amp; 295</b> - page 446
<b>Body Material</b>	Aluminum or 316 SS	Aluminum or 316 SS	Aluminum
<b>Stroke</b>	0.5 to 6" or 0 to 90°	0.5 to 6" or 0 to 90°	0.19 to 1.38" or 0 to 90°
<b>Air Supply</b>	20 to 101 psig	35 to 116 psi	35 to 116 psi
<b>Enclosure Rating</b>	IP66	NEMA 4X	NEMA 4X

These Selection Guides are for quick comparison of similar products. Please refer to the catalog page number referenced for complete product information and specifications.

**Dwyer**

# HAND LEVER

## Ball Valves



<b>SERIES</b>	<b>DBV</b> - page 401	<b>BV2M</b> - page 401	<b>DBVL</b> - page 402	<b>SWBV</b> - page 402
<b>Body Type</b>	2-way	2-way	2-way	2-way
<b>Body Material</b>	Brass	CF8M	Low lead brass	Brass
<b>Line Sizes</b>	1/4 to 3"	1/4 to 3"	1/4 to 3"	1/4 to 3"
<b>End Connections</b>	Female NPT	Female NPT	Female NPT	Sweat

## POSITION INDICATORS/ SWITCHES/ TRANSMITTERS



<b>SERIES</b>	<b>QV</b> - page 435	<b>Mark 1</b> - pages 436-438	<b>Mark 3</b> - pages 436-438
<b>Type</b>	Thru-shaft	Magnetic drive	Magnetic drive
<b>Rotation Travel</b>	5 to 360° (switches only)	0 to 340°	1 to 25 revolutions
<b>Enclosure Material</b>	Polycarbonate	Aluminum or 316 SS	Aluminum or 316 SS
<b>Enclosure Rating</b>	NEMA 4, 4X	NEMA 1, 2, 3, 3R, 3S, 4, 4X, 6, 7, 9, 12, & 13	NEMA 1, 2, 3, 3R, 3S, 4, 4X, 6, 7, 9, 12, & 13

These Selection Guides are for quick comparison of similar products. Please refer to the catalog page number referenced for complete product information and specifications.



# HAND LEVER Ball Valves



SERIES	UBV - page 402	MV - page 403	SMV2 - page 403
Body Type	Uni-flange	2-way	2-way
Body Material	Brass	Chrome-plated brass	SS
Line Sizes	1/2 to 1"	1/8 to 1/2"	1/8 to 1/2"
End Connections	Female NPT	Female x female NPT or Male x female NPT	Female x female NPT or Male x female NPT

# POSITION INDICATORS/ SWITCHES/ TRANSMITTERS



SERIES	Mark 4 - pages 436-438	VPS - page 439	DT - page 440
Type	Thru-shaft	Dual Inductive	Magnetic Point Sensor
Rotation Travel	0 to 340°	N/A	N/A
Enclosure Material	Aluminum or 316 SS	Polybutylene Terephthalate	SS
Enclosure Rating	NEMA 1, 2, 3, 3R, 3S, 4, 4X, 6, 7, 9, 12, & 13	N/A	Designed to NEMA 1, 3, 4, 4X, 6, 7, 9, 12 & 13

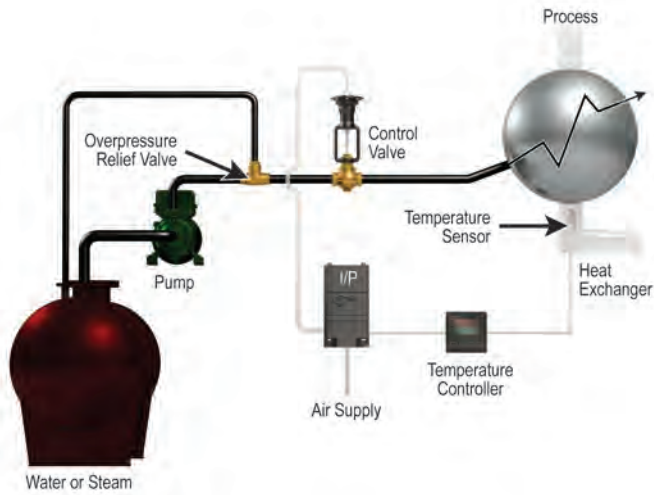

**Process temperature control using pneumatic Hi-Flow™ control valves.**

Pneumatic Hi-Flow™ control valves provide excellent control with high flow, wide rangeability and tight shutoff capabilities. The dispensing application shown uses a Lin-E-Aire® pneumatic actuator, operating off standard 3-15 psi control air signals, and a Hi-Flow™ linear control valve that apportions steam or water to a user process. The valve regulates cooling water or steam flow depending on the process requirement resident in the temperature controller program. This package can be provided with a Precisor® positioner and Proximity position transmitter which provides an excellent process control application problem solution.

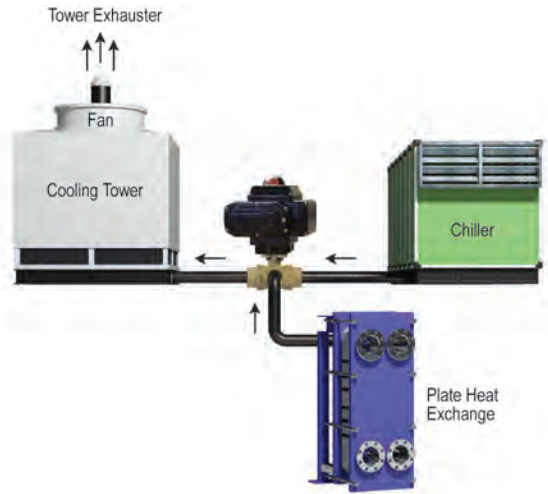

**Water-side Economizer System includes WE31 3-way ball valve for accurate control of flow.**

To ensure efficient utilization of cold water in HVAC systems, WE31 3-way ball valves are called upon to modulate flow. This common "water-side economizer" allows water from the plate heat exchanger to be diverted directly to the cooling tower if the temperature is cool enough, instead of coming directly from the condenser on the chiller.

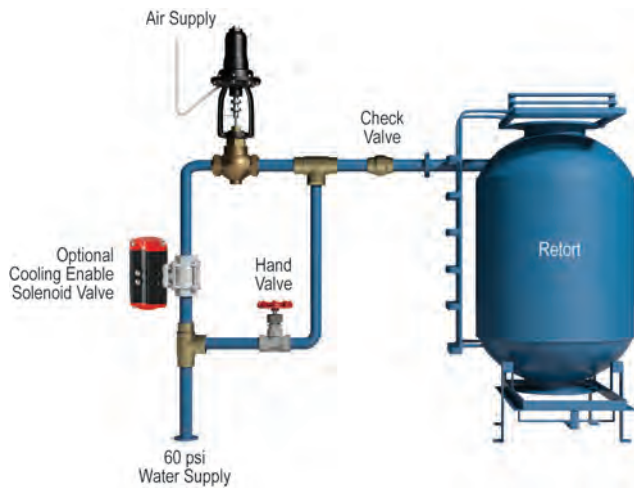

**Quick response Hi-Flow™ valves control water flow in cooling process.**

Dependable W.E. Anderson™ Hi-Flow™ control valves with Lin-E-Aire® air-to-raise actuators combine to provide unsurpassed water flow management. This retort system employs the Hi-Flow™ valve because of its excellent control capabilities, which are necessary for this application. After the cooking process, the valve is opened slowly. Once the desired temperature has been reached, the supply is shut off and any additional cooling is done by use of the hand valve.

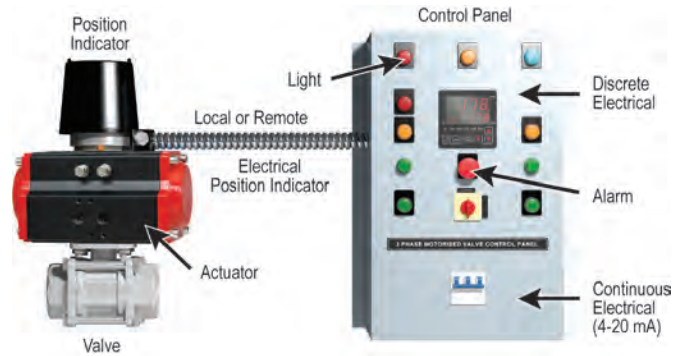

**Proximity® Mark Series valve position indicator is perfect for valve position indication on offshore oil rigs.**

Proximity® Mark Series position indicator is utilized in valve automation packages in harsh environments. The Mark Series mounts onto the top of rotary valve actuators and connects to the actuator shaft or attaches to the shaft of a linear valve for indicating valve position. Standard with the Mark Series is visual position indication with "OPEN", "CLOSED", and degree position status. The Mark Series is available with continuous position retransmission with a 4 to 20 mA output and up to six adjustable position indication switches for remote indication of valve status. Remote status transmitter is used for indication of exact valve position and switches provide discrete indication of valve open and closed status in the control room. The Mark Series is perfect for this application because of the 316 SS enclosure that withstands the sea spray environment, and the magnetic drive mechanism that completely seals the switch cavity from the environment.

# VALVE TECHNICAL INFORMATION

## TERMINOLOGY

- **Pressure Drop** – The difference in upstream and downstream pressures of the fluid flowing through the valve.
- **Critical Flow** – The flow has reached the point of being choked. At the choked condition the flow rate has hit a maximum limit and does not increase with further increase in pressure drop across the valve.
- **Cv or Valve Flow Coefficient** – The number of U. S. gallons per minute of water at 60°F that will pass through the valve with a pressure drop of 1 psi. For example, a Hi-Flow™ valve with a maximum Cv of 10.75 has an effective port area in the full open position such that it passes 10.75 GPM of water with a pressure drop of 1 psi.
- **Full Port** – The port diameter of the valve is the same diameter as the piping connections.
- **Rangeability** – The ratio of maximum controllable flow to minimum controllable flow of a valve. For example, a valve with a 50 to 1 rangeability and a total flow capacity of 100 GPM at full open controls flow accurately to as low as 2 GPM.
- **Valve Flow Characteristic** – The relationship between the stem travel or rotation of a valve, expressed in percent travel, and the fluid flow through the valve, expressed in percent of full flow.

## CONTROL VALVE SIZING



The Cv method is an accepted way to size control valves. Basic equations are provided as a guide to use in sizing a control valve, and the results of the equations will only be as accurate as the information provided of the flowing conditions. The equations are broken down into the type of media - liquid, gas or steam, and whether or not the flow is critical. The critical flow equations are to be used for vapor flow when the pressure drop across the valve is greater than half of the upstream pressure. As a general guide to avoid cavitation do not size a valve for liquid service where the pressure drop is greater than 50% of the upstream pressure.

## CONTROL VALVE ACTUATOR SIZING



## CONTROL VALVE FLOW



## NOMENCLATURE

- Cv = Valve flow coefficient
- g = Specific gravity of liquid at flowing conditions
- G = Specific gravity of gas at flowing conditions
- P1 = Upstream pressure, psia
- P2 = Downstream pressure, psia
- ΔP = Actual pressure drop (P1-P2), psi
- q = Liquid volumetric flow rate, U.S. GPM
- Q = Gas volumetric flow rate, SCFH
- W = Steam weight (mass) flow rate, LB/HR
- T = Flowing Temperature, °R (460 + °F)

Once the required Cv is determined, selection of the proper size control valve can be obtained by comparing the required Cv to the Cv values for the valve. As a general rule the maximum capacity of a control valve should be 15 to 50% above the maximum process flow, and the minimum required Cv must be within the available rangeability of the valve for proper control. If only the maximum process flow rate was used to calculate Cv, then the percent travel of the valve should be checked and should fall in the range of 65 to 80% of total travel.

## SUB-CRITICAL FLOW

$$\text{Liquid } C_v = q \left( \frac{g}{\Delta P} \right)^{1/2}$$

$$\text{Gas } C_v = \frac{Q}{963} \left( \frac{G \times T}{\Delta P (P_1 + P_2)} \right)^{1/2}$$

$$\text{Steam } C_v = \frac{W}{2.1 [\Delta P (P_1 + P_2)]^{1/2}}$$

## CRITICAL FLOW

Gas or steam where  $\Delta P > \frac{P_1}{2}$

$$C_v = \frac{Q (G \times T)^{1/2}}{750 \times P_1}$$

$$C_v = \frac{W}{1.65 \times P_1}$$

**Dwyer**

SERIES WE01 | W.E. ANDERSON™ BY DWYER

# 2-PIECE NPT STAINLESS STEEL BALL VALVES

Full Port, Vented Ball, Electric or Pneumatic Actuators



WE01-EHD00



WE01-EDA02



WE01-EDA02-AA01



WE01-ETD01-A



WE01-ETI02-A



The **Series WE01 2-Piece NPT Stainless Steel Ball Valves** incorporate a full port valve for great flow rates with minimal pressure drop. The valve features a blowout proof stem for added safety, reinforced PTFE seats and seals for longer life, and a 316 SS (ASTM CF8M) ball for better performance. Actuators are direct mounted creating a compact assembly for tight spaces. Limit switches are able to be mounted directly to the valves allowing for remote position indication.

The Series WE01 can be configured with either an electric or pneumatic actuator. Electric actuators are available in weatherproof or explosion-proof, a variety of supply voltages and two-position or modulating control. Two-position actuators use the supply voltage to drive the valve open or closed, while the modulating actuator accepts a 4 to 20 mA input for valve positioning. Actuators feature thermal overload protection and permanently lubricated gear train.

The pneumatic double acting actuator uses an air supply to drive the valve open and closed. The actuator has two supply ports, with one driving the valve open and the other driving the valve closed. Spring return pneumatic actuators use the air supply to open the valve and internally loaded springs return the valve to the closed position. Also available is the SN solenoid valve to electrically switch the air supply pressure between the air supply ports for opening and closing the valve. Actuators are constructed of anodized and epoxy coated aluminum for years of corrosion free service.

**FEATURES/BENEFITS**

- Capable of being configured to fit any application
- Limit switches can be mounted to manual valves for remote monitoring
- Vented ball to reduce operating torque
- Weatherproof or explosion-proof electric actuators
- Double acting or spring return anodized aluminum pneumatic actuators
- Full port design reduces the pressure drop across the valve

**APPLICATIONS**

- Gas or liquid flow control
- Ideal for quick bubble tight shut-off

**SPECIFICATIONS****VALVE**

**Service:** Compatible liquids and gases.

**Body:** 2-piece.

**Line Sizes:** 1/2 to 3".

**End Connections:** Female NPT.

**Pressure Limits:** 28" Hg to 1000 psi (-0.7 to 69 bar) up to 250°F.

**Wetted Materials:** Body and Ball: 316 SS (CF8M); Stem: 316 SS; Seat: RTFE/PTFE; Seal, Washer and Packing: PTFE.

**Temperature Limits:** -20 to 392°F (-29 to 200°C).

**Other Materials:** O-ring: Fluoroelastomer; Handle: 304 SS; Washer: 301 SS; Stem Nut, Locking Device, Gland Ring: 304 SS; Handle Sleeve: PVC.

**Agency Approvals:** Meets the technical requirements of EU Directive 2011/65/ EU (RoHS II).

**ACTUATORS****Pneumatic "DA" and "SR" Series**

**Type:** DA series is double acting and SR series is spring return (rack and pinion).

**Normal Supply Pressure:** DA: 40 to 115 psi (2.7 to 7.9 bar); SR: 80 psi (5.5 bar).

**Maximum Supply Pressure:** 120 psi (8.6 bar).

**Air Connections:** DA01: 1/8" female NPT; DA02 to DA05: 1/4" female NPT; SR02 to SR07: 1/4" female NPT.

**Housing Material:** Anodized aluminum body and epoxy coated aluminum end caps.

**Temperature Limits:** -40 to 176°F (-40 to 80°C).

**Accessory Mounting:** NAMUR standard.

**Electric "TD" and "MD" Series**

**Power Requirements:** 110 VAC, 220 VAC, 24 VAC or 24 VDC (MD models not available in 24 VDC).

**Power Consumption:** See instruction manual.

**Cycle Time (per 90°):** TD01 4 s; MD01: 10 s; TD02 and MD02: 20 s; TD03 and MD03: 30 s.

**Duty Rating:** 85%.

**Enclosure Rating:** NEMA 4X (IP67).

**Housing Material:** Powder coated aluminum.

**Temperature Limits:** -22 to 140°F (-30 to 60°C).

**Electrical Connection:** 1/2" female NPT.

**Modulating Input:** 4-20 mA.

**Standard Features:** Manual override, position indicator, and TD models come with two limit switches.

**Electric "TI" and "MI" Series**

**Power Requirements:** 110 VAC, 220 VAC, 24 VAC or 24 VDC.

**Power Consumption:** See instruction manual.

**Cycle Time (per 90°):** See instruction manual.

**Duty Rating:** See instruction manual.

**Enclosure Rating:** NEMA 7, designed to meet hazardous locations: Class I, Group C & D; Class II, Group E, F & G; Division I & II.

**Housing Material:** Powder coated aluminum.

**Temperature Limits:** -40 to 140°F (-40 to 60°C).

**Electrical Connection:** 1/2" female NPT.

**Modulating Input:** 4-20 mA.

**Standard Features:** Position indicator and two limit switches.



# 2-PIECE NPT STAINLESS STEEL BALL VALVES

Full Port, Vented Ball, Electric or Pneumatic Actuators

MODEL CHART						
Size	Cv (gal/min)	Popular Hand Operated Model	Popular Double Acting Pneumatic Model	Popular Spring Return Pneumatic Model	Popular NEMA 4X Two Position Electric (110 VAC) Model	Popular NEMA 4X Modulating Electric (110 VAC) Model
1/2"	36.64	WE01-CHD00	WE01-CDA01	WE01-CSR02	WE01-CTD01-A	WE01-CMD01-A
3/4"	67.69	WE01-DHD00	WE01-DDA01	WE01-DSR02	WE01-DTD01-A	WE01-DMD01-A
1"	110.27	WE01-EHD00	WE01-EDA02	WE01-ESR03	WE01-ETD01-A	WE01-EMD01-A
1-1/4"	184.73	WE01-FHD00	WE01-FDA02	WE01-FSR03	WE01-FTD01-A	WE01-FMD01-A
1-1/2"	266.62	WE01-GHD00	WE01-GDA03	WE01-GSR04	WE01-GTD02-A	WE01-GMD01-A
2"	485.3	WE01-HHD00	WE01-HDA03	WE01-HSR05	WE01-HTD02-A	WE01-HMD02-A
2-1/2"	791.57	WE01-IHD00	WE01-IDA04	WE01-ISR07	WE01-ITD03-A	WE01-IMD03-A
3"	1151.95	WE01-JHD00	WE01-JDA05	WE01-JSR07	WE01-JTD03-A	WE01-JMD03-A

MODEL CHART - HAND OPERATED & PNEUMATIC ACTUATOR						
Example	WE01	-EDA02	-A	A	01	WE01-EDA02-AA01
Series	WE01					316 SS 2-piece NPT
Size and Actuator		CHD00 DHD00 EHD00 FHD00 GHD00 HHD00 IHD00 JHD00 CDA01 DDA01 EDA02 FDA02 GDA03 HDA03 IDA04 JDA05 CSR02 DSR02 ESR03 FSR03 GSR04 HSR05 ISR07 JSR07				1/2" hand operated 3/4" hand operated 1" hand operated 1-1/4" hand operated 1-1/2" hand operated 2" hand operated 2-1/2" hand operated 3" hand operated 1/2" double acting 3/4" double acting 1" double acting 1-1/4" double acting 1-1/2" double acting 2" double acting 2-1/2" double acting 3" double acting 1/2" spring return 3/4" spring return 1" spring return 1-1/4" spring return 1-1/2" spring return 2" spring return 2-1/2" spring return 3" spring return
Solenoid			N A			No solenoid NEMA 4X NAMUR solenoid
Solenoid Voltage				N A B C D E		No solenoid 110 VAC 220 VAC 24 VAC 24 VDC 12 VDC
Positioner and Switches					00 01 02 03 04 06 07 08 09	None 42AD0 exp limit switch 45VD0 exp position transmitter 42AD0-B ATEX limit switch 42AD0-IE IECEX limit switch QV-210101 poly limit switch VPS and P1 prox switch 265ER-D5 positioner 285ER-D5 smart positioner
Options					NO	Fail open spring return actuator

ACCESSORIES	
Model	Description
AFR4	Air filter regulator 0 to 120 psi
VB-01	Volume booster

MODEL CHART - ELECTRIC ACTUATOR				
Example	WE01	-GMD01	-A	WE01-GMD01-A
Series	WE01			316 SS 2-piece NPT
Size and Actuator		CTD01 DTD01 ETD01 FTD01 GTD02 HTD02 ITD03 JTD03 CMD01 DMD01 EMD01 FMD01 GMD01 HMD02 IMD03 JMD03 CTI01 DTI01 ETI02 FTI02 GTI02 HTI04 ITI05 JTI06 CMI01 DMI01 EMI02 FMI02 GMI02 HMI04 IMI05 JMI06		1/2" NEMA 4X two-position 3/4" NEMA 4X two-position 1" NEMA 4X two-position 1-1/4" NEMA 4X two-position 1-1/2" NEMA 4X two-position 2" NEMA 4X two-position 2-1/2" NEMA 4X two-position 3" NEMA 4X two-position 1/2" NEMA 4X modulating 3/4" NEMA 4X modulating 1" NEMA 4X modulating 1-1/4" NEMA 4X modulating 1-1/2" NEMA 4X modulating 2" NEMA 4X modulating 2-1/2" NEMA 4X modulating 3" NEMA 4X modulating 1/2" exp two-position 3/4" exp two-position 1" exp two-position 1-1/4" exp two-position 1-1/2" exp two-position 2" exp two-position 2-1/2" exp two-position 3" exp two-position 1/2" exp electric modulating 3/4" exp electric modulating 1" exp electric modulating 1-1/4" exp electric modulating 1-1/2" exp electric modulating 2" exp electric modulating 2-1/2" exp electric modulating 3" exp electric modulating
Actuator Voltage			A B C D	110 VAC 220 VAC 24 VAC 24 VDC

REPAIR KIT	
Model	Valve Series and Size
VRK-02	WE01-1/2"
VRK-03	WE01-3/4"
VRK-04	WE01-1"
VRK-06	WE01-1-1/2"
VRK-07	WE01-2"
VRK-08	WE01-2-1/2"
VRK-09	WE01-3"
Parts List - Included in Kit	
1 PTFE thrust washer	
1 FKM O-ring	
2 PTFE stem packing	
2 PTFE seals	
2 RTFE seats	

# 2-PIECE NPT BRASS BALL VALVES

Full Port, Vented Ball, Electric or Pneumatic Actuators



WE08-EHD00



WE08-EDA02



WE08-ETD01-A



WE08-ETI02-A



The **Series WE08 2-Piece NPT Brass Ball Valves** incorporate a full port 2-piece brass ball valve for great flow rates with minimal pressure drop. The valve features a blowout proof stem for added safety, reinforced PTFE seats and seals for longer life, and a brass ball for better performance. Actuators are direct mounted creating a compact assembly for tight spaces.

The Series WE08 can be configured with either an electric or pneumatic actuator. Electric actuators are available in weatherproof or explosion-proof, a variety of supply voltages, and two-position or modulating control. Two-position actuators use the supply voltage to drive the valve open or closed, while the modulating actuator accepts a 4 to 20 mA input for valve positioning. Actuators feature thermal overload protection and permanently lubricated gear train.

The pneumatic double acting actuator uses an air supply to drive the valve open and closed. The actuator has two supply ports, with one driving the valve open and the other driving the valve closed. Spring return pneumatic actuators use the air supply to open the valve and internally loaded springs return the valve to the closed position. Also, between the air supply ports for opening and closing the valve, actuators are constructed of anodized and epoxy coated aluminum for years of corrosion free service.

## FEATURES/BENEFITS

- Capable of being configured to fit any application
- Limit switches can be mounted to manual valves for remote monitoring
- Vented ball to reduce operating torque
- Weatherproof or explosion-proof electric actuators
- Double acting or spring return anodized aluminum pneumatic actuators
- Full port design reduces the pressure drop across the valve

## APPLICATIONS

- Gas or liquid flow control
- Ideal for quick bubble tight shut-off

## SPECIFICATIONS

### VALVE

**Service:** Compatible liquids and gases.

**Body:** 2-piece.

**Line Sizes:** 1/2 to 2".

**End Connections:** Female NPT.

**Pressure Limits:** 600 psi (41 bar) WOG.

**Wetted Materials:** Body, ball, and stem: Brass; Seat, seal, and packing: PTFE.

**Temperature Limits:** -20 to 425°F (-30 to 220°C).

**Other Materials:** O-ring: NBR; Handle, stem nut, ferrule: SS; Handle Sleeve: Vinyl; Body and cap: Nickel plated.

**Agency Approvals:** Meets the technical requirements of EU Directive 2011/65/ EU (RoHS II).

### ACTUATORS

#### Pneumatic "DA" and "SR" Series

**Type:** DA series is a double acting and SR series is a spring return (rack and pinion).

**Normal Supply Pressure:** DA: 40 to 115 psi (2.7 to 7.9 bar); SR: 80 psi (5.5 bar).

**Maximum Supply Pressure:** 120 psi (8.6 bar).

**Air Connections:** DA02 to DA03: 1/4" female NPT; SR02 to SR04: 1/4" female NPT.

**Housing Material:** Anodized aluminum body and epoxy coated aluminum end caps.

**Temperature Limits:** -40 to 176°F (-40 to 80°C).

**Accessory Mounting:** NAMUR standard.

#### Electric "TD" and "MD" Series

**Power Requirements:** 110 VAC, 220 VAC, 24 VAC, or 24 VDC (MD models not available in 24 VDC).

**Power Consumption:** See instruction manual.

**Cycle Time (per 90°):** TD01 4 s; MD01: 10 s; TD02: 20 s).

**Duty Rating:** 85%.

**Enclosure Rating:** NEMA 4X (IP67).

**Housing Material:** Powder coated aluminum.

**Temperature Limits:** -22 to 140°F (-30 to 60°C).

**Electrical Connection:** 1/2" female NPT.

**Modulating Input:** 4-20 mA.

**Standard Features:** Manual override, position indicator, and TD models come with two limit switches.

#### Electric "TI" and "MI" Series

**Power Requirements:** 110 VAC, 220 VAC, 24 VAC, 24 VDC.

**Power Consumption:** See instruction manual.

**Cycle Time (per 90°):** See instruction manual.

**Duty Rating:** See instruction manual.

**Enclosure Rating:** NEMA 7, designed to meet hazardous locations: Class I, Group C & D; Class II, Group E, F & G; Division I & II.

**Housing Material:** Powder coated aluminum.

**Temperature Limits:** -40 to 140°F (-40 to 60°C).

**Electrical Connection:** 1/2" female NPT.

**Modulating Input:** 4-20 mA.

**Standard Features:** Position indicator and two limit switches.

# 2-PIECE NPT BRASS BALL VALVES

Full Port, Vented Ball, Electric or Pneumatic Actuators

MODEL CHART						
Size	Cv (gal/min)	Popular Hand Operated Model	Popular Double Acting Pneumatic Model	Popular Spring Return Pneumatic Model	Popular NEMA 4X Two Position Electric (110 VAC) Model	Popular NEMA 4X Modulating Electric (110 VAC) Model
1/2"	16	WE08-CHD00	WE08-CDA02	WE08-CSR02	WE08-CTD01-A	WE08-CMD01-A
3/4"	40	WE08-DHD00	WE08-DDA02	WE08-DSR03	WE08-DTD01-A	WE08-DMD01-A
1"	65	WE08-EHD00	WE08-EDA02	WE08-ESR03	WE08-ETD01-A	WE08-EMD01-A
1-1/4"	90	WE08-FHD00	WE08-FDA03	WE08-FSR03	WE08-FTD01-A	WE08-FMD01-A
1-1/2"	135	WE08-GHD00	WE08-GDA03	WE08-GSR03	WE08-GTD01-A	WE08-GMD01-A
2"	251	WE08-HHD00	WE08-HDA03	WE08-HSR04	WE08-HTD02-A	WE08-HMD01-A

MODEL CHART - HAND OPERATED & PNEUMATIC ACTUATOR						
Example	WE08	-EDA02	-A	A	01	WE08-EDA02-AA01
Series	WE08					Brass 2-piece NPT
Size and Actuator		CHD00 DHD00 EHD00 FHD00 GHD00 HHD00 CDA02 DDA02 EDA02 FDA03 GDA03 HDA03 CSR02 DSR03 ESR03 FSR03 GSR03 HSR04				1/2" hand operated 3/4" hand operated 1" hand operated 1-1/4" hand operated 1-1/2" hand operated 2" hand operated 1/2" double acting 3/4" double acting 1" double acting 1-1/4" double acting 1-1/2" double acting 2" double acting 1/2" spring return 3/4" spring return 1" spring return 1-1/4" spring return 1-1/2" spring return 2" spring return
Solenoid			N A			No solenoid NEMA 4X NAMUR solenoid
Solenoid Voltage				N A B C D E		No solenoid 110 VAC 220 VAC 24 VAC 24 VDC 12 VDC
Positioner and Switches					00 01 02 03 06 07 08 09	None 42AD0 exp limit switch 45VD0 exp position transmitter 42AD0-B ATEX limit switch QV-210101 poly limit switch VPS and P1 prox switch 265ER-D5 positioner 285ER-D5 smart positioner
Options					NO	Fail open spring return actuator

MODEL CHART - ELECTRIC ACTUATOR				
Example	WE08	-GMD01	-A	WE08-GMD01-A
Series	WE08			Brass 2-piece NPT
Size and Actuator		CTD01 DTD01 ETD01 FTD01 GTD01 HTD02 CMD01 DMD01 EMD01 FMD01 GMD01 HMD01 CTI01 DTI01 ETI02 FTI02 GTI02 HTI03 CMI01 DMI01 EMI02 FMI02 GMI02 HMI03		1/2" electric two-position 3/4" electric two-position 1" electric two-position 1-1/4" electric two-position 1-1/2" electric two-position 2" electric two-position 1/2" electric modulating 3/4" electric modulating 1" electric modulating 1-1/4" electric modulating 1-1/2" electric modulating 2" electric modulating 1/2" exp electric two-position 3/4" exp electric two-position 1" exp electric two-position 1-1/4" exp electric two-position 1-1/2" exp electric two-position 2" exp electric two-position 1/2" exp electric two-position 3/4" exp electric two-position 1" exp electric two-position 1-1/4" exp electric two-position 1-1/2" exp electric two-position 2" exp electric two-position
Actuator Voltage			A B C D	110 VAC 220 VAC 24 VAC 24 VDC

ACCESSORIES	
Model	Description
AFR4	Air filter regulator, 0 to 120 psi

# 3-PIECE NPT STAINLESS STEEL BALL VALVES

Full Port, Vented Ball, Electric or Pneumatic Actuators

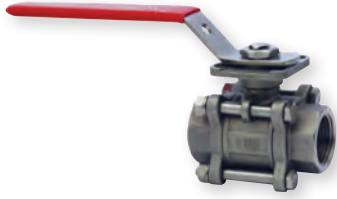

WE02-DHD00



WE02-DDA01



WE02-DDA01-AA01



WE02-DTD01-A



WE02-CTI01-A



The Series WE02 3-Piece NPT Stainless Steel Ball Valves incorporate a full port valve for great flow rates with minimal pressure drop. The valve features a blowout proof stem for added safety, reinforced PTFE seats and seals for longer life, and a 316 SS (ASTM CF8M) ball for better performance. Actuators are direct mounted creating a compact assembly for tight spaces. Limit switches are able to be mounted directly to the valves allowing for remote position indication.

The Series WE02 can be configured with either an electric or pneumatic actuator. Electric actuators are available in weatherproof or explosion-proof, a variety of supply voltages and two-position or modulating control. Two-position actuators use the supply voltage to drive the valve open or closed, while the modulating actuator accepts a 4 to 20 mA input for valve positioning. Actuators feature thermal overload protection and permanently lubricated gear train.

The pneumatic double acting actuator uses an air supply to drive the valve open and closed. The actuator has two supply ports, with one driving the valve open and the other driving the valve closed. Spring return pneumatic actuators use the air supply to open the valve, and internally loaded springs return the valve to the closed position. Also available is the SN solenoid valve to electrically switch the air supply pressure between the air supply ports for opening and closing the valve. Actuators are constructed of anodized and epoxy coated aluminum for years of corrosion free service.

## FEATURES/BENEFITS

- Capable of being configured to fit any application
- Limit switches can be mounted to manual valves for remote monitoring
- Vented ball to reduce operating torque
- Weatherproof or explosion-proof electric actuators
- Double acting or spring return anodized aluminum pneumatic actuators
- 3-piece design for each replacement of seals
- Full port design reduces the pressure drop across the valve

## APPLICATIONS

- Gas or liquid flow control
- Ideal for quick bubble tight shut-off

## SPECIFICATIONS

### VALVE

**Service:** Compatible liquids and gases.

**Body:** 3-piece.

**Line Sizes:** 1/2 to 3" .

**End Connections:** Female NPT.

**Pressure Limits:** 28" Hg to 1000 psi (-0.7 to 69 bar) up to 250°F.

**Wetted Materials:** Body and ball: 316 SS (CF8M); Stem: 316 SS; Seat: RTFE/PTFE; Seal, Washer, and Packing: PTFE.

**Temperature Limits:** -20 to 392°F (-29 to 200°C).

**Other Materials:** O-ring:

Fluoroelastomer; Handle: 304 SS; Washer: 301 SS; Stem Nut, Locking Device, Gland Ring: 304 SS; Handle Sleeve: PVC.

**Agency Approvals:** Meets the technical requirements of EU Directive 2011/65/ EU (RoHS II).

### ACTUATORS

#### Pneumatic "DA" and "SR" Series

**Type:** DA series is double acting and SR series is spring return (rack and pinion).

**Normal Supply Pressure:** DA: 40 to 115 psi (2.7 to 7.9 bar); SR: 80 psi (5.5 bar).

**Maximum Supply Pressure:** 120 psi (8.6 bar).

**Air Connections:** DA01: 1/8" female NPT; DA02 to DA05: 1/4" female NPT; SR02 to SR07: 1/4" female NPT.

**Housing Material:** Anodized aluminum body and epoxy coated aluminum end caps.

**Temperature Limits:** -40 to 176°F (-40 to 80°C).

**Accessory Mounting:** NAMUR standard.

#### Electric "TD" and "MD" Series

**Power Requirements:** 110 VAC, 220 VAC, 24 VAC or 24 VDC (MD models not available in 24 VDC).  
**Power Consumption:** See instruction manual.

**Cycle Time (per 90°):** TD01: 4 s; MD01: 10 s; TD02 and MD02: 20 s; TD03 and MD03: 30 s.

**Duty Rating:** 85%.

**Enclosure Rating:** NEMA 4X (IP67).

**Housing Material:** Powder coated aluminum.

**Temperature Limits:** -22 to 140°F (-30 to 60°C).

**Electrical Connection:** 1/2" female NPT.

**Modulating Input:** 4-20 mA.

**Standard Features:** Manual override, position indicator, and TD models come with two limit switches.

#### Electric "TI" and "MI" Series

**Power Requirements:** 110 VAC, 220 VAC, 24 VAC or 24 VDC.

**Power Consumption:** See instruction manual.

**Cycle Time (per 90°):** See instruction manual.

**Duty Rating:** See instruction manual.

**Enclosure Rating:** NEMA 7, designed to meet hazardous locations: Class I, Group C & D; Class II, Group E, F & G; Division I & II.

**Housing Material:** Powder coated aluminum.

**Temperature Limits:** -40 to 140°F (-40 to 60°C).

**Electrical Connection:** 1/2" female NPT.

**Modulating Input:** 4-20 mA.

**Standard Features:** Position indicator and two limit switches.



# 3-PIECE NPT STAINLESS STEEL BALL VALVES

Full Port, Vented Ball, Electric or Pneumatic Actuators

MODEL CHART						
Size	Cv (gal/min)	Popular Hand Operated Model	Popular Double Acting Pneumatic Model	Popular Spring Return Pneumatic Model	Popular NEMA 4X Two Position Electric (110 VAC) Model	Popular NEMA 4X Modulating Electric (110 VAC) Model
1/2"	36.64	WE02-CHD00	WE02-CDA01	WE02-CSR02	WE02-CTD01-A	WE02-CMD01-A
3/4"	67.69	WE02-DHD00	WE02-DDA01	WE02-DSR02	WE02-DTD01-A	WE02-DMD01-A
1"	110.27	WE02-EHD00	WE02-EDA02	WE02-ESR03	WE02-ETD01-A	WE02-EMD01-A
1-1/4"	184.73	WE02-FHD00	WE02-FDA02	WE02-FSR03	WE02-FTD01-A	WE02-FMD01-A
1-1/2"	266.62	WE02-GHD00	WE02-GDA03	WE02-GSR04	WE02-GTD02-A	WE02-GMD01-A
2"	485.3	WE02-HHD00	WE02-HDA03	WE02-HSR05	WE02-HTD02-A	WE02-HMD02-A
2-1/2"	791.57	WE02-IHD00	WE02-IDA04	WE02-ISR07	WE02-ITD03-A	WE02-IMD03-A
3"	1151.95	WE02-JHD00	WE02-JDA05	WE02-JSR07	WE02-JTD03-A	WE02-JMD03-A

MODEL CHART - HAND OPERATED & PNEUMATIC ACTUATOR						
Example	WE02	-CSR02	-N	N	09	WE02-CSR02-NN09
Series	WE02					316 SS 3-piece NPT
Size and Actuator		CHD00				1/2" hand operated
		DHD00				3/4" hand operated
		EHD00				1" hand operated
		FHD00				1-1/4" hand operated
		GHD00				1-1/2" hand operated
		HHD00				2" hand operated
		IHD00				2-1/2" hand operated
		JHD00				3" hand operated
		CDA01				1/2" double acting
		DDA01				3/4" double acting
		EDA02				1" double acting
		FDA02				1-1/4" double acting
		GDA03				1-1/2" double acting
		HDA03				2" double acting
		IDA04				2-1/2" double acting
		JDA05				3" double acting
	Solenoid		CSR02			
		DSR02				3/4" spring return
		ESR03				1" spring return
		FSR03				1-1/4" spring return
		GSR04				1-1/2" spring return
		HSR05				2" spring return
		ISR07				2-1/2" spring return
		JSR07				3" spring return
			N			No solenoid
			A			NEMA 4X NAMUR solenoid
Solenoid Voltage				N		No solenoid
				A		110 VAC
				B		220 VAC
				C		24 VAC
				D		24 VDC
Positioner and Switches					00	None
					01	42AD0 exp limit switch
					02	45VD0 exp position transmitter
					03	42AD0-B ATEX limit switch
					04	42AD0-IE IECEX limit switch
					06	QV-210101 poly limit switch
					07	VPS and P1 prox switch
Options					08	265ER-D5 positioner
					09	285ER-D5 smart positioner
					NO	Fail open spring return actuator

ACCESSORIES	
Model	Description
AFR4	Air filter regulator 0 to 120 psi
VB-01	Volume booster

MODEL CHART - ELECTRIC ACTUATOR				
Example	WE02	-ETD01	-B	WE02-ETD01-B
Series	WE02			316 SS 3-piece NPT
Size and Actuator		CTD01		1/2" NEMA 4X two-position
		DTD01		3/4" NEMA 4X two-position
		ETD01		1" NEMA 4X two-position
		FTD01		1-1/4" NEMA 4X two-position
		GTD02		1-1/2" NEMA 4X two-position
		HTD02		2" NEMA 4X two-position
		ITD03		2-1/2" NEMA 4X two-position
		JTD03		3" NEMA 4X two-position
		CMD01		1/2" NEMA 4X modulating
		DMD01		3/4" NEMA 4X modulating
		EMD01		1" NEMA 4X modulating
		FMD01		1-1/4" NEMA 4X modulating
		GMD01		1-1/2" NEMA 4X modulating
		HMD02		2" NEMA 4X modulating
		IMD03		2-1/2" NEMA 4X modulating
		JMD03		3" NEMA 4X modulating
		CTI01		1/2" exp two-position
		DTI01		3/4" exp two-position
		ETI02		1" exp two-position
		FTI02		1-1/4" exp two-position
		GTI03		1-1/2" exp two-position
		HTI04		2" exp two-position
		ITI05		2-1/2" exp two-position
		JTI05		3" exp two-position
		CMI01		1/2" exp electric modulating
	DMI01		3/4" exp electric modulating	
	EMI02		1" exp electric modulating	
	FMI02		1-1/4" exp electric modulating	
	GMI03		1-1/2" exp electric modulating	
	HMI04		2" exp electric modulating	
	IMI05		2-1/2" exp electric modulating	
	JMI05		3" exp electric modulating	
Actuator Voltage			A	110 VAC
			B	220 VAC
			C	24 VAC
			D	24 VDC

REPAIR KIT	
Model	Valve Series and Size
VRK-10	WE02-1/2"
VRK-11	WE02-3/4"
VRK-12	WE02-1"
VRK-14	WE02-1-1/2"
VRK-15	WE02-2"
VRK-16	WE02-2-1/2"
VRK-17	WE02-3"
Parts List - Included in Kit	
1 PTFE thrust washer	
1 FKM O-ring	
2 PTFE stem packing	
2 PTFE seals	
2 RTFE seats	

**Dwyer**

SERIES WE03 | W.E. ANDERSON™ BY DWYER

# 3-PIECE TRI-CLAMP STAINLESS STEEL BALL VALVES

Cavity Filled, Full Port, Electric or Pneumatic Actuators



WE03-DHD00

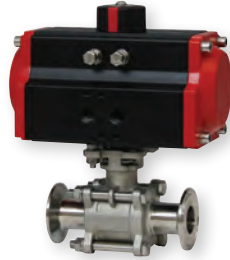

WE03-DDA01

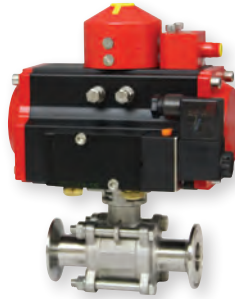

WE03-DDA01-AA07



WE03-DDA01-AA06



WE03-DTD01-A



The **Series WE03 3-Piece Tri-Clamp Stainless Steel Ball Valves** incorporate a full port 3-piece tri-clamp SS ball valve for great flow rates with minimal pressure drop. The valve features a blowout proof stem for added safety, reinforced PTFE seats and seals for longer life, and a 316 SS (ASTM CF8M) ball for better performance. Actuators are direct mounted creating a compact assembly for tight spaces. Limit switches are able to be mounted directly to the valves allowing for remote position indication.

The Series WE03 can be configured with either an electric or pneumatic actuator. Electric actuators are available in weatherproof or explosion-proof, a variety of supply voltages and two-position or modulating control. Two-position actuators use the supply voltage to drive the valve open or closed, while the modulating actuator accepts a 4 to 20 mA input for valve positioning. Actuators feature thermal overload protection and permanently lubricated gear train.

The pneumatic double acting actuator uses an air supply to drive the valve open and closed. The actuator has two supply ports with one driving the valve open and the other driving the valve closed. Spring return pneumatic actuators use the air supply to open the valve and internally loaded springs return the valve to the closed position. Also available is the SN solenoid valve to electrically switch the air supply pressure between the air supply ports for opening and closing the valve. Actuators are constructed of anodized and epoxy coated aluminum for years of corrosion free service.

## FEATURES/BENEFITS

- Capable of being configured to fit any application
- Limit switches can be mounted to manual valves for remote monitoring
- Cavity filled valve for sanitary applications
- Weatherproof or explosion-proof electric actuators
- Double acting or spring return anodized aluminum pneumatic actuators
- Full port design reduces the pressure drop across the valve

## APPLICATIONS

- Gas or liquid flow control
- Ideal for quick bubble tight shut-off
- Designed for food and beverage applications

## SPECIFICATIONS

### VALVE

**Service:** Compatible liquids and gases.

**Body:** 3-piece.

**Line Sizes:** 1/2 to 2" .

**End Connections:** Tri-clamp ends.

**Pressure Limits:** 28" Hg to 1000 psi (-0.7 to 69 bar) up to 250°F.

**Wetted Materials:** Body and ball: 316 SS (CF8M); Stem: 316 SS; Seat: RTFE/PTFE; Seal, Washer, and Packing: PTFE.

**Temperature Limits:** -20 to 392°F (-29 to 200°C).

**Other Materials:** O-ring:

Fluoroelastomer; Handle: 304 SS; Washer: 301 SS; Stem Nut, Locking Device, Gland Ring: 304 SS; Handle Sleeve: PVC.

**Agency Approvals:** Meets the technical requirements of EU Directive 2011/65/ EU (RoHS II).

### ACTUATORS

**Pneumatic "DA" and "SR" Series**

**Type:** DA series is double acting and SR series is spring return (rack and pinion).

**Normal Supply Pressure:** DA: 40 to 115 psi (2.7 to 7.9 bar); SR: 80 psi (5.5 bar).

**Maximum Supply Pressure:** 120 psi (8.6 bar).

**Air Connections:** DA01: 1/8" female NPT; DA02: 1/4" female NPT; SR02 to SR04: 1/4" female NPT.

**Housing Material:** Anodized aluminum body and epoxy coated aluminum end caps.

**Temperature Limits:** -40 to 176°F (-40 to 80°C).

**Accessory Mounting:** NAMUR standard.

**Electric "TD" and "MD" Series**

**Power Requirements:** 110 VAC, 220 VAC, 24 VAC or 24 VDC (MD models not available in 24 VDC).  
**Power Consumption:** See instruction manual.

**Cycle Time (per 90°):** TD01: 4 s; MD01: 10 s; TD02 and MD02: 20 s.

**Duty Rating:** 85%.

**Enclosure Rating:** NEMA 4X (IP67).

**Housing Material:** Powder coated aluminum.

**Temperature Limits:** -22 to 140°F (-30 to 60°C).

**Electrical Connection:** 1/2" female NPT.

**Modulating Input:** 4-20 mA.

**Standard Features:** Manual override, position indicator, and TD models come with two limit switches.

**Electric "TI" and "MI" Series**

**Power Requirements:** 110 VAC, 220 VAC, 24 VAC or 24 VDC.

**Power Consumption:** See instruction manual.

**Cycle Time (per 90°):** See instruction manual.

**Duty Rating:** See instruction manual.

**Enclosure Rating:** NEMA 7, designed to meet hazardous locations: Class I, Group C & D; Class II, Group E, F & G; Division I & II.

**Housing Material:** Powder coated aluminum.

**Temperature Limits:** -40 to 140°F (-40 to 60°C).

**Electrical Connection:** 1/2" female NPT.

**Modulating Input:** 4-20 mA.

**Standard Features:** Position indicator and two limit switches.

# 3-PIECE TRI-CLAMP STAINLESS STEEL BALL VALVES

Cavity Filled, Full Port, Electric or Pneumatic Actuators

MODEL CHART						
Size	Cv (gal/min)	Popular Hand Operated Model	Popular Double Acting Pneumatic Model	Popular Spring Return Pneumatic Model	Popular NEMA 4X Two Position Electric (110 VAC) Model	Popular NEMA 4X Modulating Electric (110 VAC) Model
1/2"	14.39	WE03-CHD00	WE03-CDA01	WE03-CSR02	WE03-CTD01-A	WE03-CMD01-A
3/4"	42.25	WE03-DHD00	WE03-DDA01	WE03-DSR02	WE03-DTD01-A	WE03-DMD01-A
1"	86.17	WE03-EHD00	WE03-EDA02	WE03-ESR03	WE03-ETD01-A	WE03-EMD01-A
1-1/2"	223.61	WE03-GHD00	WE03-GDA02	WE03-GSR04	WE03-GTD01-A	WE03-GMD01-A
2"	437.98	WE03-HHD00	WE03-HDA02	WE03-HSR04	WE03-HTD02-A	WE03-HMD02-A

MODEL CHART - HAND OPERATED & PNEUMATIC ACTUATOR						
Example	WE03	-EDA02	-A	A	06	WE03-EDA02-AA06
Series	WE03					316 SS 3-piece tri-clamp
Size and Actuator		CHD00				1/2" hand operated
		DHD00				3/4" hand operated
		EHD00				1" hand operated
		GHD00				1-1/2" hand operated
		HHD00				2" hand operated
		CDA01				1/2" double acting
		DDA01				3/4" double acting
		EDA02				1" double acting
		GDA02				1-1/2" double acting
		HDA02				2" double acting
		CSR02				1/2" spring return
		DSR02				3/4" spring return
		ESR03				1" spring return
		GSR04				1-1/2" spring return
	HSR04				2" spring return	
Solenoid			N			No solenoid
			A			NEMA 4X NAMUR solenoid
Solenoid Voltage				N		No solenoid
				A		110 VAC
				B		220 VAC
				C		24 VAC
				D		24 VDC
Positioner and Switches					00	None
					01	42AD0 exp limit switch
					02	45VD0 exp position transmitter
					03	42AD0-B ATEX limit switch
					04	42AD0-IE IECEX limit switch
					06	QV-210101 poly limit switch
					07	VPS and P1 prox switch
Options					08	265ER-D5 positioner
					09	285ER-D5 smart positioner
					NO	Fail open spring return actuator

ACCESSORIES	
Model	Description
AFR4	Air filter regulator 0 to 120 psi
VB-01	Volume booster

MODEL CHART - ELECTRIC ACTUATOR				
Example	WE03	-CMD01	-A	WE03-CMD01-A
Series	WE03			316 SS 3-piece tri-clamp
Size and Actuator		CTD01		1/2" NEMA 4X two-position
		DTD01		3/4" NEMA 4X two-position
		ETD01		1" NEMA 4X two-position
		GTD01		1-1/2" NEMA 4X two-position
		HTD02		2" NEMA 4X two-position
		CMD01		1/2" NEMA 4X modulating
		DMD01		3/4" NEMA 4X modulating
		EMD01		1" NEMA 4X modulating
		GMD01		1-1/2" NEMA 4X modulating
		HMD02		2" NEMA 4X modulating
		CTI01		1/2" exp two-position
		DTI01		3/4" exp two-position
		ETI02		1" exp two-position
		GTI02		1-1/2" exp two-position
		HTI02		2" exp two-position
	Actuator Voltage			A
			B	220 VAC
			C	24 VAC
			D	24 VDC

REPAIR KIT	
Model	Valve Series and Size
VRK-19	WE03-1/2"
VRK-20	WE03-3/4"
VRK-21	WE03-1"
VRK-22	WE03-1-1/2"
VRK-23	WE03-2"
Parts List - Included in Kit	
1 PTFE thrust washer	
1 FKM O-ring	
2 PTFE stem packing	
2 PTFE seats	

# 2-PIECE FLANGED STAINLESS STEEL BALL VALVES

## 150# ANSI Flange, Vented Ball, Electric or Pneumatic Actuators



WE04-DHD00



WE04-DDA02-AA03



WE04-DDA02-NN09



WE04-DTD01-A



WE04-CTI01-A



The **Series WE04 2-Piece Flanged Stainless Steel Ball Valves** incorporate a full port 2-piece flanged SS ball valve for great flow rates with minimal pressure drop. The valve features a blowout proof stem for added safety, reinforced PTFE seats and seals for longer life, and a 316 SS (ASTM CF8M) ball for better performance. Actuators are direct mounted creating a compact assembly for tight spaces. Limit switches are able to be mounted directly to the valves allowing for remote position indication.

The Series WE04 can be configured with either a pneumatic or electric actuator. Electric actuators are available in weatherproof or explosion-proof, a variety of supply voltages, and two-position or modulating control. Two-position actuators use the supply voltage to drive the valve open or closed, while the modulating actuator accepts a 4 to 20 mA input for valve positioning. Actuators feature thermal overload protection and permanently lubricated gear train.

The pneumatic double acting actuator uses an air supply to drive the valve open and closed. The actuator has two supply ports, with one driving the valve open, and the other driving the valve closed. Spring return pneumatic actuators use the air supply to open the valve, and internally loaded springs return the valve to the closed position. Also available is the SN solenoid valve to electrically switch the air supply pressure between the air supply ports for opening and closing the valve. Actuators are constructed of anodized and epoxy coated aluminum for years of corrosion free service.

### FEATURES/BENEFITS

- Capable of being configured to fit any application
- Limit switches can be mounted to manual valves for remote monitoring
- Vented ball to reduce operating torque
- Weatherproof or explosion-proof electric actuators
- Double acting or spring return anodized aluminum pneumatic actuators
- Eliminates threads and reduces installation and maintenance time
- Full port design reduces the pressure drop across the valve

### APPLICATIONS

- Gas or liquid flow control
- Ideal for quick bubble tight shut-off

### SPECIFICATIONS

#### VALVE

**Service:** Compatible liquids and gases.

**Body:** 2-piece.

**Line Sizes:** 1/2 to 3" .

**End Connections:** 150# ANSI flange.

**Pressure Limits:** 28" Hg to 275 psi (-0.7 to 19 bar) up to 392°F.

**Wetted Materials:** Body and ball: 316 SS (CF8M); Stem: 316 SS; Seat: RTFE/PTFE; Seal, Washer, and Packing: PTFE.

**Temperature Limits:** -20 to 392°F (-29 to 200°C).

**Other Materials:** O-ring:

Fluoroelastomer; Handle: 304 SS; Washer: 301 SS; Stem Nut, Locking Device, Gland Ring: 304 SS; Handle Sleeve: PVC.

**Agency Approvals:** Meets the technical requirements of EU Directive 2011/65/ EU (RoHS II).

#### ACTUATORS

##### Pneumatic "DA" and "SR" Series

**Type:** DA series is double acting and SR series is spring return (rack and pinion).

**Normal Supply Pressure:** DA: 40 to 115 psi (2.7 to 7.9 bar); SR: 80 psi (5.5 bar).

**Maximum Supply Pressure:** 120 psi (8.6 bar).

**Air Connections:** DA01: 1/8" female NPT; DA02 to DA04: 1/4" female NPT; SR02 to SR06: 1/4" female NPT.

**Housing Material:** Anodized aluminum body and epoxy coated aluminum end caps.

**Temperature Limits:** -40 to 176°F (-40 to 80°C).

**Accessory Mounting:** NAMUR standard.

##### Electric "TD" and "MD" Series

**Power Requirements:** 110 VAC, 220 VAC, 24 VAC OR 240 VDC (MD models not available in 24 VDC) .

**Power Consumption:** See instruction manual.

**Cycle Time (per 90°):** TD01: 4 s; MD01: 10 s; TD02 and MD02: 20 s; TD03 and MD03: 30 s.

**Duty Rating:** 85%.

**Enclosure Rating:** NEMA 4X (IP67).

**Housing Material:** Powder coated aluminum.

**Temperature Limits:** -22 to 140°F (-30 to 60°C).

**Electrical Connection:** 1/2" female NPT.

**Modulating Input:** 4-20 mA.

**Standard Features:** Manual override, position indicator, and TD models come with two limit switches.

##### Electric "TI" and "MI" Series

**Power Requirements:** 110 VAC, 220 VAC, 24 VAC or 24 VDC.

**Power Consumption:** See instruction manual.

**Cycle Time (per 90°):** See instruction manual.

**Duty Rating:** See instruction manual.

**Enclosure Rating:** NEMA 7, designed to meet hazardous locations: Class I, Group C & D; Class II, Group E, F & G; Division I & II.

**Housing Material:** Powder coated aluminum.

**Temperature Limits:** -40 to 140°F (-40 to 60°C).

**Electrical Connection:** 1/2" NPT female.

**Modulating Input:** 4-20 mA.

**Standard Features:** Position indicator and two limit switches.



# 2-PIECE FLANGED STAINLESS STEEL BALL VALVES

150# ANSI Flange, Vented Ball, Electric or Pneumatic Actuators

MODEL CHART						
Size	Cv (gal/min)	Popular Hand Operated Model	Popular Double Acting Pneumatic Model	Popular Spring Return Pneumatic Model	Popular NEMA 4X Two Position Electric (110 VAC) Model	Popular NEMA 4X Modulating Electric (110 VAC) Model
1/2"	36.64	WE04-CHD00	WE04-CDA01	WE04-CSR02	WE04-CTD01-A	WE04-CMD01-A
3/4"	67.69	WE04-DHD00	WE04-DDA01	WE04-DSR02	WE04-DTD01-A	WE04-DMD01-A
1"	101.63	WE04-EHD00	WE04-EDA03	WE04-ESR03	WE04-ETD01-A	WE04-EMD01-A
1-1/2"	266.62	WE04-GHD00	WE04-GDA03	WE04-GSR04	WE04-GTD02-A	WE04-GMD01-A
2"	485.3	WE04-HHD00	WE04-HDA03	WE04-HSR05	WE04-HTD02-A	WE04-HMD02-A
2-1/2"	816.9	WE04-IHD00	WE04-IDA04	WE04-ISR06	WE04-ITD03-A	WE04-IMD03-A
3"	1121.84	WE04-JHD00	WE04-JDA04	WE04-JSR06	WE04-JTD03-A	WE04-JMD03-A

MODEL CHART - HAND OPERATED & PNEUMATIC ACTUATOR						
Example	WE04	-GDA03	-A	B	05	WE04-GDA03-AB05
Series	WE04					316 SS 2-piece flanged
Size and Actuator		CHD00				1/2" hand operated
		DHD00				3/4" hand operated
		EHD00				1" hand operated
		GHD00				1-1/2" hand operated
		HHD00				2" hand operated
		IHD00				2-1/2" hand operated
		JHD00				3" hand operated
		CDA01				1/2" double acting
		DDA01				3/4" double acting
		EDA03				1" double acting
		GDA03				1-1/2" double acting
		HDA03				2" double acting
		IDA04				2-1/2" double acting
		JDA04				3" double acting
		CSR02				1/2" spring return
		DSR02				3/4" spring return
		ESR03				1" spring return
		GSR04				1-1/2" spring return
		HSR05				2" spring return
		ISR06				2-1/2" spring return
		JSR06				3" spring return
Solenoid			N			No solenoid
			A			NEMA 4X NAMUR solenoid
Solenoid Voltage				N		No solenoid
				A		110 VAC
				B		220 VAC
				C		24 VAC
				D		24 VDC
				E		12 VDC
Positioner and Switches					00	None
					01	42AD0 exp limit switch
					02	45VD0 exp position transmitter
					03	42AD0-B ATEX limit switch
					04	42AD0-IE IECEX limit switch
					06	QV-210101 poly limit switch
					07	VPS and P1 prox switch
					08	265ER-D5 positioner
					09	285ER-D5 smart positioner
Options					NO	Fail open spring return actuator

ACCESSORIES	
Model	Description
AFR4	Air filter regulator 0 to 120 psi
VB-01	Volume booster

MODEL CHART - ELECTRIC ACTUATOR				
Example	WE04	-ITD03	-B	WE04-ITD03-B
Series	WE04			316 SS 2-piece flanged
Size and Actuator		CTD01		1/2" NEMA 4X two-position
		DTD01		3/4" NEMA 4X two-position
		ETD01		1" NEMA 4X two-position
		GTD02		1-1/2" NEMA 4X two-position
		HTD02		2" NEMA 4X two-position
		ITD03		2-1/2" NEMA 4X two-position
		JTD03		3" NEMA 4X two-position
		CMD01		1/2" NEMA 4X modulating
		DMD01		3/4" NEMA 4X modulating
		EMD01		1" NEMA 4X modulating
		GMD01		1-1/2" NEMA 4X modulating
		HMD02		2" NEMA 4X modulating
		IMD03		2-1/2" NEMA 4X modulating
		JMD03		3" NEMA 4X modulating
		CTI01		1/2" exp two-position
		DTI01		3/4" exp two-position
		ETI02		1" exp two-position
		GTI03		1-1/2" exp two-position
		HTI04		2" exp two-position
		ITI04		2-1/2" exp two-position
		JTI05		3" exp two-position
		CMI01		1/2" exp electric modulating
		DMI01		3/4" exp electric modulating
		EMI02		1" exp electric modulating
		GMI03		1-1/2" exp electric modulating
		HMI04		2" exp electric modulating
		IMI04		2-1/2" exp electric modulating
		JMI05		3" exp electric modulating
Actuator Voltage			A	110 VAC
			B	220 VAC
			C	24 VAC
			D	24 VDC

REPAIR KIT	
Model	Valve Series and Size
VRK-27	WE04-1/2"
VRK-28	WE04-3/4"
VRK-29	WE04-1"
VRK-31	WE04-1-1/2"
VRK-32	WE04-2"
VRK-33	WE04-2-1/2"
VRK-34	WE04-3"
Parts List - Included in Kit	
1 PTFE thrust washer	
1 FKM O-ring	
2 PTFE stem packing	
2 PTFE seals	
2 RTFE seats	

# 3-PIECE SOCKET WELD STAINLESS STEEL BALL VALVES

Full Port, Vented Ball, Electric or Pneumatic Actuators



WE05-EHD00



WE05-FDA02



WE05-DDA01-AA01



WE05-JTD03-A



WE05-ITI05-B



The Series WE05 3-Piece Socket Weld Stainless Steel Ball Valves offer the best possible design for socket weld ball valves. The swing out body feature and seat arrangement allow for trouble-free welding installation. The Series WE05 incorporates a full port 3-piece SS ball valve for ideal flow rates with minimal pressure drop. The valve features a blowout proof stem for added safety, reinforced PTFE seats and seals for longer life, and a 316 SS (ASTM CF8M) ball for better performance.

Actuators are directly mounted creating a compact assembly for tight spaces. Limit switches can be mounted directly to the valves, allowing for remote position indication. The Series WE05 can be configured with either an electric or pneumatic actuator. Electric actuators are available in weatherproof or explosion-proof, a variety of supply voltages and two-position modulating control. Two-position actuators use the supply voltage to drive the valve open or close, while the modulating actuator accepts a 4 to 20 mA input for valve positioning. Actuators feature thermal overload protection and a permanently lubricated gear train.

The pneumatic double acting actuator uses an air supply to drive the valve open and closed. The actuator has two supply ports with one driving the valve open and the other driving the valve closed. Spring return pneumatic actuators use the air supply to open the valve and internally loaded springs return the valve to the closed position. Also available is the SV3 solenoid valve to electrically switch the air supply pressure between the air supply ports for opening and closing the valve. Actuators are constructed of anodized and epoxy coated aluminum for years of corrosion free service.

## FEATURES/BENEFITS

- Socket weld ends
- Capable of being configured to fit any application
- Limit switches can be mounted to manual valves for remote monitoring
- Available with a variety of electric and pneumatic actuators

## APPLICATIONS

- Gas or liquid flow control

## SPECIFICATIONS

### VALVE

**Service:** Compatible liquids and gases.

**Body:** 3-piece.

**Line Sizes:** 1/2 to 3".

**End Connections:** Socket weld.

**Pressure Limits:** 20" Hg to 1000 psi (-0.7 to 69 bar) up to 250°F.

**Wetted Materials:** Body and ball: 316 SS (CF8M); Stem: 316 SS; Seat: RTFE/PTFE; Seal, Washer, and Packing: PTFE.

**Temperature Limits:** -20 to 392°F (-29 to 200°C).

**Other Materials:** O-ring:

Fluoroelastomer; Handle: 304 SS; Washer: 301 SS; Stem Nut, Locking Device, Gland Ring: 304 SS; Handle Sleeve: PVC.

**Agency Approvals:** Meets the technical requirements of EU Directive 2011/65/ EU (RoHS II).

### ACTUATORS

#### Pneumatic "DA" and "SR" Series

**Type:** DA series is double acting and SR series is spring return (rack and pinion).

**Normal Supply Pressure:** DA: 40 to 115 psi (2.7 to 7.9 bar); SR: 80 psi (5.5 bar).

**Maximum Supply Pressure:** 120 psi (8.6 bar).

**Air Connections:** DA01: 1/8" female NPT; DA02 to DA05: 1/4" female NPT; SR02 to SR07: 1/4" female NPT.

**Housing Material:** Anodized aluminum body and epoxy coated aluminum end caps.

**Temperature Limits:** -40 to 176°F (-40 to 80°C).

**Accessory Mounting:** NAMUR standard.

#### Electric "TD" and "MD" Series

**Power Requirements:** 110 VAC, 220 VAC, 24 VAC or 24 VDC (MD models not available in 24 VDC).

**Power Consumption:** See instruction manual.

**Cycle Time (per 90°):** TD01: 4 s; MD01: 10 s; TD02 and MD02: 20 s; TD03 and MD03: 30 s.

**Duty Rating:** 85%.

**Enclosure Rating:** NEMA 4X (IP67).

**Housing Material:** Powder coated aluminum.

**Temperature Limits:** -22 to 140°F (-30 to 60°C).

**Electrical Connection:** 1/2" female NPT.

**Modulating Input:** 4-20 mA.

**Standard Features:** Manual override, position indicator, and TD models come with two limit switches.

#### Electric "TI" and "MI" Series

**Power Requirements:** 110 VAC, 220 VAC, 24 VAC or 24 VDC.

**Power Consumption:** See instruction manual.

**Cycle Time (per 90°):** See instruction manual.

**Duty Rating:** See instruction manual.

**Enclosure Rating:** NEMA 7, designed to meet hazardous locations: Class I, Group C & D; Class II, Group E, F & G; Division I & II.

**Housing Material:** Powder coated aluminum.

**Temperature Limits:** -40 to 140°F (-40 to 60°C).

**Electrical Connection:** 1/2" female NPT.

**Modulating Input:** 4-20 mA.

**Standard Features:** Position indicator and two limit switches.

# 3-PIECE SOCKET WELD STAINLESS STEEL BALL VALVES

Full Port, Vented Ball, Electric or Pneumatic Actuators

MODEL CHART						
Size	Cv (gal/min)	Popular Hand Operated Model	Popular Double Acting Pneumatic Model	Popular Spring Return Pneumatic Model	Popular NEMA 4X Two Position Electric (110 VAC) Model	Popular NEMA 4X Modulating Electric (110 VAC) Model
1/2"	36.64	WE05-CHD00	WE05-CDA01	WE05-CSR02	WE05-CTD01-A	WE05-CMD01-A
3/4"	67.69	WE05-DHD00	WE05-DDA01	WE05-DSR02	WE05-DTD01-A	WE05-DMD01-A
1"	110.27	WE05-EHD00	WE05-EDA02	WE05-ESR03	WE05-ETD01-A	WE05-EMD01-A
1-1/4"	184.73	WE05-FHD00	WE05-FDA02	WE05-FSR03	WE05-FTD01-A	WE05-FMD01-A
1-1/2"	266.62	WE05-GHD00	WE05-GDA03	WE05-GSR04	WE05-GTD02-A	WE05-GMD01-A
2"	485.3	WE05-HHD00	WE05-HDA03	WE05-HSR05	WE05-HTD02-A	WE05-HMD02-A
2-1/2"	791.57	WE05-IHD00	WE05-IDA04	WE05-ISR07	WE05-ITD03-A	WE05-IMD03-A
3"	1151.95	WE05-JHD00	WE05-JDA05	WE05-JSR07	WE05-JTD03-A	WE05-JMD03-A

MODEL CHART - HAND OPERATED & PNEUMATIC ACTUATOR						
Example	WE05	-CSR02	-N	N	09	WE05-CSR02-NN09
Series	WE05					316 SS 3-piece socket weld
Size and Actuator		CHD00				1/2" hand operated
		DHD00				3/4" hand operated
		EHD00				1" hand operated
		FHD00				1-1/4" hand operated
		GHD00				1-1/2" hand operated
		HHD00				2" hand operated
		IHD00				2-1/2" hand operated
		JHD00				3" hand operated
		CDA01				1/2" double acting
		DDA01				3/4" double acting
		EDA02				1" double acting
		FDA02				1-1/4" double acting
		GDA03				1-1/2" double acting
		HDA03				2" double acting
		IDA04				2-1/2" double acting
		JDA05				3" double acting
	Solenoid		CSR02			
		DSR02				3/4" spring return
		ESR03				1" spring return
		FSR03				1-1/4" spring return
		GSR04				1-1/2" spring return
		HSR05				2" spring return
		ISR07				2-1/2" spring return
Solenoid Voltage			N			No solenoid
			A			NEMA 4X NAMUR solenoid
Positioner and Switches				N		No solenoid
				A		120 VAC
				B		220 VAC
				C		24 VAC
				D		24 VDC
				E		12 VDC
Options					00	None
					01	42AD0 exp limit switch
					02	45VD0 exp position transmitter
					03	42AD0-B ATEX limit switch
					04	42AD0-IE IECEX limit switch
					06	QV-210101 poly limit switch
					07	VPS and P1 prox switch
				08	265ER-D5 positioner	
				09	285ER-D5 smart positioner	
Options					NO	Fail open spring return actuator

ACCESSORIES	
Model	Description
AFR4	Air filter regulator 0 to 120 psi
VB-01	Volume booster

MODEL CHART - ELECTRIC ACTUATOR				
Example	WE05	-ETD01	-B	WE05-ETD01-B
Series	WE05			316 SS 3-piece socket weld
Size and Actuator		CTD01		1/2" NEMA 4X two-position
		DTD01		3/4" NEMA 4X two-position
		ETD01		1" NEMA 4X two-position
		FTD01		1-1/4" NEMA 4X two-position
		GTD02		1-1/2" NEMA 4X two-position
		HTD02		2" NEMA 4X two-position
		ITD03		2-1/2" NEMA 4X two-position
		JTD03		3" NEMA 4X two-position
		CMD01		1/2" NEMA 4X modulating
		DMD01		3/4" NEMA 4X modulating
		EMD01		1" NEMA 4X modulating
		FMD01		1-1/4" NEMA 4X modulating
		GMD01		1-1/2" NEMA 4X modulating
		HMD02		2" NEMA 4X modulating
		IMD03		2-1/2" NEMA 4X modulating
		JMD03		3" NEMA 4X modulating
	Actuator Voltage		CTI01	
		DTI01		3/4" exp two-position
		ETI02		1" exp two-position
		FTI02		1-1/4" exp two-position
		GTI03		1-1/2" exp two-position
		HTI04		2" exp two-position
		ITI05		2-1/2" exp two-position
		JTI05		3" exp two-position
		CMI01		1/2" exp electric modulating
		DMI01		3/4" exp electric modulating
		EMI02		1" exp electric modulating
		FMI02		1-1/4" exp electric modulating
		GMI03		1-1/2" exp electric modulating
		HMI04		2" exp electric modulating
		IMI05		2-1/2" exp electric modulating
	JMI05		3" exp electric modulating	
Actuator Voltage			A	110 VAC
			B	220 VAC
			C	24 VAC
			D	24 VDC

REPAIR KIT	
Model	Valve Series and Size
VRK-10	WE05-1/2"
VRK-11	WE05-3/4"
VRK-12	WE05-1"
VRK-14	WE05-1-1/2"
VRK-15	WE05-2"
VRK-16	WE05-2-1/2"
VRK-17	WE05-3"
Parts List - Included in Kit	
1 PTFE thrust washer	
1 FKM O-ring	
2 PTFE stem packing	
2 PTFE seals	
2 RTFE seats	

# 3-PIECE NPT STAINLESS STEEL V-BALL VALVES

## V-Port, Vented Ball, Electric or Pneumatic Actuators



WE06-DHD00-T



WE06-DDA01-T



WE06-DDA01-T-AA01



WE06-DTD01-T-A



WE06-CTI01-T-A



The **Series WE06 3-Piece NPT Stainless Steel V-Ball Valves** incorporate a V-port ball valve for impressive flow rates with minimal pressure drop. Quarter turn control ball valves are compact, lighter weight and much less expensive than comparable sized globe valves and segmented control valves. They also offer bubble tight shut off with zero leakage and can withstand high pressure drops. The 60° and 90° balls offer an equal percentage flow characteristic. W.E. Anderson's V-port ball valves have been designed to offer maximum flow characteristics that are substantially higher than comparably sized globe valves. The natural flow pattern of ball valves increases flow rates and in many applications valves smaller than pipeline size can be used. Limit switches can be mounted directly to the valves allowing for remote position indication.

The Series WE06 can be configured with an electric or pneumatic actuator. Electric actuators are available in weatherproof or explosion-proof, a variety of supply voltages and two-position or modulating control.

Two-position actuators use the supply voltage to drive the valve open or close, while the modulating actuator accepts a 4 to 20 mA input for valve positioning. Actuators feature thermal overload protection and a permanently lubricated gear train.

The pneumatic double acting actuator uses an air supply to drive the valve open and closed. The actuator has two supply ports with one driving the valve open and the other driving the valve closed. Spring return pneumatic actuators use the air supply to open the valve and internally loaded springs return the valve to the closed position. Also available is the SV3 solenoid valve to electrically switch the air supply pressure between the air supply ports for opening and closing the valve.

### FEATURES/BENEFITS

- The 60° and 90° balls offer an equal percentage flow characteristic
- Limit switches can be mounted to manual valves for remote monitoring
- Available with a variety of electric and pneumatic actuators

### APPLICATIONS

- Gas or liquid flow control
- Ideal for bubble tight shut off at high pressure drops

### SPECIFICATIONS

#### VALVE

**Service:** Compatible liquids and gases.

**Body:** 3-piece.

**Line Sizes:** 1/2 to 3".

**End Connections:** Female NPT.

**Pressure Limits:** 20" Hg to 1000 psi (-0.7 to 69 bar) up to 250°F.

**Wetted Materials:** Body and ball: 316 SS (CF8M); Stem: 316 SS; Seat: RTFE/PTFE; Seal, Washer, and Packing: PTFE.

**Temperature Limits:** -20 to 392°F (-29 to 200°C).

**Other Materials:** O-ring: Fluoroelastomer; Handle: 304 SS; Washer: 301 SS; Stem Nut, Locking Device, Gland Ring: 304 SS; Handle Sleeve: PVC.

**Agency Approvals:** Meets the technical requirements of EU Directive 2011/65/ EU (RoHS II).

#### ACTUATORS

##### Pneumatic "DA" and "SR" Series

**Type:** DA series is double acting and SR series is spring return (rack and pinion).

**Normal Supply Pressure:** DA: 40 to 115 psi (2.7 to 7.9 bar); SR: 80 psi (5.5 bar).

**Maximum Supply Pressure:** 120 psi (8.6 bar).

**Air Connections:** DA01: 1/8" female NPT; DA02 to DA05: 1/4" female NPT; SR02 to SR07: 1/4" female NPT.

**Housing Material:** Anodized aluminum body and epoxy coated aluminum end caps.

**Temperature Limits:** -40 to 176°F (-40 to 80°C).

**Accessory Mounting:** NAMUR standard.

##### Electric "TD" and "MD" Series

**Power Requirements:** 110 VAC, 220 VAC, 24 VAC or 24 VDC (MD models not available in 24 VDC).

**Power Consumption:** See instruction manual.

**Cycle Time (per 90°):** TD01: 4 s; MD01: 10 s; TD02 and MD02: 20 s; TD03 and MD03: 30 s.

**Duty Rating:** 85%.

**Enclosure Rating:** NEMA 4X (IP67).

**Housing Material:** Powder coated aluminum.

**Temperature Limits:** -22 to 140°F (-30 to 60°C).

**Electrical Connection:** 1/2" female NPT.

**Modulating Input:** 4-20 mA.

**Standard Features:** Manual override, position indicator, and TD models come with two limit switches.

##### Electric "TI" and "MI" Series

**Power Requirements:** 110 VAC, 220 VAC, 24 VAC or 24 VDC.

**Power Consumption:** See instruction manual.

**Cycle Time (per 90°):** See instruction manual.

**Duty Rating:** See instruction manual.

**Enclosure Rating:** NEMA 7, designed to meet hazardous locations: Class I, Group C & D; Class II, Group E, F & G; Division I & II.

**Housing Material:** Powder coated aluminum.

**Temperature Limits:** -40 to 140°F (-40 to 60°C).

**Electrical Connection:** 1/2" female NPT.

**Modulating Input:** 4-20 mA.

**Standard Features:** Position indicator and two limit switches.



# 3-PIECE NPT STAINLESS STEEL V-BALL VALVES

V-Port, Vented Ball, Electric or Pneumatic Actuators

MODEL CHART							
Size	Cv (gal/min)		Popular Hand	Popular Double Acting	Popular Spring Return	Popular NEMA 4X Two Position	Popular NEMA 4X Modulating
	60°	90°	Operated Model	Pneumatic Model	Pneumatic Model	Electric (110 VAC) Model	Electric (110 VAC) Model
1/2"	7.9	9.1	WE06-CHD00-T	WE06-CDA01-T	WE06-CSR02-T	WE06-CTD01-T-A	WE06-CMD01-T-A
3/4"	13.6	14.2	WE06-DHD00-T	WE06-DDA01-T	WE06-DSR02-T	WE06-DTD01-T-A	WE06-DMD01-T-A
1"	22.3	29.1	WE06-EHD00-T	WE06-EDA02-T	WE06-ESR03-T	WE06-ETD01-T-A	WE06-EMD01-T-A
1-1/4"	31.5	53.7	WE06-FHD00-T	WE06-FDA02-T	WE06-FSR03-T	WE06-FTD01-T-A	WE06-FMD01-T-A
1-1/2"	46.2	75.5	WE06-GHD00-T	WE06-GDA03-T	WE06-GSR04-T	WE06-GTD02-T-A	WE06-GMD01-T-A
2"	104.7	138.4	WE06-HHD00-T	WE06-HDA03-T	WE06-HSR05-T	WE06-HTD02-T-A	WE06-HMD02-T-A
2-1/2"	147.5	220.3	WE06-IHD00-T	WE06-IDA04-T	WE06-ISR07-T	WE06-ITD03-T-A	WE06-IMD03-T-A
3"	209.1	308.3	WE06-JHD00-T	WE06-JDA05-T	WE06-JSR07-T	WE06-JTD03-T-A	WE06-JMD03-T-A

MODEL CHART - HAND OPERATED & PNEUMATIC ACTUATOR								
Example	WE06	-CSR02	-T	-N	N	09	WE06-CSR02-T-NN09	
Series	WE06						316 SS 3-piece NPT	
Size and Actuator	CHD00						1/2" hand operated	
	DHD00						3/4" hand operated	
	EHD00						1" hand operated	
	FHD00						1-1/4" hand operated	
	GHD00						1-1/2" hand operated	
	HHD00						2" hand operated	
	IHD00						2-1/2" hand operated	
	JHD00						3" hand operated	
	CDA01						1/2" double acting	
	DDA01						3/4" double acting	
	EDA02						1" double acting	
	FDA02						1-1/4" double acting	
	GDA03						1-1/2" double acting	
	HDA03						2" double acting	
	IDA04						2-1/2" double acting	
	JDA05						3" double acting	
	V-Ball Angle			T				60° v-ball
			N				90° v-ball	
Solenoid					N			No solenoid
					A			NEMA 4X NAMUR solenoid
Solenoid Voltage						N		No solenoid
						A		120 VAC
						B		220 VAC
						C		24 VAC
						D		24 VDC
Positioner and Switches							00	None
						01	42AD0 exp limit switch	
						02	45VD0 exp position transmitter	
						03	42AD0-B ATEX limit switch	
						04	42AD0-IE IECEx limit switch	
Options						06	QV-210101 poly limit switch	
						07	VPS and P1 prox switch	
						08	265ER-D5 positioner	
						09	285ER-D5 smart positioner	
							NO Fail open spring return actuator	

ACCESSORIES	
Model	Description
AFR4	Air filter regulator 0 to 120 psi
VB-01	Volume booster

MODEL CHART - ELECTRIC ACTUATOR						
Example	WE06	-ETD01	-T	-B	WE06-ETD01-T-B	
Series	WE06				316 SS 3-piece NPT	
Size and Actuator	CTD01				1/2" NEMA 4X two-position	
	DTD01				3/4" NEMA 4X two-position	
	ETD01				1" NEMA 4X two-position	
	FTD01				1-1/4" NEMA 4X two-position	
	GTD02				1-1/2" NEMA 4X two-position	
	HTD02				2" NEMA 4X two-position	
	ITD03				2-1/2" NEMA 4X two-position	
	JTD03				3" NEMA 4X two-position	
	CMD01				1/2" NEMA 4X modulating	
	DMD01				3/4" NEMA 4X modulating	
	EMD01				1" NEMA 4X modulating	
	FMD01				1-1/4" NEMA 4X modulating	
	GMD01				1-1/2" NEMA 4X modulating	
	HMD02				2" NEMA 4X modulating	
	IMD03				2-1/2" NEMA 4X modulating	
	JMD03				3" NEMA 4X modulating	
	CTI01				1/2" exp two-position	
	DTI01				3/4" exp two-position	
	ETI02				1" exp two-position	
	FTI02				1-1/4" exp two-position	
GTI03				1-1/2" exp two-position		
HTI04				2" exp two-position		
ITI05				2-1/2" exp two-position		
JTI05				3" exp two-position		
V-Ball Angle			T		60° v-ball	
			N		90° v-ball	
	Actuator Voltage			A		110 VAC
				B		220 VAC
				C		24 VAC
			D		24 VDC	

REPAIR KIT	
Model	Valve Series and Size
VRK-10	WE06-1/2"
VRK-11	WE06-3/4"
VRK-12	WE06-1"
VRK-14	WE06-1-1/2"
VRK-15	WE06-2"
VRK-16	WE06-2-1/2"
VRK-17	WE06-3"
Parts List - Included in Kit	
1 PTFE thrust washer	
1 FKM O-ring	
2 PTFE stem packing	
2 PTFE seals	
2 RTFE seats	

# 2-PIECE FLANGED STAINLESS STEEL V-BALL VALVES

150# ANSI Flange, V-Ball, Electric or Pneumatic Actuators

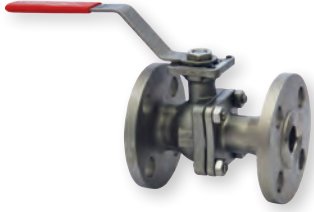

WE07-DHD00-T



WE07-DDA01-T-NN09



WE07-CTI01-T-A



WE07-DDA01-T-AA03



WE07-DTD01-T-A



The **Series WE07 2-Piece Flanged Stainless Steel V-Ball Valves** incorporate a V-port ball valve for impressive flow rates with minimal pressure drop. Quarter turn control ball valves are compact, lighter weight and much less expensive than comparable sized globe valves and segmented control valves. They also offer bubble tight shut off with zero leakage and can withstand high pressure drops. The 60° and 90° balls offer an equal percentage flow characteristic. W. E. Anderson's V-port ball valves have been designed to offer maximum flow characteristics that are substantially higher than comparably sized globe valves. The natural flow pattern of ball valves increases flow rates and in many applications valves smaller than pipeline size can be used.

The Series WE07 can be configured with an electric or pneumatic actuator. Electric actuators are available in weatherproof or explosion-proof, a variety of supply voltages and two-position or modulating control.

Two-position actuators use the supply voltage to drive the valve open or close, while the modulating actuator accepts a 4 to 20 mA input for valve positioning. Actuators feature thermal overload protection and a permanently lubricated gear train.

The pneumatic double acting actuator uses an air supply to drive the valve open and closed. The actuator has two supply ports with one driving the valve open and the other driving the valve closed. Spring return pneumatic actuators use the air supply to open the valve and internally loaded springs return the valve to the closed position. Also available is the SV3 solenoid valve to electrically switch the air supply pressure between the air supply ports for opening and closing the valve.

## FEATURES/BENEFITS

- The 60° and 90° balls offer an equal percentage flow characteristic
- Bubble tight shut off at high pressure drops
- Limit switches can be mounted to manual valves for remote monitoring
- Available with a variety of electric and pneumatic actuators

## APPLICATIONS

- Gas or liquid flow control

## SPECIFICATIONS

### VALVE

**Service:** Compatible liquids and gases.

**Body:** 2-piece.

**Line Sizes:** 1/2 to 3".

**End Connections:** 150# ANSI flange.

**Pressure Limits:** 20" Hg to 275 psi (-0.7 to 19 bar) up to 392°F.

**Wetted Materials:** Body and ball: 316 SS (CF8M); Stem: 316 SS; Seat: RTFE/PTFE; Seal, Washer, and Packing: PTFE.

**Temperature Limits:** -20 to 392°F (-29 to 200°C).

**Other Materials:** O-ring: Fluoroelastomer; Handle: 304 SS; Washer: 301 SS; Stem Nut, Locking Device, Gland Ring: 304 SS; Handle Sleeve: PVC.

**Agency Approvals:** Meets the technical requirements of EU Directive 2011/65/ EU (RoHS II).

### ACTUATORS

#### Pneumatic "DA" and "SR" Series

**Type:** DA series is double acting and SR series is spring return (rack and pinion).

**Normal Supply Pressure:** DA: 40 to 115 psi (2.7 to 7.9 bar); SR: 80 psi (5.5 bar).

**Maximum Supply Pressure:** 120 psi (8.6 bar).

**Air Connections:** DA01: 1/8" female NPT; DA02 to DA04: 1/4" female NPT; SR02 to SR06: 1/4" female NPT.

**Housing Material:** Anodized aluminum body and epoxy coated aluminum end caps.

**Temperature Limits:** -40 to 176°F (-40 to 80°C).

**Accessory Mounting:** NAMUR standard.

#### Electric "TD" and "MD" Series

**Power Requirements:** 110 VAC, 220 VAC, 24 VAC or 24 VDC (MD models not available in 24 VDC).

**Power Consumption:** See instruction manual.

**Cycle Time (per 90°):** TD01: 4 s; MD01: 10 s; TD02 and MD02: 20 s; TD03 and MD03: 30 s.

**Duty Rating:** 85%.

**Enclosure Rating:** NEMA 4X (IP67).

**Housing Material:** Powder coated aluminum.

**Temperature Limits:** -22 to 140°F (-30 to 60°C).

**Electrical Connection:** 1/2" female NPT.

**Modulating Input:** 4-20 mA.

**Standard Features:** Manual override, position indicator, and TD models come with two limit switches.

#### Electric "TI" and "MI" Series

**Power Requirements:** 110 VAC, 220 VAC, 24 VAC or 24 VDC.

**Power Consumption:** See instruction manual.

**Cycle Time (per 90°):** See instruction manual.

**Duty Rating:** See instruction manual.  
**Enclosure Rating:** NEMA 7, designed to meet hazardous locations: Class I, Group C & D; Class II, Group E, F & G; Division I & II.

**Housing Material:** Powder coated aluminum.

**Temperature Limits:** -40 to 140°F (-40 to 60°C).

**Electrical Connection:** 1/2" female NPT.

**Modulating Input:** 4-20 mA.

**Standard Features:** Position indicator and two limit switches.

# 2-PIECE FLANGED STAINLESS STEEL V-BALL VALVES

150# ANSI Flange, V-Ball, Electric or Pneumatic Actuators

MODEL CHART							
Size	Cv (gal/min)		Popular Hand Operated Model	Popular Double Acting Pneumatic Model	Popular Spring Return Pneumatic Model	Popular NEMA 4X Two Position Electric (110 VAC) Model	Popular NEMA 4X Modulating Electric (110 VAC) Model
	60°	90°					
1/2"	7.9	9.1	WE07-CHD00-T	WE07-CDA01-T	WE07-CSR02-T	WE07-CTD01-T-A	WE07-CMD01-T-A
3/4"	13.6	14.2	WE07-DHD00-T	WE07-DDA01-T	WE07-DSR02-T	WE07-DTD01-T-A	WE07-DMD01-T-A
1"	22.3	29.1	WE07-EHD00-T	WE07-EDA03-T	WE07-ESR03-T	WE07-ETD01-T-A	WE07-EMD01-T-A
1-1/2"	46.2	75.5	WE07-GHD00-T	WE07-GDA03-T	WE07-GSR04-T	WE07-GTD02-T-A	WE07-GMD01-T-A
2"	104.7	138.4	WE07-HHD00-T	WE07-HDA03-T	WE07-HSR05-T	WE07-HTD02-T-A	WE07-HMD02-T-A
2-1/2"	147.5	220.3	WE07-IHD00-T	WE07-IDA04-T	WE07-ISR06-T	WE07-ITD03-T-A	WE07-IMD03-T-A
3"	209.1	308.3	WE07-JHD00-T	WE07-JDA04-T	WE07-JSR06-T	WE07-JTD03-T-A	WE07-JMD03-T-A

MODEL CHART - HAND OPERATED & PNEUMATIC ACTUATOR							
Example	WE07	-CSR02	-T	-N	N	09	WE07-CSR02-T-NN09
Series	WE07						316 SS 2-piece 150# ANSI flange
Size and Actuator		CHD00 DHD00 EHD00 GHD00 HHD00 IHD00 JHD00 CDA01 DDA01 EDA03 GDA03 HDA03 IDA04 JDA04 CSR02 DSR02 ESR03 GSR04 HSR05 ISR06 JSR06					1/2" hand operated 3/4" hand operated 1" hand operated 1-1/2" hand operated 2" hand operated 2-1/2" hand operated 3" hand operated 1/2" double acting 3/4" double acting 1" double acting 1-1/2" double acting 2" double acting 2-1/2" double acting 3" double acting 1/2" spring return 3/4" spring return 1" spring return 1-1/2" spring return 2" spring return 2-1/2" spring return 3" spring return
V-Ball Angle			T N				60° v-ball 90° v-ball
Solenoid				N A			No solenoid NEMA 4X NAMUR solenoid
Solenoid Voltage					N A B C D E		No solenoid 120 VAC 220 VAC 24 VAC 24 VDC 12 VDC
Positioner and Switches						00 01 02 03 04 06 07 08 09	None 42AD0 exp limit switch 45VD0 exp position transmitter 42AD0-B ATEX limit switch 42AD0-IE IECEX limit switch QV-210101 poly limit switch VPS and P1 prox switch 265ER-D5 positioner 285ER-D5 smart positioner
Options						NO	Fail open spring return actuator

ACCESSORIES	
Model	Description
AFR4	Air filter regulator 0 to 120 psi
VB-01	Volume booster

MODEL CHART - ELECTRIC ACTUATOR					
Example	WE07	-ETD01	-T	-B	WE07-ETD01-T-B
Series	WE07				316 SS 2-piece 150# ANSI flange
Size and Actuator		CTD01 DTD01 ETD01 GTD02 HTD02 ITD03 JTD03 CMD01 DMD01 EMD01 GMD01 HMD02 IMD03 JMD03 CTI01 DTI01 ETI02 GTI03 HTI04 ITI04 JTI05 CMI01 DMI01 EMI02 GMI03 HMI04 IMI04 JMI05			1/2" NEMA 4X two-position 3/4" NEMA 4X two-position 1" NEMA 4X two-position 1-1/2" NEMA 4X two-position 2" NEMA 4X two-position 2-1/2" NEMA 4X two-position 3" NEMA 4X two-position 1/2" NEMA 4X modulating 3/4" NEMA 4X modulating 1" NEMA 4X modulating 1-1/2" NEMA 4X modulating 2" NEMA 4X modulating 2-1/2" NEMA 4X modulating 3" NEMA 4X modulating 1/2" exp two-position 3/4" exp two-position 1" exp two-position 1-1/2" exp two-position 2" exp two-position 2-1/2" exp two-position 3" exp two-position 1/2" exp electric modulating 3/4" exp electric modulating 1" exp electric modulating 1-1/2" exp electric modulating 2" exp electric modulating 2-1/2" exp electric modulating 3" exp electric modulating
V-Ball Angle			T N		60° v-ball 90° v-ball
Actuator Voltage				A B C D	110 VAC 220 VAC 24 VAC 24 VDC

REPAIR KIT	
Model	Valve Series and Size
VRK-27	WE07-1/2"
VRK-28	WE07-3/4"
VRK-29	WE07-1"
VRK-31	WE07-1-1/2"
VRK-32	WE07-2"
VRK-33	WE07-2-1/2"
VRK-34	WE07-3"
Parts List - Included in Kit	
1 PTFE thrust washer	
1 FKM O-ring	
2 PTFE stem packing	
2 PTFE seals	
2 RTFE seats	



SERIES PBV | W.E. ANDERSON™ BY DWYER

# PLASTIC AUTOMATED BALL VALVES

Electric and Pneumatic Actuators



PVC body



CPVC body

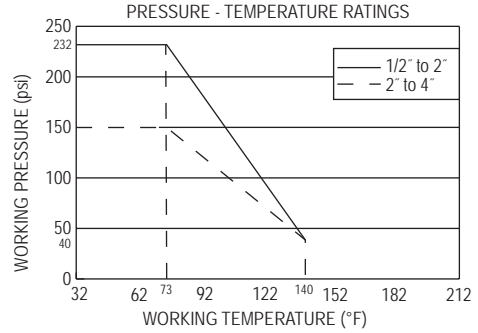

The **Series PBV Plastic Automated Ball Valves** are ideal for services in industrial, chemical, turf and irrigation, and pool and spa applications, as well as for use with potable water. The valve features a shear-proof stem designed to prevent leakage in the event of damage, reinforced TFE seats and EPDM seals for longer life, and an all-plastic construction (PVC or CPVC) for heavyweight durability at a lightweight cost. Valves also come standard with selectable NPT or socket process connections.

The PBV is an economical automated valve package with either an electric or pneumatic actuator. Electrically actuated models are weatherproof, NEMA 4 (IP56), powered by standard 115 VAC supply, and are available in either two-position or proportional control. Two-position actuators use the 115 VAC input to drive each of the valve ports open or closed, while the modulating actuator accepts a 4 to 20 mA input for infinite valve positioning. Actuator features include thermal overload protection to withstand stall conditions, visual position indication and a permanently lubricated gear train.

The pneumatic double acting actuator uses an air supply to drive each of the actuator ports. Spring return pneumatic actuators use the air supply to drive the valve stem one direction, and internally loaded springs return the valve to its original position. Also available is the SV3 solenoid valve to electrically switch the supply pressure between the air supply ports. Actuators are constructed of anodized aluminum and are epoxy coated for years of corrosion free service.

**FEATURES/BENEFITS**

- Shear proof stem
- All plastic construction

**APPLICATIONS**

- Gas or liquid flow control

OPTIONS		
To order add suffix:	Description	Actuator Size*
-EX	Explosion proof electric actuators	XX1-XX6

\*Example: Third digit in U12 or V12 is the size.

Note: For optional electric actuator supply voltages, contact factory for model number change.

MODEL CHART - PVC					
Size	CV	Double Acting Pneumatic	Spring Return Pneumatic	Two Position Electric	Modulating Electric
		Model	Model	Model	Model
1/2"	25	PBVPDA102	PBVPSR202	PBVPU1102	PBVPV1202
3/4"	51	PBVPDA103	PBVPSR203	PBVPU1103	PBVPV1203
1"	97	PBVPDA104	PBVPSR204	PBVPU1104	PBVPV1204
1-1/4"	204	PBVPDA105	PBVPSR205	PBVPU1105	PBVPV1205
1-1/2"	285	PBVPDA206	PBVPSR306	PBVPU1106	PBVPV1206
2"	540	PBVPDA207	PBVPSR307	PBVPU1207	PBVPV1207
2-1/2"	712	PBVPDA308	PBVPSR608	PBVPU1308	PBVPV1308
3"	1294	PBVPDA309	PBVPSR609	PBVPU1509	PBVPV1509
4"	2629	PBVPDA410	PBVPSR710	PBVPU1510	PBVPV1510

Note: All spring return actuators are factory standard as spring (fail) close. For spring (fail) open valves, add suffix "-FO" to the model number.

MODEL CHART - CPVC					
Size	CV	Double Acting Pneumatic	Spring Return Pneumatic	Two Position Electric	Modulating Electric
		Model	Model	Model	Model
1/2"	25	PBVCDA102	PBVCSR202	PBVPU1102	PBVCV1202
3/4"	51	PBVCDA103	PBVCSR203	PBVPU1103	PBVCV1203
1"	97	PBVCDA104	PBVCSR204	PBVPU1104	PBVCV1204
1-1/4"	204	PBVCDA105	PBVCSR205	PBVPU1105	PBVCV1205
1-1/2"	285	PBVCDA206	PBVCSR306	PBVPU1106	PBVCV1206
2"	540	PBVCDA207	PBVCSR307	PBVPU1207	PBVCV1207
2-1/2"	712	PBVCDA308	PBVCSR608	PBVPU1308	PBVCV1308
3"	1294	PBVCDA309	PBVCSR609	PBVPU1509	PBVCV1509
4"	2629	PBVCDA410	PBVCSR710	PBVPU1510	PBVCV1510

Note: All spring return actuators are factory standard as spring (fail) close. For spring (fail) open valves, add suffix "-FO" to the model number.

**SPECIFICATIONS**

**Service:** Compatible liquids or gases.  
**Body:** 2-way.  
**Line Size:** 1/2" to 4".  
**End Connections:** Female NPT or socket (field selectable).  
**Pressure Limit:** 1/2" to 2": 232 psi (16.0 bar) @ 73°F (23°C); 2-1/2" to 4": 150 psi (10.3 bar) @ 73°F (23°C) WOG. Vacuum: 29" Hg.  
**Wetted Materials:** Body, end connectors: PVC or CPVC; Ball, stem: PVC or CPVC; Seat: TFE; Stem seal: EPDM.  
**Temperature Limit:** 32 to 140°F (0 to 60°C).  
**Other Materials:** Stem bearing: Polypropylene (1-1/4" and up).

**Housing Material:** Aluminum with thermal bonding polyester powder finish.  
**Temperature Limit:** 0 to 150°F (-18 to 65°C).  
**Conduit Connection:** 1/2" female NPT.  
**Modulating Input:** 4-20 mA.  
**Standard Features:** Manual override and visual position indicator except modulating units.

**Pneumatic "DA" and "SR" Series**  
**Type:** DA series is double acting and SR series is spring return (rack and pinion).  
**Normal Supply Pressure:** 80 psi (5.5 bar).  
**Maximum Supply Pressure:** 120 psig (8 bar).  
**Air Connections:** DA/SR1 to 5: 1/8" female NPT, all other sizes: 1/4" female NPT.  
**Air Consumption:** (per stroke) DA1: 2.32 in3; DA2: 9.34 in3; DA3: 17.21 in3; DA4: 20.5 in3; SR2: 9.34 in3; SR3: 17.21 in3; SR6: 54.34 in3; SR7: 85.43 in3.  
**Cycle Time:** (per 90°) DA1: .03 s; DA2: .04 s; DA3: .08 s; DA4: .12 s; SR2: .09 s; SR3: .14 s; SR6: .46 s; SR7: .83 s.  
**Housing Material:** Anodized aluminum body and epoxy coated aluminum end caps.  
**Temperature Limit:** -4 to 180°F (-20 to 82°C).  
**Accessory Mounting:** NAMUR standard.  
**Standard Features:** Visual position indicator.

**ACTUATORS**

**Electric**  
**Power Requirements:** 120 VAC, 50/60 Hz, single phase. Optional 220 VAC, 24 VAC, 12 VDC, and 24 VDC.  
**Power Consumption:** (Locked rotor current): Two position: 1/2" to 1-1/2": .55 A, 2" to 4": 0.75 A. Modulating: 1/2" to 2": 0.75 A, 2-1/2": 1.1 A, 3" and 4": 0.75 A.  
**Cycle Time:** (per 90°): Two position: 1/2" to 1-1/2": 2.5 s, 2" and 2-1/2": 5 s, 3" and 4": 15 s; Modulating: 1/2" to 2-1/2": 5 s, 3" and 4": 15 s.  
**Duty Cycle:** Two position: 1/2" to 1-1/2": 75%, 2" to 4": 25%. Modulating: 75%.  
**Enclosure Rating:** NEMA 4. Optional NEMA 7 (Class 1, Div. II groups A, B, C, D).

Filters and Regulators: See pages 447-448



# BRASS BALL VALVE

Full Port, Economical, 600 psi (41 bar)

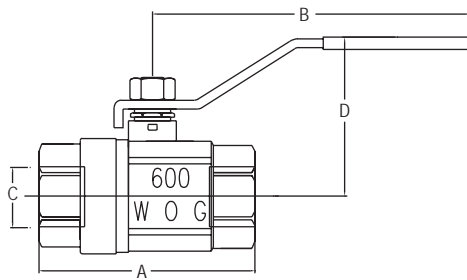

NPT Size	A in [mm]	B in [mm]	C in [mm]	D in [mm]
1/4"	1-39/64 [40.89]	3-5/32 [80.01]	5/16 [7.87]	1-47/64 [43.94]
3/8"	1-45/64 [43.18]	3-5/32 [80.01]	25/64 [9.91]	1-13/16 [45.97]
1/2"	2-3/16 [55.63]	3-55/64 [98.04]	19/32 [15.24]	2-11/64 [55.12]
3/4"	2-23/64 [59.94]	3-55/64 [98.04]	3/4 [19.05]	2-9/32 [57.91]
1"	2-7/8 [72.90]	4-13/32 [112.01]	63/64 [24.89]	2-11/16 [68.07]
1-1/4"	3-5/16 [84.07]	4-51/64 [121.92]	1-17/64 [32.00]	3-5/32 [80.01]
1-1/2"	3-47/64 [95.00]	5-7/16 [137.92]	1-9/16 [39.88]	3-55/64 [98.04]
2"	4-13/32 [112.01]	5-7/16 [137.92]	1-31/32 [50.04]	4-13/64 [106.93]
2-1/2"	5-53/64 [148.08]	8-1/2 [215.90]	2-31/64 [62.99]	4-61/64 [125.98]
3"	6-29/64 [163.83]	8-1/2 [215.90]	2-61/64 [74.93]	5-1/8 [130.05]

The **Series DBV Brass Ball Valve** is an economical hand lever ball valve ideal for commercial or general industrial use. The Series DBV is the ideal choice for a manual shut off valve, along with many other applications. Valve body, body cap and ball are made of a quality brass for great durability. Seats and stem packing are constructed of PTFE for long lasting service as well. Blowout-proof stem provides safety in the event of overpressure. Full port design allows for maximum Cv while still retaining minimal pressure drop.

**FEATURES/BENEFITS**

- Low cost
- Blowout-proof stem

**APPLICATIONS**

- Gas or liquid flow control

**SPECIFICATIONS**

**Service:** Gases and liquids compatible with wetted materials.  
**End Connections:** 1/4 to 3" female NPT.  
**Pressure Limits:** -29" Hg to 600 psi (-736 mm Hg to 41 bar) WOG.  
**Temperature limit:** -40 to 365°F (-40 to 185°C).  
**Wetted Materials:** Body and body cap: Brass; Ball: Chrome plated brass; Stem: Brass; Seat and packing: PTFE.  
**Other Materials:** Body gland and stem nut: Brass; Handle cover: Rubber; Handle: steel.

**MODEL CHART**

Model	Pipe Size	Model	Pipe Size
DBV-00	1/4"	DBV-05	1-1/4"
DBV-01	3/8"	DBV-06	1-1/2"
DBV-02	1/2"	DBV-07	2"
DBV-03	3/4"	DBV-08	2-1/2"
DBV-04	1"	DBV-09	3"

USA: California Proposition 65  
 ⚠ WARNING: Cancer and Reproductive Harm - www.P65Warnings.ca.gov

SERIES BV2M | W.E. ANDERSON™ BY DWYER

# TWO-PIECE STAINLESS STEEL BALL VALVE

Full Port, 1000 psig (69 bar)

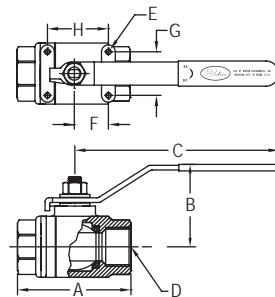

DIMENSIONS (IN)							
A (Ref)	B (Ref)	C (Ref)	D (NPT)	E (UNC)	F (+.015)	G (+.015)	H (+.015)
1/4"	2.165	4.055	1/4"	(2) 3/16-24	0.500	1.102	N/A
3/8"	2.165	4.055	3/8"	(2) 3/16-24	0.500	1.102	N/A
1/2"	2.559	5.236	1/2"	(2) 3/16-24	0.500	1.102	N/A
3/4"	2.992	5.236	3/4"	(2) 3/16-24	0.882	1.378	N/A
1"	3.465	6.024	1"	(2) 3/16-24	0.882	1.378	N/A
1-1/4"	3.976	6.024	1-1/4"	(2) 1/4-20	1.000	1.500	N/A
1-1/2"	4.331	7.520	1-1/2"	(2) 1/4-20	1.000	1.500	N/A
2"	4.882	7.520	2"	(4) 1/4-20	1.000	1.500	2.000
2-1/2"	6.299	9.724	2-1/2"	(4) 1/4-20	1.382	2.165	2.764
3"	6.929	9.724	3"	(4) 1/4-20	1.382	2.165	2.764

The **Series BV2M Two-Piece Stainless Steel Ball Valve** is the economical choice for high quality, SS ball valves for use in chemical, petrochemical, pulp and paper and general applications. The Series BV2M body and endcaps are constructed of investment cast SS, while stem is 316 SS. Seats and body seals are 15% glass reinforced PTFE providing broad media compatibility and bubble tight shutoff to 1000 psig (69 bar). Internally loaded, blowout-proof stem provides safety in the event of overpressure. Full port design allows for maximum Cv with minimal pressure drop. Integral actuator mounting pads allows for ease of automation.

**FEATURES/BENEFITS**

- Wide chemical compatibility
- Bubble tight shut off to 1000 psig
- Blowout-proof stem
- Actuator mounting pad

**APPLICATIONS**

- Gas or liquid flow control
- Chemical, petrochemical, pulp and paper, and other general applications

**SPECIFICATIONS**

**End Connections:** Female NPT.  
**Pressure Limits:** 1000 psi (69 bar) WOG, 150 psi (10.3 bar) SWP.  
**Wetted Materials:** Body, ball, end cap: CF8M SS; Stem: 316 SS; Seat, thrust washer: RTFE; End gasket, stem packing: PTFE.  
**Temperature Limits:** -20 to 450°F (-29 to 232°C).  
**Agency Approvals:** Meets the technical requirements of EU Directive 2011/65/EU (RoHS II).

**MODEL CHART**

Model	Size	Model	Size
BV2M100	1/4"	BV2M105	1-1/4"
BV2M101	3/8"	BV2M106	1-1/2"
BV2M102	1/2"	BV2M107	2"
BV2M103	3/4"	BV2M108	2-1/2"
BV2M104	1"	BV2M109	3"



SERIES DBVL & SWBV | W.E. ANDERSON™ BY DWYER



# LOW LEAD NPT BRASS BALL VALVES

Economical, Easy to Install

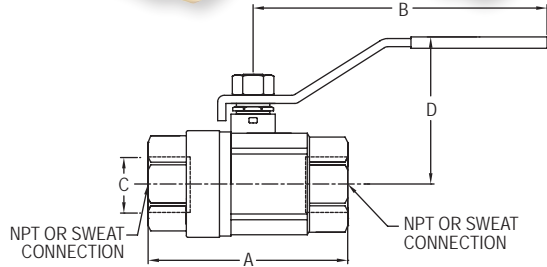

DBVL DIMENSIONS				
NPT Size	A in [mm]	B in [mm]	C in [mm]	D in [mm]
1/4"	1-3/4 [44.6]	3-5/32 [80]	25/64 [10]	1-47/64 [44.2]
3/8"	1-3/4 [44.6]	3-5/32 [80]	25/64 [10]	1-47/64 [44.2]
1/2"	2-3/64 [52]	4-1/64 [102]	19/32 [15]	1-7/8 [47.5]
3/4"	2-23/64 [60]	4-1/64 [102]	3/4 [19]	2-1/64 [51]
1"	2-3/4 [70]	4-17/32 [115]	63/64 [25]	2-23/32 [69]
1-1/4"	3-5/16 [84]	5 [127]	1-17/64 [32]	3-1/32 [77]
1-1/2"	3-21/32 [93]	5-19/32 [142]	1-37/64 [40]	3-1/32 [94]
2"	4-3/16 [106.2]	5-19/32 [142]	1-31/32 [50]	4 [101]
2-1/2"	5-3/8 [136.6]	8-21/32 [220]	2-33/64 [64]	1-49/64 [121]
3"	6-1/32 [153.4]	8-21/32 [220]	2-29/32 [74]	5-5/64 [129]

SWBV DIMENSIONS				
Sweat Size	A in [mm]	B in [mm]	C in [mm]	D in [mm]
1/4"	1-55/64 [47.24]	3-5/32 [80.01]	23/64 [9.14]	1-47/64 [43.94]
3/8"	1-55/64 [47.24]	3-5/32 [80.01]	1/2 [12.70]	1-47/64 [43.94]
1/2"	2-15/64 [56.90]	3-55/64 [98.04]	5/8 [15.75]	2-15/64 [56.90]
3/4"	2-51/64 [70.87]	3-55/64 [98.04]	7/8 [22.35]	2-23/64 [59.94]
1"	3-35/64 [89.92]	4-13/32 [112.01]	1-1/8 [28.70]	2-45/64 [68.58]
1-1/4"	4-1/8 [104.90]	4-51/64 [121.92]	1-3/8 [35.05]	3-3/64 [77.22]
1-1/2"	4-11/16 [119.13]	5-7/16 [137.92]	1-5/8 [41.40]	3-51/64 [96.27]
2"	5-35/64 [140.97]	5-7/16 [137.92]	2-1/8 [54.10]	4-5/32 [105.41]
2-1/2"	6-39/64 [167.89]	8-3/16 [207.77]	2-41/64 [67.06]	4-63/64 [126.49]
3"	6-57/64 [175.01]	9-11/16 [245.87]	3-13/32 [86.61]	5-1/16 [128.52]

The Series DBVL & SWBV Low Lead NPT Brass Ball Valves are economical hand lever ball valves ideal for commercial or industrial use where lead content is regulated. The valve body, body cap, and stem are made of a quality low lead brass for great durability and compatibility. The seats and stem packing are constructed of PTFE for long lasting service. A blowout-proof stem provides safety in the event of overpressure, and the full port design allows for the maximum flow coefficient while still retaining minimal pressure drop.

**FEATURES/BENEFITS**

- Low lead brass
- PTFE seats to stem
- Blowout-proof stem

**APPLICATIONS**

- Gas or liquid flow control

**MODEL CHART**

Model	Pipe Size (in)	Model	Pipe Size (in)
DBVL-00	1/4	SWBV-00	1/4
DBVL-01	3/8	SWBV-01	3/8
DBVL-02	1/2	SWBV-02	1/2
DBVL-03	3/4	SWBV-03	3/4
DBVL-04	1	SWBV-04	1
DBVL-05	1-1/4	SWBV-05	1-1/4
DBVL-06	1-1/2	SWBV-06	1-1/2
DBVL-07	2	SWBV-07	2
DBVL-08	2-1/2	SWBV-08	2-1/2
DBVL-09	3	SWBV-09	3

**SPECIFICATIONS**

**Service:** Gases and liquids compatible with wetted materials.  
**End Connections:** DBVL: 1/4" to 3" female NPT; SWBV: 1/4" to 3" sweat connections.  
**Pressure Limits:** 1/4" to 2": -29" Hg to 600 psi (-736 mm Hg to 41 bar) WOG; DBVL: 2-1/2" to 3": -29" Hg to 250 psi (-736 mm Hg to 17 bar) WOG; SWBV: 2-1/2" to 3": -29" Hg to 400 psi (-736 mm Hg to 27 psi) WOG.  
**Temperature Limits:** -40° to 365°F (-40° to 185°C).  
**Wetted Materials:** Body, Body Cap, and Stem: Brass; Seat and Packing: PTFE; Ball: DBVL: 1/4" to 1": Chrome Plated Brass; 1-1/4" to 3": Stainless Steel; SWBV: Stainless Steel.  
**Other Materials:** Body Gland and Stem Nut: Brass; Handle and Handle Nut: Steel; Handle Cover: Rubber.  
**Agency Approvals:** Meets the technical requirements of EU Directive 2011/65/EU (RoHS II).

USA: California Proposition 65  
 ⚠ WARNING: Cancer and Reproductive Harm - www.P65Warnings.ca.gov

SERIES UBV | W.E. ANDERSON™ BY DWYER

# UNI-FLANGED BALL VALVE

Forged Brass Construction, Economical, 600 psi (41 bar)

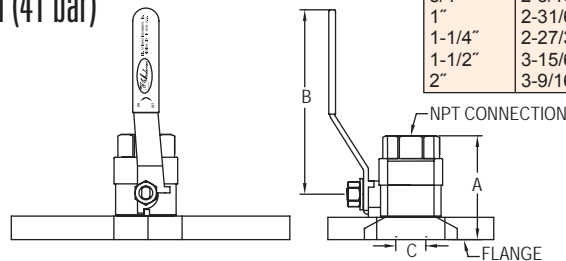

NPT Size	A in [mm]	B in [mm]	C in [mm]
1/2"	1-63/43 [50.29]	2-7/8 [72.90]	35/64 [13.97]
3/4"	2-3/16 [55.37]	2-7/8 [72.90]	49/64 [19.30]
1"	2-31/64 [62.99]	2-7/8 [72.90]	61/64 [24.38]
1-1/4"	2-27/32 [72.14]	4 [101.60]	1-31/64 [29.97]
1-1/2"	3-15/64 [82.04]	4-5/32 [105.41]	1-31/64 [37.85]
2"	3-9/16 [90.42]	4-5/32 [105.41]	1-37/32 [46.99]

The Series UBV Uni-Flanged Ball Valve is an economical yet durable ball valve great for residential or industrial use. The forged brass body provides the strength and versatility needed for any application. The ball valve is constructed of quality brass in conjunction with PTFE ball seats to work with up to 600 psi (41 bar) of working pressure. Full port construction helps to reduce flow resistance while still maintaining great durability with its one-body construction. Available in a wide variety of sizes for versatile application.

**FEATURES/BENEFITS**

- Economical
- Unibody construction
- PTFE ball seats

**APPLICATIONS**

- Gas or liquid flow control

**SPECIFICATIONS**

**Service:** Gases and liquids compatible with wetted materials.  
**End Connections:** Female NPT.  
**Pressure Limits:** -29" Hg to 600 psi (-736 mm Hg to 41.3 bar).  
**Temperature Limit:** -40 to 365°F (-40 to 185°C).  
**Wetted Materials:** Body and cap: Brass; Ball: Chrome plated brass; Stem: Brass; Stem packing and ball seat: PTFE.  
**Other Materials:** Gland and stem nut: Brass; Handle: Steel; Grip: Rubber.

**MODEL CHART**

Model	Pipe Size	Model	Pipe Size	Model	Pipe Size
UBV-00	1/2"	UBV-02	1"	UBV-04	1-1/2"
UBV-01	3/4"	UBV-03	1-1/4"	UBV-05	2"

USA: California Proposition 65  
 ⚠ WARNING: Cancer and Reproductive Harm - www.P65Warnings.ca.gov

# MINI BRASS BALL VALVES

Economical, Compact Design



Lever handle



Screwdriver slot



Tee handle



Wedge handle

Series MV Mini Brass Ball Valves are ideal for use in small, confined spaces, where larger valves are of no use. Installation is made easy with a choice of FxF or MxF process connections. Pure PTFE ball seats provide broad media compatibility and bubble tight shutoff. Double seal system allows valve to be operated in both directions.

**FEATURES/BENEFITS**

- Bubble tight shutoff
- Economical
- Valve can be operated in both directions

**APPLICATIONS**

- Gas or liquid flow control
- Ideal for small, confined spaces

**SPECIFICATIONS**

**Service:** Gases and liquid compatible with wetted materials. Not rated for steam use.

**End Connections:** NPT, see model chart.

**Pressure Limits:** -29" Hg to 450 psi (-736 mm Hg to 31 bar).

**Temperature Limits:** -4 to 250°F (-20 to 121°C).

**Wetted Materials:** Valve Body: Chrome-plated brass; Valve Ball: Chrome-plated brass; O-ring Stem Seal: Fluoroelastomer; Ball Seats: PTFE.

Female x Female			Male x Female		
Model	Handle Style	Pipe Size	Model	Handle Style	Pipe Size
MVB-LF1	Lever handle	1/8"	MVB-LM1	Lever handle	1/8"
MVB-LF2	Lever handle	1/4"	MVB-LM2	Lever handle	1/4"
MVB-LF3	Lever handle	3/8"	MVB-LM3	Lever handle	3/8"
MVB-LF4	Lever handle	1/2"	MVB-LM4	Lever handle	1/2"
MVB-TF1	Tee handle	1/8"	MVB-TM1	Tee handle	1/8"
MVB-TF2	Tee handle	1/4"	MVB-TM2	Tee handle	1/4"
MVB-TF3	Tee handle	3/8"	MVB-TM3	Tee handle	3/8"
MVB-TF4	Tee handle	1/2"	MVB-TM4	Tee handle	1/2"
MVB-WF1	Wedge handle	1/8"	MVB-WM1	Wedge handle	1/8"
MVB-WF2	Wedge handle	1/4"	MVB-WM2	Wedge handle	1/4"
MVB-WF3	Wedge handle	3/8"	MVB-WM3	Wedge handle	3/8"
MVB-WF4	Wedge handle	1/2"	MVB-WM4	Wedge handle	1/2"
MV5-SF1	Screwdriver slot	1/8"	MV5-SM1	Screwdriver slot	1/8"
MV5-SF2	Screwdriver slot	1/4"	MV5-SM2	Screwdriver slot	1/4"
MV5-SF3	Screwdriver slot	3/8"	MV5-SM3	Screwdriver slot	3/8"
MV5-SF4	Screwdriver slot	1/2"	MV5-SM4	Screwdriver slot	1/2"

USA: California Proposition 65

⚠ WARNING: Cancer and Reproductive Harm - www.P65Warnings.ca.gov

SERIES SMV2 | W.E. ANDERSON™ BY DWYER

# MINI STAINLESS STEEL BALL VALVE

Economical, Wide Chemical Compatibility, Compact

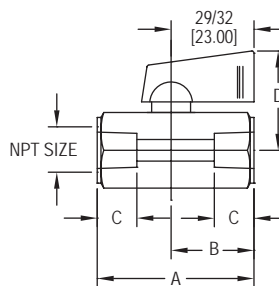

Female X female connection  
SMV2-WFX

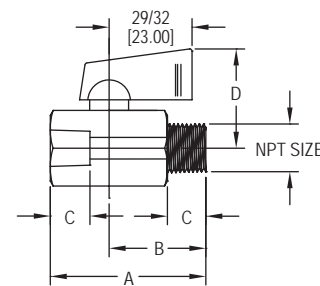

Male X female connection  
SMV2-WMX

The Series SMV2 Mini Stainless Steel Ball Valve is ideal for small, confined spaces, where larger valves are unsuitable. The 316 SS and PTFE wetted materials are excellent for applications with corrosive media. The handles are made of a rigid nylon for extended durability. Installation is made easy with a choice of FxF or MxF process connections. PTFE ball seats provide broad media compatibility and bubble tight shutoff.

**FEATURES/BENEFITS**

- High working pressure
- Abrasion resistant
- Easy to install
- Economical
- Wide chemical compatibility

**APPLICATIONS**

- Gas or liquid flow control
- Ideal for small, confined spaces

**SPECIFICATIONS**

**Service:** Gases and liquids compatible with wetted materials. Not rated for steam use.

**End Connections:** NPT, see model chart.

**Pressure Limits:** 1/8" to 3/8", 1000 psi (68.9 bar) WOG; 1/2", 800 psi (51.1 bar) WOG.

**Temperature Limits:** 212°F (100°C) maximum.

**Wetted Materials:** Valve Body: Cast 316 SS (CF8M); Valve Ball, Insert and Stem: 316 SS; Ball Seat: PTFE.

**Agency Approvals:** Meets the technical requirements of EU Directive 2011/65/EU (RoHS II).

MODEL CHART		
Pipe Size	Female x Female Model	Male x Female Model
1/8"	SMV2-WF1	SMV2-WM1
1/4"	SMV2-WF2	SMV2-WM2
3/8"	SMV2-WF3	SMV2-WM3
1/2"	SMV2-WF4	SMV2-WM4

# 3-WAY NPT STAINLESS STEEL BALL VALVES

Full Port, Vented Ball, Electric or Pneumatic Actuators



WE31-DHD00-T1



WE31-DDA02-L1



WE31-DDA02-T1-AA01



WE31-DDA02-T3-NN05



WE31-DTD01-T3-A



The **Series WE31 3-Way NPT Stainless Steel Ball Valves** incorporate a full port valve for great flow rates with minimal pressure drop. The valve features a blowout-proof stem for added safety, reinforced PTFE seats and seals for longer life, and a 316 SS (ASTM CF8M) ball for better performance. Actuators are direct mounted creating a compact assembly for tight spaces. Limit switches are able to be mounted directly to the valves allowing for remote position indication.

The Series WE31 can be configured with either an electric or pneumatic actuator. Electric actuators are available in weatherproof or explosion-proof, a variety of supply voltages and two-position or modulating control. Two-position actuators use the supply voltage to drive the valve open or closed, while the modulating actuator accepts a 4 to 20 mA input for valve positioning. Actuators feature thermal overload protection and permanently lubricated gear train.

The pneumatic double acting actuator uses an air supply to drive the valve open and closed. The actuator has two supply ports, with one driving the valve open and the other driving the valve closed. Spring return pneumatic actuators use the air supply to open the valve, and internally loaded springs return the valve to the closed position. Also available is the SN solenoid valve to electrically switch the air supply pressure between the air supply ports for opening and closing the valve. Actuators are constructed of anodized and epoxy coated aluminum for years of corrosion free service.

## FEATURES/BENEFITS

- Capable of being configured to fit any application
- Limit switches can be mounted to manual valves for remote monitoring
- Vented ball to reduce operating torque
- Weatherproof or explosion-proof electric actuators
- Double acting or spring return anodized aluminum pneumatic actuators
- Full port design reduces the pressure drop across the valve

## APPLICATIONS

- Gas or liquid flow control
- Ideal for quick bubble tight shut-off
- Mixing or diverting liquids and gases

## SPECIFICATIONS

### VALVE

**Service:** Compatible liquids and gases.

**Body:** 3-way.

**Line Sizes:** 1/2 to 2".

**End Connections:** Female NPT.

**Pressure Limits:** 28" Hg to 1000 psi (-0.7 to 69 bar) up to 250°F.

**Wetted Materials:** Body and ball: 316 SS (CF8M); Stem: 316 SS; Seat: RTFE/PTFE; Seal, Washer, and Packing: PTFE.

**Temperature Limits:** -20 to 392°F (-29 to 200°C).

**Other Materials:** O-ring:

Fluoroelastomer; Handle: 304 SS; Washer: 301 SS; Stem Nut, Locking Device, Gland Ring: 304 SS; Handle Sleeve: PVC.

**Agency Approvals:** Meets the technical requirements of EU Directive 2011/65/EU (RoHS II).

### ACTUATORS

**Pneumatic "DA" and "SR" Series**

**Type:** DA series is double acting and SR series is spring return (rack and pinion).

**Normal Supply Pressure:** DA: 40 to 115 psi (2.7 to 7.9 bar); SR: 80 psi (5.5 bar).

**Maximum Supply Pressure:** 120 psi (8.6 bar).

**Air Connections:** DA01: 1/8" female NPT; DA02 to DA04: 1/4" female NPT; SR03 to SR07: 1/4" female NPT.

**Housing Material:** Anodized aluminum body and epoxy coated aluminum end caps.

**Temperature Limits:** -40 to 176°F (-40 to 80°C).

**Accessory Mounting:** NAMUR standard.

**Electric "TD" and "MD" Series**

**Power Requirements:** 110 VAC, 220 VAC, 24 VAC or 24 VDC

(MD models not available in 24 VDC).

**Power Consumption:** See instruction manual.

**Cycle Time (per 90°):** TD01: 4 s; MD01: 10 s; TD02 and MD02: 20 s; TD03 and MD03: 30 s.

**Duty Rating:** 85%.

**Enclosure Rating:** NEMA 4X (IP67).

**Housing Material:** Powder coated aluminum.

**Temperature Limits:** -22 to 140°F (-30 to 60°C).

**Electrical Connection:** 1/2" female NPT.

**Modulating Input:** 4-20 mA.

**Standard Features:** Manual override, position indicator, and TD models come with two limit switches.

**Electric "TI" and "MI" Series**

**Power Requirements:** 110 VAC, 220 VAC, 24 VAC or 24 VDC.

**Power Consumption:** See instruction manual.

**Cycle Time (per 90°):** See instruction manual.

**Duty Rating:** See instruction manual.

**Enclosure Rating:** NEMA 7, designed to meet hazardous locations: Class I, Group C & D; Class II, Group E, F & G; Division I & II.

**Housing Material:** Powder coated aluminum.

**Temperature Limits:** -40 to 140°F (-40 to 60°C).

**Electrical Connection:** 1/2" female NPT.

**Modulating Input:** 4-20 mA.

**Standard Features:** Position indicator and two limit switches.



# 3-WAY NPT STAINLESS STEEL BALL VALVES

Full Port, Vented Ball, Electric or Pneumatic Actuators

MODEL CHART						
Size	Cv (gal/min)	Popular Hand Operated Model	Popular Double Acting Pneumatic Model	Popular Spring Return Pneumatic Model	Popular NEMA 4X Two Position Electric (110 VAC) Model	Popular NEMA 4X Modulating Electric (110 VAC) Model
1/2"	11	WE31-CHD00-T1	WE31-CDA02-T2	WE31-CSR02-T2	WE31-CTD01-T2-A	WE31-CMD01-T2-A
3/4"	14	WE31-DHD00-T1	WE31-DDA02-T2	WE31-DSR03-T2	WE31-DTD01-T2-A	WE31-DMD01-T2-A
1"	18	WE31-EHD00-T1	WE31-EDA03-T2	WE31-ESR04-T2	WE31-ETD02-T2-A	WE31-EMD02-T2-A
1-1/4"	43	WE31-FHD00-T1	WE31-FDA03-T2	WE31-FSR05-T2	WE31-FTD02-T2-A	WE31-FMD02-T2-A
1-1/2"	84	WE31-GHD00-T1	WE31-GDA04-T2	WE31-GSR06-T2	WE31-GTD03-T2-A	WE31-GMD03-T2-A
2"	90	WE31-HHD00-T1	WE31-HDA04-T2	WE31-HSR07-T2	WE31-HTD03-T2-A	WE31-HMD03-T2-A

MODEL CHART - HAND OPERATED & PNEUMATIC ACTUATOR						
Example	WE31	-CSR02	-T1	-A	A	00
Series	WE31					316 SS 3-way NPT
Size and Range		CHD00 DHD00 EHD00 FHD00 GHD00 HHD00 CDA02 DDA02 EDA03 FDA03 GDA04 HDA04 CSR02 DSR03 ESR04 FSR05 GSR06 HSR07				1/2" hand operated 3/4" hand operated 1" hand operated 1-1/4" hand operated 1-1/2" hand operated 2" hand operated 1/2" double acting 3/4" double acting 1" double acting 1-1/4" double acting 1-1/2" double acting 2" double acting 1/2" spring return 3/4" spring return 1" spring return 1-1/4" spring return 1-1/2" spring return 2" spring return
Valve Position			T1 T2 T3 T4 L1			Flow path A Flow path B Flow path C Flow path D Flow path E
Solenoid				N A		No solenoid NEMA 4X NAMUR solenoid
Solenoid Voltage				N A B C D E		No solenoid 110 VAC 220 VAC 24 VAC 24 VDC 12 VDC
Positioner and Switches					00 01 02 03 04 06 07 08 09	None 42AD0 exp limit switch 45VD0 exp position transmitter 42AD0-B ATEX limit switch 42AD0-IE IECEX limit switch QV-210101 poly limit switch VPS and P1 prox switch 265ER-D5 positioner 285ER-D5 smart positioner

ACCESSORIES	
Model	Description
AFR4	Air filter regulator 0 to 120 psi
VB-01	Volume booster

MODEL CHART - ELECTRIC ACTUATOR					
Example	WE31	-DMI02	-T2	-A	WE31-DMI02-T2-A
Series	WE31				316 SS 3-way NPT
Size and Range		CTD01 DTD01 ETD02 FTD02 GTD03 HTD03 CMD01 DMD01 EMD02 FMD02 GMD03 HMD03 CTI01 DTI02 ETI02 FTI04 GTI05 HTI06 CMI01 DMI02 EMI02 FMI04 GMI05 HMI06			1/2" NEMA 4X two-position 3/4" NEMA 4X two-position 1" NEMA 4X two-position 1-1/4" NEMA 4X two-position 1-1/2" NEMA 4X two-position 2" NEMA 4X two-position 1/2" NEMA 4X modulating 3/4" NEMA 4X modulating 1" NEMA 4X modulating 1-1/4" NEMA 4X modulating 1-1/2" NEMA 4X modulating 2" NEMA 4X modulating 1/2" exp two-position 3/4" exp two-position 1" exp two-position 1-1/4" exp two-position 1-1/2" exp two-position 2" exp two-position 1/2" exp electric modulating 3/4" exp electric modulating 1" exp electric modulating 1-1/4" exp electric modulating 1-1/2" exp electric modulating 2" exp electric modulating
Valve Position			T1 T2 T3 T4 L1		Flow path A Flow path B Flow path C Flow path D Flow path E
Actuator Voltage				A B C D	110 VAC 220 VAC 24 VAC 24 VDC

REPAIR KIT	
Model	Valve Series and Size
VRK-36	WE31-1/2"
VRK-37	WE31-3/4"
VRK-38	WE31-1"
VRK-40	WE31-1-1/2"
VRK-41	WE31-2"
Parts List - Included in Kit	
1 PTFE thrust washer	
1 FKM O-ring	
2 PTFE stem packing	
2 PTFE seals	
2 RTFE seats	

"T" Port Ball

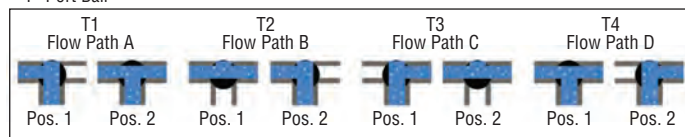

"L" Port Ball

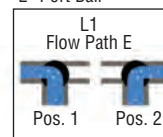

Valves,  
Ball, Automated

# 3-WAY NPT BRASS BALL VALVES

Full Port, Electric or Pneumatic Actuators



WE35-DHD00-T1



WE35-DDA02-L1



WE35-DDA02-T1-AA01



WE35-DTD01-T3-A



The **Series WE35 3-Way NPT Brass Ball Valves** incorporate a full port 3-way brass ball valve for great flow rates with minimal pressure drop. The valve features a blowout proof stem for added safety, reinforced PTFE seats and seals for longer life, and a brass ball for better performance. Actuators are direct mounted creating a compact assembly for tight spaces.

The Series WE35 can be configured with either an electric or pneumatic actuator. Electric actuators are available in weatherproof or explosion-proof, a variety of supply voltages, and two-position or modulating control. Two-position actuators use the supply voltage to drive the valve open or closed, while the modulating actuator accepts a 4 to 20 mA input for valve positioning. Actuators feature thermal overload protection and permanently lubricated gear train.

The pneumatic double acting actuator uses an air supply to drive the valve open and closed. The actuator has two supply ports, with one driving the valve open and the other driving the valve closed. Spring return pneumatic actuators use the air supply to open the valve and internally loaded springs return the valve to the closed position. Also available is the SN solenoid valve to electrically switch the air supply pressure between the air supply ports for opening and closing the valve. Actuators are constructed of anodized and epoxy coated aluminum for years of corrosion free service.

## FEATURES/BENEFITS

- Capable of being configured to fit most applications
- Limit switches can be mounted to manual valves for remote monitoring
- Weatherproof or explosion-proof electric actuators
- Double acting or spring return anodized aluminum pneumatic actuators
- Full port design reduces the pressure drop across the valve

## APPLICATIONS

- Gas or liquid flow control
- Ideal for quick bubble tight shut-off
- Mixing or diverting liquids and gases

## SPECIFICATIONS

### VALVE

**Service:** Compatible liquids and gases.

**Body:** 3-way.

**Line Sizes:** 1/2 to 2".

**End Connections:** Female NPT.

**Pressure Limits:** 600 psi (41 bar) WOG.

**Wetted Materials:** Body, ball, and stem: Brass; Seat, seal, and packing: PTFE.

**Temperature Limits:** -20 to 425°F (-30 to 220°C).

**Other Materials:** O-ring: NBR; Handle, stem nut, ferrule: SS; Handle Sleeve: Vinyl; Body and cap: Nickel plated.

**Agency Approvals:** Meets the technical requirements of EU Directive 2011/65/ EU (RoHS II).

### ACTUATORS

#### Pneumatic "DA" and "SR" Series

**Type:** DA series is a double acting and SR series is a spring return (rack and pinion).

**Normal Supply Pressure:** DA: 40 to 115 psi (2.7 to 7.9 bar); SR: 80 psi (5.5 bar).

**Maximum Supply Pressure:** 120 psi (8.6 bar).

**Air Connections:** DA02 to DA03: 1/4" female NPT; SR02 to SR04: 1/4" female NPT.

**Housing Material:** Anodized aluminum body and epoxy coated aluminum end caps.

**Temperature Limits:** -40 to 176°F (-40 to 80°C).

**Accessory Mounting:** NAMUR standard.

#### Electric "TD" and "MD" Series

**Power Requirements:** 110 VAC, 220 VAC, 24 VAC, or 24 VDC (MD models not available in 24 VDC).

**Power Consumption:** See instruction manual.

**Cycle Time (per 90°):** TD01: 4 s; MD01: 10 s; TD02: 20 s).

**Duty Rating:** 85%.

**Enclosure Rating:** NEMA 4X (IP67).

**Housing Material:** Powder coated aluminum.

**Temperature Limits:** -22 to 140°F (-30 to 60°C).

**Electrical Connection:** 1/2" female NPT.

**Modulating Input:** 4-20 mA.

**Standard Features:** Manual override, position indicator, and TD models come with two limit switches.

#### Electric "TI" and "MI" Series

**Power Requirements:** 110 VAC, 220 VAC, 24 VAC, 24 VDC.

**Power Consumption:** See instruction manual.

**Cycle Time (per 90°):** See instruction manual.

**Duty Rating:** See instruction manual.

**Enclosure Rating:** NEMA 7, designed to meet hazardous locations: Class I, Group C & D; Class II, Group E, F & G; Division I & II.

**Housing Material:** Powder coated aluminum.

**Temperature Limits:** -40 to 140°F (-40 to 60°C).

**Electrical Connection:** 1/2" female NPT.

**Modulating Input:** 4-20 mA.

**Standard Features:** Position indicator and two limit switches.

# 3-WAY NPT BRASS BALL VALVES

Full Port, Electric or Pneumatic Actuators

MODEL CHART						
Size	Cv (gal/min)	Popular Hand Operated Model	Popular Double Acting Pneumatic Model	Popular Spring Return Pneumatic Model	Popular NEMA 4X Two Position Electric (110 VAC) Model	Popular NEMA 4X Modulating Electric (110 VAC) Model
1/2"	13	WE35-CHD00-T1	WE35-CDA02-T2	WE35-CSR02-T2	WE35-CTD01-T2-A	WE35-CMD01-T2-A
3/4"	37	WE35-DHD00-T1	WE35-DDA02-T2	WE35-DSR02-T2	WE35-DTD01-T2-A	WE35-DMD01-T2-A
1"	49	WE35-EHD00-T1	WE35-EDA02-T2	WE35-ESR03-T2	WE35-ETD01-T2-A	WE35-EMD01-T2-A
1-1/4"	59	WE35-FHD00-T1	WE35-FDA03-T2	WE35-FSR03-T2	WE35-FTD01-T2-A	WE35-FMD01-T2-A
1-1/2"	100	WE35-GHD00-T1	WE35-GDA03-T2	WE35-GSR03-T2	WE35-GTD01-T2-A	WE35-GMD01-T2-A
2"	115	WE35-HHD00-T1	WE35-HDA03-T2	WE35-HSR04-T2	WE35-HTD02-T2-A	WE35-HMD02-T2-A

MODEL CHART - HAND OPERATED & PNEUMATIC ACTUATOR						
Example	WE35	-CSR02	-T1	-A	A	00
Series	WE35					Brass 2-piece NPT
Size and Range		CHD00 DHD00 EHD00 FHD00 GHD00 HHD00 CDA02 DDA02 EDA02 FDA03 GDA03 HDA03 CSR02 DSR02 ESR03 FSR03 GSR03 HSR04				1/2" hand operated 3/4" hand operated 1" hand operated 1-1/4" hand operated 1-1/2" hand operated 2" hand operated 1/2" double acting 3/4" double acting 1" double acting 1-1/4" double acting 1-1/2" double acting 2" double acting 1/2" spring return 3/4" spring return 1" spring return 1-1/4" spring return 1-1/2" spring return 2" spring return
Valve Position			T1 T2 T3 T4 L1			Flow path A Flow path B Flow path C Flow path D Flow path E
Solenoid				N A		No solenoid NEMA 4X NAMUR solenoid
Solenoid Voltage					N A B C D E	No solenoid 110 VAC 220 VAC 24 VAC 24 VDC 12 VDC
Positioner and Switches						00 None 01 42AD0 exp limit switch 02 45VD0 exp position transmitter 03 42AD0-B ATEX limit switch 04 42AD0-IE IECEX limit switch 06 QV-210101 poly limit switch 07 VPS and P1 prox switch 08 265ER-D5 positioner 09 285ER-D5 smart positioner

MODEL CHART - ELECTRIC ACTUATOR				
Example	WE35	-GMD01	-T2	-A
Series	WE35			
Size and Range		CTD01 DTD01 ETD01 FTD01 GTD01 HTD02 CMD01 DMD01 EMD01 FMD01 GMD01 HMD02 CTI01 DTI01 ETI02 FTI02 GTI02 HTI03 CMI01 DMI01 EMI02 FMI02 GMI02 HMI03		
Valve Position			T1 T2 T3 T4 L1	
Actuator Voltage				A B C D

ACCESSORIES	
Model	Description
AFR4	Air filter regulator, 0 to 120 psi

Valves,  
Ball, Automated

# 3-WAY TRI-CLAMP STAINLESS STEEL BALL VALVES

## Cavity Filled, Electric and Pneumatic Actuators



WE33-DHD00-T2



WE33-ESR03-T1-NN07



WE33-DDA01-L1-AA06



WE33-DTD01-T3-A



WE33-DTI01-T2-A



The **Series WE33 3-Way Tri-Clamp Stainless Steel Ball Valves** incorporate a full port 3-way tri-clamp SS ball valve for great flow rates with minimal pressure drop. The valve features a blowout-proof stem for added safety, reinforced PTFE seats and seals for longer life, and a 316 SS (ASTM CF8M) ball for better performance. Actuators are direct mounted creating a compact assembly for tight spaces. Limit switches are able to be mounted directly to the valves allowing for remote position indication.

The Series WE33 can be configured with either an electric or pneumatic actuator. Electric actuators are available in weatherproof or explosion-proof, a variety of supply voltages and two-position or modulating control. Two-position actuators use the supply voltage to drive the valve open or close, while the modulating actuator accepts a 4 to 20 mA input for valve positioning. Actuators feature thermal overload protection and permanently lubricated gear train.

The pneumatic double acting actuator uses an air supply to drive the valve open and closed. The actuator has two supply ports, with one driving the valve open and the other driving the valve closed. Spring return pneumatic actuators use the air supply to open the valve, and internally loaded springs return the valve to the closed position. Also available is the SN solenoid valve to electrically switch the air supply pressure between the air supply ports for opening and closing the valve. Actuators are constructed of anodized and epoxy coated aluminum for years of corrosion free service.

### FEATURES/BENEFITS

- Capable of being configured to fit any application
- Limit switches can be mounted to manual valves for remote monitoring
- Cavity filled valve for sanitary applications
- Weatherproof or explosion-proof electric actuators
- Double acting or spring return anodized aluminum pneumatic actuators
- Full port design reduces the pressure drop across the valve

### APPLICATIONS

- Gas or liquid flow control
- Ideal for quick bubble tight shut-off
- Mixing or diverting liquids and gases

### SPECIFICATIONS

#### VALVE

**Service:** Compatible liquids and gases.

**Body:** 3-way.

**Line Sizes:** 1/2 to 2".

**End Connections:** Tri-clamp ends.

**Pressure Limits:** 20" Hg to 1000 psi (-0.7 to 69 bar) up to 250°F.

**Wetted Materials:** Body and ball: 316 SS (CF8M); Stem: 316 SS; Seat: RTFE/PTFE; Seal, Washer, and Packing: PTFE.

**Temperature Limits:** -20 to 392°F (-29 to 200°C).

**Other Materials:** O-ring:

Fluoroelastomer; Handle: 304 SS; Washer: 301 SS; Stem Nut, Locking Device, Gland Ring: 304 SS; Handle Sleeve: PVC.

**Agency Approvals:** Meets the technical requirements of EU Directive 2011/65/EU (RoHS II).

#### ACTUATORS

##### Pneumatic "DA" and "SR" Series

**Type:** DA series is double acting and SR series is spring return (rack and pinion).

**Normal Supply Pressure:** DA: 40 to 115 psi (2.7 to 7.9 bar); SR: 80 psi (5.5 bar).

**Maximum Supply Pressure:** 120 psi (8.6 bar).

**Air Connections:** DA01: 1/8" female NPT; DA02 to DA03: 1/4" female NPT; SR02 to SR04: 1/4" female NPT.

**Housing Material:** Anodized aluminum body and epoxy coated aluminum end caps.

**Temperature Limits:** -40 to 176°F (-40 to 80°C).

**Accessory Mounting:** NAMUR standard.

##### Electric "TD" and "MD" Series

**Power Requirements:** 110 VAC, 220 VAC, 24 VAC or 24 VDC (MD models not available in 24 VDC).

**Power Consumption:** See instruction manual.

**Cycle Time (per 90°):** TD01: 4 s; MD01: 10 s; TD02 and MD02: 20 s.

**Duty Rating:** 85%.

**Enclosure Rating:** NEMA 4X (IP67).

**Housing Material:** Powder coated aluminum.

**Temperature Limits:** -22 to 140°F (-30 to 60°C).

**Electrical Connection:** 1/2" female NPT.

**Modulating Input:** 4-20 mA.

**Standard Features:** Manual override, position indicator, and TD models come with two limit switches.

##### Electric "TI" and "MI" Series

**Power Requirements:** 110 VAC, 220 VAC, 24 VAC or 24 VDC.

**Power Consumption:** See instruction manual.

**Cycle Time (per 90°):** See instruction manual.

**Duty Rating:** See instruction manual.

**Enclosure Rating:** NEMA 7, designed to meet hazardous locations: Class I, Group C & D; Class II, Group E, F & G; Division I & II.

**Housing Material:** Powder coated aluminum.

**Temperature Limits:** -40 to 140°F (-40 to 60°C).

**Electrical Connection:** 1/2" female NPT.

**Modulating Input:** 4-20 mA.

**Standard Features:** Position indicator and two limit switches.



# 3-WAY TRI-CLAMP STAINLESS STEEL BALL VALVES

Cavity Filled, Electric and Pneumatic Actuators

MODEL CHART						
Size	Cv (gal/min)	Popular Hand Operated Model	Popular Double Acting Pneumatic Model	Popular Spring Return Pneumatic Model	Popular NEMA 4X Two Position Electric (110 VAC) Model	Popular NEMA 4X Modulating Electric (110 VAC) Model
1/2"	14.39	WE33-CHD00-T2	WE33-CDA01-T2	WE33-CSR02-T2	WE33-CTD01-T2-A	WE33-CMD01-T2-A
3/4"	42.25	WE33-DHD00-T2	WE33-DDA01-T2	WE33-DSR02-T2	WE33-DTD01-T2-A	WE33-DMD01-T2-A
1"	86.17	WE33-EHD00-T2	WE33-EDA02-T2	WE33-ESR03-T2	WE33-ETD01-T2-A	WE33-EMD01-T2-A
1-1/2"	223.61	WE33-GHD00-T2	WE33-GDA02-T2	WE33-GSR04-T2	WE33-GTD02-T2-A	WE33-GMD02-T2-A
2"	437.98	WE33-HHD00-T2	WE33-HDA03-T2	WE33-HSR04-T2	WE33-HTD02-T2-A	WE33-HMD02-T2-A

MODEL CHART - HAND OPERATED & PNEUMATIC ACTUATOR						
Example	WE33	-CSR02	-T4	-N	N	07
Series	WE33					316 SS 3-way tri-clamp
Size and Actuator		CHD00 DHD00 EHD00 GHD00 HHD00 CDA01 DDA01 EDA02 GDA02 HDA03 CSR02 DSR02 ESR03 GSR04 HSR04				1/2" hand operated 3/4" hand operated 1" hand operated 1-1/2" hand operated 2" hand operated 1/2" double acting 3/4" double acting 1" double acting 1-1/2" double acting 2" double acting 1/2" spring return 3/4" spring return 1" spring return 1-1/2" spring return 2" spring return
Valve Position			T1 T2 T3 T4 L1			Flow path A Flow path B Flow path C Flow path D Flow path E
Solenoid					N A	No solenoid NEMA 4X NAMUR solenoid
Solenoid Voltage					N A B C D E	No solenoid 110 VAC 220 VAC 24 VAC 24 VDC 12 VDC
Positioner and Switches						00 None 01 42AD0 exp limit switch 02 45VD0 exp position transmitter 03 42AD0-B ATEX limit switch 04 42AD0-IE IECEX limit switch 06 QV-210101 poly limit switch 07 VPS and P1 prox switch 08 265ER-D5 positioner 09 285ER-D5 smart positioner

ACCESSORIES	
Model	Description
AFR4	Air filter regulator 0 to 120 psi
VB-01	Volume booster

MODEL CHART - ELECTRIC ACTUATOR					
Example	WE33	-DMD01	-T2	-B	WE33-DMD01-T2-B
Series	WE33				316 SS 3-way tri-clamp
Size and Actuator		CTD01 DTD01 ETD01 GTD02 HTD02 CMD01 DMD01 EMD01 GMD02 HMD02 CTI01 DTI01 ETI02 GTI02 HTI03 CMI01 DMI01 EMI02 GMI02 HMI03			1/2" NEMA 4X two-position 3/4" NEMA 4X two-position 1" NEMA 4X two-position 1-1/2" NEMA 4X two-position 2" NEMA 4X two-position 1/2" NEMA 4X modulating 3/4" NEMA 4X modulating 1" NEMA 4X modulating 1-1/2" NEMA 4X modulating 2" NEMA 4X modulating 1/2" exp two-position 3/4" exp two-position 1" exp two-position 1-1/2" exp two-position 2" exp two-position 1/2" exp electric modulating 3/4" exp electric modulating 1" exp electric modulating 1-1/2" exp electric modulating 2" exp electric modulating
Valve Position			T1 T2 T3 T4 L1		Flow path A Flow path B Flow path C Flow path D Flow path E
Actuator Voltage				A B C D	110 VAC 220 VAC 24 VAC 24 VDC

REPAIR KIT	
Model	Valve Series and Size
VRK-42	WE33-1/2"
VRK-43	WE33-3/4"
VRK-44	WE33-1"
VRK-45	WE33-1-1/2"
VRK-46	WE33-2"

Parts List - Included in Kit	
1	PTFE thrust washer
1	FKM O-ring
2	PTFE stem packing
2	PTFE seals
2	RTFE seats

"T" Port Ball

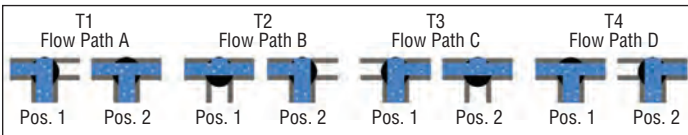

"L" Port Ball

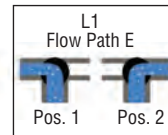

Valves,  
Ball, Automated

# 3-WAY FLANGED STAINLESS STEEL BALL VALVES

150# ANSI Flange, Vented Ball, Electric or Pneumatic Actuators

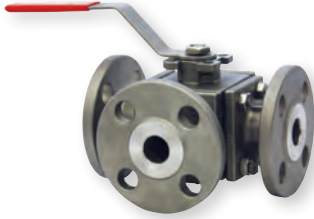

WE34-DHD00-L1



WE34-DDA03-T2



WE34-DDA03-T1-AA01



WE34-DDA03-T2-NN08



WE34-DTI03-T3-A



The **Series WE34 3-Way Flanged Stainless Steel Ball Valves** incorporate a full port 3-way flanged SS ball valve for great flow rates with minimal pressure drop. The valve features a blowout-proof stem for added safety, reinforced PTFE seats and seals for longer life, and a 316 SS (ASTM CF8M) ball for better performance. Actuators are direct mounted creating a compact assembly for tight spaces. Limit switches are able to be mounted directly to the valves allowing for remote position indication.

The Series WE34 can be configured with either an electric or pneumatic actuator. Electric actuators are available in weatherproof or explosion-proof, a variety of supply voltages and two-position or modulating control. Two-position actuators use the supply voltage to drive the valve open or closed, while the modulating actuator accepts a 4-20 mA input for valve positioning. Actuators feature thermal overload protection and permanently lubricated gear train.

The pneumatic double acting actuator uses an air supply to drive the valve open and closed. The actuator has two supply ports, with one driving the valve open and the other driving the valve closed. Spring return pneumatic actuators use the air supply to open the valve and internally loaded springs return the valve to the closed position. Also available is the SN solenoid valve to electrically switch the air supply pressure between the air supply ports for opening and closing the valve. Actuators are constructed of anodized and epoxy coated aluminum for years of corrosion free service.

## FEATURES/BENEFITS

- Capable of being configured to fit any application
- Limit switches can be mounted to manual valves for remote monitoring
- Vented ball to reduce operating torque
- Weatherproof or explosion-proof electric actuators
- Double acting or spring return anodized aluminum pneumatic actuators
- Full port design reduces the pressure drop across the valve
- Eliminates threads and reduces installation and maintenance time

## APPLICATIONS

- Gas or liquid flow control
- Ideal for quick bubble tight shut-off
- Mixing or diverting liquids and gases

## SPECIFICATIONS

### VALVE

**Service:** Compatible liquids and gases.

**Body:** 3-way.

**Line Sizes:** 1/2 to 3".

**End Connections:** 150# ANSI flange.

**Pressure Limits:** 28" Hg to 275 psi (-0.7 to 19 bar) up to 392°F.

**Wetted Materials:** Body and ball: 316 SS (CF8M); Stem: 316 SS; Seat: RTFE/PTFE; Seal, Washer, and Packing: PTFE.

**Temperature Limits:** -20 to 392°F (-29 to 200°C).

**Other Materials:** O-ring:

Fluoroelastomer; Handle: 304 SS; Washer: 301 SS; Stem Nut, Locking Device, Gland Ring: 304 SS; Handle Sleeve: PVC.

**Agency Approvals:** Meets the technical requirements of EU Directive 2011/65/ EU (RoHS II).

### ACTUATORS

#### Pneumatic "DA" and "SR" Series

**Type:** DA series is double acting and SR series is spring return (rack and pinion).

**Normal Supply Pressure:** DA: 40 to 115 psi (2.7 to 7.9 bar); SR: 80 psi (5.5 bar).

**Maximum Supply Pressure:** 120 psi (8.6 bar).

**Air Connections:** DA01: 1/8" female NPT; DA02 to DA08: 1/4" female NPT; SR03 to SR09: 1/4" female NPT.

**Housing Material:** Anodized aluminum body and epoxy coated aluminum end caps.

**Temperature Limits:** -40 to 176°F (-40 to 80°C).

**Accessory Mounting:** NAMUR standard.

#### Electric "TD" and "MD" Series

**Power Requirements:** 110 VAC, 220 VAC, 24 VAC or 24 VDC (MD models not available in 24 VDC).  
**Power Consumption:** See instruction manual.

**Cycle Time (per 90°):** TD01: 4 s; MD01: 10 s; TD02 and MD02: 20 s; TD03 and MD03: 30 s; TD04 and MD04: 30 s.

**Duty Rating:** 85%.

**Enclosure Rating:** NEMA 4X (IP67).

**Housing Material:** Powder coated aluminum.

**Temperature Limits:** -22 to 140°F (-30 to 60°C).

**Electrical Connection:** 1/2" female NPT.

**Modulating Input:** 4-20 mA.

**Standard Features:** Manual override, position indicator, and TD models come with two limit switches.

#### Electric "TI" and "MI" Series

**Power Requirements:** 110 VAC, 220 VAC, 24 VAC or 24 VDC.

**Power Consumption:** See instruction manual.

**Cycle Time (per 90°):** See instruction manual.

**Duty Rating:** See instruction manual.

**Enclosure Rating:** NEMA 7, designed to meet hazardous locations: Class I, Group C & D; Class II, Group E, F & G; Division I & II.

**Housing Material:** Powder coated aluminum.

**Temperature Limits:** -40 to 140°F (-40 to 60°C).

**Electrical Connection:** 1/2" female NPT.

**Modulating Input:** 4-20 mA.

**Standard Features:** Position indicator and two limit switches.

# 3-WAY FLANGED STAINLESS STEEL BALL VALVES

150# ANSI Flange, Vented Ball, Electric or Pneumatic Actuators

MODEL CHART						
Size	Cv (gal/min)	Popular Hand Operated Model	Popular Double Acting Pneumatic Model	Popular Spring Return Pneumatic Model	Popular NEMA 4X Two Position Electric (110 VAC) Model	Popular NEMA 4X Modulating Electric (110 VAC) Model
1/2"	26	WE34-CHD00-T2	WE34-CDA02-T2	WE34-CSR03-T2	WE34-CTD02-T2-A	WE34-CMD01-T2-A
3/4"	50	WE34-DHD00-T2	WE34-DDA02-T2	WE34-DSR03-T2	WE34-DTD02-T2-A	WE34-DMD01-T2-A
1"	94	WE34-EHD00-T2	WE34-EDA03-T2	WE34-ESR05-T2	WE34-ETD02-T2-A	WE34-EMD02-T2-A
1-1/2"	260	WE34-GHD00-T2	WE34-GDA05-T2	WE34-GSR06-T2	WE34-GTD03-T2-A	WE34-GMD03-T2-A
2"	380	WE34-HHD00-T2	WE34-HDA06-T2	WE34-HSR07-T2	WE34-HTD03-T2-A	WE34-HMD03-T2-A
2-1/2"	650	WE34-IHD00-T2	WE34-IDA07-T2	WE34-ISR08-T2	WE34-ITD04-T2-A	WE34-IMD04-T2-A
3"	1000	WE34-JHD00-T2	WE34-JDA08-T2	WE34-JSR09-T2	WE34-JTD04-T2-A	WE34-JMD04-T2-A

MODEL CHART - HAND OPERATED & PNEUMATIC ACTUATOR						
Example	WE34	-JDA08	-T1	-A	B	00
<b>Series</b>	WE34					316 SS 3-way 150# ANSI flange
<b>Size and Actuator</b>		CHD00 DHD00 EHD00 GHD00 HHD00 IHD00 JHD00 CDA02 DDA02 EDA03 GDA05 HDA06 IDA07 JDA08 CSR03 DSR03 ESR05 GSR06 HSR07 ISR08 JSR09				1/2" hand operated 3/4" hand operated 1" hand operated 1-1/2" hand operated 2" hand operated 2-1/2" hand operated 3" hand operated 1/2" double acting 3/4" double acting 1" double acting 1-1/2" double acting 2" double acting 2-1/2" double acting 3" double acting 1/2" spring return 3/4" spring return 1" spring return 1-1/2" spring return 2" spring return 2-1/2" spring return 3" spring return
<b>Valve Position</b>			T1 T2 T3 T4 L1			Flow path A Flow path B Flow path C Flow path D Flow path E
<b>Solenoid</b>				N A		No solenoid NEMA 4X NAMUR solenoid
<b>Solenoid Voltage</b>				N A B C D E		No solenoid 110 VAC 220 VAC 24 VAC 24 VDC 12 VDC
<b>Positioner and Switches</b>					00 01 02 03 04 06 07 08 09	None 42AD0 exp limit switch 45VD0 exp position transmitter 42AD0-B ATEX limit switch 42AD0-IE IECEX limit switch QV-210101 poly limit switch VPS and P1 prox switch 265ER-D5 positioner 285ER-D5 smart positioner

ACCESSORIES	
Model	Description
AFR4	Air filter regulator 0 to 120 psi
VB-01	Volume booster

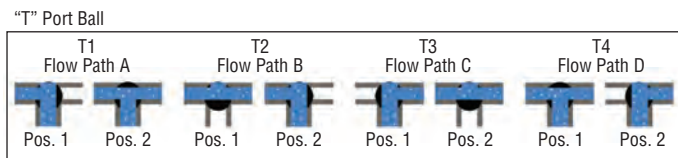

MODEL CHART - ELECTRIC ACTUATOR					
Example	WE34	-HMD03	-T3	-A	WE34-HMD03-T3-A
<b>Series</b>	WE34				316 SS 3-way 150# ANSI flange
<b>Size and Actuator</b>		CTD02 DTD02 ETD02 GTD03 HTD03 ITD04 JTD04 CMD01 DMD01 EMD02 GMD03 HMD03 IMD04 JMD04 CTI02 DTI02 ETI03 GTI05 HTI06 ITI06 JTI08 CMI02 DMI02 EMI03 GMI05 HMI06 IMI06 JMI08			1/2" NEMA 4X two-position 3/4" NEMA 4X two-position 1" NEMA 4X two-position 1-1/2" NEMA 4X two-position 2" NEMA 4X two-position 2-1/2" NEMA 4X two-position 3" NEMA 4X two-position 1/2" NEMA 4X modulating 3/4" NEMA 4X modulating 1" NEMA 4X modulating 1-1/2" NEMA 4X modulating 2" NEMA 4X modulating 2-1/2" NEMA 4X modulating 3" NEMA 4X modulating 1/2" exp two-position 3/4" exp two-position 1" exp two-position 1-1/2" exp two-position 2" exp two-position 2-1/2" exp two-position 3" exp two-position 1/2" exp electric modulating 3/4" exp electric modulating 1" exp electric modulating 1-1/2" exp electric modulating 2" exp electric modulating 2-1/2" exp electric modulating 3" exp electric modulating
<b>Valve Position</b>			T1 T2 T3 T4 L1		Flow path A Flow path B Flow path C Flow path D Flow path E
<b>Actuator Voltage</b>				A B C D	110 VAC 220 VAC 24 VAC 24 VDC

REPAIR KIT	
Model	Valve Series and Size
VRK-50	WE34-1/2"
VRK-51	WE34-3/4"
VRK-52	WE34-1"
VRK-54	WE34-1-1/2"
VRK-55	WE34-2"
VRK-56	WE34-2-1/2"
VRK-57	WE34-3"
Parts List - Included in Kit	
1 PTFE thrust washer	
1 FKM O-ring	
2 PTFE stem packing	
2 PTFE seals	
2 RTFE seats	

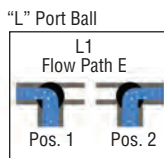

# 3-WAY PLASTIC AUTOMATED BALL VALVES

## Electric and Pneumatic Actuators



Size	Position				
	A	B	C	D	E
1/2"	3.85	2.45	4.55	13.7	5.11
3/4"	9.50	6.65	10.2	26.6	10.5
1"	14.4	9.80	17.2	53.2	18.6
1-1/4"	27.3	18.9	32.2	73.5	33.3
1-1/2"	33.3	23.1	42.0	119	43.4
2"	63.0	43.4	84.0	224	85.4

Cv values

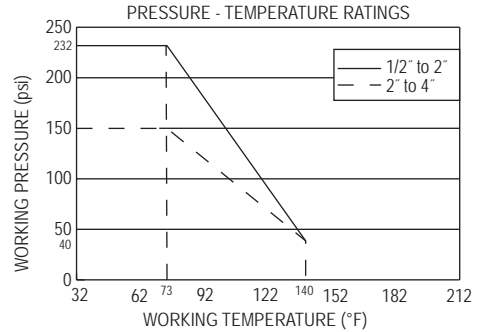

The Series 3PBV 3-Way Plastic Automated Ball Valves are ideal for mixing or diverting services in industrial, chemical, turf and irrigation, and pool and spa applications, as well as for use with potable water. The valve features a 3-seat design for efficient automation, reinforced TFE seats and EPDM seals for longer life, and an all PVC construction for heavyweight durability at a lightweight cost. Valves also come standard with field selectable NPT or socket process connections.

The 3PBV is an economical automated valve package with either an electric or pneumatic actuator. Electrically actuated models are weatherproof, NEMA 4 (IP56), powered by standard 115 VAC supply, and are available in either two-position or proportional control. Two-position actuators use the 115 VAC input to drive each of the valve ports open or closed, while the modulating actuator accepts a 4-20 mA input for infinite valve positioning. Actuator features include thermal overload protection to withstand stall conditions, visual position indication and a permanently lubricated gear train.

The pneumatic double acting actuator uses an air supply to drive each of the actuator ports. Spring return pneumatic actuators use the air supply to drive the valve stem one direction, and internally loaded springs return the valve to its original position. Also available is the SV3 solenoid valve to electrically switch the supply pressure between the air supply ports. Actuators are constructed of anodized aluminum and are epoxy coated for years of corrosion free service.

### FEATURES/BENEFITS

- Available with a variety of electric and pneumatic actuators
- Field selectable socket or NPT connections

### APPLICATIONS

- Gas or liquid flow control
- Mixing or diverting liquids and gases

### HOW TO ORDER:

1. Select **Model Number** to specify pipe size and actuator.
2. Choose a **Port Configuration** to determine valve flow path.  
**Example:** 3PBVPSR204-L1

### MODEL CHART

Size	Cv	Double Acting Pneumatic	Spring Return Pneumatic	Two Position Electric	Modulating Electric
		Model*	Model*	Model*	Model*
1/2"	See	3PBVPDA102	3PBVPSR202	3PBVPU1102	3PBVPV1202
3/4"	Chart	3PBVPDA103	3PBVPSR203	3PBVPU1103	3PBVPV1203
1"	Below	3PBVPDA104	3PBVPSR204	3PBVPU1104	3PBVPV1204
1-1/4"		3PBVPDA105	3PBVPSR205	3PBVPU1105	3PBVPV1205
1-1/2"		3PBVPDA206	3PBVPSR306	3PBVPU1206	3PBVPV1206
2"		3PBVPDA207	3PBVPSR307	3PBVPU1207	3PBVPV1207

\*Complete model includes **Port Configuration** - see "How to Order".

### OPTIONS

To order add suffix:	Description	Actuator Size*
-EX	Explosion proof electric actuators	XX1-XX6

\*Example: Third digit in U12 or V12 is the size

**Note:** For optional electric actuator supply voltages, contact factory for model number change

### SPECIFICATIONS

**Service:** Compatible liquids or gases.

**Body:** 3-way.

**Line Size:** 1/2" to 2".

**End Connections:** Female NPT or socket (field-selectable).

**Pressure Limit:** 1/2" to 1": 232 psi (16.0 bar) @ 73°F (23°C); 1-1/4" to 2": 150 psi (10.3 bar) @ 73°F (23°C) WOG; Vacuum: 29" Hg. See chart for curve.

**Wetted Materials:** Body, end connectors: PVC; Ball, stem: PVC; Seat: TFE; Stem seal: EPDM.

**Temperature Limit:** 32 to 140°F (0 to 60°C).

### ACTUATORS

#### Electric

**Power Requirements:** 120 VAC, 50/60 Hz, single phase. Optional 220 VAC, 24 VAC, 12 VDC, and 24 VDC.

**Power Consumption (Locked Rotor Current):** Two position: 1/2" to 1-1/2":

.55 A, 2": 0.75 A; Modulating: 0.75 A.

**Cycle Time:** (per 90°): Two position: 1/2" to 1-1/2": 2.5 s, 2": 5 s; Modulating: 5 s.

**Duty Cycle:** Two position: 1/2" to 1-1/2": 75%, 2": 25%; Modulating: 75%.

**Enclosure Rating:** NEMA 4. Optional NEMA 7 (Class 1, Div. II groups A, B, C, D).

**Housing Material:** Aluminum with thermal bonding polyester powder finish.

**Temperature Limit:** 0 to 150°F (-18 to 65°C).

**Conduit Connection:** 1/2" female NPT.

**Modulating Input:** 4-20 mA.

**Standard Features:** Manual override and visual position indicator except modulating units.

#### Pneumatic "DA" and "SR" Series

**Type:** DA series is double acting and SR series is spring return (rack and pinion).

**Normal Supply Pressure:** 80 psi (5.5 bar).

**Maximum Supply Pressure:** 120 psig (8 bar).

**Air Connections:** DA/SR1 to 5: 1/8" female NPT, all other sizes: 1/4" female NPT.

**Air Consumption (per stroke):** DA1: 2.32 in<sup>3</sup>; DA2, SR2: 9.34 in<sup>3</sup>; SR3: 17.21 in<sup>3</sup>.

**Cycle Time (per 90°):** DA1: .03 s; DA2: .04 s; SR2: .09 s; SR3: .14 s.

**Housing Material:** Anodized aluminum body and epoxy coated aluminum end caps.

**Temperature Limit:** -4 to 180°F (-20 to 82°C).

**Accessory Mounting:** NAMUR standard.

**Standard Features:** Visual position indicator.

### "T" Port Ball

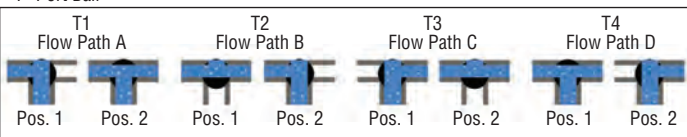

### "L" Port Ball

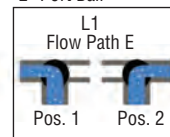

Filters and Regulators: See pages 447-448



# BUTTERFLY VALVE

Low Cost, S.A.E. Flange, Hydraulic Reservoir Shut Off Valve

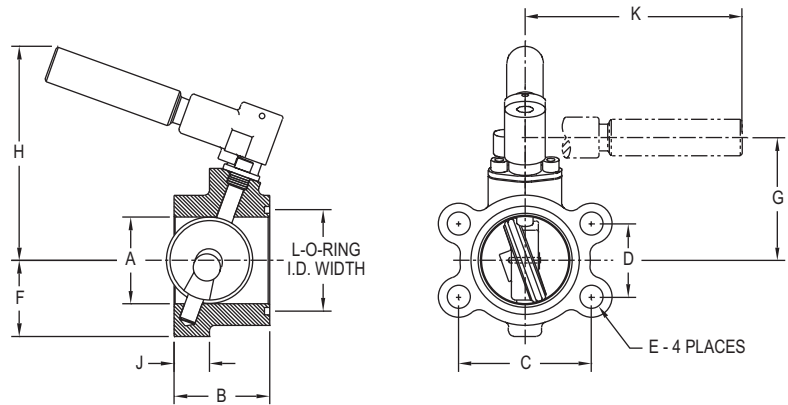

Size	A in [mm]	B in [mm]	C in [mm]	D in [mm]	E in [mm]	F in [mm]	G in [mm]	H in [mm]	J in [mm]	K in [mm]	L in [mm]	I.D. X W.D.
2"	2 [50.80]	2 [50.80]	3-1/16 [77.79]	1-11/16 [42.86]	1/2 [12.70]	1-3/4 [44.45]	2-13/16 [71.44]	5-1/8 [130.18]	13/16 [20.64]	5 [127.00]	2-1/4 [57.15]	1/8 [3.18]
2-1/2"	2-1/2 [63.50]	2 [50.80]	3-1/2 [88.90]	2 [50.80]	1/2 [12.70]	2-1/16 [52.39]	3-1/8 [79.38]	5-1/8 [130.18]	13/16 [20.64]	5 [127.00]	2-3/4 [69.85]	1/8 [3.18]
3"	3 [76.20]	2-1/2 [63.50]	4-3/16 [106.36]	2-7/16 [61.91]	5/8 [15.88]	2-5/16 [58.74]	3-3/8 [85.73]	5-1/8 [130.18]	1-1/16 [26.99]	5 [127.00]	3-3/8 [85.73]	1/8 [3.18]
4"	4 [101.60]	3-1/4 [82.55]	5-1/8 [130.18]	3-1/16 [77.79]	5/8 [15.88]	2-3/4 [69.85]	4 [101.60]	5-5/8 [142.88]	1-1/4 [31.75]	5 [127.00]	4-3/8 [111.13]	1/8 [3.18]
5"	5 [127.00]	4 [101.60]	6 [152.40]	3-5/8 [92.08]	5/8 [15.88]	3-5/16 [84.14]	4-3/8 [111.13]	6 [152.40]	1-1/2 [38.10]	5 [127.00]	5-3/8 [136.53]	1/8 [3.18]

The **Series SAE Butterfly Valve** is an ideal low cost hydraulic reservoir shut off valve. These valves are designed to meet the demanding needs of the fluid power industry. Unique features include an O-ring flange face seal complying with S.A.E. J518 dimensional requirements. This design provides for bubble tight reservoir shut off up to 25 psi (1.72 bar) and a max temperature of 180°F (82.2°C). The compact envelope dimension reduces space requirements. Unit allows for adjustment by incorporating an open/close detent position lock which can be infinitely positioned to achieve a desired flow rate. The unique design resists the vibrations associated with hydraulic pumps and pumping systems. Optional fluoroelastomer seals and locking handle are available.

**FEATURES/BENEFITS**

- Flange face complies with S.A.E. J518 dimensional requirements
- Bubble tight shut-off
- Locking handles are available

**APPLICATIONS**

- Hydraulic reservoir isolation on injection molding or earth moving equipment
- Used to isolate the hydraulic reservoir during maintenance

MODEL CHART	
Model	Flange Size
SAE-20	2"
SAE-25	2-1/2"
SAE-30	3"
SAE-40	4"
SAE-50	5"

OPTIONS	
To order add suffix:	Description
-VIT	Fluoroelastomer O-ring seals
Example: SAE-30-VIT	
-LHR	Locking handle
Example: SAE-30-LHR	

**SPECIFICATIONS**

**Service:** Compatible liquids and gases.  
**Line Size:** 2" to 5".  
**Body Style:** 2-way, lug butterfly.  
**End Connections:** O-ring flange face seal (S.A.E. J518).  
**Pressure Limit:** Shut-off: 25 psi (1.72 bar) bubble tight; Body shell: 500 psi (34.5 bar).  
**Wetted Materials:** Body and disc/vane: Cast iron; O-rings: Buna-N or fluoroelastomer; Stem: Steel.  
**Temperature Limits:** Buna-N: 180°F (82°C); Fluoroelastomer: 300°F (149°C).  
**Agency Approvals:** Meets the technical requirements of EU Directive 2011/65/EU (RoHS II).

## BUTTERFLY VALVES

Lug or Wafer, EPDM or PTFE, Electric or Pneumatic Actuators



WE20-CHD00-LE



WE20-EDA06-LE



WE20-ETD04-LE-A



WE20-CDA04-WP-AA07



WE20-CDA04-WP-NN08



The **Series WE20 Butterfly Valves** are offered in lug or wafer body styles and is equipped with a PTFE or EPDM liner. The most critical aspect of the Series WE20 Butterfly Valves is the cartridge seat design, which alleviates installation problems associated with common "dove tail design" seats. Valve torques are lower and more consistent as the seat dynamics are not dependent on being coupled between two flanges. Precision machining of the disc and body allow the cartridge design to maintain a tighter disc to seat tolerance, providing a perfect low torque seal each and every time the valve is cycled. The seat to disc seal is independent of flange support and capable of full rated dead end service.

Actuators are directly mounted creating a compact assembly for tight spaces. Limit switches are able to be mounted directly to the valves allowing for remote position indication.

The Series WE20 can be configured with either an electric or pneumatic actuator. Electric actuators are available in weatherproof or explosion-proof, a variety of supply voltages and two-position or modulating control. Two-position actuators use the supply voltage to drive the valve open or closed, while the modulating actuator accepts a 4 to 20 mA input for valve positioning. Actuators feature thermal overload protection and permanently lubricated gear train. The pneumatic double acting actuator uses an air supply to drive the valve open and closed. The actuator has two supply ports, with one driving the valve open and the other driving the valve closed. Spring return pneumatic actuators use the air supply to open the valve, and internally loaded springs return the valve to the closed position.

The pneumatic double acting actuator uses an air supply to drive the valve open and closed. The actuator has two supply ports with one driving the valve open and the other driving the valve closed. Spring return pneumatic actuators use the air supply to open the valve and internally loaded springs return the valve to the closed position. Also available is the SV3 solenoid valve to electrically switch the air supply pressure between the air supply ports for opening and closing the valve. Actuators are constructed of anodized and epoxy coated aluminum for years of corrosion free service.

## FEATURES/BENEFITS

- Machined flats attach disc/stem - no pins
- Phenolic backed cartridge seat design for extended service and ease of replacement
- Extended neck for insulation - no fabricated extensions required
- Capable of being configured to fit any application
- Limit switches can be mounted to manual valves for remote monitoring
- Available with a variety of electric and pneumatic actuators

## APPLICATIONS

- Gas or liquid flow control

## SPECIFICATIONS

## VALVE

**Service:** Compatible liquids, gases, and steam.

**Body:** 2-way, wafer or lug butterfly.

**Line Sizes:** 2 to 12".

**End Connections:** Lug and wafer pattern designed for flanges that are ANSI Class 125 (B16.1) and ANSI Class 150 (B16.5) dimension.

**Pressure Limits:** 225 psi (15.5 bar).

**Wetted Materials:** Body Material: Ductile iron; Disc: 316 SS; Seat: EPDM or PTFE; O-ring: EPDM; Stem: 410 SS.

**Temperature Limits:** Disc: EPDM: -50 to 250°F (-46 to 121°C); PTFE: 0 to 300°F (-18 to 149°C).

**Bearings:** Nylatron.

**Operator:** 2 to 6" 10-position locking hand lever; 8 to 12": manual gear.

## ACTUATORS

## Pneumatic "DA" and "SR" Series

**Type:** DA series is double acting and SR series is spring return (rack and pinion).

**Normal Supply Pressure:** DA: 40 to 115 psi (2.7 to 7.9 bar); SR: 70 to 115 psi (4.8 to 7.9 bar).

**Maximum Supply Pressure:** 120 psi (8.6 bar).

**Air Connections:** DA03 thru DA11: 1/4" FNPT; SR03 thru SR11: 1/4" FNPT.

**Housing Material:** Anodized aluminum body and epoxy coated aluminum end caps.

**Temperature Limits:** -40 to 176°F (-40 to 80°C).

**Accessory Mounting:** NAMUR standard.

## Electric "TD" and "MD" Series

**Power Requirements:** 110 VAC, 220 VAC or 24 VDC.

**Power Consumption:** See instruction manual.

**Cycle Time (per 90°):** TD01 and MD01: 4 s; TD02 and MD02: 20 s; TD03 and MD03: 30 s; TD04 and MD04: 30 s; TD05 and MD05: 30 s; TD06 and MD06: 45 s; TD07 and MD07: 30 s.

**Duty Rating:** 85%.

**Enclosure Rating:** NEMA 4X (IP67).

**Housing Material:** Powder coated aluminum.

**Temperature Limits:** -22 to 140°F (-30 to 60°C).

**Electrical Connection:** 1/2" female NPT.

**Modulating Input:** 4-20 mA.

**Standard Features:** Manual override, position indicator, and TD models come with two limit switches.

## Electric "TH and MH Series

**Power Requirements:** 110 VAC, 220 VAC, 24 VAC or 24 VDC.

**Power Consumption:** See instruction manual.

**Cycle Time (per 90°):** See instruction manual.

**Duty Rating:** See instruction manual.

**Enclosure Rating:** NEMA 7, designed to meet hazardous locations: Class I, Group C & D; Class II, Group E, F & G; Division I & II.

**Housing Material:** Powder coated aluminum.

**Temperature Limits:** -22 to 140°F (-30 to 60°C).

**Electrical Connection:** 1/2" female NPT.

**Modulating Input:** 4-20 mA.

**Standard Features:** Position indicator and two limit switches.

# BUTTERFLY VALVES

Lug or Wafer, EPDM or PTFE, Electric or Pneumatic Actuators

MODEL CHART						
Size	Cv (gal/min)	Popular Hand Operated Model	Popular Double Acting Pneumatic Model	Popular Spring Return Pneumatic Model	NEMA 4X Two-Position Electric (110 VAC) Model	NEMA 4X Modulating Electric (110 VAC) Model
2"	135	WE20-AHD00-WE	WE20-ADA03-WE	WE20-ASR04-WE	WE20-ATD02-WE-A	WE20-AMD02-WE-A
2-1/2"	220	WE20-BHD00-WE	WE20-BDA03-WE	WE20-BSR04-WE	WE20-BTD02-WE-A	WE20-BMD02-WE-A
3"	302	WE20-CHD00-WE	WE20-CDA04-WE	WE20-CSR06-WE	WE20-CTD02-WE-A	WE20-CMD02-WE-A
4"	600	WE20-DHD00-WE	WE20-DDA05-WE	WE20-DSR07-WE	WE20-DTD03-WE-A	WE20-DMD03-WE-A
5"	1022	WE20-EHD00-WE	WE20-EDA06-WE	WE20-ESR08-WE	WE20-ETD04-WE-A	WE20-EMD04-WE-A
6"	1579	WE20-FHD00-WE	WE20-FDA07-WE	WE20-FSR09-WE	WE20-FTD04-WE-A	WE20-FMD04-WE-A
8"	3136	WE20-GHD00-WE	WE20-GDA08-WE	WE20-GSR10-WE	WE20-GTD05-WE-A	WE20-GMD05-WE-A
10"	5340	WE20-HHD00-WE	WE20-HDA09-WE	WE20-HSR11-WE	WE20-HTD06-WE-A	WE20-HMD06-WE-A
12"	8250	WE20-IHD00-WE	WE20-IDA11-WE	WE20-ISR11-WE	WE20-ITD07-WE-A	WE20-IMD07-WE-A

MODEL CHART - HAND OPERATED & PNEUMATIC ACTUATOR							
Example	WE20	-BSR04	-WE	-A	A	00	
Series	WE20						Butterfly valve
Size and Actuator		AHD00 BHD00 CHD00 DHD00 EHD00 FHD00 GHD00 HHD00 IHD00 ADA03 BDA03 CDA04 DDA05 EDA06 FDA07 GDA08 HDA09 IDA11 ASR04 BSR04 CSR06 DSR07 ESR08 FSR09 GSR10 HSR11 ISR11					2" hand operated 2-1/2" hand operated 3" hand operated 4" hand operated 5" hand operated 6" hand operated 8" hand operated 10" hand operated 12" hand operated 2" double acting 2-1/2" double acting 3" double acting 4" double acting 5" double acting 6" double acting 8" double acting 10" double acting 12" double acting 2" spring return 2-1/2" spring return 3" spring return 4" spring return 5" spring return 6" spring return 8" spring return 10" spring return 12" spring return
Body Type /Liner			WE WP LE LP				Wafer-EPDM Wafer-PTFE Lug-EPDM Lug-PTFE
Solenoid				N A			No solenoid NEMA 4X NAMUR solenoid
Solenoid Voltage					N A B C D E		No solenoid 120 VAC 220 VAC 24 VAC 24 VDC 12 VDC
Positioner and Switches						00 01 02 03 04 06 07 08 09	None 42AD0 exp limit switch 45VD0 exp position transmitter 42AD0-B ATEX limit switch 42AD0-IE IECEx limit switch QV-210101 poly limit switch VPS and P1 prox switch 265ER-D5 positioner 285ER-D5 smart positioner
Options						NO	Fail open spring return actuator

MODEL CHART - ELECTRIC ACTUATOR					
Example	WE20	-DMH05	-WE	-A	
Series	WE20				Butterfly valve
Size and Actuator		ATD02 BTD02 CTD02 DTD03 ETD04 FTD04 GTD05 HTD06 ITD07 AMD02 BMD02 CMD02 DMD03 EMD04 FMD04 GMD05 HMD06 IMD07 ATH03 BTH03 CTH05 DTH05 ETH06 FTH08 GTH09 HTH10 ITH11 AMH03 BMH03 CMH05 DMH05 EMH06 FMH08 GMH09 HMH10 IMH11			2" NEMA 4X two-position 2-1/2" NEMA 4X two-position 3" NEMA 4X two-position 4" NEMA 4X two-position 5" NEMA 4X two-position 6" NEMA 4X two-position 8" NEMA 4X two-position 10" NEMA 4X two-position 12" NEMA 4X two-position 2" NEMA 4X modulating 2-1/2" NEMA 4X modulating 3" NEMA 4X modulating 4" NEMA 4X modulating 5" NEMA 4X modulating 6" NEMA 4X modulating 8" NEMA 4X modulating 10" NEMA 4X modulating 12" NEMA 4X modulating 2" exp two-position 2-1/2" exp two-position 3" exp two-position 4" exp two-position 5" exp two-position 6" exp two-position 8" exp two-position 10" exp two-position 12" exp two-position 2" exp electric modulating 2-1/2" exp electric modulating 3" exp electric modulating 4" exp electric modulating 5" exp electric modulating 6" exp electric modulating 8" exp electric modulating 10" exp electric modulating 12" exp electric modulating
Material/Liner			WE WP LE LP		Wafer-EPDM Wafer-PTFE Lug-EPDM Lug-PTFE
Actuator Voltage				A B C D	110 VAC 220 VAC 24 VAC 24 VDC

ACCESSORIES	
Model	Description
AFR4	Air filter regulator 0 to 120 psi
VB-01	Volume booster

# PNEUMATIC AND ELECTRIC ACTUATORS

## Actuators for Valve and Damper Automation



ACT-SR03



ACT-TD01-110VAC



ACT-MI02-110VAC

The W.E. Anderson **Series ACT Actuators** are available in either pneumatic or electric models. The wide range of torques and voltages means there is an actuator for almost any application. The standard ISO 5211 mounting configuration makes installation to any valve or damper quick and simple.

W.E. Anderson pneumatic ACT models are a compact rack-and-pinion design with a symmetrical structure that ensures fast and steady action, high precision and high output power. The corrosion resistant anodized aluminum body is designed to withstand the harsh and abusive industrial environments and provide reliable service. We offer double acting and spring return models in a variety of sizes to fit any application.

W.E. Anderson electric ACT models are available in two-position or modulating configurations and NEMA 4X or NEMA 7 rated enclosures. All electric actuators utilize a high grade powder coated aluminum enclosure with visual indicators. The two-position models come standard with two auxiliary switches, and modulating models offer an output for position monitoring. Certain models are equipped with manual overrides allowing the operator to cycle the valve manually for installation or maintenance checks.

### FEATURES/BENEFITS

- ISO 5211 Mounting configuration for easy installation
- Pneumatic actuators offer corrosion resistance anodized finish
- NAMUR mounting configuration on pneumatic actuators
- Two-position electric actuators include auxiliary limit switches
- Modulating electric actuators offer an output for position monitoring

### APPLICATIONS

- Designed for quarter turn valve or damper control

### SPECIFICATIONS

#### Pneumatic "DA" and "SR" Series

**Type:** DA series is double-acting and SR series is spring return (rack and pinion).

**Normal Supply Pressure:** DA: 40 to 115 psi (2.7 to 7.9 bar); SR: 80 psi (5.5 bar).

**Maximum Supply Pressure:** 120 psi (8.6 bar).

**Air Connections:** DA01: 1/8" female NPT; DA02 to DA14: 1/4" female NPT; SR02 to SR14: 1/4" female NPT.

**Housing Material:** Anodized aluminum body and epoxy coated aluminum end caps.

**Temperature Limits:** -40 to 176°F (-40 to 80°C).

**Accessory Mounting:** NAMUR standard.

#### Electric "TD" and "MD" Series

**Power Requirements:** 110 VAC, 220 VAC, 24 VAC or 24 VDC (MD models not available in 24 VDC).

**Power Consumption:** See manual.

**Cycle Time (per 90°):** TD01: 4 s; MD01: 10 s; TD02 and MD02: 20 s; TD03 and MD03: 30 s; TD04 and MD04: 30 s; TD05 and MD05: 30 s; TD06 and MD06: 45 s; TD07 and MD07: 45 s.

**Duty Rating:** 85%.

**Enclosure Rating:** NEMA 4X (IP67).

**Housing Material:** Powder coated aluminum.

**Temperature Limits:** -22 to 140°F (-30 to 60°C).

**Electrical Connection:** 1/2" female NPT.

**Modulating Input:** 4-20 mA.

**Standard Features:** Manual override, position indicator, and TD models come with two limit switches.

#### Electric "TI" and "MI" Series

**Power Requirements:** 110 VAC, 220 VAC, 24 VAC or 24 VDC.

**Power Consumption:** See instruction manual.

**Cycle Time (per 90°):** See instruction manual.

**Duty Rating:** See instruction manual.

**Enclosure Rating:** NEMA 7.

**Housing Material:** Powder coated aluminum.

**Temperature Limits:** -40 to 140°F (-40 to 60°C).

**Electrical Connection:** 1/2" female NPT.

**Modulating Input:** 4-20 mA.

**Standard Features:** Position indicator and two limit switches.

### MODEL CHART

Pneumatic Model	Description	Electric Model	Description
ACT-DA01	Double acting pneumatic actuator, 98 in-lb	ACT-TD01-110VAC	Electric two-position, 177 in-lb, 110 VAC
ACT-DA02	Double acting pneumatic actuator, 207 in-lb	ACT-TD02-110VAC	Electric two-position, 442 in-lb, 110 VAC
ACT-DA03	Double acting pneumatic actuator, 365 in-lb	ACT-TD03-110VAC	Electric two-position, 885 in-lb, 110 VAC
ACT-DA04	Double acting pneumatic actuator, 603 in-lb	ACT-TD04-110VAC	Electric two-position, 1770 in-lb, 110 VAC
ACT-DA05	Double acting pneumatic actuator, 792 in-lb	ACT-TD05-110VAC	Electric two-position, 3540 in-lb, 110 VAC
ACT-DA06	Double acting pneumatic actuator, 1135 in-lb	ACT-TD06-110VAC	Electric two-position, 8850 in-lb, 110 VAC
ACT-DA07	Double acting pneumatic actuator, 1690 in-lb	ACT-MD01-110VAC	Electric modulating, 265 in-lb, 110 VAC
ACT-DA08	Double acting pneumatic actuator, 2993 in-lb	ACT-MD02-110VAC	Electric modulating, 442 in-lb, 110 VAC
ACT-DA09	Double acting pneumatic actuator, 4506 in-lb	ACT-MD03-110VAC	Electric modulating, 885 in-lb, 110 VAC
ACT-DA10	Double acting pneumatic actuator, 6866 in-lb	ACT-MD04-110VAC	Electric modulating, 1770 in-lb, 110 VAC
ACT-DA11	Double acting pneumatic actuator, 11065 in-lb	ACT-MD05-110VAC	Electric modulating, 3540 in-lb, 110 VAC
ACT-DA12	Double acting pneumatic actuator, 15207 in-lb	ACT-MD06-110VAC	Electric modulating, 8850 in-lb, 110 VAC
ACT-DA13	Double acting pneumatic actuator, 23834 in-lb	ACT-TI01-110VAC	EXP electric two-position, 100 in-lb, 110 VAC
ACT-DA14	Double acting pneumatic actuator, 33516 in-lb	ACT-TI02-110VAC	EXP electric two-position, 200 in-lb, 110 VAC
ACT-SR02	Spring return pneumatic actuator, 95 in-lb	ACT-TI03-110VAC	EXP electric two-position, 300 in-lb, 110 VAC
ACT-SR03	Spring return pneumatic actuator, 176 in-lb	ACT-TI04-110VAC	EXP electric two-position, 400 in-lb, 110 VAC
ACT-SR04	Spring return pneumatic actuator, 274 in-lb	ACT-TI05-110VAC	EXP electric two-position, 675 in-lb, 110 VAC
ACT-SR05	Spring return pneumatic actuator, 381 in-lb	ACT-TI06-110VAC	EXP electric two-position, 1000 in-lb, 110 VAC
ACT-SR06	Spring return pneumatic actuator, 536 in-lb	ACT-TI07-110VAC	EXP electric two-position, 1500 in-lb, 110 VAC
ACT-SR07	Spring return pneumatic actuator, 815 in-lb	ACT-TI08-110VAC	EXP electric two-position, 2000 in-lb, 110 VAC
ACT-SR08	Spring return pneumatic actuator, 1411 in-lb	ACT-TI09-110VAC	EXP electric two-position, 3840 in-lb, 110 VAC
ACT-SR09	Spring return pneumatic actuator, 2460 in-lb	ACT-TI10-110VAC	EXP electric two-position, 5000 in-lb, 110 VAC
ACT-SR10	Spring return pneumatic actuator, 3733 in-lb	ACT-TI11-110VAC	EXP electric two-position, 7020 in-lb, 110 VAC
ACT-SR11	Spring return pneumatic actuator, 6166 in-lb	ACT-MI01-110VAC	EXP electric modulating, 100 in-lb, 110 VAC
ACT-SR12	Spring return pneumatic actuator, 5253 in-lb	ACT-MI02-110VAC	EXP electric modulating, 200 in-lb, 110 VAC
ACT-SR13	Spring return pneumatic actuator, 7923 in-lb	ACT-MI03-110VAC	EXP electric modulating, 300 in-lb, 110 VAC
ACT-SR14	Spring return pneumatic actuator, 9546 in-lb	ACT-MI04-110VAC	EXP electric modulating, 400 in-lb, 110 VAC
		ACT-MI05-110VAC	EXP electric modulating, 675 in-lb, 110 VAC
		ACT-MI06-110VAC	EXP electric modulating, 1000 in-lb, 110 VAC
		ACT-MI07-110VAC	EXP electric modulating, 1500 in-lb, 110 VAC
		ACT-MI08-110VAC	EXP electric modulating, 2000 in-lb, 110 VAC
		ACT-MI09-110VAC	EXP electric modulating, 3840 in-lb, 110 VAC
		ACT-MI10-110VAC	EXP electric modulating, 5000 in-lb, 110 VAC
		ACT-MI11-110VAC	EXP electric modulating, 7020 in-lb, 110 VAC

**Note:** Optional voltages available for the electric actuators. Change the -110 VAC to -220 VAC, 24 VDC or 24 VAC. The ACT-MD is not available with 24 VAC.



# PNEUMATIC AND ELECTRIC ACTUATORS

Actuators for Valve and Damper Automation

MODEL CHART - DOUBLE ACTING ACTUATOR TORQUE										
Model	Double Acting Pneumatic Actuator Output Torque (in-lb)									
	Air Pressure									
	40 psi	50 psi	60 psi	70 psi	80 psi	90 psi	100 psi	110 psi	115 psi	
ACT-DA01	49	61	74	86	98	110	123	135	142	
ACT-DA02	104	130	155	181	207	233	259	285	300	
ACT-DA03	182	228	274	319	365	411	456	502	529	
ACT-DA04	302	377	453	528	603	679	754	830	875	
ACT-DA05	396	495	594	693	792	891	990	1089	1148	
ACT-DA06	567	709	851	993	1135	1277	1419	1561	1646	
ACT-DA07	845	1056	1267	1478	1690	1901	2112	2323	2450	
ACT-DA08	1497	1871	2245	2619	2993	3367	3742	4116	4340	
ACT-DA09	2253	2816	3379	3942	4506	5069	5632	6195	6533	
ACT-DA10	3433	4291	5149	6008	6866	7724	8582	9440	9955	
ACT-DA11	5532	6916	8299	9682	11065	12448	13831	15214	16044	
ACT-DA12	7603	9504	11405	13306	15207	17107	19008	20909	22050	
ACT-DA13	11917	14896	17875	20855	23834	26813	29792	32772	34559	
ACT-DA14	16758	20948	25137	29327	33516	37706	41896	46085	48599	

ACCESSORIES	
Models	Description
AFR4	Air filter regulator 0 to 120 psi
VB-01	Volume booster
SN-5A	5/2 NAMUR 110 VAC solenoid
SN-3A	3/2 NAMUR 110 VAC solenoid

MODEL CHART - SPRING RETURN ACTUATOR TORQUE															
Model	Spring Sets	Torque List of Spring Return Pneumatic Actuator (in-lb)													
		Spring Torque		Air Pressure											
		0°	90°	70 psi		80 psi		90 psi		100 psi		110 psi		115 psi	
ACT-SR02	10	69.9	95.5	111.4	85.8	137.3	111.7	163.2	137.6	189.1	163.5	215	189.4	230.6	204.9
ACT-SR03	10	120	176	199	143	245	189	291	235	336	280	382	326	409	353
ACT-SR04	10	180	274	348	254	424	330	499	405	575	481	650	556	695	601
ACT-SR05	10	263	381	430	312	529	411	628	510	727	609	826	708	885	767
ACT-SR06	10	385	536	608	458	750	599	891	741	1033	883	1175	1025	1260	1110
ACT-SR07	10	695	815	783	663	994	874	1206	1085	1417	1297	1628	1508	1755	1635
ACT-SR08	10	937	1411	1682	1208	2056	1583	2430	1957	2804	2331	3178	2705	3403	2930
ACT-SR09	10	1640	2460	2303	1483	2866	2046	3429	2609	3992	3173	4556	3736	4894	4074
ACT-SR10	10	2529	3733	3479	2274	4337	3133	5195	3991	6053	4849	6911	5707	7426	6222
ACT-SR11	10	4104	6166	5578	3516	6961	4899	8344	6282	9727	7665	11111	9048	11940	9878
ACT-SR12	10	5253	8258	8052	5048	9953	6948	11854	8849	13755	10750	15656	12651	16796	13791
ACT-SR13	10	7923	14103	12932	6752	15911	9731	18890	12710	21869	15690	24849	18669	26636	20456
ACT-SR14	10	9546	18350	19781	10977	23970	15167	28160	19357	32349	23546	36539	27736	39053	30249

SERIES ARK

## PNEUMATIC ACTUATOR REPAIR KIT

Springs, Gaskets, and O-rings for Series ACT-DA/SR



ARK-14

The Series ARK Pneumatic Actuator Repair Kit includes a complete set of O-rings for the Series ACT-DA and ACT-SR pneumatic actuators.

FEATURES/BENEFITS

- Kit includes springs, gaskets and O-rings for ACT-DA/SR

APPLICATIONS

- Repair kit for ACT-DA or ACT-SR actuators

MODEL CHART			
Model	Dwyer Actuator (Model)	Model	Dwyer Actuator (Model)
ARK-00	ACT-DA01	ARK-14	ACT-SR02
ARK-01	ACT-DA02	ARK-15	ACT-SR03
ARK-02	ACT-DA03	ARK-16	ACT-SR04
ARK-03	ACT-DA04	ARK-17	ACT-SR05
ARK-04	ACT-DA05	ARK-18	ACT-SR06
ARK-05	ACT-DA06	ARK-19	ACT-SR07
ARK-06	ACT-DA07	ARK-20	ACT-SR08
ARK-07	ACT-DA08	ARK-21	ACT-SR09
ARK-08	ACT-DA09	ARK-22	ACT-SR10
ARK-09	ACT-DA10	ARK-23	ACT-SR11
ARK-10	ACT-DA11	ARK-24	ACT-SR12

SPECIFICATIONS

Agency Approvals: Meets the technical requirements of EU Directive 2011/65/EU (RoHS II).

ACTUATOR REPAIR KIT FOR:



Series ACT-SR/DA

PARTS LIST - INCLUDED IN KIT

- (2) FVMQ O-rings for end caps
- (2) FVMQ O-rings for piston
- (2) FVMQ O-rings for stem
- (2) FVMQ O-rings for adjusting bolt
- (10) Stainless steel springs (ACT-SR kits only)

**Dwyer**

SERIES 38R | W.E. ANDERSON™ BY DWYER

# SELF-ACTING TEMPERATURE CONTROL VALVE

Requires No External Power



The **Series 38R Self-Acting Temperature Control Valve** requires no external power sources and is ideal for regulating the temperature of tanks, process streams and various types of industrial equipment. The actuators are made with a rugged die-cast aluminum housing with a fully enclosed bellow assembly and internal over-range protection. Valves are offered in 1/2" through 6" connection sizes and 1/8" through 6" port sizes. The valve bodies are available in single-seated direct or reverse-acting, double-seated direct or reverse-acting, and 3-way designs with four choices of body material: bronze, cast-iron, cast-steel, and 316 SS. Actuators are available with or without indicating dials or in Fail-Safe. Non-indicating actuators feature a lower profile and should be implemented where space constraints may be an issue while the indicating actuator allows the operator to verify the process temperature and aid in temperature adjustment. Fail-Safe actuators are designed to cause the valve to fail in the safe control position (open in cooling application, closed in a heating application) should some accidental damage occur to the terminal system, resulting in loss of pressure charge. Also available with the Series 38R are a wide range of capillaries, bulbs, and thermowells.

Please request a copy of our Valve Catalog, CT-VC, or visit our website at [www.dwyer-inst.com](http://www.dwyer-inst.com) to see full model information and ordering details for the Series 38R.

## FEATURES/BENEFITS

- Self-operated design
- Internal over range protection
- Heavy duty die cast aluminum actuator

## APPLICATIONS

- Temperature control without external power or control inputs

## SPECIFICATIONS

### VALVE BODY

**Service:** Compatible liquids, gases, and steam.

**Line Size:** 1/2" to 2".

**Body Style:** 2-way or 3-way.

**End Connections:** 1/2" to 2" female NPT.

**Pressure Limit:** 250 psi (17.2 bar).

**Wetted Materials:** Body material: Bronze or 316 SS; Trim: 316 SS; Packing: PTFE.

**Temperature Limits:** 410°F (210°C) @ 250 psi (17.24 bar).

### ACTUATOR

**Power Requirements:** Fully self-contained, no external power required.

**Indicator:** 3-1/2" dial thermometer, SS case, swivel and angle adjustable (available for indicating actuator only).

**Housing:** Die cast aluminum, epoxy powder coated blue finish.

**Set Point Scale:** Integral to housing.

**Bellows:** High-pressure brass, corrosion resistant, tinplated finish.

**Adjustment Screws:** Brass.

**Range Adjustment Spring:** Cadmium plated.

**Overrange Protection:** 100°F over upper range limit for temporary situations.

**Note:** See website for additional options.



SERIES 38R | W.E. ANDERSON™ BY DWYER

# SELF-ACTING TEMPERATURE CONTROL VALVE

Requires No External Power

MODEL CHART									
Example	38R	-D00VA32	-1	01	36	2	-R09	38R-D00VA32-101362-R09	
Series	38R							Self-acting temperature control valve	
Valve		D00VA32 D01VA32 D02VA32 D03VA32 D04VA32 D05VA32 R00VA32 R01VA32 R02VA32 R03VA32 R04VA32 R05VA32 D00VA42 D01VA42 D02VA42 D03VA42 D04VA42 D05VA42 R00VA42 R01VA42 R02VA42 R03VA42 R04VA42 R05VA42 300WA31 301WA31 302WA31 303WA31 304WA31 305WA31 300WA41 301WA41 302WA41 303WA41 304WA41 305WA41							1/2" NPT single seat two-way bronze valve, direct acting 3/4" NPT single seat two-way bronze valve, direct acting 1" NPT single seat two-way bronze valve, direct acting 1-1/4" NPT single seat two-way bronze valve, direct acting 1-1/2" NPT single seat two-way bronze valve, direct acting 2" NPT single seat two-way bronze valve, direct acting 1/2" NPT single seat two-way bronze valve, reverse acting 3/4" NPT single seat two-way bronze valve, reverse acting 1" NPT single seat two-way bronze valve, reverse acting 1-1/4" NPT single seat two-way bronze valve, reverse acting 1-1/2" NPT single seat two-way bronze valve, reverse acting 2" NPT single seat two-way bronze valve, reverse acting 1/2" NPT single seat two-way 316 SS valve, direct acting 3/4" NPT single seat two-way 316 SS valve, direct acting 1" NPT single seat two-way 316 SS valve, direct acting 1-1/4" NPT single seat two-way 316 SS valve, direct acting 1-1/2" NPT single seat two-way 316 SS valve, direct acting 2" NPT single seat two-way 316 SS valve, direct acting 1/2" NPT single seat two-way 316 SS valve, reverse acting 3/4" NPT single seat two-way 316 SS valve, reverse acting 1" NPT single seat two-way 316 SS valve, reverse acting 1-1/4" NPT single seat two-way 316 SS valve, reverse acting 1-1/2" NPT single seat two-way 316 SS valve, reverse acting 2" NPT single seat two-way 316 SS valve, reverse acting 1/2" NPT three-way bronze valve 3/4" NPT three-way bronze valve 1" NPT three-way bronze valve 1-1/4" NPT three-way bronze valve 1-1/2" NPT three-way bronze valve 2" NPT three-way bronze valve 1/2" NPT three-way 316 SS valve 3/4" NPT three-way 316 SS valve 1" NPT three-way 316 SS valve 1-1/4" NPT three-way 316 SS valve 1-1/2" NPT three-way 316 SS valve 2" NPT three-way 316 SS valve
Actuator			1 2					Non-indicating actuator Indicating actuator	
Bulb and Capillary				01 02 03 04 05 06 07 08 09 10				Brass union connection 316 SS union connection Brass adjustable union connection 316 SS adjustable union connection Brass plain bulb 316 SS plain bulb FEP Covered brass bulb FEP Covered 316 SS bulb Brass union with stainless steel spiral armor 316 SS union with stainless steel spiral armor	
Capillary Length					36			Capillary length in feet. Example 36 is 36' length	
Thermowell						0 1 2		No thermowell 316 SS thermowell, 1-1/4" external connection Brass thermowell, 1-1/4" external connection	
Temperature Range							R03 R04 R05 R06 R07 R09 R10 R11 R12 R13 R14	30 to 115°F (-1 to 46°C) 50 to 140°F (10 to 60°C) 75 to 165°F (24 to 74°C) 105 to 195°F (41 to 91°C) 125 to 215°F (52 to 102°C) 155 to 250°F (68 to 121°C) 200 to 280°F (93 to 138°C) 225 to 315°F (107 to 157°C) 255 to 370°F (124 to 188°C) 295 to 420°F (146 to 216°C) 310 to 440°F (154 to 227°C)	

USA: California Proposition 65  
 ⚠ WARNING: Cancer and Reproductive Harm - www.P65Warnings.ca.gov

# HI-FLOW™ CONTROL VALVES

Globe Valves, Ideal for Steam and Water Flow Control, 1/2" to 2-1/2" Sizes, 2-Way or 3-Way



2-way with positioner



2-way with air-to-close actuator



2-way with air-to-open actuator

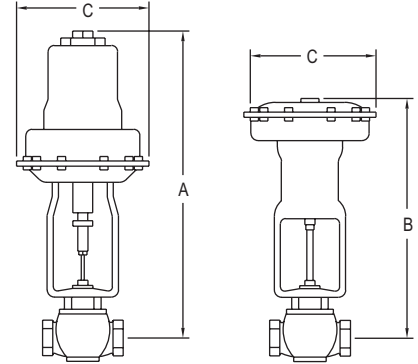

**Hi-Flow™ Control Valves** are single seated, top or cage guided globe valves - probably the simplest, from a construction standpoint, yet most versatile control valve in use. The Hi-Flow™ valve can fit applications with a smaller size valve since the valve has a greater flow capacity than most conventional valves of the same size. Coupled with the high flow capacity, the Hi-Flow™ valve maintains a wide rangeability of 50:1 to insure precise control. Heavy duty Hi-Flow™ valves are ruggedly constructed of the highest quality materials, precision machined, and performance tested to assure years of trouble free service. Standard packing consists of PTFE V-rings and wiper to minimize friction without leakage at high operating pressures. Available in brass, iron, or 316 SS body, trim is 316 SS with all welded plug construction to provide superior durability and corrosion resistance.

#### FEATURES/BENEFITS

- Wide rangeability of 50:1
- Exceptional shut-off and leak rate that meets ANSI/FCI 70-2 Class IV (0.01% of Cv in the closed position)
- Selectable fail safe condition with Air-to-Raise or Air-to-Lower actuators and Push-to-Open or Push-to-Close valve bodies
- Linear or equal percentage flow characteristics
- Low flow options of restricted trim or needle plug
- Removable and replaceable seat ring

#### APPLICATIONS

- Flow control, mixing, or diverting service
- Perfect for steam, water or compatible glycol solutions

#### HOW TO ORDER

Select model number from model chart or standard product chart and supply maximum upstream pressure, USP.

#### SPECIFICATIONS

##### VALVE BODY

**Service:** Compatible liquids, gases, and steam.

**Line Size:** 1/2" to 2".

**Body Style:** 2-way or 3-way globe.

**End Connections:** 1/2" to 2" female NPT.

**Pressure Limit:** Iron and bronze body: 250 psi (17.2 bar); 316 SS body: 300 psi (20.7 bar).

**Wetted Materials:** Body material: Iron, bronze, or 316 SS; Trim: 316 SS.

**Packing:** PTFE.

**Temperature Limits:** 20 to 400°F (-7 to 204.4°C).

##### ACTUATOR

**Type:** Pneumatic spring/diaphragm.

**Control Signal:** 3 to 15 psi (0.21 to 1.0 bar) standard. Custom ranges available.

**Maximum Supply Pressure:** 220, 222, and 230: 100 psi (6.89 bar). 221, 223, 231, and 233: 50 psi (3.45 bar).

**Air Connection:** 1/4" female NPT.

**Temperature Limit:** 150°F (66°C).

**Note:** Positioners and current-to-pressure transducers available factory mounted.



**Caution:** Use of an actuator supply gas other than air can create a hazardous environment because a small amount of gas continuously vents to atmosphere.

USA: California Proposition 65

⚠ WARNING: Cancer and Reproductive Harm - [www.P65Warnings.ca.gov](http://www.P65Warnings.ca.gov)

● Transducers: See page 442 (Series 2800)

● Positioners: See page 444 (Series 165)

See page 443 (Series 2900)



# HI-FLOW™ CONTROL VALVES

Globe Valves, Ideal for Steam and Water Flow Control, 1/2" to 2-1/2" Sizes, 2-Way or 3-Way

Use the chart below to aid in the selection of Hi-Flow™ Control Valve. As long as the maximum upstream pressure (USP) is less than, or equal to, the value listed, the model shown can be manufactured and calibrated to your specific requirements. Specify maximum upstream pressure, USP, when ordering.

MODEL CHART - 2-WAY SIMPLIFIED SELECTION GUIDE WITH STANDARD PRODUCTS										
Pipe Size	Cv 100%	Body Material	Air-To-Open Model	Max USP psi [bar] 3-15 [.21-1.0]	A in [mm]	C in [mm]	Air-To-Close Model	Max USP psi [bar] 3-15 [.21-1.0]	B in [mm]	C in [mm]
1/2"	6.45	Bronze	2000VA32-230	250 [17.2]	19-3/4 [501.7]	7-3/4 [196.9]	2000VA32-220	250 [17.2]	18-7/16 [468.3]	7-3/4 [196.9]
1/2"	6.45	316 SS	2000VA42-230	300 [20.7]	19-3/4 [501.7]	7-3/4 [196.9]	2000VA42-220	300 [20.7]	18-7/16 [468.3]	7-3/4 [196.9]
3/4"	10.75	Bronze	2001VA32-230	250 [17.2]	19-3/4 [501.7]	7-3/4 [196.9]	2001VA32-220	250 [17.2]	18-7/16 [468.3]	7-3/4 [196.9]
3/4"	10.75	Bronze	2001VA32-231	250 [17.2]	20-3/8 [517.5]	10-5/8 [269.9]	2001VA32-221	250 [17.2]	19-1/8 [485.8]	10-5/8 [269.9]
3/4"	10.75	316 SS	2001VA42-230	285 [19.7]	19-3/4 [501.7]	7-3/4 [196.9]	2001VA42-220	300 [20.7]	18-7/16 [468.3]	7-3/4 [196.9]
3/4"	10.75	316 SS	2001VA42-231	300 [20.7]	20-3/8 [517.5]	10-5/8 [269.9]	2001VA42-221	300 [20.7]	19-1/8 [485.8]	10-5/8 [269.9]
1"	17.42	Bronze	2002VA32-230	166 [11.4]	20-3/16 [512.8]	7-3/4 [196.9]	2002VA32-220	192 [13.2]	18-7/8 [479.4]	7-3/4 [196.9]
1"	17.42	Bronze	2002VA32-231	250 [17.2]	20-13/16 [528.6]	10-5/8 [269.9]	2002VA32-221	250 [17.2]	19-9/16 [496.9]	10-5/8 [269.9]
1"	17.42	316 SS	2002VA42-230	166 [11.4]	20-3/16 [512.8]	7-3/4 [196.9]	2002VA42-220	192 [13.2]	18-7/8 [479.4]	7-3/4 [196.9]
1"	17.42	316 SS	2002VA42-231	300 [20.7]	20-13/16 [528.6]	10-5/8 [269.9]	2002VA42-221	300 [20.7]	19-9/16 [496.9]	10-5/8 [269.9]
1-1/4"	25.30	Bronze	2003VA32-230	98 [6.8]	20-5/16 [515.9]	7-3/4 [196.9]	2003VA32-220	115 [7.9]	19 [482.6]	7-3/4 [196.9]
1-1/4"	25.30	Bronze	2003VA32-231	245 [16.9]	20-15/16 [531.8]	10-5/8 [269.9]	2003VA32-221	250 [17.2]	19-11/16 [500.1]	10-5/8 [269.9]
1-1/4"	25.30	Bronze	2003VA32-233	250 [17.2]	25-13/32 [645.3]	13-3/8 [339.7]	2003VA32-223	250 [17.2]	23-1/8 [587.4]	13-3/8 [339.7]
1-1/4"	25.30	316 SS	2003VA42-230	98 [6.8]	20-5/16 [515.9]	7-3/4 [196.9]	2003VA42-220	115 [7.9]	19 [482.6]	7-3/4 [196.9]
1-1/4"	25.30	316 SS	2003VA42-231	245 [17.0]	20-15/16 [531.8]	10-5/8 [269.9]	2003VA42-221	300 [20.7]	19-11/16 [500.1]	10-5/8 [269.9]
1-1/4"	25.30	316 SS	2003VA42-233	300 [20.7]	25-13/32 [645.3]	13-3/8 [339.7]	2003VA42-223	300 [20.7]	23-1/8 [587.4]	13-3/8 [339.7]
1-1/2"	32.10	Bronze	2004VA32-230	65 [4.5]	20-11/16 [525.5]	7-3/4 [196.9]	2004VA32-220	80 [5.5]	19-3/8 [492.1]	7-3/4 [196.9]
1-1/2"	32.10	Bronze	2004VA32-231	168 [11.6]	21-5/16 [541.3]	10-5/8 [269.9]	2004VA32-221	235 [16.2]	20-1/16 [509.6]	10-5/8 [269.9]
1-1/2"	32.10	Bronze	2004VA32-233	250 [17.2]	25-25/32 [654.8]	13-3/8 [339.7]	2004VA32-223	250 [17.2]	23-1/2 [596.9]	13-3/8 [339.7]
1-1/2"	32.10	316 SS	2004VA42-230	65 [4.5]	20-11/16 [525.5]	7-3/4 [196.9]	2004VA42-220	80 [5.5]	19-3/8 [492.1]	7-3/4 [196.9]
1-1/2"	32.10	316 SS	2004VA42-231	168 [11.6]	21-5/16 [541.3]	10-5/8 [269.9]	2004VA42-221	235 [16.2]	20-1/16 [509.6]	10-5/8 [269.9]
1-1/2"	32.10	316 SS	2004VA42-233	300 [20.7]	25-25/32 [654.8]	13-3/8 [339.7]	2004VA42-223	300 [20.7]	23-1/2 [596.9]	13-3/8 [339.7]
2"	50.30	Bronze	2005VA32-230	31 [2.1]	20-15/16 [531.8]	7-3/4 [196.9]	2005VA32-220	44 [3.0]	19-5/8 [498.5]	7-3/4 [196.9]
2"	50.30	Bronze	2005VA32-231	88 [6.1]	21-9/16 [547.7]	10-5/8 [269.9]	2005VA32-221	140 [9.7]	20-5/16 [515.9]	10-5/8 [269.9]
2"	50.30	Bronze	2005VA32-233	175 [12.1]	26-1/32 [661.2]	13-3/8 [339.7]	2005VA32-223	250 [17.2]	23-3/4 [603.3]	13-3/8 [339.7]
2"	50.30	316 SS	2005VA42-230	31 [2.1]	20-15/16 [531.8]	7-3/4 [196.9]	2005VA42-220	44 [3.0]	19-5/8 [498.5]	7-3/4 [196.9]
2"	50.30	316 SS	2005VA42-231	88 [6.1]	21-9/16 [547.7]	10-5/8 [269.9]	2005VA42-221	140 [9.7]	20-5/16 [515.9]	10-5/8 [269.9]
2"	50.30	316 SS	2005VA42-233	175 [12.1]	26-1/32 [661.2]	13-3/8 [339.7]	2005VA42-223	272 [18.8]	23-3/4 [606.3]	13-3/8 [339.7]

MODEL CHART - CONTROL VALVES - HI-FLOW™ SERIES, 2-WAY, STOCKED MODELS					
Pipe Size	Cv 100%	Body Material	Air-To-Open Model	Set at USP psig [bar]	Adjustable USP Range psig [bar]
1/2"	6.45	Bronze	2000VA32-230-QS	125 [8.6]	96-200 [6.8-13.8]
3/4"	10.75	Bronze	2001VA32-230-QS	125 [8.6]	81-155 [5.6-10.7]
1"	17.42	Bronze	2002VA32-230-QS	125 [8.6]	123-166 [8.5-11.5]
1"	17.42	Bronze	2002VA32-231-QS	125 [8.6]	71-155 [4.9-10.7]
1-1/4"	25.30	Bronze	2003VA32-230-QS	98 [6.8]	66-98 [4.6-6.8]
1-1/4"	25.30	Bronze	2003VA32-231-QS	125 [8.6]	121-165 [8.3-11.4]
1-1/2"	32.10	Bronze	2004VA32-231-QS	125 [8.6]	104-137 [7.2-9.5]
2"	50.30	Bronze	2005VA32-231-QS	88 [6.1]	68-88 [4.7-6.1]
2"	50.30	Bronze	2005VA32-233-QS	125 [8.6]	116-145 [8.0-10.0]

USA: California Proposition 65  
 ⚠ WARNING: Cancer and Reproductive Harm - www.P65Warnings.ca.gov

Filters and Regulators: See pages 447-448

# HI-FLOW™ CONTROL VALVE

## 3-Way Standard Products for Mixing or Diverting

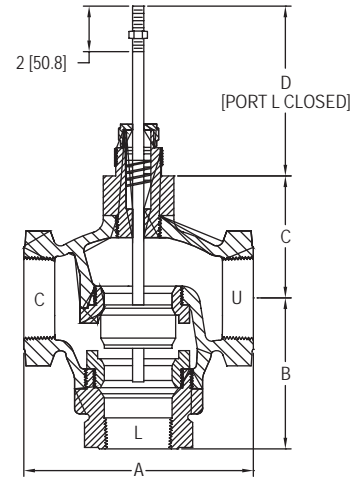
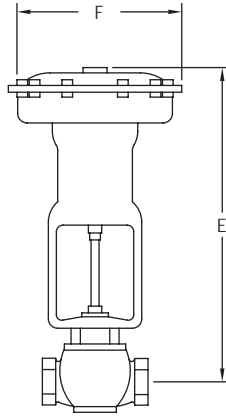

DIMENSIONS			
Pipe Size	B in [mm]	C in [mm]	D in [mm]
1/2"	2-9/16 [65.1]	2-3/16 [55.6]	4-1/8 [104.8]
3/4"	2-9/16 [65.1]	2-3/16 [55.6]	4-1/8 [104.8]
1"	3 [76.2]	2-7/16 [61.9]	4 [101.6]
1-1/4"	3-3/16 [81.0]	2-1/2 [63.5]	3-3/4 [95.3]
1-1/2"	3-3/4 [95.3]	2-3/4 [69.9]	3-11/16 [93.7]
2"	3-15/16 [100.0]	3-3/16 [81.0]	3-11/16 [93.7]

Use the standard models chart to aid in the selection of the most economical Hi-Flow™ 3-Way Control Valve for your application. Standard models include: LIN-E-AIRE® Air-To-Lower Actuator (port L opens on loss of air)

### Mixing Service

FLOW IN - ports U&L; FLOW OUT - port C

Specify maximum upstream pressures [USP's]: USP<sub>U</sub> and USP<sub>L</sub>

To determine shutoff pressure: (USP<sub>U</sub> - USP<sub>C</sub>) + (USP<sub>L</sub> - USP<sub>C</sub>)

### Diverting Service

FLOW IN - port C; FLOW OUT - ports U&L

Specify maximum upstream pressures [USP's]: USP<sub>C</sub>; based on standard 3-15 psi [.21-1.0 bar] pneumatic control signal

To determine shutoff pressure: USP<sub>U</sub> + USP<sub>C</sub>

### MODEL CHART - HI-FLOW™ CONTROL VALVES, 3-WAY SIMPLIFIED SELECTION GUIDE WITH STANDARD PRODUCTS

Pipe Size	Cv 100%	Body Material	Model	USP [S] psi [bar]	E in [mm]	F in [mm]
1/2"	6.45	Bronze	3000WA32-220	250 [17.2]	18-1/16 [458.8]	7-3/4 [196.9]
1/2"	6.45	316 SS	3000WA42-220	300 [20.7]	18-1/16 [458.8]	7-3/4 [196.9]
3/4"	10.75	Bronze	3001WA32-220	250 [17.2]	18-1/16 [458.8]	7-3/4 [196.9]
3/4"	10.75	316 SS	3001WA42-220	300 [20.7]	18-1/16 [458.8]	7-3/4 [196.9]
1"	17.42	Bronze	3002WA32-220	200 [13.8]	18-5/16 [465.1]	7-3/4 [196.9]
1"	17.42	Bronze	3002WA32-221	250 [17.2]	19 [482.6]	10-5/8 [269.9]
1"	17.42	316 SS	3002WA42-220	200 [13.8]	18-5/16 [465.1]	7-3/4 [196.9]
1"	17.42	316 SS	3002WA42-221	300 [20.7]	19 [482.6]	10-5/8 [269.9]
1-1/4"	25.30	Bronze	3003WA32-220	120 [8.4]	18-3/8 [466.7]	7-3/4 [196.9]
1-1/4"	25.30	Bronze	3003WA32-221	250 [17.2]	19-1/16 [484.2]	10-5/8 [269.9]
1-1/4"	25.30	316 SS	3003WA42-220	120 [8.3]	18-3/8 [466.7]	7-3/4 [196.9]
1-1/4"	25.30	316 SS	3003WA42-221	300 [20.7]	19-1/16 [484.2]	10-5/8 [269.9]
1-1/2"	32.10	Bronze	3004WA32-220	80 [5.6]	18-5/8 [473.1]	7-3/4 [196.9]
1-1/2"	32.10	Bronze	3004WA32-221	200 [13.8]	19-5/16 [490.5]	10-5/8 [269.9]
1-1/2"	32.10	Bronze	3004WA32-223	250 [17.2]	21-3/8 [542.9]	13-3/8 [339.7]
1-1/2"	32.10	316 SS	3004WA42-220	80 [5.5]	18-5/8 [473.1]	7-3/4 [196.9]
1-1/2"	32.10	316 SS	3004WA42-221	200 [13.8]	19-5/16 [490.5]	10-5/8 [269.9]
1-1/2"	32.10	316 SS	3004WA42-223	300 [20.7]	21-3/8 [542.9]	13-3/8 [339.7]
2"	50.30	Bronze	3005WA32-220	45 [3.1]	19-1/16 [484.2]	7-3/4 [196.9]
2"	50.30	Bronze	3005WA32-221	100 [6.9]	19-3/4 [501.7]	10-5/8 [269.9]
2"	50.30	Bronze	3005WA32-223	175 [12.1]	21-13/16 [554.0]	13-3/8 [339.7]
2"	50.30	316 SS	3005WA42-220	45 [3.1]	19-1/16 [484.2]	7-3/4 [196.9]
2"	50.30	316 SS	3005WA42-221	100 [6.9]	19-3/4 [501.7]	10-5/8 [269.9]
2"	50.30	316 SS	3005WA42-223	175 [12.1]	21-12/16 [554.0]	13-3/8 [339.7]

**Caution:** Use of an actuator supply gas other than air can create a hazardous environment because a small amount of gas continuously vents to atmosphere.

USA: California Proposition 65

⚠ WARNING: Cancer and Reproductive Harm - www.P65Warnings.ca.gov

# ANGLE SEAT VALVES - BRONZE & STAINLESS STEEL NPT

Low Cost, Compact Design, For Use with Gases and Liquids



SAV-BT



SAV-ST

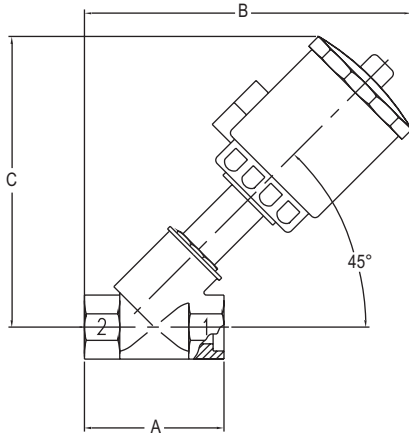

SERIES SAV-BT						
Port Connection	A	B	C	Actuator Diameter	NO Cv	NC Cv
1/2"	2.56"	6.42"	5.51"	2.76"	6.61	6.61
3/4"	2.95"	6.81"	5.79"	2.76"	12.18	12.18
1"	3.54"	8.11"	6.93"	3.32"	23.2	23.2
1-1/4"	4.33"	10.04"	8.66"	3.32"	33.06	33.64
1-1/2"	4.72"	10.63"	9.25"	4.58"	33.3	53.36
1-1/2"	4.72"	12.05"	10.67"	4.58"	-	53.94
2"	5.91"	11.02"	9.45"	4.58"	-	68.44
2"	5.91"	12.44"	10.87"	5.54"	53.94	77.72

SERIES SAV-ST						
Port Connection	A	B	C	Actuator Diameter	NO Cv	NC Cv
1/2"	3.35"	7.48"	6.14"	2.76"	6.61	6.61
3/4"	3.74"	7.68"	6.3"	2.76"	12.18	12.18
1"	4.13"	8.62"	7.17"	3.32"	23.2	23.2
1-1/4"	4.72"	10.47"	8.9"	3.32"	33.06	33.64
1-1/2"	5.12"	10.67"	9.06"	4.58"	33.3	53.36
1-1/2"	5.12"	12.09"	10.47"	4.58"	-	53.94
2"	5.91"	11.22"	9.45"	4.58"	-	68.44
2"	5.91"	12.64"	10.87"	5.54"	53.94	77.72

Save space while maintaining flow rates with the compact Series SAV-BT & SAV-ST Angle Seat Valves. The pneumatic, externally piloted angle seat valve is operated by a single acting actuator with a mechanical spring for failsafe operation. Select from either normally closed (NC) or normally open (NO) configurations. NO valves can be used to prevent waterhammer on valve closure in liquid applications.

**FEATURES/BENEFITS**

- Can be used in most gas, liquid and steam applications
- Integral heat sink protects Polyamide actuator
- Can be mounted in any position
- Actuator can be rotated 360° for positioning pressure ports

**APPLICATIONS**

- Gas or liquid flow control

**SPECIFICATIONS**

**VALVE BODY**

**Service:** Gases and liquids compatible with wetted materials.  
**Wetted Materials:** Valve body: SAV-BT: Bronze; SAV-ST: AISI 316L SS; Plug and stem: AISI 316L SS; Stem O-ring: Fluoroelastomers; Seat and seal: PTFE.  
**Line Sizes:** 1/2" to 2" NPT.  
**Pressure Limits:** See table.  
**Flow Leakage:** Meets ANSI Class VI.  
**Temperature Limits:** 14 to 358°F (-25 to 180°C).

**ACTUATOR**

**Type:** Piston/pneumatic spring.  
**Pilot Connections:** NAMUR solenoid mounting pad.  
**Pilot Media:** Air, water, inert gas.  
**Pressure Limits:** See table.  
**Temperature Limit:** 185°F (85°C).

MODEL CHART					
Port Connection	Actuator Diameter	Normally Closed Model	Normally Open Model	Normally Closed Model	Normally Open Model
1/2 NPT	2.76"	SAV-BTA1-NC	SAV-BTA2-NO	SAV-STA1-NC	SAV-STA2-NO
3/4 NPT	2.76"	SAV-BTB1-NC	SAV-BTB2-NO	SAV-STB1-NC	SAV-STB2-NO
1 NPT	3.32"	SAV-BTC1-NC	SAV-BTC3-NO	SAV-STC2-NC	SAV-STC3-NO
1-1/4 NPT	3.32"	SAV-BTD3-NC	SAV-BTD3-NO	SAV-STD3-NC	SAV-STD3-NO
1-1/2 NPT	4.58"	SAV-BTE2-NC	-	SAV-STE2-NC	-
1-1/2 NPT	5.54"	SAV-BTE3-NC	SAV-BTE3-NO	SAV-STE3-NC	SAV-STE3-NO
2 NPT	4.58"	SAV-BTF2-NC	-	SAV-STF2-NC	-
2 NPT	5.54"	SAV-BTF3-NC	SAV-BTF3-NO	SAV-STF3-NC	SAV-STF3-NO

LINE AND PILOT PRESSURE CHART (PSI)											
Port Connection	Actuator Diameter	Normally Closed					Normally Open				
		Max. Line Pressure	Max. Steam Pressure	Flow Direction	Min. Pilot Pressure	Max. Pilot Pressure	Max. Line Pressure	Max. Steam Pressure	Flow Direction	Min. Pilot Pressure	Max. Pilot Pressure
1/2 NPT	2.76"	230	150	Overseat	60	143	230	150	Underseat	60	143
3/4 NPT	2.76"	230	150	Overseat	60	143	230	150	Underseat	60	143
1 NPT	3.32"	290	150	Overseat	60	143	230	150	Underseat	60	143
1-1/4 NPT	3.32"	230	150	Overseat	60	114	230	150	Underseat	60	114
1-1/2 NPT	4.58"	230	150	Overseat	60	114	230	150	Underseat	60	114
1-1/2 NPT	5.54"	230	150	Overseat	60	114	230	150	Underseat	60	114
2 NPT	4.58"	143	150	Overseat	60	114	230	150	Underseat	60	114
2 NPT	5.54"	232	150	Overseat	60	114	230	150	Underseat	60	114

USA: California Proposition 65  
 ⚠ WARNING: Cancer and Reproductive Harm - www.P65Warnings.ca.gov



SERIES SBSV-B | W.E. ANDERSON™ BY DWYER



# BRASS SOLENOID VALVE, 2-WAY GUIDED NC

Compact Design, Immune to Mounting Orientation

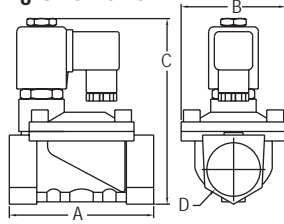

Model	A in [mm]	B in [mm]	C in [mm]	D NPT	Weight lb [kg]
SBSV-B1NX	1-5/8 [41]	1-5/32 [29]	3-9/32 [83]	1/8"	0.82 [0.37]
SBSV-B2NX	1-5/8 [41]	1-5/32 [29]	3-9/32 [83]	1/4"	0.79 [0.36]
SBSV-B3NX	2-5/8 [66]	1-57/64 [48]	4-7/16 [112]	3/8"	1.54 [0.7]
SBSV-B4NX	2-5/8 [66]	1-57/64 [48]	4-7/16 [112]	1/2"	1.98 [0.9]
SBSV-B5NX	2-61/64 [75]	2-19/64 [58]	4-21/32 [118]	3/4"	1.98 [0.9]
SBSV-B6NX	3-25/32 [96]	2-49/64 [70]	5-11/64 [131]	1"	3.09 [1.4]
SBSV-B7NX	5-11/64 [131]	3-25/32 [96]	3-3/4 [146]	1-1/4"	6.17 [2.8]
SBSV-B8NX	5-11/64 [131]	3-25/32 [96]	5-3/4 [146]	1-1/2"	5.95 [2.7]
SBSV-B9NX	6-1/2 [165]	4-47/64 [120]	6-37/64 [167]	2"	10.58 [4.8]

The Series SBSV-B Brass Solenoid Valve is compact, general-service, two-way guide type solenoid valves for air, gas, water and other liquid applications. They are available in brass with a normally closed design and can be oriented in any position. The solenoid enclosure provides protection against dust, while also protecting against seepage of oil and non-corrosive coolants. The Series SBSV-B valves come assembled with an NBR seal, having a maximum process temperature of 176°F (80°C). The series offers a wide range of valve sizes and flow ranges, with connection sizes from 1/8" to 2" NPT and orifices from 3 mm to 50 mm.

**FEATURES/BENEFITS**

- Can be oriented in any position
- Compact design
- Field replaceable coils

**APPLICATIONS**

- Wide variety of applications, suitable air, gas, water and other liquids

**SPECIFICATIONS**

**Service:** Compatible gases and liquids.  
**Line Size:** 1/8 to 2" NPT.  
**End Connections:** Female NPT.  
**Operating Pressure:** 1/8 to 1/4": 0 psi (0 bar) to 188.5 psi (13 bar); 3/8 to 2": 7.3 psi (0.5 bar) to 188.5 psi (13 bar).  
**Pressure Limit:** 246.6 psi (17 bar).  
**Wetted Material:** Body: Brass; Spring: 304 SS; Seal: NBR.  
**Temperature Limits:** Process: 176°F (80°C); Ambient: 32 to 149°F (0 to 65°C).

**Power Requirements:** Standard: 110 VAC; Optional: 220 VAC, 24 VDC, 24 VAC consult factory. Ⓢ  
**Power Consumption:** See table.  
**Enclosure Rating:** NEMA 13 (IP54).  
**Electrical Connection:** DIN connection.  
**Other Materials:** Nylon.  
**Mounting Orientation:** Any position, best if solenoid vertically above valve.  
**Weight:** See table.  
**Type of Operation:** NC.  
**Agency Approvals:** CE.

**MODEL CHART**

Model	Connection, NPT	Orifice in [mm]	Cv Value	Voltage
SBSV-B1N1	1/8"	0.12 [3]	0.23	110 VAC
SBSV-B2N1	1/4"	0.12 [3]	0.23	110 VAC
SBSV-B3N1	3/8"	0.51 [13]	4.5	110 VAC
SBSV-B4N1	1/2"	0.51 [13]	4.5	110 VAC
SBSV-B5N1	3/4"	0.79 [20]	7.6	110 VAC
SBSV-B6N1	1"	0.98 [25]	12	110 VAC
SBSV-B7N1	1-1/4"	1.38 [35]	22	110 VAC
SBSV-B8N1	1-1/2"	1.57 [40]	30	110 VAC
SBSV-B9N1	2"	1.97 [50]	48	110 VAC

Note: Consult factory for 220 VAC, 24 VAC and 24 VDC.

Voltage	50 Hz (VA)		60 Hz (VA)		DC (W)
	Inrush	Holding	Inrush	Holding	
220 VAC	55	22	55	18	-
110 VAC	55	22	55	18	-
24 VAC	45	18	45	15	-
24 VDC	-	-	-	-	13

USA: California Proposition 65

⚠ WARNING: Cancer and Reproductive Harm - www.P65Warnings.ca.gov

Ⓢ Solenoid Coils: See page 426 (Series SRC)

SERIES SBSV-S | W.E. ANDERSON™ BY DWYER



# SS SOLENOID VALVE, 2-WAY GUIDED NC

Compact Design, Immune to Mounting Orientation

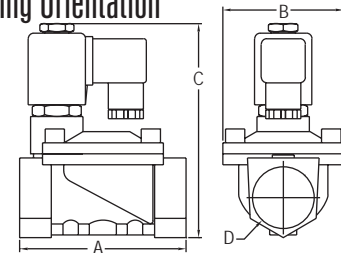

Model	A in [mm]	B in [mm]	C in [mm]	D NPT	Weight lb [kg]
SBSV-S1FX	1-5/8 [41]	1-5/32 [29]	3-9/32 [83]	1/8"	0.82 [0.37]
SBSV-S2FX	1-5/8 [41]	1-5/32 [29]	3-9/32 [83]	1/4"	0.79 [0.36]
SBSV-S3FX	2-5/8 [66]	1-57/64 [48]	4-7/16 [112]	3/8"	1.65 [0.75]
SBSV-S4FX	2-5/8 [66]	1-57/64 [48]	4-7/16 [112]	1/2"	1.54 [0.7]
SBSV-S5FX	2-61/64 [75]	2-19/64 [58]	4-21/32 [118]	3/4"	1.98 [0.9]
SBSV-S6FX	3-25/32 [96]	2-49/64 [70]	5-11/64 [131]	1"	2.87 [1.3]
SBSV-S7FX	5-11/64 [131]	3-25/32 [96]	3-3/4 [146]	1-1/4"	5.73 [2.6]
SBSV-S8FX	5-11/64 [131]	3-25/32 [96]	5-3/4 [146]	1-1/2"	5.51 [2.5]
SBSV-S9FX	6-1/2 [165]	3-47/64 [120]	6-37/64 [167]	2"	9.7 [4.4]

The Series SBSV-S SS Solenoid Valve is compact, general-service, two-way guide type solenoid valves for air, gas, water and other liquid applications. They are available in stainless steel with a normally closed design and can be oriented in any position. The solenoid enclosure provides protection against dust, while also protecting against seepage of oil and non-corrosive coolants. The Series SBSV-B valves come assembled with an NBR seal, having a maximum process temperature of 176°F (80°C). The series offers a wide range of valve sizes and flow ranges, with connection sizes from 1/8" to 2" NPT and orifices from 3 mm to 50 mm.

**FEATURES/BENEFITS**

- Can be oriented in any position
- Compact design
- Field replaceable coils

**APPLICATIONS**

- Wide variety of applications, suitable air, gas, water and other liquids

**SPECIFICATIONS**

**Service:** Compatible gases and liquids.  
**Line Size:** 1/8 to 2" NPT.  
**End Connections:** Female NPT.  
**Operating Pressure:** 1/8 to 1/4": 0 psi (0 bar) to 188.5 psi (13 bar); 3/8 to 2": 7.3 psi (0.5 bar) to 188.5 psi (13 bar).  
**Pressure Limit:** 246.6 psi (17 bar).  
**Wetted Material:** Body: 316 SS; Spring: 304 SS; Seal: Fluoroelastomer.  
**Temperature Limits:** Process: 176°F (80°C); Ambient: 32 to 149°F (0 to 65°C).  
**Power Requirements:** Standard: 110 VAC; Optional: 220 VAC, 24 VDC, 24 VAC consult factory. Ⓢ  
**Power Consumption:** See table.  
**Enclosure Rating:** NEMA 13 (IP54).  
**Electrical Connection:** DIN connection.  
**Other Materials:** Nylon.  
**Mounting Orientation:** Any position, best if solenoid vertically above valve.  
**Weight:** See table.  
**Type of Operation:** NC.  
**Agency Approvals:** CE.

**MODEL CHART**

Model	Connection, NPT	Orifice in [mm]	Cv Value	Voltage
SBSV-S1F1	1/8"	0.12 [3]	0.23	110 VAC
SBSV-S2F1	1/4"	0.12 [3]	0.23	110 VAC
SBSV-S3F1	3/8"	0.51 [13]	4.5	110 VAC
SBSV-S4F1	1/2"	0.51 [13]	4.5	110 VAC
SBSV-S5F1	3/4"	0.79 [20]	7.6	110 VAC
SBSV-S6F1	1"	0.98 [25]	12	110 VAC
SBSV-S7F1	1-1/4"	1.38 [35]	22	110 VAC
SBSV-S8F1	1-1/2"	1.57 [40]	30	110 VAC
SBSV-S9F1	2"	1.97 [50]	48	110 VAC

Note: Consult factory for 220 VAC, 24 VAC and 24 VDC.

Voltage	50 Hz (VA)		60 Hz (VA)		DC (W)
	Inrush	Holding	Inrush	Holding	
220 VAC	55	22	55	18	-
110 VAC	55	22	55	18	-
24 VAC	45	18	45	15	-
24 VDC	-	-	-	-	13

Ⓢ Solenoid Coils: See page 426 (Series SRC)



# BRASS SOLENOID VALVE, 2-WAY GUIDED NO

Compact Design, Immune to Mounting Orientation

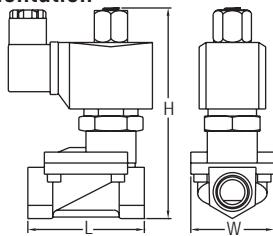

Model	L in [mm]	H in [mm]	W in [mm]	Weight lb [kg]
SSV-B1NX	1-5/8 [41]	3-15/32 [88]	1-9/64 [29]	0.88 [0.40]
SSV-B2NX	1-5/8 [41]	3-17/64 [83]	1-9/64 [29]	0.86 [0.39]
SSV-B3NX	2-19/32 [66]	4-57/64 [124]	1-57/64 [48]	1.98 [0.90]
SSV-B4NX	2-19/32 [66]	4-57/64 [124]	1-57/64 [48]	1.98 [0.90]
SSV-B5NX	2-61/64 [75]	5-1/8 [130]	2-9/32 [58]	2.42 [1.10]
SSV-B6NX	3-25/32 [96]	5-5/8 [143]	2-3/4 [70]	3.52 [1.60]
SSV-B7NX	5-5/32 [131]	6-7/32 [158]	3-25/32 [96]	6.60 [3.00]
SSV-B8NX	5-5/32 [131]	6-7/32 [158]	3-25/32 [96]	6.16 [2.80]
SSV-B9NX	6-1/2 [165]	7-3/64 [179]	4-47/64 [120]	5.00 [11.0]

The **Series SSV-B Brass Solenoid Valve** is compact, general-service, two-way guide type solenoid valves for air, gas, water, and other liquid applications. They are available in brass with a normally open design and can be oriented in any position. The solenoid enclosure provides protection against dust while also protecting against seepage of oil and non-corrosive coolants. The Series SSV-B valves come assembled with an NBR seal having a maximum process temperature of 176°F (80°C). The series offers a wide range of valve sizes and flow ranges with connection sizes from 1/8" to 2" NPT and orifices from 3 mm to 50 mm.

**FEATURES/BENEFITS**

- Can be oriented in any position
- Compact design
- Field replaceable coils

**APPLICATIONS**

- Wide variety of applications, suitable air, gas, water and other liquids

**SPECIFICATIONS**

**Service:** Compatible gases and liquids.  
**Line Size:** 1/8 to 2" NPT.  
**End Connections:** Female NPT.  
**Operating Pressure:** 1/8 to 1/4": 0 psi (0 bar) to 87 psi (6 bar); 3/8 to 2": 7.3 psi (0.5 bar) to 116 psi (8 bar).  
**Pressure Limit:** 174 psi (12 bar).  
**Wetted Material:** Body: Brass; Spring: 304 SS; Seal: NBR.  
**Temperature Limits:** Process: 176°F (80°C); Ambient: 32 to 149°F (0 to 65°C).

**Power Requirements:** Standard: 110 VAC; Optional: 220 VAC, 24 VDC consult factory. **Power Consumption:** See table.  
**Enclosure Rating:** NEMA 13 (IP54).  
**Electrical Connection:** DIN connection.  
**Other Materials:** Nylon.  
**Mounting Orientation:** Any position, best if solenoid vertically above valve.  
**Weight:** See table.  
**Type of Operation:** NO.  
**Agency Approvals:** CE.

**MODEL CHART**

Model	Connection, NPT	Orifice in [mm]	Cv Value	Voltage
SSV-B1N1	1/8"	0.12 [3]	0.25	110 VAC
SSV-B2N1	1/4"	0.12 [3]	0.25	110 VAC
SSV-B3N1	3/8"	0.51 [13]	4.5	110 VAC
SSV-B4N1	1/2"	0.51 [13]	4.5	110 VAC
SSV-B5N1	3/4"	0.79 [20]	7.6	110 VAC
SSV-B6N1	1"	0.98 [25]	12	110 VAC
SSV-B7N1	1-1/4"	1.38 [35]	22	110 VAC
SSV-B8N1	1-1/2"	1.57 [40]	30	110 VAC
SSV-B9N1	2"	1.97 [50]	48	110 VAC

Note: Consult factory for 220 VAC, 24 VAC and 24 VDC.

Voltage	50 Hz (VA)		60 Hz (VA)		DC (W)
	Inrush	Holding	Inrush	Holding	
220 VAC	82	33	82	28	-
110 VAC	82	33	82	28	-
24 VDC	-	-	-	-	32

USA: California Proposition 65

⚠ WARNING: Cancer and Reproductive Harm - www.P65Warnings.ca.gov

☛ Solenoid Coils: See page 426 (Series SRC)

# SS SOLENOID VALVE, 2-WAY GUIDED NO

Compact Design, Immune to Mounting Orientation

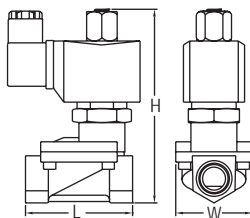

Model	L in [mm]	H in [mm]	W in [mm]	Weight lb [kg]
SSV-S1FX	1-5/8 [41]	3-15/32 [88]	1-9/64 [29]	0.88 [0.40]
SSV-S2FX	1-5/8 [41]	3-17/64 [83]	1-9/64 [29]	0.86 [0.39]
SSV-S3FX	2-19/32 [66]	4-57/64 [124]	1-57/64 [48]	2.09 [0.95]
SSV-S4FX	2-19/32 [66]	4-57/64 [124]	1-57/64 [48]	1.98 [0.90]
SSV-S5FX	2-61/64 [75]	5-1/8 [130]	2-9/32 [58]	2.42 [1.10]
SSV-S6FX	3-25/32 [96]	5-5/8 [143]	2-3/4 [70]	3.30 [1.50]
SSV-S7FX	5-5/32 [131]	6-7/32 [158]	3-25/32 [96]	6.16 [2.80]
SSV-S8FX	5-5/32 [131]	6-7/32 [158]	3-25/32 [96]	5.94 [2.70]
SSV-S9FX	6-1/2 [165]	7-3/64 [179]	4-47/64 [120]	10.1 [4.60]

The **Series SSV-S SS Solenoid Valve** is compact, general-service, two-way guide type solenoid valves for air, gas, water, and other liquid applications. They are available in stainless steel with a normally open design and can be oriented in any position. The solenoid enclosure provides protection against dust, while also protecting against seepage of oil and non-corrosive coolants. The Series SSV-S valves come assembled with a fluoroelastomer seal, having a maximum process temperature of 248°F (120°C). The series offers a wide range of valve sizes and flow ranges, with connection sizes from 1/8" to 2" NPT and orifices from 3 mm to 50 mm.

**FEATURES/BENEFITS**

- Can be oriented in any position
- Compact design
- Field replaceable coils

**APPLICATIONS**

- Wide variety of applications, suitable air, gas, water and other liquids

**SPECIFICATIONS**

**Service:** Compatible gases and liquids.  
**Line Size:** 1/8 to 2" NPT.  
**End Connections:** Female NPT.  
**Operating Pressure:** 1/8 to 1/4": 0 psi (0 bar) to 87 psi (6 bar); 3/8 to 2": 7.3 psi (0.5 bar) to 116 psi (8 bar).  
**Pressure Limit:** 174 psi (12 bar).  
**Wetted Material:** Body: 316 SS; Spring: 304 SS; Seal: Fluoroelastomer.  
**Temperature Limits:** Process: 248°F (120°C); Ambient: 32 to 149°F (0 to 65°C).

**Power Requirements:** Standard: 110 VAC; Optional: 220 VAC, 24 VDC consult factory. **Power Consumption:** See table.  
**Enclosure Rating:** NEMA 13 (IP54).  
**Electrical Connection:** DIN connection.  
**Other Materials:** Nylon.  
**Mounting Orientation:** Any position, best if solenoid vertically above valve.  
**Weight:** See table.  
**Type of Operation:** NO.  
**Agency Approvals:** CE.

**MODEL CHART**

Model	Connection, NPT	Orifice in [mm]	Cv Value	Voltage
SSV-S1F1	1/8"	0.12 [3]	0.25	110 VAC
SSV-S2F1	1/4"	0.12 [3]	0.25	110 VAC
SSV-S3F1	3/8"	0.51 [13]	4.5	110 VAC
SSV-S4F1	1/2"	0.51 [13]	4.5	110 VAC
SSV-S5F1	3/4"	0.79 [20]	7.6	110 VAC
SSV-S6F1	1"	0.98 [25]	12	110 VAC
SSV-S7F1	1-1/4"	1.38 [35]	22	110 VAC
SSV-S8F1	1-1/2"	1.57 [40]	30	110 VAC
SSV-S9F1	2"	1.97 [50]	48	110 VAC

Note: Consult factory for 220 VAC, 24 VAC and 24 VDC.

Voltage	50 Hz (VA)		60 Hz (VA)		DC (W)
	Inrush	Holding	Inrush	Holding	
220 VAC	82	33	82	28	-
110 VAC	82	33	82	28	-
24 VDC	-	-	-	-	32

☛ Solenoid Coils: See page 426 (Series SRC)

## SOLENOID REPLACEMENT COILS

For the Series SSV and SBSV Solenoid Valves

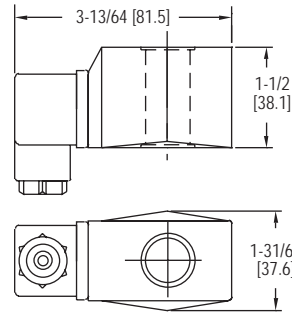

Models SRC-X180X &amp; SRC-X280X

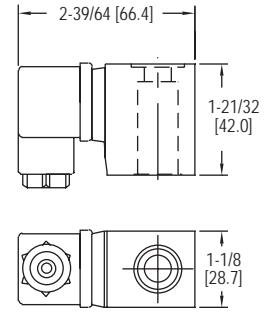

Models SRC-XXS0X

The **Series SRC Solenoid Replacement Coils** electrically operate the SSV and SBSV solenoid valves. When the solenoid coil receives an electrical input signal it acts upon the valve, changing its state. These coils are field replaceable with their compatible solenoid valves and come in a wide range of voltages.

## FEATURES/BENEFITS

- Field replaceable

## APPLICATIONS

- Replacement coils for SSV and SBSV solenoid valves

## SPECIFICATIONS

**Compatible Valves:** SSV or SBSV.

**Power Requirements:** 220 VAC, 110 VAC, 24 VAC or 24 VDC.

**Electrical Connections:** DIN connection.

**Enclosure Rating:** NEMA 13 (IP54).

**Power Consumption:** See table.

**Agency Approvals:** CE.

## SSV COMPATIBLE COILS

Model	Voltage	50 Hz (VA)		60 Hz (VA)		DC (W)
		Inrush	Holding	Inrush	Holding	
SRC-D1B0P	220 VAC	82	33	82	28	-
SRC-D2B0P	110 VAC	82	33	82	28	-
SRC-D3B0P	24 VAC	72	29	72	25	-
SRC-D4B0P	24 VDC	-	-	-	-	32

Note: Consult factory for 220 VAC, 24 VAC and 24 VDC.

## SBSV COMPATIBLE COILS

Model	Voltage	50 Hz (VA)		60 Hz (VA)		DC (W)
		Inrush	Holding	Inrush	Holding	
SRC-D1S0C	220 VAC	55	22	55	18	-
SRC-D2S0C	110 VAC	55	22	55	18	-
SRC-D3S0C	24 VAC	45	18	45	15	-
SRC-D4S0C	24 VDC	-	-	-	-	13

Note: Consult factory for 220 VAC, 24 VAC and 24 VDC.

## SERIES SN | PROXIMITY® BY DWYER

## NAMUR MOUNT SOLENOID VALVE

Manual Override, 100% Duty Rating

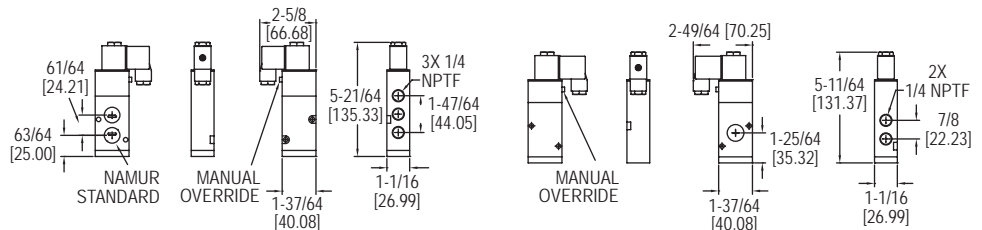

SN-5X models

SN-3X models

The **Series SN Namur Mount Solenoid Valve** is designed to easily mount directly to pneumatic valve actuators reducing the need for tubing, fittings or brackets, thereby reducing assembly cost. The SN solenoid comes with nitrile o-rings and offers a manual override as a standard feature. The 3/2 solenoids are designed for spring return actuators and 5/2 solenoids are designed to be used with double acting actuators. The SN series is available in a variety of voltages for any application.

## FEATURES/BENEFITS

- NAMUR mount means the solenoid can be mounted directly to valve actuators
- Designed for double acting or spring return actuators
- 100% continuous duty rating
- Manual override

## APPLICATIONS

- Direct mount to pneumatic actuators

MODEL CHART							
Model	Power	Action	Actuator Type	Model	Power	Action	Actuator Type
SN-5A	110 VAC	5/2	Double acting	SN-3A	110 VAC	3/2	Spring return
SN-5B	220 VAC	5/2	Double acting	SN-3B	220 VAC	3/2	Spring return
SN-5C	24 VAC	5/2	Double acting	SN-3C	24 VAC	3/2	Spring return
SN-5E	24 VDC	5/2	Double acting	SN-3E	24 VDC	3/2	Spring return
SN-5D	12 VDC	5/2	Double acting	SN-3D	12 VDC	3/2	Spring return

## SPECIFICATIONS

**Service:** Air only.

**Power Requirements:** 24 VAC, 110 VAC, 220 VAC, 12 VDC, or 24 VDC.

**Supply Pressure:** 22 to 116 psi (1.5 to 7.9 bar).

**Air Connections:** 1/4" female NPT.

**Temperature Limits:** 23 to 140°F (-5 to 60°C).

**Electrical Connection:** DIN 43650 form A.

**Enclosure Rating:** IP65.

**Mounting:** NAMUR.

**Standard Features:** Manual override.

**Weight:** 1.0 lb (.45 kg).

**Agency Approvals:** CE.



Model SN mounted to an actuator

# PILOT SOLENOID VALVE

For Use with Remote Valves



RSV1D



RSV1L

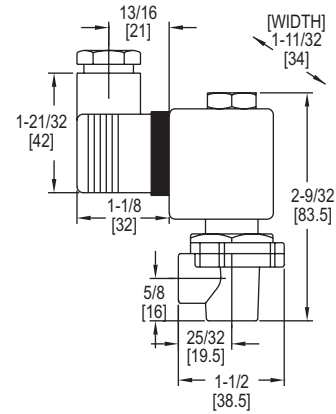

The **Series RSV Pilot Solenoid Valve** is used to operate the Series RSV remote type diaphragm valve to air pulse clean filters in dust collectors. Consult factory for mounting of RSV valves with our DCT timer boards together in one enclosure all pre-wired.

**FEATURES/BENEFITS**

- Filtered and oil-free
- Weatherproof enclosure package available
- Can be mounted with DCT timer boards in one enclosure, consult factory

**APPLICATIONS**

- For use with RDCV remote valve

MODEL CHART			
Model	Voltage	Electrical Connections	Cv Value
RSV1D	110 VAC	DIN	.33
RSV2D	220 VAC	DIN	.33
RSV3D	24 VDC	DIN	.33
RSV1L	110 VAC	Wire leads	.33
RSV2L	220 VAC	Wire leads	.33
RSV3L	24 VDC	Wire leads	.33

**SPECIFICATIONS**

**Service:** Compatible gases, filtered and oil free.  
**Wetted Materials:** Body: Aluminum; Core and spring: 304 SS; Seals: NBR.  
**Pressure Limits:** Min of 4.4 psi (0.3 bar), max of 124.7 psi (8.6 bar).  
**Temperature Limits:** Ambient: -4 to 122°F (-20 to 50°C); Operating: -4 to 185°F (-20 to 85°C).  
**Power Requirements:** 110 VAC, 220 VAC, or 24 VDC.  
**Power Consumption:** 12 W, inrush: 17 VA, holding: 14.5 VA.  
**Enclosure Rating:** NEMA 4X (IP66).  
**Electrical Connection:** DIN connection or wire leads, 18 AWG, 22" (55 cm) long.  
**Process Connection:** 1/8" female NPT.  
**Mounting Orientation:** Any position.  
**Weight:** 0.60 lb (0.27 kg).  
**Pneumatic Tube Length:** Maximum of 9.8' (3 m).  
**Agency Approvals:** CE.

**SERIES SVE**

# SOLENOID VALVE ENCLOSURES

For the Series RSV Remote Solenoid Valves



SVE06WP61

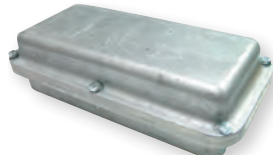

SVE06WP61

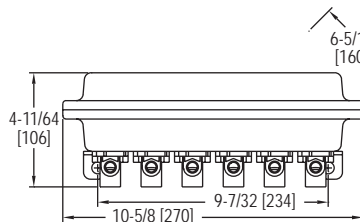

SVE06

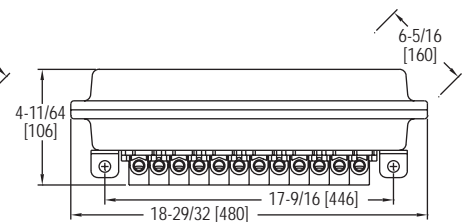

SVE12

The **Series SVE Solenoid Valve Enclosures** are multi-valve enclosures for the RSV pilot valve. The SVE offers a convenient weatherproof enclosure package with all solenoids pre-wired to a terminal block. Enclosures are available in 6 or 12 valve size with choice of pilot valve voltage.

**FEATURES/BENEFITS**

- Weatherproof enclosure
- Can order pre-wired to terminal block
- Available in 6 or 12 valve size

**APPLICATIONS**

- For use with RSV only, compatible gases

MODEL CHART			
Model	Quantity of Solenoid	Enclosure Type	Voltage
SVE06WP61	6	Weatherproof	110 VAC
SVE06WP62	6	Weatherproof	220 VAC
SVE06WP63	6	Weatherproof	24 VDC
SVE12WP121	12	Weatherproof	110 VAC
SVE12WP122	12	Weatherproof	220 VAC
SVE12WP123	12	Weatherproof	24 VDC

**SPECIFICATIONS**

**Service:** (For RSV) Compatible gases, filtered and oil free.  
**Wetted Materials:** (For RSV) Body: Aluminum; Core and spring: 304 SS; Seals: NBR.  
**Pressure Limits:** (For RSV) Min of 4.4 psi (0.3 bar), max of 124.7 psi (8.6 bar).  
**Temperature Limits:** Ambient: -4 to 122°F (-20 to 50°C); Operating: -4 to 185°F (-20 to 85°C).  
**Power Requirement:** (For RSV) 110 VAC, 220 VAC, or 24 VDC.  
**Power Consumption:** (For RSV) 12 W, inrush: 17 VA, holding: 14.5 VA.  
**Enclosure Rating:** NEMA 4X (IP66).  
**Enclosure Material:** Anodized aluminum with NBR gasket.  
**Electrical Connection:** All RSV are pre-wired to a terminal strip.  
**Process Connection:** (For RSV) 1/8" female NPT.  
**Conduit Connection:** 3/4" female NPT.  
**Mounting Orientation:** Any position.  
**Pneumatic Tube Length:** Max of 9.8' (3 m).

# DIAPHRAGM VALVES

Pulse Valves, Ideal for Dust Collection Systems and Bag Houses



DCV62T1D



DCV20C1D



RDCV62T



RDCV20C

The **Series DCV/RDCV Diaphragm Valves** are ideal for use with the Series DCT1000 and Series DCT500 duct collection timer boards for controlling the air pulse in jet pulse type dust collectors to clean the filters. Both the Series DCV and RDCV have the option for either coupling or NPT connections. The coupling connection allows for a quick and simple installation. Only the stub pipe and blowtube need to be cleaned and deburred before the valve is fit into position. The "T" Series DCV has female threaded connections. Both the "C" and "T" versions have a 90° angle between the inlet and outlet the most suitable configuration for pulse valve applications. The design offers not only ease of installation, but also minimal airflow restriction for an exceptional cleaning pulse. The valves are offered in both integrated and remote coil configurations.

#### FEATURES/BENEFITS

- Thermoplastic polyurethane diaphragm for longer life
- High flow factor for effective cleaning
- Valve can be mounted in any position
- Quick on and off response time

#### APPLICATIONS

- Dust collection systems
- Bag houses
- For use with DCT1000 and DCT500

#### SPECIFICATIONS

**Service:** Compatible gases, filtered and oil free.

**Wetted Materials:** Body: aluminum; Trim: 304 SS; Diaphragm and Seals: NBR; Diaphragm Disc: polyamide.

**Other Materials:** Cover: aluminum; Body Bolts and Spring: 304 SS.

**Pressure Limits:** Minimum of 4.4 psi (0.3 bar), maximum of 124.7 psi (8.6 bar).

**Temperature Limits:** Ambient: -4 to 140°F (-20 to 60°C) for RDCV models; -4 to 122°F (-20 to 50°C) for DCV models; Operating: -4 to 185°F (-20 to 85°C).

**Power Requirements:** 110 VAC, 220 VAC, or 24 VDC for DCV models.

**Power Consumption:** 12 W, inrush: 17 VA; holding: 14.5 VA for DCV models.

**Electrical Connection:** DIN connection for DCV models.

**Enclosure Rating:** NEMA 4X (IP65) for DCV models.

**Process Connection:** See Catalog page.

**Mounting Orientation:** Any position.

**Agency Approval:** CE.

#### MODEL CHART

Model	Size	Solenoid	Connection	Number of Diaphragms	Cv Factor (gal/min)
RDCV20T	3/4"	Remote	NPT	1	114
RDCV20C	3/4"	Remote	Coupling	1	114
DCV20T1D	3/4"	Integral*	NPT	1	114
DCV20C1D	3/4"	Integral*	Coupling	1	114
RDCV25T	1"	Remote	NPT	1	23
RDCV25C	1"	Remote	Coupling	1	23
DCV25T1D	1"	Integral*	NPT	1	23
DCV25C1D	1"	Integral*	Coupling	1	23
RDCV35T	1-1/2"	Remote	NPT	1	42
RDCV35C	1-1/2"	Remote	Coupling	1	42
DCV35T1D	1-1/2"	Integral*	NPT	1	42
DCV35C1D	1-1/2"	Integral*	Coupling	1	42
RDCV45T	1-1/2"	Remote	NPT	2	51
RDCV45C	1-1/2"	Remote	Coupling	2	51
DCV45T1D	1-1/2"	Integral*	NPT	2	51
DCV45C1D	1-1/2"	Integral*	Coupling	2	51
RDCV50T	2"	Remote	NPT	2	106
DCV50T1D	2"	Integral*	NPT	2	106
RDCV62T	2-1/2"	Remote	NPT	2	136
DCV62T1D	2-1/2"	Integral*	NPT	2	136
RDCV76T	3"	Remote	NPT	2	167
DCV76T1D	3"	Integral*	NPT	2	167

\*110 VAC with DIN Connector

#### MODEL CHART

Example	DCV	20	T	ID	DCV20T1D
<b>Construction</b>	DCV				Integrated coil
	RDCV				Remote coil
<b>Size</b>		20			3/4"
		25			1"
		35			1-1/2"
		45			1-1/2" (2 diaphragms)
		50			2"
		62			2-1/2"
		76			3"
<b>Connection</b>			T		NPT
			C		Coupling
<b>Voltage</b>				1D	110 VAC (for integrated coil only)
				2D	220 VAC (for integrated coil only)
				3D	24 VDC (for integrated coil only)

#### ACCESSORIES

Model	Description	Fits Valve Sizes
A-237	1/8" NPT	3/4", 1", 1-1/2", RSV
A-238	3/8" NPT	1-1/2", 2", 2-1/2", 3"

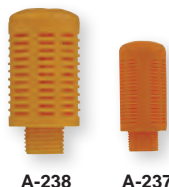

A-238

A-237

The Muffler Accessory can be easily field installed to any diaphragm valve with an exhaust. Pneumatic exhaust ports are on the diaphragm valves that have dual diaphragms and the units with the integral mounted solenoid. The muffler decreases the amount of noise when the air is exhausted from the valve. Valves with dual diaphragms and an integral solenoid have two exhaust ports and will require one A-237 and one A-238.



# DIAPHRAGM VALVES

Pulse Valves, Ideal for Dust Collection Systems and Bag Houses

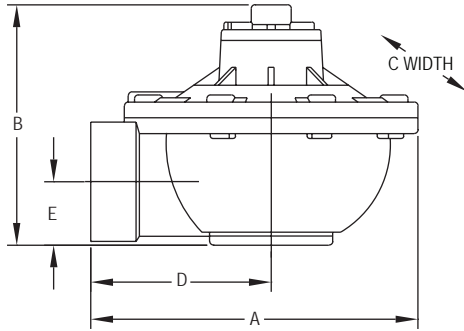

Remote NPT

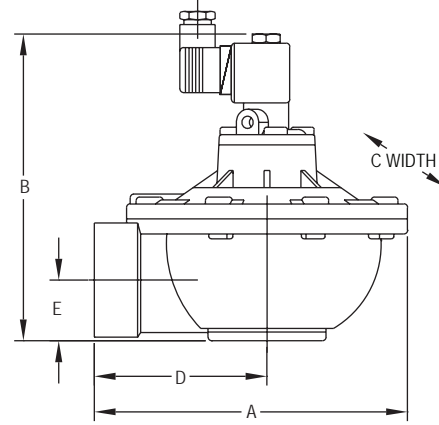

Integrated NPT

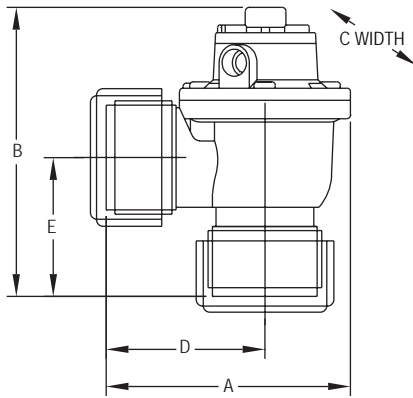

Remote coupling

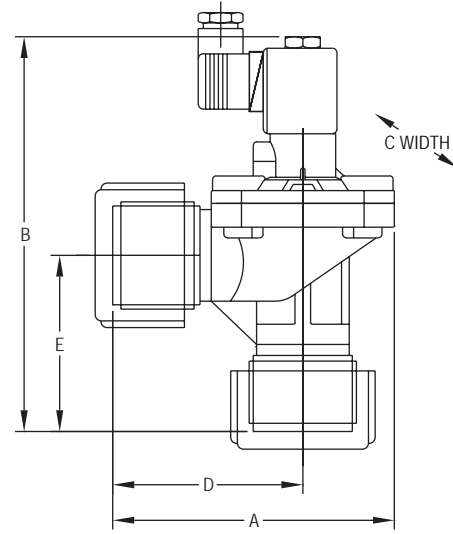

Integrated coupling

DIMENSIONAL CHART										
Solenoid	Connection	Model	A (mm)	B (mm)	C (mm)	Weight lb (kg)	D (mm)	E (mm)		
Remote	NPT	RDCV20T	3-15/16" (100)	2-31/32" (75)	3-7/16" (87)	1.12 (.51)	2-3/16" (56)	25/32" (20)		
		RDCV25T	4-1/8" (105)	3" (76)	3-1/4" (83)	1.15 (.52)	2-1/2" (64)	7/8" (22)		
		RDCV35T	5-1/8" (130)	4-29/32" (125)	4-3/8" (111)	2.0 (.91)	4-1/2" (114)	1-9/32" (33)		
		RDCV45T	5-25/32" (147)	5-5/32" (131)	4-3/8" (111)	2.2 (1.0)	3-5/8" (91)	3" (76)		
		RDCV50T	8-1/16" (205)	5-7/8" (148)	7-1/4" (184)	4.2 (1.9)	4-15/32" (113)	1-9/16" (40)		
		RDCV62T	8-9/32" (210)	6-11/16" (170)	7-1/4" (184)	5.5 (2.5)	4-21/32" (118)	1-29/32" (48)		
		RDCV76T	8-19/32" (218)	7-27/32" (199)	7-7/8" (200)	6.6 (3.0)	4-21/32" (118)	2-1/2" (63)		
	Coupling	RDCV20C	4-13/32" (112)	4" (102)	3-7/16" (87)	1.37 (.62)	2-5/8" (67)	1-25/32" (45)		
		RDCV25C	4-5/8" (117)	5" (127)	3-1/4" (83)	2.1 (.96)	3" (76)	2-3/4" (70)		
		RDCV35C	5-13/16" (147)	5-15/32" (139)	4-3/8" (111)	2.4 (1.1)	3-5/8" (91)	3" (76)		
		RDCV45C	5-25/32" (147)	6-25/32" (172)	4-3/8" (111)	3.2 (1.45)	3-5/8" (91)	3" (76)		
		Integrated	NPT	DCV20T_D	3-15/16" (100)	2-31/32" (75)	3-7/16" (87)	1.31 (.59)	2-3/16" (56)	25/32" (20)
				DCV25T_D	4-1/8" (105)	3" (76)	3-1/4" (83)	1.33 (.60)	2-1/2" (64)	7/8" (22)
				DCV35T_D	5-1/8" (130)	4-29/32" (125)	4-3/8" (111)	2.2 (.99)	4-1/2" (114)	1-9/32" (33)
DCV45T_D	5-25/32" (147)			5-5/32" (131)	4-3/8" (111)	2.4 (1.1)	3-5/8" (91)	3" (76)		
DCV50T_D	8-1/16" (205)			5-7/8" (148)	7-1/4" (184)	4.4 (2.0)	4-15/32" (113)	1-9/16" (40)		
DCV62T_D	8-9/32" (210)			6-11/16" (170)	7-1/4" (184)	5.7 (2.6)	4-21/32" (118)	1-29/32" (48)		
DCV76T_D	8-19/32" (218)			7-27/32" (199)	7-7/8" (200)	6.8 (3.1)	4-21/32" (118)	2-1/2" (63)		
Coupling	DCV20C_D	4-13/32" (112)	4" (102)	3-7/16" (87)	1.55 (.70)	2-5/8" (67)	1-25/32" (45)			
	DCV25C_D	4-5/8" (117)	5" (127)	3-1/4" (83)	2.3 (1.0)	3" (76)	2-3/4" (70)			
	DCV35C_D	5-13/16" (147)	5-15/32" (139)	4-3/8" (111)	2.6 (1.2)	3-5/8" (91)	3" (76)			
	DCV45C_D	5-25/32" (147)	6-25/32" (172)	4-3/8" (111)	3.4 (1.5)	3-5/8" (91)	3" (76)			

Valves  
Diaphragm Pulse

**Dwyer**  
SERIES BHC

# BULK HEAD CONNECTORS

## Coupling Accessories



BHC35DD

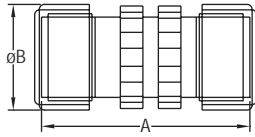

BHC35D

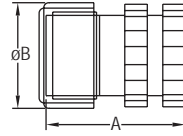

Model	A in [mm]	B in [mm]	D in [mm]	Min L in [mm]
BHC20D	2-3/8" [60.5]	2-5/16" [58.5]	1-25/32" to 2" [45 to 51]	3-27/32" [97]
BHC20DD	3-19/32" [91]	2-5/16" [58.5]	1-25/32" to 2" [45 to 51]	3-27/32" [97]
BHC25D	2-23/32" [69]	2-3/4" [70]	2-7/32" to 2-7/16" [56 to 62]	4-21/32" [118]
BHC25DD	3-31/32" [101]	2-3/4" [70]	2-7/32" to 2-7/16" [56 to 62]	4-21/32" [118]
BHC35D	2-15/16" [75]	3-15/32" [88]	2-27/32" to 3-1/16" [72 to 78]	6-3/16" [157]
BHC35DD	4-11/32" [110]	3-15/32" [88]	2-27/32" to 3-1/16" [72 to 78]	6-3/16" [157]

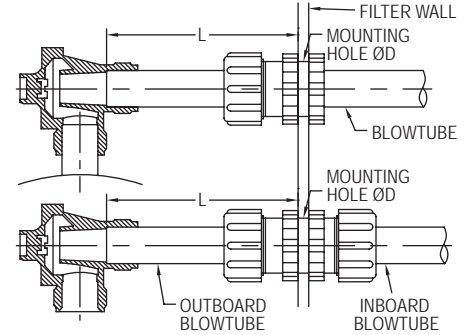

The **Series BHC Bulk Head Connectors** allow for easy installation of blow tube through the dust collector wall and eliminate the need for welding or use of additional flanges. The fittings enable easy removal and reassembly of blow tubes for cleaning and maintenance. BHC models are available in single connection for through tube mounting or double connection for two piece tube mounting.

### FEATURES/BENEFITS

- Available in single connection or double connection
- Enable easy removal and reassembly of blow tubes

### APPLICATIONS

- Dust collectors

### SPECIFICATIONS

**Service:** Compatible gases.

**Wetted Material:** Body, ring nut, DIN nut: Aluminum; Washer: SS41; Gasket: NBR.

**Pressure Limits:** 124.7 psi (8.6 bar).

**Temperature Limits:** -4 to 185°F (-20 to 85°C).

### MODEL CHART

Model	Size	Connections	Model	Size	Connections
BHC20D	3/4"	One	BHC25DD	1"	Two
BHC20DD	3/4"	Two	BHC35D	1-1/2"	One
BHC25D	1"	One	BHC35DD	1-1/2"	Two

### ACCESSORIES

Model	Description
A-237	Muffler

## SERIES BICV | W.E. ANDERSON™ BY DWYER

# BRASS INLINE CHECK VALVE

## Economical, Spring-Loaded for Fast Seating

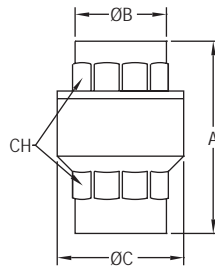

NPT Size	A in [mm]	B in [mm]	C in [mm]	CH in [mm]
1/4"	1-47/64 [44]	51/64 [20]	1-1/16 [27]	51/64 [20]
3/8"	1-47/64 [44]	51/64 [20]	1-1/16 [27]	51/64 [20]
1/2"	2-21/64 [59]	63/64 [25]	1-23/64 [34.5]	63/64 [25]
3/4"	2-9/16 [65]	1-13/64 [30.5]	1-21/32 [42]	1-7/32 [31]
1"	2-49/64 [70]	1-31/64 [37.5]	1-15/16 [49]	1-1/2 [38]
1-1/4"	2-15/16 [74.5]	1-7/8 [47.5]	2-13/32 [61]	1-57/64 [48]
1-1/2"	3-11/64 [80.5]	2-7/64 [53.5]	2-7/8 [73]	2-1/8 [54]
2"	3-3/8 [85.5]	2-11/16 [68]	3-15/32 [88]	2-41/64 [67]
2-1/2"	4-3/8 [111]	3-15/64 [82]	4-25/64 [111.5]	3-17/64 [83]
3"	4-55/64 [123.5]	3-27/32 [97.5]	5-15/64 [133]	3-55/64 [98]
4"	5-13/32 [137.5]	5 [127]	6-27/64 [163]	5-3/64 [128]

The **Series BICV Brass Inline Check Valve** is ideal for use with a broad array of service mediums including compatible oils, gases, fuels and hydrocarbons. They incorporate a soft seat for a bubble-tight shutoff and are spring-loaded for rapid reseating at high and low temperatures. The Series BICV was designed with a smooth flow profile to minimize head loss and accumulation of debris. The low 0.5 psi (0.04 bar) cracking pressure and patented guided-disc technology ensure reliability at low and high service pressure.

### FEATURES/BENEFITS

- Soft seat for bubble-tight shut off
- Spring loaded for rapid reseating at high and low temperatures
- Patented guided-disc technology

### APPLICATIONS

- To protect equipment against possible damage or contamination resulting from a reversal of flow direction

### SPECIFICATIONS

**Service:** Liquids and gases compatible with wetted material.

**Body:** 1-piece.

**Line Size:** See model chart.

**Process Connection:** Female NPT.

**Pressure Limits:** 1/4" to 2": 400 psi (27.6 bar) WOG; 2-1/2" to 4": 175 psi (12.1 bar) WOG; All sizes: 125 psi (8.6 bar) SWP.

**Wetted Materials:** Valve body: Brass (CW617N); Obstructor: Polyetherimide; Seat: 1/4": NBR rubber, 3/8" to 4": Fluoroelastomer; Spring: 302 SS.

**Temperature Limits:** 10 to 352°F (-12 to 178°C).

### MODEL CHART

Model	Connection Size	Cv Value	Weight
BICV-0N00	1/4"	4.55	3.5 oz (100 g)
BICV-0F01	3/8"	4.55	5.9 oz (168 g)
BICV-0F02	1/2"	6.0	5.1 oz (145 g)
BICV-0F03	3/4"	11.0	7.8 oz (222 g)
BICV-0F04	1"	16.9	10.9 oz (308 g)
BICV-0F05	1-1/4"	27.4	1.1 lb (.051 kg)
BICV-0F06	1-1/2"	39.1	1.6 lb (0.73 kg)
BICV-0F07	2"	60.7	2.3 lb (1.03 kg)
BICV-0F08	2-1/2"	98.4	4.8 lb (2.19 kg)
BICV-0F09	3"	158.0	6.7 lb (3.04 kg)
BICV-0F10	4"	225.4	12.4 lb (5.64 kg)

USA: California Proposition 65

⚠ WARNING: Cancer and Reproductive Harm - www.P65Warnings.ca.gov

# NEEDLE VALVE 1-VALVE BLOCK MANIFOLDS

For Use with Gas and Liquids, Pressures Up to 6000 psi

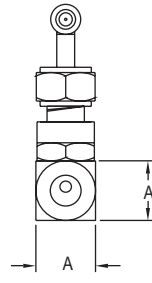
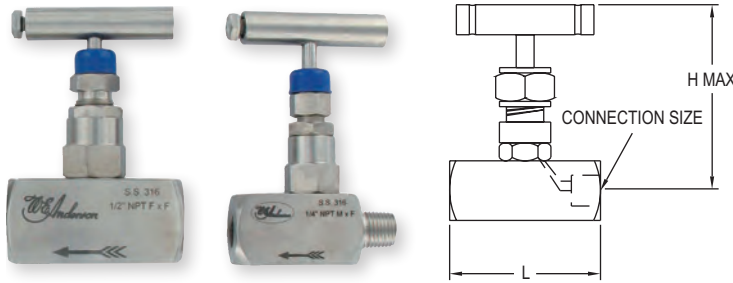

Connection	A in [mm]	L in [mm]	H in [mm]
1/8" F x F	-	1-31/32 [50.01]	-
1/8" M x F	7/8 [22.3]	2-11/64 [55.17]	2-3/8 [60.33]
1/4" F x F	-	2-3/8 [60.33]	-
1/4" M x F	63/64 [25]	2-9/16 [65.09]	2-9/16 [65.09]
3/8" F x F	-	2-3/8 [60.33]	-
3/8" M x F	63/64 [25]	2-9/16 [65.09]	2-9/16 [65.09]
1/2" F x F	-	2-9/16 [65.09]	-
1/2" M x F	1-17/64 [32.15]	2-49/64 [70.25]	2-49/64 [70.25]
3/4" F x F	-	2-61/64 [59.13]	-
3/4" M x F	1-1/2 [38.10]	3-5/32 [80.17]	3-23/64 [85.33]
1" F x F	-	3-23/64 [85.33]	-
1" M x F	1-25/32 [45.24]	4-7/64 [104.38]	3-3/4 [95.25]

**Series HNV Needle Valve 1-Valve Block Manifolds** are barstock style needle valves that is designed for isolating instruments from liquids or gases. The valve series features fine threading and large seat area to ensure tight shutoff. Wetted materials are 316 SS and PTFE making these ideal for use with corrosives. The HNV has been tested to assure vibration and thermal stability. Body includes a lock pin to prevent accidental bonnet disengagement. The HNV is available in male x female and female x female connections from 1/8" to 1". Tee handle is constructed of 316 SS and allows low torque operation.

**FEATURES/BENEFITS**

- Pressures to 6000 psi
- Fine threading and large seat area to ensure tight shutoff
- Barstock style needle valve
- 316 SS and PTFE wetted materials
- Includes lockpin to prevent accidental bonnet disengagement

**APPLICATIONS**

- Instruments line shut off, instrument isolation, drain valve, specially designed for gas service and liquid applications

**SPECIFICATIONS**

**Service:** Gases and liquids compatible with wetted materials.  
**End Connections:** NPT.  
**Wetted Materials:** 316 SS and PTFE packing.  
**Pressure Limits:** 6000 psi (431 bar) @ 200°F (93°C). 4000 psi (276 bar) @ 464°F (240°C).  
**Temperature Limits:** 464°F (240°C).  
**Other Materials:** Handle: 316 SS.

**MODEL CHART**

Pipe Size	Female x Female Model	Female x Male Model
1/8"	HNV-SSS31B	HNV-SSS21B
1/4"	HNV-SSS32B	HNV-SSS22B
3/8"	HNV-SSS33B	HNV-SSS23B
1/2"	HNV-SSS34B	HNV-SSS24B
3/4"	HNV-SSS35B	HNV-SSS25B
1"	HNV-SSS36B	HNV-SSS26B

MODEL NVII | W.E. ANDERSON™ BY DWYER

# NEEDLE VALVES

Economical, Pressures Up to 2000 psi, Blowout-Proof Stem

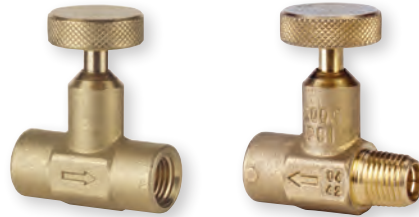

NVII-1B

NVII-2B

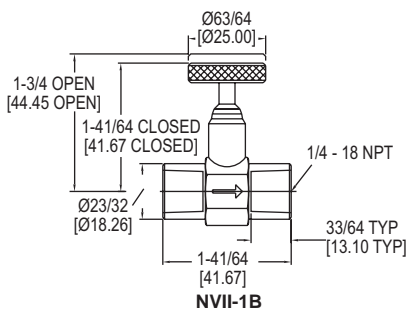

NVII-1B

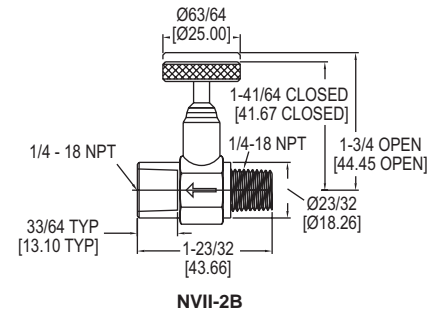

NVII-2B

The **Model NVII Needle Valves** provide easy flow regulation in all applications, including shut off and throttling for pressure gages and instruments. With a one piece, hot forged brass body construction, years of maintenance-free service can be expected. The Model NVII, with its tamper-proof design and blowout-proof stem, provides excellent performance and reliability.

**FEATURES/BENEFITS**

- Pressures to 2000 psi
- One piece body construction
- Tamper proof design and blowout-proof stem

**APPLICATIONS**

- Instrument line shut off, instrument isolation, drain valve, and pressure gages

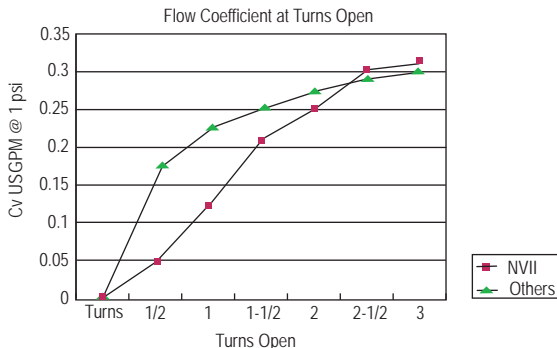

**SPECIFICATIONS**

**Service:** Gases and liquids compatible with wetted materials. Not rated for steam use.  
**End Connection Size:** 1/4" NPT.  
**Pressure Limit:** 2000 psi (138 bar) (CWP).  
**Wetted Materials:** Valve body: Brass (CW617N); Retainer, handwheel: Brass (CW614N); O-ring: Fluoroelastomer.  
**Temperature Limits:** -40 to 350°F (-40 to 176.7°C). (Warning: freezing of the fluid in the installation may severely damage the valve.)  
**Flow Coefficient:** 0.31.  
**Weight:** 0.22 lb.

**MODEL CHART**

Model	Description
NVII-1B	Needle valve (female x female)
NVII-2B	Needle valve (female x male)

USA: California Proposition 65

⚠ WARNING: Cancer and Reproductive Harm - www.P65Warnings.ca.gov

**Dwyer**

SERIES HGV | W.E. ANDERSON™ BY DWYER

**HAND OPERATED GLOBE VALVE**

Low Cost, High Pressure Rating

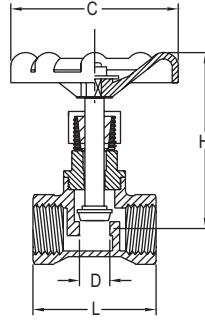

Pipe Size	D in [mm]	L in [mm]	H (Open) in [mm]	C in [mm]
1/4"	13/32 [10]	2-3/64 [52]	4-1/64 [102]	2-3/8 [60]
3/8"	15/32 [12]	2-3/64 [52]	4-1/64 [102]	2-3/8 [60]
1/2"	19/32 [15]	2-3/64 [52]	4-1/64 [102]	2-3/8 [60]
3/4"	25/32 [20]	2-3/8 [60]	4-7/16 [113]	2-3/4 [70]
1"	63/64 [25]	2-53/64 [72]	4-27/32 [123]	2-3/4 [70]
1-1/4"	1-1/4 [32]	3-5/32 [80]	5-53/64 [148]	3-5/32 [80]
1-1/2"	1-37/64 [40]	3-35/64 [90]	6-19/64 [160]	3-17/32 [90]
2"	1-31/32 [50]	4-11/64 [106]	7-3/32 [180]	3-15/16 [100]

The **Series HGV Hand Operated Globe Valve** is an economical and functional alternative to large actuator/control valve packages. Metal-to-metal seating ensures excellent flow control and shut-off service. The body and bonnet are each constructed of CF8M (316) SS for superb corrosion resistance and chemical compatibility.

**FEATURES/BENEFITS**

- Threaded ends conform to ANSI B 2.1, BS 21, DIN 259/2999, ISO 228
- SS inside screw, screwed bonnet, swivel disc integral seat, rising stem and hand wheel

**APPLICATIONS**

- Compatible liquids & gases
- Used for regulation of flow pipelines

**SPECIFICATIONS**

**Service:** Compatible liquids and gases.  
**End Connections:** Female NPT.

**Pressure Limits:** 725 psi (50.0 bar) from -20 to 200°F (-28.9 to 93.3°C); 500 psi (34.5 bar) at 300°F (148.9°C); 450 psi (31.0 bar) at 325°F (162.8°C); 100 psi (6.9 bar) at 350°F (176.7°C).

**Wetted Materials:** Body, bonnet, packing nut: CF8M (316) SS. disc, stem, retainer ring; Gland: 316 SS; Packing: PTFE.

**Temperature Limits:** -20 to 356°F (-28.9 to 180°C).

**Other Materials:** Hand wheel: Cast iron; Plate: Aluminum; Wheel nut: 316 SS.

**MODEL CHART**

Model	Size	Cv Value	Model	Size	Cv Value
HGV00	1/4"	0.6	HGV04	1"	10.69
HGV01	3/8"	1.38	HGV05	1-1/4"	17.1
HGV02	1/2"	2.46	HGV06	1-1/2"	25.2
HGV03	3/4"	5.76	HGV07	2"	47.1

SERIES BYS &amp; SYS | W.E. ANDERSON™ BY DWYER

**BRASS OR STAINLESS STEEL Y-STRAINERS**

Cost Effective, Excellent Filtration, High Flow



BYS ++

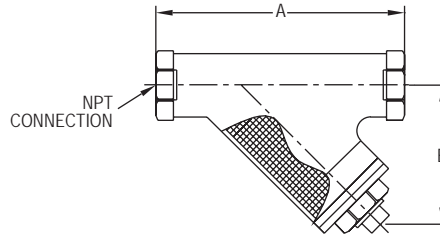

SYS

**BYS DIMENSIONS**

NPT Size	A in [mm]	B in [mm]
1/4"	1-31/32 [50.04]	2-11/16 [68.07]
3/8"	1-31/32 [50.04]	2-11/16 [68.07]
1/2"	1-31/32 [50.04]	2-11/16 [68.07]
3/4"	2-23/64 [59.94]	3-59/64 [99.57]
1"	2-41/64 [67.06]	4-17/32 [115.06]
1-1/4"	3-3/16 [81.03]	5-25/64 [136.91]
1-1/2"	3-7/16 [87.12]	6-17/64 [159.00]
2"	4-19/64 [108.97]	7-31/64 [189.99]

**SYS DIMENSIONS**

NPT Size	A in [mm]	B in [mm]
1/4"	2-33/64 [64.00]	1-27/32 [46.99]
3/8"	2-33/64 [64.00]	1-27/32 [46.99]
1/2"	2-33/64 [64.00]	1-27/32 [46.99]
3/4"	3-1/16 [78.00]	2-15/64 [56.90]
1"	3-35/64 [90.00]	2-41/64 [67.06]
1-1/4"	4-11/64 [106.00]	2-53/64 [71.88]
1-1/2"	4-11/16 [119.00]	3-5/32 [80.01]
2"	5-33/64 [140.00]	3-21/32 [92.96]

The **Series BYS & SYS Brass or Stainless Steel Y-Strainers** are a cost effective option for use in any type of industrial application. Versatile Y configuration and availability in a wide range of sizes allow for many different uses. Body, cap, and plug are made from either a high quality brass or stainless steel to ensure reliability. The seal is constructed of PTFE to ensure long service life. The stainless steel strainer provides excellent filtration to help prevent damage to valves, meters, etc. from rust and dirt, without sacrificing high flow characteristics.

**FEATURES/BENEFITS**

- Cost effective
- Stainless steel strainer

**APPLICATIONS**

- Ideal for installations upstream to protect pumps, control valves, regulators, etc from rust, pipe scale dirt

**SPECIFICATIONS**

**Service:** Gases, steam and liquids compatible with wetted materials.

**End Connections:** Female NPT.

**Pressure Limits:** See model chart.

**Temperature Limits:** -10 to 250°F (-23 to 121°C).

**Wetted Materials:** BYS: Valve Body: Cast brass; Cap and plug: Brass; Screen: SS; Seal: PTFE; SYS: Valve body and cap: Cast 316 SS (CF8M); Plug and screen: 316 SS; Seal: PTFE.

**MODEL CHART**

Model	Pipe Size	Max. Pressure	Model	Pipe Size	Max. Pressure
BYS-00	1/4"	400 psi (27.6 bar)	SYS-00	1/4"	800 psi (55.2 bar)
BYS-01	3/8"	400 psi (27.6 bar)	SYS-01	3/8"	800 psi (55.2 bar)
BYS-02	1/2"	400 psi (27.6 bar)	SYS-02	1/2"	800 psi (55.2 bar)
BYS-03	3/4"	400 psi (27.6 bar)	SYS-03	3/4"	800 psi (55.2 bar)
BYS-04	1"	300 psi (20.7 bar)	SYS-04	1"	800 psi (55.2 bar)
BYS-05	1-1/4"	300 psi (20.7 bar)	SYS-05	1-1/4"	800 psi (55.2 bar)
BYS-06	1-1/2"	300 psi (20.7 bar)	SYS-06	1-1/2"	800 psi (55.2 bar)
BYS-07	2"	300 psi (20.7 bar)	SYS-07	2"	800 psi (55.2 bar)

++USA: California Proposition 65

⚠WARNING: Cancer and Reproductive Harm - www.P65Warnings.ca.gov



# 2-VALVE BLOCK MANIFOLDS

Stainless Steel Body, NPT Connections

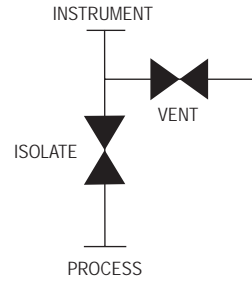
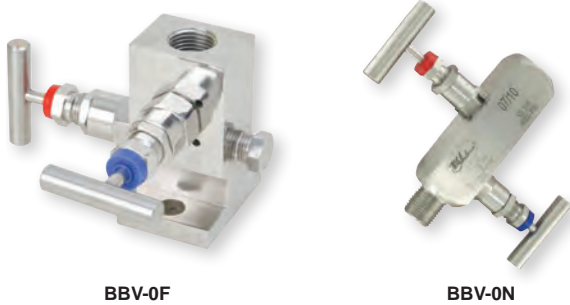

The **Series BBV-0 2-Valve Block Manifolds** are perfect for use over a broad range of industrial applications including oil refineries, nuclear power stations, petrochemical processing, and more. The Series BBV-0 is forged from 316 stainless steel bar stock and designed to withstand repeated open and close operations. Suited to control oil, water, toxic fluids, chemicals, air, and steam; the 2-valve block manifold has (1) isolate and (1) vent valves. Each valve stem is precision machined with hard seats to reduce operating torque.

**FEATURES/BENEFITS**

- 6000 psi pressure limit
- 316 SS body, stem and valve assembly
- PTFE stem packing

**APPLICATIONS**

- Industrial gage or transmitter isolation

**SPECIFICATIONS**

**Service:** Compatible liquids, gases, or steam.  
**End Connections:** Process connection: 1/2" male NPT; Instrument connection: No flange; 1/2" female NPT; Flange: 1/2" DIN 19213 flange; Vent/test: 1/4" female NPT.  
**Wetted Materials:** Body, stem, valve assembly: 316 SS; Stem packing: PTFE.  
**Pressure Limit:** 6000 psi (400 bar).  
**Temperature Limit:** 464°F (240°C).  
**Other Materials:** Handle: 304 SS.

**MODEL CHART**

Model	Description
BBV-0F	Flanged 2-valve block manifold
BBV-0N	2-valve block manifold

SERIES BBV-1 | W.E. ANDERSON™ BY DWYER

# 3-VALVE BLOCK MANIFOLDS

Stainless Steel Body, NPT Connections

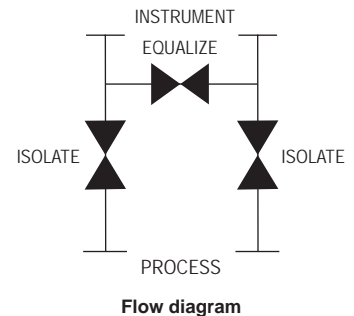
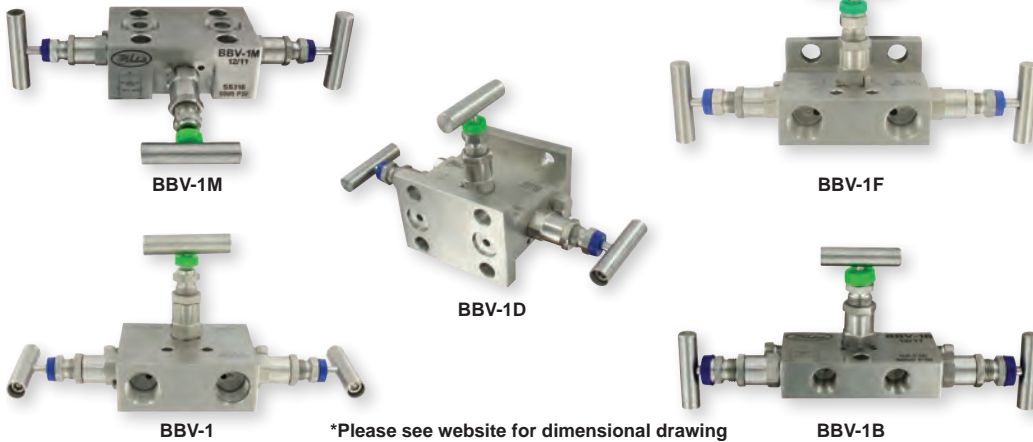

The **Series BBV-1 3-Valve Block Manifolds** can be used over a broad range of industrial applications including oil refineries, nuclear power stations, petrochemical processing, and more. The Series BBV-1 body is forged from 316 stainless steel bar stock and designed to withstand repeated open and close operations. Suited to control oil, water, toxic fluids, chemicals, air, and steam.

**FEATURES/BENEFITS**

- High pressure shut-off
- All stainless steel and PTFE wetted materials
- Precision machined hard seats to reduce operating torque

**APPLICATIONS**

- Industrial gage or transmitter isolation

**SPECIFICATIONS**

**Service:** Compatible liquids, gases, or steam.  
**End Connections:** BBV-1B: 1/4" NPT x 1/4" NPT; BBV-1: 1/2" NPT x 1/2" NPT; BBV-1F: 1/2" NPT x DIN 19213 flange; BBV-1M: 1/2" NPT x DIN 19213 flange; BBV-1D: DIN 19213 flange x DIN 19213 flange.  
**Wetted Materials:** Body, stem, valve assembly: 316 SS; Stem packing: PTFE.  
**Pressure Limit:** 6000 psi (400 bar).  
**Temperature Limit:** 464°F (240°C).  
**Other Material:** Handle: 304 SS.

**MODEL CHART**

Model	Description
BBV-1B	Mini 3-valve block manifold
BBV-1	3-valve block manifold
BBV-1F	Flanged 3-valve block manifold
BBV-1M	Multiplanar 3-valve manifold
BBV-1D	Double flanged 3-valve block manifold

# 5-VALVE BLOCK AND BLEED MANIFOLDS

Stainless Steel Body, NPT Connections



BBV-21



BBV-21F

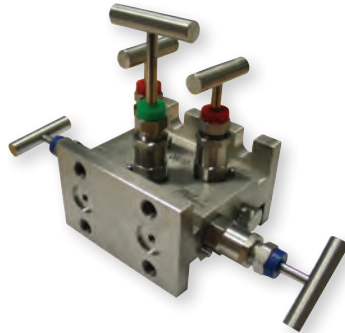

BBV-23F



BBV-22

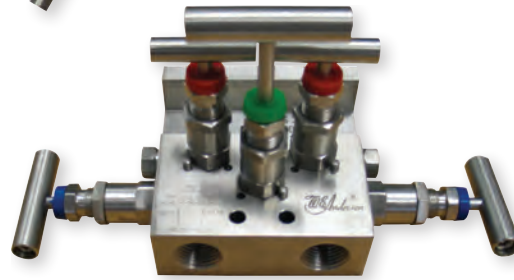

BBV-22F

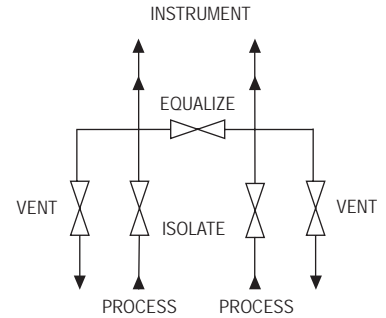

Flow diagram

Series BBV-2 5-Valve Block and Bleed Manifolds are ideal for use over a broad range of industrial applications including oil refineries, nuclear power stations, petrochemical processing, and more. The Series BBV-2 body is forged from 316 stainless steel bar stock and designed to withstand repeated open and close operations. Suited to control oil, water, toxic fluids, chemicals, air, and steam; the 5-Valve Block and Bleed Manifold has (2) isolate, (1) equalizing, and (2) vent valves. Each valve stem is precision machined with hard seats to reduce operating torque.

Flanged models are designed to mount to an industrial differential pressure transmitter. The BBV-21F and BBV-22F come with four 7/16-20 UNF mounting bolts and two PTFE gaskets. The BBV-23F comes with eight 7/16-20 UNF mounting bolts and two PTFE gaskets.

#### FEATURES/BENEFITS

- High pressure shut-off
- All stainless steel and PTFE wetted materials
- Precision machined hard seats to reduce operating torque

#### APPLICATIONS

- Industrial gage or transmitter isolation

#### SPECIFICATIONS

**Service:** Compatible liquids, gases, or steam.

**End Connections:** Process connection: No flange: 1/2" female NPT; Flange: DIN 19213 flange; Instrument connection: No flange: 1/2" female NPT; Flange: DIN 19213 flange; Vent/test: 1/4" female NPT.

**Wetted Materials:** Body, stem, valve assembly: 316 SS; Stem packing: PTFE.

**Pressure Limit:** 6000 psi (400 bar).

**Temperature Limit:** 464°F (240°C).

**Other Materials:** Handle: 304 SS.

#### MODEL CHART

Model	Description
BBV-21	5-valve manifold with side mounted vent valves
BBV-21F	Flanged 5-valve manifold with side mounted vent valves
BBV-22	5-valve manifold with top mounted vent valves
BBV-22F	Flanged 5-valve manifold with top mounted vent valves
BBV-23F	Double flanged 5-valve manifold with top mounted vent valves

# QUICK-VIEW® VALVE POSITION INDICATORS/SWITCHES

Ultra-Low Cost, Compact, Backlit, Corrosion Resistant

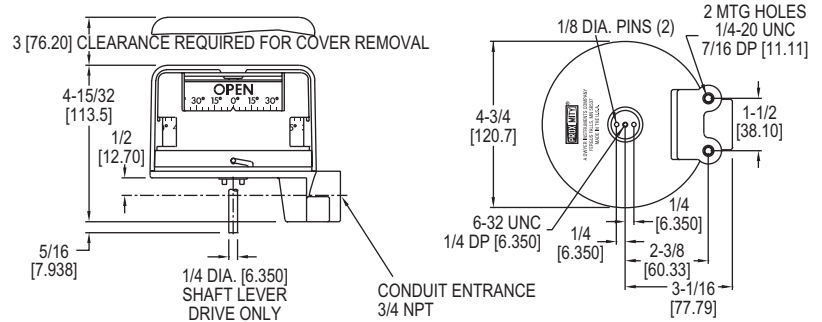

The Series QV Quick-View® Valve Position Indicators/Switches, now UL and CSA rated, are produced by Proximity with up to four individual mechanical or proximity switches. The Quick-View® indicator is also available with optional backlighting.

**FEATURES/BENEFITS**

- The lowest cost position indication
- Extremely compact design
- Easily interchangeable with key competition
- Backlighting option available for maximum visibility
- Quick-View® Indicator and mounting kits, including NAMUR kits, are stocked for fast delivery
- Flame retardant
- UV protection
- Hazardous location option

**APPLICATIONS**

- Rotary or linear valve indication
- Industrial damper position monitoring

**SPECIFICATIONS**

**Minimum Rotation Travel (Switches only):** 5°.  
**Maximum Rotation Travel (Switches only):** 360°.  
**Temperature Limits:** -40 to 180°F (-40 to 82°C).  
**Switch Type:** SPDT.  
**Electrical SPDT Switch Ratings:** QV-X1XXXX: 10 A @ 125/250 VAC; 0.5 A 125 VDC; 10 A @ 24 VDC mech. switch; QV-X2XXXX: 1 A @ 125 VAC; 1A @ 24 VDC mech. switch; QV-X3XXXX: 2 A @ 125 VAC; 2A @ 30 VDC prox. switch; QV-X4XXXX: 5-25 VDC namur sensor; QV-X5XXXX: 10-30 VDC inductive sensor; QV-X6XXXX: 10 A @ 125/250 VAC mech. switch.  
**Lighting Supply Voltage:** 24-28 VDC.  
**Enclosure Material:** Polycarbonate housing and conduit.  
**Conduit Entrance:** One 3/4" NPT.  
**Enclosure Rating:** NEMA 4, 4X (IP66, IP56). Optional explosion-proof, rated: Class I, Groups A, B, C, D; Class II, Groups F & G; Div. 2.  
**Maximum Altitude:** 2000 m (6560 ft).  
**Agency Approvals:** CE, CSA, cULus.

MODEL CHART	
Model	Backlighting
QV-210101	No
QV-210111	Yes
<p><b>Note:</b> Stocked position indicators include two 10 amp SPDT mechanical snap switches, are direct drive type and include the standard quarter-turn OPEN/CLOSED visual indicator. Standard units are CSA &amp; UL approved but not for hazardous locations. Specify "EX" for hazardous location option. Consult factory for optional VI colors</p>	



Model QV mounted to an actuator

MODEL CHART							
Example	QV	-2	1	01	0	1	QV-210101
<b>Series</b>	QV						Quick-View® valve position indicator/switch
<b>Number of Switches</b>		0	1	2	3	4	None* One* Two* Three* Four*
<b>Switch Type</b>		0	1	2	3	4	No switches* 10A mechanical snap switch 1A mechanical gold contacts 2A Proximity reed switch* 5-25 VDC namur sensor 10-30 VDC inductive sensor 10A mechanical snap switch
<b>Driving Style</b>			01	02	03		Direct* Lever* Namur*
<b>Lighting Option</b>				0	1		None* 24 to 28 VDC bright white LED's
<b>Visual Indication</b>					0	1	None Standard (open closed)* Upside down (open closed)*
<b>Additional Options</b>						EX	Class I, Div. II, Groups A, B, C & D; Class II, Div. II Groups F & G.
*EX, Explosion-proof option available.							<b>Note:</b> The 1st, 2nd, 3rd and 6th codes can not all be zero.

Position Indicators/  
Switches/Transmitters

# POSITION INDICATORS/SWITCHES/TRANSMITTERS



**Mark 1**  
stainless steel  
(environmentally sealed  
for corrosive areas)



**Mark 1**  
polyester coated aluminum  
(environmentally sealed  
for corrosive areas)

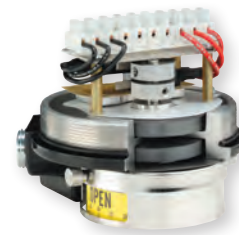

**Mark 1**  
magnetic coupling cutaway  
Model 12VDOJ2



**Mark 3**  
multi turn



**Mark 4**  
thru-shaft cutaway  
Model 42RDOJ2



The Proximity™ Series Mark Position Indicators/Switches/Transmitters are a line of position indicators with a selection of various output options. Three model styles make up the Mark series to cover almost any application. Standard models in the Mark Series have visual position indicators and are weatherproof, explosion-proof, and submersible. A large variety of outputs are available to fit specific applications. There is a choice of 1 to 6 switch outputs of 14 varieties including inductive sensors, high temperature switches, gold contact switches, hermetically sealed switches, and high current switches. Besides the switch outputs the Series offers potentiometer outputs, transmitters, and HART® Communication. The units are purchased for either direct drive applications, such as rotary valves, or lever drive applications, such as linear valves. Adjustable visual indicator is standard on direct drive units that displays OPEN / CLOSED status and degrees.

A magnetic drive that completely seals the switch compartment from the atmosphere for maximum leak protection is utilized in the Mark 1. The Mark 3 uses the same magnetic drive of the Mark 1, but it can be used for multi-turn applications with 1 to 25 revolutions, such as gate valves. A through shaft drive is incorporated in the Mark 4 making the unit a more cost effective alternative to the Mark 1 for applications that are not as demanding.

#### APPLICATIONS

- Rotary valve actuators and dampers
- Linear valve actuators and cylinders
- Manual valves
- Gear operators
- Positioners

#### MARK 1 FEATURES/BENEFITS

- Features a magnetic coupling that isolates the switch compartment, completely sealing the unit from the surrounding atmosphere for maximum hazard and leak protection
- EZ set cams on switch models provide simple set point adjustment
- Flexible design allows multiple switches and transmitter options
- Ideal for corrosive environments

#### MARK 3 FEATURES/BENEFITS

- Features a magnetic coupling that isolates the switch compartment, completely sealing the unit from the surrounding atmosphere for maximum hazard and leak protection
- Multi-Turn models that can provide switch signals between 1 and 25 revolutions, and transmitter models for up to 10 revolutions without gear reduction
- Flexible design allows multiple switches and transmitter options
- Ideal for corrosive environments

#### MARK 4 FEATURES/BENEFITS

- Thru-Shaft design that features a 1" bushing for long life and O-rings to seal the switch compartment for hazard, corrosion, and leak protection
- EZ set cams on switch models provide simple set point adjustment
- Flexible design allows multiple switches and transmitter options
- A more cost effective alternative to the Mark 1 Series for less demanding applications

#### MODEL CHART

Model	Function	Design	Model	Function	Design
12AD0	2 SPDT	Magnetic coupling	42AD0	2 SPDT	Thru-shaft drive
12AL0	2 SPDT (lever drive)	Magnetic coupling	44AD0	4 SPDT	Thru-shaft drive
14AD0	4 SPDT	Magnetic coupling	45VD0	2 SPDT and 4 to 20 mA position transmitter	Thru-shaft drive
15VD0	2 SPDT and 4-20 mA position transmitter	Magnetic coupling	42VD0-J1	2 SPDT	Thru-shaft drive
12AD1	2 SPDT	Magnetic coupling	44VD0-J1	4 SPDT	Thru-shaft drive
14AD1	4 SPDT	Magnetic coupling			
12VD0-J1	2 SPDT	Magnetic coupling			
14VD0-J1	4 SPDT	Magnetic coupling			



**Mark Series**  
mounted to an actuator

Mounting kits with drive yoke (see drawing), or slotted lever arm, bracket, fasteners and other stainless steel hardware fit over 2000 popular valves and actuators. A high strength spring tempered stainless steel drive yoke/coupling is tailored to fit securely to a specific valve or actuator stem. There is no slippage or binding. No special alignment fixtures are required due to switch offset design and yoke to stem engagement that makes installation a "snap". Each kit is specially designed for a particular valve or actuator, making field mounting simple with standard tools. Please specify make and model of valve or actuator on order.

Mounting kits can be used interchangeably with all models since external mounting features are identical. Rotary valves utilize direct drive couplings and a slotted lever drive is used with linear valves. Lever drives convert linear motion to rotary. Stainless steel visual indicators are standard for direct drive, automated quarter-turn valve applications.

HART® is a registered trademark of Hart Communication Foundation



# POSITION INDICATORS/SWITCHES/TRANSMITTERS

Construction	1 3 4			Mark 1, Magnetic Coupling Mark 3, Multi-Turn Mark 4, Thru-Shaft	Available Options "A" signifies available with corresponding construction style		
					Mark		
					1	3	4
Output Type	1 2 3 31 32 35 310 320 4 5 51 52 7 8 9			1 Switch 2 Switches 1 kΩ Potentiometer 1/2%. Available with switches, see note below.* 1 kΩ Potentiometer 1/4%. Available with switches, see note below.* 2 kΩ Potentiometer. Available with switches, see note below.* 5 kΩ Potentiometer. Available with switches, see note below.* 10 kΩ Potentiometer. Available with switches, see note below.* 20 kΩ Potentiometer. Available with switches, see note below.* 4 Switches Transmitter 1 kΩ Potentiometer 1/2%. 4-20 mA. Available with switches, see note below.* Transmitter 1 kΩ Potentiometer 1/4%. Available with switches, see note below.* Transmitter 2 kΩ Potentiometer. Available with switches, see note below.* AS-interface and 1 Switch. Available with Switch Types B, I, R, W. AS-interface and 2 Switches. Available with Switch Types B, I, R, W. Transmitter with HART® communication. Available with switches, see note below.*	A	--	A
Switch Type and Rating		A B C D G H I M O R S T V W		SPDT Snap, Rated: 15 A @ 125/250/480 VAC (-) ; 1/8 hp @ 125 VAC (-), 1/4 hp @ 250 VAC (-), 1/2 A @ 125 VDC (---), 1/4 A @ 250 VDC (---). Inductive Sensor. 10 to 30 VDC (---). Load: 0.1 A. SPDT High Temperature Snap, 350°F (176°C) for 600 hours, Rated: 15.1 A @ 125/250/277 VAC (-). DPDT Snap, Rated: 10 A @ 125/250 VAC (-), 0.3 A @ 125 VDC (---), 0.15 A @ 250 VDC (---). SPDT Gold Contact Snap, Rated: 1 A @ 125 VAC (-). SPDT Hermetically Sealed Snap, Rated: 1 A @ 125 VAC (-). NAMUR Inductive Sensor. 15 mA max @ 5-25 VDC (---). SPDT Magnetic Blow-Out, Rated: 10 A @ 125 VAC (-)/VDC (---), 1/4 hp @ 125 VAC (-)/VDC (---). No Switches SPDT Hermetically Sealed Reed, Rated: 2 A @ 125 VAC (-), 2 A @ 24 VDC (---). SPDT Snap, Rated: 4 A @ 125/250 VAC (-). SPDT High Temperature Snap, 250°F (121°C) Continuous, Rated: 5 A @ 125/250/480 VAC (-). SPDT Snap, Rated: 10 A @ 125/250 VAC (-), 1/3 hp @ 125/250 VAC (-), 1/2 A @ 125 VDC (---), 1/4 A @ 250 VDC (---), 4 A @ 125 VAC (-) (tungsten). SPDT Gold Contact Snap, Rated 0.1 A @ 125 VAC (-).	A	A	A
Driving Method		A D E L M		A Direct or Yoke Drive without Visual Indicator. Direct Drive (or Yoke) with Visual Indicator. Direct or Yoke Drive with Visual Indicator, Single Window. Lever Drive (Shaft Projection) without Visual Indicator. Lever (Shaft Projection) with Visual Indicator.	A	A	A
Enclosure			0 1 2 5 6 7 thru 20	Aluminum, Painted Black Aluminum, Painted White Epoxy with SS trim Aluminum, Painted Red Aluminum, Painted (color not yet specified) Cast 316 Stainless Steel Aluminum, Painted (color not yet specified)	A	A	A
Options				C1 Long Dwell Cam (not on Mark 3) C2 Double Cam (not on Mark 3) FKM FKM Seals J1 Junction Package with One 1/2" NPT Female Conduit Connection and Terminal Strip. J2 Junction Package with Two 1/2" NPT Female Conduit Connection and Terminal Strip. SV1 1 Attached Solenoid Valve (Must be ordered with J1 option). SV2 2 Attached Solenoid Valves (Must be ordered with J2 option). MT Metric Threaded Conduit Connection, M25 X 1.5 (M20 X 1.5 for optional J1 and J2 connections). B Any Output Type except 91: Directive 2014/34/EU, KEMA 03ATEX2391 X, CE 0518 Ex II 2G Ex db IIC T6 Gb (-25/-40/-50°C ≤ Tamb ≤ 70°C and T5 for -25°C/-40°C/-50°C ≤ Tamb ≤ 80°C). Depending on output switch type selected. B Output Type 91: Directive 2014/34/EU, KEMA 03ATEX2391 X, CE 0518 Ex II 2G Ex db IIC T4 Gb (-40°C ≤ Tamb ≤ 80°C). IS Any Output Type except 91: Directive 2014/34/EU, KEMA 03ATEX1392 X, CE 0518 Ex II 1G Ex ia IIC T4 Ga. IS Output Type 91: Directive 2014/34/EU, KEMA 03ATEX1392 X, CE 0518 Ex II 1G Ex ia IIC T4 Ga for -40°C ≤ Tamb ≤ 80°C. IE Any Output Type except 91: IECEx DEK 11.0056X Ex db IIC T6 Gb (-25/-40/-50°C ≤ Tamb ≤ 70°C and T5 for -25/-40/-50°C ≤ Tamb ≤ 80°C) optional wording depending on output and switch type selected. IE Output Type 91: IECEx DEK 11.0056X, Ex db IIC T4 Gb. II Any Output Type except 91: IECEx DEK 11.0061X Ex ia IIC T4 Ga. II Output Type 91: IECEx DEK 11.0061X Ex ia IIC T4 Ga. EM Certificate NCC 13.02339X; Marking: Ex d IIC T6 Gb or Ex d IIC T5 Gb IM Certificate: NCC 13.02338X; Marking: Ex ia IIC T4 Ga LB Output Type 91 with Suffix B Directive 2014/34/EU, KEMA 03ATEX2391 X, CE 0518 Ex II 2G Ex db IIC T4 Gb (-40°C ≤ Tamb ≤ 80°C). Battery not included. LB Output Type 91 with Suffix IS Directive 2014/34/EU, KEMA 03ATEX1392 X, CE 0518 Ex II 2G Ex ia IIC T4 Ga for -40°C ≤ Tamb ≤ 80°C. Battery not included. LB Output Type 91 with Suffix IE IECEx DEK 11.0056X, Ex db IIC T4 Gb. Battery not included. LB Output Type 91 with Suffix II IECEx DEK 11.0061X Ex ia IIC T4 Ga. Battery not included. PP Plug J1, J2 Ports PT Paper Tag STR Stainless Steel Tag Riveted STW Stainless Steel Tag Wired	A	--	A

\*Note: Mark 1 and 4 potentiometer and transmitter outputs will have no switches when ordered with switch type O; 2 switches if ordered with switch types B, C, D, I, R, V, or W; and 4 switches if ordered with switch type S. Mark 3 potentiometer and transmitter outputs will have no switches when ordered with switch type O, and 2 switches if ordered with switch types A, D, G, M or T.  
Example: 12VD0-J1. Mark 1, 2 Switches both Type V – SPDT, Direct Drive, Painted Aluminum Enclosure with Junction Package.  
Example: 15VD0. Mark 1, 2 Switches both Type V – SPDT, 4-20 mA transmitter, Direct Drive, Painted Aluminum Enclosure.

# POSITION INDICATORS/SWITCHES/TRANSMITTERS

CLEARANCE REQUIRED  
FOR COVER REMOVAL

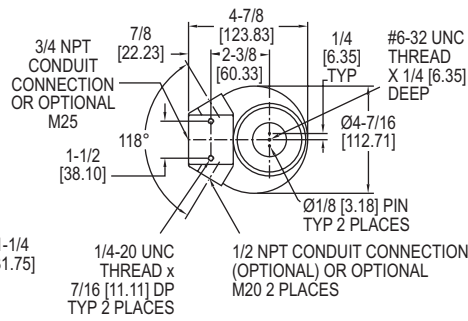
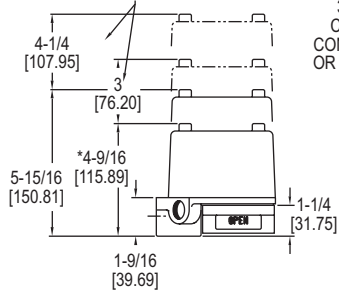

DIRECT DRIVE

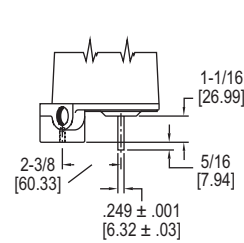

LEVER DRIVE

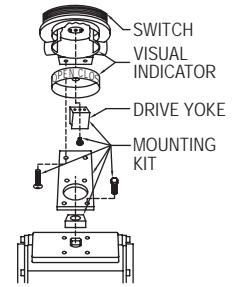

For Models 11, 12, 41 & 42

## SPECIFICATIONS

### Mark 1, 3, and 4 with Potentiometer

**Accuracy:** ± 0.5% of full span. Optional ± 0.25% of full span.

**Temperature Limits:** -40 to 176°F (-40 to 80°C). (ATEX flameproof, -B suffix and IECEx flameproof, -IE suffix, rated -40 to 145°F (-40 to 63°C) for switch types A, G, M, O, R, S, T, V, or W, -13 to 145°F (-25 to 63°C) for switch types B, D, or I; ATEX intrinsically safe, -IS suffix and IECEx intrinsically safe, -II suffix, rated -13 to 104°F (-25 to 40°C) for switch type I, -40 to 104°F (-40 to 40°C) for switch types O, R, S, V, or W.

**Power Rating:** 1.5 Watt maximum.

**Output Signal:** 1000 Ω standard. Optional 2000, 5000, 10000, or 20000 Ω.

**Zero and Span Adjustments:** Span trim pot with 2000Ω adjustment. No zero adjustment.

**Rotational Travel:** Mark 1 and 4: Minimum: 0°, Maximum: 340°. Mark 3: 0 to 10 revolutions.

### Mark 1, 3, and 4 with Transmitter

**Accuracy:** ± 0.5% of full span. Optional ± 0.25% of full span.

**Temperature Limits:** -40 to 176°F (-40 to 80°C). (ATEX flameproof, -B suffix and IECEx flameproof, -IE suffix, rated -40 to 145°F (-40 to 63°C) for switch types A, G, M, O, R, S, T, V, or W, -13 to 145°F (-25 to 63°C) for switch types B, D, or I; ATEX intrinsically safe, -IS suffix and IECEx intrinsically safe, -II suffix, rated -13 to 104°F (-25 to 40°C) for switch type I, -40 to 104°F (-40 to 40°C) for switch types O, R, S, V, or W.

**Power Requirements:** 5-30 VDC.

**Current Consumption:** 50 mA.

**Output Signal:** 4-20 mA.

**Zero and Span Adjustments:** Trim pots for adjusting both. Mark 1 and 4: Span is adjustable from 50 to 300°. Mark 3: Span is adjustable from 1.5 to 8.5 revolutions.

**Conduit Connection:** 3/4" female NPT standard. Optional one or two 1/2" female NPT. M25 X 1.5 and M20 X 1.5 optional.

**Rotational Travel:** Mark 1 and 4: Minimum: 50°, Maximum: 300°. Mark 3: Minimum: 1.5 revolutions, Maximum: 8.5 revolutions.

### Mark 1 and 4 Transmitter with HART® communication

**Accuracy:** ± 0.5% of full span. Optional ± 0.25% of full span.

**Temperature Limits:** -40 to 176°F (-40 to 80°C). (ATEX flameproof, -B suffix and IECEx flameproof, -IE suffix, rated -40 to 145°F (-40 to 63°C) for switch types A, G, M, O, R, S, V or W, -13 to 145°F (-25 to 63°C) for switch types B, D or I; ATEX intrinsically safe, -IS suffix and IECEx intrinsically safe, -II suffix, rated -40 to 104°F (-40 to 40°C) for switch types O, R, S, V or W; -13 to 104°F (-25 to 40°C) for switch type I.)

**Power Requirements:** 8-30 VDC.

**Current Consumption:** 21 mA.

**Output Signal:** 4-20 mA.

**HART® Receive Impedance:** Rx = 500 kΩ; Cx = 2500 pF.

**Zero and Span Adjustments:** Pushbuttons or HART® communication master for setting both. Mark 1 and 4: Span is adjustable from 0 to 330°. Mark 3: Span is adjustable from 1.5 to 8.5 revolutions.

**Conduit Connection:** 3/4" female NPT standard. Optional one or two 1/2" female NPT. M25 X 1.5 and M20 X 1.5 optional.

**Rotational Travel:** Mark 1 and 4: Maximum: 330°.

### Mark 1 and 4 Transmitter with WirelessHART® communication

**Accuracy:** ±0.5% of full span. Optional ±0.25% of full span.

**Temperature Limits:** -40 to 158°F (-40 to 70°C). (ATEX flameproof, -B suffix and IECEx flameproof, -IE suffix, rated -40 to 145°F (-40 to 63°C). ATEX intrinsically safe, -IS suffix and IECEx intrinsically safe, -II suffix, rated -40 to 176°F (-40 to 80°C).

**Power Requirements:** 8-30 VDC.

**Current Consumption:** 50 mA max.

**Power Output:** +10 dBm (10 mW).

**Operating Frequency:** 2400 to 2483.5 MHz.

**Operating Channels:** 15.

**Sensitivity:** -85dB.

**Zero and Span Adjustments:** Pushbuttons or WirelessHART® communication master for setting both. Span is adjustable from -160 to 160°.

**Conduit Connection:** Two 1/2" female NPT, M20 X 1.5 optional.

**Rotational Travel:** Mark 1 and 4: Maximum: 320°.

## SPECIFICATIONS

### Product Ratings:

Weatherproof and flameproof. NEMA 1, 2, 3, 3R, 3S, 4, 4X, 6, 7, 9, 12, 13.

UL rated: Class I, Div. 1 & 2, Groups B, C, D (Some units available for Group A, consult factory); Class II, Div. 1 & 2, Groups E, F, and G.

CSA rated: Class I, Div. 1 & 2, Groups A, B, C, D; Class II, Div. 1 & 2, Groups E, F, and G. Submersible to 15 meters (IP68); It is up to the end user to source the proper fittings to ensure a watertight seal.

### ATEX Compliant:

-B suffix, any Output Type except 91: Directive 2014/34/EU, KEMA 03ATEX2391 X, CE 0518 Ex II 2G Ex db IIC T6 Gb for -25°C/-40°C/-50°C ≤ Tamb ≤ 63°C and T5 for -25°C/-40°C/-50°C ≤ Tamb ≤ 63°C, optional wording depending on output and switch type selected. Compliant per EN 60079-0:2012+A11:2013 and EN 60079-1:2014.

-B suffix, Output Type 91, with or without -LB suffix: Directive 2014/34/EU, KEMA 03ATEX2391 X, CE 0518 Ex II 2G Ex db ib IIC T4 Gb for -40°C ≤ Tamb ≤ 63°C. Compliant per EN 60079-0:2012 + A11:2013, EN 60079-1:2014 and EN 60079-11:2012.

-IS suffix, any Output Type except 91: Directive 2014/34/EU, KEMA 03ATEX1392 X, CE 0518 Ex II 1G Ex ia IIC T4 Ga. Compliant per EN 60079-0:2012 + A11: 2013 and EN 60079-11:2012.

-IS suffix, Output Type 91, with or without -LB suffix: Directive 2014/34/EU, KEMA 03ATEX1392 X, CE 0518 Ex II 2G Ex ia IIC T4 Ga. Compliant per EN 60079-0:2012+A11:2013 and EN 60079-11:2012.

### IECEx Compliant:

-IE suffix, any Output Type except 91: IECEx DEK 11.0056X Ex db IIC T6 Gb for -25°C/-40°C/-50°C ≤ Tamb ≤ 63°C and T5 for -25°C/-40°C/-50°C ≤ Tamb ≤ 63°C, optional wording depending on output and switch type selected. Compliant per IEC 60079-0:2011 and IEC 60079-1:2014.

-IE suffix, Output Type 91, with or without -LB suffix: IECEx DEK 11.0056X, Ex db ib IIC T4 Gb for -40°C ≤ Tamb ≤ 63°C. Compliant per IEC 60079-0:2011, IEC 60079-1:2014 and IEC 60079-11: 2011.

-II suffix, any Output Type except 91: IECEx DEK 11.0061X Ex ia IIC T4 Ga.

Compliant per IEC 60079-0:2011, IEC 60079-11:2011, and IEC 60079-26:2014.

-II suffix, Output Type 91, with or without -LB suffix: DEK 11.0061X Ex ia IIC T4 Ga. Compliant per IEC 60079-0:2014, and IEC 60079-11:2011.

### INMETRO Compliant:

IM suffix, Certificate: NCC 13.02338 X; Marking: Ex ia IIC T4 Ga

EM suffix, Certificate: NCC 13.02339 X; Marking: Ex d IIC T6 Gb or Ex d IIC T5 Gb

**Electrical Connections:** Screw terminal. Optional factory sealed leads that are 36" (914.4 mm) of 16 AWG.

**Conduit Connection:** Standard: one 3/4" female NPT; optional one to two 1/2" female NPT; WirelessHART® models: two 1/2" female NPT; Optional: M25 X 1.5 or M20 X 1.5 connections may be supplied in lieu of 3/4" and 1/2" female NPT for all models.

**Mounting Orientation:** Not position sensitive.

**Weight:** 4 to 6 lb (1.5 to 3.0 kg).

**Operational Life:** Over 10,000,000 cycles.

**Maximum Altitude:** 2000 meters.

### Mark 1, 3 and 4 with Switch Outputs

**Temperature Limits:** -58 to 176°F (-50 to 80°C). Switch Type C rated to 350°F (176°C) for 600 hours, Switch Type T rated to 250°F (121°C) continuous. (ATEX flameproof, -B suffix and IECEx flameproof, -IE suffix, rated -58 to 145°F (-50 to 63°C) for switch type A, G, H, T, or M, -40 to 145°F (40 to 63°C) for switch type O, R, S, V, or W, -13 to 145°F (-25 to 63°C) for switch type B, D, I, or AS Interface; ATEX intrinsically safe, -IS suffix and IECEx intrinsically safe, -II suffix, rated -13 to 104°F (-25 to 40°C) for switch type D or I, -40 to 104°F (-40 to 40°C) for switch type R, V, or W, or -58 to 104°F (-50 to 40°C) for switch type A, G, or H.)

**Switch Type:** See page reference 1 below.

**Electrical Rating:** See page reference 2 below.

**Set Point Adjustment:** Mark 1 and 4: 5 to 360°.

HART® is a registered trademark of Hart Communication Foundation

1 Switch Type: See page 437 (Series Mark)

2 Electrical Rating: See page 437 (Series Mark)

# VALVE POSITION SENSORS

Dual Inductive, 2-Wire AC/DC Sensor, Fully Adjustable Target in 2° Increments



VPS2411



P1

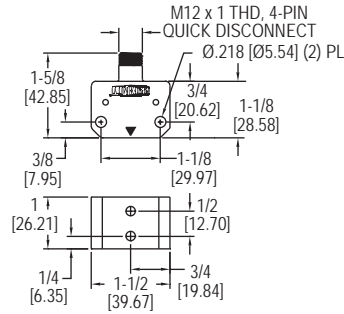

VPS2411

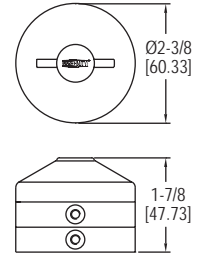

P1

The dual inductive, 2-wire AC/DC **Series VPS Valve Position Sensors** maintain VDI/VDE 3845 dimensions so positioners can be easily mounted on top of the sensor and target. The Model VPS2411 Sensor and Model P1 Target mount easily and directly to actuators with ISO NAMUR topworks (see picture below). Solid state components are fully embedded in an epoxy resin to prevent condensation build-up and to protect against vibration and shock. The rugged PBTP housing provides excellent corrosion resistance and moisture protection.

**FEATURES/BENEFITS**

- Fully adjustable target in 2° increments
- LED indication for visual indication
- 4-pin quick disconnect electrical connection

**APPLICATIONS**

- The VPS is used for control element position monitoring and indication with devices such as rotary valve actuators, rotary valves and dampers.

**SPECIFICATIONS**

**Temperature Limits:** -13 to 176°F (-25 to 80°C).  
**Power Requirements:** 20-140 VAC (50/60 Hz), 10-200 VDC.  
**Enclosure Material:** Polybutylene terephthalate.  
**Switch Type:** Dual NO.  
**Electrical Rating:** 200 mA.  
**Minimum Load Current:** 5 mA.  
**Leakage Current:** 0.8 mA.  
**Voltage Drop:** 5.0 V.  
**Repeatability:** 0.01 mm.  
**Hysteresis:** 3 to 15% of sensing range.  
**Switching Frequency:** 25 Hz.  
**Mounting Holes:** NAMUR mounting - 3.15" x 1.18" (80 x 30 mm) or 5.118" x 1.18" (130 x 30 mm).  
**Electrical Connection:** 4-pin quick disconnect.

MODEL CHART	
Model	Description
VPS2411	Valve position sensor
P1	Valve position target
VIP82	Quick disconnect cable



Model VPS and P1 mounted on an actuator

# DETECTOR POSITION SENSORS

Reliable Magnetic Point Sensor, Stainless Steel Housing, AC or DC

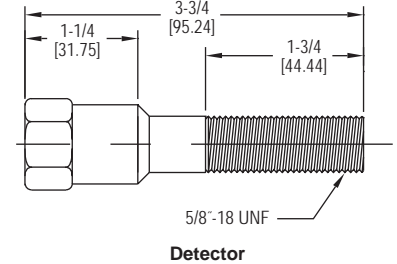
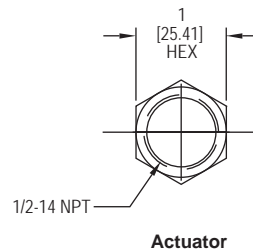

The **Series DT Detector Position Sensors** are reliable, magnetically actuated, SS, completely interchangeable with competitive units. AC or DC for user friendly operation. They have no moving parts, eliminate costly seal fittings and offer enhanced reliability by eliminating arcing. Unintentional actuation by metals is not a problem. The sensor consists of a durable hermetically sealed reed switch potted in a SS housing and a separate 316 SS magnetic actuator bolt. As the actuator moves within the sensing range of the sensor, the magnet in the actuator changes the state of reed switch contacts inside the sensor. This either opens or closes a circuit depending on wiring configuration. Sensing distance is 0.1" (2.54 mm) for the standard target. Greater sensitivity of a larger magnetic target increases the sensing distance to 0.5" (12.7 mm).

#### FEATURES/BENEFITS

- Excellent for hazardous and corrosive environments
- Can be mounted in any position
- Designed to NEMA 1, 3, 4, 4X, 6, 7, 9, 12 and 13

#### APPLICATIONS

- Position monitoring and indication with devices such as linear valves – actuators and cylinders – rotary valves – dampers

#### SPECIFICATIONS

**Temperature Limits:** -40 to 163°F (-40 to 73°C).

**Switch Type:** Tungsten, SPDT, Form C.

**Electrical Rating:** 3 A @ 125 VAC, 3 A @ 30 VDC.

**Enclosure Rating:** Weatherproof; Hermetically sealed; Explosion-proof UL & CSA listed for Class I, Groups A, B, C, & D; Class II, Groups E, F & G. Divisions 1 & 2.

**Intrinsically Safe:** Simple apparatus (w/barrier).

**Operating/Response Time:** 3.0 ms.

Initial Contact Resistance: 0.50 Ω (max).

**Repeatability:** 0.005" (.01 cm).

**Hysteresis:** 0.030" (.08 cm).

**Electrical Connection:** Factory sealed leads with 18" min, 4 conductor, PVC insulated, 18 AWG – green/red/black/white (ground/NC/ NO/common).

**Housing:** 316 SS.

**Potting:** Epoxy resin.

**Conduit:** 1/2"-14" female NPT.

**Weight:** 0.32 lb (145 g); 0.45 lb (204 g) with actuator.

**Agency Approvals:** CSA, cULus.

#### MODEL CHART

Model	Description	Sensing Distance
DT1060	Detector and standard actuator	0.1" (2.54 mm)
DT1160	Detector and high strength actuator	0.5" (12.7 mm)



# ELECTRO-PNEUMATIC TRANSDUCERS

Low Cost, Selectable Input/Output, Manual Override



EPTA-B



EPTA-S

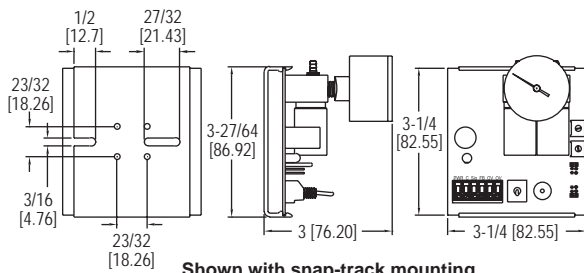

Shown with snap-track mounting

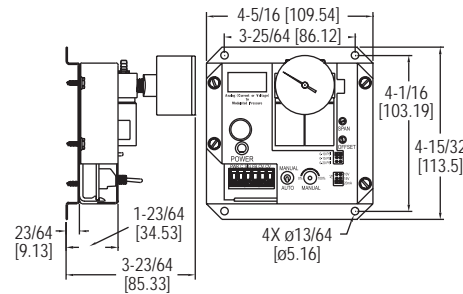

Shown with metal bracket mounting

The Series EPTA Electro-Pneumatic Transducers convert an analog input signal to a linearly proportionate pneumatic output by modulating its control valves to regulate branch line pressure to the set point determined by the input signal. All models incorporate two low voltage valves, an integral in-barb filter, a 0 to 30 psi analog gage, an anodized aluminum manifold, and brass barbed fittings. The EPTA offers adjustable span and offset as well as manual override. This unit has no air consumption and is immune to mounting orientation. Output pressure ranges include field-selectable 0 to 10, 0 to 15, and 0 to 20 psig. Also included is an analog 0 to 5 VDC feedback signal indicating the resultant branch line pressure. Universal 24 VAC/24 VDC supply voltage and field-selectable 4-20 mA, 0-5 VDC, 0-10 VDC, or 0-15 VDC inputs ensure single unit compatibility with most systems. The standard models maintain branch pressure on power loss while the Fail-Safe models will drop the branch pressure to 0 psi on power loss. Mounting configurations include a metal bracket mount in the EPTA-B models and a snap-track mount in the EPTA-S models. The A-400 accessory kit will allow the EPTA-S models to be mounted on a standard DIN rail.

**FEATURES/BENEFITS**

- Adjustable span and offset
- Manual override
- Field selectable output ranges
- Not position sensitive

**APPLICATIONS**

- Pneumatic dampers and valve actuators

**SPECIFICATIONS**

**Service:** Clean dry air or any inert gas.  
**Input Signal:** DC current (4-20 mA) or DC voltage (0-5/0-10/0-15).  
**Input Impedance:** Current: 250 Ω; Voltage: Infinite.  
**Output Signal:** Jumper selectable 0 to 10 psig (0 to 69 kPa), 0 to 15 psig (0 to 103 kPa), or 0 to 20 psig (0 to 138 kPa).  
**Feedback Output:** 0-5 VDC.  
**Air Supply:** 25 psig (172 kPa) max.  
**Air Flow:** 750 scim.  
**Air Consumption:** 0 scim normal operation, fail-safe model vents to 0 psi on power loss.  
**Accuracy:** ±1.0% FS @ room temperature; ±2.0% FS @ 32 to 120°F (0 to 48.8°C).

**Supply Voltage:** 24 VDC (+10%/-5%) or 24 VAC (±10%) 50/60 Hz.  
**Supply Current:** 180 mA max, 200 mA max on fail-safe model.  
**Temperature Limits:** Operating: 32 to 120°F (0 to 48.8°C); Storage: -20 to 150°F (-6.7 to 65.6°C).  
**Operating Humidity Range:** 5 to 95%, non-condensing.  
**Pressure Connections:** 1/4" OD (polyethylene tubing optimum).  
**Electrical Connections:** Plug-in block terminal type with 5 mm pin spacing.  
**Wire Size:** Up to one 14 AWG per terminal.  
**Weight:** EPTA-S0: 6.9 oz. (196 g); EPTA-S1: 9.2 oz. (261 g); EPTA-B: 14.5 oz. (411 g).

**ACCESSORIES**

Model	Description
A-400	DIN mounting kit
A-403	Replacement integral barb filter

USA: California Proposition 65  
 ⚠WARNING: Cancer and Reproductive Harm - www.P65Warnings.ca.gov

MODEL CHART	
Model	Description
EPTA-S0	Standard snap-track mount transducer
EPTA-B0	Standard metal bracket mount transducer
EPTA-S1	Snap-track mount transducer with fail-safe
EPTA-B1	Metal bracket mount transducer with fail-safe

# CURRENT TO PRESSURE TRANSDUCER

Intrinsically Safe, NEMA 4X Enclosure, Field Reversible, Low Cost

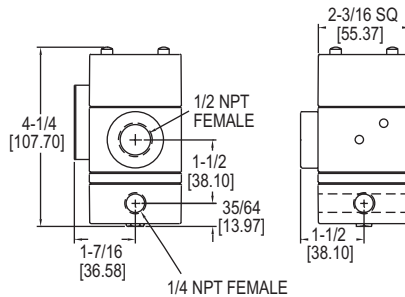

The Series IP Current to Pressure Transducer converts a current input signal to a linearly proportional pneumatic output pressure. The features include built-in volume booster, low air consumption, field reversible (provides output which is inversely proportional to input signal) and flexible zero and span adjustments. The rugged NEMA 4X enclosure allows splashdown and outdoor installation. The IP can be used for applications that require operation of valve actuators, pneumatic valve positioners, damper and louver actuators, final control elements and relays.

**FEATURES/BENEFITS**

- Built-in volume booster
- Low air consumption
- Flexible zero plus span adjustments
- NEMA 4X enclosure
- Field reversible

**APPLICATIONS**

- Applications that require the operation of valve actuators, pneumatic valve positioners, damper and louver actuators, final control elements, relays, air cylinders, web tensioners, clutches and brakes

**SPECIFICATIONS**

**Service:** Oil free, clean dry air filtered to 40 microns.  
**Input Signal:** 4-20 mA.  
**Input Impedance:** IP-42: 180 ohms; IP-43 and IP-44: 220 Ω.  
**Air Pressure:** Min: 3 psig (21 kPa) above max output; Maximum: 100 psig (700 kPa).  
**Linearity:** < ±0.75% of span.  
**Hysteresis:** < 1% of span.  
**Repeatability:** < 0.5% of span.  
**Supply Pressure Sensitivity:** < ±0.1% of span per psig (< ±0.15% of span per 10 kPa).  
**Power Requirements:** Loop-powered.  
**Temperature Limits:** -20 to 140°F (-30 to 60°C).  
**Pressure Connections:** 1/4" female NPT.  
**Electrical Connection:** 1/2" female NPT.  
**Air Consumption:** 0.03 SCFM (0.5 m³/h) typical.  
**Output Capacity:** 4.5 SCFM (7.6 m³/h ANR) at 25 psig (175 kPa) supply; 12 SCFM (20 m³/h) at 100 psig (700 kPa) supply.  
**Relief Capacity:** 2 SCFM (3.4 m³/h) at 5 psig (35 kPa) above 20 psig (140 kPa) set point.  
**Weight:** 2.1 lb (0.94 kg).  
**Agency Approvals:** CE, FM.

MODEL CHART			
Model	Input Ranges	Output Range	
		psi	kPa
IP-42	4-20 mA	3 to 15	20 to 100
IP-43	4-20 mA	3 to 27	20 to 185
IP-44	4-20 mA	6 to 30	40 to 200



# CURRENT TO PRESSURE TRANSDUCER

## NEMA 4X Enclosure, Compact Size, Reliable

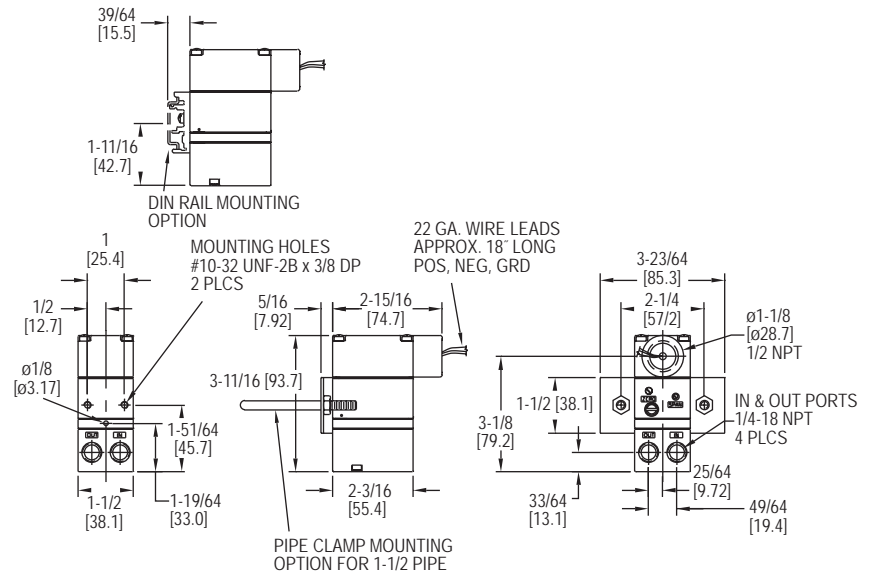

The **Series 2700 Current to Pressure Transducer** combines economical startup cost, low air consumption, and reliable performance to make the 2700 a great investment. The unit converts a variable current signal to a proportional pneumatic output. It has input and output ports on both the front and back which allows for versatile plumbing. The NEMA 4X enclosure enables the unit to be installed indoors or outdoors, however, the unit is not vibration resistant. It is FM and CSA approved for intrinsically safe operation. The 2700 is designed for remote or panel mounting. An integral volume booster provides high flow capacity, increasing control speed in critical applications. Other features include external zero and span adjustments which are convenient for field calibration.

The **Series 2800 Current to Pressure Transducer** utilizes a closed loop pressure feedback system that closely controls output and compensates for vibration, mounting angle, temperature, and supply pressure variations. These characteristics make this unit ideal for field mounting on a valve. The control mechanism is a piezoceramic actuator encapsulated in a protective skin, which provides a constant defense against humidity and contaminants. These features make this unit ideal for use in demanding applications. The 2800 also comes in a NEMA 4X enclosure and is field reversible. It is FM and CSA approved intrinsically safe, as well. For ease of installation, this model has input and output ports on both the front and back and can be easily panel mounted.

### SERIES 2700 FEATURES/BENEFITS

- NEMA 4X enclosure
- FM and CSA approved for intrinsically safe
- Designed for remote or panel mounting
- Integral volume booster

### APPLICATIONS

- Controlling valve actuators, pneumatic valve positioners, air cylinders, clutches, brakes, dampers, louvers and pumps

### SERIES 2800 FEATURES/BENEFITS

- NEMA 4X enclosure
- FM and CSA approved for intrinsically safe
- Vibration and position insensitive
- Input and output ports on front and back

### MODEL CHART

Model	Input	Output
2713-WP	4-20 mA	3 to 15 psig (0.2 to 1.0 bar)
2716-WP	4-20 mA	6 to 30 psig (0.4 to 2.1 bar)
2813-WP	4-20 mA	3 to 15 psig (0.2 to 1.0 bar)
2816-WP	4-20 mA	6 to 30 psig (0.4 to 2.1 bar)

### ACCESSORIES

Model	Description
A-180	Valve mounting bracket, for Hi-Flow™ control valves (Series 2800 only)
A-181	DIN rail mounting kit, suitable for EN-50035, EN-50042, and EN-50022 rails
A-182	Pipe mounting kit, for 1-1/2 and 2" pipes

### SPECIFICATIONS

**Service:** Oil free, clean dry air filtered to 40 microns.  
**Input Signal:** 4-20 mA.  
**Air Supply:** Min: 5 psig (0.3 bar) above max output; Max: 100 psig (6.9 bar).  
**Output:** 3 to 15 psig (0.2 to 1.0 bar), 6 to 30 psig (0.4 to 2.1 bar).  
**Accuracy:** Series 2800:  $\pm 0.1\%$  of span.  
**Linearity:** Series 2700:  $< \pm 0.5\%$  of span.  
**Hysteresis:** Series 2700:  $< 0.5\%$  of span; Series 2800:  $\pm 0.1\%$  of span.  
**Repeatability:** Series 2700:  $< 0.5\%$  of span; Series 2800:  $\pm 0.1\%$  of span.  
**Deadband:** Series 2800: 0.02% of span.  
**Supply Pressure Sensitivity:** Series 2700:  $< 0.1\%$  of span per 1.0 psig (0.1 bar).  
**Power Requirement:** Loop powered.  
**Temperature Limits:** Series 2700: -20 to 150°F (-29 to 66°C); Series 2800: Operating: -40 to 160°F (-40 to 71°C); Storage: -40 to 200°F (-40 to 93°C).  
**Pressure Connections:** 1/4" female NPT.  
**Electrical Connection:** 1/2" female NPT.  
**Air Consumption:** Series 2700: 0.03 scfm (0.01 l/s) at midrange typical; Series 2800: 0.025 scfm (0.01 l/s) at midrange typical.  
**Output Capacity:** 4.5 scfm (2.1 l/s) at 25 psig (1.7 bar) supply; 12.0 scfm (5.7 l/s) at 100 psig (6.9 bar) supply.  
**Enclosure:** Chromate-treated aluminum with epoxy paint.  
**Enclosure Rating:** NEMA 4X (IP66) and intrinsically safe.  
**Weight:** Series 2700: 1.3 lb (0.59 kg); Series 2800: 0.8 lb (0.37 kg).  
**Agency Approvals:** CE, CSA, FM.

### SERIES 2700

**FM Intrinsically Safe Ratings:** Class I, II, III, Division 1, Groups C, D, E, F and G; Class I, Division 2, Groups A, B, C and D; Class II and III, Division 2, Groups F and G.  
**CSA Intrinsically Safe Ratings:** Class I, Division 2, Groups C and D; Class II, Groups E, F and G; Class III.

### SERIES 2800

**FM Intrinsically Safe Ratings:** Class I, II, and III, Division 1, Groups C, D, E, F, and G; Class I, Zone 0, Group IIB; Class I, II, and III, Division 2, Groups A, B, C, D, F, and G.  
**CSA Intrinsically Safe Ratings:** Class I, Division 2, Groups A, B, C and D; Class II, Division 2, Groups F and G; Class III.

### OPTIONS

Description
Valve mount, for factory mounting and calibration to Hi-Flow™ control valves, add current-to-pressure transducer model number as suffix (Series 2800 only)

# CURRENT TO PRESSURE TRANSDUCER

Intrinsically Safe, Explosion-Proof, NEMA 4X Enclosure

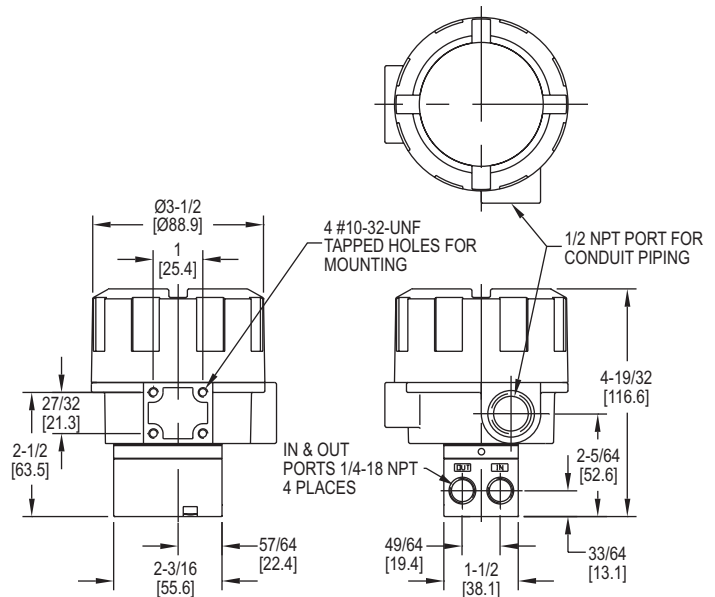

The **Series 2900 Current to Pressure Transducer** delivers reliable high performance for the toughest applications in the most hazardous environments. Its NEMA 4X housing is designed and FM and CSA approved for both intrinsically safe and explosion-proof operation. This unit has advanced circuitry which includes electronic feedback control for superior vibration protection and highly accurate output. The 2900 is not position sensitive and the easily accessible zero and span adjustments make field calibration quick and easy. For ease of installation, this model has input and output ports on both the front and back. It is also not vibration sensitive, which makes the 2900 ideal for field mounting on a valve. These features coupled with the unit's compact size help make set-up and installation simple.

**FEATURES/BENEFITS**

- Designed for hazardous environments
- Vibration resistant
- Explosion-proof
- Weatherproof and intrinsically safe

**APPLICATIONS**

- Controlling valve actuators, pneumatic valve positioners, air cylinders, clutches, brakes, dampers, louvers and pumps

MODEL CHART		
Model	Input	Output
2913-E	4 to 20 mA	3-15 psig (0.2-1.0 bar)
2916-E	4 to 20 mA	6-30 psig (0.4-2.1 bar)

ACCESSORIES	
Model	Description
A-180	Valve mounting bracket, for Hi-Flow™ control valves (Series 2800 only)

OPTIONS	
Description	
Valve mount, for factory mounting and calibration to Hi-Flow™ control valves, add current-to-pressure transducer model number as suffix (Series 2800 only)	

**SPECIFICATIONS**

**Service:** Oil free, clean dry air filtered to 40 microns.  
**Input Signal:** 4-20 mA.  
**Air Supply:** Min: 5 psig (0.3 bar) above max output; Max: 100 psig (6.9 bar).  
**Output:** 3 to 15 psig (0.2 to 1.0 bar), 6 to 30 psig (0.4 to 2.1 bar).  
**Accuracy:** ±0.1% of span.  
**Hysteresis:** ±0.1% of span.  
**Repeatability:** ±0.1% of span.  
**Deadband:** 0.02% of span.  
**Power Requirement:** Loop powered.  
**Temperature Limits:** Operating: -40 to 160°F (-40 to 71°C); Storage: -40 to 200°F (-40 to 93°C).  
**Pressure Connections:** 1/4" female NPT.  
**Electrical Connection:** 1/2" female NPT.  
**Air Consumption:** 0.05 scfm (0.02 l/s) at midrange typical.  
**Output Capacity:** 4.5 scfm (2.1 l/s) at 25 psig (1.7 bar) supply; 12.0 scfm (5.7 l/s) at 100 psig (6.9 bar) supply.  
**Enclosure:** Chromate-treated aluminum with epoxy paint.  
**Enclosure Rating:** Weatherproof NEMA 4X (IP66), explosion-proof and intrinsically safe.  
**Weight:** 1.8 lb (0.82 kg).  
**Agency Approvals:** CE, CSA, FM.

**FM Ratings:** Explosion-proof for Class I Division 1, Groups B, C, and D, T6, Dust Ignitionproof for Class I, Division 1, Groups E, F, and G, T6; Intrinsically safe for Class I, II, and III, Division 1, Groups C, D, E, F, and G, T4 hazardous (classified) locations and intrinsically safe for Class I, Zone 0, Group IIB, T4 hazardous (classified) locations and suitable for Class I, Groups A, B, C, D, T4, and Class II and III, Division 2, Groups F and G, T6 hazardous (classified) locations.

**CSA Ratings:** Class I Division 1, Groups B, C, and D; Class I, Division 2, Groups A, B, C and D; Class II, Division 1, Groups E, F, and G; Class II and III, Division 2, Groups F and G.

# PRECISOR® II PNEUMATIC AND ELECTRO-PNEUMATIC POSITIONERS

Linear Operation, Field Selectable Cam Design, 316 SS Models

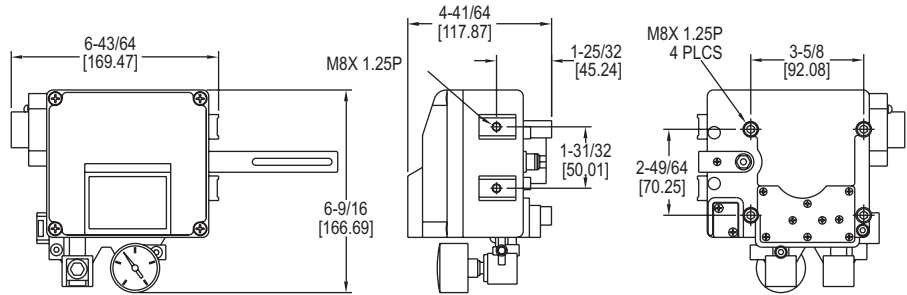

Series 165NL

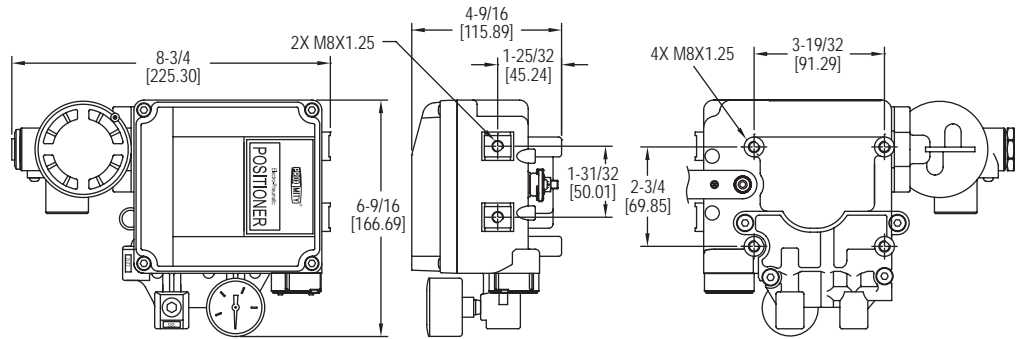

Series 165EL

The Series 165 PRECISOR® II Pneumatic and Electro-Pneumatic Positioners deliver stable process control at an exceptionally low price. Its rugged, durable design makes it ideal for harsh environments while maintaining precise, accurate positioning of the control element. Units can be easily changed from direct to reverse action, or vice versa. Low air consumption keeps operating costs at a minimum, while still responding quickly and accurately. Excellent for use in chemical processing, food and beverage, pulp and paper, and pharmaceutical industries, as well as many others.

## FEATURES/BENEFITS

- Field selectable cam for direct or reverse acting

## APPLICATIONS

Series 165 PRECISOR® II Pneumatic and Electro-Pneumatic Positioners provide excellent modulating control when used between the Dwyer Temperature Controllers, Current to Pressure Transducer, and the Hi-Flow™ Valve in such industries as the food and beverage processing, chemical, pharmaceutical, and wood pulp and paper.

## HOW TO ORDER:

1. Select Model No. to specify input control signal.
2. For proper mounting hardware, order according to which actuator the positioner will be mounted to.

MODEL CHART		
Model	Input	Enclosure
165NL	3 to 15 psig	Aluminum
165EL	4-20 mA	Aluminum
165EL-SS	4-20 mA	Stainless steel

ACCESSORIES - MOUNTING KITS	
Model	For Actuator Models
A-233	220 and 221 air-to-lower
A-234	222 and 223 air-to-lower
A-235	230 and 231 air-to-raise
A-236	233 air-to-raise

## SPECIFICATIONS

**Input Signal:** Pneumatic: 3 to 15 psig (0.2 to 1 bar); Electro-pneumatic: 4 to 20 mA DC.

**Input Impedance:** (165EL only): 250 ±15 Ω.

**Enclosure Material:** Aluminum diecasting or 316 SS.

**Air Supply:** 20 to 100 psig (1.4 to 6.9 bar).

**Air Supply Connection:** 1/4" NPT.

**Gage Connection:** 1/8" NPT.

**Electrical Connection:** Screw terminal.

**Conduit Connection:** 1/2" NPT (165EL only).

**Linearity:** ±0.2% FS.

**Hysteresis:** 1% FS.

**Sensitivity:** ±0.2% FS.

**Repeatability:** ±0.5% FS.

**Air Consumption:** 0.10 scfm (3 LPM) at 20 psig (1.4 bar) supply.

**Flow Capacity:** 28 scfm (80 LPM) at 20 psig (1.4 bar) supply.

**Stroke:** 0.5 to 6" (10 to 150 mm).

**Enclosure Rating:** IP66 (NEMA 4X).

**Temperature Limits:** Aluminum: -4 to 158°F (-20 to 70°C); SS: -40 to 158°F (-40 to 70°C).

**Weight:** 165NL: 3.1 lb (1.7 kg); 165EL: 6.1 lb (2.7 kg).

**Agency Approvals:** CE (165EL only).

## OPTIONS

### Description

Valve mount, for factory mounting and calibration to Hi-Flow™ control valves, add suffix to valve model number of positioner.  
(Does not include valve or positioner piece)

**Example:** 2004VA32-231-165EL



# PRECISOR® II PNEUMATIC AND ELECTRO-PNEUMATIC POSITIONERS

Rotary Operation, Field Selectable Cam Design, 316 SS Models

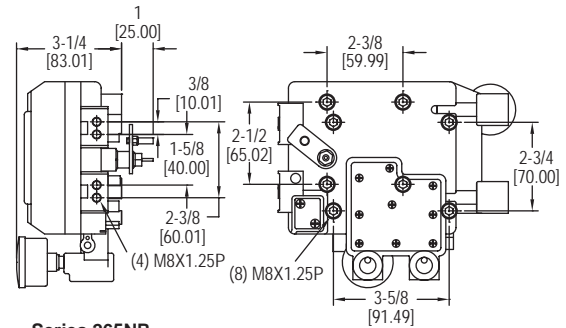
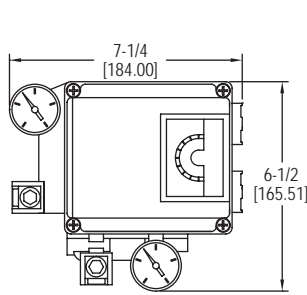

Series 265NR

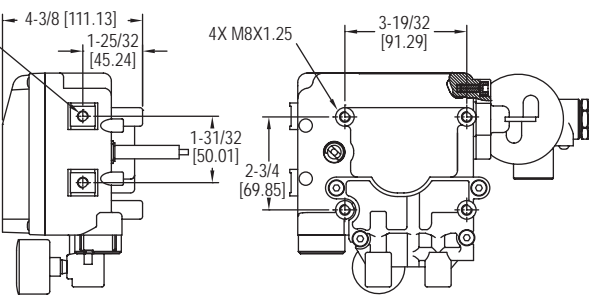
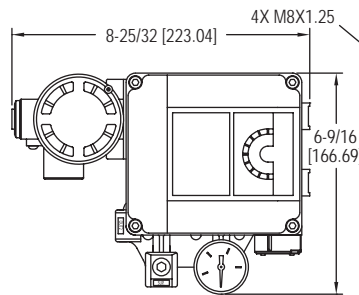

Series 265ER

Proximity **Series 265 Precisor® II Pneumatic and Electro-Pneumatic Positioners** combine outstanding performance with an extremely low price, making it an exceptional value for industrial applications. Rotary valves with single or double acting pneumatic actuators can be precisely controlled, such as our ball and butterfly valves. The Precisor® II positioner proportionally modulates the valve from either an electric 4 to 20 mA or pneumatic 3 to 15 psig input signal, based on the model chosen and is user-selectable for single or double action. Its rugged, durable design makes it ideal for use in harsh environments, while maintaining precise, accurate positioning of the control elements. Includes a bracket for mounting onto actuators with NAMUR standard connections, and features a versatile linear cam for direct action, reverse action, or split ranges.

**FEATURES/BENEFITS**

- Field selectable cam for direct or reverse acting
- User selectable for single or double action
- Highly visible indicator for local indication
- IP66 enclosure rating

**APPLICATIONS**

- Rotary valves with single or double acting pneumatic actuators

MODEL CHART			
Model	Input	Lever Type	Enclosure
265NR-D5	3 to 15 psig	NAMUR	Aluminum
265ER-D5	4-20 mA	NAMUR	Aluminum
265ER-D5SS	4-20 mA	NAMUR	Stainless steel

ACCESSORIES	
Model	Description
A-228	SS steel flex hose, 12" (30.48 cm) L, 1/8" male NPT connections
A-332	Brass adapter, 1/8" female NPT to 1/4" male NPT

**SPECIFICATIONS**

**Input Signal:** Pneumatic: 3 to 15 psig (0.2 to 1 bar); Electro-pneumatic: 4-20 mA DC.  
**Input Impedance:** (265ER only): 250 ±15 Ω.  
**Enclosure Material:** Aluminum diecasting or 316 SS.  
**Air Supply:** 20 to 101 psig (1.4 to 7.0 bar).  
**Air Supply Connection:** 1/4" NPT.  
**Gage Connection:** 1/8" NPT.  
**Electrical Connection:** Screw terminal.  
**Conduit Connection:** 1/2" NPT (265ER only).  
**Linearity:** ±2% FS.  
**Hysteresis:** 1% FS.  
**Sensitivity:** ±0.5% FS.  
**Repeatability:** ±0.5% FS.  
**Air Consumption:** 0.10 scfm (3 LPM) at 20 psig (1.4 bar) supply.  
**Flow Capacity:** 28 scfm (80 LPM) at 20 psig (1.4 bar) supply.  
**Stroke:** 0 to 90°.  
**Enclosure Rating:** IP66.  
**Temperature Limits:** -4 to 158°F (-20 to 70°C).  
**Weight:** 265NR: 3.1 lb (1.7 kg); 265ER: 6.2 lb (2.8 kg).  
**Agency Approvals:** CE (265ER only).



**Pneumatic hosing and fittings**

Hosing and fittings for connecting positioners, current to pressure transducers, air filter gauges and other accessories to pneumatic actuated valves.

USA: California Proposition 65  
 ⚠️WARNING: Cancer and Reproductive Harm - www.P65Warnings.ca.gov

Filters and Regulators: See pages 447-448



SERIES 185 & 285 | PROXIMITY® BY DWYER



# LINEAR AND ROTARY SMART POSITIONERS

Fail Freeze, Linear and Rotary Operation, HART® Communication

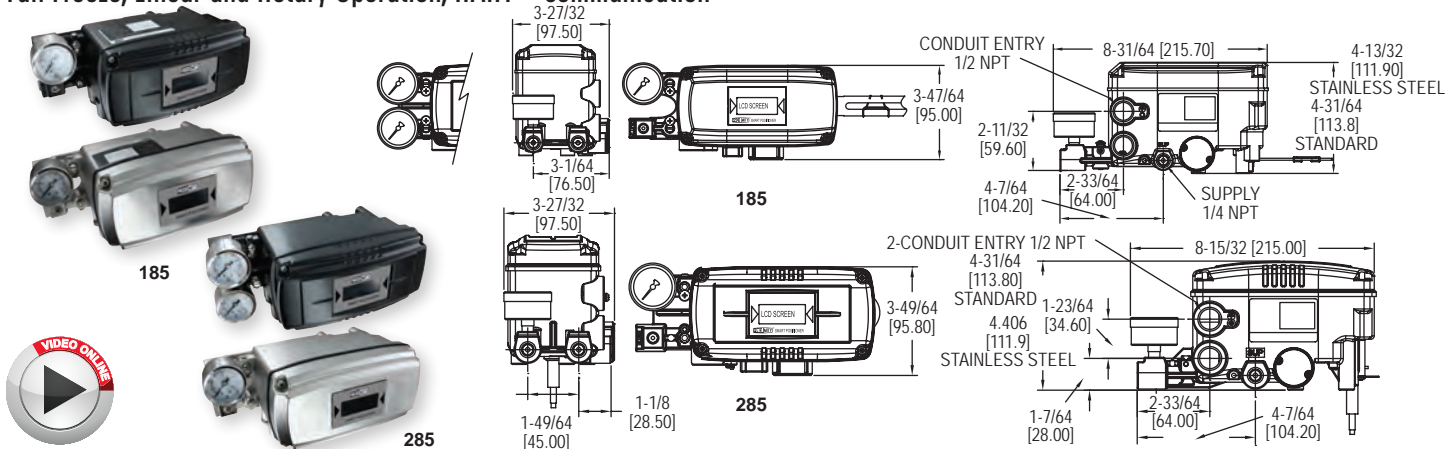

Proximity Series 185 & 285 Linear and Rotary Smart Positioners combine an easy to use, high performance unit with a low price. Series 185 models accurately control the valve stroke of linear motion valves and Series 285 models accurately control the valve stroke of rotary motion valves. An analog feedback signal is outputted to stabilize any valve system, and easy to use functions such as auto calibration ensure the accuracy of the unit. The compact design of this unit makes it easy to use with any size actuator. Smart Positioners feature a LCD screen attached to the outer surface of the unit, allowing for an easy inspection of the positioner condition while in the field. Available in user selectable single or double action, with HART® communication as standard. In the event that the 4-20 mA input signal is lost the 185 and 285 will fail in place.

MODEL CHART		
Model	Communication	Enclosure
185EL-D1	HART®	Aluminum
185EL-D1SS	HART®	SS
285ER-D5	HART®	Aluminum
285ER-D5SS	HART®	SS

**FEATURES/BENEFITS**

- User selectable single or double action
- LCD display

**APPLICATIONS**

- Linear motion valves or rotary motion valves with single or double acting actuators

**SPECIFICATIONS**

**Input Signal:** 4-20 mA DC.  
**Input Impedance:** 460 Ω max @ 20 mA DC.  
**Enclosure Material:** Aluminum or 316 SS.  
**Air Supply:** 35 to 116 psi (2.4 to 8 bar).  
**Air Connection:** 1/4" NPT.  
**Gage Connection:** 1/8" NPT.  
**Conduit Connection:** 1/2" NPT.  
**Linearity:** ±0.5% FS.  
**Hysteresis:** ±0.5% FS.  
**Sensitivity:** ±0.2% FS.

**Repeatability:** ±0.3% FS.  
**Air Consumption:** .0004 scfm (.01 LPM) at 20 psig (1.4 bar) supply.  
**Flow Capacity:** 2.1 scfm (60 LPM) at 20 psig (1.4 bar) supply.  
**Stroke:** 0.5 to 6" (10 to 150 mm) or 0 to 90°.  
**Enclosure Rating:** NEMA 4X (IP66).  
**Temperature Limits:** -22 to 185°F (-30 to 85°C).  
**Weight:** 3.3 lb (1.5 kg); SS models: 6.4 lb (2.9 kg).

HART® is a registered trademark of Hart Communication Foundation

Filters and Regulators: See pages 447-448

SERIES 195 & 295 | PROXIMITY® BY DWYER



# COMPACT LINEAR AND ROTARY SMART POSITIONERS

Low Cost, Rotary Operation, HART® Communication

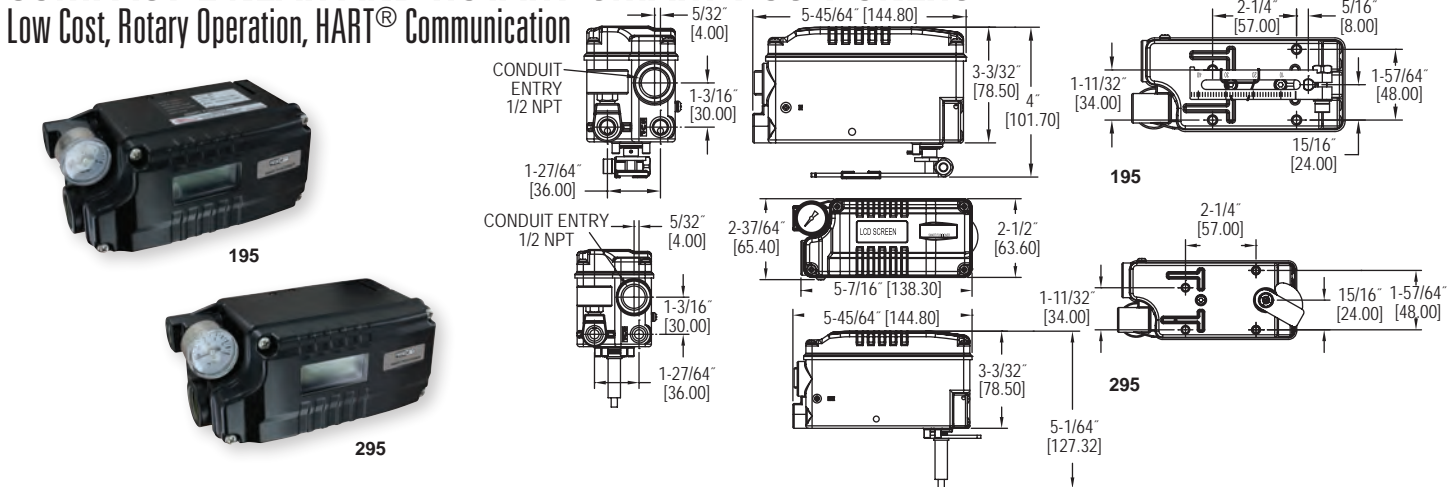

Proximity Series 195 & 295 Compact Linear and Rotary Smart Positioners are compact, high performance units with a low price. Series 195 models accurately control the valve stroke of linear motion valves and Series 295 models accurately control the valve stroke of rotary motion valves. An analog feedback signal is outputted to stabilize any valve system, and easy to use functions such as auto calibration ensure the accuracy of the unit. The handheld size of this unit makes it easy to use with any size actuator, and can be used in applications where a larger positioner may not fit. Series 195 and 295 Smart Positioners feature a LCD screen attached to the outer surface of the unit, allowing for an easy inspection of the positioner condition while in the field. Available with HART® communication.

MODEL CHART		
Model	Action	Communication
195EL-S1	Single	None
195EL-S2	Single	HART®
295ER-S1	Single	None
295ER-S2	Single	HART®

**FEATURES/BENEFITS**

- LCD Display
- Auto calibration, PID control and alarm

**APPLICATIONS**

- Linear motion valves or rotary motion valves with single acting actuators

**SPECIFICATIONS**

**Input Signal:** 4-20 mA DC.  
**Input Impedance:** 460 Ω max @ 20 mA DC.  
**Enclosure Material:** Aluminum.  
**Air Supply:** 35 to 116 psi (2.4 to 8 bar).  
**Air Connection:** 1/4" NPT.  
**Gage Connection:** 1/8" NPT.  
**Conduit Connection:** 1/2" NPT.  
**Linearity:** ±0.5% FS.  
**Hysteresis:** ±0.5% FS.  
**Sensitivity:** ±0.2% FS.

**Repeatability:** ±0.3% FS.  
**Air Consumption:** .0004 scfm (.01 LPM) at 20 psig (1.4 bar) supply.  
**Flow Capacity:** .32 scfm (9 LPM) at 20 psig (1.4 bar) supply.  
**Stroke:** 0.19 to 1.38" (5 to 35 mm) or 0 to 90°.  
**Enclosure Rating:** NEMA 4X (IP66).  
**Temperature Limits:** -22 to 185°F (-30 to 85°C).  
**Weight:** 1.8 lb (.82 kg).

HART® is a registered trademark of Hart Communication Foundation

Filters and Regulators: See pages 447-448

# VOLUME BOOSTERS

Economical, 1:1 Ratio

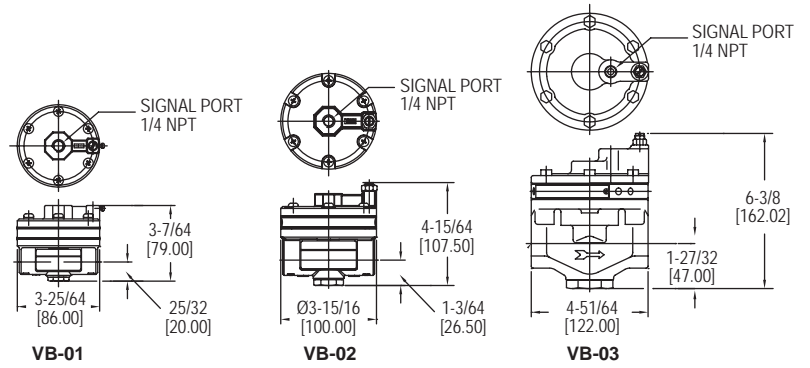

The **Series VB Volume Boosters** are a one to one signal to output relay and an ideal solution to increasing valve stroke speed. A large input signal change to the booster delivers high volume for quick throttling control. Volume booster responds to the slightest changes in input signal, which in turn increases accuracy of the output of air pressure to the actuator. This booster receives the positioner's signal output and supplies the proper air pressure to the actuator to reduce response and adjustment time. Available in aluminum or stainless steel.

**FEATURES/BENEFITS**

- Responds to the slightest change in input signal
- Supplies constant air pressure at a 1:1 ratio

**APPLICATIONS**

- Used with pneumatic control valves

**SPECIFICATIONS**

**Service:** Air only.  
**Wetted Materials:** Body: Aluminum or SS; Diaphragm: Nitrile elastomer.  
**Max Supply Pressure:** 145 psi (10 bar).  
**Max Signal/Output Pressure:** 101.5 psi (7 bar).  
**Signal Connection:** 1/4" NPT.  
**In/Output Pressure Ratio:** 1:1.  
**Temperature Limits:** -4 to 158°F (-20 to 70°C).  
**Linearity:** ±1% FS.  
**In/Output Connection:** See model chart.  
**Weight:** See model chart.

**MODEL CHART**

Model	Cv	Weight	In/Out Connection	Construction
VB-01	1.02	1.1 lb (0.5 kg)	1/4" NPT	Aluminum
VB-01SS	1.02	2.9 lb (1.3 kg)	1/4" NPT	SS
VB-02	2.32	1.7 lb (0.76 kg)	1/2" NPT	Aluminum
VB-02SS	2.32	4.2 lb (1.9 kg)	1/2" NPT	SS
VB-03	4.98	5.1 lb (2.3 kg)	3/4" NPT	Aluminum
VB-03SS	4.98	11 lb (5 kg)	3/4" NPT	SS

# MINIATURE PRESSURE REGULATOR

Air or Water Regulator, Compact and Lightweight, Low Cost

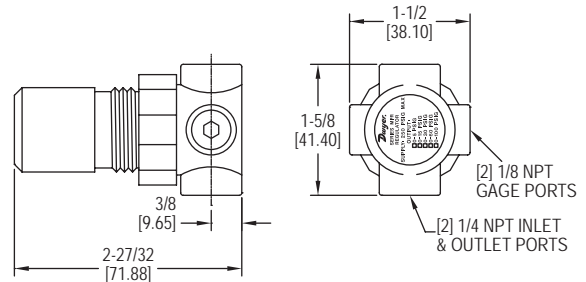

The **Series MPR Miniature Pressure Regulator** is a compact unit that provides low cost, high performance pressure regulation of compressed air or air/water. The low torque, non-rising adjustment knob with locking capability provides easy and precise adjustment. Models for use with air are self relieving. Models for air/water are non-relieving.

**FEATURES/BENEFITS**

- Low cost
- Easy and precise adjustment
- Compact

**APPLICATIONS**

- Any industrial application that requires water or air pressure regulations and low cost

**SPECIFICATIONS**

**Service:** Compressed air or water.  
**Wetted Materials:** Body: Zinc; Bonnet: Acetal; Diaphragm/seals: Nitrile; Internals: Aluminum, brass, acetal, steel, music wire (MPR2 is plated with electroless nickel for water use).  
**Maximum Supply Pressure:** 250 psig (17.2 bar).  
**Temperature Limits:** 0 to 150°F (-18 to 60°C).  
**Flow Capacity:** 24 SCFM (48 m3/hr) at 100 psig (6.9 bar) supply, 60 psig (4.1 bar) output.  
**Process Connection:** Inlet and outlet: Two 1/4" female NPT; Two 1/8" female NPT gage ports.  
**Weight:** 4 oz (113 g).

**ACCESSORIES**

Model	Description
MPR-B	Mounting bracket
MPR-N	Panel mounting nut

USA: California Proposition 65  
 ⚠️WARNING: Cancer and Reproductive Harm - www.P65Warnings.ca.gov

MODEL CHART		
Air Model	Air/Water Model	Range
MPR1-0	MPR2-0	0 to 5 psi
MPR1-1	MPR2-1	0 to 15 psi
MPR1-2	MPR2-2	0 to 30 psi
MPR1-3	MPR2-3	0 to 60 psi
MPR1-4	MPR2-4	0 to 100 psi

**Dwyer**  
SERIES AFR

## AIR FILTER REGULATOR

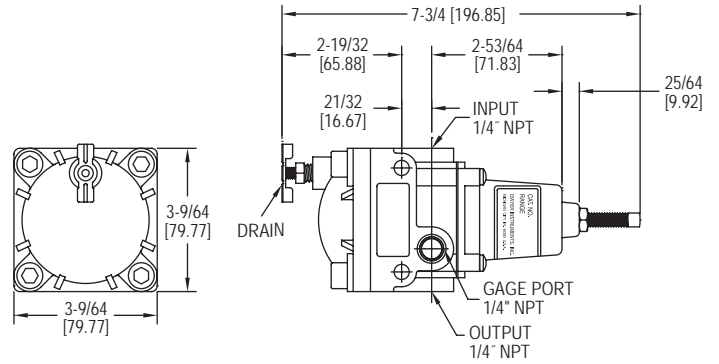

**Series AFR Air Filter Regulator** provides clean air pressure to pneumatic controllers, valve positioners, air cylinders and other equipment. Self-relieving regulator is equipped with a 40 micron filter housed in a dripwell with gage port.

### FEATURES/BENEFITS

- Stable output
- Low air consumption
- 40 micron filter

### APPLICATIONS

- Provides clean, accurate air pressure to pneumatic controllers, valve positioners, air cylinders and other equipment

### MODEL CHART

Model	Range
AFR1	0 to 10 psi (0 to 65 kPa)
AFR2	0 to 30 psi (0 to 200 kPa)
AFR3	0 to 60 psi (0 to 400 kPa)
AFR4	0 to 120 psi (0 to 800 kPa)

### SPECIFICATIONS

**Service:** Air only.

**Wetted Materials:** Body: Aluminum alloy, irridite, and lock epoxy finish; Filter: Phenolic impregnated cellulose; Diaphragm and valve seat plug: Nitrile elastomer.

**Max. Supply Pressure:** 250 psig (1700 kPa).

**Temperature Limits:** 0 to 160°F (-18 to 71°C).

**Sensitivity:** 1" (2.5 cm) of water.

**Consumption:** <6 SCFH (0.17 m<sup>3</sup>/hr).

**Flow Capacity:** 20 SCFM (33 m<sup>3</sup>/hr) @ 100 psig (700 kPa) supply.

**Exhaust Capacity:** 0.1 SCFM (0.17 m<sup>3</sup>/hr) with downstream pressure 5 psig (35 kPa) above set point.

**Process Connection:** 1/4" female NPT.

**Weight:** 1.6 lb (725 g).

### ACCESSORIES

Model	Description
AFR-BRKT	Mounting bracket

### SERIES AFR2 | PROXIMITY® BY DWYER

## INSTRUMENT AIR FILTER REGULATORS

Compact, Stainless Steel Models, Cost-Effective

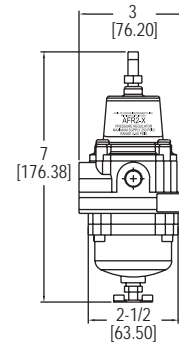
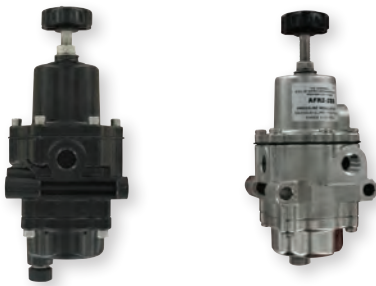

**Series AFR2 Instrument Air Filter Regulators** provide clean air pressure to pneumatic controllers, valve positioners, air cylinders and other equipment. Self-relieving regulator is equipped with a 5 micron filter housed in a dripwell with gage port.

### FEATURES/BENEFITS

- Compact size
- Self-relieving regulator
- 5 micron filter

### APPLICATIONS

- Air filter regulator provides clean air pressure to pneumatic controllers, valve positioners, air cylinders and other equipment

### MODEL CHART

Model	Range	Body
AFR2-1	0 to 60 psi (0 to 4 bar)	Aluminum
AFR2-1SS	0 to 60 psi (0 to 4 bar)	Stainless steel
AFR2-2SS	0 to 121 psi (0 to 8 bar)	Stainless steel

### SPECIFICATIONS

**Service:** Air only.

**Wetted Materials:** Body: Aluminum or SS; Filter: Polyethylene; Diaphragm and valve seat plug: Nitrile elastomer.

**Max. Supply Pressure:** 250 psi (17.2 bar).

**Temperature Limits:** -4 to 158°F (-20 to 70°C).

**Minimum Filtering Size:** 5 micron.

**Process Connection:** 1/4" NPT.

**Weight:** 1.7 lb (0.6 kg), SS models: 3.0 lb (1.4 kg).



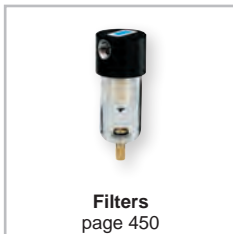

**Filters**  
page 450

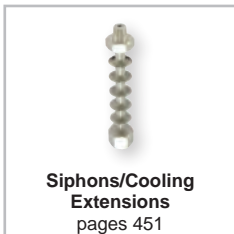

**Siphons/Cooling Extensions**  
pages 451



**Strap Wrench/ Gage Guard**  
pages 452



**Pressure Snubbers**  
pages 453



**Static Pressure Sensors**  
pages 454-455



**Gage Tubing**  
page 455



**Miscellaneous Accessories**  
pages 456-457

## FEATURED PRODUCTS

### STAINLESS STEEL STATIC PRESSURE TIPS

page 454



- Corrosive resistant pressure tips for use in both ducts and rooms provides long service-life
- Kitted to included gasket and screws, eliminates searching for parts and simplifying installation

### STATIC PRESSURE PICK-UP

page 455



- Wall plate design provides an effective means to pick-up room pressure without exposing sensing elements to damage
- Easy mounting to multitude of wall surfaces permits flexible use and helping to support room designs



MODEL F222 & F451

# LIQUID/PARTICLE FILTERS

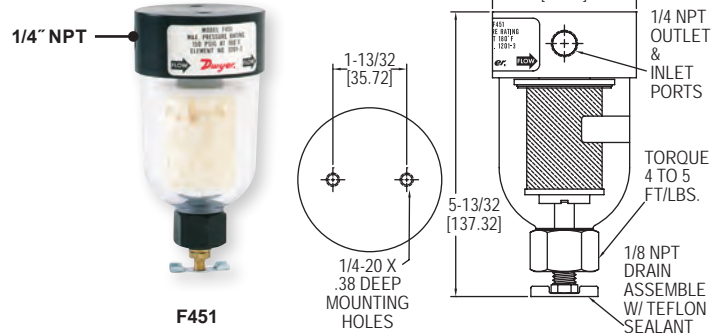
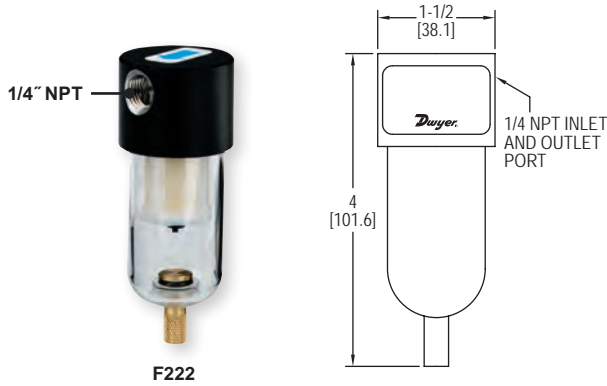

**Model F222 & F451 Liquid/Particle Filters** protect equipment and instrumentation from harmful contaminants such as dirt, water and oil. Liquids are continuously coalesced and released through the manual drain valves. Replaceable filter element removes particles and droplets as small as 0.01 micron with 93% efficiency. Units have 1/4" female NPT inlet and outlet and manual drain valve.

MODEL CHART	
Model	Description
F222	Liquid/particle filter
F451	Liquid/particle filter
1201-3	Replacement filters for F451 (pack of 3)

SPECIFICATIONS	
<b>Filtration Efficiency:</b>	93% (removal of 0.01 micron particles).
<b>Maximum Pressure:</b>	150 psig (10 bar).
<b>Maximum Temperature:</b>	130°F (54°C).
<b>Max. Flow at 100 psig:</b>	22 SCFM (F222); 45 SCFM (F451).
<b>Inlet &amp; Outlet Ports:</b>	1/4" female NPT.
<b>Mounting:</b>	In-line only (F222); 1/4-20 mounting holes (F451).
<b>Materials of Construction:</b>	Anodized aluminum head, polycarbonate bowl, cadmium plated steel tie rod, nylon internals, Buna-N seal.
<b>Weight:</b>	0.5 lb (0.2 kg) (F222); 1.1 lb (0.5 kg) (F451).

MODEL F195

# DISPOSABLE IN-LINE FILTER

Flowmeter Accessories and Options

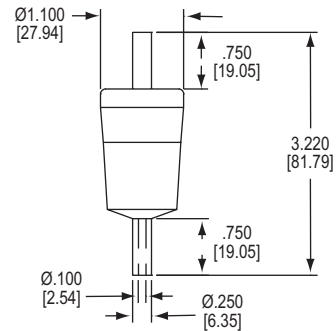

Remove 99.99% of unwanted particles from within your gas flow with the **Model F195 Disposable In-Line Filter**. Encapsulated microfiber filter elements are able to filter particles as small as 0.1 micron. Filters are completely disposable — simply remove the filter from your line and throw it away when it becomes dirty. The transparent nylon housing makes it simple to determine if the filter needs to be changed.

MODEL CHART	
Model	Description
F195	Disposable in-line filter

LINE PRESSURE VS. FLOW									
<b>Line Pressure (psig)</b>	1.5	10	20	30	40	60	80	100	125
<b>Gas Flow (scfm)</b>	0.6	0.9	1.3	1.6	2.0	2.7	3.5	4.2	5.7

**Note:** 1.5 psi pressure drop.

SPECIFICATIONS	
<b>Filtration Efficiency:</b>	99.99% (removal of 0.1 micron particles).
<b>Housing Construction:</b>	Nylon.
<b>Filter Tube Dimensions:</b>	0.59 ID x 1.39 L.
<b>Maximum Temperature:</b>	230°F @ 0 psig (110°C @ 0 bar), 120°F @ 125 psig (49°C @ 9 bar).
<b>Maximum Pressure:</b>	125 psig (8.6 bar).
<b>Maximum Differential Pressure:</b>	60 psi (4 bar) (in-to-out flow direction), 20 psi (1.4 bar) (out-to-in flow direction).
<b>Internal Volume:</b>	11.5 cc (11.5 ml).
<b>Connections:</b>	Barbed for 1/4" ID tubing.

# INSTRUMENTATION SIPHONS

Protect Instrumentation in High Temperature Applications

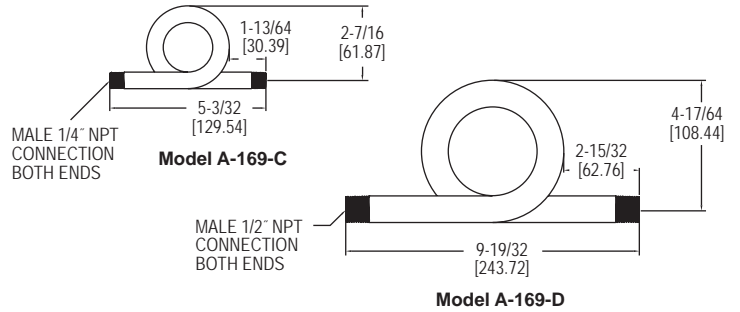

\*Please see our website for additional dimensional drawings.

The **Series A-169/A-170 Instrumentation Siphons** protect pressure instruments in high temperature applications. Water held in the 180° coil prevents steam from contacting the instrument. Constructed in either carbon steel or 316 stainless steel, the instrumentation siphons can withstand high temperature, pressure, or resistance to corrosion. They are ideal for use with pressure gages and instrumentation where the process media temperature exceeds the rating of the instrument. The male NPT connection allows for easy installation and secure attachment.

**FEATURES/BENEFITS**

- Carbon steel construction
- MNPT connection allowing for easy installation
- Stainless steel construction

**APPLICATIONS**

- HVAC
- Industrial process

**SPECIFICATIONS**

**Service:** Compatible liquids and gases.  
**Wetted Materials:** Carbon steel or 316 SS (depending on model).  
**Pressure Limits:** See chart.  
**Temperature Limits:** See chart.  
**Process Connections:** See chart.  
**Weight:** 1/4" NPT models: 8 oz (226.8g); 1/2" NPT models: 25.6 oz (725.75 g).

**MODEL CHART**

Model	Process Connections	Material	Pressure Limit
A-169-C	1/4" NPT male	Carbon steel SCH 80	500 psi @ 680°F
A-169-D	1/2" NPT male	Carbon steel SCH 80	500 psi @ 680°F
A-170*	1/4" NPT male	316 SS SCH 80	2307 psi @ 200°F
A-170-A	1/4" NPT male	316 SS SCH 40	500 psi @ 680°F
A-170-B	1/2" NPT male	316 SS SCH 40	500 psi @ 680°F

\*Model A-170 is not RoHS certified.

SERIES A-240/A-250

# PERFORATED OR SPIRAL COOLING TOWERS

Protect Instrumentation in High Temperature Applications



A-240

A-250

**CONNECTION CHART**

1/4" male/female NPT
3/8" male/female NPT
1/2" male/female NPT
1/4" male/female BSPP
3/8" male/female BSPP
1/2" male/female BSPP

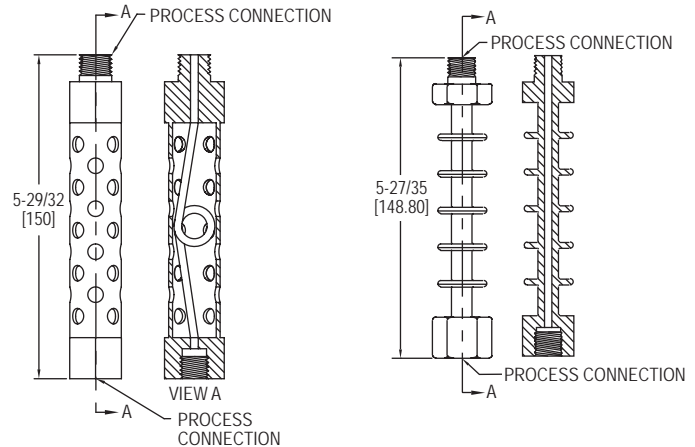

The **Series A-240/A-250 Perforated or Spiral Cooling Towers** protect pressure instruments during high temperature applications. Both the spiral and perforated styles are made with 316L SS, and are available with various process connections in NPT or BSPP style. Both Cooling Towers are ideal for use with pressure gages, switches, and transmitters where the process media temperature exceeds the rating of the instrument.

**FEATURES/BENEFITS**

- Stainless steel construction
- NPT or BSPP connections allowing for easy installation

**APPLICATIONS**

- HVAC
- Industrial Process

**SPECIFICATIONS**

**Service:** Compatible liquids and gases.  
**Wetted Parts:** 316L SS.  
**Temperature Limits:** 428°F (220°C).  
**Pressure Limits:** 5800 psi (400 bar).  
**Process Connections:** See chart.  
**Height:** 6" (150 mm).  
**Weight:** 8 oz (227 g).

**MODEL CHART**

Model	Style	Connections	Model	Style	Connections
A-240-A	Perforated	1/4" male/female NPT	A-250-A	Spiral	1/4" male/female NPT
A-240-C	Perforated	1/2" male/female NPT	A-250-C	Spiral	1/2" male/female NPT
			A-250-D	Spiral	1/4" male/female BSPP
			A-250-E	Spiral	3/8" male/female BSPP
			A-250-F	Spiral	1/2" male/female BSPP



MODEL SWUK1

# STRAP WRENCH

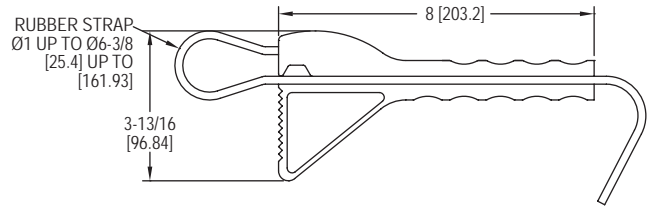

The **Model SWUK1 Strap Wrench** offers the user a versatile tool to grip, undo & tighten a wide variety of awkwardly shaped and sized objects. The SWUK1 also makes the job of fitting Adjustable Signal Flags (ASF) covers to Magnehelic® Differential Pressure Gages much easier by simply following the instruction included with each cover supplied.

MODEL CHART	
Model	Description
SWUK1	Strap wrench

**FEATURES/BENEFITS**

- Reinforced plastic handle provides extra leverage
- Rubber strap reinforced with 38 cords of high tensile polycarbon to give a breaking strength in excess of 2000 lb
- Strap will grip objects from .79" to 6.30" diameter
- Low cost, rugged and simple to use
- Handy multi-purpose tool

**SERIES GG**

# GAGE GUARD

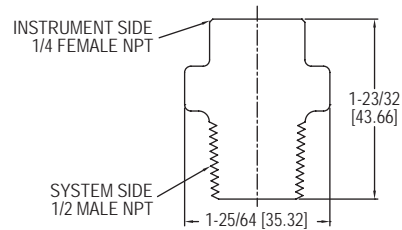

Protecting pressure or vacuum instruments from clogging, corrosion, or damage, the **Series GG Gage Guard** provides a protective barrier between the process fluid and the instrument. The hermetically-sealed uni-body protects from the possibility of leaking. Glass-filled Polypropylene housing is suitable for most inorganic chemicals and temperatures up to 185°F (85°C). A fluid fill station is recommended for proper installation.

SPECIFICATIONS	
<b>Maximum Pressure:</b> Liquids: 160 psi (11 bar) @ 70 to 185°F (21 to 85°C); Gases: 100 psi (6.9 bar) @ 70 to 100°F (21 to 38°C) and 30 psi (2.1 bar) @ 100 to 185°F (38 to 85°C).	
<b>Accuracy:</b> ±4%.	
<b>Maximum Temperature:</b> 185°F (85°C).	
<b>Wetted Parts:</b> Glass-filled polypropylene housing, Buna-N or fluoroelastomer diaphragm.	
<b>Dimensions:</b> 1/4" female NPT instrument side; 1/2" male NPT system side; 1-3/8" (35 mm) diameter.	

MODEL CHART	
Model	Description
GG1	Buna-N diaphragm
GG2	Fluoroelastomer diaphragm



# PRESSURE SNUBBER

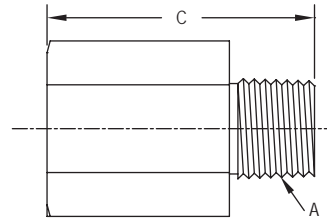
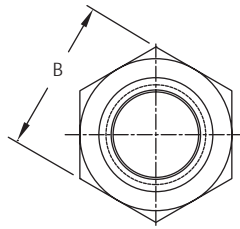

DIMENSIONS			
Model	A	B	C
PS114	1/8" NPT	1/2"	1-7/64"
PS214	1/8" NPT	1/2"	1-7/64"
PS122	1/4" NPT	3/4"	1-1/2"
PS124	1/4" NPT	3/4"	1-1/2"
PS222	1/4" NPT	3/4"	1-1/2"
PS224	1/4" NPT	3/4"	1-1/2"
PS225	1/4" NPT	3/4"	1-1/2"

The **Series PS Pressure Snubber** is designed to protect pressure instrumentation by dampening surges and pulsations and assuring steady average pressure readings. Snubbers are available in a variety of pore sizes for use with gases, water, and oils.

### SPECIFICATIONS

**Maximum Pressure:** Brass: 10,000 psi (689 bar), SS: 15,000 psi (1034 bar).

**Filter Disc Material:** AISI 316 SS.

**Approx. Micron Rating:** Air & gases: 2-5 $\mu$ ; water & oils (30-225 SSU): 10 $\mu$ .

**Dimensions:** 1/4" NPT: 3/4" (19 mm) hex size, 1.5" (38 mm) length.

MODEL CHART		
Model	Service	Construction
PS114	Air and gases	Brass 1/8" NPT
PS214	Air and gases	SS 1/8" NPT
PS122	Water and oils	Brass 1/4" NPT
PS124	Air and gases	Brass 1/4" NPT
PS222	Water and oils	SS 1/4" NPT
PS224	Air and gases	SS 1/4" NPT
PS225	Pulsating gas	SS 1/4" NPT

USA: California Proposition 65

⚠WARNING: Cancer and Reproductive Harm - www.P65Warnings.ca.gov

# ADJUSTABLE PRESSURE SNUBBERS

Protect Instruments from Pressure Spikes or Fluid Hammer



Brass



316 SS

DIMENSIONS				
Connections	A	B	C	H
1/4" M x F	55	42	13	25.0
3/8" M x F	60	44	16	25.0
1/2" M x F	60	40	20	28.0

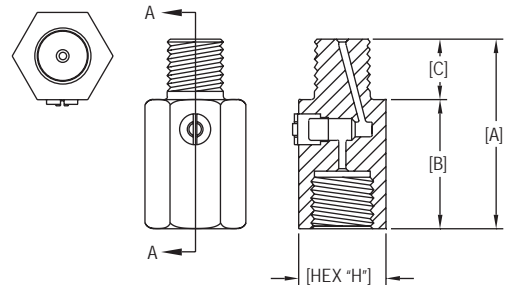

The **Adjustable Pressure Snubbers** protect pressure instruments against fluctuations, surges, spikes and fluid hammer. The fine thread adjustable valve allows you to fine tune harmful harmonic vibration from the fluid systems and isolate the instrument from process when service or replacement is necessary. These Pressure Snubbers are designed to provide fully field adjustable dampening. By using our Adjustable Pressure Snubbers, you will alleviate surges and pulsations to assure steady pressure readings and extend the life of your instrument.

### SPECIFICATIONS

**Service:** Compatible liquids and gases.

**Wetted Parts:** Brass or 316 SS.

**Pressure Limits:** 5690 psi (392 bar).

**Temperature Limits:** -4 to 302°F (-20 to 150°C).

**Process Connections:** See chart.

**Weight:** 8.4 oz (238 g).

MODEL CHART					
Model	Material	Connections	Model	Material	Connections
A-251	Brass	1/4" male/female BSPP	A-257	316 SS	1/4" male/female BSPP
A-252	Brass	3/8" male/female BSPP	A-258	316 SS	3/8" male/female BSPP
A-253	Brass	1/2" male/female BSPP	A-259	316 SS	1/2" male/female BSPP
A-254	Brass	1/4" male/female NPT	A-260	316 SS	1/4" male/female NPT
A-255	Brass	3/8" male/female NPT	A-261	316 SS	3/8" male/female NPT
A-256	Brass	1/2" male/female NPT	A-262	316 SS	1/2" male/female NPT

USA: California Proposition 65

⚠WARNING: Cancer and Reproductive Harm - www.P65Warnings.ca.gov



# STATIC PRESSURE TIPS

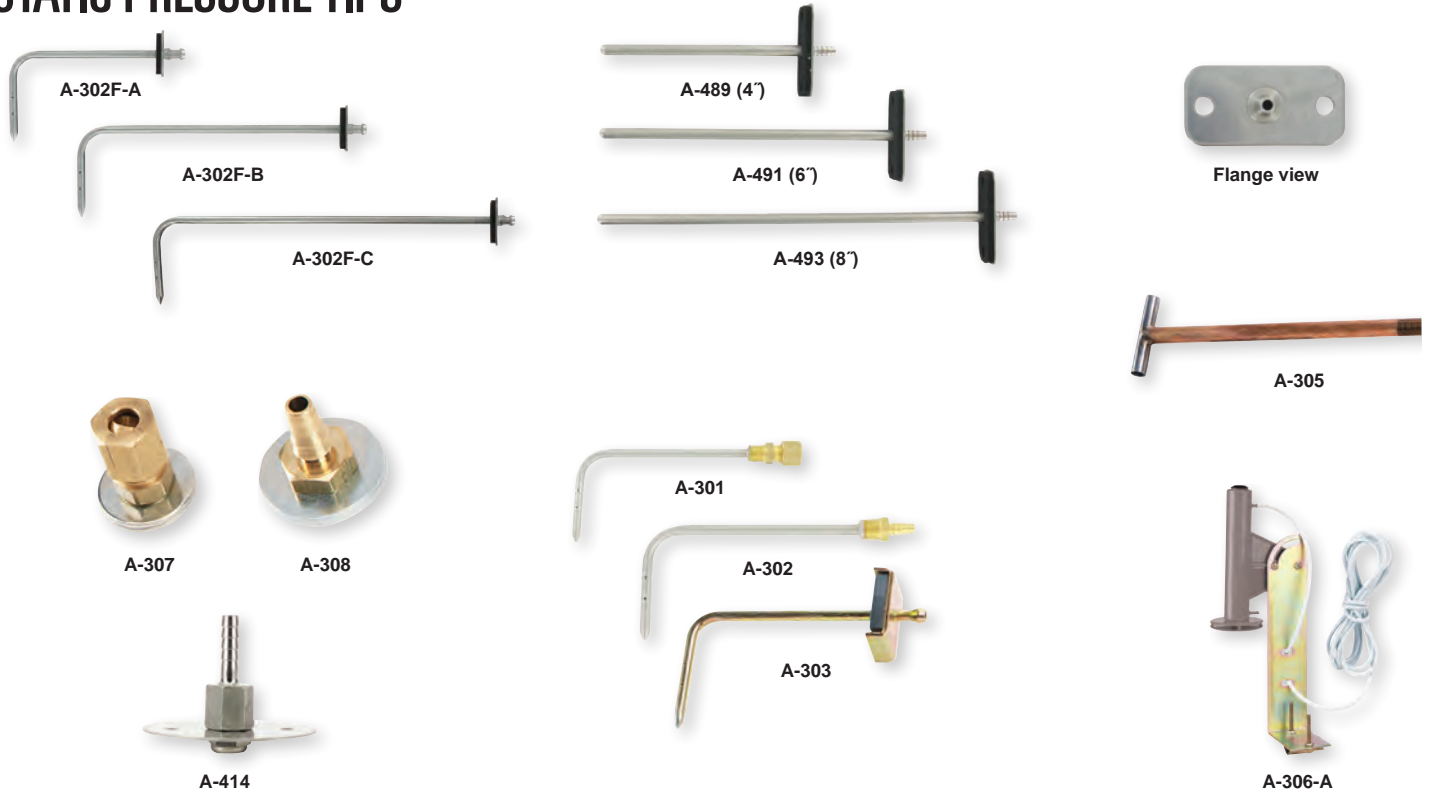

MODEL CHART	
Model	Description
The stainless steel static pressure tips are used to measure static pressures in ducts or rooms. They are to be connected to differential pressure switches and transmitters. Two static sensors are used in applications where differential pressure is required across a filter or coil. These sensors include a mounting flange with integral rubber gasket and two screws for simplifying mounting on a duct.	
A-302F-A	4" hook style SS static pressure tip with mounting flange
A-302F-B	6" hook style SS static pressure tip with mounting flange
A-302F-C	8" hook style SS static pressure tip with mounting flange
A-489	4" straight SS static pressure tip with mounting flange
A-491	6" straight SS static pressure tip with mounting flange
A-493	8" straight SS static pressure tip with mounting flange
Designed for simplified installation, these are easy to install, inexpensive, and provides accurate static pressure sensing in smooth air at velocities up to 1500 FPM.	
A-307	Static pressure fitting, for 1/4" metal tubing connection
A-307-SS	SS static pressure fitting, for 1/4" metal tubing connection
A-308	Static pressure fitting, for 3/16" and 1/8" ID plastic or rubber tubing
A-414	SS clean room pressure sensor
These static pressure tips are ideal for applications such as sensing the static pressure drop across industrial air filters and refrigerant coils. Here the probability of air turbulence requires that the pressure sensing openings be located away from the duct walls to minimize impingement and aspiration, and thus ensure accurate readings. For a permanent installation of this type, the Dwyer No. A-301 or A-302 static pressure tip is used. It senses static pressure through radially-drilled holes near the tip and can be used in air flow velocities up to 12,000 FPM. The angled tips shown have 4" insertion depth. Each has four radially drilled .040" sensing holes. All except Model A-303 mount in 3/8" hole in duct. For portable use, a magnet holds No. A-303 in place.	
A-301	Static pressure tip, for 1/4" metal tubing connection
A-301-A	Static pressure tip, same as A-301 with 6" insertion depth
A-301-B	Static pressure tip, same as A-301 with 8" insertion depth
A-301-C	Static pressure tip, same as A-301 with 12" insertion depth
A-301-SS	SS static pressure tip, for 1/4" metal tubing connection
A-302	Static pressure tip, for 3/16" and 1/8" ID plastic or rubber tubing
A-302-A	Static pressure tip, same as A-302 with 6" insertion depth
A-303	Portable static pressure tip, for 3/16" ID rubber or plastic tubing with 4" insertion
A-305 low resistance static pressure tip is designed for use in dust-laden air and for rapid response applications. It is recommended where a very low actuation pressure is required for a pressure switch or indicating gage — or where response time is critical.	
A-305	Static pressure tip, low resistance application, furnished with two (2) hex jam nuts and two (2) mounting washers for duct mounting and with 1/8" NPT pipe thread for pressure connection
A-305-SS	SS static pressure tip, low resistance application, furnished with two (2) hex jam nuts and two (2) mounting washers for duct mounting and with 1/8" NPT pipe thread for pressure connection
A-306	Outdoor static pressure sensor. Provides average outdoor pressure signal for reference in building pressurization applications. Includes sensor, 50' vinyl tubing, mounting bracket and hardware. Red sensor
A-306-A	Outdoor static pressure sensor. Provides average outdoor pressure signal for reference in building pressurization applications. Includes sensor, 50' vinyl tubing, mounting bracket and hardware. Gray sensor

USA: California Proposition 65  
 ⚠WARNING: Cancer and Reproductive Harm - www.P65Warnings.ca.gov

# STATIC PRESSURE ACCESSORIES

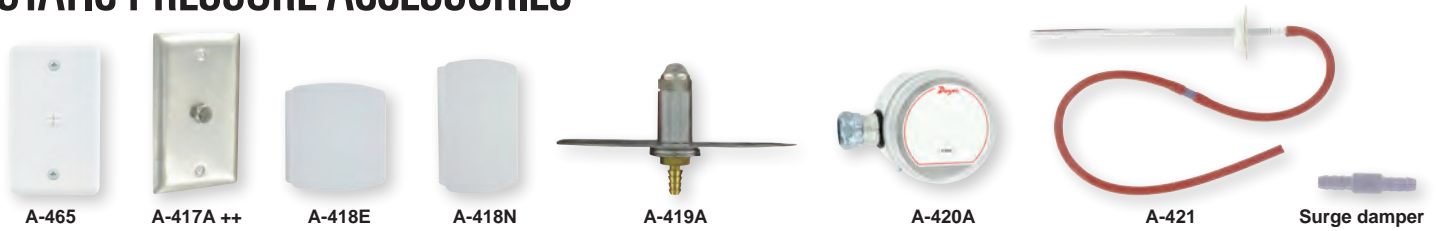

MODEL CHART	
Model	Description
A-465	Static pressure pick-up provides a clean solution for sensing space pressure. The sensor can be mounted on sheetrock walls, single gang electrical boxes, or on ceiling tiles. Molded from ABS plastic, the A-465 provides an integral barb fitting and includes tubing, mounting screws and anchors.
A-417A	Static pressure pickup. For use in clean rooms, 60 micron filter picks up static pressure. Stainless steel wall plate fits 2" x 4" electrical box. Sealed with foam gasket, screws included. Barbed brass fitting holds 1/8" to 3/16" ID tubing.
A-418E	Static pressure pickup. Room mount with plastic enclosure fits 2" x 4" electrical box. Fine mesh screen hides static pressure pickup port. Clean connection to 1/8" to 3/16" ID tubing and pressure sensor. Sealed with foam gasket, screws included.
A-418N	Static pressure pickup. Room mount with plastic enclosure fits 2" x 4" electrical box. Fine mesh screen hides static pressure pickup port. Clean connection to 1/8" to 3/16" ID tubing and pressure sensor. Sealed with foam gasket, screws included.
A-419A	Static pressure pickup ceiling mount. Plate rests on top of standard 3/4" thick ceiling tile while 60 micron filter faces down through 5/8" hole in tile. Filter is barely noticeable in room being monitored. Unit mounts to junction box. Barbed brass fitting holds 1/8" to 3/16" ID tubing.
A-420A	Static pressure pickup for roof or outside mount. Reduces effects of wind gusts to keep pressure readings stable when plate is parallel to ground. Structure withstands harsh environmental elements. Structure is 3-1/4" across and 2-3/8" deep. EMT Conduit fitting is 1/2". Pressure connection is brass barbed fitting for 1/8" and 3/16" ID tubing.
A-421	Static pressure tip measures duct static air pressure. Assembly includes 6" probe, silicon rubber hose, and screws. Built-in surge damper ensures stable readings on pressure sensor. Pressure spike reducer can be added to end of tube to further smooth over pressure fluctuations.

++USA: California Proposition 65  
 ⚠ WARNING: Cancer and Reproductive Harm - www.P65Warnings.ca.gov

# GAGE TUBING ACCESSORIES

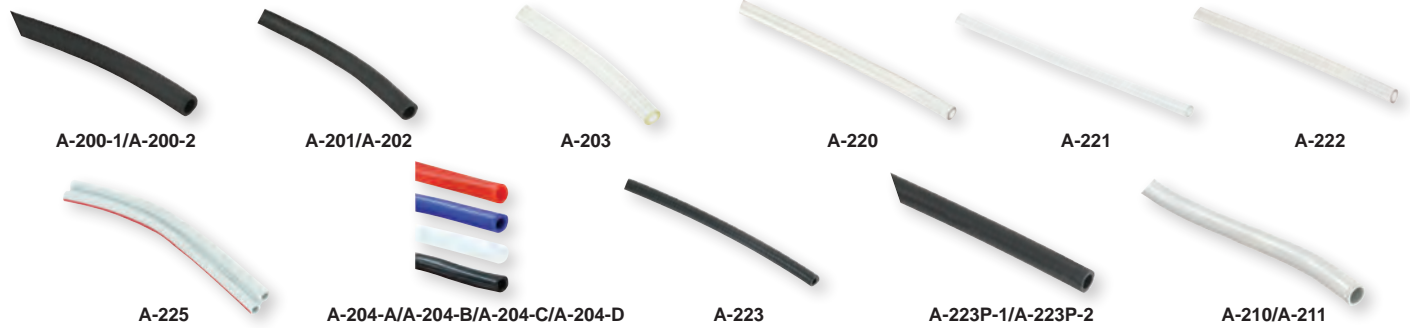

MODEL CHART	
Model	Description
Norprene® tubing is useful in a wide range of temperatures from -75 to 275°F (-60 to 135°C) and will not weaken after long term exposure to heat and ozone.	
A-200-1	3/16" ID x 5/16" OD, 13 psi maximum pressure @ 73°F (90 kPa @ 23°C); 50'
A-200-2	1/4" ID x 3/8" OD, 10 psi maximum pressure @ 73°F (69 kPa @ 23°C); 50'
Rubber latex tubing has less tendency to kink in storage and occupies less space, thus is best for portable work.	
A-201	3/16" ID, 9' length
A-202	3/16" ID, lengths to 50'
Clear PVC tubing is easily inspected and is therefore best for test applications where a possibility of fluid entering the tubing exists.	
A-203	1/8" ID x 1/4" OD, lengths to 100'; 60 psi max. pressure @ 73°F (22°C)
Clear flexible vinyl tubing is easily inspected, and is therefore best for test applications where a possibility of fluid entering the tubing exists.	
A-220	3/16" ID x 5/16" OD, lengths to 500'; 45 psi maximum pressure @ 73°F (310 kPa @ 23°C)
A-221	1/8" ID x 3/16" OD, lengths to 500'; 40 psi maximum pressure @ 165°F (276 kPa @ 74°C)
A-222	.240" ID x .375" OD, lengths to 500'; 35 psi maximum pressure @ 73°F (240 kPa @ 23°C)
Flexible double column plastic tubing is used with Mark II manometers and the Wind Speed Indicator. Light gray with red color code stripe.	
A-225	1/8" ID, lengths to 750'
Flexible colored vinyl tubing is quickly distinguishable in applications where more than one line is required aiding installation.	
A-204-B	3/16" ID x 5/16" OD, lengths to 500'; 45 psi maximum pressure @ 165°F (310 kPa @ 74°C); Opaque blue
A-204-C	3/16" ID x 5/16" OD, lengths to 500'; 45 psi maximum pressure @ 165°F (310 kPa @ 74°C); Opaque white
A-204-D	3/16" ID x 5/16" OD, lengths to 500'; 45 psi maximum pressure @ 165°F (310 kPa @ 74°C); Opaque black
Black polyethylene tubing offers long life, great stability and resistance to corrosion.	
A-223	1/8" ID x 1/4" OD, 10' length; 200 psi maximum @ 140°F (1379 kPa @ 60°C)
Black nylon tubing is recommended for high temperature and pressure applications. -40 to 248°F (-40 to 120°C).	
Black plenum fire retardant polyethylene tubing meets NFPA standard 90A for installation in air-conditioning and ventilating plenum spaces; also used in building automation systems. Lengths to 500', 100 psig maximum pressure @ 75°F (689 kPa @ 24°C).	
A-223P-1	.17" ID x .25" OD
A-223P-2	1/4" ID x 3/8" OD
Aluminum tubing is recommended for permanent installations.	
A-210	1/4" OD, 5' length, 500 psi maximum pressure @ 200°F (3447 kPa @ 93°C)
A-211	1/4" OD, 50' length, 500 psi maximum pressure @ 200°F (3447 kPa @ 93°C)

Norprene® is a registered trademark of Saint-Gobain Abrasives, Inc. Corporation

# ACCESSORIES - FITTINGS & FILTERS



MODEL CHART	
Model	Description
A-323	Elbow compression fitting, brass 1/8" NPT to 1/4" metal tubing
A-324	Compression fitting, brass 1/8" NPT to 1/4" metal tubing
A-326	Compression fitting, brass 1/8" NPT to 3/8" tubing
A-327	5/16" nylon tube union
A-328	1/4" nylon tube union
A-329	1/8" NPT close coupled street ell, brass
A-330	1/8" pipe plug, socket hex, plated steel
A-331	1/8" NPT filter vent plug, nylon and sintered metal
A-332	Bushing, brass, 1/8" to 1/4" NPT
A-333	Bushing, brass, 1/8" to 1/2" NPT
A-334	Close nipple, brass, 1/8" NPT
A-336	90° street L, brass, 1/8" NPT
A-337	Coupling, brass, 1/8" NPT
A-338	Servel adapter, brass 3/8" and 5/16" N.F. threads for gas appliances to 1/8" and 3/16" ID rubber or plastic tubing
A-339	Adapter, brass, 1/8" NPT to 3/16" rubber and 1/8" ID plastic tubing
A-339-SS	316 SS 3/16" hose barb to 1/8" BSPT fitting
A-340	Adapter, nylon, 1/8" NPT to 3/16" ID rubber or 1/4" plastic tubing
A-342	"T" assembly, plastic, for 3/16" ID rubber or 1/4" plastic tubing
A-343	"T" assembly, plastic, for 3/16" plastic tubing
A-343-1	"T" assembly, plastic, for 1/8" ID plastic tubing
A-344	Terminal tube, brass 1/4" diameter tube, 8" L (not shown)
A-345	Flange, aluminum with gasket and sheet metal screws, 1/8" NPT
A-346	"T" compression fitting, brass, 1/4" metal tubing
A-349	Reducer, brass, 1/4" female NPT to 1/8" male NPT
A-385	1/2" plastic hole plugs 20/bag
A-386	5/16" metal hole plugs 20/bag
A-391	Line filter for Capsuhelic® gage, 1/4" female NPT X 1/4" male NPT
A-392	Line filter for Magnehelic® gage, 1/8" female NPT x 1/8" male NPT
A-398	Probe extension adapter for series 640 air velocity transmitter, brass, 1/2" female NPT x 5/16" compression

++USA: California Proposition 65

⚠ WARNING: Cancer and Reproductive Harm - www.P65Warnings.ca.gov

# ACCESSORIES - VALVES & CONNECTORS

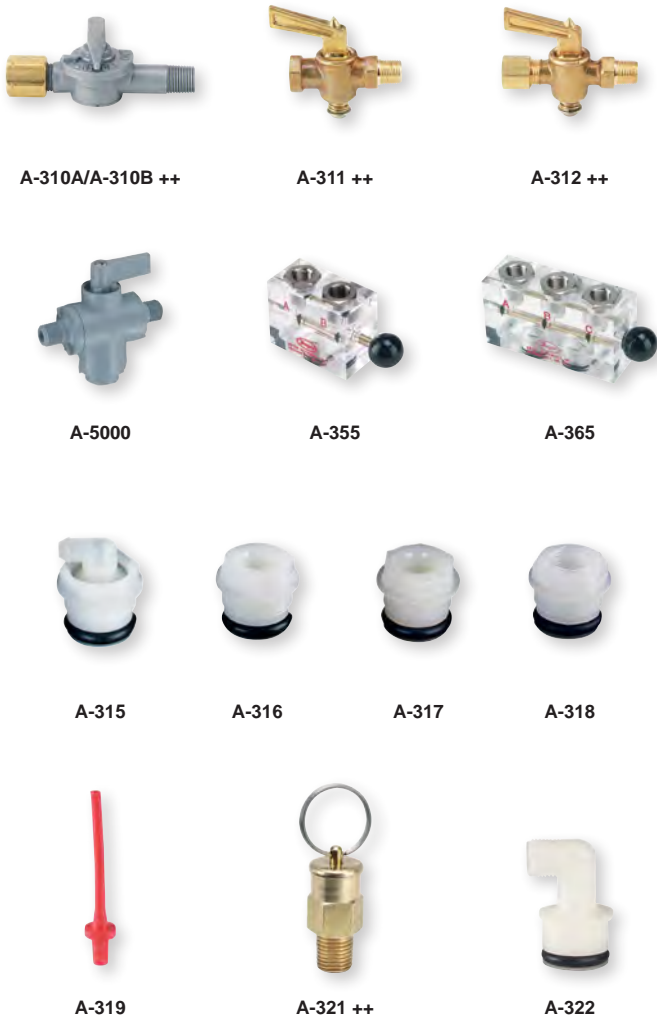

MODEL CHART	
<b>Instrument valves for permanent installation. They mount in part A-316, A-317, type C manometer connections or Magnehelic® gage and connect to metal tubing or 1/8" pipe.</b>	
Model	Description
A-310A	3-way vent valve, plastic, 1/8" NPT to 1/4" metal tubing. Positions are: (1) Line: Gage connected to pressure source. (2) Off: Both gage and connection to pressure source closed. (3) Vent: Gage vented to atmosphere and connection to pressure source closed. 80 psi rating. Replaces former model A310 (brass)
A-310B	Same as A-310A but with 10 psi rating
A-311	Shut off valve, brass, 1/8" NPT to 1/8" NPT
A-312	Shut off valve, brass, 1/8" NPT to 1/4" metal tubing
A-5001-1	PVC 1/8" hose barb inlet x 1/8" hose barb outlet x 1/8" hose barb outlet (125 psi maximum)
A-5002-2	PVC 1/4" hose barb inlet x 1/4" hose barb outlet x 1/4" hose barb outlet (125 psi maximum)
A-5003-3	PVC 1/8" female NPT inlet x 1/8" female NPT outlet x 1/8" female NPT outlet (125 psi maximum)
A-5003-5	PVC 1/8" male NPT inlet x 1/8" female NPT outlet x 1/8" female NPT outlet (125 psi maximum)
A-5004-4	PVC 1/4" female NPT inlet x 1/4" female NPT outlet x 1/4" female NPT outlet (125 psi maximum)
A-5004-6	PVC 1/4" male NPT inlet x 1/4" female NPT outlet x 1/4" female NPT outlet (125 psi maximum)
A-5005-3	PVC 1/8" female NPT inlet x 1/8" male NPT outlet x 1/8" male NPT outlet (125 psi maximum)
A-5006-4	PVC 1/4" female NPT inlet x 1/4" male NPT outlet x 1/4" male NPT outlet (125 psi maximum)
A-355	Porting valve, acrylic plastic, 1/8" NPT inserts. Used for convenient indication of pressure at two points with a single gage
A-365	Dual porting valve, acrylic plastic, 1/8" NPT fittings. For monitoring three pressures, two at a time, with one gage

MODEL CHART	
<b>Gage Connectors for Manometers. Molded nylon construction, threaded .786 x 27 N.S., with O-ring seal.</b>	
Model	Description
A-315	Gage connector, shut off type, for 3/16" rubber tubing
A-316	Gage connector, bushing, 1/8" pipe thread opening
A-317	Gage connector, 1/8" pipe thread opening, less OD thd., for slip fit in 3/4" dia. opening in 250 series A.F. gages
A-318	Gage connector 1/4" pipe thread opening
A-319	Flexible red P.V.C. connector, 3/16" ID rubber tubing to 1/4" ID plastic tube for 1221, 1222 and 1227 manometers
A-321	Brass safety relief valve protects Magnehelic® or Photohelic® gage against over pressure due to regulator failure etc. Opens at 10 psi. Mounts in tee fitting in sensing line or in unused gage port with addition of A-349 reducer. 1/4" male NPT (Use two for D.P. application)
A-322	Gage connector for 1/4" tubing. Slip fits in 3/4" opening in 250 series A.F. gages (compression nut and ferrule not included)

++USA: California Proposition 65

⚠ WARNING: Cancer and Reproductive Harm - www.P65Warnings.ca.gov



## ACCESSORIES - GAGE FLUIDS



MODEL CHART	
Model	Description
Red gage fluid, .826 sp. gr. The standard fluid for use in inclined manometers, "D" type vertical manometers and all Dwyer gages using red fluid.	
A-101	1 oz unbreakable plastic dispenser bottle
A-102	4 oz plastic bottle with screw cap
A-103	1 pt plastic bottle with screw cap
A-104	1 qt plastic bottle with screw cap
Blue gage fluid, 1.910 sp. gr. For special instruments and Mark II Models 26 and 28.	
A-110	1 oz unbreakable plastic dispenser bottle
A-111	1 pt plastic bottle with screw cap
Violet gage fluid, 1.000 sp. gr. Use in place of water if better meniscus is desired.	
A-120	1 oz unbreakable plastic dispenser bottle
A-121	4 oz plastic bottle with screw cap
A-122	1 pt plastic bottle with screw cap
Fluorescein green color concentrate, water coloring agent. Not to be used full strength. Add 3/4 oz to a quart of distilled water. Contains a wetting agent to improve the meniscus characteristics. Use in vertical manometers only.	
A-126	1 oz unbreakable plastic dispenser bottle
<b>Caution:</b> Use only Dwyer fluids in Dwyer gages.	

## ACCESSORIES - MISCELLANEOUS



MODEL CHART	
Model	Description
A-298	Flat aluminum bracket for flush mounting Capsuhelic® gage, 603A, 605, and 3000MR
A-299	Mounting bracket, flush mount Magnehelic® gage in bracket, bracket is then surface mounted, steel with gray hammertone epoxy finish
A-300	Flat aluminum bracket for flush mounting Magnehelic® gage
A-351	Pinch clamp to seal rubber tubing, as in a leakage test
A-352	Magneclip, slip on magnetic holder for acrylic plastic gages, per pair
A-353	Magnetic mounting, flat style, secures to flowmeter, etc. with 6-32 machine screw and boots insert
A-354	Magnetic mounting, edge style, secures edge of acrylic manometer with 10-32 machine screw and boots insert
A-356	Gage plug with retainer loop, polyethylene plastic, for 1/4" ID tubing, slip loop over tubing OD and insert plug for seal
A-357	Thermometer and terminal tube holder, SS wire
A-360	Aluminum DIN rail, 1 m
A-362	Stand-hang bracket, aluminum, for Minihelic® II gage
A-363	Scale clamp bar for 1221 manometer
A-364	Magnet assembly for 1222 manometers, 2 required (3 required for 1222-36 and M-1000)
A-366	Manometer cleaning brush 1/4" OD x 2-1/8" long, attach to wire for use
A-368	Surface mounting plate, aluminum, for Magnehelic® gage
A-369	Stand-hang bracket, aluminum, for Magnehelic® gage
A-370	Mounting bracket, flush mount Capsuhelic® gage or Series 631B transmitter in bracket, bracket is then surface mounted, steel with gray hammertone epoxy finish
A-371	Surface mounting bracket, use with Photohelic® gage on horizontal or vertical surfaces, also for Capsu-Photohelic® gages on vertical only
A-395	Surface mounting bracket for Series 4000 Capsuhelic® gages, steel with gray hammertone epoxy finish
A-397	Rugged step drill quickly provides true round holes in thin materials, ideal for installation of Dwyer pitot tubes in sheet metal duct, no centerpunch needed to steel, drills 3/16" through 1/2" holes in 1/16" increments
A-464	Flush mount kit for Magnehelic® gages
A-465	Flush mount space pressure sensor
A-497	Surface mounting bracket for Minihelic®II gage, steel with satin black finish

## ACCESSORIES - KITS FOR AIR FILTER SWITCHES



MODEL CHART	
Model	Description
A-602	Air filter kit, accessory package for using switch without a gage includes two pressure tips with integral compression fittings, two 5' lengths of 1/4" aluminum tubing and two 1/8" NPT to 1/4" tubing compression fittings
A-603	"T" kit, accessory package for using pressure switch in conjunction with an air filter kit equipped Magnehelic® or Series 250 AF gages includes two 1/8" NPT to 1/4" tubing compression fittings and two compression tees
A-604	"T" kit, accessory package for using pressure switch in conjunction with Mark II gages, includes two plastic tubing connector tees and two plastic tubing to 1/8" NPT adapters

**Absolute Pressure (psia):** The total force per unit area exerted by a fluid. The sum of atmospheric and gage pressures.

**Accuracy:** The degree to which an observed value matches the actual value of a measurement over a specified range.

**Alternating Current (AC):** Current that reverses polarity at a uniform frequency.

**ANSI:** The American National Standards Institute is a private nonprofit organization that oversees the development of voluntary consensus standards for products, services, processes, systems, and personnel in the United States.

**ASTM:** (Formerly known as The American Society for Testing and Materials) An international standards developing organization that develops and publishes voluntary technical standards for a wide range of materials, products, systems, and services.

**Atmospheric Pressure:** The force exerted per unit area by the weight of the atmosphere.

**British Thermal Unit (BTU):** The amount of heat required to raise the temperature of one pound of water by one degree Fahrenheit. Melting a pound of ice at 32°F requires 143 BTU.

**BSPT:** British Standard Pipe Thread.

**Capacitance:** A measure of the amount of electric charge stored (or separated) for a given electric potential. The most common form of charge storage device is a two-plate capacitor.

**Cavitation:** The process where vapor bubbles in a flowing liquid collapse inside a control valve as the pressure begins to increase.

**Closed Loop:** A control system that provides feedback to a controller on the state of the process variable.

**Cold Junction:** The end of thermocouple that is kept at a constant temperature in order to provide a reference point.

**Contacts:** Elements used to mechanically make or break an electric circuit.

**Critical Pressure:** The ratio of upstream to downstream pressure where the gas velocity out of the valve is sonic and further decreases in downstream pressure no longer increase the flow.

**Cv or Valve Flow Coefficient:** The number of US gallons per minute of water at 60°F that will pass through the valve with a pressure drop of 1 psi.

**Deadband:** The value of measurement between when a switch actuates and deactuates.

**Density:** The mass of a given substance per unit volume.

**Derivative Control:** A method of changing the output of a controller in proportion to the rate of change of the process variable.

**Dewpoint:** The temperature to which air must be cooled for the air to be saturated with water.

**Dielectric:** The insulating material between the conductors of a capacitor.

**Dielectric Constant:** The ratio of the insulating ability of a material to the insulating ability of vacuum.

**DIN:** Deutsches Institut für Normung e.V., The German national organization for standardization and is that country's ISO member body. DIN and mini-DIN connectors, as well as DIN rails are several examples of older DIN standards that are today used around the world.

**Direct Current (DC):** A current with a constant polarity.

**Double Pole Double Throw (DPDT) Switch:** Two separate switches that operate simultaneously, each with a normally open and a normally closed contact and a common connection.

**Drift:** A gradual change in an element over time when the process conditions are constant.

**Dry Bulb Temperature:** The ambient air temperature measured by a thermometer that is freely exposed to the air but shielded from other heating or cooling effects.

**Emissivity:** The ratio of energy radiated by the material to energy radiated by a black body at the same temperature. It is a measure of a material's ability to absorb and radiate energy.

**Form-C Contact:** A contact that has both normally open and normally closed contacts.

**Fuzzy Logic:** A system that uses mathematical or computational reasoning based on fuzzy sets derived from analog inputs.

**Gage Pressure (psig):** The measure of force per area exerted by a fluid using atmospheric pressure as the zero reference.

**Gain:** The ratio of change in output to the change in input of a process.

**Hot Junction:** The joined end of the thermocouple that is exposed to the process where the temperature measurement is desired.

**Humidity:** The amount of water vapor in a given volume of air or gas.

**Hydrostatic Pressure:** The pressure due to the head of a liquid column.

**Hysteresis:** A property of a device or instrument whereby it gives different output values in relation to its input values, depending on the directional sequence in which the input values have been applied. [IEC 61298-2]

**Impedance:** The opposition in an electric circuit to the flow of an alternating current consisting of inductive reactance, ohmic resistance and capacitive reactance.

**Inaccuracy:** Maximum positive and negative deviation from the specified characteristic curve observed in testing a device under specified conditions and by a specified procedure. [IEC 61298-2]

**Note 1:** Accuracy is defined in IEC 60050-300, definition 311-06-08.

**Note 2:** The term inaccuracy is sometimes referred to as measured accuracy. This term should not be used.

**Inductive Load:** Current passing through wound or coiled wire creates a magnetic field that in turn produces mechanical work.

**Integral Control:** A method of changing the output of a controller by an amount proportional to the error and the duration of that error.

**Laminar Flow:** Smooth fluid flow that has a parabolic flow profile with no mixing between streamlines.

**Linearity:** Ability of a measuring instrument to provide an indication having a linear relationship with a defined quantity other than an influence quantity. [IEC 60050-300]

**Note:** The method of expression of lack of linearity is different for different kinds of instruments and is established in each particular instance.

**Long-Term Span Drift:** The amount of change of a measured reading with 90% of full scale range pressure applied and constant ambient conditions over a given period of time which is typically quoted as an annual figure. [IEC 61298-2]

**Long-Term Zero Drift:** The amount of change of a measured reading with zero pressure applied and constant ambient conditions over a given period of time which is typically quoted as an annual figure.

**Low Pressure Steam:** As defined by ASME, steam under 15 psi pressure.

**Manual Reset:** A control that must have human input before it will return to its normal state from an alarm state.

**Maximum Surge Pressure:** Safe pressure for the switch housing but which may damage the mechanism by continuous or repetitive application.

**NEMA:** The National Electrical Manufacturers Association, a trade association in the US of electrical equipment manufacturers that develops many industry technical standards, such as the standard for electrical equipment enclosures.

**NIST:** The National Institute of Standards and Technology, is a non-regulatory agency of the United States Department of Commerce's Technology Administration. The institute provides standard references and calibration services.

**Non-Linearity:** Deviation from linearity. [IEC 61298-2]

**Note 1:** Linearity is defined in IEC 60050(300), definition 311-06-05.

**Note 2:** Non-linearity does not include hysteresis.

**Non-Repeatability:** Deviation from repeatability. [IEC 61298-2]

**Note 3:** Repeatability is defined in IEC 60050(300), definition 311-06-06.

**Normally Closed Switch:** A switch in which the contacts are normally closed. Actuation opens the contact.

**Normally Open Switch:** A switch in which the contacts are normally open. Actuation closes the contacts.

**NPT:** National Pipe Thread.

**NSF:** A not-for-profit, non-governmental organization that develops standards and provides product certification and education in the field of public health and safety.

**Null Switch:** A floating contact switch with a zone of no contact. Often used to operate reversible motors.

**pH:** An indication of the acidity or alkalinity of a solution in units ranging from 0 (most acidic), to 7 (neutral), to 14 (most alkaline).

**Predictive Balancing:** An air balance process that involves predicting the ideal flow set points for each terminal under adjustment (TUA) so that every terminal is at target flow throughout the process.

**Pressure Drop:** The difference in upstream and downstream pressure of the fluid flowing through a valve.

**Proportional Balancing:** An air balance process in which terminals under adjustment (TUA) are set in proportion to the key terminal in order for the entire system to be within tolerance of the design.

**Proportional Control:** A method of changing the output of a controller by an amount proportional to the error.

**Proportional-Integral Control (PI):** Proportional and integral control combined.

**Proportional-Integral-Derivative Control (PID):** Proportional, integral, and derivative control combined.

**Range:** The span of rates within which the sensing element of a given switch can be set to actuate an electric switch.

**Rated Pressure:** The maximum pressure that the actuating components of the switch in contact with the media can withstand continuously and/or repeatedly without risk of permanent damage.

**Relative Humidity:** The ratio of the quantity of water vapor in the air to the quantity of water vapor required for saturation at the same temperature.

**Repeatability:** The closeness of agreement between the results of successive measurements of the same measured, carried out under the same conditions of measurement, i.e.: by the same measurement procedure; by the same observer; with the same measuring instruments, used under the same conditions; at relatively short intervals of time. [IEC 60050-300]

**Repetitive Accuracy:** The ability of a switch to operate repetitively at its set point under consistent conditions.

**Response Time:** The time it takes an element to respond to a change in the value of the measured variable or to produce a change in the output signal.

**Rotameter:** A variable area flowmeter consisting of tapered tube and a float.

**RS-232:** (Recommended Standard 232) is a standard for serial binary data signals connecting between a DTE (Data Terminal Equipment) and a DCE (Data Circuit-terminating Equipment).

**RS-485:** (Now known as EIA-485) is an OSI model physical layer electrical specification of a two-wire, half-duplex, multipoint serial connection.

**Saturation Point:** The point at which condensation is formed.

**Serial Transmission:** Sending one bit at a time on a single transmission line.

**Set or Actuation Point:** The exact rate which will cause the electric switch to actuate.

**Single-Pole Single Throw (SPST) Switch:** A switch that only has one of either a normally open or a normally closed contact.

**Single-Pole Double-Throw (SPDT) Switch:** A switch combining both normally open and normally closed switch contacts.

**Solid State:** Any element that controls current without moving parts, vacuum gaps or heated filaments.

**Span:** The difference between the highest and lowest numbers in a range.

**Span Temperature Coefficient:** The maximum amount the span reading could change at any point within the compensated temperature range. This error is typically expressed as a percentage of full scale output of reading. It can also be expressed as percentage of full scale per °C, °F or K e.g.  $\pm 0.02\%FS/^\circ C$ .

**Specific Gravity:** The ratio of the density of a fluid to the density of a reference fluid.

**Static Pressure:** The pressure exerted by a fluid at rest. The outward push of a fluid against the walls of a container.

**Temperature Compensation:** The correction for the influence of temperature on a measurement.

**3-A:** 3-A Sanitary Standards Inc., A non-profit association representing equipment manufacturers, processors, regulatory sanitarians, and other public health professionals that creates standards and accepted practices for dairy and food processing equipment and systems.

**Total Pressure:** The sum of velocity and static pressure.

**Transducer:** Any device that generates an electrical signal from physical measurements.

**Transmitter:** A device that translates the low-level output of a sensor or transducer to a higher level signal suitable for transmission to a site where it can be further processed.

**Turbulent Flow:** Fluid flow in which the flow profile is a flattened parabola, the streamlines are not present, and the fluid is freely mixing.

**Turndown Ratio:** The ratio of the maximum to minimum measurable value that can still produce full-scale output.

**Velocity Pressure (Dynamic Pressure):** The pressure exerted by the velocity of a fluid. Can be measured by the difference between total and static pressure.

**Viscosity:** The resistance of a fluid to flow when subjected to shear stress.

**Wet Bulb Temperature:** The lowest temperature that can be obtained through the cooling effect of water evaporating into the atmosphere.

**Zero Temperature Coefficient:** The maximum amount the output reading at zero pressure might deviate over the compensated temperature range. This error is typically expressed as a percentage of full scale output of reading. It can also be expressed as percentage of full scale per °C, °F or K e.g.  $\pm 0.02\%FS/^\circ C$ .

AREA OF CIRCLES IN FT <sup>2</sup>			
Diam. in	Area	Diam. in	Area
Inches	Square Feet	Inches	Square Feet
1	.0054	30	4.909
1-1/2	.0123	31	5.241
2	.0218	32	5.585
2-1/2	.0341	33	5.940
3	.0491	34	6.305
3-1/2	.0668	35	6.611
4	.0873	36	7.069
4-1/2	.1105	37	7.467
5	.1364	38	7.876
5-1/2	.1650	39	8.296
6	.1964	40	8.727
6-1/2	.2305	41	9.168
7	.2673	42	9.621
7-1/2	.3068	43	10.08
8	.3491	44	10.56
8-1/2	.3940	45	11.04
9	.4418	46	11.54
9-1/2	.4923	47	12.05
10	.5454	48	12.57
11	.6600	49	13.10
12	.7854	50	13.64
13	.9218	51	14.19
14	1.069	52	14.75
15	1.227	53	15.32
16	1.396	54	15.90
17	1.576	56	17.10
18	1.767	58	18.35
19	1.969	60	19.63
20	2.182	62	20.97
21	2.405	64	22.34
22	2.640	66	23.76
23	2.885	68	25.22
24	3.142	70	26.73
25	3.409	72	28.27
26	3.687	74	29.87
27	3.976	76	31.50
28	4.276	78	33.18
29	4.587	80	34.91

ALTITUDE PRESSURE TABLE		
Mercury at 0°C (32°F)		
Altitude in feet	Inches of Mercury	In Millimeters of Mercury
-1,000	31.02	787.9
0	29.921	760.0
1,000	28.86	732.9
2,000	27.82	706.6
3,000	26.81	681.1
4,000	25.84	656.3
5,000	24.89	632.3
6,000	23.98	609.0
7,000	23.09	586.4
8,000	22.22	564.4
9,000	21.38	543.2
10,000	20.58	522.6
15,000	16.88	428.8
20,000	13.75	349.1
25,000	11.10	281.9
30,000	8.88	225.6
35,000	7.04	178.7
40,000	5.54	140.7
45,000	4.36	110.8
50,000	3.436	87.30

SPECIFIC GRAVITIES OF GASES		
(Based on 68°F and 14.7 lb. abs.)		
Acetylene	C <sub>2</sub> H <sub>2</sub>	.897
Air	.....	1.000
Ammonia	NH <sub>3</sub>	.587
Argon	A	1.378
Butane-N	C <sub>4</sub> H <sub>10</sub>	2.390
Butane-ISO	(CH <sub>3</sub> ) <sub>2</sub> CH CH <sub>3</sub>	1.990
Carbon Dioxide	CO <sub>2</sub>	1.517
Carbon Monoxide	CO	.966
Chlorine	CL <sub>2</sub>	2.452
Ethane	C <sub>2</sub> H <sub>6</sub>	1.035
Helium	He	.138
Hydrogen	H <sub>2</sub>	.070
Methane	CH <sub>4</sub>	.553
Natural Gas	.....	.665 (Approx. Avg.)
Nitric Oxide	NO	1.035
Nitrogen	N <sub>2</sub>	.966
Nitrous Oxide	N <sub>2</sub> O	1.518
Oxygen	O <sub>2</sub>	1.103
Propane	C <sub>3</sub> H <sub>8</sub>	1.550
Sulphur Dioxide	SO <sub>2</sub>	2.209

VOLUME EQUIVALENTS		
1 Cu. Ft.	1 Gal. (U.S.)	1 Liter
1728 Cu. In.	231 Cu. In.	.0353 Cu. Ft.
7.481 Gal. (U.S.)	.1337 Cu. Ft.	.2642 Gal. (U.S.)
28.317 Liters	3.785 Liters	1000 Cu. Cm.
28.317 Cu. Cm.	3785 Cu. Cm.	

FLOW EQUIVALENTS							
1 Cu. Ft./Hr.	1 Cu. Ft./Min.	1 CC/Min.	1 CC/Hr.	1 LPM	1 LPH	1 Gal./Min.	1 Gal./Hr.
.0166 Cu. Ft./Min.	60 Cu. Ft./Hr.	60 CC/Hr.	.0167 CC/Min.	60 LPH	.0166 LPM	60 Gal./Hr.	.0167 Gal./Min.
.4719 LPM	28.316 LPM	.000035 Cu. Ft./Min.	.0000005 Cu. Ft./Min.	.035 Cu. Ft./Min.	.00059 Cu. Ft./Min.	.1337 Cu. Ft./Min.	.002 Cu. Ft./Min.
28.316 LPH	1699 LPH	.0021 Cu. Ft./Hr.	.00003 Cu. Ft./Hr.	2.1189 Cu. Ft./Hr.	.035 Cu. Ft./Hr.	8.021 Cu. Ft./Hr.	.1337 Cu. Ft./Hr.
471.947 CC/Min.	28317 CC/Min.	.001 LPM	.000017 LPM	1000 CC/Min.	16.667 CC/Min.	3.785 LPM	.063 LPM
28317 CC/Hr.	1,699,011 CC/Hr.	.06 LPH	.001 LPH	60,002 CC/Hr.	1000 CC/Hr.	227.118 LPH	3.785 LPH
.1247 Gal./Min.	7.481 Gal./Min.	.00026 Gal./Min.	.000004 Gal./Min.	.264 Gal./Min.	.004 Gal./Min.	3,785.412 CC/Min.	63.069 CC/Min.
7.481 Gal./Hr.	448.831 Gal./Hr.	.0159 Gal./Hr.	.00026 Gal./Hr.	15.851 Gal./Hr.	.264 Gal./Hr.	227,125 CC/Hr.	3785 CC/Hr.



SPECIFIC GRAVITY OF LIQUID	
Liquid	Specific Gravity
Acetone	0.792
Alcohol, ethyl	0.791
Alcohol, methyl	0.810
Ammonia, saturated	0.655
Benzene	0.9
Brine (10% Na Cl)	1.08
Carbolic acid	0.950 to 0.965
Carbon disulfide	1.293
Carbon tetrachloride	1.595
Chloroform	1.489
Ether	0.736
Fuel oil 1	0.82 to 0.95
Fuel oil 2	0.82 to 0.95
Fuel oil 3	0.82 to 0.95
Fuel oil 5A	0.82 to 0.95
Fuel oil 5B	0.82 to 0.95
Fuel oil 6	0.82 to 0.95
Gas oils	0.89
Gasoline a	0.74
Gasoline b	0.72
Gasoline c	0.68
Glycerine	1.260
Heptane-n	0.688
Hexane	0.664
Kerosene	0.820
Mercury	13.600
Methyl acetate	0.93
Methyl iodide	2.28
Milk	1.028 to 1.035
Naptha, petroleum ether	0.665
Naptha, wood	0.848 to 0.810
Oil, castor	0.969
Oil, coconut	0.925
Oil, cotton seed	0.926
Oil, creosote	1.040 to 1.200
Oil, linseed, boiled	0.924
Oil, olive	0.918
Oil, palm	0.924
Oil, peanut	0.92
Oil, sesame seed	0.923
Oil, soy bean	0.924 to .928
Pentane	.623
Propylene glycol	1.038
SAE 30 lube oil	0.9
Sea water	1.025
Sodium chloride, 5%	1.037
Sodium chloride, 25%	1.196
Sodium hydroxide (caustic soda), 20%	1.22
Sodium hydroxide (caustic soda), 30%	1.33
Sodium hydroxide (caustic soda), 40%	1.43
Turpentine (spirits)	0.870
Water	1.000



AGENCY APPROVALS	
	Products with this symbol meet certain requirements for 3-A Sanitary Standards for design and fabrication as governed by 3-A SSI.
	Products with this symbol have had representative samples tested to meet BTL compatibility.
	Products with this symbol conform to certain standards and are eligible to be placed on the market in the European Community.
	This symbol assures you that the product meets certain safety standards and/or performance criteria as set by the Canadian Standards Association.
	Products with this symbol conform to certain ATEX requirements as set by the European Union.
	Products with this mark meet certain requirements as reported by Factory Mutual Research.
	Products with this mark meet certain Canadian requirements as reported by Factory Mutual Research.
	Products with this mark meet certain Canadian and U.S. requirements as reported by Factory Mutual Research.
	Products with this symbol certify to standards for safety of electrical equipment for explosive atmosphere requirements as set by the IECEX Management Committee ExMC.
	The National Institute of Metrology, Standardization and Industrial Quality is a Brazilian federal autarchy, linked to MDIC, the Ministry of Development, Industry and Foreign Commerce.
	Products with this symbol are listed by NSF International. Samples of these products have been evaluated by NSF and meet the safety standards set forth by NSF International.
	Products with this symbol have had representative samples tested to meet UL's safety requirements. These requirements are primarily based on UL's own published Standards for Safety.
	Products with this symbol have been evaluated by UL to Canadian safety requirements, which may be somewhat different from U.S. safety requirements.
	Products with this symbol indicate compliance with both Canadian and U.S. safety requirements.
	Products with this symbol are certified UL recognized components to U.S. requirements. Component parts are part of a larger product or system. These components may have restrictions on their performance or may be incomplete in construction.
	Products with this symbol are certified UL recognized components to Canadian requirements.
	Products with this symbol are certified UL recognized components to both Canadian and U.S. requirements.

HAZARDOUS LOCATIONS LISTINGS	
Class I (-4)	Flammable gases or vapors are or may be present in sufficient quantities to produce explosive or ignitable mixtures.
Division I (-4A)	Gases or vapors are or may be in the atmosphere in normal operations.
Group A (-2)	Containing acetylene.
Group B (-2)	Containing hydrogen, ethylene oxide & propylene oxide or gases or vapors of equivalent hazard.
Group C (-2)	Containing ethyl-ether vapor, ethylene or cyclopropane.
Group D (-2)	Containing gasoline, hexane, naphtha, benzene, butane, propane, alcohol, acetone, lacquer solvent or natural gas.
Division II (-4B)	Gases or vapors are not normally present. They may be present due to leakage, accidents or maintenance. It is possible for one atmosphere to contain the same items as listed for Groups of Division I of this class.
Class II (-5)	Combustible dust may be present in sufficient quantities to produce an explosive atmosphere.
Division I (-5A)	Dust in suspension. Dust is or may be present in the atmosphere due to normal operating conditions.
Class E (-2)	Containing metal dust, including aluminum, magnesiums and their commercial alloys, and other metals of similar hazardous characteristics.
Group F (-2)	Containing carbon black, coal or coke dust.
Group G (-2)	Containing flour, starch or grain dust.
Division II (-5D)	Dust not normally in suspension. Possibly containing the same items as listed for Groups of Division I of this class.
Class III (-6)	Ignitable fibers are present, but not necessarily present in air in quantities sufficient to produce ignitable mixtures.
Division I (-6A)	Easily ignitable fibers or materials producing combustible flyings are handled, manufactured or used.
Division II (-6B)	Easily ignitable fibers are stored or handled.



NEMA STANDARDS FOR INDUSTRIAL ENCLOSURES	
Type 1	General purpose - indoor.
Type 2	Drip-proof - indoor. Protects against limited amounts of falling liquids and dirt.
Type 3	Dust-tight, raintight and sleet resistant - outdoor. Protects against windblown dust, rain sleet and external ice formation.
Type 3R	Same as Type 3, except not dust-tight.
Type 3S	Same as Type 3, but provides for operation of external mechanism when ice-laden.
Type 4	Watertight and dust-tight - indoor and outdoor. Protects against windblown dust and rain, splashing water and hose-directed water.
Type 4X	Same as Type 4 except also corrosion resistant.
Type 5	Dust-tight - indoor. Protects against dust and falling dirt.
Type 6	Submersible, watertight and dust-tight - indoor and outdoor. Protects against water entry during occasional temporary submersion to a limited depth.
Type 6P	Same as Type 6 except for prolonged submersion.
Type 7	Class I indoor hazardous locations. Explosion-proof, may be A, B, C or D.
Type 8	Class I indoor or outdoor hazardous locations - oil immersed equipment, may be A, B, C or D.
Type 9	Class II indoor hazardous locations. Explosion-proof, may be E, F or G.
Type 10	Mining Enforcement Safety Administration. Explosion-proof in methane or natural gas.
Type 11	Corrosion resistant and drip-proof - oil-immersed - indoor.
Type 12	Dust-tight and drip-tight - indoor, non-corrosive dripping liquids.
Type 12K	Same as Type 12 except enclosures have knockouts.
Type 13	Oil-tight and dust-tight - indoors, non-corrosive spray of water, oil and coolant.

IP CODES FOR INDUSTRIAL ENCLOSURES			
Example	IP	0 0	IP00 - No special protection from solids or liquids
Ingress Protection	IP		IEC 60529 degrees of protection provided by enclosures (IP code)
Protection from Solids		0	No protection
		1	Protection against solid objects larger than 50 mm in diameter
		2	Protection against solid objects larger than 12 mm in diameter
		3	Protection against solid objects larger than 2.5 mm in diameter
		4	Protection against solid objects larger than 1 mm in diameter
		5	Dust protected
		6	Dust tight
Protection from Liquids		0	No protection
		1	Protection against dripping water
		2	Protection against dripping water when tilted 15 degrees
		3	Protection against spraying water
		4	Protection against splashing water
		5	Protection against water jets
		6	Protection against powerful water jets
		6K	Protection against powerful water jets with increased pressure
		7	Protection against temporary immersion up to 1m depth
	8	Protection against immersion of 1m or more depth	
	9K	Protection against powerful water jets with high temperature	
*Protection stated above is in reference to protection of the internal equipment housed inside of the enclosure The IP code may be followed by one or two characters for special conditions during testing.			

**REGISTERED TRADEMARKS OF DWYER INSTRUMENTS, INC.**

Capsuhelic®	Lin-E-Aire®	Plast-A-Vane®
Capsu-Photohelic®	Magnehelic®	Preciso® Quick-View®
DigiHelic®	MagneSense® Mercoid®	Rate-Master®
DigiMag®	Mercoid Control®	Safe-T-Ohm®
Duotect®	Microtector®	Slack Tube®
Durablock®	Minihelic® Mini-Master®	SMART Air Hood®
Dwyer Group®	Mini-Photohelic®	Spirahelic®
Dwyer®	Mobile Meter®	The Low Pressure People®
Flex-Tube®	One-Touch®	Visi-Float®
Flotect®	Optitrol®	
Iso Verter®	Photohelic®	

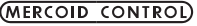
**COMMON LAW MARKS OF DWYER INSTRUMENTS, INC.**



AQStick™	Mother Node™	Tell Tale™
Even-Action™	PredictAir™	Tell Tale Jr.™
Hi-Flow™	Pre-Trac™	Thermoguide™
Loop Alarms™	Proximity™	Ultra-Mag™
Lovelink™	S-D™	Ultra-View™
Mini-Node™	Slide Guide™	Vaneometer™
Minitorator™	SLiquid™	

**COMMONLY USED MARKS & GRAPHICS**







**MARKS REGISTERED TO COMPANIES OTHER THAN DWYER INSTRUMENTS, INC.**



Underwriters Laboratories, Inc.



Underwriters Laboratories, Inc.



Underwriters Laboratories, Inc.



MasterCard International Inc.



Visa International Services Association



Canadian Standards Association



FM Global Technology



BACnet International, Inc.

Alumel®	Conceptech, Inc.	IOS®	Cisco Systems, Inc.	Velcro®	Velcro Industries B.V.
Android®	Google, Inc.	Lexan®	SABIC Innovative Plastic IP B.V.	Windows®	Microsoft Corporation
Chromel®	Conceptech, Inc.	Loctite®	Henkel Corporation	Windows NT®	Microsoft Corporation
Darina®	Shell Trademark Management B.V.	Modbus®	Schneider Automation, Inc.	Windows Vista®	Microsoft Corporation
Duracell®	The Gillette Company	Norprene®	Saint-Gobain Abrasives, Inc. Corporation	Excel®	Microsoft Corporation
Eveready®	Eveready Battery Company, Inc.	Nylatch®	Southco, Inc.	PowerPoint®	Microsoft Corporation
Fluon®	AGC Chemicals Americas, Inc.	Open I/O®	Easton Controls, Inc.	Air Flow™	TSI, Inc.
Fluorolube®	Gabriel Performance Products LLC	Open Signal®	Easton Controls, Inc.	No More Leaks™	Permatex
Freon®	E.I. DuPont De Nemours and Company	Sensorpak®	Easton Controls, Inc.	Precision Flow™	Sierra Instruments, Inc.
HART®	Hart Communication Foundation	Sensorpulse®	Easton Controls, Inc.	ProHood™	TSI, Inc.
Hirschmann®	Hirschmann Electronics GMBH	Swagelock®	Swagelock Company	Smart Interface™	Ientek Co., Ltd.
HyperTerminal®	Hilgraeve, Inc.	Trendreader®	ACR Systems, Inc.		
Igilde®	Igus GMBH	Tygon®	Saint-Gobain Abrasives, Inc. Corporation		
Inconel®	Huntington Alloys Corporation	VCR®	Swagelok Company		

**INFORMATION ABOUT MERCURY-ADDED PRODUCTS**

Dwyer Instruments, Inc. continues its development of non-mercury replacement alternatives for those products currently offered containing mercury. We will continue to work with all customers to supply mercury added products as needed for replacement of products currently in use and to guide customers towards non-mercury added products for new applications.

Dwyer Instruments, Inc. will comply with all local, state, federal, and international laws regarding the sale of mercury added products. These laws may affect our ability to sell, distribute, or transport products into restricted states and/or countries. Mercury added product sales may be limited or denied to certain customers depending on the location or intended use of the product.

Dwyer Instruments, Inc. encourages all customers to become familiar and comply with all mercury legislation. Sales of any and all mercury added products will be discontinued to any customer that knowingly or willfully disregards any legislation concerning mercury.

Dwyer Instruments, Inc. requests that all mercury containing products are properly disposed of at the end of their useful life. Many web sites are available to help educate consumers about proper disposal of mercury added products. Please visit [www.newmoa.org](http://www.newmoa.org) for additional information related to mercury usage.

PRODUCT	SECTION	PAGE	PRODUCT	SECTION	PAGE
<b>16B – 1996</b>			<b>5 – 550</b>		
16B	Temperature	120-121	5	Temperature	140
16C	Temperature	119	500	Flow	267
16G	Temperature	122-123	550	Flow	267
16L	Temperature	125	<b>605 – 682</b>		
102	Level	318	605	Pressure	64
123	Level	318	608	Pressure	74
125	Level	318	616D	Pressure	61
160	Test & Data	186	616KD	Pressure	58
160E	Test & Data	187	616KD-LR	Pressure	59
160F	Test & Data	187	616W	Pressure	62
160FW	Test & Data	167	616WL	Pressure	62
160G	Test & Data	189	626	Pressure	102-103
160S	Test & Data	188	628	Pressure	102-103
165	Valves	444	629C	Pressure	76
166T	Test & Data	188	629HLP	Pressure	77
185	Valves	446	636	Pressure	104
195	Valves	446	636D	Pressure	75
1000E	Pressure	93	638R	Pressure	99
1000W	Pressure	93	641	Air Quality	219
1102	Level	318	641B	Air Quality	220
1211	Test & Data	183	641RM	Air Quality	220
1212	Test & Data	183	644	Pressure	99
1213	Test & Data	184	645	Pressure	79
1221, 1222, 1223	Test & Data	182	647	Pressure	78
1227, 1227M	Test & Data	183	655A	Pressure	75
1230, 1235	Pressure	30	657	Air Quality	226
1620	Pressure	53	668B/D	Pressure	60
1630	Pressure	53	670	Air Quality	216
1638	Pressure	53	672	Pressure	100
1640	Pressure	52	673	Pressure	101
1800	Pressure	47	681	Pressure	98
1823	Pressure	47	682	Pressure	100
1831	Pressure	52	<b>765 – 784</b>		
1900	Pressure	49	765	Pressure	83
1910	Pressure	49	781	Process Control	355
1950	Pressure	55	782	Process Control	355
1950G	Pressure	55	783	Process Control	356
1996	Pressure	54	784	Process Control	356
<b>2-5000 – 2900</b>			<b>8 – 862E</b>		
2-5000	Pressure	26-27	8	Temperature	139
200	Pressure	29	8B	Temperature	120-121
250-AF	Pressure	29	8C	Temperature	119
265	Valves	445	8G	Temperature	122-123
285	Valves	446	862E	Temperature	132
295	Valves	446	<b>9</b>		
2000	Pressure	20-23	9	Process Control	355
2000VA	Valves	420-421	9	Temperature	141
2700	Valves	442	<b>4 – 43000</b>		
2800	Valves	442	4	Temperature	140
2900	Valves	443	4B	Temperature	120-121
<b>3PBV – 3500</b>			4C	Temperature	119
3PBV	Valves	412	4G	Temperature	122-123
32B	Temperature	120-121	40T/40M	Temperature	127
38R	Valves	418-419	400	Test & Data	185
300	Pressure	29	420	Pressure	30
3000MR/3000MRS	Pressure	42	460	Test & Data	185
3000WA	Valves	422	471B	Test & Data	171
3100	Pressure	70-71	472A-1	Test & Data	193
3100D	Pressure	70-71	473B	Test & Data	170
3200G	Pressure	106-107	475	Test & Data	176
3400	Pressure	108-109	475-AV Kits	Test & Data	177
3500	Pressure	72-73	476A	Test & Data	178
<b>4 – 43000</b>			477AV	Test & Data	175
4	Temperature	140	477-AV Kits	Test & Data	177
4B	Temperature	120-121	477B	Test & Data	179
4C	Temperature	119	478A	Test & Data	178
4G	Temperature	122-123	480	Test & Data	190
40T/40M	Temperature	127	485B	Test & Data	169
400	Test & Data	185	490A	Test & Data	180
420	Pressure	30	490W	Test & Data	172
460	Test & Data	185	490A-HKIT	Test & Data	173
471B	Test & Data	171	4000	Pressure	31
472A-1	Test & Data	193	43000	Pressure	41
473B	Test & Data	170			
475	Test & Data	176			
475-AV Kits	Test & Data	177			
476A	Test & Data	178			
477AV	Test & Data	175			
477-AV Kits	Test & Data	177			
477B	Test & Data	179			
478A	Test & Data	178			
480	Test & Data	190			
485B	Test & Data	169			
490A	Test & Data	180			
490W	Test & Data	172			
490A-HKIT	Test & Data	173			
4000	Pressure	31			
43000	Pressure	41			



PRODUCT	SECTION	PAGE
<b>A-169 – AVUL</b>		
A-169	Accessories	451
A-170	Accessories	451
A-240/250	Accessories	451
A-286	Pressure	23
A-299	Pressure	23
A-300	Pressure	23
A-302F	Accessories	454
A-310A	Pressure	21
A-320-A	Pressure	23
A-320-B	Pressure	23
A-350	Test & Data	197
A-368	Pressure	23
A-369	Pressure	23
A-371	Pressure	23
A-396A	Test & Data	197
A-417A	Accessories	455
A-418E	Accessories	455
A-418N	Accessories	455
A-419A	Accessories	455
A-420A	Accessories	455
A-421	Accessories	455
A-432	Pressure	20
A-464	Pressure	23
A-465	Accessories	455, 457
A-489	Accessories	454
A-491	Accessories	454
A-493	Accessories	454
A-605	Pressure	20
A-610	Pressure	23
A-700	Process Control	361
A-900, A-901	Level	338
A-5000	Accessories	456
A-IEF	Flow	293
A1F	Pressure	94
A1PS/A1VS	Pressure	95
A2	Pressure	97
A6	Pressure	96
A3000	Pressure	38-39
AAFS	Air Quality	216
ACT	Valves	416-417
Accessories - Gage Fluids	Accessories	457
Accessories - Fittings & Filters	Accessories	456
Accessories - Kits	Accessories	457
Accessories - Misc.	Accessories	457
Accessories - Valves & Connectors	Accessories	456
Adjustable Pressure Snubber	Accessories	453
ADPS	Pressure	45
AFG	Air Quality	214
AFR	Valves	448
AFR2	Valves	448
AFS	Flow	279
AN2	Process Control	354
ANE-1	Test & Data	189
AP	Pressure	96
AP2	Test & Data	168
APM	Process Control	352
APM	Level	338
APS/AVS	Pressure	95
APT	Process Control	360
APV-C	Level	339
APV-I	Level	339
AQH-20	Test & Data	169
AQT1A	Test & Data	165
ARK	Valves	417
ASG	Test & Data	214
AT11910	Pressure	50
AT1ADPS	Pressure	46
AT21823	Pressure	48
AT22000	Pressure	24
AT23000MR/MRS	Pressure	43
AT2605	Pressure	65
AT2DH3	Pressure	37
AT2MS	Pressure	68
AT3A3000	Pressure	40
A-TC	Temperature	138
AVFS	Air Quality	217
AVUL	Air Quality	218

PRODUCT	SECTION	PAGE
<b>B-190 – BYS</b>		
B-190	Level	320
BAP	Level	339
BBV-0	Valves	433
BBV-1	Valves	433
BBV-2	Valves	434
BCHP	Test & Data	199
BDL	Test & Data	202
BDPA	Pressure	45
BHC	Valves	430
BICV	Valves	430
BPI	Process Control	353
BPS-005	Process Control	362
BPS-015	Process Control	362
BT	Temperature	116
BTLRN	Temperature	116
BTO	Temperature	118
BTT	Temperature	133
BTT-E/N	Temperature	133
BV2M	Valves	401
BYS	Valves	432

<b>Capsu-Photohelic® Gage – CXA</b>		
Capsu-Photohelic® Gage	Pressure	41
Capsuhelic® Gage	Pressure	31
CCS	Process Control	357
CCT40/50	Process Control	359
CCT60/70	Process Control	359
CDT	Air Quality	228
CDTA	Air Quality	229
CDTR	Air Quality	230
CDTV	Air Quality	231
CDWP	Air Quality	227
CFS2	Level	319
CHP	Test & Data	197
CLS1	Level	322
CLS2	Level	321
CLT	Level	333
CMS300	Air Quality	233
CMT200	Air Quality	233
Cooling Tower	Accessories	451
CRF2	Level	332
CSE-3R	Process Control	375
CSE-KN	Process Control	376
CSE-N1	Process Control	376
CSG	Test & Data	196
CTF	Level	323
CXA	Pressure	98

PRODUCT	SECTION	PAGE	PRODUCT	SECTION	PAGE
<b>DA-7035N – DX</b>			<b>F195 – FSW2</b>		
DA-7035N	Temperature	132	F195	Accessories	450
DA/DS	Pressure	90-91	F222, F451	Accessories	450
DAFA	Air Quality	217	F6/F7	Level	313-314
DBLM	Level	324	F7-MLK	Level	312
DBV	Valves	401	F7-MM	Level	316
DBVL	Valves	402	F7-MQ	Level	315
DCGII	Pressure	86	F7-MS	Level	317
DCT500A	Process Control	368	FBLT	Level	331
DCT500ADC	Process Control	368	FC-1000	Process Control	363
DCT600	Process Control	369	FDT	Pressure	101
DCT1000	Process Control	370	Flex-Tube® Manometer	Test & Data	182-183
DCT1000DC	Process Control	371	Flotect® Switch	Flow	270-275
DCV	Valves	428-429	Flotect® Switch	Level	309-312
DevCom2000	Pressure	107	FLST	Air Quality	210-211
DFMT	Flow	284	FS-2	Flow	276
DFMT2	Flow	284	FSW2	Level	319
DFS2	Temperature	131			
DH	Pressure	35	<b>G – GVS</b>		
DH Links	Pressure	33	G	Level	326-327
DH3	Pressure	36	Gage Tubing Accessories	Accessories	455
DHII	Pressure	34	GDL	Test & Data	202
Digihelic Links™	Pressure	33	GDL-T	Test & Data	202
Digihelic® Controller	Pressure	34-36	GFC	Flow	298
DigiMag® Gage	Pressure	25	GFM	Flow	296
DLI2	Test & Data	201	GFM3	Flow	297
DLP	Test & Data	201	GFM4	Flow	297
DM-1000	Pressure	25	GG	Accessories	452
DM-2000	Pressure	63	GSTA	Air Quality	232
DP	Pressure	57	GSTC	Air Quality	232
DPG-000	Pressure	85	GVS	Flow	279
DPG-100	Pressure	85			
DPG-200	Pressure	87	<b>H2 – HTDL-20/30</b>		
DPGA	Pressure	84	H2	Pressure	94
DPGAB	Pressure	84	H3	Pressure	56
DPGW	Pressure	84	HCHP	Test & Data	198
DPGWB	Pressure	84	HF	Flow	259
DPM	Process Control	373	HFO	Flow	280
DPMA	Process Control	350	HFPC	Flow	258
DPML	Process Control	350	HFPS	Flow	258
DPMP	Process Control	350	HFT	Flow	280
DPMW	Process Control	350	HGV	Valves	432
DPMX	Process Control	351	HHT	Air Quality	227
DPT	Pressure	88	Hi-Flow™ Valve	Valves	420-422
DR	Flow	256	HM28	Test & Data	181
DS	Flow	262-263	HM35	Test & Data	181
DSGT	Pressure	87	HNV	Valves	431
DT	Valves	440	HP	Test & Data	197
DTFA	Flow	266	HS	Air Quality	221
DTFO	Flow	266	HTDL-20/30	Test & Data	200
DTFW	Flow	266			
Duotect® Switch	Pressure	94	<b>IEF – IWP</b>		
Durablock® Gage	Pressure	29	IEF	Flow	294
Durablock® Manometer	Pressure	30	IEFB	Flow	292-293
DW-DATAPAD	Test & Data	204	IF	Flow	257
DW-USB	Test & Data	203	IP	Valves	441
DW-USB-LCD	Test & Data	203	IPV	Level	340
DW-WIFI	Test & Data	204	IS626	Pressure	110
DX	Pressure	57	ISDP	Pressure	69
			IT	Temperature	117
			IT-W	Temperature	117
			IWP	Pressure	105
<b>E – EPTA</b>			<b>KFDO</b>		
E	Level	326-327	KFDO	Process Control	366
EBV	Level	340			
EC	Temperature	144			
EDA	Pressure	89			
EDPS	Pressure	45			
EPTA	Valves	441			

PRODUCT	SECTION	PAGE
<b>L4 – LPTK</b>		
L4	Level	309
L6	Level	310
L8	Level	311
L10	Level	312
LC1132	Process Control	351
LCR10	Test & Data	200
LCR20	Test & Data	200
LCT216	Process Control	364
LCT316	Process Control	364
LFMA	Flow	253
LFMB	Flow	253
LFMC	Flow	253
LFMD	Flow	253
LFME	Flow	253
LFMF	Flow	253
LPCP	Test & Data	199
LPG4	Pressure	82
LPG5	Pressure	81
LPI	Process Control	353
LPTK	Test & Data	194
<b>MAFS – MW-1</b>		
MAFS	Air Quality	215
Magnehelic® Gage	Pressure	20-21
Magnehelic® Gage Mounting Accessories	Pressure	23
Magnehelic® Gage Options	Pressure	22
Magnehelic® Transmitter	Pressure	64
Magnesense® Transmitter	Pressure	67
Magnesense® II Transmitter	Pressure	66
Mark 1, 3, 4	Valves	436-438
Mark II	Pressure	28
Mark II	Test & Data	184
Mark II WSI	Test & Data	190
MBLT	Level	329
MCS	Process Control	357
MDA	Pressure	51
MDS	Pressure	51
MFS	Flow	291
MFS2	Flow	291
Mini-Master® Flowmeter	Flow	250-251
Mini-Node™	Process Control	361
Mini-Photohelic® Gage	Pressure	44
Minihelic® Gage	Pressure	26-27
MM	Flow	250-251
MN-1	Process Control	361
Mobile Meter® App	Test & Data	166
MP	Pressure	44
MPC	Level	336
MPC Jr.	Level	337
MPM	Process Control	352
MPM	Level	338
MPR	Valves	447
MS	Pressure	67
MS2	Pressure	66
MSCS	Process Control	358
MTL5541	Process Control	366
MTL7706/7787	Process Control	365
MV	Valves	403
MVR	Level	307
MVS	Pressure	97
MW-1	Test & Data	191
<b>NVII</b>		
NVII	Valves	431
<b>O-4 – OSW-100</b>		
O-4	Temperature	149
OLS	Level	320
One-Touch® Transmitter	Pressure	58
OP	Flow	264-265
OSC-200	Air Quality	234
OSW-100	Air Quality	234

PRODUCT	SECTION	PAGE
<b>P – PUF</b>		
P	Level	326-327
P	Temperature	141
P1	Flow	278
P2	Flow	277
P3	Flow	277
P8	Flow	278
PAFS-1000	Air Quality	214
PBLT2	Level	330
PBLTX	Level	330
PBV	Valves	400
PCHP	Test & Data	198
PE	Flow	264-265
PF2	Pressure	33
PFT	Flow	281
PG	Pressure	54
Photohelic® Gage	Pressure	38-39, 42
PLS	Level	325
PLS2	Level	324
PMS	Process Control	374
PMT2	Process Control	372
PPM	Process Control	352
PPM	Level	338
PRECISOR® Positioner Valves	Valves	444-445
PredictAir™ Application Software	Test & Data	164
PS	Accessories	453
PTGD	Pressure	32
PUB	Flow	290
PUB	Test & Data	193
PUF	Flow	290
PUF	Test & Data	193
<b>Quick-View® Indicator – QV</b>		
Quick-View® Indicator	Valves	435
QV	Valves	435
<b>R – RTD</b>		
R	Temperature	139
Rate-Master® Flowmeter	Flow	246-247, 260
RDCV	Valves	428-429
RH-R	Air Quality	226
RHP	Air Quality	224
RHP-E/N	Air Quality	222
RHPLC	Air Quality	223
RHRS	Air Quality	225
RM	Flow	246-247
RMV	Flow	260
RMV II	Flow	260
RP2	Test & Data	168
RRT3	Temperature	118
RSF	Flow	257
RSM	Pressure	61
RSV	Valves	427
RTD	Temperature	137





	PAGE
<b>2</b>	
<b>Valves</b>	
Manifold	433
<b>3</b>	
<b>Valves</b>	
Manifold	433
<b>5</b>	
<b>Valves</b>	
Manifold	434
<b>A</b>	
<b>Accessories</b>	<b>449-457</b>
Connectors	430,456
Cooling Towers	451
Digital Temperature Switch Configuration Key	131
Enclosures	23,338,376
Filters	450,456
Fittings	430,456
Gage Fluid	457
Gage Guards	452
Hosing	455
Humidity Radiation Shield	225
Mounting Brackets	23,457
Pressure Snubbers	453
Psychrometer	169
Regulators and Lubricators	447-448
Siphons	451
Static Pressure	454-455
Strap Wrenches	452
Temperature	131
Thermowells	117,143,147
<b>Actuated</b>	
Actuators	416-417,420-422
Valves	382-391,398-400,404-412,414-415
<b>Actuators</b>	
Electric	416-417
Pneumatic	416-417,420-422
Repair Kit	417
<b>Air</b>	
Filter Instruments	20-23,26-27,33
<b>Air Control</b>	
Manifolds	433-434
<b>Air Filter Instruments</b>	<b>29</b>
<b>Air Filters/Regulators</b>	<b>448,450,447</b>
<b>Air Flow</b>	
Duct Averaging Sensors	214-215
Duct Stations	210-213
Gages	20-27,31
Meters	246-260,266
Meters with Switches	280
Mobile Application	166,168
Sensors	186-189,210-214,219-220,264-265
Stations	210-213
Switches	216-217,270-276,277-280
Transmitters	218
Duct Mount	218
<b>Air Flow Hood</b>	<b>164</b>
<b>Air Hammer</b>	<b>340</b>
<b>Air Handler</b>	<b>34,58-59,146,149,217,226,308</b>
<b>Air Quality</b>	<b>205-234</b>
Applications	208-209
Gas Sensing Transmitters	227-230,232-233
Humidity Transmitters	210-213,216-217,219-227
Pitot Tubes	186-188
Volatile Organic Compound (VOC) Transmitters	231
Duct Mount	231
Wall Mount	231
<b>Air Temperature</b>	
Sensors	133-137,139-149,169,171
<b>Air Velocity</b>	
Duct Averaging Sensors	214-215
Duct Stations	210-213
Flow Stations	210-213
Flow Switches	270-276
Gages	20-27,31,184-185
Indicators	168,171,177,184-185,190-191,216
Manometer	
Digital	174-176
Fluid	184-185
Meters	164,168,171,176-178,184-185,190-192
Mobile Application	166-167
Monitors	184-185,216
Sensors	186-189,210-214,262-265
Switches	216-217,270-275
Test Kits	171,175-177,184-185,191
Transmitters	218-220
Duct Mount	218
Wind Meters	186-191
<b>Air Velocity Transmitter</b>	<b>218</b>
<b>Alarms</b>	
Loop and Limit	125-127,354
Process Indicator	125,351,354
Visual and Audible	45,354

	PAGE
<b>Ambient Air Temperature Sensors</b>	<b>145,148-149</b>
<b>Analog Signal Generator</b>	<b>196</b>
<b>Analyzers</b>	
Carbon Monoxide/Carbon Dioxide	169,194
Flue Gas	194
<b>Anderson® Midwest</b>	<b>268-269,283</b>
<b>Annunciators</b>	<b>354</b>
<b>Applications</b>	
Air Quality	208-209
Flow	242-244
Level	304-305
Pressure	16-17
Process Control	346-347
Temperature	114-115
Test & Data	156-157
Valves	382
<b>AS-Interface</b>	
Position Indicators/Switches/Transmitters	435-439
<b>Assemblies</b>	
Temperature Sensor	142
<b>ATEX</b>	
Barrier	
Galvanic	366
Zener	365
Flow Switches	270-273
Level Switches	309-310
Photohelic® Switch/Gages	40,43
Position Indicators/Switches/Transmitters	436-438
Pressure Controller	
Differential	37
Pressure Gages	
Differential	24
Pressure Switches	56,92
Differential	46,48,50,55
Pressure Transmitter	106-109
Differential	65,70-73
<b>Automated</b>	
Valves	384-400,404-412,414-417
<b>Averaging</b>	
Flow Grid	214
Flow Sensors	214-215
Pitot Tubes	262-263
Temperature Sensors/Clips	149
<b>B</b>	
<b>Backflow Prevention</b>	
Valves	431
<b>BACnet Communication</b>	<b>292,232</b>
Air Velocity Transmitter	218
Duct Mount	218
BTU Meter	295
Carbon Dioxide Temperature and Relative Humidity	229
Nitrogen Dioxide	232
Pressure Transmitters	66
Room Status Monitor	61
Ultrasonic Energy Meter	295
<b>Ball Valves</b>	
Actuators	416-417
Automated	384-400,404-412
Mini	403
Three-Way	404-411,412
Two-Way	384-399,401-403
<b>Battery Powered Temperature Indicator</b>	<b>353</b>
<b>Bayonet Thermocouples</b>	<b>140</b>
<b>Bimetal Thermometers</b>	<b>116,118</b>
<b>Bin Aerator Pad</b>	<b>339</b>
<b>Bin Level Switches</b>	<b>323-237</b>
<b>Bin Vibrators</b>	<b>339-340</b>
<b>Block Manifolds</b>	<b>431,433-434</b>
<b>Boiler</b>	
Flow Switches	274
Level Switches	130,318
Temperature Switches	130
<b>Bourdon Tube</b>	
Pressure Gages	81-83
Pressure Switches	90-91
Temperature Switches	132
<b>BTU Meter</b>	<b>295</b>
<b>Bulk Head Connectors</b>	<b>430</b>
<b>Butterfly Valves</b>	
Actuators	416-417
Automated	414-415
Manual	413-415
Two-Way	413-415
<b>Button Data Loggers</b>	<b>202</b>

	PAGE
<b>C</b>	
<b>Cable Level Switches</b>	<b>319</b>
<b>Calibration Pumps</b>	<b>197-199</b>
<b>Capacitive</b>	
Level Switches	321-322
Level Transmitters	332
<b>Capsu-Photohelic®</b>	<b>41</b>
<b>Capsuhelic®</b>	<b>31,41</b>
<b>Capture Hood</b>	<b>164</b>
<b>Carbon Dioxide</b>	
BACnet Communication	229
Indicators	169,194
Modbus® Communication	229
Sensors	169,194
Transmitters	227-230
Indicating	227-229
<b>Carbon Monoxide</b>	<b>194,232-233</b>
BACnet Communication	232
Indicators	194
Modbus® Communication	232
Sensors	194
Transmitters	232-233
<b>CFM Gages</b>	<b>20-21,25,34-36</b>
<b>Chamber Level Switches</b>	<b>318</b>
<b>Check Valves</b>	<b>430-431</b>
<b>Chemical Control Manifolds</b>	<b>433-434</b>
<b>Circular Chart Recorder</b>	<b>200</b>
<b>Combustion Test Kits</b>	<b>194</b>
<b>Communication</b>	
HART® Software	107
<b>Compact USB Data Logger</b>	<b>203</b>
<b>Compact USB Data Logger with Display</b>	<b>204</b>
<b>Connectors</b>	
Bulk Head	430
<b>Continuity Controls</b>	<b>367</b>
<b>Continuous Cleaning Timer Controllers</b>	<b>368-371</b>
<b>Control Valves</b>	<b>420-422</b>
Actuators	416-417
<b>Controllers</b>	
Dust Collection	368-371
Electro-Pneumatic	441
Fan Speed	363
Flow	338,352
Grounding	367
Level	336-338,352
Mass Flow	298
Process	119-124
Pump	336-338,352
Refrigeration	124,128
Relative Humidity	221
Temperature	119-131
Valves	441
<b>Cooling Towers</b>	<b>451</b>
<b>Counters</b>	<b>364</b>
<b>Current</b>	
Switches	356-358
Transformers	359
<b>Current to Pressure Transducers</b>	<b>441-443</b>
<b>Current/Voltage Signal Generator</b>	<b>196</b>
<b>D</b>	
<b>Dampers</b>	
Position Indicators/Switches/Transmitters	436-440
<b>Data Acquisition</b>	<b>200-204</b>
<b>Data Loggers</b>	<b>200,204</b>
Button	202
Flow	193,288,290
Graphical Display	202
Pressure	201
Temperature	200-204
USB	202-204
Wireless	204
<b>Detectors</b>	
Leak	308
Occupancy	234
Particulate	372-374
Plugged Shoot	326-327
Position	440
Water	308
<b>Dew Point</b>	
Transmitters	222
<b>DH3 Digihelic®</b>	
Mounting	36
<b>Diaphragm Seals</b>	
Pressure Switches	90-92
<b>Diaphragm Valves</b>	<b>428-429</b>

	PAGE
<b>Differential Pressure</b>	
Alarms	45
Gages	20-21,24-27,31-33
Indicating Transmitters	34-36,61-66,69-75,79-80
Indicators	20-21,24-30,32-33,172-176,178-183
Switches	45-57
Switches/Gages	34-44
Transmitters	58-64,69-79,80-80
Diaphragm Seals	70-73
Indicating	34-36,61-67,69-80
<b>Digihelic Links™</b>	<b>33</b>
<b>Digihelic® Controllers</b>	<b>34-37</b>
Software	33
<b>DigiMag®</b>	<b>25</b>
<b>Digital</b>	
Gages	84-87
Indicating	
Meters	
Panel	338,349-353
Pressure Switches	34-44,87-89
Pressure Transmitters	34-37,61-67,69-73,87-89,102-109
Temperature	
Controllers	119-123
Switches	126-127,129-130
Indicators	349,351-353
Manometers	165-166,172-176,178-181
Panel Meters	125,338,349-353
Pressure Gages	84-86
DigiMag®	25
Temperature Switch Configuration Key	131
Timers	364,368-371
<b>DIN</b>	
Control Enclosures	338
<b>Displacer</b>	
Level Switches	320
<b>Displays</b>	<b>125,338,348-353</b>
<b>Disposable In-Line Filter</b>	<b>450</b>
<b>DPDT Low Differential Pressure Switches</b>	<b>52</b>
<b>Draft</b>	
Pressure Gages	20-21
<b>Drain</b>	
Pan Level	308
<b>Drip Pan Level</b>	<b>308</b>
<b>Duct Mount</b>	
Humidity Transmitters	224,226
Pressure Transmitters	66-67
Temperature Sensors	146
<b>Duotect® Switches</b>	<b>94</b>
<b>Duplexing Pump Controllers</b>	<b>336-338,352</b>
<b>Durablock® Gage/Manometers</b>	<b>29-30,184</b>
<b>Durablock® Solid Plastic Portable Gages</b>	<b>184</b>
<b>Dust Collector</b>	
Timer Controls	367-371
Valves	428-429
<b>E</b>	
<b>Electric</b>	
Actuator	416-417
Ball Valves	384-400,404-412
Bin Vibrator	340
Butterfly Valves	414-415
<b>Electromagnetic</b>	
Flow Transmitters	294
<b>Electromechanical Relays</b>	<b>355</b>
<b>Electronic Fan Speed Control</b>	<b>363</b>
<b>Enclosures</b>	
Controllers	338
Panel Meter	349
Solenoid Valves	367,427
<b>Energy Meter</b>	<b>295</b>
<b>Explosion-Proof</b>	
Ball Valves	384-400,404-412
Butterfly Valves	414-415
Current to Pressure Transducers	443
Differential Pressure Control	37,40,43
Differential Pressure Gage	24
Differential Pressure Switches	46,48,54-57
Differential	50
Differential Pressure Transmitter	65-66,70-73,75
Flow Switches	270-273
Humidity Transmitters	227
Level Switches	309-310,313,318,320,324-327
Position Indicators/Switches/Transmitters	435-438
Pressure Switches	90-94,96
Pressure Transmitters	104,106-109
Temperature Switches	132
Temperature Transmitters	135,227
Thermostats	132
<b>Extension Cables for Temperature Sensors</b>	<b>144</b>

	PAGE
<b>F</b>	
<b>Fan Speed Controllers</b>	<b>363</b>
<b>Filter</b>	
Accessories	456
Gages	20-21,25,29,33
<b>Filters</b>	<b>246-248,250-251,450</b>
<b>Fittings</b>	
Accessories	456
Bulk Head Connectors	430
Saddle	294
<b>Flame-Proof</b>	
Differential Pressure Control	37,40,43
Differential Pressure Gage	24
Differential Pressure Switches	46,48,50
Differential Pressure Transmitter	65
Low Differential Pressure Switches	48,50
Switches/Gages	40,43
<b>Flex-Tube® Manometers</b>	<b>30</b>
<b>Float Level Transmitters</b>	<b>333</b>
<b>Float Switch</b>	<b>309-319</b>
<b>Flotect® Switch</b>	<b>270-275,309-312</b>
<b>Flow</b>	<b>235-298</b>
Applications	242-244
Controllers	298
Data Loggers	193,288,290
Digital	
Paddlewheel	284
Energy Meter	295
Flow Switches	
Thermal	276
Flow Transmitters	
Electromagnetic	293
Remote Display	293
Thermal Energy	292-293
Global Valve Switch	279
Indicators	267-269,282-283
Switch Output	282-283,285-287
Transmitter Output	282-283,285-287
Magnetic Inductive	
Flow Sensor	291
Mass Flowmeters	296
Meters	193,246-254,256-261,264-266,285-289,290,295,297-298
Digital	193,288-290,297-298
Fluoropolymer	254
Glass	255-257
In-Line	249,252-254,257-260,262-265
Magnehelic®	261
Mass	297-298
Polycarbonate	246-247,253,258
Polysulfone	252,258
Purge	246-251
Rotatable Scale	257
Switch Output	280
Transmitter Output	280,295,298
Ultrasonic	193,288-290
Variable Area	246-257,266
Multi-Jet	
Water Meters	285-287
Multitube	
Variable Area	248
Orifice Plates	264-265
Pipe Fittings	294
Sensors	261,264-265,280-283,285-287,295
Electromagnetic	
Insertion	294
In-Line	262-263
Magnetic Inductive	291
Switches	270-280,282-283
Paddle	270-276
Shuttle/Piston	277-279
Technical Information	245
Totalizers	283,285-289
Transducers	282-284,291
Electromagnetic	294
In-Line	280,282-284,291,297
Indicating	282-283
Insertion	281,294
Paddlewheel	281-283
Ultrasonic	193,288-290,295
Transmitters	280
Electromagnetic	294
In-Line	280,282-284,291,297
Indicating	282-283
Insertion	281,294
Paddlewheel	281-283
Ultrasonic	193,288-290,295
<b>Flow Control</b>	
Actuators	416-417
Valves	384-400,402,404-412,414-415,420-423,431-432
<b>Flow Indicators/Controllers</b>	<b>338,352</b>
<b>Flow Sensor</b>	<b>262-263</b>
<b>Flow Stations</b>	<b>210-213</b>
<b>Flow Switches</b>	
Thermal	276

	PAGE
<b>Flow Totalizers</b>	<b>283,285-287,338,352</b>
Transducers	283
Transmitters	
In-Line	283
Indicating	283
<b>Flow Transmitters</b>	
Electromagnetic	
Thermal Energy	292-293
<b>Fluid Control</b>	
Actuators	416-417
Valves	384-399,404-423,425-430
<b>Fume Hood Monitors</b>	<b>216</b>
<b>G</b>	
<b>Gage Fluid</b>	<b>457</b>
<b>Gage Guards</b>	<b>452</b>
<b>Gage/Level Switches-Dial</b>	<b>20-39,40-44</b>
<b>Gages</b>	
Air Filter	20-21,25-30
Air Velocity	20-21,184-185,219-220
Dial	20-21,26-27,31-32,81-83
Differential Pressure	20-33,172-173,175-176,178-183
Digital	25,34-37,81,84-87,172-173,175-176,178-181
Draft	20-21,28-30,176,182-183
Low Pressure	20-21,81
Piston Type	32
Pressure	
Dial	
Single Pressure	81
Temperature	116-118
<b>Galvanic Barrier</b>	<b>366</b>
<b>Gas Analyzers</b>	<b>169,194</b>
<b>Gas Detectors</b>	
Carbon Dioxide	
Duct Mount	231
Wall Mount	227-231
Carbon Monoxide	232-233
Nitrogen Dioxide	232
<b>Gas Mass Flow</b>	<b>297-298</b>
<b>Gas Meter Flow</b>	<b>297</b>
<b>Gas Pressure</b>	
Kits	183
Manometer	184
Switches	54
<b>Globe Valves</b>	<b>418-422,432</b>
<b>Glossary</b>	<b>458-459</b>
<b>Graphical Display Data Logger</b>	<b>202</b>
<b>Ground Control</b>	<b>367</b>
<b>H</b>	
<b>Hand Pump</b>	<b>197-199</b>
Pneumatic	197-198
<b>Handheld Instruments</b>	
Air Quality	165-169,174,194
Air Velocity	168,170-171,175,185,191-192
Calibrators	196-197
Humidity	168-169
Pressure	172-176,178-181
<b>HART®</b>	
Communication Software	107
Position Indicators/Switches/Transmitters	436-438
Positioners	446
Pressure Transmitters	70-73,106-109
<b>Hazardous Rated</b>	
Actuators	416-417
Ball Valves	384-400,404-412
Butterfly Valves	414-415
Current to Pressure Transducers	441-443
Differential Pressure Switches	41,47,49,54-57
Flow Switches	270-273
Humidity Transmitters	227
Level Switches	309-310,313,318,320,325-327
Level Transmitters	328,330,334
Particulate	
Sensor	373-374
Transmitters	372
Position Indicators/Switches/Transmitters	435-438
Pressure	
Switches	47,49,90-94,96
Transmitters	69-75,104,108-110
Temperature	
Switches	132
Transmitters	135
Thermostats	132
<b>Hermetically Sealed</b>	<b>54,90-93,116,274,282,285-287,452</b>
Contacts	313
Reed Switch	277-278,312,314,440
Snap Switch	318,320
Switches	436-438
<b>Hi-Flow™</b>	<b>420-422</b>

	PAGE
<b>Hosing</b>	
Accessories	455
<b>Humidistat</b>	<b>221</b>
<b>Humidity</b>	
Accessories	
Radiation Shield	225
Controllers	221
Data Loggers	200-204
Handhelds	168-169
Indicators	200-201
Loggers/Recorders	200-204
Radiation Shield	225
Switches	221
Transmitters	222-227,230
Duct Mount	224
Indicating	222,224,227
Remote Mount	225-226
Wall Mount	222-223,230
<b>HVAC</b>	
Ball Valves	412
Flow Alarms	217
Mobile Application	166-167
Sensor	
Transmitters	223,233
Temperature	133
<b>Hydraulic</b>	
Calibration Hand Pump	198
Valves	413
<b>Hydronic Manometer</b>	
Water Meter	172-173,180
<b>Hygrometers</b>	<b>168-169</b>
<b>I</b>	
<b>I to P</b>	<b>441-443</b>
<b>Immersion</b>	
Temperature Sensors	146-147
<b>Indicating</b>	
Pressure Transmitters	34-36,70-73,76,80,102-103
<b>Indicators</b>	
Air Flow	246-260,266,268-269
Air Velocity	190-191,216,219
Annunciators	354
Differential Pressure	20-33,172-176,178-184
Flow	338,352
In-Line	258,260
Sight Flow	267-269
Totalizers	285
Ultrasonic	193,288-290,295
Variable Area	246-257
Totalizers	285-287
Flow Totalizers	286
Humidity	168-169,202,221
Level	307-308,338,352
Position	435-440
Process	125,338,348-354
Relative Humidity	125,221
Sight Flow	268-269,282-283
Temperature	116-118,125,127
Variable Area	246-257
Water Leak	308
Wind Speed	190-191
<b>Indoor Air Quality</b>	
Carbon Dioxide and Temperature Transmitters	228-230
Carbon Dioxide and Volatile Organic Compound (VOC)	231
Duct Mount	231
Wall Mount	231
Carbon Monoxide Transmitters	232-233
Humidity Transmitters	222-225
Nitrogen Dioxide Transmitters	232
<b>Intrinsically Safe</b>	
Barriers	365-366
Current to Pressure Transducers	441-443
Humidity Transmitters	227,366
Isolators	365-366
Level Transmitters	328,330
Particulate Sensors	372-374
Position Indicators/Switches/Transmitters	436-438
Pressure Transmitters	69,74,110
<b>IR Sensor</b>	
Temperature	137
<b>K</b>	
<b>Kits</b>	
Air Filter Gage/Switch	457
Air Velocity	168,175-177,184-185,190
Combustion	194-195
Portable Gage	20-21,176,183-185
Tachometer	195

	PAGE
<b>L</b>	
<b>LCD</b>	
Data Loggers	200-204
Indicators	350
Pressure Data Loggers	201
<b>Leak Detectors</b>	
Gas	195
Particulate	372-374
Water	308
<b>Level</b>	<b>299-340</b>
Applications	304-305
Bin Vibrators	339-340
Controllers	336-338
Indicators	306-308
Multi-Point	312,315-317
Sensors	309-325,328-335
Switches	309-314,326-327
Bin Level	321-325
Capacitive	321-322
Chamber Type	318
Diaphragm	326-327
Displacer	320
Float	309-319
Multi-Point	312,315-317,320
Optical	320
Paddle	324-325
Powder and Bulk	321-327
Tuning Fork	323
Vibrating Rod	322
Transducer	328-335
Transmitters	
Capacitive	332
Float	333
Indicating	334-335
Submersible	328-331
Ultrasonic	334-335
Water Detectors	308
<b>Level Indicators</b>	<b>306-308</b>
<b>Lift Station</b>	
Level Switches	319
Level Transmitters	330-331
Pump Controls	336-338,352
<b>Limit Controls</b>	<b>125</b>
<b>Limit Switches</b>	
Differential Pressure	34-36,45,47,49,51-57
Flow	270-280
Gas Pressure	54
Level	309-327
Pressure	45,47,49,51-57,87-98
Temperature	125-127,129,132
<b>Lin-E-Aire®</b>	<b>420-422</b>
<b>Liquid Level</b>	
Controllers	336-337
Indicators	267,306-308
Switches	309-321
Transmitters	328-335
<b>Liquid/Particle Filter</b>	<b>450</b>
<b>Looper Powered Indicators</b>	<b>353</b>
<b>Low Pressure Calibration Pumps</b>	<b>199</b>
<b>M</b>	
<b>Magnehelic®</b>	<b>20-21,64</b>
Mounting	23
Options	20-22
<b>Magnesense®</b>	<b>66-67</b>
<b>Manifold</b>	
1-Valve	431
2-Valve	433
3-Valve	433
5-Valve	434
<b>Manometers</b>	
Digital Handheld	172-176,178-181,194
Fluid Filled	183
Gage Fluid	457
Inclined	28-30
Inclined/Vertical	28-30,183
Portable	28,30,182-183
U-Tube	182-183
Well-Type	30
Hydronic	172-173,180
Inclined	30
Inclined/Vertical	30
<b>Mark</b>	
Position Indicators/Switches/Transmitters	436-438
<b>Mass Flowmeters and Controllers</b>	<b>297-298</b>
<b>Meters</b>	
Indoor Air Quality	168-169
Tachometer	195
<b>Mineral Insulated Temperature Sensors</b>	<b>139</b>
<b>Mini View Rite</b>	<b>307</b>
<b>Mini-Master® Flowmeter</b>	<b>250-251</b>
<b>Mini-Node™</b>	<b>361</b>
<b>Mini-Photohelic®</b>	<b>44</b>



	PAGE
<b>Minihelic® II</b>	<b>26-27</b>
<b>Mobile Application</b>	
HVAC	166-167
<b>Modbus® Communication</b>	<b>34-35,66,119-124,229,232,336-337</b>
Air Velocity Transmitter	218
Duct Mount	218
Carbon Dioxide Temperature and Relative Humidity	229
Carbon Monoxide	232
Temperature/Process Controller	119-124
<b>Monitors</b>	
Indoor Air Quality	169
Room Status	20-23,61,63
<b>Mounting Brackets</b>	<b>23,149,457</b>
<b>Multi-Function Meter</b>	<b>165</b>
<b>Multi-Jet Water Meters</b>	<b>285-287</b>
<b>N</b>	
<b>Needle Valves</b>	<b>431</b>
<b>Nitrogen Dioxide</b>	
BACnet Communication	232
Modbus® Communication	232
Transmitters	232
<b>Non-Contact</b>	
Temperature Sensor	137
<b>NSF Approved</b>	<b>285</b>
<b>Null Switches</b>	<b>52</b>
<b>O</b>	
<b>Occupancy Sensors</b>	<b>234</b>
Omnidirectional	234
<b>Oil Controls</b>	
Manifold	431,433-434
<b>One-Touch®</b>	<b>58</b>
<b>Open Channel Flow</b>	<b>338,352</b>
<b>Optical</b>	
Level Switches	320
<b>Orifice Plates</b>	<b>264-265</b>
<b>Outside Air</b>	
Humidity Radiation Shield	225
Humidity Transmitters	224-225
<b>P</b>	
<b>Paddle</b>	
Level Switches	324-325
Powder and Bulk	324
<b>Paddlewheel Transmitters</b>	<b>281,284</b>
<b>Panel Meters</b>	<b>338,348-352</b>
<b>Parameter Configuration Key</b>	<b>131</b>
<b>Particulate</b>	
Monitor	373
Sensors	374
Transmitters	372
<b>Penetration Probe Temperature Sensors</b>	<b>141</b>
<b>Perforated Cooling Towers</b>	<b>451</b>
<b>Photohelic®</b>	<b>38-43</b>
<b>Pipe Fittings</b>	<b>294</b>
<b>Piston Vibrators</b>	<b>339</b>
<b>Pitot Tubes</b>	<b>186-188,262-263</b>
Averaging	189,214-215
<b>Pneumatic</b>	
Actuators	416-417
Ball Valves	384-400,404-412
Butterfly Valves	414-415
Calibration Hand Pumps	197-198
Conveying	
Timer Boards	368-371
Fittings	456
Hand Pumps	197-198
<b>Pocket Wind Meters</b>	<b>191</b>
<b>Position</b>	
Indicators	435-440
Sensors	435-440
Switches	435-440
Transmitters	435-438
<b>Positioners</b>	<b>444-446</b>
Compact	446
Electro-Pneumatic	444-445
Linear	444,446
Pneumatic	444-445
Rotary	445
<b>Powder and Bulk</b>	
Level Switches	321-327
Level Transmitters	332
<b>Power</b>	
Supplies	360-362
Transformers	360-362
<b>Preciso® II</b>	<b>444-445</b>

	PAGE
<b>Pressure</b>	<b>1-110</b>
Applications	16-17
BACnet	66
Calibrators	172-173,175-176,179-181,197-199
Controllers	34-37,89,447-448
Data Loggers	201,203
Data Logging Software	33
Differential	
Gages	20-33
Switches	34-57
Transmitters	58-80
DigiHelic Links™	33
Indicating Switches	87-89
Indicating Transmitters	34-36,62-67,87-89,102-109
Regulators	201,447-448
Single Pressure	
Gages	
Dial	81
Digital	84-87
Switch/Gages	87-89
Switches	87-98
Transmitters	86-89,98-110
Snubbers	453
Switches	54
Digital	34-37,87-89
Indicating	34-44,87-89
Null	52
Submersible	97
Two-Stage	53,90-91,94
Water Pump	98
Transducers	61-80,88-89,99-105,110
Indicating	34-36,64-67,87-88,102-105
Sanitary	98
Transmitters	58-59,61-63,65,69-80,88-89,99-101,104,106-110
Indicating	34-36,64,66-67,87-88,102-105
Sanitary	98
Pressure/Temperature Data Logger	<b>201</b>
<b>Process</b>	
Alarm Switch Modules	354
Controllers	119-125
Current Switches	356-357
Current Transformers	359
Data Loggers	200-203
Fan Speed Controllers	363
Filter Gage	20-21,33
Loop Alarms	354
Panel Meters/Indicators	125,348-354
Particulate (Dust or Broken Bag) Sensors	373-374
Particulate (Dust or Broken Bag) Transmitter	372
SSR Monitors	361
Switches	354,368-371
Alarm	354
Timer Boards	368-371
Vibration Transmitter	363
<b>Process Control</b>	<b>341-376</b>
Applications	346-347
Current Monitoring	
Current Transformers	359
Current Transformers/Switches	358
Enclosures	376
Power Supplies	
24 AC-24 DC	361-362
Transformers	
120 VAC-24 VAC	360
<b>Pulse Valves</b>	<b>428-429</b>
<b>Pump</b>	
Calibration	197-199,336-338,352
<b>Purge Meters</b>	<b>246-251</b>
<b>Q</b>	
<b>Quadraplex Pump Controllers</b>	<b>338,352</b>
<b>Quick-View®</b>	<b>435</b>

	PAGE
<b>R</b>	
Radiation Shield	225
Rate-Master® Flowmeter	246-247,260
Recorders	200-204
Reference Tables	460-462
Regulators	447-448
Relative Humidity	
Controllers	221
Indicators	221
Switches	221
Transmitters	222-227
Relays	361
Electromechanical	355
Remote Display	293
Remote Mount	
Humidity Transmitters	226
RH	
Switches	221
Transmitters	222-227
Room Status Monitor	61
Rotometers	246-257
RTD	
Duct Mount	146
Immersion	146-147
Outside Air	148
Sensors	136-137,139-141,145-150
Transmitters	134
Wall Mount	145
<b>S</b>	
SAE	
Valve	413
Sanitary	
Ball Valves	390-391,408-409
Pressure Transmitters	98
Temperature Sensors	141
Selection Guide	
Air Quality	206-207
Flow	236-241
Level	300-303
Pressure	2-15
Process Control	342-345
Temperature	112-113
Test & Data	152-155
Valves	378-381
Self-Acting Temperature Control Valves	418-419
Sensors	
Air Flow	186-189,210-215,264-265
Air Velocity	186-189,210-215,262-265
Transmitters	217,219-220
Broken Bag	372-374
BTU	
Transmitters	295
Carbon Dioxide	
Transmitters	227-230
Carbon Dioxide and Volatile Organic Compound (VOC)	231
Duct Mount	231
Wall Mount	231
Carbon Dioxide Temperature and Relative Humidity	
BACnet Communication	229
Modbus® Communication	229
Carbon Monoxide	
BACnet Communication	232
Modbus® Communication	232
Transmitters	232-233
Current	
Switches	356-358
Transmitters	359
Differential Pressure	45,47,49,51-57
Transmitters	60-80
Flow	210-211,262-263
Meters	246-266
Switches	270-280,282
Transmitters	193,280-298
Humidity	
Transmitters	222-227
HVAC	
Occupancy	234
Level	309-335
Switches	309-327
Transmitters	328-335
Nitrogen Dioxide	
BACnet Communication	232
Modbus® Communication	232
Transmitters	232
Occupancy	234
Particulate	372-374
Position	435-440
Pressure	
Transmitters	34-36,77,98-110

	PAGE
Temperature	
Ambient Air	136-137,139-150
Duct Mount	146
Immersion	146-147
IR	137
Non-Contact	137
Outside Air	148-149
RTD	136-137,139-142,144-150
Surface	150
Switch	131
Thermocouple	136-137,139-142,144
Thermowells	117,143,147
Transducers	99,133-135,222-228,230
Transmitters	133-135,222-228,230
In-Line	297
Volatile Organic Compound (VOC)	
Duct Mount	231
Wall Mount	231
Wall Mount	145
Shock and Vibration Resistant	51,110,355
Shut-Off Valves	413
Sight Flow	
Indicators	267-271,282-283
Transmitters	282-283
Signal	
Conditioners	359,361
Converters	361
Generators	196
Single Pressure Gages	
Dial	81-83
Slack Tube® Manometer	183
Smart Programmable Panel Meters	348-349
Software	
DigiHelic® Controller	33
HART® Communication	107
Solenoid Valves	424-427
Enclosures	367,427
Timer	367
Spiral Cooling Towers	451
Steam Control	
Manifolds	433-434
Valves	420-422
Strap Wrench	452
Submersible	
Level Transmitters	328-331
Pressure Switches	97
Temperature Data Logger	200
Sump	
Level Switches	319
Surface	
Temperature Sensors	150
Surface Mount	
Temperature Sensors	150
Swing Vane Anemometer	190
Switch/Gages	34-44,87-89
Switches	
Air Flow	217
Bin Level	322-327
Current	356-358
Differential Pressure	34-57
Flow	270-280,282-283
Gas Pressure	54
Humidity	221
Level	308-327
Limit	
Air Flow	216-217,270-273,276,278-280
Gas Pressure	54
Pressure	45-55,57,87-98
Temperature	125-127,129,131-132,354
Position	435-440
Refrigeration	124,128
Relative Humidity	221
Single Pressure	87-98
Temperature	125-132,354
Switches/Gages	40

	PAGE
<b>T</b>	
<b>Tachometers</b>	<b>195,364</b>
<b>Technical Information</b>	
Flow	245
Glossary	458-459
Reference Tables	460-462
Temperature Sensors	136
Valves	383
<b>Temperature</b>	<b>111-150</b>
Applications	114-115
Control Valves	418-419
Controllers	119-130
Rail Mount	124
Data Loggers	200-204
Handhelds	165-169,171,174,191-192
Indicators	116-130,350-354
Loggers/Recorders	200-204
Panel Meters/Indicators	350-351
Sensors	136-137,139-142,143-150
Ambient Air	148-149
Averaging	149
Averaging Sensor Clip	149
Duct	146
Extension Cables	144
Immersion	146-147
IR	137
Mineral Insulated	139
Non-Contact	137
Outside Air	148-149
Penetration	141
RTD	136-137,139-142,144-150
Sanitary	141
Surface	150
Thermistor	146-147
Thermocouple	137,139-140,142,144
Weatherproof	141
Thermowells	117,143,147
Wall Mount	126-127,129-130,145,221
Switches	124-131,221
Digital Indicating	130
Digital Panel Mount	125
Indicating	118,124-130
Limit	126
Thermostat	132
Two-Stage	129
Temperature/Process Controller	119-123
Thermistors	146-148
Wall Mount	145
Thermometers	116,118
Dial	116
Digital	193
Glass	117
Remote Reading	118
Thermowells	117,143,147
Transmitter Output	118
Thermostats	132
Transmitters	133-135,217,222,224-227
Indicating	118
Weatherproof	134
Weatherproof (NEMA 4)	133
Wire	138
<b>Test &amp; Data</b>	<b>151-204</b>
Air Quality	165-169,174,194-195
Analyzers	
Flue Gas	194
Applications	156-157
Calibrators	196-199
Kits	174
Air Velocity	165,168,177,184-185,190-191
Gas Pressure	183,195
Portable Gage	184-185
RH	165,168
Universal Handheld	165-168,174
Leak Detectors	
Combustion	194
Gas	195
Pitot Tubes	186-187,189
Pumps	197-199
Temperature	193
Thermohygrometers	168-169
Ultrasonic Thickness Gage	289
<b>Testers</b>	<b>196</b>
<b>Thermal Energy</b>	<b>292-293</b>
<b>Thermistors</b>	
Averaging	149
Duct Mount	146
Immersion	146-147
Outside Air	148
Surface Mount	150
Wall Mount	145
<b>Thermo-Anemometers</b>	<b>167-168,170-171,192</b>
<b>Thermocouples</b>	<b>136-137,139-142,144,150</b>
<b>Thermocouples Transmitter</b>	<b>134</b>
<b>Thermohygrometers</b>	<b>165-166,168-169,174</b>

	PAGE
<b>Thermometers</b>	
Dial	116
Glass	117
<b>Thermostat</b>	<b>132</b>
<b>Thermowells</b>	<b>117,143,147</b>
<b>Timer Boards</b>	<b>368-371</b>
<b>Timer Controllers</b>	<b>368-371</b>
<b>Timers</b>	<b>364,367</b>
<b>Totalizing Meters</b>	
Flow	283,285-287,338,352
<b>Toxic Fluids Control</b>	
Manifold	433-434
<b>Trademarks</b>	<b>463</b>
<b>Transducer</b>	
Current to Pressure	441-443
Electro-Pneumatic	441
<b>Transformers</b>	<b>356</b>
AC Power	360
Current	359
<b>Transmitters</b>	
Air Velocity	219-220
Carbon Dioxide	227-230
Carbon Dioxide and Temperature	228-230
Carbon Dioxide and Volatile Organic Compound (VOC)	231
Duct Mount	231
Wall Mount	231
Carbon Dioxide Temperature and Relative Humidity	229-230
Carbon Monoxide	232-233
Differential Pressure	35-37,58-64,66-67,69-75,77-80
Paddlewheel	34
Differential Pressure Transmitter	65
Flow	193,280-283,285-295,297-298
Digital	284
Humidity	222-230
Duct Mount	224
Indicating	222,227
Remote Mount	226
Wall Mount	222-223
Humidity and Temperature	222-230
Level	328-335
Nitrogen Dioxide	232
Particulate	372-374
Position	435-438
Pressure	34-36,77,98-104,110
Indicating	87-88,102-103,105-109
Smart	
Pressure	105-109
Temperature	133-135,225-228
Indicating	118
Wall Mount	133
Vibration	363
Volatile Organic Compound (VOC)	231
Duct Mount	231
Wall Mount	231
<b>True RMS Current Transformer</b>	<b>359</b>
<b>Tubing</b>	
Accessories	455
<b>Tuning Fork</b>	
Level Switch	323
<b>U</b>	
<b>U-Tube Manometers</b>	<b>182-183</b>
<b>Ultra-Mag™</b>	<b>326-327</b>
<b>Ultra-View™ Flowmeter</b>	<b>252</b>
<b>Ultrasonic</b>	
Flowmeters	193,288-290,295
Level	
Transmitters	334-335
Ultrasonic Thickness Gage	289

	PAGE
<b>V</b>	
<b>Valves</b>	<b>377-448</b>
Actuated	384-391,400,404-412
Two-Piece	384-387
Actuators	416-417
Angle Seat	423
Applications	382
Ball	384-412,416-417
Automated	384-400,404-412,416-417
Flanged	392-393,398-399,410-411
Manual	384-399,401-411
Mini	403
NPT	384-389,396-397,401-402,404-407
Regulators and Lubricators	447-448
Sweat	402
Socket Weld	394-395
Three-Piece	388-391,394-397
Three-Way	404-412
Tri-Clamp	390-391,408-409
Two-Piece	384-387,392-393,398-399,401
Two-Way	384-402
Uni-Flange	402
V-Ball	396-399
Butterfly	413-417
Automated	414-417
Lug	414-415
Manual	414-415
Two-Way	413-415
Wafer	414-415
Check	430-431
Control	418-422
Controllers	193,290
Current to Pressure Transducers	32-34,441-443
Diaphragm	428-429
Electric Actuated	384-400,404-412,414-415
Enclosures	367,412,427
Globe	418-422,432
Manifold	431,433-434
Needle	431
Pneumatic Actuated	384-400,404-412,414-415,420-423
Repair Kit	417
Position Indicators/Switches/Transmitters	435-440
Positioners	444-446
Pulse	428-429
SAE	413
Solenoids	367,424-427
Strainer	432
Technical Information	383
Temperature Control	418-419
Volume Booster	447
<b>Vaneometers™</b>	<b>190</b>
<b>Variable Area</b>	
Flowmeters	246-257
<b>Venturi Meter/Gage</b>	<b>261</b>
<b>Vibrating Rod</b>	
Level Switch	322
<b>Vibration</b>	
Transmitters	363
<b>Vibration Resistant</b>	<b>57,83,90-91,93-94,100-101,262-263,413,431,439,443</b>
<b>Vibrators</b>	<b>339-340</b>
<b>View-Rite</b>	<b>306-307</b>
<b>Visi-Float® Flowmeter</b>	<b>248-249</b>
<b>Volatile Organic Compound (VOC)</b>	
Transmitters	231
Duct Mount	231
Wall Mount	231

	PAGE
<b>W</b>	
<b>Wall Mount</b>	
Carbon Dioxide and Temperature Transmitters	228-230
European	228
North American	228
Carbon Dioxide Transmitter	228-229
European	228-229
North American	228-229
Carbon Dioxide, Temperature and Relative Humidity	
European	230
North American	230
Humidity and Temperature Transmitters	222
Humidity Transmitters	222
Occupancy Sensor	234
Temperature Sensors	145
Temperature Transmitters	133
<b>Water</b>	
Control Manifold	433-434
Detectors	308
Meters	285-287
Pump Pressure Switches	98
<b>Weatherproof Enclosures</b>	<b>338</b>
<b>Well Level Transmitter</b>	<b>329</b>
<b>Wet/Wet</b>	
Differential Pressure Switches	56-57
Differential Pressure Transmitters	70-73,75-80
<b>WI-FI</b>	
Data Loggers	204
<b>Wind Meters</b>	<b>190-191</b>
<b>Wind Speed Indicators</b>	<b>190-191</b>
<b>Wireless</b>	<b>165-168,174</b>
Data Loggers	204
Pitot Tubes	167
Position Indicators/Switches/Transmitters	436-438
<b>Z</b>	
<b>Zener Barriers</b>	<b>365</b>



# PRESSURE CONVERSION CHART

in/H <sub>2</sub> O	P.S.I.	in/Hg	mm/H <sub>2</sub> O	mm/Hg	kg/cm <sup>2</sup>	bar	mbar	Pa	kPa
.1	.0036	.0073	2.534	.1863	.0002	.0002	.2482	24.82	.0248
.2	.0072	.0146	5.067	.3726	.0005	.0005	.4964	49.64	.0496
.4	.0144	.0293	10.13	.7452	.0010	.0010	.9928	99.28	.0993
.6	.0216	.0440	15.20	1.118	.0015	.0015	1.489	148.9	.1489
.8	.0288	.0588	20.34	1.496	.0020	.0020	1.992	199.2	.1992
1.0	.361	.0735	25.41	1.868	.0025	.0025	2.489	248.9	.2489
2	.722	.1470	50.81	3.736	.0051	.0050	4.978	497.8	.4978
3	1.083	.2205	76.22	5.604	.0076	.0075	7.467	746.7	.7476
4	1.444	.2940	101.62	7.472	.0102	.0099	9.956	995.6	.9956
5	1.804	.3673	127.0	9.335	.0127	.0124	12.44	1244	1.244
6	2.165	.4408	152.4	11.203	.0152	.0149	14.93	1493	1.493
7	2.526	.5143	177.8	13.072	.0178	.0174	17.42	1742	1.742
8	2.887	.5878	203.2	14.940	.0203	.0199	19.90	1990	1.990
9	3.248	.6613	228.6	16.808	.0228	.0224	22.39	2239	2.239
10	3.609	.7348	254.0	18.676	.0254	.0249	24.88	2488	2.488
11	3.970	.8083	279.4	20.544	.0279	.0274	27.37	2737	2.737
12	4.331	.8818	304.8	22.412	.0304	.0299	29.86	2986	2.986
13	4.692	.9553	330.2	24.280	.0330	.0324	32.35	3235	3.235
14	5.053	1.029	355.6	26.148	.0355	.0348	34.84	3484	3.484
15	5.414	1.102	381.0	28.016	.0381	.0373	37.33	3733	3.733
16	5.774	1.176	406.4	29.879	.0406	.0398	39.81	3981	3.981
17	6.136	1.249	431.8	31.752	.0431	.0423	42.31	4231	4.231
18	6.496	1.322	457.2	33.616	.0457	.0448	44.79	4479	4.479
19	6.857	1.396	482.6	35.484	.0482	.0473	47.28	4728	4.728
20	7.218	1.470	508.0	37.352	.0507	.0498	49.77	4977	4.977
21	7.579	1.543	533.4	39.22	.0533	.0523	52.26	5226	5.226
22	7.940	1.616	558.8	41.09	.0558	.0547	54.74	5474	5.474
23	8.301	1.690	584.2	42.96	.0584	.0572	57.23	5723	5.723
24	8.662	1.764	609.6	44.82	.0609	.0597	59.72	5972	5.972
25	9.023	1.837	635.0	46.69	.0634	.0622	62.21	6221	6.221
26	9.384	1.910	660.4	48.56	.0660	.0647	64.70	6470	6.470
27	9.745	1.984	685.8	50.43	.0685	.0672	67.19	6719	6.719
28	10.107	2.056	710.8	52.26	.0710	.0696	69.64	6964	6.964
29	1.040	2.132	736.8	54.18	.0736	.0722	72.19	7219	7.219
30	1.083	2.205	762.2	56.04	.0761	.0747	74.67	7467	7.467
31	1.119	2.278	787.5	57.91	.0787	.0772	77.15	7715	7.715
32	1.155	2.352	812.8	59.77	.0812	.0796	79.63	7963	7.963
33	1.191	2.425	838.2	61.63	.0837	.0821	82.12	8212	8.212
34	1.227	2.498	863.5	63.49	.0862	.0846	84.60	8460	8.460
35	1.263	2.571	888.9	65.36	.0888	.0871	87.08	8708	8.708
36	1.299	2.645	914.2	67.22	.0913	.0896	89.56	8956	8.956
37	1.335	2.718	939.5	69.08	.0938	.0920	92.04	9204	9.204
38	1.371	2.791	964.9	70.95	.0964	.0945	94.53	9453	9.453
39	1.408	2.865	990.9	72.86	.0990	.0971	97.08	9708	9.708
40	1.444	2.940	1016	74.72	.1015	.0996	99.56	9956	9.956
41	1.480	3.013	1042	76.59	.1040	.1020	102.0	10204	10.20
42	1.516	3.086	1067	78.45	.1066	.1045	104.5	10452	10.45
43	1.552	3.160	1092	80.31	.1091	.1070	107.0	10701	10.70
44	1.588	3.233	1118	82.18	.1116	.1095	109.5	10949	10.95
45	1.624	3.306	1143	84.04	.1142	.1120	112.0	11197	11.20
46	1.660	3.378	1168	85.90	.1167	.1144	114.5	11445	11.44
47	1.696	3.453	1194	87.76	.1192	.1169	116.9	11694	11.69
48	1.732	3.526	1219	89.63	.1218	.1194	119.4	11942	11.94
49	1.768	3.600	1244	91.49	.1243	.1219	121.9	12190	12.19
50	1.804	3.673	1270	93.35	.1268	.1244	124.4	12438	12.44
51	1.841	3.748	1296	95.27	.1294	.1269	126.9	12693	12.69
52	1.877	3.822	1321	97.13	.1320	.1294	129.4	12941	12.94
53	1.913	3.895	1346	98.99	.1345	.1319	131.9	13190	13.19
54	1.949	3.968	1372	100.8	.1370	.1344	134.4	13438	13.44
55	1.985	4.041	1397	102.7	.1395	.1369	136.9	13686	13.69
56	2.021	4.115	1422	104.6	.1421	.1393	139.3	13934	13.93
57	2.057	4.188	1448	106.4	.1446	.1418	141.8	14182	14.18
58	2.093	4.261	1473	108.3	.1471	.1443	144.3	14431	14.43
59	2.129	4.335	1498	110.2	.1497	.1468	146.8	14679	14.68
60	2.165	4.408	1524	112.0	.1522	.1493	149.3	14927	14.93
61	2.202	4.483	1550	113.9	.1548	.1518	151.8	15182	15.18
62	2.238	4.556	1575	115.8	.1573	.1543	154.3	15430	15.43
63	2.274	4.630	1600	117.7	.1599	.1568	156.8	15679	15.68
64	2.310	4.703	1626	119.5	.1624	.1593	159.3	15927	15.93
65	2.346	4.776	1651	121.4	.1649	.1618	161.8	16175	16.18
66	2.382	4.850	1676	123.3	.1674	.1642	164.2	16423	16.42
67	2.418	4.923	1702	125.1	.1700	.1667	166.7	16672	16.67
68	2.454	4.996	1727	127.0	.1725	.1692	169.2	16920	16.92
69	2.490	5.070	1752	128.8	.1750	.1717	171.7	17168	17.17
70	2.526	5.143	1778	130.7	.1776	.1742	174.2	17416	17.42
71	2.562	5.216	1803	132.6	.1801	.1766	176.6	17664	17.66
72	2.598	5.290	1828	134.4	.1826	.1791	179.1	17912	17.91
73	2.635	5.365	1854	136.2	.1852	.1817	181.7	18168	18.17
74	2.671	5.438	1880	138.2	.1878	.1842	184.2	18416	18.42
75	2.707	5.511	1905	140.1	.1903	.1866	186.6	18664	18.66
76	2.743	5.585	1930	141.9	.1928	.1891	189.1	18912	18.91
77	2.779	5.658	1956	143.8	.1954	.1916	191.6	19160	19.16
78	2.815	5.731	1981	145.7	.1979	.1941	194.1	19409	19.41
79	2.851	5.805	2006	147.5	.2004	.1966	196.6	19657	19.66
80	2.887	5.878	2032	149.4	.2030	.1991	199.1	19905	19.90
81	2.923	5.951	2057	151.2	.2055	.2015	201.5	20153	20.15
82	2.959	6.024	2082	153.1	.2080	.2040	204.0	20402	20.40
83	2.996	6.100	2108	155.0	.2106	.2066	206.6	20657	20.66
84	3.032	6.173	2134	156.9	.2131	.2091	209.1	20905	20.90
85	3.068	6.246	2159	158.8	.2157	.2115	211.5	21153	21.15
86	3.104	6.320	2184	160.6	.2182	.2140	214.0	21401	21.40
87	3.140	6.393	2210	162.5	.2207	.2165	216.5	21650	21.65
88	3.176	6.466	2235	164.4	.2232	.2190	219.0	21900	21.90
89	3.212	6.540	2260	166.2	.2258	.2215	221.5	22146	22.15
90	3.248	6.613	2286	168.1	.2283	.2239	223.9	22394	22.39
91	3.284	6.686	2311	169.9	.2309	.2264	226.4	22642	22.64
92	3.320	6.760	2336	171.8	.2334	.2289	228.9	22890	22.89
93	3.356	6.833	2362	173.7	.2359	.2314	231.4	23139	23.14
94	3.392	6.906	2387	175.5	.2384	.2339	233.9	23387	23.39
95	3.429	6.981	2413	177.4	.2410	.2364	236.4	23642	23.64
96	3.465	7.055	2438	179.3	.2436	.2389	238.9	23890	23.89
97	3.501	7.128	2464	181.2	.2461	.2414	241.4	24138	24.14
98	3.537	7.201	2489	183.0	.2486	.2439	243.9	24387	24.39
99	3.573	7.275	2514	184.9	.2512	.2464	246.4	24635	24.64
100	3.609	7.348	2540	186.8	.2537	.2488	248.8	24883	24.88

P.S.I.	in/H <sub>2</sub> O	in/Hg	mm/H <sub>2</sub> O	mm/Hg	kg/cm <sup>2</sup>	bar	mbar	Pa	kPa
1.0	27.71	2.036	703.1	51.75	.0703	.0689	68.95	6895	6.895
1.1	30.45	2.240	773.4	56.89	.0773	.0758	75.84	7584	7.584
1.2	33.22	2.443	843.7	62.06	.0844	.0827	82.74	8274	8.274
1.3	35.98	2.647	914.0	67.23	.0914	.0896	89.63	8963	8.963
1.4	38.75	2.850	984.3	72.40	.0984	.0965	96.52	9652	9.652
1.5	41.52	3.054	1054.6	77.57	.1055	.1034	103.4	10340	10.34
1.6	44.29	3.258	1124.9	82.74	.1125	.1103	110.3	11030	11.03
1.7	47.06	3.461	1195.2	87.92	.1195	.1172	117.2	11720	11.72
1.8	49.82	3.665	1265.5	93.09	.1266	.1241	124.1	12410	12.41
1.9	52.59	3.868	1335.8	98.26	.1336	.1310	131.0	13100	13.10
2.0	55.36	4.072	1406.1	103.4	.1406	.1379	137.9	13790	13.79
2.1	58.13	4.276	1476.4	108.6	.1476	.1448	144.8	14480	14.48
2.2	60.90	4.479	1546.7	113.8	.1547	.1517	151.7	15170	15.17
2.3	63.67	4.683	1617.0	118.9	.1617	.1586	158.6	15860	15.86
2.4	66.43	4.886	1687.3	124.1	.1687	.1655	165.5	16550	16.55
2.5	69.20	5.090	1757.6	129.3	.1758	.1724	172.4	17240	17.24
2.6	71.97	5.294	1827.9						

# *Dwyer*®

**Manufacturing Excellence Since 1931**

pressure | temperature | test & data | air quality

flow | level | process control | valves

Phone: (800) 876-0036

Fax: (847) 356-0747

# 2020

Distributed by: <https://www.mmcontrol.com/Dwyer.php>