



94-01
(Full Internal Port)
MODEL
694-01
(Reduced Internal Port)

Combination Pressure Reducing and Surge Control Valve



- Sensitive and Accurate Pressure Control
- Easy Adjustment and Maintenance
- Tamper Resistant
- Optional Check Feature
- Fully Supported Frictionless Diaphragm

The Cla-Val Model 94-01/694-01 Combination Pressure Reducing and Surge Control Valve automatically reduces a higher inlet pressure to a steady lower downstream pressure, regardless of changing flow rate and/or varying inlet pressure. This valve is an accurate, pilot-operated control valve capable of holding downstream pressure to a pre-determined limit. When downstream pressure rapidly exceeds the pressure setting of the pressure reducing control pilot, the surge pilot (CRL) will open quickly to prevent a rapid pressure rise downstream. If a check feature is added, and a pressure reversal occurs, the downstream pressure is admitted in the main valve cover chamber closing the valve to prevent return flow.

Schematic Diagram

Item	Description
1	100-01 Hytrol (Main Valve)
2	X58C Restriction Assembly
3	CRD Pressure Reducing Control
4	CRL Pressure Relief Control

Optional Features

Item	Description
A	X46A Flow Clean Strainer
B	CK2 (Isolation Valve)
C	CV Flow Control (Closing)*
D	Check Valves with Isolation Valve
F	Remote Pilot Sensing
P	X141 Pressure Gauge
S	CV Speed Control (Opening)
V	X101 Valve Position Indicator
Y	X43 "Y" Strainer

*The closing speed control (optional) on this valve should always be open at least three (3) turns off its seat.

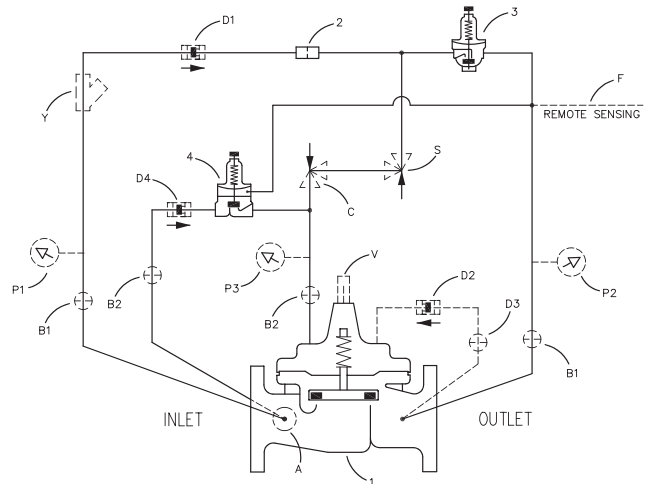

Typical Application

Should the downstream pressure suddenly increase above the setting of the pressure reducing control due to on-off operation of two or more downstream systems, the Surge Control tracks rapidly enough to prevent high pressure surges from entering any of the downstream systems, when any one of the downstream systems is rapidly closed off. The typical combination pressure reducing and surge control valve station uses Model 94-01BY/694-01BY to control surges in downstream piping as remote control valves change from one downstream zone to another. Surge Control is set approximately 10 psi above Pressure Reducing Control to prevent high pressure surge entering other downstream zones.

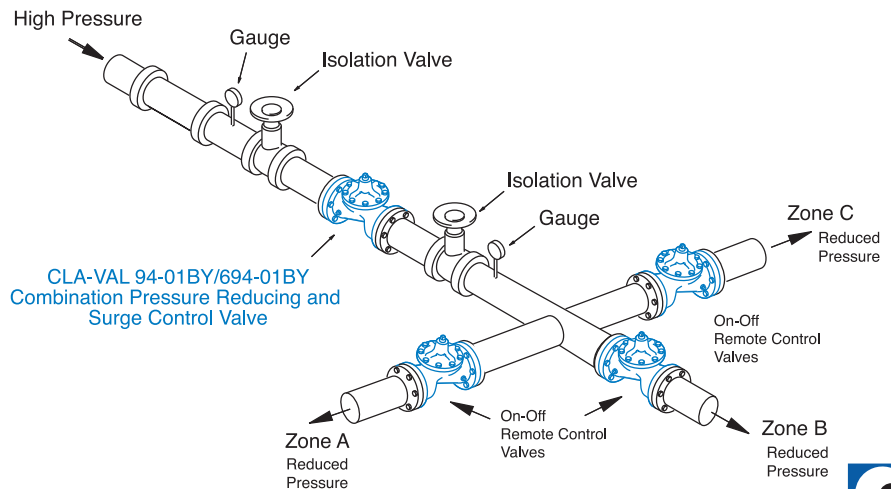

Model 94-01 (Uses Basic Valve Model 100-01)

Pressure Ratings (Recommended Maximum Pressure - psi)

Valve Body & Cover		Pressure Class				
		Flanged			Grooved	Threaded
Grade	Material	ANSI Standards*	150 Class	300 Class	300 Class	End‡ Details
ASTM A536	Ductile Iron	B16.42	250	400	400	400
ASTM A216-WCB	Cast Steel	B16.5	285	400	400	400
ASTM B62	Bronze	B16.24	225	400	400	400

Note: * ANSI standards are for flange dimensions only.
 Flanged valves are available faced but not drilled.
 ‡ End Details machined to ANSI B2.1 specifications.
Valves for higher pressure are available; consult factory for details

Materials

Component	Standard Material Combinations		
Body & Cover	Ductile Iron	Cast Steel	Bronze
Available Sizes	1" - 36"	1" - 16"	1" - 16"
Disc Retainer & Diaphragm Washer	Cast Iron	Cast Steel	Bronze
Trim: Disc Guide, Seat & Cover Bearing	Bronze is Standard Stainless Steel is Optional		
Disc	Buna-N® Rubber		
Diaphragm	Nylon Reinforced Buna-N® Rubber		
Stem, Nut & Spring	Stainless Steel		

For material options not listed, consult factory.
 Cla-Val manufactures valves in more than 50 different alloys.

Dimensions
(In inches)

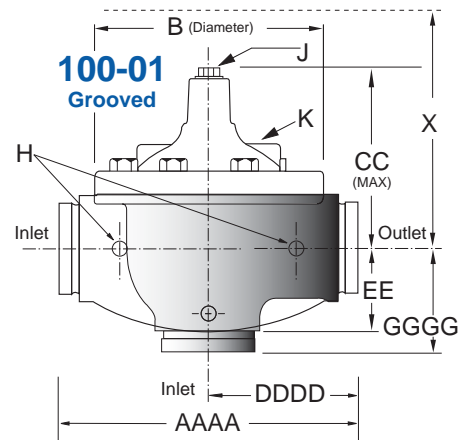
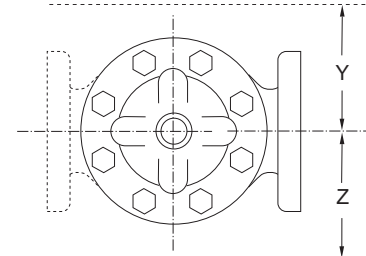
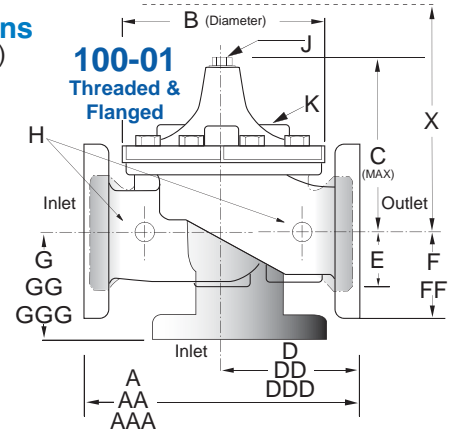

Model 94-01 Dimensions (In Inches)

Valve Size (Inches)	1	1 1/4	1 1/2	2	2 1/2	3	4	6	8	10	12	14	16	18	20	24	30	36
A Threaded	7.25	7.25	7.25	9.38	11.00	12.50	—	—	—	—	—	—	—	—	—	—	—	—
AA 150 ANSI	—	—	8.50	9.38	11.00	12.00	15.00	20.00	25.38	29.75	34.00	39.00	41.38	46.00	52.00	61.50	63.00	76.00
AAA 300 ANSI	—	—	9.00	10.00	11.62	13.25	15.62	21.00	26.38	31.12	35.50	40.50	43.50	47.64	53.62	63.24	64.50	76.00
AAAA Grooved End	—	—	8.50	9.00	11.00	12.50	15.00	20.00	25.38	—	—	—	—	—	—	—	—	—
B Dia.	5.62	5.62	5.62	6.62	8.00	9.12	11.50	15.75	20.00	23.62	28.00	32.75	35.50	41.50	45.00	53.16	56.00	66.00
C Max.	5.50	5.50	5.50	6.50	7.56	8.19	10.62	13.38	16.00	17.12	20.88	24.19	25.00	39.06	41.90	43.93	54.60	61.50
CC Max. Grooved End	—	—	4.75	5.75	6.88	7.25	9.31	12.12	14.62	—	—	—	—	—	—	—	—	—
D Threaded	3.25	3.25	3.25	4.75	5.50	6.25	—	—	—	—	—	—	—	—	—	—	—	—
DD 150 ANSI	—	—	4.00	4.75	5.50	6.00	7.50	10.00	12.69	14.88	17.00	19.50	20.81	—	—	30.75	—	—
DDD 300 ANSI	—	—	4.25	5.00	5.88	6.38	7.88	10.50	13.25	15.56	17.75	20.25	21.62	—	—	31.62	—	—
DDDD Grooved End	—	—	—	4.75	—	6.00	7.50	—	—	—	—	—	—	—	—	—	—	—
E	1.12	1.12	1.12	1.50	1.69	2.06	3.19	4.31	5.31	9.25	10.75	12.62	15.50	12.95	15.00	17.75	21.31	24.56
EE Grooved End	—	—	2.00	2.50	2.88	3.12	4.25	6.00	7.56	—	—	—	—	—	—	—	—	—
F 150 ANSI	—	—	2.50	3.00	3.50	3.75	4.50	5.50	6.75	8.00	9.50	10.50	11.75	15.00	16.50	19.25	22.50	25.60
FF 300 ANSI	—	—	3.06	3.25	3.75	4.13	5.00	6.25	7.50	8.75	10.25	11.50	12.75	15.00	16.50	19.25	24.00	25.60
G Threaded	1.88	1.88	1.88	3.25	4.00	4.50	—	—	—	—	—	—	—	—	—	—	—	—
GG 150 ANSI	—	—	4.00	3.25	4.00	4.00	5.00	6.00	8.00	8.62	13.75	14.88	15.69	—	—	22.06	—	—
GGG 300 ANSI	—	—	4.25	3.50	4.31	4.38	5.31	6.50	8.50	9.31	14.50	15.62	16.50	—	—	22.90	—	—
GGGG Grooved End	—	—	—	3.25	—	4.25	5.00	—	—	—	—	—	—	—	—	—	—	—
H NPT Body Tapping	.375	.375	.375	.375	.50	.50	.75	.75	1	1	1	1	1	1	1	1	2	2
J NPT Cover Center Plug	.25	.25	.25	.50	.50	.50	.75	.75	1	1	1.25	1.5	2	1.5	1.5	1.5	2	2
K NPT Cover Tapping	.375	.375	.375	.375	.50	.50	.75	.75	1	1	1	1	1	1	1	1	2	2
Stem Travel	0.4	0.4	0.4	0.6	0.7	0.8	1.1	1.7	2.3	2.8	3.4	4.0	4.5	5.1	5.63	6.75	7.5	8.5
Approx. Ship Wt. Lbs.	15	15	15	35	50	70	140	285	500	780	1165	1600	2265	2982	3900	6200	7703	11720
X Pilot System	11	11	11	13	14	15	17	29	31	33	36	40	40	43	47	68	79	85
Y Pilot System	9	9	9	9	10	11	12	20	22	24	26	29	30	32	34	39	40	45
Z Pilot System	9	9	9	9	10	11	12	20	22	24	26	29	30	32	34	39	42	47

Note: The top two flange holes on valve size 36 are threaded to 1 1/2"-6 UNC.

Model 694-01 (Uses Basic Valve Model 100-20)

Dimensions
(In inches)

Pressure Ratings (Recommended Maximum Pressure - psi)

Valve Body & Cover		Pressure Class		
		Flanged		
Grade	Material	ANSI Standards*	150 Class	300 Class
ASTM A536	Ductile Iron	B16.42	250	400
ASTM A216-WCB	Cast Steel	B16.5	285	400
ASTM B62	Bronze	B16.24	225	400

Note: * ANSI standards are for flange dimensions only.
Flanged valves are available faced but not drilled.
Valves for higher pressure are available; consult factory for details

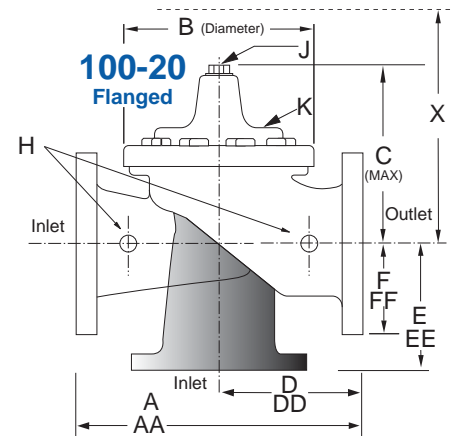

Materials

Component	Standard Material Combinations		
Body & Cover	Ductile Iron	Cast Steel	Bronze
Available Sizes	3" - 48"	3" - 16"	3" - 16"
Disc Retainer & Diaphragm Washer	Cast Iron	Cast Steel	Bronze
Trim: Disc Guide, Seat & Cover Bearing	Bronze is Standard Stainless Steel is Optional		
Disc	Buna-N® Rubber		
Diaphragm	Nylon Reinforced Buna-N® Rubber		
Stem, Nut & Spring	Stainless Steel		

For material options not listed, consult factory.
Cla-Val manufactures valves in more than 50 different alloys.

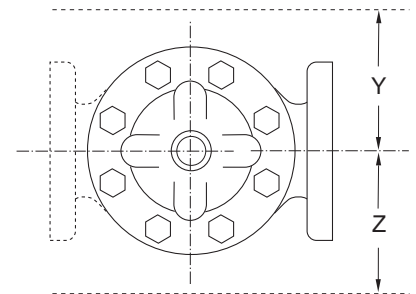

Model 694-01 Dimensions (In Inches)

Valve Size (Inches)	3	4	6	8	10	12	14	16	18	20	24	30	36	42	48
A 150 ANSI	10.25	13.88	17.75	21.38	26.00	30.00	34.25	35.00	42.12	48.00	48.00	63.25	65.00	76.00	94.50
AA 300 ANSI	11.00	14.50	18.62	22.38	27.38	31.50	35.75	36.62	43.63	49.62	49.75	63.75	67.00	76.00	94.50
B Dia.	6.62	9.12	11.50	15.75	20.00	23.62	27.47	28.00	35.44	35.44	35.44	53.19	56.00	66.00	66.00
C Max.	7.00	8.62	11.62	15.00	17.88	21.00	20.88	25.75	25.00	31.00	31.00	43.94	54.60	61.50	61.50
D 150 ANSI	—	6.94	8.88	10.69	CF*	CF*	CF*	CF*	CF*	CF*	CF*	—	—	—	—
DD 300 ANSI	—	7.25	9.38	11.19	CF*	CF*	CF*	CF*	CF*	CF*	CF*	—	—	—	—
E 150 ANSI	—	5.50	6.75	7.25	CF*	CF*	CF*	CF*	CF*	CF*	CF*	—	—	—	—
EE 300 ANSI	—	5.81	7.25	7.75	CF*	CF*	CF*	CF*	CF*	CF*	CF*	—	—	—	—
F 150 ANSI	3.75	4.50	5.50	6.75	8.00	9.50	11.00	11.75	15.88	14.56	17.00	19.88	25.50	28.00	31.50
FF 300 ANSI	4.12	5.00	6.25	7.50	8.75	10.25	11.50	12.75	15.88	16.06	19.00	22.00	27.50	28.00	31.50
H NPT Body Tapping	.375	.50	.75	.75	1	1	1	1	1	1	1	1	2	2	2
J NPT Cover Center Plug	.50	.50	.75	.75	1	1	1.25	1.25	2	2	2	2	2	2	2
K NPT Cover Tapping	.375	.50	.75	.75	1	1	1	1	1	1	1	1	2	2	2
Stem Travel	0.6	0.8	1.1	1.7	2.3	2.8	3.4	3.4	4.5	4.5	4.5	6.5	7.5	8.5	8.5
Approx. Ship Wt. Lbs.	45	85	195	330	625	900	1250	1380	1500	2551	2733	6500	8545	12450	13100
X Pilot System	13	15	27	30	33	36	36	41	40	46	55	68	79	85	86
Y Pilot System	10	11	18	20	22	24	26	26	30	30	30	39	40	45	47
Z Pilot System	10	11	18	20	22	24	26	26	30	30	30	39	42	47	49

*Consult Factory

Note: The top two flange holes on valve sizes 36 thru 48 are threaded to 1 1/2"-6 UNC.

94-01 Valve Selection	100-01 Pattern: Globe (G), Angle (A), End Connections: Threaded (T), Grooved (GR), Flanged (F) Indicate Available Sizes																		
	Inches	1	1½	1½	2	2½	3	4	6	8	10	12	14	16	18	20	24	30	36
	mm	25	32	40	50	65	80	100	150	200	250	300	350	400	450	500	600	750	900
Basic Valve 100-01	Pattern	G, A	G, A	G, A	G, A	G, A	G, A	G, A	G, A	G, A	G, A	G, A	G, A	G, A	G	G	G, A	G	G
	End Detail	T	T	T, F, Gr*	T, F, Gr	T, F, Gr*	T, F, Gr	F, Gr	F, Gr*	F, Gr*	F	F	F	F	F	F	F	F	F
Suggested Flow (gpm)	Maximum	55	93	125	210	300	460	800	1800	3100	4900	7000	8400	11000	14000	17000	25000	42000	50000
	Maximum Intermittent	68	120	160	260	370	580	990	2250	3900	6150	8720	10540	13700	17500	21700	31300	48000	62500
	Minimum	1	1	1	1	2	2	4	10	15	35	50	70	95	120	150	275	450	650
Suggested Flow (Liters/Sec)	Maximum	3.5	6	8	13	19	29	50	113	195	309	442	530	694	883	1073	1577	2650	3150
	Maximum Intermittent	4.3	7.6	10	16	23	37	62	142	246	387	549	664	863	1104	1369	1972	3028	3940
	Minimum	.03	.03	.03	.06	.09	0.13	0.25	0.63	0.95	2.2	3.2	4.4	6.0	7.6	9.5	17.4	28.4	41.0

100-01 Series is the full internal port Hytrol. For Lower Flows Consult Factory *Globe Grooved Only

694-01 Valve Selection	100-20 Pattern: Globe (G), Angle (A), End Connections: Flanged (F) Indicate Available Sizes															
	Inches	3	4	6	8	10	12	14	16	18	20	24	30	36	42	48
	mm	80	100	150	200	250	300	350	400	450	500	600	750	900	1000	1200
Basic Valve 100-20	Pattern	G	G, A	G, A	G, A	G	G	G	G	G	G	G	G	G	G	G
	End Detail	F	F	F	F	F	F	F	F	F	F	F	F	F	F	F
Suggested Flow (gpm)	Maximum	260	580	1025	2300	4100	6400	9230	9230	16500	16500	16500	28000	33500	33500	33500
	Minimum	1	2	4	10	15	35	50	50	95	95	95	275	450	450	450
Suggested Flow (Liters/Sec)	Maximum	16	37	65	145	258	403	581	581	1040	1040	1040	1764	2115	2115	2115
	Minimum	.06	.13	.25	.63	.95	2.2	3.2	3.2	6.0	6.0	6.0	17.4	28.4	41.0	41.0

100-20 Series is the reduced internal port size version of the 100-01 Series. For Lower Flows Consult Factory

Many factors should be considered in sizing pressure reducing valves including inlet pressure, outlet pressure and flow rates. For sizing questions or cavitation analysis, consult Cla-Val with system details.

Pilot System Specifications

Adjustment Ranges

CRD	CRL
2 to 30 psi	0 to 75 psi
15 to 75 psi	20 to 105 psi*
20 to 105 psi	20 to 200 psi
30 to 300 psi*	100 to 300 psi

*Supplied unless otherwise specified
Other ranges available, please consult factory.

Temperature Range

Water: to 180°F

Temperature Range

Water: to 180°F

Materials

Standard Pilot System Materials
Pilot Control: Bronze ASTM B62
Trim: Stainless Steel Type 303
Rubber: Buna-N® Synthetic Rubber

Optional Pilot System Materials

Pilot Systems are available with optional Aluminum, Stainless Steel, Monel or Cast Steel materials.
Note: Available with remote sensing control.

When Ordering, Please Specify

1. Catalog No. 94-01 or No. 694-01
2. Valve Size
3. Pattern - Globe or Angle
4. Pressure Class
5. Threaded or Flanged
6. Trim Material
7. Adjustment Range
8. Desired Options
9. When Vertically Installed