

4100 SERIES



BOILER FEED PUMPS STEEL TANK

ENERGY EFFICIENT DESIGN, PROVEN PERFORMANCE AND THE RIGHT SIZE FOR YOUR APPLICATION

Sterlco® Boiler Feed Pumps set new standards of performance. Reliable and efficient, each unit features heavy gauge, 3/16" steel receivers for long operating life. In addition, 3450 RPM motors assure maximum efficiency while maintaining minimum motor horsepower. Available in a wide range of sizes, these U.S. made pumps have just the right accessories and options to meet your unique needs. What's more, a nationwide network of stocking distributors means fast, easy, year-round access to pumps and replacement parts.

Features

- Heavy gauge steel receivers
- Simplex or duplex construction
- Bronze fitted centrifugal pumps
- Energy efficient 3450 RPM motors
- Automatic venting
- "Sterl-Seal" ceramic pump seal
- Heavy-duty make-up water valve
- Wide range of options and accessories



4100 SERIES



Built-In Features For Precise, Dependable Performance

- **Unit:** Completely factory assembled and tested. Simplex units have one receiver, one make-up water valve, and one vertical pump and motor assembly. Duplex units have 2 vertical pumps. All units are supplied with a gauge glass on the side of the receiver and a flat perforated brass strainer at the inlet to the pump.
- **Motors:** Heavy-duty, ballbearing, close-coupled pump motors with stainless steel shaft. 3450 RPM for greater efficiency and more economical operation.
- **Make-up Water Valve:** Mechanical, plug mounted valve with stainless steel float. Rated up to 45 PSI inlet water pressure.
- **Receiver:** Heavy gauge steel construction. All receivers of 45 gallon size and larger are supplied in duplex design, with one pump opening covered when a simplex design is specified.
- **Operation:** Boiler feed pump(s) are controlled by a water level controller mounted on the boiler. If condensate is lost or delayed in the system, it is automatically replaced in the receiver through the make-up water valve.
- **"SterlSeal" Pump Seal (A):** Features the ultimate in ceramic technology for exceptionally long life. Because the seal runs on the bronze impeller hub, the motor shaft is literally outside the pump. Consequently, the shaft is not exposed to corrosion by condensate. Rated for temperatures up to 250°F.
- **Isolation Valve (B):** Optional on 4100 Series Boiler Feed Pumps



A



B

Special Options

- Isolation valves
- Electric alternator for duplex units
- Thermometer
- Solenoid operated make-up water valve with reverse acting float switch
- Special motor construction, such as totally enclosed and explosion proof, is available
- Magnetic starters with H-O-A selector switches
- 1750 RPM motors, larger pumping capacities and higher discharge pressures - consult factory
- Custom sized tanks available
- Complete NEMA 12 Control Panel



Complete NEMA 12 Control Panel (Optional)

Motor Circuit Protector, HOA Selector Switch, External Reset, Control Circuit Transformer, Pilot Light (pump running), Removable Mounting Plate and Terminal Strip in a Single NEMA 12 Enclosure, Mounted and Wired, with Single Point Power Connection.

4100 SERIES

4100 Series Engineering and Capacity Data

Boiler HP	Discharge Pressure PSI	Pump Capacity, GPM	Motor HP	Rec. Cap., gallons	Unit Model Number		Shipping Weight, lbs	
					Simplex	Duplex	Simplex	Duplex
15	20	3	1/3	30	4122-GF	4122-GDF	200	240
	30		1/2		4132-JF	4132-JDF	260	300
	40		1		4142-JF	4142-JDF	265	310
	50		2		4152-JF	4152-JDF	275	330
30	20	6	1/3	30	4124-GF	4124-GDF	200	240
	30		1/2		4134-JF	4134-JDF	260	300
	40		1		4144-JF	4144-JDF	265	310
	50		2		4154-JF	4154-JDF	275	330
45	20	9	1/3	45	4126-GF	4126-GDF	240	280
	30		1/2		4136-JF	4136-JDF	300	340
	40		1		4146-JF	4146-JDF	305	350
	50		2		4156-JF	4156-JDF	315	370
60	20	12	1/3	60	4128-GF	4128-GDF	275	335
	30		1/2		4138-JF	4138-JDF	335	395
	40		1		4148-JF	4148-JDF	340	405
	50		2		4158-JF	4158-JDF	350	425
75	20	15	1/2	95	41210-GF	41210-GDF	360	420
	30		3/4		41310-JF	41310-JDF	420	480
	40		1		41410-JF	41410-JDF	425	490
	50		2		41510-JF	41510-JDF	435	510
100	20	20	1/2	95	41215-GF	41215-GDF	360	420
	30		1		41315-JF	41315-JDF	420	480
	40		1-1/2		41415-JF	41415-JDF	425	490
	50		2		41515-JF	41515-JDF	435	510
150	20	30	3/4	120	41220-GF	41220-GDF	415	475
	30		1		41320-JF	41320-JDF	475	535
	40		1-1/2		41420-JF	41420-JDF	480	545
	50		3		41520-JF	41520-JDF	490	565

Sample Specification

Furnish and install, where indicated on plans, a Sterling 4100 Series (simplex or duplex) boiler feed unit(s). Each pump shall deliver _____ GPM at a discharge pressure of _____ PSI. The unit shall be factory assembled and tested by the pump manufacturer and shall include a receiver, pump(s), make-up water valve, gauge glass, and accessories.

The receiver shall have a capacity of _____ gallons

and be of minimum 3/16" steel construction. Pump(s) shall be of the centrifugal type with two-piece enclosed brass impeller, cast iron housing, high temperature (250°F) mechanical seal and stainless steel motor shaft. The make-up water valve is to be a mechanical, plug-type with a stainless steel float. A flat perforated brass strainer shall be provided at the inlet to the pump from the tank. The motor(s) shall be vertical, 3450 RPM, _____ phase, _____ volt, 60 cycle, _____ H.P.

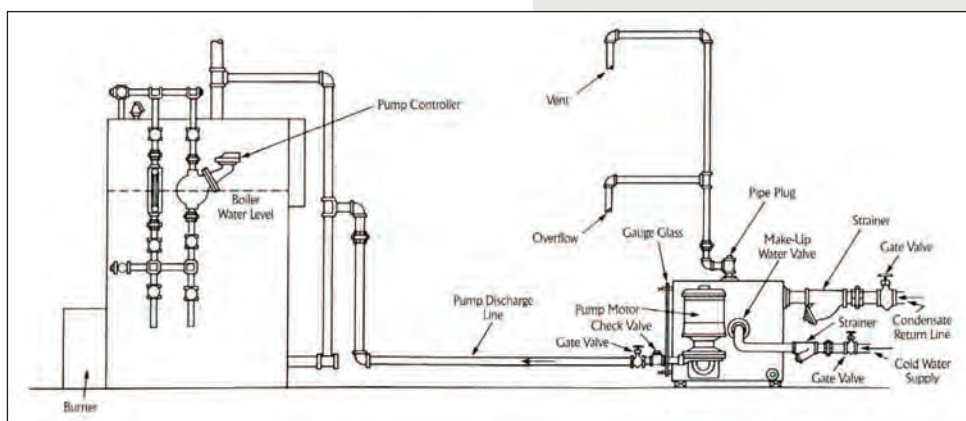

4100 SERIES



4100-GF Series

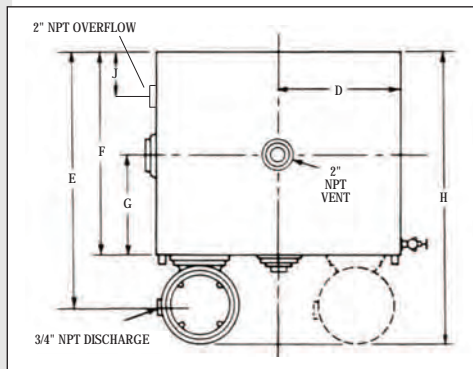
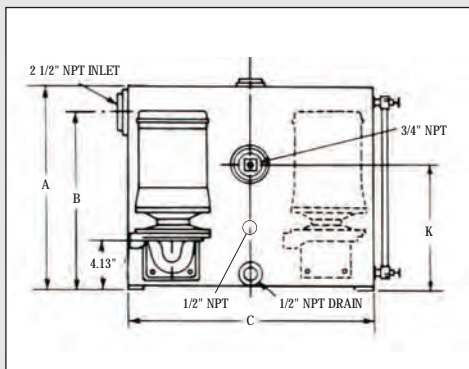

Receiver	A	B	C	D	E	F	G	H	J	K
30	18.38	16.12	22	11	23.5	18	9	28	4.5	10.88
45	26.38	24.12	22	11	23.5	18	9	28	4.5	10.88
60	28.38	26.12	28	14	23.5	18	9	28	4.5	10.88
95	28.38	26.12	28	14	33.5	28	14	38	4.5	10.88
120	36.38	33.75	28	14	33.5	28	14	38	6	12.00

4100-JF Series

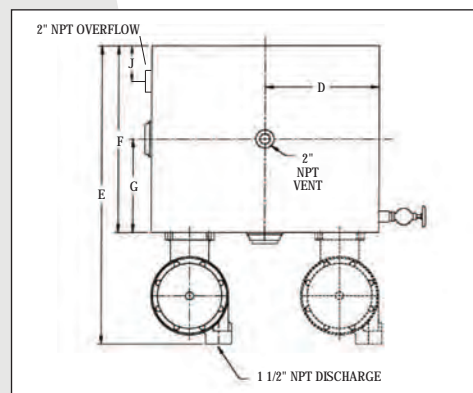
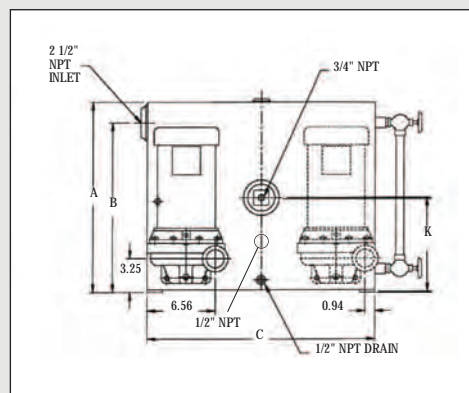

Receiver	A	B	C	D	E	F	G	J	K
30	18.38	16.12	22	11	29.31	18	9	4.5	10.88
45	26.38	24.12	22	11	29.31	18	9	4.5	10.88
60	28.38	26.12	28	14	29.31	18	9	4.5	10.88
95	28.38	26.12	28	14	39.31	28	14	4.5	10.88
120	36.38	33.75	28	14	39.31	28	14	6	12.00



STERLCO® PRODUCTS INCLUDE:

- HAND RADIATOR VALVES • THERMOSTATIC TRAPS • FLOAT AND THERMOSTATIC TRAPS
- INVERTED BUCKET TRAPS • CAST IRON STRAINERS • BRASS STRAINERS • BOILER FEED UNITS
- TANK AND PROCESS TEMPERATURE CONTROL VALVES • CONDENSATE PUMPS