

CLA-VAL

AUTOMATIC CONTROL VALVES

90-01KO/690-01KO

Place this manual with personal responsible
for maintenance of this valve

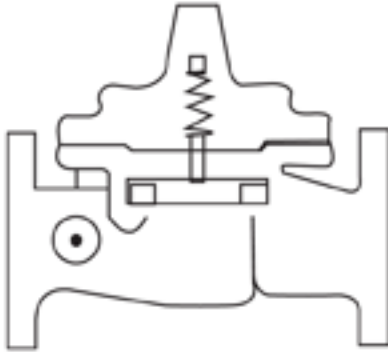

INSTALLATION

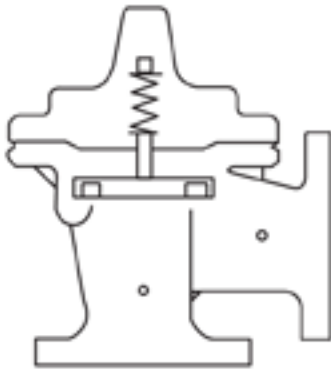

OPERATION

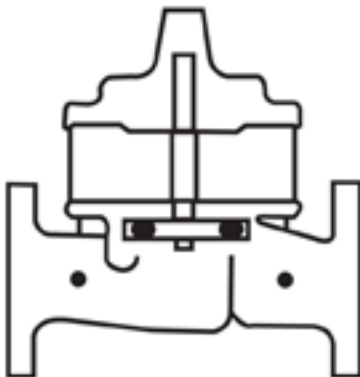

MAINTENANCE



CLA-VAL CO.

NEWPORT BEACH, CALIFORNIA

CATALOG NO.
90-01/690-01

DRAWING NO.
76551

REV.
L

TYPE OF VALVE AND MAIN FEATURES

PRESSURE REDUCING VALVE EQUIPPED
WITH CRD PRESSURE REDUCING CONTROL

DESIGN

DRAW	DP	11-30-78
CHK'D	CH	11-30-78
APVD	WAL	11-30-78

----- NOT FURNISHED BY CLA-VAL CO. ----- OPTIONAL FEATURES

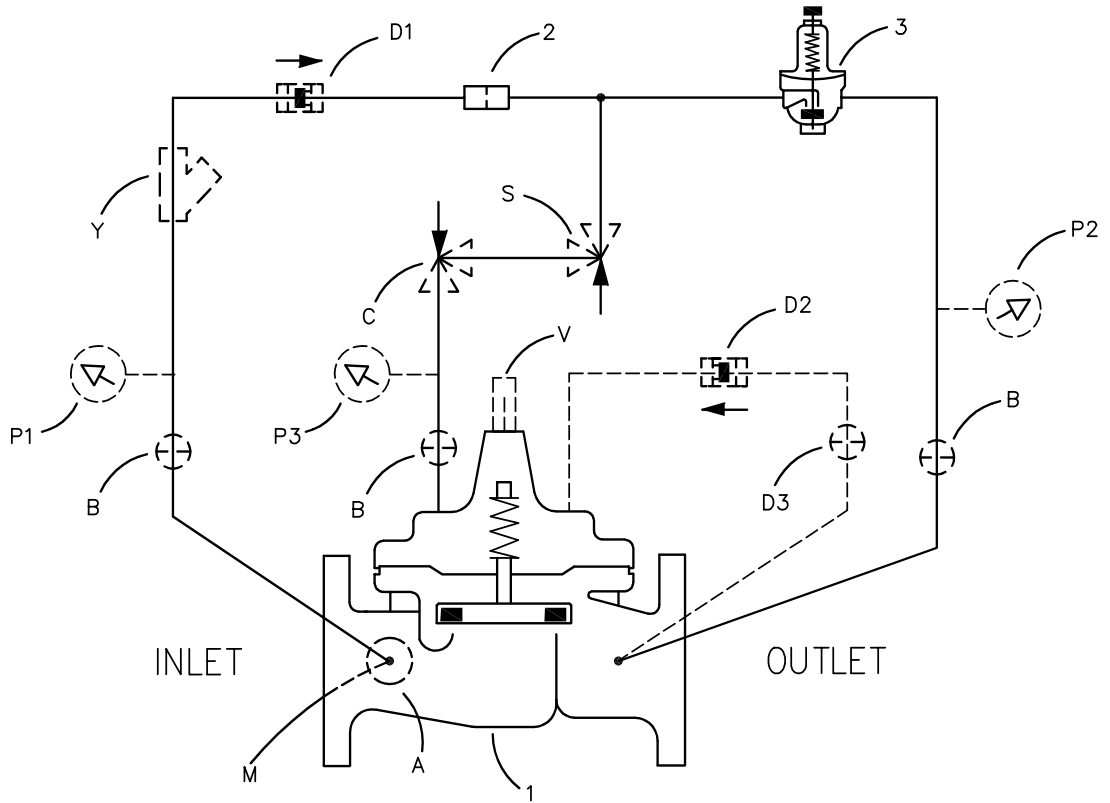

J	CAT NO. WAS 90-01; ADDED 100-20 (690-01) TO ITEM 1 (ECO 14478)	3-1-94
K	ADDED OPTIONAL FEATURES P & V (ECO 21821)	01-27-10
L	ADDED OPTIONAL FEATURE M (NED 75719)	09-01-11
EK		
AK		
AK		

CAD REVISION RECORD - DO NOT REVISE MANUALLY		DATE
BY		
TLC	7-1-91	
DESCRIPTION		
A-G	SEE REVISION FILE	
H	ADDED D OPTIONAL FEATURE & REVISED ON CAD (ECO 12041)	

ITEM NO.	BASIC COMPONENTS	QTY
1	100-01 HYTROL (90-01) MAIN VALVE 100-20 HYTROL (690-01) MAIN VALVE	1
2	X58C RESTRICTION FITTING	1
3	CRD PRESSURE REDUCING CONTROL	1

OPTIONAL FEATURE SUFFIX		ADDED TO CATALOG NUMBER	
A	X46A FLOW CLEAN STRAINER	1	
B	CK2 COCK (ISOLATION VALVE)	3	
C	CV FLOW CONTROL (CLOSING)	1	
D	CHECK VALVES WITH COCK	1	
M	X144 E-FLOW METER	1	
P	X141 PRESSURE GAUGE	3	
S	CV FLOW CONTROL (OPENING)		1
V	X101 VALVE POSITION INDICATOR		1
Y	X43 "Y" STRAINER		1

"THIS DRAWING IS THE PROPERTY OF CLA-VAL CO. AND SAME AND COPIES MADE THEREOF, IF ANY, SHALL BE RETURNED TO IT UPON DEMAND. DELIVERY AND DISCLOSURE HEREOF ARE SOLELY UPON CONDITION THAT THE SAME SHALL NOT BE USED, COPIED OR REPRODUCED, NOR SHALL THE SUBJECT HEREOF BE DISCLOSED IN ANY MANNER TO ANYONE FOR ANY PURPOSE, EXCEPT AS HEREIN AUTHORIZED, WITHOUT PRIOR WRITTEN APPROVAL OF CLA-VAL CO. THIS DRAWING IS SUBMITTED CONFIDENTIALLY AND MAY NOT BE USED IN THE MANUFACTURE OF ANY MATERIAL OR PRODUCT OTHER THAN SUCH MATERIALS AND PRODUCTS FURNISHED TO CLA-VAL CO. WHETHER OR NOT THE EQUIPMENT OR INFORMATION SHOWN HEREON IS PATENTED OR OTHERWISE PROTECTED, FULL TITLE AND COPYRIGHTS, IF ANY, IN AND TO THIS DRAWING AND/OR INFORMATION DELIVERED OR SUBMITTED ARE FULLY RESERVED CLA-VAL CO."



CLA-VAL CO.

NEWPORT BEACH, CALIFORNIA

CATALOG NO.

90-01/690-01

DRAWING NO.

76551

REV.

L

TYPE OF VALVE AND MAIN FEATURES

PRESSURE REDUCING VALVE EQUIPPED
WITH CRD PRESSURE REDUCING CONTROL

DESIGN

DRAW	DP	11-30-78
CHK'D	CH	11-30-78
APVD	WAL	11-30-78

OPERATING DATA

I. PRESSURE REDUCING FEATURE:

PRESSURE REDUCING CONTROL (3) IS A NORMALLY OPEN CONTROL THAT SENSES MAIN VALVE OUTLET PRESSURE CHANGES. AN INCREASE IN OUTLET PRESSURE TENDS TO CLOSE CONTROL (3) AND A DECREASE IN OUTLET PRESSURE TENDS TO OPEN CONTROL (3). THIS CAUSES MAIN VALVE COVER PRESSURE TO VARY AND THE MAIN VALVE MODULATES (OPENS AND CLOSES) MAINTAINING A RELATIVELY CONSTANT OUTLET PRESSURE. PRESSURE REDUCING CONTROL (3) ADJUSTMENT: TURN THE ADJUSTING SCREW CLOCKWISE TO INCREASE THE SETTING.

II. OPTIONAL FEATURE OPERATING DATA:

SUFFIX A (FLOW CLEAN STRAINER)

A SELF-CLEANING STRAINER IS INSTALLED IN THE MAIN VALVE INLET BODY BOSS WHICH PROTECTS THE PILOT SYSTEM FROM FOREIGN PARTICLES.

SUFFIX B (ISOLATION VALVES)

CK2 COCKS (B) ARE USED TO ISOLATE THE PILOT SYSTEM FROM MAIN LINE PRESSURE. THESE VALVES MUST BE OPEN DURING NORMAL OPERATION.

SUFFIX C (CLOSING SPEED CONTROL)

FLOW CONTROL (C) CONTROLS THE CLOSING SPEED OF THE MAIN VALVE. TURN THE ADJUSTING STEM CLOCKWISE TO MAKE THE MAIN VALVE CLOSE SLOWER.

SUFFIX D (CHECK VALVES WITH COCK):

WHEN OUTLET PRESSURE IS HIGHER THAN INLET PRESSURE, CHECK VALVE (D2) OPENS AND (D1) CLOSES. THIS DIRECTS THE HIGHER OUTLET PRESSURE INTO THE MAIN VALVE COVER AND THE MAIN VALVE CLOSES.

SUFFIX M (E-FLOW METER):

E-FLOW METER (M) PROVIDES ACCURATE FLOW MEASUREMENT DATA WITHOUT THE NEED OF A SEPARATE FLOW METER.

SUFFIX P (PRESSURE GAUGE):

PRESSURE GAUGES (P) PROVIDE PRESSURE READING IN THE INLET, OUTLET AND COVER CONNECTIONS.

SUFFIX S (OPENING SPEED CONTROL)

FLOW CONTROL (S) CONTROLS THE OPENING SPEED OF THE MAIN VALVE. TURN THE ADJUSTING STEM CLOCKWISE TO MAKE THE MAIN VALVE OPEN SLOWER.

CAD REVISION RECORD - DO NOT REVISE MANUALLY

DATE

BY

DESCRIPTION

SEE SHEET 1

LTR



CLA-VAL CO.

NEWPORT BEACH, CALIFORNIA

CATALOG NO.

90-01/690-01

DRAWING NO.

76551

REV.

L

TYPE OF VALVE AND MAIN FEATURES

PRESSURE REDUCING VALVE EQUIPPED
 WITH CRD PRESSURE REDUCING CONTROL

DESIGN

DRAW

DP

11-30-78

CHK'D

CH

11-30-78

APVD

WAL

11-30-78

OPERATING DATA-CONTINUED

SUFFIX V (VALVE POSITION INDICATOR):

VALVE POSITION INDICATOR (V) DISPLAYS A VISUAL POSITION OF THE MAIN VALVE STEM.

SUFFIX Y (Y-STRAINER)

A Y-PATTERN STRAINER IS INSTALLED IN THE PILOT SUPPLY LINE TO PROTECT THE PILOT SYSTEM FROM FOREIGN PARTICLES. THE STRAINER SCREEN MUST BE CLEANED PERIODICALLY.

III. CHECK LIST FOR PROPER OPERATION:

- () SYSTEM VALVES OPEN UPSTREAM AND DOWNSTREAM.
- () AIR REMOVED FROM THE MAIN VALVE COVER AND PILOT SYSTEM AT ALL HIGH POINTS.
- () CK2 COCKS (B) OPEN (OPTIONAL FEATURE).
- () PERIODIC CLEANING OF STRAINER (Y) IS RECOMMENDED (OPTIONAL FEATURE).
- () CV FLOW (C) AND (S) OPEN AT LEAST 4 TURNS (OPTIONAL FEATURE).

CAD REVISION RECORD - DO NOT REVISE MANUALLY

DATE

BY

DESCRIPTION

LTR

SEE SHEET 1



— MODEL — **90-01KO**
(Full Internal Port)

Anti-Cavitation Pressure Reducing Valve



- Virtually Cavitation Free Operation
- Sensitive and Accurate Pressure Control
- Easy Adjustment and Maintenance
- Tamper Resistant
- Optional Check Feature
- Fully Supported Frictionless Diaphragm

The Cla-Val Model 90-01KO Anti-Cavitation Hytrol Pressure Reducing Valve automatically reduces a higher inlet pressure to a steady lower downstream pressure, regardless of changing flow rate and/or varying inlet pressure. This valve is an accurate, pilot-operated regulator capable of holding downstream pressure to a pre-determined limit. When downstream pressure exceeds the pressure setting of the control pilot, the main valve and pilot valve close drip-tight.

If a check feature is added, and a pressure reversal occurs, the downstream pressure is admitted in the main valve cover chamber, closing the valve to prevent return flow.

Schematic Diagram

Item	Description
1	Hytrol (100-01KO Main Valve)
2	X58 Restriction Fitting
3	CRD Pressure Reducing Control

Optional Features

Item	Description
A	X46A Flow Clean Strainer
B	CK2 (Isolation Valve)
C	CV Flow Control (Closing)*
D	Check Valves with Isolation Valve
P	X141 Pressure Gauge
S	CV Speed Control (Opening)
V	X101 Valve Position Indicator
Y	X43 "Y" Strainer

*The closing speed control (optional) on this valve should always be open at least three (3) turns off its seat.

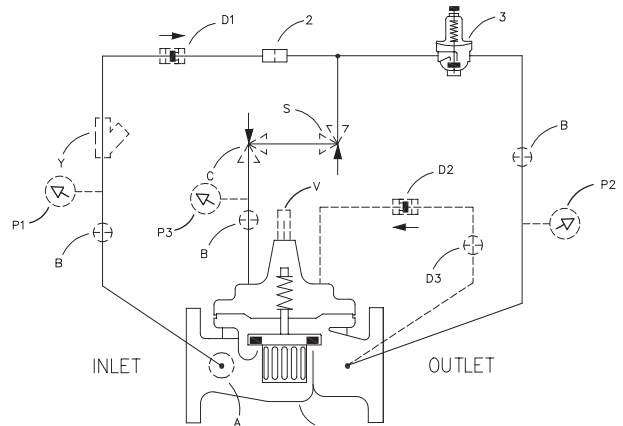

The "D" check feature on a vertically installed 6" and larger valves must be horizontally installed.

Typical Applications

Typical applications include pressure reducing valve station using Model 90-01BYKO and Model 90-01ASKO in parallel to handle wide range of flow rates. Larger Model 90-01BYKO valve meets requirements of peak loads and smaller Model 90-01ASKO handles low flows.

Cla-Val Model 90-01KO Pressure Reducing Valve with Anti-Cavitation Trim provides for optimum downstream pressure control while reducing noise and eliminating damage associated with cavitation.

See Cavitation Guide to determine if the valve is a candidate for the KO Anti-Cavitation Trim.

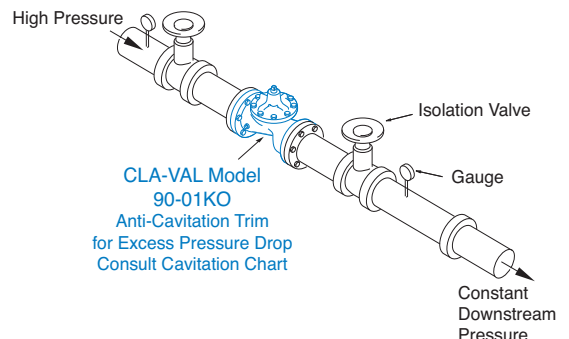
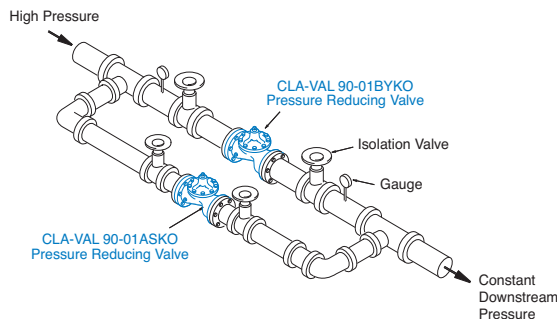

Specifications

Pattern	Globe	Angle	Grooved End
Size	1 1/4" - 36"	1 1/4" - 16" & 24"	1 1/4" - 8"

Operating Temp. Range

Fluids
-40° to 180° F



APPROVED
(4" - 24")

Model 100-01KO

Pressure Ratings (Recommended Maximum Pressure - psi)

Valve Body & Cover		Pressure Class				
		Flanged		Grooved	Threaded	
Grade	Material	ANSI Standards*	150 Class	300 Class	300 Class	End‡ Details
ASTM A536	Ductile Iron	B16.42	250	400	400	400
ASTM A216-WCB	Cast Steel	B16.5	285	400	400	400
ASTM B62	Bronze	B16.24	225	400	400	400

Note: * ANSI standards are for flange dimensions only.
 Flanged valves are available faced but not drilled.
 ‡ End Details machined to ANSI B2.1 specifications.
Valves for higher pressure are available; consult factory for details

Materials

Component	Standard Material Combinations		
Body & Cover	Ductile Iron	Cast Steel	Bronze
100-01KO Available Sizes	1 1/4" - 36"	3" - 16"	3" - 16"
Disc Retainer & Diaphragm Washer	Cast Iron	Cast Steel	Bronze
Trim: Disc Guide, Seat & Cover Bearing	Bronze is Standard Stainless Steel is Optional		
Disc	Buna-N® Rubber		
Diaphragm	Nylon Reinforced Buna-N® Rubber		
Stem, Nut & Spring	Stainless Steel		

For material options not listed, consult factory.
 Cla-Val manufactures valves in more than 50 different alloys.

100G-01KO ANTI-CAVITATION VALVE CURVES

SOLID LINE IS FULL OPEN FLOW CURVES FOR 18 FT/SEC CONTINUOUS DUTY APPLICATIONS
 DASHED LINE IS FULL OPEN FLOW CURVE FOR 25 FT/SEC INTERMITTENT DUTY APPLICATIONS

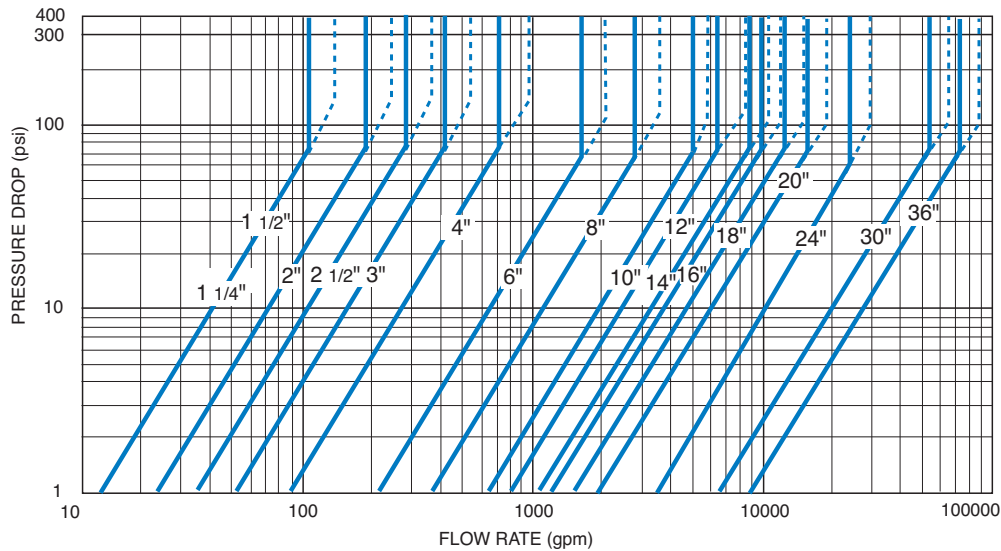

Notes: On Operating Differential

1. For atmospheric discharge, the maximum inlet pressure cannot exceed 150 psi.
2. For pressure differentials greater than 300 psi, the maximum flow velocity should not exceed 18 ft/sec.
3. Flow velocities greater than 25 ft/sec are not recommended.
4. Recommended minimum flow velocity is 1 ft/sec.
5. Consult factory for conditions exceeding these recommendations.

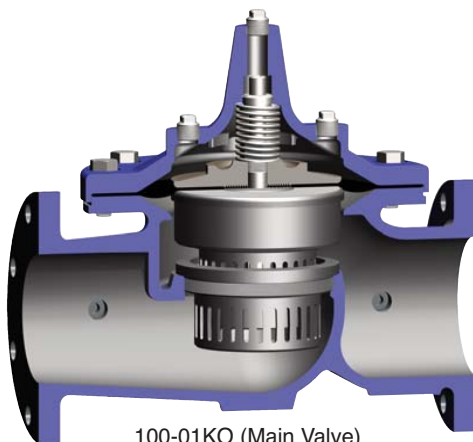

SELECTION GUIDELINE FOR KO ANTI-CAVITATION VALVES

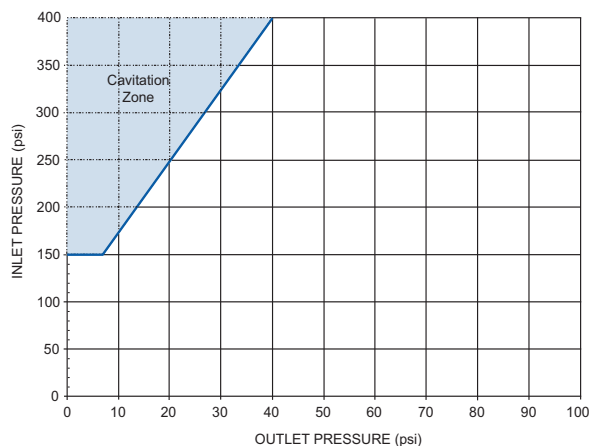

Model 100-01KO Dimensions (Full Internal Port) (In Inches)

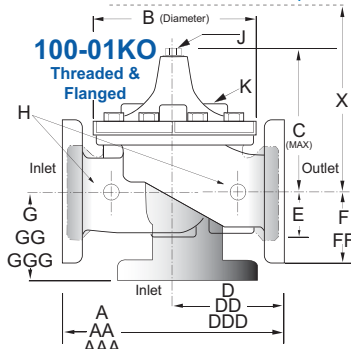

Note:
Consult Factory on 10", 12",
16" angle pattern

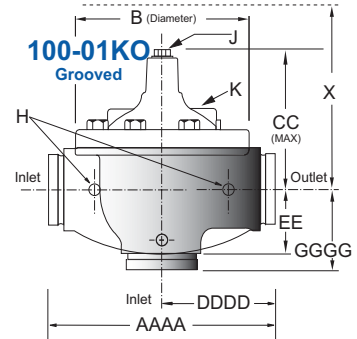
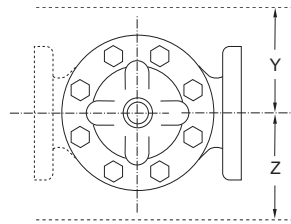

Valve Size (Inches)	1 1/4	1 1/2	2	2 1/2	3	4	6	8	10	12	14	16	18	20	24	30	36
A Threaded	7.25	7.25	9.38	11.00	12.50	—	—	—	—	—	—	—	—	—	—	—	—
AA 150 ANSI	—	8.50	9.38	11.00	12.00	15.00	20.00	25.38	29.75	34.00	39.00	41.38	46.00	52.00	61.50	63.00	76.00
AAA 300 ANSI	—	9.00	10.00	11.62	13.25	15.62	21.00	26.38	31.12	35.50	40.50	43.50	47.64	53.62	63.24	64.50	76.00
AAAA Grooved End	—	8.50	9.00	11.00	12.50	15.00	20.00	25.38	—	—	—	—	—	—	—	—	—
B Dia.	5.62	5.62	6.62	8.00	9.12	11.50	15.75	20.00	23.62	28.00	32.75	35.50	41.50	45.00	53.16	56.00	66.00
C Max.	5.50	5.50	6.50	7.56	8.19	10.62	13.38	16.00	17.12	20.88	24.19	25.00	39.06	41.90	43.93	54.60	61.50
CC Max. Grooved End	—	4.75	5.75	6.88	7.25	9.31	12.12	14.62	—	—	—	—	—	—	—	—	—
D Threaded	3.25	3.25	4.75	5.50	6.25	—	—	—	—	—	—	—	—	—	—	—	—
DD 150 ANSI	—	4.00	4.75	5.50	6.00	7.50	10.00	12.69	14.88	17.00	19.50	20.81	—	—	30.75	—	—
DDD 300 ANSI	—	4.25	5.00	5.88	6.38	7.88	10.50	13.25	15.56	17.75	20.25	21.62	—	—	31.62	—	—
DDDD Grooved End	—	—	4.75	—	6.00	7.50	—	—	—	—	—	—	—	—	—	—	—
E	1.12	1.12	1.50	1.69	2.06	3.19	4.31	5.31	9.25	10.75	12.62	15.50	12.95	15.00	17.75	21.31	24.56
EE Grooved End	—	2.00	2.50	2.88	3.12	4.25	6.00	7.56	—	—	—	—	—	—	—	—	—
F 150 ANSI	—	2.50	3.00	3.50	3.75	4.50	5.50	6.75	8.00	9.50	10.50	11.75	15.00	16.50	19.25	22.50	25.60
FF 300 ANSI	—	3.06	3.25	3.75	4.13	5.00	6.25	7.50	8.75	10.25	11.50	12.75	15.00	16.50	19.25	24.00	25.60
G Threaded	1.88	1.88	3.25	4.00	4.50	—	—	—	—	—	—	—	—	—	—	—	—
GG 150 ANSI	—	4.00	3.25	4.00	4.00	5.00	6.00	8.00	8.62	13.75	14.88	15.69	—	—	22.06	—	—
GGG 300 ANSI	—	4.25	3.50	4.31	4.38	5.31	6.50	8.50	9.31	14.50	15.62	16.50	—	—	22.90	—	—
GGGG Grooved End	—	—	3.25	—	4.25	5.00	—	—	—	—	—	—	—	—	—	—	—
H NPT Body Tapping	.375	.375	.375	.50	.50	.75	.75	1	1	1	1	1	1	1	1	2	2
J NPT Cover Center Plug	.25	.25	.50	.50	.50	.75	.75	1	1	1.25	1.5	2	1.5	1.5	1.5	2	2
K NPT Cover Tapping	.375	.375	.375	.50	.50	.75	.75	1	1	1	1	1	1	1	1	2	2
Stem Travel	0.4	0.4	0.6	0.7	0.8	1.1	1.7	2.3	2.8	3.4	4.0	4.5	5.1	5.63	6.75	7.5	8.5
Approx. Ship Wt. Lbs.	15	15	35	50	70	140	285	500	780	1165	1600	2265	2982	3900	6200	7703	11720
X Pilot System	11	11	13	14	15	17	29	31	33	36	40	40	43	47	68	79	85
Y Pilot System	9	9	9	10	11	12	20	22	24	26	29	30	32	34	39	40	45
Z Pilot System	9	9	9	10	11	12	20	22	24	26	29	30	32	34	39	42	47

Valve Size (mm)	32	40	50	65	80	100	150	200	250	300	350	400	450	500	600	750	900
A Threaded	184	184	238	279	318	—	—	—	—	—	—	—	—	—	—	—	—
AA 150 ANSI	—	216	238	279	305	381	508	645	756	864	991	1051	1168	1321	1562	1600	1930
AAA 300 ANSI	—	229	254	295	337	397	533	670	790	902	1029	1105	1210	1362	1606	1638	1930
AAAA Grooved End	—	216	228	279	318	381	508	645	—	—	—	—	—	—	—	—	—
B Dia.	143	143	168	203	232	292	400	508	600	711	832	902	1054	1143	1350	1422	1676
C Max.	140	140	165	192	208	270	340	406	435	530	614	635	992	1064	1116	1387	1562
CC Max. Grooved End	120	120	146	175	184	236	308	371	—	—	—	—	—	—	—	—	—
D Threaded	83	83	121	140	159	—	—	—	—	—	—	—	—	—	—	—	—
DD 150 ANSI	—	102	121	140	152	191	254	322	378	432	495	528	—	—	781	—	—
DDD 300 ANSI	—	108	127	149	162	200	267	337	395	451	514	549	—	—	803	—	—
DDDD Grooved End	—	—	121	—	152	191	—	—	—	—	—	—	—	—	—	—	—
E	29	29	38	43	52	81	110	135	235	273	321	394	329	381	451	541	624
EE Grooved End	—	52	64	73	79	108	152	192	—	—	—	—	—	—	—	—	—
F 150 ANSI	—	64	76	89	95	114	140	171	203	241	267	298	381	419	489	572	650
FF 300 ANSI	—	78	83	95	105	127	159	191	222	260	292	324	381	419	489	610	650
G Threaded	48	48	83	102	114	—	—	—	—	—	—	—	—	—	—	—	—
GG 150 ANSI	—	102	83	102	102	127	152	203	219	349	378	399	—	—	560	—	—
GGG 300 ANSI	—	102	89	110	111	135	165	216	236	368	397	419	—	—	582	—	—
GGGG Grooved End	—	—	83	—	108	127	—	—	—	—	—	—	—	—	—	—	—
H NPT Body Tapping	.375	.375	.375	.50	.50	.75	.75	1	1	1	1	1	1	1	1	2	2
J NPT Cover Center Plug	.25	.25	.50	.50	.50	.75	.75	1	1	1.25	1.5	2	1.5	1.5	1.5	2	2
K NPT Cover Tapping	.375	.375	.375	.50	.50	.75	.75	1	1	1	1	1	1	1	1	2	2
Stem Travel	10-32	10-32	10-32	10-32	1/8-28	1/8-28	3/8-24	3/8-24	3/8-24	3/8-24	3/8-24	3/8-24	1/2-20	3/4-16	3/4-16	3/4-16	3/4-16
Approx. Ship Wt. Kgs.	10	10	15	18	20	28	43	58	71	86	102	114	130	143	171	190	216
X Pilot System	7	7	16	23	32	64	129	227	354	528	726	1027	1353	1769	2812	3494	5316
Y Pilot System	9	9	9	10	11	12	20	22	24	26	29	30	32	34	39	40	45
Z Pilot System	9	9	9	10	11	12	20	22	24	26	29	30	32	34	39	42	47

Cla-Val Control Valves with KO ANTI-CAVITATION Trim operate with maximum efficiency when mounted in horizontal piping with the main valve cover Up. We recommend isolation valves be installed on inlet and outlet for maintenance. Adequate space above and around the valve for service personnel should be considered essential. A regular maintenance program should be established based on the specific application data. However, we recommend a thorough inspection be done at least once a year. Consult factory for specific recommendations.

90-01KO Valve Selection	100-01KO Pattern: Globe (G), Angle (A), End Connections: Threaded (T), Grooved (GR), Flanged (F) Indicate Available Sizes																	
	Inches	1¼	1½	2	2½	3	4	6	8	10	12	14	16	18	20	24	30	36
	mm	32	40	50	65	80	100	150	200	250	300	350	400	450	500	600	750	900
Basic Valve 100-01KO	Pattern	G, A	G, A	G, A	G, A	G, A	G, A	G, A	G, A	G, A	G, A	G, A	G, A	G	G	G, A	G	G
	End Detail	T	T, F, Gr*	T, F, Gr	T, F, Gr*	T, F, Gr	F, Gr	F, Gr*	F, Gr*	F	F	F	F	F	F	F	F	F
Suggested Flow (gpm)	Max. Continuous	84	115	190	270	410	710	1620	2810	4420	6280	7590	9920	12550	14900	22600	37700	52450
	Max. Intermittent	120	160	260	370	580	990	2250	3900	6150	8720	10540	13700	17500	21700	31300	48000	62500
	Min. Continuous	10	10	15	20	30	50	115	200	300	400	500	650	560	1073	1577	2650	3150
Suggested Flow (Liters/Sec)	Max. Continuous	5.3	7.3	12	17	26	45	102	177	279	397	479	694	792	940	1427	2379	3309
	Max. Intermittent	7.6	10	16	23	37	62	142	246	387	549	664	863	1104	1369	1972	3028	3940
	Min. Continuous	.6	.6	.9	1.3	1.9	3.2	7.2	13	19	25	32	41	41	57	110	132	180

100-01KO Series is the full internal port Hytrol.

For Lower Flows Consult Factory

*Globe Grooved Only

Functional Data

Valve Size		Inches	1¼	1½	2	2½	3	4	6	8	10	12	14	16	18	20	24	30	36
		mm.	32	40	50	65	80	100	150	200	250	300	350	400	450	500	600	750	900
C _v Factor	Globe Pattern	Gal./Min. (gpm.)	14	14	25	37	52	90	218	362	660	810	1100	1200	1550	1950	3900	6100	9150
		Litres/Sec. (l/s.)	3.4	3.4	6.0	8.9	12.5	21.6	52	87	159	194	264	288	360	469	938	1466	2199
	Angle Pattern	Gal./Min. (gpm.)	15	15	26	39	55	95	232	388	479	790	1075	1175	—	—	—	—	—
		Litres/Sec. (l/s.)	3.6	3.6	6.2	9.4	13.2	22.8	56	93	115	190	258	282	—	—	—	—	—
Equivalent Length of Pipe	Globe Pattern	Feet (ft.)	196	196	237	277	416	572	858	1315	2444	2118	1937	3022	3537	4199	4532	3897	3954
		Meters (m.)	60	60	72	84	127	174	262	401	745	646	590	921	1078	1280	1381	1188	1205
	Angle Pattern	Feet (ft.)	171	171	219	250	372	514	757	1145	2133	2226	2021	3152	—	—	—	—	—
		Meters (m.)	52	52	67	76	113	157	231	349	650	678	616	961	—	—	—	—	—
K Factor	Globe Pattern	30.6	30.6	26.1	24.3	29.3	29.0	25.5	27.7	41.0	27.7	22.8	31.4	30.2	29.5	28.9	17.6	15.1	
	Angle Pattern	26.7	26.7	24.1	21.8	26.2	26.0	22.5	24.1	35.8	29.1	23.8	32.8	—	—	—	—	—	
Liquid Displaced from Cover Chamber When Valve Opens	U.S. Gal.	0.2	0.2	.03	.04	.08	.17	.53	1.26	2.5	4.0	6.5	9.6	11	12	29	65	90	
	Litres	0.8	0.8	.12	.16	.30	.64	2.0	4.8	9.5	15.1	25.6	36.2	41.6	45.4	110	246	340	

For assistance in selecting appropriate valve options or valves manufactured with special design requirements, please contact our Regional Sales Office or Factory.

C_v Factor

Formulas for computing C_v Factor, Flow (Q) and Pressure Drop (ΔP):

$$C_v = \frac{Q}{\sqrt{\Delta P}} \quad Q = C_v \sqrt{\Delta P} \quad \Delta P = \left(\frac{Q}{C_v} \right)^2$$

K Factor (Resistance Coefficient)

The Value of K is calculated from the formula: $K = \frac{894d^4}{C_v^2}$ (U.S. system units)

Equivalent Length of Pipe

Equivalent lengths of pipe (L) are determined from the formula: $L = \frac{Kd}{12f}$ (U.S. system units)

Fluid Velocity

Fluid velocity can be calculated from the following formula: $V = \frac{.4085 Q}{d^2}$ (U.S. system units)

Where:

C_v = U.S. (gpm) @ 1 psi differential at 60° F water or
= (l/s) @ 1 bar (14.5 PSIG) differential at 15° C water

d = inside pipe diameter of Schedule 40 Steel Pipe (inches)

f = friction factor for clean, new Schedule 40 pipe (dimensionless) (from Cameron Hydraulic Data, 18th Edition, P 3-119)

K = Resistance Coefficient (calculated)

L = Equivalent Length of Pipe (feet)

Q = Flow Rate in U.S. (gpm) or (l/s)

V = Fluid Velocity (feet per second) or (meters per second)

ΔP = Pressure Drop in (psi) or (bar)

Pilot System Specifications

Adjustment Ranges

- 2 to 30 psi
- 15 to 75 psi
- 20 to 105 psi
- 30 to 300 psi*

*Supplied unless otherwise specified
Other ranges available, please consult factory

Temperature Range

Water: to 180°F

Materials

Standard Pilot System Materials

- Pilot Control: Bronze ASTM B62
- Trim: Stainless Steel Type 303
- Rubber: Buna-N® Synthetic Rubber

Optional Pilot System Materials

Pilot Systems are available with optional Aluminum, Stainless Steel or Monel materials.

Note: Available with remote sensing control.

When Ordering, Please Specify

1. Catalog No. 90-01KO
2. Valve Size
3. Pattern - Globe or Angle
4. Pressure Class
5. Threaded, Flanged or Grooved End
6. Trim Material
7. Adjustment Range
8. Desired Options
9. When Vertically Installed



—MODEL— 100-01 Hytrol Valve

Description

The Cla-Val Model 100-01 Hytrol Valve is a main valve for Cla-Val Automatic Control Valves. It is a hydraulically operated, diaphragm-actuated, globe or angle pattern valve.

This valve consists of three major components; body, diaphragm assembly, and cover. The diaphragm assembly is the only moving part. The diaphragm assembly uses a diaphragm of nylon fabric bonded with synthetic rubber. A synthetic rubber disc, contained on three and one half sides by a disc retainer and disc guide, forms a seal with the valve seat when pressure is applied above the diaphragm. The diaphragm assembly forms a sealed chamber in the upper portion of the valve, separating operating pressure from line pressure.

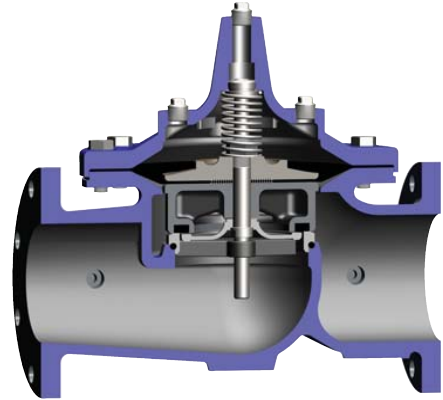

Installation

1. Before valve is installed, pipe lines should be flushed of all chips, scale and foreign matter.
2. It is recommended that either gate or block valves be installed on both ends of the 100-01 Hytrol Valve to facilitate isolating the valve for preventive maintenance and repairs.
3. Place the valve in the line with flow through the valve in the direction indicated on the inlet nameplate. (See "Flow Direction" Section)
4. Allow sufficient room around valve to make adjustments and for disassembly.
5. Cla-Val 100-01 Hytrol Valves operate with maximum efficiency when mounted in horizontal piping with the cover UP, however, other positions are acceptable. Due to size and weight of the cover and internal components of 8 inch and larger valves,

installation with the cover UP is advisable. This makes internal parts readily accessible for periodic inspection.

6. Caution must be taken in the installation of this valve to insure that galvanic and/or electrolytic action does not take place. The proper use of dielectric fittings and gaskets are required in all systems using dissimilar metals.

7. If a pilot control system is installed on the 100-01 Hytrol Valve, use care to prevent damage. If it is necessary to remove fittings or components, be sure they are kept clean and replaced exactly as they were.

8. After the valve is installed and the system is first pressurized, vent air from the cover chamber and pilot system tubing by loosening fittings at all high points.

Principles of Operation

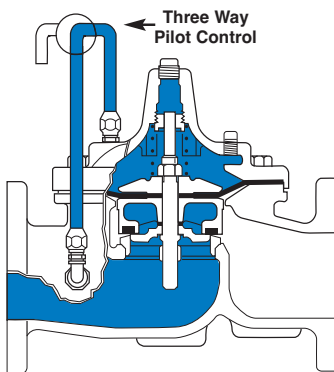

Tight Closing Operation

When pressure from the valve inlet (or an equivalent independent operating pressure) is applied to the diaphragm chamber the valve closes drip-tight.

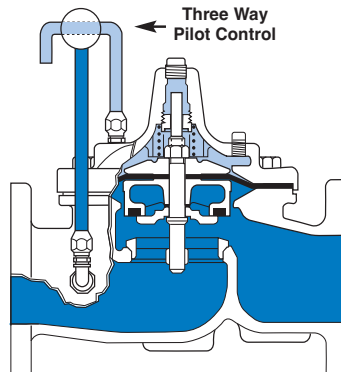

Full Open Operation

When pressure in diaphragm chamber is relieved to a zone of lower pressure (usually atmosphere) the line pressure (5 psi Min.) at the valve inlet opens the valve.

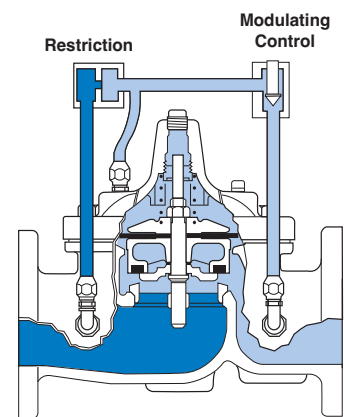

Modulating Action

Valve modulates when diaphragm pressure is held at an intermediate point between inlet and discharge pressure. With the use of a Cla-Val. "modulating control," which reacts to line pressure changes, the pressure above the diaphragm is varied, allowing the valve to throttle and compensate for the change.

Flow Direction

The flow through the 100-01 Hytrol Valve can be in one of two directions. When flow is “up-and-over the seat,” it is in “normal” flow and the valve will fail in the open position. When flow is “over-the seat-and down,” it is in “reverse” flow and the valve will fail in the closed position. There are no permanent flow arrow markings.



Recommended Tools

1. Three pressure gauges with ranges suitable to the installation to be put at Hytrol inlet, outlet and cover connections.
2. Cla-Val Model X101 Valve Position Indicator. This provides visual indication of valve position without disassembly of valve.
3. Other items are: suitable hand tools such as screwdrivers, wrenches, etc. soft jawed (brass or aluminum) vise, 400 grit wet or dry sandpaper and water for cleaning.

Troubleshooting

The following troubleshooting information deals strictly with the Model 100-01 Hytrol Valve. This assumes that all other components of the pilot control system have been checked out and are in proper working condition. (See appropriate sections in Technical Manual for complete valve).

All trouble shooting is possible without removing the valve from the line or removing the cover. It is highly recommended to permanently install a Model X101 Valve Position Indicator and three gauges in unused Hytrol inlet, outlet and cover connections.

SYMPTOM	PROBABLE CAUSE	REMEDY
Fails to Close	Closed isolation valves in control system, or in main line.	Open Isolation valves.
	Lack of cover chamber pressure.	Check upstream pressure, pilot system, strainer, tubing, valves, or needle valves for obstruction.
	Diaphragm damaged. (See Diaphragm Check.)	Replace diaphragm.
	Diaphragm assembly inoperative. Corrosion or excessive scale build up on valve stem. (See Freedom of Movement Check)	Clean and polish stem. Inspect and replace any damaged or badly eroded part.
	Mechanical obstruction. Object lodged in valve. (See Freedom of Movement Check)	Remove obstruction.
	Worn disc. (See Tight Sealing Check)	Replace disc.
	Badly scored seat. (See Tight Sealing Check)	Replace seat.
Fails to Open	Closed upstream and/or downstream isolation valves in main line.	Open isolation valves.
	Insufficient line pressure.	Check upstream pressure. (Minimum 5 psi flowing line pressure differential.)
	Diaphragm assembly inoperative. Corrosion or excessive buildup on valve stem. (See Freedom of Movement Check)	Clean and polish stem. Inspect and replace any damaged or badly eroded part.
	Diaphragm damaged. (For valves in "reverse flow" only)	Replace diaphragm.

After checking out probable causes and remedies, the following three checks can be used to diagnose the nature of the problem before maintenance is started. They must be done in the order shown.

Three Checks

The 100-01 Hytrol Valve has only one moving part (the diaphragm and disc assembly). So, there are only three major types of problems to be considered.

First: Valve is stuck - that is, the diaphragm assembly is not free to move through a full stroke either from open to close or vice versa.

Second: Valve is free to move and can't close because of a worn out diaphragm.

Third: Valve leaks even though it is free to move and the diaphragm isn't leaking.

CAUTION:

Care should be taken when doing the troubleshooting checks on the 100-01 Hytrol Valve. These checks do require the valve to open fully. This will either allow a high flow rate through the valve, or the downstream pressure will quickly increase to the inlet pressure. In some cases, this can be very harmful. Where this is the case, and there are no block valves in the system to protect the downstream piping, it should be realized that **the valve cannot be serviced under pressure.** Steps should be taken to remedy this situation before proceeding any further.

Diaphragm Check (#1)

1. Shut off pressure to the Hytrol Valve by slowly closing upstream and downstream isolation valves. **SEE CAUTION.**
2. Disconnect or close all pilot control lines to the valve cover and leave only one fitting in highest point of cover open to atmosphere.
3. With the cover vented to atmosphere, slowly open upstream isolation valve to allow some pressure into the Hytrol Valve body. Observe the open cover tapping for signs of continuous flow. It is not necessary to fully open isolating valve. Volume in cover chamber capacity chart will be displaced as valve moves to open position. Allow sufficient time for diaphragm assembly to shift position. If there is no continuous flow, you can be quite certain the diaphragm is sound and the diaphragm assembly is tight. If the fluid appears to flow continuously this is a good reason to believe the diaphragm is either damaged or it is loose on the stem. In either case, this is sufficient cause to remove the valve cover and investigate the leakage. (See "Maintenance" Section for procedure.)

COVER CHAMBER CAPACITY (Liquid Volume displaced when valve opens)

Valve size (inches)	Displacement	
	Gallons	Liters
1 1/4	.020	.07
1 1/2	.020	.07
2	.032	.12
2 1/2	.043	.16
3	.080	.30
4	.169	.64
6	.531	2.0
8	1.26	4.8
10	2.51	9.5
12	4.00	15.1
14	6.50	24.6
16	9.57	36.2
20	12.00	45.4
24	29.00	109.8
30	42.00	197.0
36	90.00	340.0

Freedom of Movement Check (#2)

4. Determining the Hytrol Valve's freedom of movement can be done by one of two methods.
5. For most valves it can be done after completing Diaphragm Check (Steps 1, 2, and 3). **SEE CAUTION.** At the end of step 3 the valve should be fully open.
6. If the valve has a Cla-Val X101 Position Indicator, observe the indicator to see that the valve opens wide. Mark the point of maximum opening.
7. Re-connect enough of the control system to permit the application of inlet pressure to the cover. Open pilot system cock so pressure flows from the inlet into the cover.
8. While pressure is building up in the cover, the valve should close smoothly. There is a hesitation in every Hytrol Valve closure, which can be mistaken for a mechanical bind. The stem will appear to stop moving very briefly before going to the closed position. This slight pause is caused by the diaphragm flexing at a particular point in the valve's travel and is not caused by a mechanical bind.
9. When closed, a mark should be made on the X101 Valve position indicator corresponding to the "closed" position. The distance between the two marks should be approximately the stem travel shown in chart.

STEM TRAVEL

(Fully Open to Fully Closed)

Valve Size (inches)		Travel (inches)	
Inches	MM	Inches	MM
1 1/4	32	0.4	10
1 1/2	40	0.4	10
2	50	0.6	15
2 1/2	65	0.7	18
3	80	0.8	20
4	100	1.1	28
6	150	1.7	43
8	200	2.3	58
10	250	2.8	71
12	300	3.4	86
14	350	4.0	100
16	400	4.5	114
20	500	5.6	143
24	600	6.7	165
30	800	7.5	190
36	900	8.5	216

10. If the stroke is different than that shown in stem travel chart this is a good reason to believe something is mechanically restricting the stroke of the valve at one end of its travel. If the flow does not stop through the valve when in the indicated "closed" position, the obstruction probably is between the disc and the seat. If the flow does stop, then the obstruction is more likely in the cover. In either case, the cover must be removed, and the obstruction located and removed. The stem should also be checked for scale build-up. (See "Maintenance, section for procedure.)

11. For valves 6" and smaller, the Hytrol Valve's freedom of movement check can also be done after all pressure is removed from the valve. **SEE CAUTION.** After closing inlet and outlet isolation valves and bleeding pressure from the valve, check that the cover chamber and the body are temporarily vented to atmosphere. Insert fabricated tool into threaded hole in top of valve stem, and lift the diaphragm assembly manually. Note any roughness. The diaphragm assembly should move smoothly throughout entire valve stroke. The tool is fabricated from rod that is threaded on one end to fit valve stem and has a "T" bar handle of some kind on the other end for easy gripping. (See chart in Step 4 of "Disassembly" Section.)

12. Place marks on this diaphragm assembly lifting tool when the valve is closed and when manually positioned open. The distance between the two marks should be approximately the stem travel shown in stem travel chart. If the stroke is different than that shown, there is a good reason to believe something is mechanically restricting the stroke of the valve. The cover must be removed, and the obstruction located and removed. The stem should also be checked for scale build-up. (See "Maintenance" Section for procedure.)

Tight Sealing Check (#3)

13. Test for seat leakage after completing checks #1 & #2 (Steps 1 to 12). **SEE CAUTION.** Close the isolation valve downstream of the Hytrol Valve. Apply inlet pressure to the cover of the valve, wait until it closes. Install a pressure gauge between the two closed valves using one of the two ports in the outlet side of the Hytrol. Watch the pressure gauge. If the pressure begins to climb, then either the downstream isolation valve is permitting pressure to creep back, or the Hytrol is allowing pressure to go through it. Usually the pressure at the Hytrol inlet will be higher than on the isolation valve discharge, so if the pressure goes up to the inlet pressure, you can be sure the Hytrol is leaking. Install another gauge downstream of isolating valve. If the pressure between the valves only goes up to the pressure on the isolation valve discharge, the Hytrol Valve is holding tight, and it was just the isolation valve leaking.

Maintenance

Preventative Maintenance

The Cla-Val Co. Model 100-01 Hytrol Valve requires no lubrication or packing and a minimum of maintenance. However, a periodic inspection schedule should be established to determine how the operating conditions of the system are affecting the valve. The effect of these actions must be determined by inspection.

Disassembly

Inspection or maintenance can be accomplished without removing the valve from the line. Repair kits with new diaphragm and disc are recommended to be on hand before work begins.

WARNING: Maintenance personnel can be injured and equipment damaged if disassembly is attempted with pressure in the valve. **SEE CAUTION.**

1. Close upstream and downstream isolation valves **and independent operating pressure when used** to shut off all pressure to the valve.

2. Loosen tube fittings in the pilot system to remove pressure from valve body and cover chamber. After pressure has been released from the valve, use care to remove the controls and tubing. Note and sketch position of tubing and controls for re-assembly. The schematic in front of the Technical Manual can be used as a guide when reassembling pilot system.

3. Remove cover nuts and remove cover. If the valve has been in service for any length of time, chances are the cover will have to be loosened by driving upward along the edge of the cover with a **dull cold chisel**.

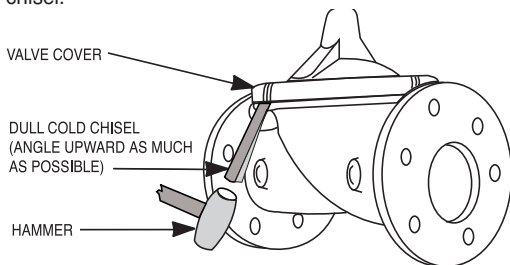

On 6" and smaller valves block and tackle or a power hoist can be used to lift valve cover by inserting proper size eye bolt in place of the center cover plug. on 8" and larger valves there are 4 holes (5/8" – 11 size) where jacking screws and/or eye bolts may be inserted for lifting purposes. **Pull cover straight up** to keep from damaging the integral seat bearing and stem.

COVER CENTER PLUG SIZE

Valve Size	Thread Size (NPT)
1 1/4" – 1 1/2"	1/4"
2" – 3"	1/2"
4" – 6"	3/4"
8" – 10"	1"
12"	1 1/4"
14"	1 1/2"
16"	2"
20" & 24"	2"
30" & 36"	2"

4. Remove the diaphragm and disc assembly from the valve body. With smaller valves this can be accomplished by hand by **pulling straight up on the stem so as not to damage the seat bearing**. On large valves, an eye bolt of proper size can be installed in the stem and the diaphragm assembly can be then lifted with a block and tackle or power hoist. Take care not to damage the stem or bearings. The valve won't work if these are damaged.

VALVE STEM THREAD SIZE

Valve Size	Thread Size (UNF Internal)
1 1/4" – 2 1/2"	10–32
3" – 4"	1/4–28
6" – 14"	3/8–24
16"	1/2–20
20	3/4-16
24"	3/4-16
30"	3/4-16
36"	3/4-16

5. The next item to remove is the stem nut. Examine the stem threads above the nut for signs of mineral deposits or corrosion. If the threads are not clean, use a wire brush to remove as much of the residue as possible. Attach a good fitting wrench to the nut and give it a sharp "rap" rather than a steady pull. Usually several blows are sufficient to loosen the nut for further removal. On the smaller valves, the entire diaphragm assembly can be held by the stem in a vise **equipped with soft brass jaws** before removing the stem nut.

The use of a pipe wrench or a vise without soft brass jaws scars the fine finish on the stem. No amount of careful dressing can restore the stem to its original condition. Damage to the finish of the stem can cause the stem to bind in the bearings and the valve will not open or close.

6. After the stem nut has been removed, the diaphragm assembly breaks down into its component parts. Removal of the disc from the disc retainer can be a problem if the valve has been in service for a long time. Using two screwdrivers inserted along the outside edge of the disc usually will accomplish its removal. Care should be taken to preserve the spacer washers in water, particularly if no new ones are available for re-assembly.

7. The only part left in the valve body is the seat which ordinarily does not require removal. Careful cleaning and polishing of inside and outside surfaces with 400 wet/dry sandpaper will usually restore the seat's sharp edge. If, however, it is badly worn and replacement is necessary, it can be easily removed.

Seats in valve sizes 1 1/4" through 6" are threaded into the valve body. They can be removed with accessory X109 Seat Removing Tool available from the factory. On 8" and larger valves, the seat is held in place by flat head machine screws. Use a tight-fitting, long shank screwdriver to prevent damage to seat screws. If upon removal of the screws the seat cannot be lifted out, it will be necessary to use a piece of angle or channel iron with a hole drilled in the center. Place it across the body so a long stud can be inserted through the center hole in the seat and the hole in the angle iron. By tightening the nut a uniform upward force is exerted on the seat for removal.

NOTE: Do not lift up on the end of the angle iron as this may force the integral bearing out of alignment, causing the stem to bind.

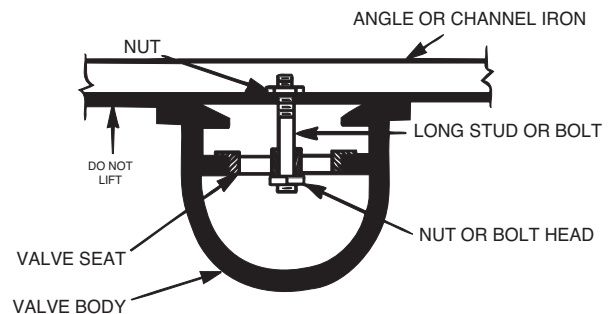

Lime Deposits

One of the easiest ways to remove lime deposits from the valve stem or other metal parts is to dip them in a 5-percent muriatic acid solution just long enough for the deposit to dissolve. This will remove most of the common types of deposits. **CAUTION: USE EXTREME CARE WHEN HANDLING ACID.** Rinse parts in water before handling. If the deposit is not removed by acid, then a fine grit (400) wet or dry sandpaper can be used with water.

Inspection of Parts

After the valve has been disassembled, each part should be examined carefully for signs of wear, corrosion, or any other abnormal condition. Usually, it is a good idea to replace the rubber parts (diaphragm and disc) unless they are free of signs of wear. These are available in a repair kit. Any other parts which appear doubtful should be replaced. **WHEN ORDERING PARTS, BE SURE TO GIVE COMPLETE NAMEPLATE DATA, ITEM NUMBER AND DESCRIPTION.**

NOTE: If a new disc isn't available, the existing disc can be turned over, exposing the unused surface for contact with the seat. The disc should be replaced as soon as practical.

Reassembly

1. Reassembly is the reverse of the disassembly procedure. If a new disc has been installed, it may require a different number of spacer washers to obtain the right amount of "grip" on the disc. When the diaphragm assembly has been tightened to a point where the diaphragm cannot be twisted, the disc should be compressed very slightly by the disc guide. Excessive compression should be avoided. Use just enough spacer washers to hold the disc firmly without noticeable compression.

2. **MAKE SURE THE STEM NUT IS VERY TIGHT.** Attach a good fitting wrench to the nut and give it a sharp "rap" rather than a steady pull. Usually several blows are sufficient to tighten the stem nut for final tightening. Failure to do so could allow the diaphragm to pull loose and tear when subjected to pressure.

3. Carefully install the diaphragm assembly by lowering the stem through the seat bearing. Take care not to damage the stem or bearing. Line up the diaphragm holes with the stud or bolt holes on the body. On larger valves with studs, it may be necessary to hold the diaphragm assembly up part way while putting the diaphragm over the studs.

4. Put spring in place and replace cover. Make sure diaphragm is lying smooth under the cover.

5. Tighten cover nuts firmly using a cross-over pattern until all nuts are tight.

6. Test Hytrol Valve before re-installing pilot valve system.

Test Procedure After Valve Assembly

There are a few simple tests which can be made in the field to make sure the Hytrol Valve has been assembled properly. Do these before installing pilot system and returning valve to service. These are similar to the three troubleshooting tests.

1. Check the diaphragm assembly for freedom of movement after all pressure is removed from the valve. **SEE CAUTION.** Insert fabricated tool into threaded hole in top of valve stem, and lift the diaphragm assembly manually. Note any roughness, sticking or grabbing. The diaphragm assembly should move smoothly throughout entire valve stroke. The tool is fabricated from rod that is threaded on one end to fit valve stem (See chart in Step 4 of "Disassembly" section.) and has a "T" Bar handle of some kind on the other end for easy gripping.

Place marks on this diaphragm assembly lifting tool when the valve is closed and when manually positioned open. The distance between the two marks should be approximately the stem travel shown in stem travel chart. (See "Freedom of Movement Check" section.) If the stroke is different than that shown, there is a good reason to believe something is mechanically restricting the stroke of the valve. The cover must be removed, the obstruction located and removed. (See "Maintenance" Section for procedure.)

Due to the weight of the diaphragm assembly this procedure is not possible on valves 8" and larger. On these valves, the same determination can be made by carefully introducing a low pressure-less than five psi) into the valve body with the cover vented. **SEE CAUTION.** Looking in cover center hole see the diaphragm assembly lift easily without hesitation, and then settle back easily when the pressure is removed.

2. To check the valve for drip-tight closure, a line should be connected from the inlet to the cover, and pressure applied at the inlet of the valve. If properly assembled, the valve should hold tight with as low as ten PSI at the inlet. See "Tight Sealing Check" section.)

3. With the line connected from the inlet to the cover, apply full working pressure to the inlet. Check all around the cover for any leaks. Re-tighten cover nuts if necessary to stop leaks past the diaphragm.

4. Remove pressure, then re-install the pilot system and tubing exactly as it was prior to removal. **Bleed air from all high points.**

5. Follow steps under "Start-Up and Adjustment" Section in Technical Manual for returning complete valve back to service.

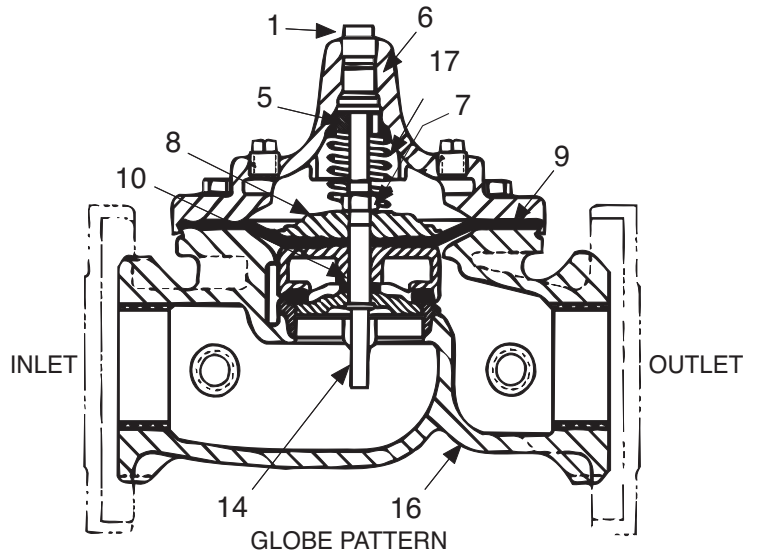
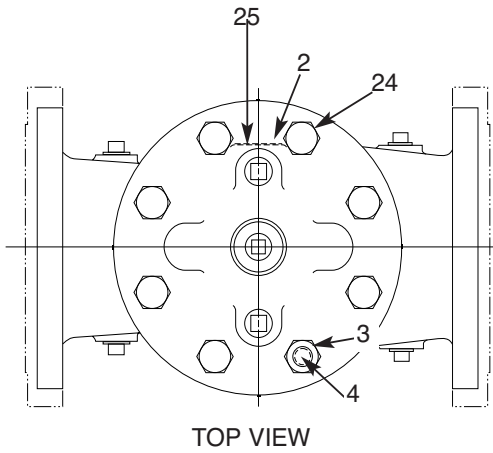

PARTS LIST

Item	Description
1.	Pipe Plug
2.	Drive Screws (for nameplate)
3.	Hex Nut (8" and larger)
4.	Stud (8" and larger)
5.	Cover Bearing
6.	Cover
7.	Stem Nut
8.	Diaphragm Washer
9.	Diaphragm
10.	Spacer Washers
11.	Disc Guide
12.	Disc Retainer
13.	Disc
14.	Stem
15.	Seat
16.	Body
17.	Spring
22.	Flat Head Screws (8" and larger)
23.	Seat O-Ring
24.	Hex head Bolt (1 1/4" thru 4")
25.	Nameplate
26.	Upper Spring Washer (Epoxy coated valves only)
27.	Lower Spring Washer (Epoxy coated valves only)
28.	Cover Bearing Housing (16" only)
29.	Cover O-Ring (16" only)
30.	Hex Bolt (16" only)
31.	Pipe Cap (16" only)

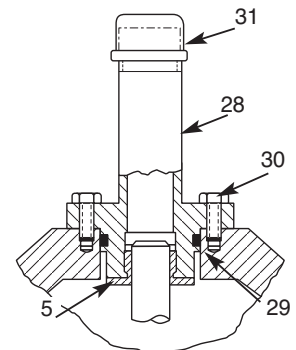
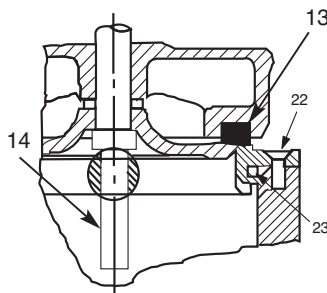
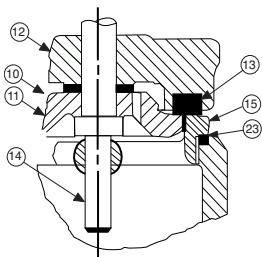
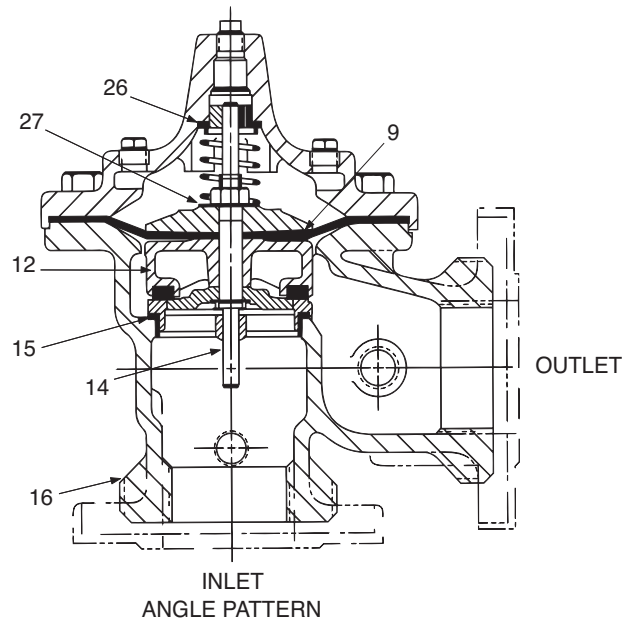



— MODEL — 100-01 Hytrol Valve Service Data

Description 100-01 Hytrol Valve

The Cla-Val Model 100-01 Hytrol Valve is a main valve for Cla-Val Automatic Control Valves. It is a hydraulically operated, diaphragm-actuated, globe or angle pattern valve.

This valve consists of three major components; body, diaphragm assembly, and cover. The diaphragm assembly is the only moving part. The diaphragm assembly uses a diaphragm of nylon fabric bonded with synthetic rubber. A synthetic rubber disc, contained on three and one half sides by a disc retainer and disc guide, forms a seal with the valve seat when pressure is applied above the diaphragm. The diaphragm assembly forms a sealed chamber in the upper portion of the valve, separating operating pressure from line pressure.

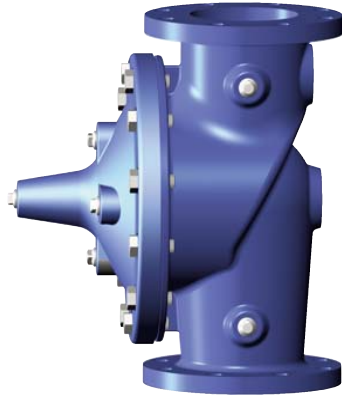

Description 100-20 600 Series Hytrol Valve

The Cla-Val Model 100-20 Hytrol Valve (600 Series main valve) have only one part -the body- that is different from standard 100 Series Cla-Val main valve parts. The remaining parts of the 600 series main valve are standard Cla-Val main valve parts. All service and maintenance information for the standard 100 Series main valves also apply to the 600 series main valves.

The most important thing to remember when ordering main valve repair kits and replacement parts, except for the body, all other parts are going to be for a smaller size main valve. Cla-Val identifies main valve parts with the flange size of the standard 100 Series main valve. Refer to the "Main Valve Sizes" chart below.

HYTROL Service Data

HYTROL SIZE		Stem Travel		Cover Capacity Displacement		Valve Stem Thread	Cover Center Plug	Cover Nut or Bolt			Cover Lifting Holes	Cover Plug		Cover Torque		Stem Nut**		Stem Nut Torque	
100-01	100-20	inches	mm	inches	mm	UNF-Internal	NPT	Thread (Bolt)	Socket	Qty	UNC	Thread	Socket	ft. Lbs.	in. Lbs.	Thread	Socket (Long)	Lubed	DRY
1"	25			0.3	8		1/4"	1/4" - 20 (B)	7/16"	8				4	48	3/8" - 24		4	6
1 1/4"	32			0.4	10	10 - 32	1/4"	5/16" - 18 (B)	1/2"	8				8	96	7/16" - 20		6	10
1 1/2"	40			0.4	10	10 - 32	1/4"	5/16" - 18 (B)	1/2"	8				8	96	7/16" - 20		6	10
2"	50			0.6	15	10 - 32	1/2"	3/8" - 16 (B)	9/16"	8		3/8"	7/16"	12	12	1/2" - 20	3/4"	10	15
2 1/2"	65			0.7	18	10 - 32	1/2"	7/16" - 14 (B)	5/8"	8		1/2"	9/16"	20	20	5/8" - 18	15/16"	21	30
3"	80	4"	100	0.8	20	1/4 - 28	1/2"	1/2" - 13 (B)	3/4"	8		1/2"	9/16"	30	30	5/8" - 18	15/16"	21	30
4"	100	6"	150	1.1	23	1/4 - 28	3/4"	3/4" - 10 (B)	1 1/8"	8		3/4"	5/8"	110	110	3/4" - 16	1 1/16"	40	60
6"	150	8"	200	1.7	43	3/8 - 24	3/4"	3/4" - 10 (B)	1 1/8"	12		3/4"	5/8"	110	110	7/8" - 14	1 5/16"	85	125
8"	200	10"	250	2.3	58	3/8 - 24	1"	3/4" - 10	1 1/4"	16	5/8" - 11	1"	13/16"	110	110	1 1/8" - 12	1 13/16"	125	185
10"	250	12"	300	2.8	71	3/8 - 24	1"	7/8" - 9	1 7/16"	20	3/4" - 10	1"	13/16"	160	160	1 1/2" - 12	1 7/8"	252	375
12"	300	16"	400	3.4	86	3/8 - 24	1 1/4"	1 1/8" - 7	1 13/16"	20	3/4" - 10	1"	13/16"	390	390	1 1/2" - 12	2 1/2"	270	400
14"	350			3.9	99	3/8 - 24	1 1/2"	1 1/4" - 7	2"	20	1" - 8	1"	13/16"	545	545	1 1/2" - 12	2 1/2"	280	420
16"	400	20", 24"	600	4.5	114	3/8 - 24	2"	1 1/4" - 7	2"	20	1" - 8	1"	13/16"	545	545	2" - 16	3"	500	750
20"	500			5.63	143	3/4 - 16	1 1/2"	1 3/8" - 6	2 1/8"	24	1" - 8	1"	13/16"	670	670	2 1/4" - 16	3 1/2"	930	N/R
24"	600	30"	800	6.75	165	3/4 - 16*	3/4"	1 1/2" - 12	2 3/8"	24	1 1/8" - 7	1"	13/16"	800	800	3" - 12	Special	1350	N/R

* Adapter p/n 2594101E inside 1/4" - 28"
Grade 5 Bolts
"Heavy" Grade Nuts
Tighten cover nuts in a "star" cross-over pattern

** Must Use ONLY Cla-Val Supplied part

BOLT/NUT TORQUING PROCEDURES ON VALVE COVERS

100-01 Hytrol Main Valve Assembly

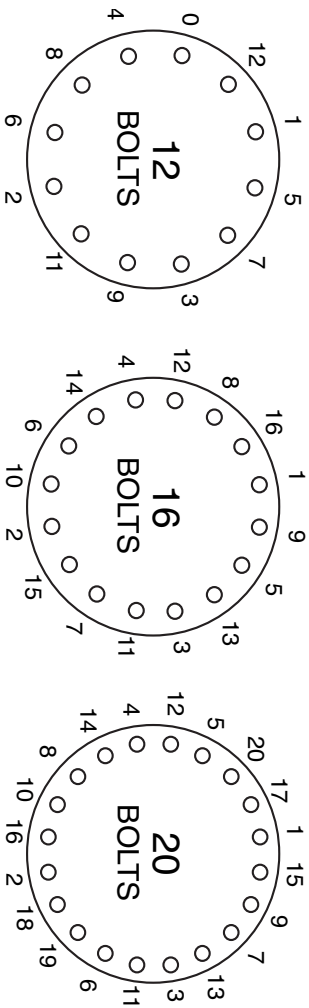
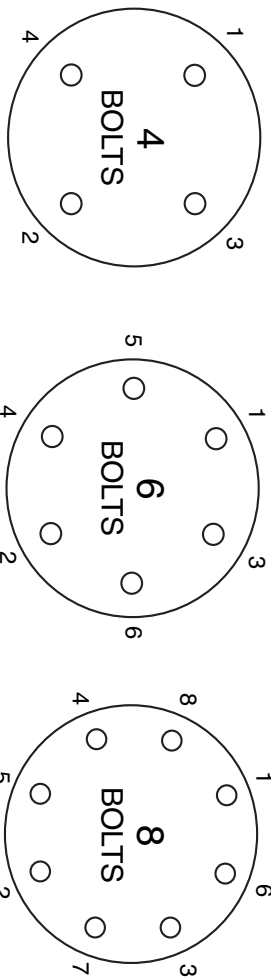

Follow this procedure when reassembling MAIN Valve:

1. Tightens bolts/nuts in a "Star" or "Cross-Over" pattern following the numbers shown above to insure that cover seats evenly on the diaphragm material and body.
2. Torque the bolt/nuts in three stages with a "Star" or "Cross-Over" pattern for each stage:
 - A. To approximately 10% of final torque.
 - B. To approximately 75% of final torque.
 - C. To final required torque.
3. Valves that are to be tested to 375 PSI or higher should be retorqued after 24 hours.

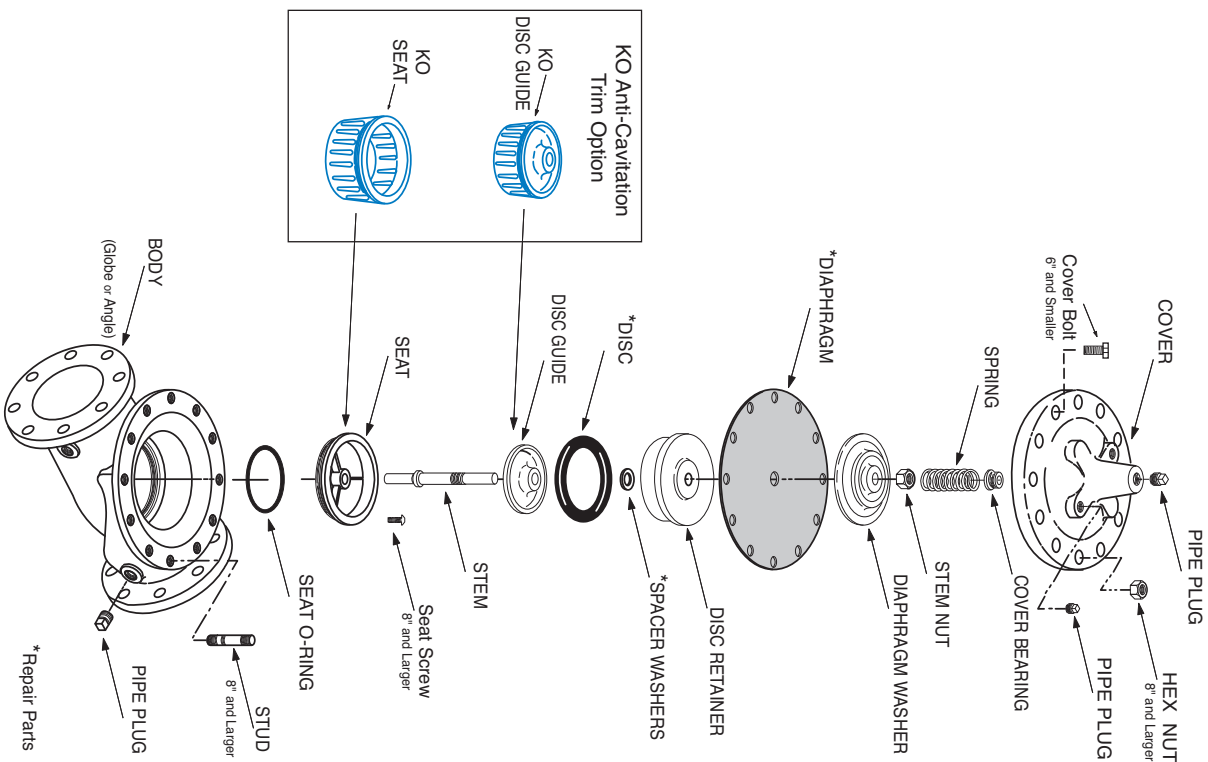



—MODEL— 100-01 Hytrol Valve

Description

The Cla-Val Model 100-01 Hytrol Valve is a main valve for Cla-Val Automatic Control Valves. It is a hydraulically operated, diaphragm-actuated, globe or angle pattern valve.

This valve consists of three major components; body, diaphragm assembly, and cover. The diaphragm assembly is the only moving part. The diaphragm assembly uses a diaphragm of nylon fabric bonded with synthetic rubber. A synthetic rubber disc, contained on three and one half sides by a disc retainer and disc guide, forms a seal with the valve seat when pressure is applied above the diaphragm. The diaphragm assembly forms a sealed chamber in the upper portion of the valve, separating operating pressure from line pressure.

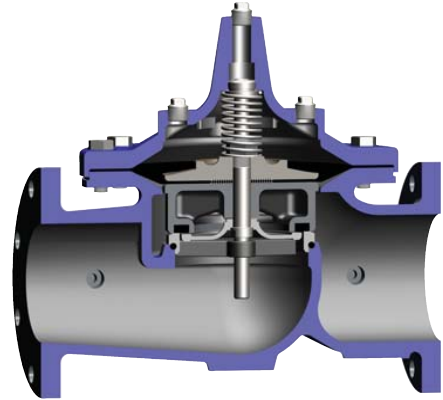

Installation

1. Before valve is installed, pipe lines should be flushed of all chips, scale and foreign matter.
2. It is recommended that either gate or block valves be installed on both ends of the 100-01 Hytrol Valve to facilitate isolating the valve for preventive maintenance and repairs.
3. Place the valve in the line with flow through the valve in the direction indicated on the inlet nameplate. (See "Flow Direction" Section)
4. Allow sufficient room around valve to make adjustments and for disassembly.
5. Cla-Val 100-01 Hytrol Valves operate with maximum efficiency when mounted in horizontal piping with the cover UP, however, other positions are acceptable. Due to size and weight of the cover and internal components of 8 inch and larger valves,

installation with the cover UP is advisable. This makes internal parts readily accessible for periodic inspection.

6. Caution must be taken in the installation of this valve to insure that galvanic and/or electrolytic action does not take place. The proper use of dielectric fittings and gaskets are required in all systems using dissimilar metals.

7. If a pilot control system is installed on the 100-01 Hytrol Valve, use care to prevent damage. If it is necessary to remove fittings or components, be sure they are kept clean and replaced exactly as they were.

8. After the valve is installed and the system is first pressurized, vent air from the cover chamber and pilot system tubing by loosening fittings at all high points.

Principles of Operation

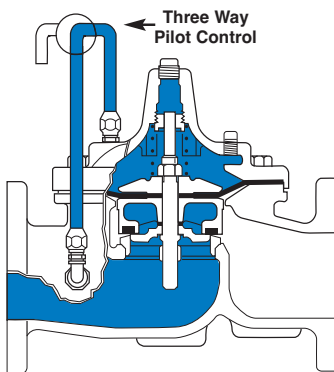

Tight Closing Operation

When pressure from the valve inlet (or an equivalent independent operating pressure) is applied to the diaphragm chamber the valve closes drip-tight.

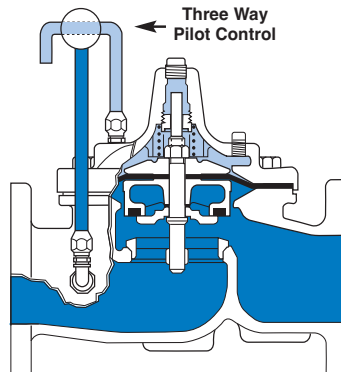

Full Open Operation

When pressure in diaphragm chamber is relieved to a zone of lower pressure (usually atmosphere) the line pressure (5 psi Min.) at the valve inlet opens the valve.

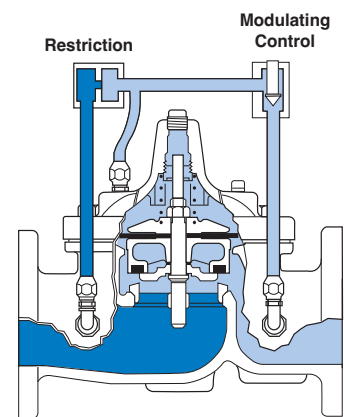

Modulating Action

Valve modulates when diaphragm pressure is held at an intermediate point between inlet and discharge pressure. With the use of a Cla-Val. "modulating control," which reacts to line pressure changes, the pressure above the diaphragm is varied, allowing the valve to throttle and compensate for the change.

Flow Direction

The flow through the 100-01 Hytrol Valve can be in one of two directions. When flow is “up-and-over the seat,” it is in “normal” flow and the valve will fail in the open position. When flow is “over-the seat-and down,” it is in “reverse” flow and the valve will fail in the closed position. There are no permanent flow arrow markings.



Recommended Tools

1. Three pressure gauges with ranges suitable to the installation to be put at Hytrol inlet, outlet and cover connections.
2. Cla-Val Model X101 Valve Position Indicator. This provides visual indication of valve position without disassembly of valve.
3. Other items are: suitable hand tools such as screwdrivers, wrenches, etc. soft jawed (brass or aluminum) vise, 400 grit wet or dry sandpaper and water for cleaning.

Troubleshooting

The following troubleshooting information deals strictly with the Model 100-01 Hytrol Valve. This assumes that all other components of the pilot control system have been checked out and are in proper working condition. (See appropriate sections in Technical Manual for complete valve).

All trouble shooting is possible without removing the valve from the line or removing the cover. It is highly recommended to permanently install a Model X101 Valve Position Indicator and three gauges in unused Hytrol inlet, outlet and cover connections.

SYMPTOM	PROBABLE CAUSE	REMEDY
Fails to Close	Closed isolation valves in control system, or in main line.	Open Isolation valves.
	Lack of cover chamber pressure.	Check upstream pressure, pilot system, strainer, tubing, valves, or needle valves for obstruction.
	Diaphragm damaged. (See Diaphragm Check.)	Replace diaphragm.
	Diaphragm assembly inoperative. Corrosion or excessive scale build up on valve stem. (See Freedom of Movement Check)	Clean and polish stem. Inspect and replace any damaged or badly eroded part.
	Mechanical obstruction. Object lodged in valve. (See Freedom of Movement Check)	Remove obstruction.
	Worn disc. (See Tight Sealing Check)	Replace disc.
	Badly scored seat. (See Tight Sealing Check)	Replace seat.
Fails to Open	Closed upstream and/or downstream isolation valves in main line.	Open isolation valves.
	Insufficient line pressure.	Check upstream pressure. (Minimum 5 psi flowing line pressure differential.)
	Diaphragm assembly inoperative. Corrosion or excessive buildup on valve stem. (See Freedom of Movement Check)	Clean and polish stem. Inspect and replace any damaged or badly eroded part.
	Diaphragm damaged. (For valves in "reverse flow" only)	Replace diaphragm.

After checking out probable causes and remedies, the following three checks can be used to diagnose the nature of the problem before maintenance is started. They must be done in the order shown.

Three Checks

The 100-01 Hytrol Valve has only one moving part (the diaphragm and disc assembly). So, there are only three major types of problems to be considered.

First: Valve is stuck - that is, the diaphragm assembly is not free to move through a full stroke either from open to close or vice versa.

Second: Valve is free to move and can't close because of a worn out diaphragm.

Third: Valve leaks even though it is free to move and the diaphragm isn't leaking.

CAUTION:

Care should be taken when doing the troubleshooting checks on the 100-01 Hytrol Valve. These checks do require the valve to open fully. This will either allow a high flow rate through the valve, or the downstream pressure will quickly increase to the inlet pressure. In some cases, this can be very harmful. Where this is the case, and there are no block valves in the system to protect the downstream piping, it should be realized that **the valve cannot be serviced under pressure.** Steps should be taken to remedy this situation before proceeding any further.

Diaphragm Check (#1)

1. Shut off pressure to the Hytrol Valve by slowly closing upstream and downstream isolation valves. **SEE CAUTION.**
2. Disconnect or close all pilot control lines to the valve cover and leave only one fitting in highest point of cover open to atmosphere.
3. With the cover vented to atmosphere, slowly open upstream isolation valve to allow some pressure into the Hytrol Valve body. Observe the open cover tapping for signs of continuous flow. It is not necessary to fully open isolating valve. Volume in cover chamber capacity chart will be displaced as valve moves to open position. Allow sufficient time for diaphragm assembly to shift position. If there is no continuous flow, you can be quite certain the diaphragm is sound and the diaphragm assembly is tight. If the fluid appears to flow continuously this is a good reason to believe the diaphragm is either damaged or it is loose on the stem. In either case, this is sufficient cause to remove the valve cover and investigate the leakage. (See "Maintenance" Section for procedure.)

COVER CHAMBER CAPACITY (Liquid Volume displaced when valve opens)

Valve size (inches)	Displacement	
	Gallons	Liters
1 1/4	.020	.07
1 1/2	.020	.07
2	.032	.12
2 1/2	.043	.16
3	.080	.30
4	.169	.64
6	.531	2.0
8	1.26	4.8
10	2.51	9.5
12	4.00	15.1
14	6.50	24.6
16	9.57	36.2
20	12.00	45.4
24	29.00	109.8
30	42.00	197.0
36	90.00	340.0

Freedom of Movement Check (#2)

4. Determining the Hytrol Valve's freedom of movement can be done by one of two methods.
5. For most valves it can be done after completing Diaphragm Check (Steps 1, 2, and 3). **SEE CAUTION.** At the end of step 3 the valve should be fully open.
6. If the valve has a Cla-Val X101 Position Indicator, observe the indicator to see that the valve opens wide. Mark the point of maximum opening.
7. Re-connect enough of the control system to permit the application of inlet pressure to the cover. Open pilot system cock so pressure flows from the inlet into the cover.
8. While pressure is building up in the cover, the valve should close smoothly. There is a hesitation in every Hytrol Valve closure, which can be mistaken for a mechanical bind. The stem will appear to stop moving very briefly before going to the closed position. This slight pause is caused by the diaphragm flexing at a particular point in the valve's travel and is not caused by a mechanical bind.
9. When closed, a mark should be made on the X101 Valve position indicator corresponding to the "closed" position. The distance between the two marks should be approximately the stem travel shown in chart.

STEM TRAVEL

(Fully Open to Fully Closed)

Valve Size (inches)		Travel (inches)	
Inches	MM	Inches	MM
1 1/4	32	0.4	10
1 1/2	40	0.4	10
2	50	0.6	15
2 1/2	65	0.7	18
3	80	0.8	20
4	100	1.1	28
6	150	1.7	43
8	200	2.3	58
10	250	2.8	71
12	300	3.4	86
14	350	4.0	100
16	400	4.5	114
20	500	5.6	143
24	600	6.7	165
30	800	7.5	190
36	900	8.5	216

10. If the stroke is different than that shown in stem travel chart this is a good reason to believe something is mechanically restricting the stroke of the valve at one end of its travel. If the flow does not stop through the valve when in the indicated "closed" position, the obstruction probably is between the disc and the seat. If the flow does stop, then the obstruction is more likely in the cover. In either case, the cover must be removed, and the obstruction located and removed. The stem should also be checked for scale build-up. (See "Maintenance, section for procedure.)

11. For valves 6" and smaller, the Hytrol Valve's freedom of movement check can also be done after all pressure is removed from the valve. **SEE CAUTION.** After closing inlet and outlet isolation valves and bleeding pressure from the valve, check that the cover chamber and the body are temporarily vented to atmosphere. Insert fabricated tool into threaded hole in top of valve stem, and lift the diaphragm assembly manually. Note any roughness. The diaphragm assembly should move smoothly throughout entire valve stroke. The tool is fabricated from rod that is threaded on one end to fit valve stem and has a "T" bar handle of some kind on the other end for easy gripping. (See chart in Step 4 of "Disassembly" Section.)

12. Place marks on this diaphragm assembly lifting tool when the valve is closed and when manually positioned open. The distance between the two marks should be approximately the stem travel shown in stem travel chart. If the stroke is different than that shown, there is a good reason to believe something is mechanically restricting the stroke of the valve. The cover must be removed, and the obstruction located and removed. The stem should also be checked for scale build-up. (See "Maintenance" Section for procedure.)

Tight Sealing Check (#3)

13. Test for seat leakage after completing checks #1 & #2 (Steps 1 to 12). **SEE CAUTION.** Close the isolation valve downstream of the Hytrol Valve. Apply inlet pressure to the cover of the valve, wait until it closes. Install a pressure gauge between the two closed valves using one of the two ports in the outlet side of the Hytrol. Watch the pressure gauge. If the pressure begins to climb, then either the downstream isolation valve is permitting pressure to creep back, or the Hytrol is allowing pressure to go through it. Usually the pressure at the Hytrol inlet will be higher than on the isolation valve discharge, so if the pressure goes up to the inlet pressure, you can be sure the Hytrol is leaking. Install another gauge downstream of isolating valve. If the pressure between the valves only goes up to the pressure on the isolation valve discharge, the Hytrol Valve is holding tight, and it was just the isolation valve leaking.

Maintenance

Preventative Maintenance

The Cla-Val Co. Model 100-01 Hytrol Valve requires no lubrication or packing and a minimum of maintenance. However, a periodic inspection schedule should be established to determine how the operating conditions of the system are affecting the valve. The effect of these actions must be determined by inspection.

Disassembly

Inspection or maintenance can be accomplished without removing the valve from the line. Repair kits with new diaphragm and disc are recommended to be on hand before work begins.

WARNING: Maintenance personnel can be injured and equipment damaged if disassembly is attempted with pressure in the valve. **SEE CAUTION.**

1. Close upstream and downstream isolation valves **and independent operating pressure when used** to shut off all pressure to the valve.

2. Loosen tube fittings in the pilot system to remove pressure from valve body and cover chamber. After pressure has been released from the valve, use care to remove the controls and tubing. Note and sketch position of tubing and controls for re-assembly. The schematic in front of the Technical Manual can be used as a guide when reassembling pilot system.

3. Remove cover nuts and remove cover. If the valve has been in service for any length of time, chances are the cover will have to be loosened by driving upward along the edge of the cover with a **dull cold chisel**.

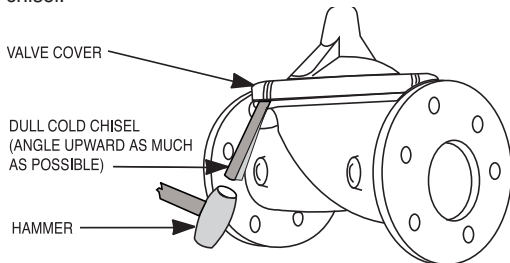

On 6" and smaller valves block and tackle or a power hoist can be used to lift valve cover by inserting proper size eye bolt in place of the center cover plug. on 8" and larger valves there are 4 holes (5/8" – 11 size) where jacking screws and/or eye bolts may be inserted for lifting purposes. **Pull cover straight up** to keep from damaging the integral seat bearing and stem.

COVER CENTER PLUG SIZE

Valve Size	Thread Size (NPT)
1 1/4" – 1 1/2"	1/4"
2" – 3"	1/2"
4" – 6"	3/4"
8" – 10"	1"
12"	1 1/4"
14"	1 1/2"
16"	2"
20" & 24"	2"
30" & 36"	2"

4. Remove the diaphragm and disc assembly from the valve body. With smaller valves this can be accomplished by hand by **pulling straight up on the stem so as not to damage the seat bearing**. On large valves, an eye bolt of proper size can be installed in the stem and the diaphragm assembly can be then lifted with a block and tackle or power hoist. Take care not to damage the stem or bearings. The valve won't work if these are damaged.

VALVE STEM THREAD SIZE

Valve Size	Thread Size (UNF Internal)
1 1/4" – 2 1/2"	10–32
3" – 4"	1/4–28
6" – 14"	3/8–24
16"	1/2–20
20	3/4–16
24"	3/4–16
30"	3/4–16
36"	3/4–16

5. The next item to remove is the stem nut. Examine the stem threads above the nut for signs of mineral deposits or corrosion. If the threads are not clean, use a wire brush to remove as much of the residue as possible. Attach a good fitting wrench to the nut and give it a sharp "rap" rather than a steady pull. Usually several blows are sufficient to loosen the nut for further removal. On the smaller valves, the entire diaphragm assembly can be held by the stem in a vise **equipped with soft brass jaws** before removing the stem nut.

The use of a pipe wrench or a vise without soft brass jaws scars the fine finish on the stem. No amount of careful dressing can restore the stem to its original condition. Damage to the finish of the stem can cause the stem to bind in the bearings and the valve will not open or close.

6. After the stem nut has been removed, the diaphragm assembly breaks down into its component parts. Removal of the disc from the disc retainer can be a problem if the valve has been in service for a long time. Using two screwdrivers inserted along the outside edge of the disc usually will accomplish its removal. Care should be taken to preserve the spacer washers in water, particularly if no new ones are available for re-assembly.

7. The only part left in the valve body is the seat which ordinarily does not require removal. Careful cleaning and polishing of inside and outside surfaces with 400 wet/dry sandpaper will usually restore the seat's sharp edge. If, however, it is badly worn and replacement is necessary, it can be easily removed.

Seats in valve sizes 1 1/4" through 6" are threaded into the valve body. They can be removed with accessory X109 Seat Removing Tool available from the factory. On 8" and larger valves, the seat is held in place by flat head machine screws. Use a tight-fitting, long shank screwdriver to prevent damage to seat screws. If upon removal of the screws the seat cannot be lifted out, it will be necessary to use a piece of angle or channel iron with a hole drilled in the center. Place it across the body so a long stud can be inserted through the center hole in the seat and the hole in the angle iron. By tightening the nut a uniform upward force is exerted on the seat for removal.

NOTE: Do not lift up on the end of the angle iron as this may force the integral bearing out of alignment, causing the stem to bind.

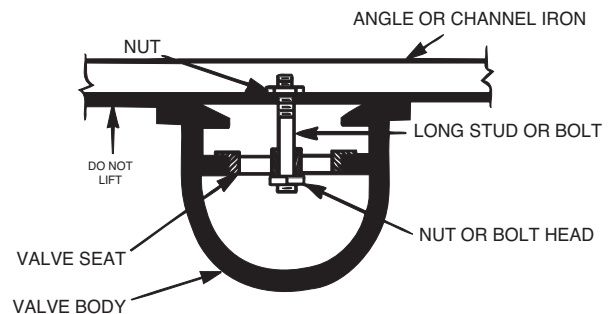

Lime Deposits

One of the easiest ways to remove lime deposits from the valve stem or other metal parts is to dip them in a 5-percent muriatic acid solution just long enough for the deposit to dissolve. This will remove most of the common types of deposits. **CAUTION: USE EXTREME CARE WHEN HANDLING ACID.** Rinse parts in water before handling. If the deposit is not removed by acid, then a fine grit (400) wet or dry sandpaper can be used with water.

Inspection of Parts

After the valve has been disassembled, each part should be examined carefully for signs of wear, corrosion, or any other abnormal condition. Usually, it is a good idea to replace the rubber parts (diaphragm and disc) unless they are free of signs of wear. These are available in a repair kit. Any other parts which appear doubtful should be replaced. **WHEN ORDERING PARTS, BE SURE TO GIVE COMPLETE NAMEPLATE DATA, ITEM NUMBER AND DESCRIPTION.**

NOTE: If a new disc isn't available, the existing disc can be turned over, exposing the unused surface for contact with the seat. The disc should be replaced as soon as practical.

Reassembly

1. Reassembly is the reverse of the disassembly procedure. If a new disc has been installed, it may require a different number of spacer washers to obtain the right amount of "grip" on the disc. When the diaphragm assembly has been tightened to a point where the diaphragm cannot be twisted, the disc should be compressed very slightly by the disc guide. Excessive compression should be avoided. Use just enough spacer washers to hold the disc firmly without noticeable compression.

2. **MAKE SURE THE STEM NUT IS VERY TIGHT.** Attach a good fitting wrench to the nut and give it a sharp "rap" rather than a steady pull. Usually several blows are sufficient to tighten the stem nut for final tightening. Failure to do so could allow the diaphragm to pull loose and tear when subjected to pressure.

3. Carefully install the diaphragm assembly by lowering the stem through the seat bearing. Take care not to damage the stem or bearing. Line up the diaphragm holes with the stud or bolt holes on the body. On larger valves with studs, it may be necessary to hold the diaphragm assembly up part way while putting the diaphragm over the studs.

4. Put spring in place and replace cover. Make sure diaphragm is lying smooth under the cover.

5. Tighten cover nuts firmly using a cross-over pattern until all nuts are tight.

6. Test Hytrol Valve before re-installing pilot valve system.

Test Procedure After Valve Assembly

There are a few simple tests which can be made in the field to make sure the Hytrol Valve has been assembled properly. Do these before installing pilot system and returning valve to service. These are similar to the three troubleshooting tests.

1. Check the diaphragm assembly for freedom of movement after all pressure is removed from the valve. **SEE CAUTION.** Insert fabricated tool into threaded hole in top of valve stem, and lift the diaphragm assembly manually. Note any roughness, sticking or grabbing. The diaphragm assembly should move smoothly throughout entire valve stroke. The tool is fabricated from rod that is threaded on one end to fit valve stem (See chart in Step 4 of "Disassembly" section.) and has a "T" Bar handle of some kind on the other end for easy gripping.

Place marks on this diaphragm assembly lifting tool when the valve is closed and when manually positioned open. The distance between the two marks should be approximately the stem travel shown in stem travel chart. (See "Freedom of Movement Check" section.) If the stroke is different than that shown, there is a good reason to believe something is mechanically restricting the stroke of the valve. The cover must be removed, the obstruction located and removed. (See "Maintenance" Section for procedure.)

Due to the weight of the diaphragm assembly this procedure is not possible on valves 8" and larger. On these valves, the same determination can be made by carefully introducing a low pressure-less than five psi) into the valve body with the cover vented. **SEE CAUTION.** Looking in cover center hole see the diaphragm assembly lift easily without hesitation, and then settle back easily when the pressure is removed.

2. To check the valve for drip-tight closure, a line should be connected from the inlet to the cover, and pressure applied at the inlet of the valve. If properly assembled, the valve should hold tight with as low as ten PSI at the inlet. See "Tight Sealing Check" section.)

3. With the line connected from the inlet to the cover, apply full working pressure to the inlet. Check all around the cover for any leaks. Re-tighten cover nuts if necessary to stop leaks past the diaphragm.

4. Remove pressure, then re-install the pilot system and tubing exactly as it was prior to removal. **Bleed air from all high points.**

5. Follow steps under "Start-Up and Adjustment" Section in Technical Manual for returning complete valve back to service.

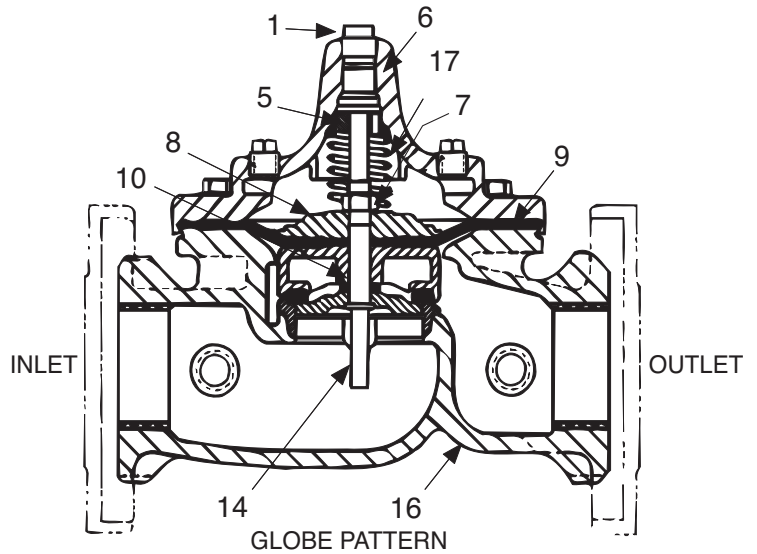
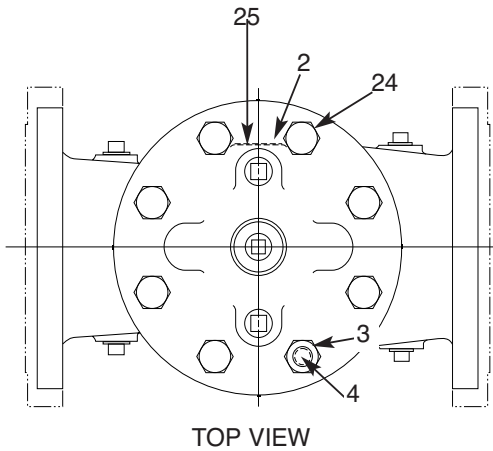

PARTS LIST

Item	Description
1.	Pipe Plug
2.	Drive Screws (for nameplate)
3.	Hex Nut (8" and larger)
4.	Stud (8" and larger)
5.	Cover Bearing
6.	Cover
7.	Stem Nut
8.	Diaphragm Washer
9.	Diaphragm
10.	Spacer Washers
11.	Disc Guide
12.	Disc Retainer
13.	Disc
14.	Stem
15.	Seat
16.	Body
17.	Spring
22.	Flat Head Screws (8" and larger)
23.	Seat O-Ring
24.	Hex head Bolt (1 1/4" thru 4")
25.	Nameplate
26.	Upper Spring Washer (Epoxy coated valves only)
27.	Lower Spring Washer (Epoxy coated valves only)
28.	Cover Bearing Housing (16" only)
29.	Cover O-Ring (16" only)
30.	Hex Bolt (16" only)
31.	Pipe Cap (16" only)

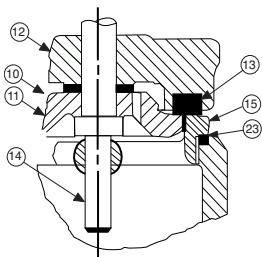
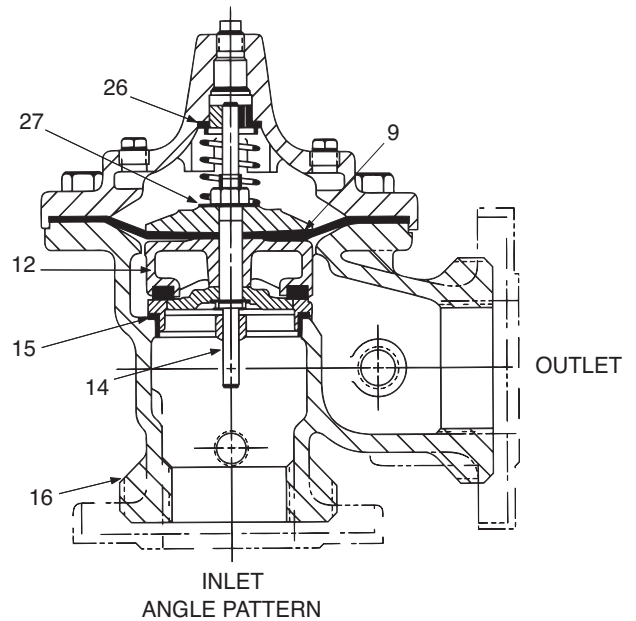

1 1/4" - 6" SEAT DETAIL

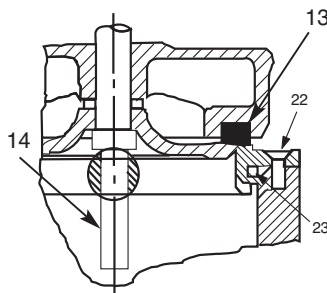

8" - 24" SEAT DETAIL

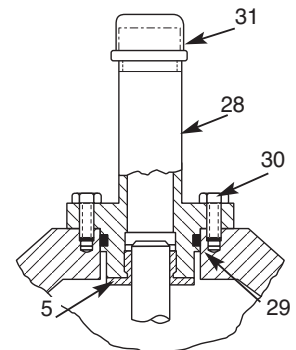

16" COVER DETAIL



— MODEL — 100-01 Hytrol Valve Service Data

Description 100-01 Hytrol Valve

The Cla-Val Model 100-01 Hytrol Valve is a main valve for Cla-Val Automatic Control Valves. It is a hydraulically operated, diaphragm-actuated, globe or angle pattern valve.

This valve consists of three major components; body, diaphragm assembly, and cover. The diaphragm assembly is the only moving part. The diaphragm assembly uses a diaphragm of nylon fabric bonded with synthetic rubber. A synthetic rubber disc, contained on three and one half sides by a disc retainer and disc guide, forms a seal with the valve seat when pressure is applied above the diaphragm. The diaphragm assembly forms a sealed chamber in the upper portion of the valve, separating operating pressure from line pressure.

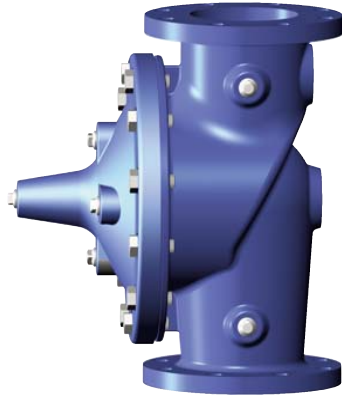

Description 100-20 600 Series Hytrol Valve

The Cla-Val Model 100-20 Hytrol Valve (600 Series main valve) have only one part -the body- that is different from standard 100 Series Cla-Val main valve parts. The remaining parts of the 600 series main valve are standard Cla-Val main valve parts. All service and maintenance information for the standard 100 Series main valves also apply to the 600 series main valves.

The most important thing to remember when ordering main valve repair kits and replacement parts, except for the body, all other parts are going to be for a smaller size main valve. Cla-Val identifies main valve parts with the flange size of the standard 100 Series main valve. Refer to the "Main Valve Sizes" chart below.

HYTROL Service Data

HYTROL SIZE		Stem Travel		Cover Capacity Displacement		Valve Stem Thread	Center Plug	Cover Nut or Bolt			Cover Lifting Holes	Cover Plug		Cover Torque		Stem Nut**		Stem Nut Torque	
100-01	100-20	inches	mm	inches	mm	UNF-Internal	NPT	Thread (Bolt)	Socket	Qty	UNC	Thread	Socket	ft. Lbs.	in. Lbs.	Thread	Socket (Long)	Lubed	DRY
1"	25			0.3	8		1/4"	1/4" - 20 (B)	7/16"	8				4	48	3/8" - 24		4	6
1 1/4"	32			0.4	10	0.020	1/4"	5/16" - 18 (B)	1/2"	8				8	96	7/16" - 20		6	10
1 1/2"	40			0.4	10	0.020	1/4"	5/16" - 18 (B)	1/2"	8				8	96	7/16" - 20		6	10
2"	50			0.6	15	0.032	1/2"	3/8" - 16 (B)	9/16"	8		3/8"	7/16"	12	12	1/2" - 20	3/4"	10	15
2 1/2"	65			0.7	18	0.043	1/2"	7/16" - 14 (B)	5/8"	8		1/2"	9/16"	20	20	5/8" - 18	15/16"	21	30
3"	80	4"	100	0.8	20	0.080	1/2"	1/2" - 13 (B)	3/4"	8		1/2"	9/16"	30	30	5/8" - 18	15/16"	21	30
4"	100	6"	150	1.1	23	0.169	3/4"	3/4" - 10 (B)	1 1/8"	8		3/4"	5/8"	110	110	3/4" - 16	1 1/16"	40	60
6"	150	8"	200	1.7	43	0.531	3/4"	3/4" - 10 (B)	1 1/8"	12		3/4"	5/8"	110	110	7/8" - 14	1 5/16"	85	125
8"	200	10"	250	2.3	58	1.26	1"	3/4" - 10	1 1/4"	16	5/8" - 11	1"	13/16"	110	110	1 1/8" - 12	1 13/16"	125	185
10"	250	12"	300	2.8	71	2.51	1"	7/8" - 9	1 7/16"	20	3/4" - 10	1"	13/16"	160	160	1 1/2" - 12	1 7/8"	252	375
12"	300	16"	400	3.4	86	4.0	1 1/4"	1 1/8" - 7	1 13/16"	20	3/4" - 10	1"	13/16"	390	390	1 1/2" - 12	2 1/2"	270	400
14"	350			3.9	99	6.5	1 1/2"	1 1/4" - 7	2"	20	1" - 8	1"	13/16"	545	545	1 1/2" - 12	2 1/2"	280	420
16"	400	20", 24"	600	4.5	114	9.6	2"	1 1/4" - 7	2"	20	1" - 8	1"	13/16"	545	545	2" - 16	3"	500	750
20"	500			5.63	143	12	1 1/2"	1 3/8" - 6	2 1/8"	24	1" - 8	1"	13/16"	670	670	2 1/4" - 16	3 1/2"	930	N/R
24"	600	30"	800	6.75	165	29.0	3/4"	1 1/2" - 12	2 3/8"	24	1 1/8" - 7	1"	13/16"	800	800	3" - 12	Special	1350	N/R

* Adapter p/n 2594101E inside 1/4" - 28"

Grade 5 Bolts "Heavy" Grade Nuts Tighten cover nuts in a "star" cross-over pattern

** Must Use ONLY Cla-Val Supplied part

BOLT/NUT TORQUING PROCEDURES ON VALVE COVERS

100-01 Hytrol Main Valve Assembly

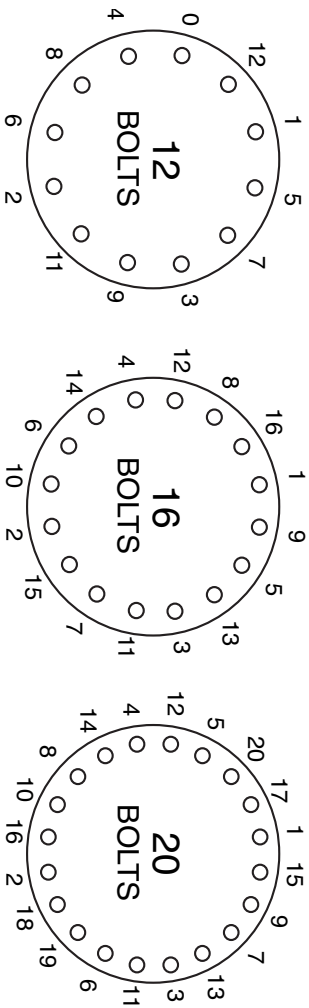
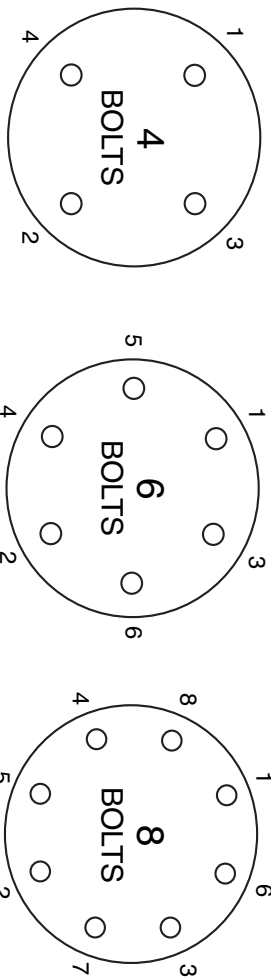

Follow this procedure when reassembling MAIN Valve:

1. Tightens bolts/nuts in a "Star" or "Cross-Over" pattern following the numbers shown above to insure that cover seats evenly on the diaphragm material and body.
2. Torque the bolt/nuts in three stages with a "Star" or "Cross-Over" pattern for each stage:
 - A. To approximately 10% of final torque.
 - B. To approximately 75% of final torque.
 - C. To final required torque.
3. Valves that are to be tested to 375 PSI or higher should be retorqued after 24 hours.

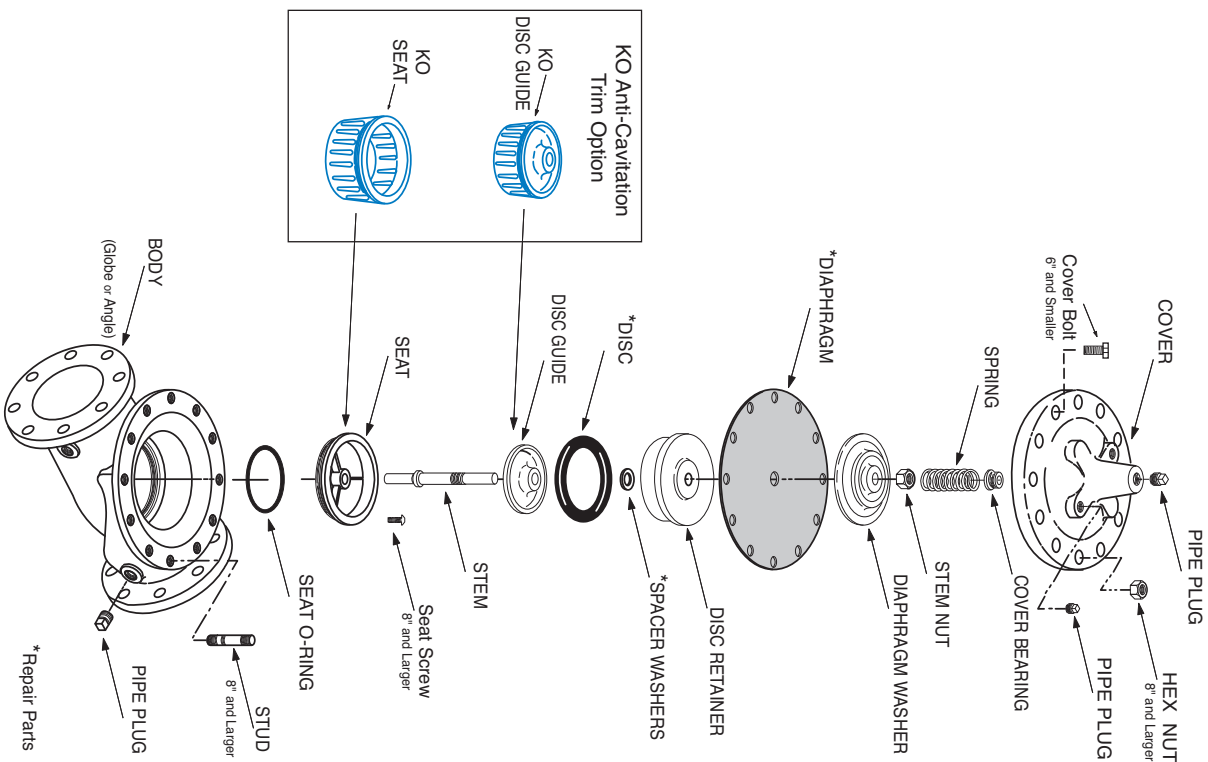



— MODEL — **CRD**

Pressure Reducing Control



DESCRIPTION

The Cla-Val Model CRD Pressure Reducing Control automatically reduces a higher inlet pressure to a lower outlet pressure. It is a direct acting, spring loaded, diaphragm type control that operates hydraulically or pneumatically. It may be used as a self-contained valve or as a pilot control for a Cla-Val main valve. It will hold a constant downstream pressure within very close pressure limits.

OPERATION

The CRD Pressure Reducing Control is normally held open by the force of the compression spring above the diaphragm; and delivery pressure acts on the underside of the diaphragm. Flow through the valve responds to changes in downstream demand to maintain a pressure.

INSTALLATION

The CRD Pressure Reducing Control may be installed in any position. There is one inlet port and two outlets, for either straight or angle installation. The second outlet port can be used for a gage connection. A flow arrow is marked on the body casting.

ADJUSTMENT PROCEDURE

The CRD Pressure Reducing Control can be adjusted to provide a delivery pressure range as specified on the nameplate. Pressure adjustment is made by turning the adjustment screw to vary the spring pressure on the diaphragm. The greater the compression on the spring the higher the pressure setting.

1. Turn the adjustment screw in (clockwise) to increase delivery pressure.
2. Turn the adjustment screw out (counter-clockwise) to decrease the delivery pressure.
3. When pressure adjustment is completed tighten jam nut on adjusting screw and replace protective cap.
4. When this control is used, as a pilot control on a Cla-Val main valve, the adjustment should be made under flowing conditions. The flow rate is not critical, but generally should be somewhat lower than normal in order to provide an inlet pressure several psi higher than the desired setting

The approximate minimum flow rates given in the table are for the main valve on which the CRD is installed.

Valve Size	1 1/4" -3"	4"-8"	10"-16"
Minimum Flow GPM	15-30	50-200	300-650

SYMPTOM	PROBABLE CAUSE	REMEDY
Fails to open when delivery pressure lowers	No spring compression	Tighten adjusting screw
	Damaged spring	Disassemble and replace
	Spring guide (8) is not in place	Assemble properly
	Yoke dragging on inlet nozzle	Disassemble and reassemble properly (refer to Reassembly)
Fails to close when delivery pressure rises	Spring compressed solid	Back off adjusting screw
	Mechanical obstruction	Disassemble and reassemble properly (refer to Reassembly)
	Worn disc	Disassemble remove and replace disc retainer assembly
	Yoke dragging on inlet nozzle	Disassemble and reassemble properly (refer to Reassembly)
Leakage from cover vent hole	Damaged diaphragm	Disassemble and replace
	Loose diaphragm nut	Remove cover and tighten nut

MAINTENANCE

Disassembly

To disassemble follow the sequence of the item numbers assigned to parts in the sectional illustration.

Reassembly

Reassembly is the reverse of disassembly. Caution must be taken to avoid having the yoke (17) drag on the inlet nozzle of the body (18). Follow this procedure:

1. Place yoke (17) in body and screw the disc retainer assembly (16) until it bottoms.
2. Install gasket (14) and spring (19) for 2-30 and 2-6.5 psi range onto plug (13) and fasten into body. Disc retainer must enter guide hole in plug as it is assembled. Screw the plug in by hand. Use wrench to tighten only.
3. Place diaphragm (12) diaphragm washer (11) and Belleville washer (20) on yoke. Screw on hex nut (10).
4. Hold the diaphragm so that the screw holes in the diaphragm and body align. Tighten diaphragm nut with a wrench. At the final tightening release the diaphragm and permit it to rotate 5° to 10°. The diaphragm holes should now be properly aligned with the body holes.

To check for proper alignment proceed as follows:

Rotate diaphragm clockwise and counterclockwise as far as possible. Diaphragm screw holes should rotate equal distance on either side of body screw holes ±1/8".

Repeat assembly procedure until diaphragm and yoke are properly aligned. There must be no contact between yoke and body nozzle during its normal movement. To simulate this movement hold body and diaphragm holes aligned. Move yoke to open and closed positions. There must be no evidence of contact or dragging.

5. Install spring (9) with spring guide (8).
6. Install cover (5), adjusting screw (2) and nut (3), then cap (1).



CRD

Pressure Reducing Control

(Bronze Body with 303SS Trim)

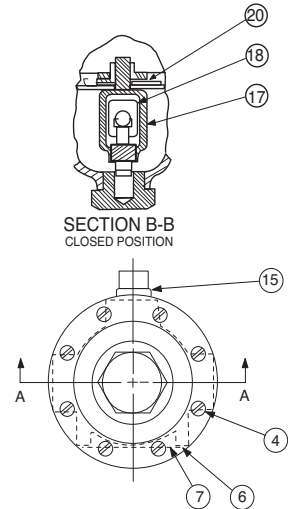
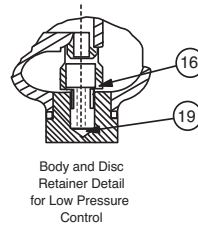
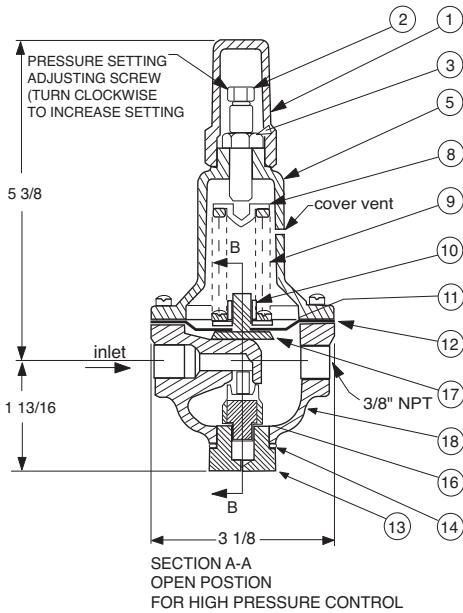

Size (inch)	Stock Number	Adjustment Range	
		psi	Ft of Water
3/8	7194307A	2 - 6.5	4.5 - 15
3/8	7194308J	2 - 30	4.5 - 69
3/8	7194303K	15 - 75	35 - 173
3/8	7194311C	20 - 105	46 - 242
3/8	7194304H	30 - 300	69 - 692
Factory Set Pressure		PSI per Turn*	
2 - 6.5 set @ 3.5 psi		.61	
2 - 30 set @ 10 psi		3.0	
15 - 75 set @ 20 psi		9.0	
20 - 105 set @ 60 psi		12.0	
30 - 300 set @ 60 psi		27.0	

*Approximate-Final Adjustment should be with a pressure gauge and with flow.

When ordering parts specify:

- All nameplate data
- Item Description
- Item number

Item	Description	Material	Part Number	List Price
1	Cap	PL	67628J	
2	Adjusting Screw	BRS	7188201D	
3	Jam Nut (3/8-16)	SS	6780106J	
4*	Machine Screw (Fil.Hd.) 8 Req'd	303	6757821B	
5	Cover	BRS	C2544K	
6	Nameplate Screw	SS	67999D	
7	Nameplate	BRS	C0022001G	
8	Spring Guide	302	71881H	
	Spring Guide (20 - 105 psi)	303	205620F	
9	Spring (15-75 psi)	CHR/VAN	71884B	
	Spring (2 - 6.5 psi)	SS	82575C	
	Spring (2 - 30 psi)	SS	81594E	
	Spring (20 - 105 psi)	316	20632101E	
	Spring (30 - 300 psi)	CHR/VAN	71885J	
10	Hex Nut	303	71883D	
11	Diaphragm Washer	302	71891G	
12*	Diaphragm	NBR	C6936D	
13	Plug, Body	BRS	V5653A	
14*	Gasket	Fiber	40174F	
15	Plug	BRS	6766003F	
16*	Disc Retainer Assy. (2 - 30 psi)	SS/Rub	C8348K	
	Disc Retainer Assy. (15 - 75 psi)	SS/Rub	37133G	
	Disc Retainer Assy. (20 - 105 psi)	SS/Rub	37133G	
	Disc Retainer Assy. (30 - 300 psi)	SS/Rub	37133G	
17	Yoke	VBZ	V6951H	
18	Body & 1/4" Seat Assy	BR/SS	8339702G	
19*	Bucking Spring (2 - 6.5 psi)(2 - 30psi)	302	V0558G	
20	Belleville Washer	STL	7055007E	
*	Repair Kit (No Bucking Spring)	Buna®-N	9170003K	
*	Repair Kit (with Bucking Spring)	Buna®-N	9170002B	

*SUGGESTED REPAIR PARTS



Regulator Spring Color Coding Chart

Dwg#47117

*THESE FIGURES ARE ONLY APPROXIMATE. FINAL ADJUSTMENTS SHOULD BE MADE WITH A PRESSURE GAGE.

WIRE SIZE	SPRING NUMBER	COLOR	WIRE MATERIAL	CATALOG NUMBER	PSI RANGE	*PSI PER TURN
.080 DIA.	C0492D	BLUE	S.S.	CDB-7	0-7	.75
				CRL-5A	0-7	.75
.018 DIA.	82575C	--	S.S.	CRD	1.9-6.5	.61
				CRD-10A	1.9-6.5	.49
.116 DIA.	81594E	--	S.S.	CRD	2-30	3.0
				CRD-10A	2-30	2.4
.120 DIA.	V5654J	GREEN	CHR VAN	CRL-5A	5-25	4.0
				CRD	10-40	4.0
.162 DIA.	32447F	NATURAL	S.S.	CDB-7	10-60	12.0
				CRL-5A	10-60	12.0
				CRL-13	10-60	12.0
.162 DIA.	V5695B	YELLOW	MUSIC WIRE	CDB-7	20-80	14.5
				CRL-5A	20-80	14.5
				CRL-13	20-80	14.5
.207 DIA.	C1124B	CAD PLT	MUSIC WIRE	CDB-7	50-150	29.5
				CRL-13	50-150	29.5
				CRL-5A	50-150	29.5
.225 DIA.	V6515A	RED	MUSIC WIRE	CDB-7	65-180	44.0
				CRL-13	65-180	44.0
				CRL-5A	65-180	44.0
.115 X .218	71884B	RED	CHR VAN	CRL	0-75	8.5
				CRD	15-75	9.0
				CRD-10A	15-75	7.2
.118 X .225	71885J	GREEN	CHR VAN	CRL	20-200	28.0
				CRD	30-300	27.0
				CRD-10A	30-300	22.4
.225 X .295	1630201A	CAD PLT	CHR VAN	CRL	100-300	18.00
				CRL-5A	100-300	18.00
.440 X .219	48211H	CAD PLT	STEEL	CRA-18	200-450	17.0
				CRD-22	200-450	17.0
				CRL-4A	100-450	17.0
.187	20632101E	BLACK	316 SST	CRD	20-105	13.0
				CRL	20-105	13.0
WIRE SIZE	SPRING NUMBER	COLOR	WIRE MATERIAL	CATALOG NUMBER	FEET RANGE	*FEET PER TURN
.080 DIA.	C0492D	BLUE	S.S.	CRA	4.5-15	.82
				CRD-2	4.5-15	.82
.375 DIA.	87719B	EPOXY COATED	CHROME SILICON	CDS-5	5-40	1.0
	1 SPRING			30-80	2.0	
	2 SPRING			70-120	3.0	
	3 SPRING			110-120	4.0	
	4 SPRING			150-200	5.0	
.072 DIA.	V5097A	--	302SS	CVC	1-17	.7
					5 SPRING	
.375 DIA.	2933502H	EPOXY COATED	CHROME SILICON	CDS-6A	5-40	.75
	1 SPRING			30-80	1.50	
	2 SPRING			70-120	2.20	
	3 SPRING			110-160	3.00	
	4 SPRING			150-200	3.70	

THE FOLLOWING CONTROL & SPRING P/N'S WERE REMOVED, 32656B, 31554K, 44591G, V65695B, & V5695B. ADDED CRL-13, CRL-5A, CRA, CRA-10A, CHANGED SPRING RANGES TO MATCH CURRENT CONTROLS.

*This drawing is the property of CLA-VAL and same and copies made thereof, if any, shall be returned to it upon demand. Delivery and disclosure hereof are made solely upon condition that the same shall not be used, copied or reproduced, nor shall the subject here of be disclosed in any manner to anyone for any purpose, except as herein authorized, without prior approval of CLA-VAL. Whether or not the equipment or information shown hereon is patented or otherwise protected, full title and copy-rights if any, in and to this drawing and/or information delivered or submitted are fully reserved by CLA-VAL.



— MODEL — **X46**

Flow Clean Strainer



X46A Straight

- Self Scrubbing Cleaning Action
- Straight Type or Angle Type

The Cla-Val Model X46 Strainer is designed to prevent passage of foreign particles larger than .015". It is especially effective against such contaminant as algae, mud, scale, wood pulp, moss, and root fibers. There is a model for every Cla-Val. valve.

X46B Angle

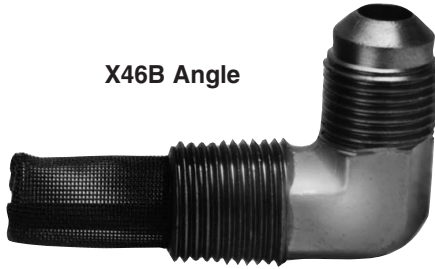

The X46 Flow Clean strainer operates on a velocity principle utilizing the circular "air foil" section to make it self cleaning. Impingement of particles is on the "leading edge" only. The low pressure area on the downstream side of the screen prevents foreign particles from clogging the screen. There is also a scouring action, due to eddy currents, which keeps most of the screen area clean.

Dimensions (In Inches)

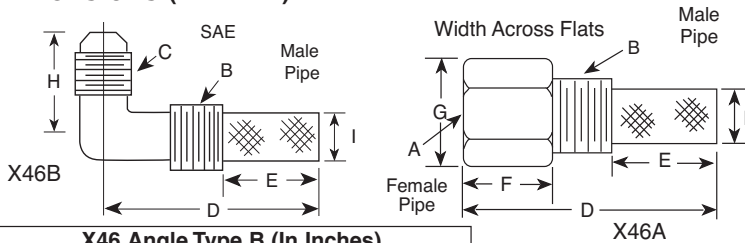

X46 Angle Type B (In Inches)

B(NPT)	C(SAE)	D	E	H	I
1/8	1/4	1-3/8	5/8	7/8	1/4
1/4	1/4	1-3/4	3/4	1	3/8
3/8	1/4	2	7/8	1	1/2
3/8	3/8	1-7/8	7/8	1	1/2
1/2	3/8	2-3/8	1	1-1/4	5/8

X46A Straight Type A (In Inches)						
A (NPT)	B (NPT)	D	E	F	G	I
1/8	1/8	1-3/4	3/4	1/2	1/2	1/4
1/4	1/4	2-1/4	1	3/4	3/4	3/8
3/8	3/8	2-1/2	1	7/8	7/8	1/2
3/8	1/2	2-1/2	1-1/4	1/2	7/8	3/4
1/2	1/2	3	1-1/4	1	1-1/8	3/4
3/8	3/4	3-3/8	2	1/2	1	7/8
3/4	3/4	4	2	1	1-1/2	7/8
3/8	1	4-1/4	2-3/4	1/2	1-3/8	7/8
1	1	4-1/2	2-3/4	1-1/4	1-3/4	7/8
1/2	1	4-1/4	2-3/4	1/2	1-3/8	7/8

When Ordering, Please Specify:

- Catalog Number X46
- Straight Type or Angle Type
- Size Inserted Into and Size Connection
- Materials

INSTALLATION

The strainer is designed for use in conjunction with a Cla-Val Main Valve, but can be installed in any piping system where there is a moving fluid stream to keep it clean. When it is used with the Cla-Val Valve, it is threaded into the upstream body port provided for it on the side of the valve. It projects through the side of the Main Valve into the flow stream. All liquid shunted to the pilot control system and to the cover chamber of the Main Valve passes through the X46 Flow Clean Strainer.

INSPECTION

Inspect internal and external threads for damage or evidence of cross-threading. Check inner and outer screens for clogging, embedded foreign particles, breaks, cracks, corrosion, fatigue, and other signs of damage.

DISASSEMBLY

Do not attempt to remove the screens from the strainer housing.

CLEANING

After inspection, cleaning of the X46 can begin. Water service usually will produce mineral or lime deposits on metal parts in contact with water. These deposits can be cleaned by dipping X46 in a 5-percent muriatic acid solution just long enough for deposit to dissolve. This will remove most of the common types of deposits. **Caution: use extreme care when handling acid.** If the deposit is not removed by acid, then a fine grit (400) wet or dry sandpaper can be used with water. Rinse parts in water before handling. An appropriate solvent can clean parts used in fueling service. Dry with compressed air or a clean, lint-free cloth. Protect from damage and dust until reassembled.

REPLACEMENT

If there is any sign of damage, or if there is the slightest doubt that the Model X46 Flow Clean Strainer may not afford completely satisfactory operation, replace it. Use Inspection steps as a guide. Neither inner screen, outer screen, nor housing is furnished as a replacement part. Replace Model X46 Flow Clean Strainer as a complete unit.

When ordering replacement Flow-Clean Strainers, it is important to determine pipe size of the tapped hole into which the strainer will be inserted (refer to column A or F), and the size of the external connection (refer to column B or G).

AK	07-10-08	BB	ADDED PN'S 67783-62B (NED 62200)
AK	08-14-08	BC	ADDED PN'S 67783-63K (NED 62218)
PC	10-1-2008	BD	ADDED PN 67783-64H (NED 62446)
CAD REVISION RECORD - DO NOT REVISE MANUALLY		BY	DATE
LTR	DESCRIPTION		
A-AY	SEE REVISION FILE		
BA	ADDED PN'S 67783-59H, 67783-60F & 67783-61D (ECO 20434)	AK	03-14-06

 CLA-VAL CO. NEWPORT BEACH, CALIFORNIA	CATALOG NO.	DRAWING NO.	REV
		67783	BD
TYPE OF VALVE AND MAIN FEATURES		DESIGN	
<h1>CK2 COCK/BALL VALVE</h1>		DRAWN	MGR 4-02-80
		CHK'D	KD 4-03-80
		APV'D	CH 4-07-80

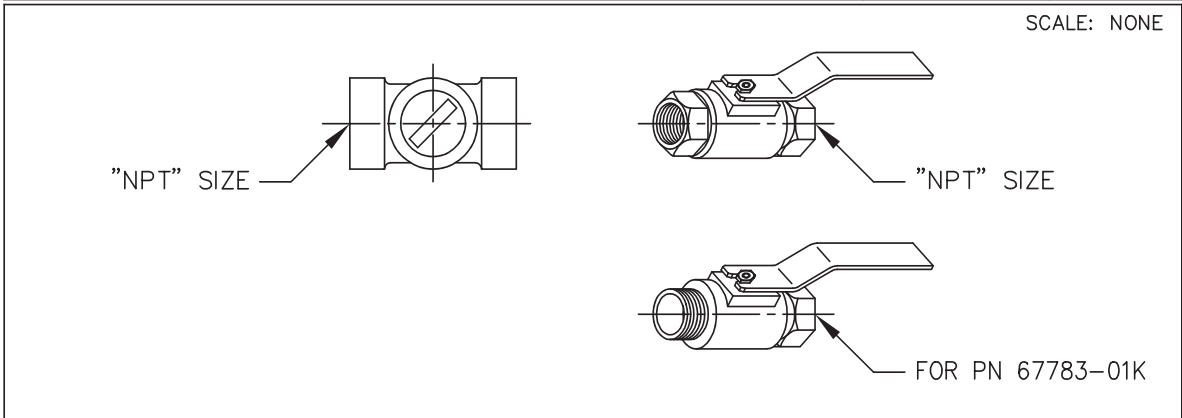

CLA-VAL PART NO. AND MATERIAL								
BRONZE WITH HANDLE	STEEL WITH HANDLE	IRON WITH HANDLE	316 SST WITH HANDLE	316 SST W/ LOCKING HANDLE	BRONZE WITH HANDLE	MONEL WITH HANDLE	MONEL W/ LOCKING HANDLE	SIZE "NPT"
67783-01K*	-09C	-17F	-25J SUPSD BY-26G		-41F SUPSD BY-01K			1/8"
-02H	-10A	-18D	-26G	-51E SUPSD BY-26G -52C	-42D SUPSD BY-02H	-55F		1/4"
-03F * -59H***	-11J	-19B	-27E	-46E SUPSD BY-27E -53A	-45G -57B * *	-48A SUPSD BY-49J	-63K	3/8"
-04D -60F ***	-12G	-20K	-28C	-54J	-43B SUPSD BY-04D	-49J	-62B	1/2"
-05A -61D ***	-13E	-21H	-29A	-64H	-44K SUPSD BY-05A	-56D		3/4"
-06J	-14C	-22F	-30J			-58K		1"
-07G	-15K	-23D	-31G					1 1/4"
-08E	-16H	-24B	-32E					1 1/2"
-50G			-47C					2"

- * SEE ENGINEERING APPROVED VENDORS TABLE (SHEET 2 OF 2).
- ** HAMMOND VALVE 8501 ONLY.
- *** WILKINS CK2 (SEE SHEET 2 OF 2)

THIS DRAWING IS THE PROPERTY OF CLA-VAL CO. AND SAME AND COPIES MADE THEREOF, IF ANY, SHALL BE RETURNED TO IT UPON DEMAND. DELIVERY AND DISCLOSURE HEREOF ARE SOLELY UPON CONDITION THAT THE SAME SHALL NOT BE USED, COPIED OR REPRODUCED, NOR SHALL THE SUBJECT HEREOF BE DISCLOSED IN ANY MANNER TO ANYONE FOR ANY PURPOSE, EXCEPT AS HEREIN AUTHORIZED, WITHOUT PRIOR WRITTEN APPROVAL OF CLA-VAL CO. THIS DRAWING IS SUBMITTED CONFIDENTIALLY AND MAY NOT BE USED IN THE MANUFACTURE OF ANY MATERIAL OR PRODUCT OTHER THAN SUCH MATERIALS AND PRODUCTS FURNISHED TO CLA-VAL CO. WHETHER OR NOT THE EQUIPMENT OR INFORMATION SHOWN HEREON IS PATENTED OR OTHERWISE PROTECTED, FULL TITLE AND COPYRIGHTS, IF ANY, IN AND TO THIS DRAWING AND/OR INFORMATION DELIVERED OR SUBMITTED ARE FULLY RESERVED CLA-VAL CO.



— MODEL — **CV**
Flow Control



DESCRIPTION

The Cla-Val Model CV Flow Control is a simply-designed, spring-loaded check valve. Rate of flow is full flow in one direction and restricted in other direction. Flow is adjustable in the restricted direction. It is intended for use in conjunction with a pilot control system on a Cla-Val Automatic Control Valve.

OPERATION

The CV Flow Control permits full flow from port A to B, and restricted flow in the reverse direction. Flow from port A to B lifts the disc from seat, permitting full flow. Flow in the reverse direction seats the disc, causing fluid to pass through the clearance between the stem and the disc. This clearance can be increased, thereby increasing the restricted flow, by screwing the stem out, or counter-clockwise. Turning the stem in, or clockwise reduces the clearance between the stem and the disc, thereby reducing the restricted flow.

INSTALLATION

Install the CV Flow Control as shown in the valve schematic. All connections must be tight to prevent leakage.

DISASSEMBLY

Follow the sequence of the item numbers assigned to the parts in the cross sectional illustration for recommended order of disassembly.

Use a scriber, or similar sharp-pointed tool to remove O-ring from the stem.

INSPECTION

Inspect all threads for damage or evidence of cross-threading. Check mating surface of seat and valve disc for excessive scoring or embedded foreign particles. Check spring for visible distortion, cracks and breaks. Inspect all parts for damage, corrosion and cleanliness.

CLEANING

After disassembly and inspection, cleaning of the parts can begin. Water service usually will produce mineral or lime deposits on metal parts in contact with water. These deposits can be cleaned by dipping the parts in a 5-percent muriatic acid solution just long enough for deposits to dissolve. This will remove most of the common types of deposits. **Caution: use extreme care when handling acid.** If the deposit is not removed by acid, then a fine grit (400) wet or dry sandpaper can be used with water. Rinse parts in water before handling. An appropriate solvent can clean parts used in fueling service. Dry with compressed air or a clean, lint-free cloth. Protect from damage and dust until reassembled.

REPAIR AND REPLACEMENT

Minor nicks and scratches may be polished out using a fine grade of emery or crocus cloth; replace parts if scratches cannot be removed.

Replace O-ring packing and gasket each time CV Flow Control is overhauled.

Replace all parts which are defective. Replace any parts which create the slightest doubt that they will not afford completely satisfactory operation. Use Inspection steps as a guide.

REASSEMBLY

Reassembly is the reverse of disassembly; no special tools are required.

TEST PROCEDURE

No testing of the flow Control is required prior to reassembly to the pilot control system on Cla-Val Main Valve.



CV

3/8" Flow Control

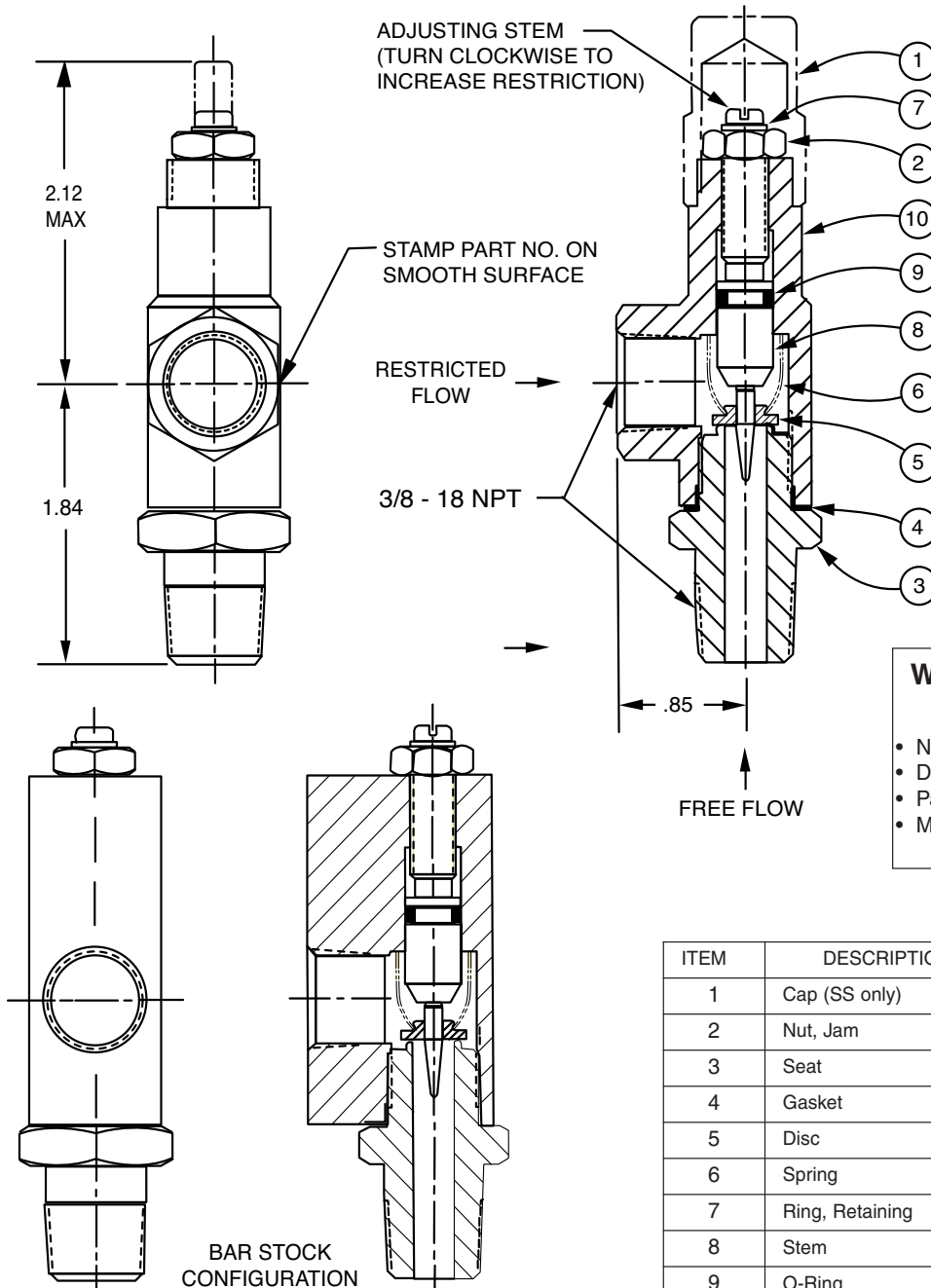

ITEM	DESCRIPTION	QTY
1	Cap (SS only)	1
2	Nut, Jam	1
3	Seat	1
4	Gasket	1
5	Disc	1
6	Spring	1
7	Ring, Retaining	1
8	Stem	1
9	O-Ring	1
10	Housing	1



—MODEL— **CDC-1**

Check Valve (Sizes 3/8" and 1/2")



- NSF 61 Approved
- Meets low lead requirements
- Soft Seat for Bubble Tight Shutoff, Spring Loaded for Fast Seating Action
- Compact Design
- Low Cracking Pressure 1/2 psi
- Flow Profile Designed to Minimize Head Loss
- Perfect Seating both at High and Low Pressure, Wide Temperature Range: +10° to 210°F
- Polyetherimide Disc to ensure the Best Resistance for Corrosion and Abrasion
- Patented Disc Guide to Prevent Any Side Loading

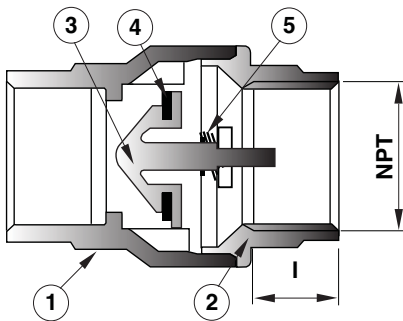

Full Open Operation

Item	Description	Material
1	Body	Brass
2	End Connection	Brass
3	Disc	Polyetherimide
4	Seat	NBR
5	Spring	Stainless Steel

Available only in replacement assembly.

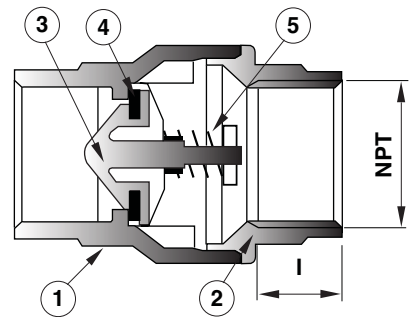

Tight Closing Operation

Dimensions

Size (NPT)	Stock Number	A	B	C	I	C _v	psi	Wt.
3/8"	9834501A	1.73	0.79	1.06	0.40	4.55	400	0.37
1/2"	9834502J	2.32	0.98	1.35	0.53	6.00	400	0.32

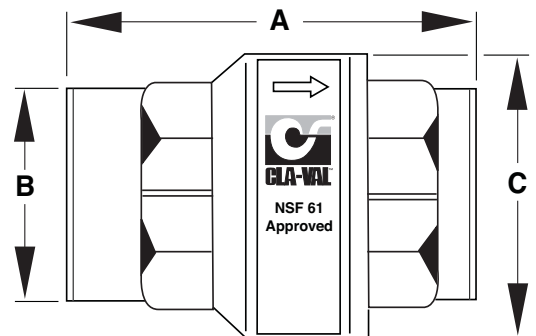



X43 Strainer

ITEM	DESCRIPTION	MATERIAL
1	Pipe Plug	Steel
2	Strainer Plug	Brass
3	Gasket	Copper
4	Screen	SST
5	Body	Brass

No parts available. Replacement assembly only.

Standard 60 mesh pilot system strainer for fluid service.

Size	Stock Number
3/8 x 3/8	33450J

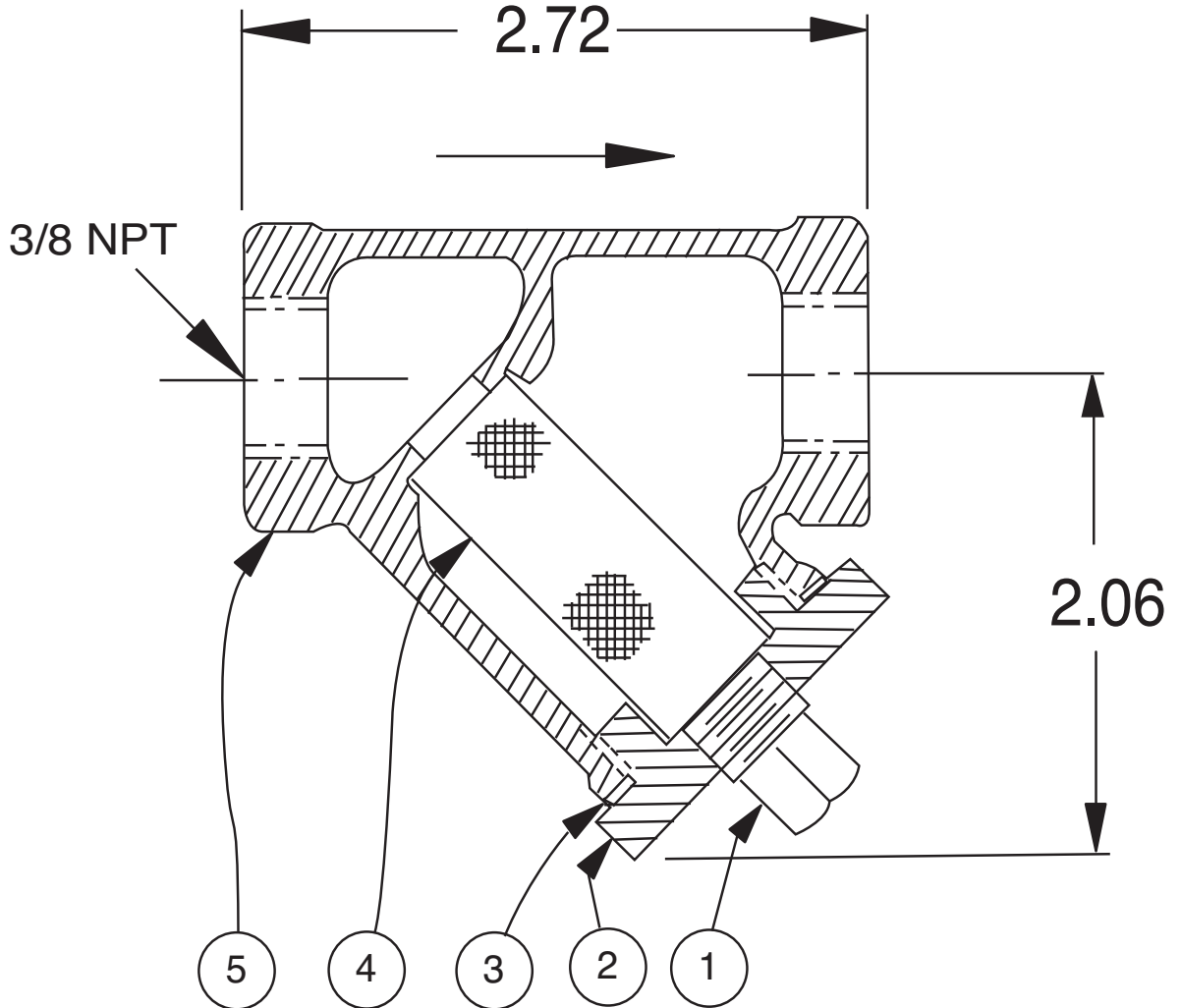



Cla-Val Product Identification

How to Order

Proper Identification

For ordering repair kits, replacement parts, or for inquiries concerning valve operation, it is important to properly identify Cla-Val products already in service by including all nameplate data with your inquiry. Pertinent product data includes valve function, size, material, pressure rating, end details, type of pilot controls used and control adjustment ranges.

Identification Plates

For product identification, cast-in body markings are supplemented by identification plates as illustrated on this page. The plates, depending on type and size of product, are mounted in the most practical position. **It is extremely important that these identification plates are not painted over, removed, or in any other way rendered illegible.**

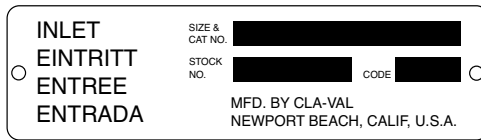

This brass plate appears on valves sized 2 1/2" and larger and is located on the top of the inlet flange.

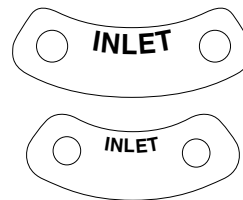

These two brass plates appear on 3/8", 1/2", and 3/4" size valves and are located on the valve cover.



This brass plate appears on altitude valves only and is found on top of the outlet flange.

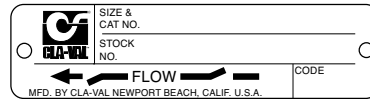

These two brass plates appear on threaded valves 1" through 3" size or flanged valves 1" through 2". It is located on only one side of the valve body.

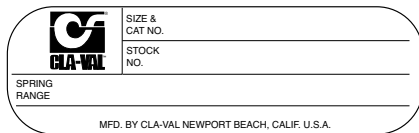

This tag is affixed to the cover of the pilot control valve. The adjustment range appears in the spring range section.

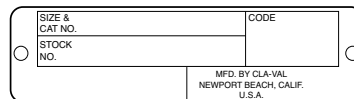

This brass plate is used to identify pilot control valves. The adjustment range is stamped into the plate.

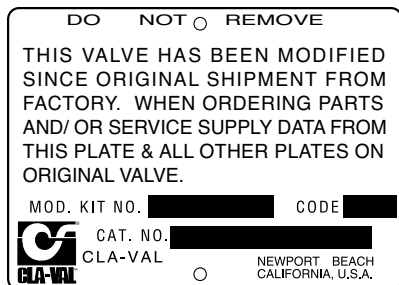

This aluminum plate is included in pilot system modification kits and is to be wired to the new pilot control system after installation.

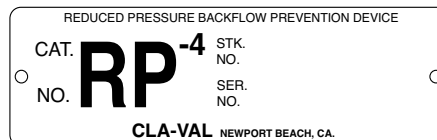

This brass plate is used on our backflow prevention assemblies. It is located on the side of the Number Two check (2" through 10"). The serial number of the assembly is also stamped on the top of the inlet flange of the Number One check.



HOW TO ORDER

Distributed By:
M&M Control Service, Inc.
Phone: 800-876-0036
Fax: 847-356-0747
Email: sales@mmcontrol.com

SPECIFY WHEN ORDERING

- Model Number
- Globe or Angle Pattern
- Adjustment Range
(As Applicable)
- Valve Size
- Threaded or Flanged
- Body and Trim Materials
- Optional Features
- Pressure Class

UNLESS OTHERWISE SPECIFIED

- Globe or angle pattern are the same price
 - Ductile iron body and bronze trim are standard
 - X46 Flow Clean Strainer or X43 "Y" Strainer are included
 - CK2 Isolation Valves are included in price on 4" and larger valve sizes (6" and larger on 600 Series)
-

NOTES:

NOTES:



CLA-VAL

Distributed By:
M&M Control Service, Inc.
Phone: 800-876-0036
Fax: 847-356-0747
Email: sales@mmcontrol.com

Represented By:



— MODEL — **REPAIR KITS**

Complete Replacement Diaphragm Assemblies for 100-01 and 100-20 Hytrol Main Valves

For: Hytrol Main Valves with Ductile Iron, Bronze Trim Materials—125/150 Pressure Class Only.
FACTORY ASSEMBLED

Includes: Stem, Disc Guide, Disc, Disc Retainer, Spacer Washers, Diaphragm, Diaphragm Washer and Stem Nut.

Valve Size	Diaphragm Assembly Stock Number		Valve Size	Diaphragm Assembly Stock Number	
	100-01	100-20		100-01	100-20
3/8" (Also 81-01)	49097K	N/A	6"	40456G	33273E
1/2" - 3/4" (Also 81-01)	C2518D	N/A	8"	45276D	40456G
1"	C2520K	N/A	10"	81752J	45276D
1 1/4"-1 1/2"	C2522 F	N/A	12"	85533J	81752J
2"	C2524B	N/A	14"	89067D	N/A
2 1/2"	C2523D	N/A	16"	89068B	85533J
3"	C2525J	C2524B	20"	N/A	89068B
4"	33273E	C2525J	24"	N/A	89068B

Repair Kits for 100-01/100-20 Hytrol Valves

For: Hytrol Main Valves—125/150 Pressure Class Only.

Includes: Diaphragm, Disc (or Disc Assembly) and spare Spacer Washers.

Buna-N® Standard Material				Viton (For KB Valves)			
Valve Size	Repair Kit Stock Number		Valve Size	Repair Kit Stock Number			
	100-01	100-20		100-01	100-20		
3/8" (Also 81-01)	9169801K	N/A	3/8" (Also 81-01)	9169806J	N/A		
1/2" - 3/4" (Also 81-01)	9169802H	N/A	1/2" - 3/4" (Also 81-01)	9169807G	N/A		
1"	9169803F	N/A	1"	9169808E	N/A		
1 1/4" - 1 1/2"	9169804D	N/A	1 1/4" - 1 1/2"	9169809C	N/A		
2"	9169805A	N/A	2"	9169810A	N/A		
2 1/2"	9169811J	N/A	2 1/2"	9169817F	N/A		
3"	9169812G	9169805A	3"	9169818D	9169810A		
4"	9169813E	9169812G	4"	9169819B	9169818D		
6"	9169815K	9169813E	6"	9169820K	9169819B		
8"	9817901D	9169815K	8"	9169834A	9169820K		
10"	9817902B	9817901D					
12"	9817903K	9817902B					
14"	9817904H	N/A					
16"	9817905E	9817903K					
20"	N/A	9817905E					
24"	9817906C	9817905E					

When ordering, please give complete nameplate data of the valve and/or control being repaired.
MINIMUM ORDER CHARGE APPLIES.

Repair Kits for 100-02/100-21 Powertrol and 100-03/100-22 Powercheck Main Valves

For: Powertrol and Powercheck Main Valves—125/150 Pressure Class Only

Includes: Diaphragm, Disc (or Disc Assembly) and O-rings and full set of spare Spacer Washers.

Valve Size	Kit Stock Number 100-02	Valve Size	Kit Stock Number	
			100-02 & 100-03	100-21 & 100-22
3/8"	9169901H	2 1/2"	9169910J	N/A
1/2" & 3/4"	9169902F	3"	9169911G	9169905J
1"	9169903D	4"	9169912E	9169911G
1 1/4" & 1 1/2"	9169904B	6"	9169913C	9169912E
	9169905J	8"	99116G	9169913C
		10"	9169939H	99116G
		12"	9169937B	9169939H

Repair Kits for 100-04/100-23 Hy-Check Main Valves

Larger Sizes: Consult Factory.

For: Hy-Check Main Valves—125/150 Pressure Class Only

Includes: Diaphragm, Disc and O-Rings and full set of spare Spacer Washers.

Valve Size	Kit Stock Number		Valve Size	Kit Stock Number	
	100-04	100-23		100-04	100-23
4"	20210901B	N/A	12"	20210905H	20210904J
6"	20210902A	20210901B	14"	20210906G	N/A
8"	20210903K	20210902A	16"	20210907F	20210905H
10"	20210904J	20210903K	20"	N/A	20210907F
			24"	N/A	20210907F

Repair Kits for Pilot Control Valves (In Standard Materials Only)

Larger Sizes: Consult Factory.

Includes: Diaphragm, Disc (or Disc Assembly), O-Rings, Gaskets or spare Screws as appropriate.

BUNA-N® (Standard Material)				VITON (For KB Controls)	
Pilot Control	Kit Stock Number	Pilot Control	Kit Stock Number	Pilot Control	Kit Stock Number
CDB	9170006C	CFM-7	1263901K	CDB-KB	9170012A
CDB-30	9170023H	CFM-7A	1263901K	CRA-KB	N/A
CDB-31	9170024F	CFM-9	12223E	CRD-KB (w/bucking spring)	9170008J
CDB-7	9170017K	CRA (w/bucking spring)	9170001D	CRL-KB	9170013J
CDH-2	18225D	CRD (w/bucking spring)	9170002B	CDHS-2BKB	9170010E
CDHS-2	44607A	CRD (no bucking spring)	9170003K	CDHS-2FKB	9170011C
CDHS-2B	9170004H	CRD-18	20275401K	CDHS-18KB (no bucking spring)	9170009G
CDHS-2F	9170005E	CRD-22	98923G	102C-KB	1726202D
CDHS-3C-A2	24657K	CRL (55F, 55L)	9170007A		
CDHS-8A	2666901A	CRL-4A	43413E		
CDHS-18	9170003K	CRL-5 (55B)	65755B		
CDS-4	9170014G	CRL-5A (55G)	20666E		
CDS-5	14200A	CRL-18	20309801C		
CDS-6	20119301A	CV	9170019F		
CDS-6A	20349401C	X105L (O-ring)	00951E	Buna-N®	
CFCM-M1	1222301C	102B-1	1502201F	CRD Disc Ret. (Solid)	C5256H
CFM-2	12223E	102C-2	1726201F	CRD Disc Ret. (Spring)	C5255K
		102C-3	1726201F		

Repair Assemblies (In Standard Materials Only)

Control	Description	Stock Number
CF1-C1	Pilot Assembly Only	89541H
CF1-CI	Complete Float Control less Ball and Rod	89016A
CFC2-C1	Disc, Distributor and Seals	2674701E
CSM 11-A2-2	Mechanical Parts Assembly	97544B
CSM 11-A2-2	Pilot Assembly Only	18053K
33A 1"	Complete Internal Assembly and Seal	2036030B
33A 2"	Complete Internal Assembly and Seal	2040830J

When ordering, please give complete nameplate data of the valve and/or control being repaired. **MINIMUM ORDER CHARGE APPLIES**