

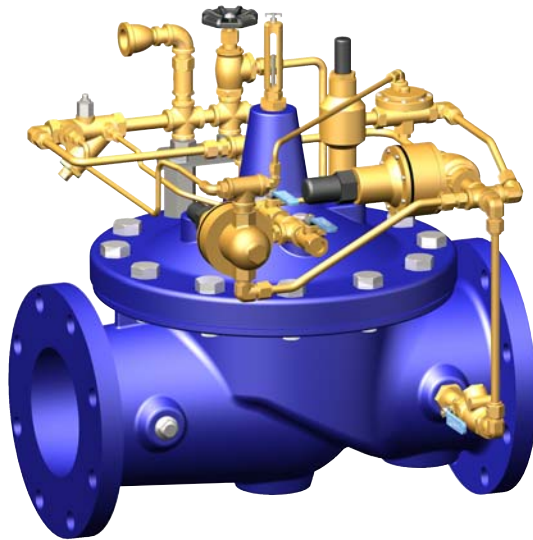

**52-03**  
 (Full Internal Port)  
 - MODEL -  
**652-03**  
 (Reduced Internal Port)

# Pressure Relief & Surge Anticipator Valve



- System Saver
- Protects Against Water Hammer Surges
- Opens on Initial Low Pressure Wave
- Closes Slowly to Prevent Subsequent Surges
- Adjustable Over a Wide Range of Settings

The Cla-Val Model 52-03/652-03 Surge Anticipator Valve is indispensable for protecting pumps, pumping equipment and all applicable pipelines from dangerous pressure surges caused by rapid changes of flow velocity within a pipeline.

When pumping systems are started and stopped gradually, harmful surges do not occur. Should a power failure take place, however the abrupt stopping of the pump can cause dangerous surges in the system which could result in severe equipment damage.

Power failure to a pump will usually result in a down surge in pressure, followed by an up surge in pressure. The surge control valve opens on the initial low pressure wave, diverting the returning high pressure wave from the system.\*In effect, the valve has anticipated the returning high pressure wave and is open to dissipate the damage causing surge. The valve will then close slowly without generating any further pressure surges.

\* An adjustable hydraulic flow control limits the valve opening for a controlled initial surge relief.

## Schematic Diagram

Item	Description
1	Hytrol (Main Valve)
2	X102F Flow Limiter
3	X101 Valve Position Indicator *
4	CK2 Isolation Valve
5	100-01 Hytrol (Reverse Flow)
6	CRL Pressure Relief Control
7	CRA Pressure Reducing Control
8	X58B Restriction Tube Assembly
9	CSC Swing Check Valve
10	X42N-3 Strainer Needle Valve
11	Bell Reducer
12	Pressure Gage
13	CK2 Isolation Valve
14	CK2 Isolation Valve

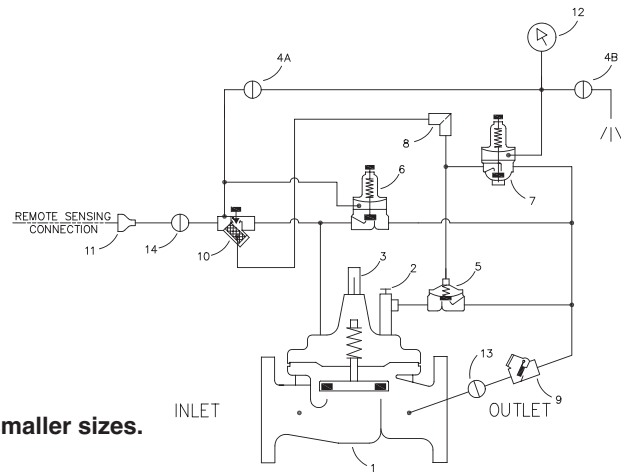

**\*Note: X101 or X105L Accessories not available in 4" and smaller sizes.**

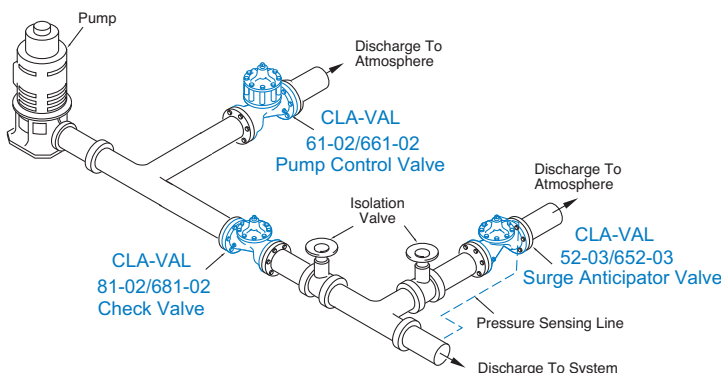

## Typical Application

The 52-03/652-03 discharges to atmosphere from a tee in the pump discharge header. The valve anticipates surges caused by power failure as well as acting as a standard overpressure relief valve.

Note: The remote pressure sensing line should be 3/4" minimum I.D. installed from the valve to the pipeline to avoid air pockets.

Note: We recommend protecting tubing and valve from freezing temperatures.



**Model 52-03** (Uses Basic Valve Model 100-01)

**Pressure Ratings** (Recommended Maximum Pressure - psi)

Valve Body & Cover		Pressure Class				
		Flanged		Grooved	Threaded	
Grade	Material	ANSI Standards*	150 Class	300 Class	300 Class	End‡ Details
ASTM A536	Ductile Iron	B16.42	250	400	400	400
ASTM A216-WCB	Cast Steel	B16.5	285	400	400	400
ASTM B62	Bronze	B16.24	225	400	400	400

Note: \* ANSI standards are for flange dimensions only.  
 Flanged valves are available faced but not drilled.  
 ‡ End Details machined to ANSI B2.1 specifications.  
**Valves for higher pressure are available; consult factory for details**

**Materials**

Component	Standard Material Combinations		
Body & Cover	Ductile Iron	Cast Steel	Bronze
Available Sizes	2-1/2" - 18"	2-1/2" - 16"	2-1/2" - 16"
Disc Retainer & Diaphragm Washer	Cast Iron	Cast Steel	Bronze
Trim: Disc Guide, Seat & Cover Bearing	Bronze is Standard Stainless Steel is Optional		
Disc	Buna-N® Rubber		
Diaphragm	Nylon Reinforced Buna-N® Rubber		
Stem, Nut & Spring	Stainless Steel		

For material options not listed, consult factory.  
 Cla-Val manufactures valves in more than 50 different alloys.

**Dimensions**  
(In inches)

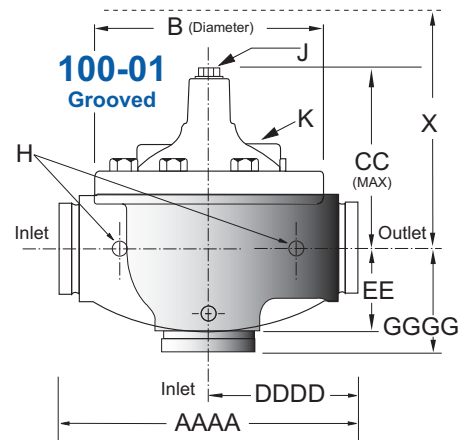
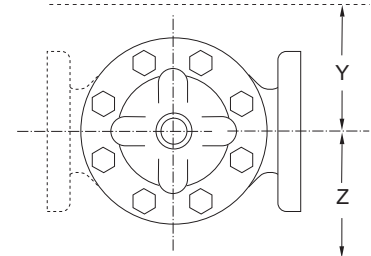
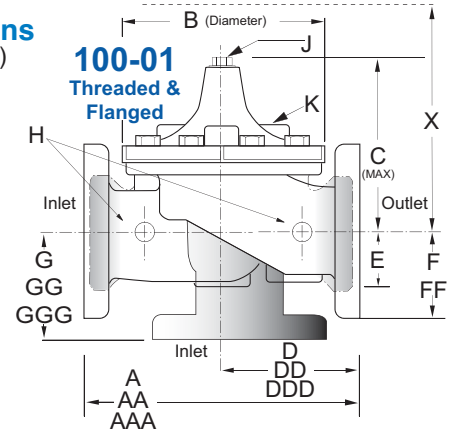

**Model 52-03 Dimensions** (In Inches)

Valve Size (Inches)	2 1/2	3	4	6	8	10	12	14	16	18
A Threaded	11.00	12.50	—	—	—	—	—	—	—	—
AA 150 ANSI	11.00	12.00	15.00	20.00	25.38	29.75	34.00	39.00	41.38	46.00
AAA 300 ANSI	11.62	13.25	15.62	21.00	26.38	31.12	35.50	40.50	43.50	47.64
AAAA Grooved End	11.00	12.50	15.00	20.00	25.38	—	—	—	—	—
B Dia.	8.00	9.12	11.50	15.75	20.00	23.62	28.00	32.75	35.50	41.50
C Max.	7.56	8.19	10.62	13.38	16.00	17.12	20.88	24.19	25.00	39.06
CC Max. Grooved End	6.88	7.25	9.31	12.12	14.62	—	—	—	—	—
D Threaded	5.50	6.25	—	—	—	—	—	—	—	—
DD 150 ANSI	5.50	6.00	7.50	10.00	12.69	14.88	17.00	19.50	20.81	—
DDD 300 ANSI	5.88	6.38	7.88	10.50	13.25	15.56	17.75	20.25	21.62	—
DDDD Grooved End	—	6.00	7.50	—	—	—	—	—	—	—
E	1.69	2.06	3.19	4.31	5.31	9.25	10.75	12.62	15.50	12.95
EE Grooved End	2.88	3.12	4.25	6.00	7.56	—	—	—	—	—
F 150 ANSI	3.50	3.75	4.50	5.50	6.75	8.00	9.50	10.50	11.75	15.00
FF 300 ANSI	3.75	4.13	5.00	6.25	7.50	8.75	10.25	11.50	12.75	15.00
G Threaded	4.00	4.50	—	—	—	—	—	—	—	—
GG 150 ANSI	4.00	4.00	5.00	6.00	8.00	8.62	13.75	14.88	15.69	—
GGG 300 ANSI	4.31	4.38	5.31	6.50	8.50	9.31	14.50	15.62	16.50	—
GGGG Grooved End	—	4.25	5.00	—	—	—	—	—	—	—
H NPT Body Tapping	.50	.50	.75	.75	1	1	1	1	1	1
J NPT Cover Center Plug	.50	.50	.75	.75	1	1	1.25	1.5	2	1.5
K NPT Cover Tapping	.50	.50	.75	.75	1	1	1	1	1	1
Stem Travel	0.7	0.8	1.1	1.7	2.3	2.8	3.4	4.0	4.5	5.1
Approx. Ship Wt. Lbs.	50	70	140	285	500	780	1165	1600	2265	2982
X Pilot System	14	15	17	29	31	33	36	40	40	43
Y Pilot System	10	11	12	20	22	24	26	29	30	32
Z Pilot System	10	11	12	20	22	24	26	29	30	32

Note: The top two flange holes on valve size 36 are threaded to 1 1/2"-6 UNC.

**Model 652-03** (Uses Basic Valve Model 100-20)

**Dimensions**  
(In inches)

**Pressure Ratings** (Recommended Maximum Pressure - psi)

Valve Body & Cover		Pressure Class		
		Flanged		
Grade	Material	ANSI Standards*	150 Class	300 Class
ASTM A536	Ductile Iron	B16.42	250	400
ASTM A216-WCB	Cast Steel	B16.5	285	400
ASTM B62	Bronze	B16.24	225	400

Note: \* ANSI standards are for flange dimensions only.  
Flanged valves are available faced but not drilled.  
**Valves for higher pressure are available; consult factory for details**

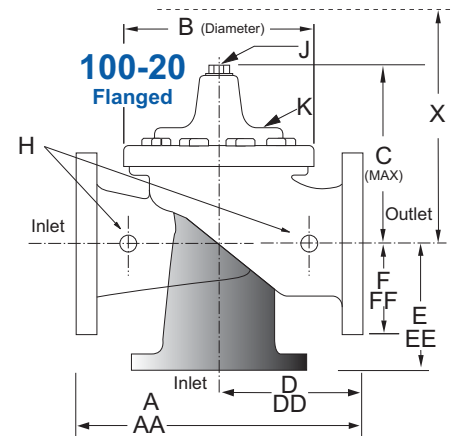

**Materials**

Component	Standard Material Combinations		
	Ductile Iron	Cast Steel	Bronze
Body & Cover	Ductile Iron	Cast Steel	Bronze
Available Sizes	3" - 24"	3" - 16"	3" - 16"
Disc Retainer & Diaphragm Washer	Cast Iron	Cast Steel	Bronze
Trim: Disc Guide, Seat & Cover Bearing	Bronze is Standard Stainless Steel is Optional		
Disc	Buna-N® Rubber		
Diaphragm	Nylon Reinforced Buna-N® Rubber		
Stem, Nut & Spring	Stainless Steel		

For material options not listed, consult factory.  
Cla-Val manufactures valves in more than 50 different alloys.

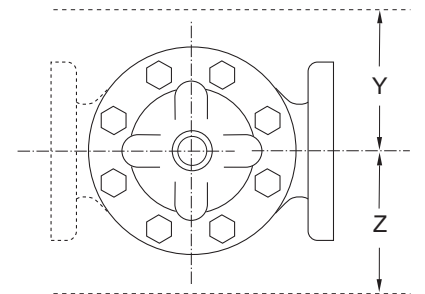

**Model 652-03 Dimensions** (In Inches)

Valve Size (Inches)	3	4	6	8	10	12	14	16	18	20	24
A 150 ANSI	10.25	13.88	17.75	21.38	26.00	30.00	34.25	35.00	42.12	48.00	48.00
AA 300 ANSI	11.00	14.50	18.62	22.38	27.38	31.50	35.75	36.62	43.63	49.62	49.75
B Dia.	6.62	9.12	11.50	15.75	20.00	23.62	27.47	28.00	35.44	35.44	35.44
C Max.	7.00	8.62	11.62	15.00	17.88	21.00	20.88	25.75	25.00	31.00	31.00
D 150 ANSI	—	6.94	8.88	10.69	CF*	CF*	CF*	CF*	CF*	CF*	CF*
DD 300 ANSI	—	7.25	9.38	11.19	CF*	CF*	CF*	CF*	CF*	CF*	CF*
E 150 ANSI	—	5.50	6.75	7.25	CF*	CF*	CF*	CF*	CF*	CF*	CF*
EE 300 ANSI	—	5.81	7.25	7.75	CF*	CF*	CF*	CF*	CF*	CF*	CF*
F 150 ANSI	3.75	4.50	5.50	6.75	8.00	9.50	11.00	11.75	15.88	14.56	17.00
FF 300 ANSI	4.12	5.00	6.25	7.50	8.75	10.25	11.50	12.75	15.88	16.06	19.00
H NPT Body Tapping	.375	.50	.75	.75	1	1	1	1	1	1	1
J NPT Cover Center Plug	.50	.50	.75	.75	1	1	1.25	1.25	2	2	2
K NPT Cover Tapping	.375	.50	.75	.75	1	1	1	1	1	1	1
Stem Travel	0.6	0.8	1.1	1.7	2.3	2.8	3.4	3.4	4.5	4.5	4.5
Approx. Ship Wt. Lbs.	45	85	195	330	625	900	1250	1380	1500	2551	2733
X Pilot System	13	15	27	30	33	36	36	41	40	46	55
Y Pilot System	10	11	18	20	22	24	26	26	30	30	30
Z Pilot System	10	11	18	20	22	24	26	26	30	30	30

\*Consult Factory

Note: The top two flange holes on valve sizes 36 thru 48 are threaded to 1 1/2"-6 UNC.

<b>52-03 Valve Selection</b>	<b>100-01 Pattern:</b> Globe (G), Angle (A), <b>End Connections:</b> Threaded (T), Grooved (GR), Flanged (F) Indicate Available Sizes										
	Inches	2½	3	4	6	8	10	12	14	16	18
	mm	65	80	100	150	200	250	300	350	400	450
Basic Valve 100-01	Pattern	G, A	G, A	G, A	G, A	G, A	G, A	G, A	G, A	G, A	G
	End Detail	T, F, Gr*	T, F, Gr	F, Gr	F, Gr*	F, Gr*	F	F	F	F	F
Suggested Flow (gpm)	Maximum	300	460	800	1800	3100	4900	7000	8400	11000	14000
	Maximum Surge	670	1000	1800	4000	7000	11000	16000	19000	25000	31000
Suggested Flow (Liters/Sec)	Maximum	19	29	50	113	195	309	442	530	694	883
	Maximum Surge	42	63	113	252	441	693	1008	1197	1577	1956

100-01 Series is the full internal port Hytrol.

\*Globe Grooved Only

<b>652-03 Valve Selection</b>	<b>100-20 Pattern:</b> Globe (G), Angle (A), <b>End Connections:</b> Flanged (F) Indicate Available Sizes											
	Inches	3	4	6	8	10	12	14	16	18	20	24
	mm	80	100	150	200	250	300	350	400	450	500	600
Basic Valve 100-20	Pattern	G	G, A	G, A	G, A	G	G	G	G	G	G	G
	End Detail	F	F	F	F	F	F	F	F	F	F	F
Suggested Flow (gpm)	Maximum	260	580	1025	2300	4100	6400	9230	9230	16500	16500	16500
	Maximum Surge	440	990	1760	3970	7050	11000	15900	15900	28200	28200	28200
Suggested Flow (Liters/Sec)	Maximum	16	37	65	145	258	403	581	581	1040	1040	1040
	Maximum Surge	28	62	111	250	444	693	1002	1002	1777	1777	1777

100-20 Series is the reduced internal port size version of the 100-01 Series.

**Sizing Information:** Because of the many variable conditions that generally exist in any given system, proper sizing is important. Incorrect valve sizing will nullify the ability of the Surge Anticipator Valve. For valve sizing assistance, contact Cla-Val with the following specific pump and system information: number and type of pumps; shutoff head; flow rate; discharge static head and pumping head; pipe size; length; thickness and material.

### Pilot System Specifications

#### Adjustment Ranges

##### High Pressure Pilot (CRL)

- 0 to 75 psi
- 20 to 200 psi \*
- 100 to 300 psi
- 250 to 600 psi

##### Low Pressure Pilot (CRA)

- 2 to 30 psi
- 15 to 75 psi
- 30 to 300 psi \*

\*Supplied unless otherwise specified  
Other ranges available, please consult factory

#### Temperature Range

Water: to 180°F

#### Materials

##### Standard Pilot System Materials

- Pilot Control: Bronze ASTM B62
- Trim: Stainless Steel 303
- Rubber: Buna-N® Synthetic Rubber
- Tubing & Fittings: Copper and Bronze

##### Optional Pilot System Materials

Pilot systems are available with optional Aluminum, Stainless Steel or Monel materials.

### When Ordering, Please Specify

1. Catalog No. 52-03 or No. 652-03
2. Valve Size
3. Pattern - Globe or Angle
4. Pressure Class
5. Threaded or Flanged
6. Trim Material
7. Adjustment Range
8. Desired Options
9. When Vertically Installed
10. Product Enhancement