

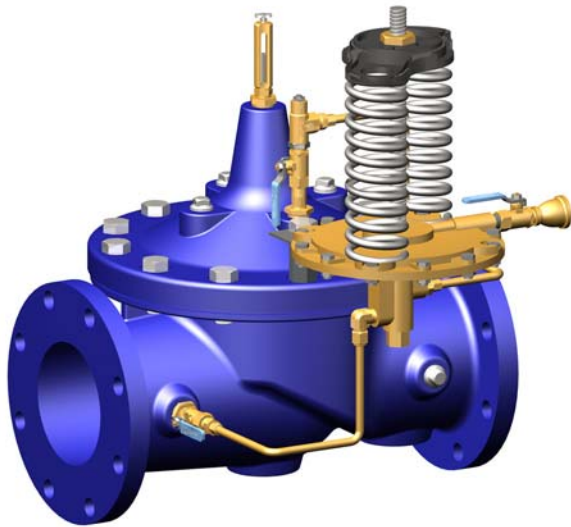

**210-09**  
(Full Internal Port)  
**MODEL**  
**610-09**  
(Reduced Internal Port)

# Combination Altitude and Back Pressure Valve



- Accurate and Repeatable Level Control
- Prevents Low Supply Pressure When Filling
- Drip Tight Positive Shut-Off
- Reliable Hydraulic Operation
- Easily Adjustable Controls

The Cla-Val Model 210-09/610-09 Combination Altitude and Back Pressure Valve controls the high water level in reservoirs without the need for floats or other devices. The valve modulates to maintain upstream pressure within close limits to prevent over drawing system supply while filling reservoir. When the shut-off point of the hydraulic pilot control is reached, the valve closes smoothly without surges. This valve is designed for one-way flow only.

The 210-09/610-09 Valve is hydraulically-operated and pilot-controlled for optimum automatic level and pressure control. The level pilot control operates on a differential in forces between spring load and reservoir head level. When force of spring is overcome by force of reservoir head, the pilot shifts and closes main valve. Desired high water level is set by adjusting spring force. The level pilot control measures the reservoir head through a customer supplied separate sensing line\* connected directly to reservoir. The pressure sustaining pilot control senses upstream system pressure and modulates the main valve more open on a rise in pressure to maintain a minimum inlet pressure when filling reservoir.

The valve can also be furnished with auxiliary controls to meet the need for additional functions, such as: rate of flow control, pressure reduction, solenoid override, etc. If the check feature option is added and a pressure reversal occurs, reservoir pressure is admitted into main valve cover chamber and valve closes to prevent return flow.

## Schematic Diagram

Item	Description
1	Hytrol (Main Valve)
2	CDS6A Altitude Control
3	X101 Valve Position Indicator
4	Bell Reducer
5	CRL Pressure Relief Valve
6.	100-01 Hytrol (Reverse Flow)
7	X42N-3 Strainer

## Optional Features

Item	Description
B	CK2 (Isolation Valve)
D	Check Valve with Isolation Valve
F	Remote Pilot Sensing
S	CV Flow Control (Opening)

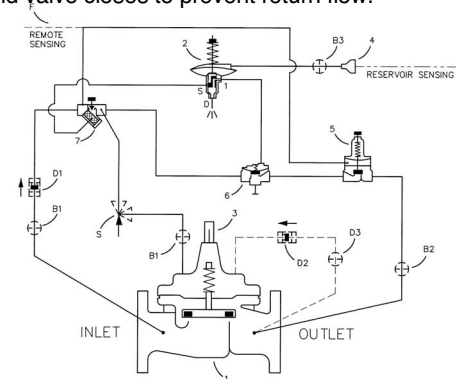

## Typical Applications

Used on reservoirs where water is withdrawn through a separate line or through a bypass equipped with a check valve. Valve closes at the desired high water level and reopens for filling when reservoir head lowers below the shut off level. Valve controls minimum supply pressure to keep from overdrawing supply while filling reservoir. Water in excess of system pressure flows to reservoir at controlled rate. For more information see data sheet E-CDS6A.

\*Note: The reservoir pressure sensing line should be 3/4" minimum I.D. installed with a 2° slope from the valve to the reservoir to avoid air pockets.

Note: We recommend protecting tubing and valve from freezing temperatures.

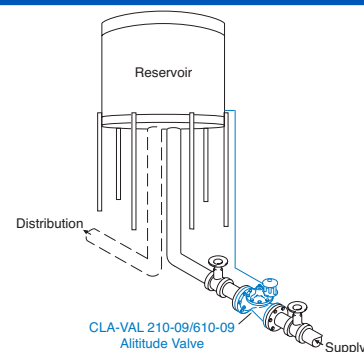

**Model 210-09** (Uses Basic Valve Model 100-01)

**Pressure Ratings** (Recommended Maximum Pressure - psi)

Valve Body & Cover		Pressure Class			
		Flanged		Threaded	
Grade	Material	ANSI Standards*	150 lb.	300 lb.	End** Details
ASTM A536	Ductile Iron	B16.42	250	400	400
ASTM A216-WCB	Cast Steel	B16.5	285	400	400
ASTM B62	Bronze	B16.24	225	400	400

Note: \* ANSI standards are for flange dimensions only.  
 Flanged valves are available faced but not drilled.  
 \*\* End Details machined to ANSI B2.1 specifications.

**Materials**

Component	Standard Material Combinations		
Body & Cover	Ductile Iron	Cast Steel	Bronze
Available Sizes	2" - 36"	2" - 16"	2" - 16"
Disc Retainer & Diaphragm Washer	Cast Iron	Cast Steel	Bronze
Trim: Disc Guide, Seat & Cover Bearing	Bronze is Standard Stainless Steel is Optional		
Disc	Buna-N® Rubber		
Diaphragm	Nylon Reinforced Buna-N® Rubber		
Stem, Nut & Spring	Stainless Steel		

For material options not listed, consult factory.  
 Cla-Val manufactures valves in more than 50 different alloys.

**Dimensions**

(In inches)

100-01 (Globe)

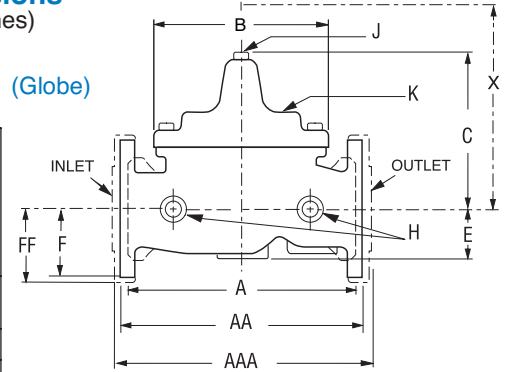

**Cover Capacity**

Liquid Volume Displaced from Diaphragm Chamber When Valve Opens or Closes

Valve Size	Displacement
2"	.032 gal
2 1/2"	.043 gal
3"	.080 gal
4"	.169 gal
6"	.531 gal
8"	1.26 gal
10"	2.51 gal
12"	4.00 gal
14"	6.50 gal
16"	9.57 gal
24"	29.00 gal
36"	42.00 gal

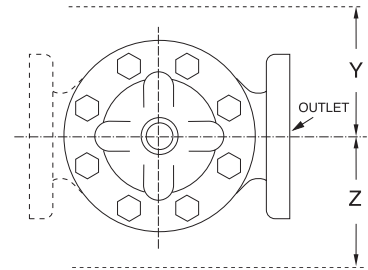

100-01 (Angle)

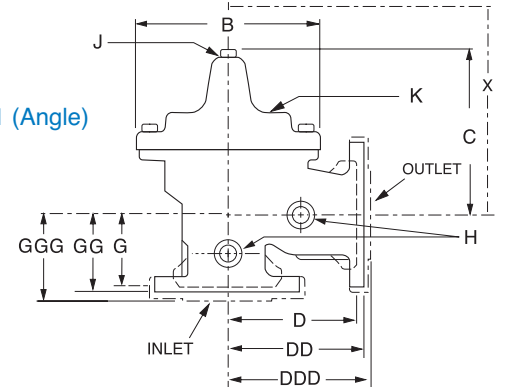

**Model 210-09 Dimensions** (In Inches)

Valve Size (Inches)	2	2 1/2	3	4	6	8	10	12	14	16	24	36
A Threaded	9.38	11.00	12.50	—	—	—	—	—	—	—	—	—
AA 150 ANSI	9.38	11.00	12.00	15.00	20.00	25.38	29.75	34.00	39.00	41.38	61.50	76.00
AAA 300 ANSI	10.00	11.62	13.25	15.62	21.00	26.38	31.12	35.50	40.50	43.50	63.24	78.00
B Dia.	6.62	8.00	9.12	11.50	15.75	20.00	23.62	28.00	32.75	35.50	53.16	66.00
C Max.	6.50	7.56	8.19	10.62	13.38	16.00	17.12	20.88	24.19	25.00	43.93	61.50
D Threaded	4.75	5.50	6.25	—	—	—	—	—	—	—	—	—
DD 150 ANSI	4.75	5.50	6.00	7.50	10.00	12.75	14.88	17.00	19.50	20.81	—	—
DDD 300 ANSI	5.00	5.88	6.38	7.88	10.50	13.25	15.56	17.75	20.25	21.62	—	—
E	1.50	1.69	2.56	3.19	4.31	5.31	9.25	10.75	12.62	15.50	17.75	24.56
F 150 ANSI	3.00	3.50	3.75	4.50	5.50	6.75	8.00	9.50	10.50	11.75	19.25	28.00
FF 300 ANSI	3.25	3.75	4.13	5.00	6.25	7.50	8.75	10.25	11.50	12.75	—	—
G Threaded	3.25	4.00	4.50	—	—	—	—	—	—	—	—	—
GG 150 ANSI	3.25	4.00	4.00	5.00	6.00	8.00	8.62	13.75	14.88	15.69	—	—
GGG 300 ANSI	3.50	4.31	4.38	5.31	6.50	8.50	9.31	14.50	15.62	16.50	—	—
H NPT Body Tapping	3/8	1/2	1/2	3/4	3/4	1	1	1	1	1	1	2
J NPT Cover Center Plug	1/2	1/2	1/2	3/4	3/4	1	1	1 1/4	1 1/2	2	1 1/2	2
K NPT Cover Tapping	3/8	1/2	1/2	3/4	3/4	1	1	1	1	1	1	2
Valve Stem Internal Thread UNF	10-32	10-32	1/4-28	1/4-28	5/16-24	3/8-24	1/2-24	5/8-24	3/4-24	7/8-24	1-20	1 1/4-16
Stem Travel	0.6	0.7	0.8	1.1	1.7	2.3	2.8	3.4	4.0	4.5	6.75	10.12
Approx. Ship Wt. Lbs.	35	50	70	140	285	500	780	1165	1600	2265	6200	11470
X Pilot System	13.00	14.00	15.00	17.00	29.00	31.00	33.00	36.00	40.00	40.00	68.00	86.00
Y Pilot System	9.00	10.00	11.00	12.00	20.00	22.00	24.00	26.00	29.00	30.00	39.00	45.00
Z Pilot System	9.00	10.00	11.00	12.00	20.00	22.00	24.00	26.00	29.00	30.00	39.00	45.00

**Model 610-09** (Uses Basic Valve Model 100-20)

**Dimensions**  
(In inches)

**Pressure Ratings** (Recommended Maximum Pressure - psi)

Valve Body & Cover		Pressure Class		
		Flanged		
Grade	Material	ANSI Standards*	150 lb.	300 lb.
ASTM A536	Ductile Iron	B16.42	250	400
ASTM A216-WCB	Cast Steel	B16.5	285	400
ASTM B62	Bronze	B16.24	225	400

Note: \*ANSI standards are for flange dimensions only. Flanged valves are available faced but not drilled.

**Cover Capacity**

Liquid Volume Displaced from Diaphragm Chamber When Valve Opens or Closes

Valve Size	Displacement
3"	.032 gal
4"	.080 gal
6"	.169 gal
8"	.531 gal
10"	1.26 gal
12"	2.51 gal
14"	2.51 gal
16"	4.00 gal
18"	4.00 gal
20"	9.57 gal
24"	9.57 gal
30"	29.00 gal

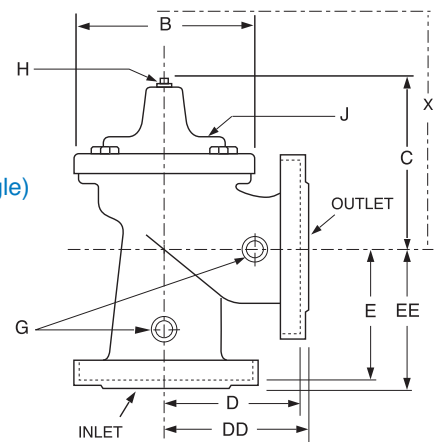
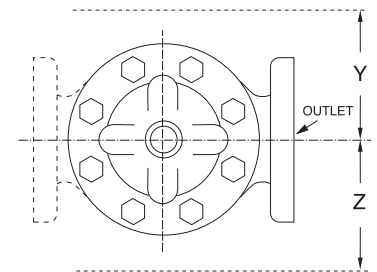
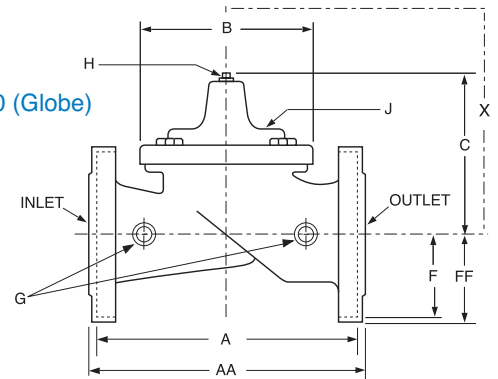

























































**Materials**

Component	Standard Material Combinations		
Body & Cover	Ductile Iron	Cast Steel	Bronze
Available Sizes	3" - 48"	3" - 16"	3" - 16"
Disc Retainer & Diaphragm Washer	Cast Iron	Cast Steel	Bronze
Trim: Disc Guide, Seat & Cover Bearing	Bronze is Standard Stainless Steel is Optional		
Disc	Buna-N® Rubber		
Diaphragm	Nylon Reinforced Buna-N® Rubber		
Stem, Nut & Spring	Stainless Steel		

For material options not listed, consult factory. Cla-Val manufactures valves in more than 50 different alloys.

**Model 610-09 Dimensions** (In Inches)

Valve Size (Inches)	3	4	6	8	10	12	14	16	18	20	24	30
<b>A</b> 150 ANSI	10.25	13.88	17.75	21.38	26.00	30.00	34.25	35.00	42.12	48.00	48.00	63.25
<b>AA</b> 300 ANSI	11.00	14.50	18.62	22.38	27.38	31.50	—	36.62	43.63	49.62	49.75	—
<b>B</b> Dia.	6.62	9.12	11.50	15.75	20.00	23.62	28.00	28.00	35.44	35.44	35.44	53.19
<b>C</b> Max.	7.00	8.62	11.62	15.00	17.88	21.00	20.88	25.75	25.00	31.00	31.00	43.94
<b>D</b> 150 ANSI	—	6.94	8.88	10.69	—	—	—	—	—	—	—	—
<b>DD</b> 300 ANSI	—	7.25	9.38	11.19	—	—	—	—	—	—	—	—
<b>E</b> 150 ANSI	—	5.50	6.75	7.25	—	—	—	—	—	—	—	—
<b>EE</b> 300 ANSI	—	5.81	7.25	7.75	—	—	—	—	—	—	—	—
<b>F</b> 150 ANSI	3.75	4.50	5.50	6.75	8.00	9.50	11.00	11.75	15.88	14.56	17.00	19.88
<b>FF</b> 300 ANSI	4.12	5.00	6.25	7.50	8.75	10.25	—	12.75	15.88	16.06	19.00	—
<b>H</b> NPT Body Tapping	3/8	1/2	3/4	3/4	1	1	1	1	1	1	1	1
<b>J</b> NPT Cover Center Plug	1/2	1/2	3/4	3/4	1	1	1 1/4	1 1/4	2	2	2	2
<b>K</b> NPT Cover Tapping	3/8	1/2	3/4	3/4	1	1	1	1	1	1	1	1
Valve Stem Internal Thread UNF	10-32	1/4-28	1/4-28	3/8-24	3/8-24	3/8-24	3/8-24	3/8-24	1/2-20	1/2-20	1/2-20	3/4-16
Stem Travel	0.6	0.8	1.1	1.7	2.3	2.8	3.4	3.4	3.4	4.5	4.5	6.5
Approx. Ship Wt. Lbs.	45	85	195	330	625	900	1250	1380	1500	2551	2733	6500
<b>X</b> Pilot System	13.00	15.00	27.00	30.00	33.00	36.00	36.00	41.00	40.00	46.00	55.00	68.00
<b>Y</b> Pilot System	10.00	11.00	18.00	20.00	22.00	24.00	26.00	26.00	30.00	30.00	30.00	39.00
<b>Z</b> Pilot System	10.00	11.00	18.00	20.00	22.00	24.00	26.00	26.00	30.00	30.00	30.00	39.00

Valve Selection		These Symbols  and  Indicate Available Sizes															
		Inches	2	2½	3	4	6	8	10	12	14	16	18	20	24	30	36
		mm	50	65	80	100	150	200	250	300	350	400	450	500	600	750	900
		End Detail	Threaded & Flanged						Flanged								
Model 210 Series	Basic Valve 100-01	Globe															
		Angle															
	Suggested Flow (gpm)	Max. Continuous	210	300	460	800	1800	3100	4900	7000	8400	11000			25000		50000
		Max. Intermittent	260	370	580	990	2250	3900	6150	8720	10540	13700			31300		62500
	Suggested Flow (Liters/Sec)	Max. Continuous	13	19	29	50	113	195	309	441	529	693			1575		3150
Max. Intermittent		16.4	23	37	62	142	246	387	549	664	863			1972		3940	
Model 610 Series	Basic Valve 100-20	Globe															
		Angle															
	Suggested Flow (gpm)	Max. Continuous			260	580	1025	2300	4100	6400	9230	9230	16500	16500	16500	28000	
		Max. Intermittent															
	Suggested Flow (Liters/Sec)	Max. Continuous			16	37	65	145	258	403	581	581	1040	1040	1040	1764	
Max. Intermittent																	

610 Series is the reduced internal port size version of the 210 Series.

\*\*Flanged End Detail Only

For 100-01 basic valves, suggested flow calculations were based on flow through Schedule 40 Pipe. Maximum continuous flow is approx. 20 ft/sec (6.1 meters/sec) & maximum intermittent is approx. 25 ft/sec (7.6 meters/sec) and minimum continuous flow is approx. 1 ft/sec (.3 meters/sec). For 100-20 basic valves, suggested flow calculations were based on flow through the valve seat. Approx. 26 ft/sec (7.9 meters/sec) was used for maximum continuous flow & 1 ft/sec (.3 meters/sec) is used for minimum continuous flow. Maximum continuous flow through the valve seat for the 30" 100-20 is approx. 20 ft/sec (6.1 meters/sec).

**Pressure Ratings** (Recommended Maximum Pressure - psi)

Valve Body & Cover		Pressure Class			
		Flanged			Threaded
Grade	Material	ANSI Standards*	150 lb.	300 lb.	End** Details
ASTM A536	Ductile Iron	B16.42	250	400	400
ASTM A216-WCB	Cast Steel	B16.5	285	400	400
ASTM B62	Bronze	B16.24	225	400	400

Note: \* ANSI standards are for flange dimensions only.  
 Flanged valves are available faced but not drilled.  
 \*\* End Details machined to ANSI B2.1 specifications.

**Materials**

Component	Standard Material Combinations		
Body & Cover	Ductile Iron	Cast Steel	Bronze
Available Sizes			
100-01 Series Hytrol	2" - 36"	2" - 16"	2" - 16"
600 Series Hytrol	3" - 48"	3" - 16"	3" - 16"
Disc Retainer & Diaphragm Washer	Cast Iron	Cast Steel	Bronze
Trim: Disc Guide, Seat & Cover Bearing	Bronze is Standard Stainless Steel is optional		
Disc	Buna-N® Rubber		
Diaphragm	Nylon Reinforced Buna-N® Rubber		
Stem, Nut & Spring	Stainless Steel		

For material options not listed, consult factory.  
 Cla-Val manufactures valves in more than 50 different alloys.

**210 Series/610 Series Pilot System Specifications**

**Temperature Range, and Materials Apply to all 210 Series/610 Series**

Notes:  
 If flowing line pressure is less than 10 psi, consult factory for full details.

**Temperature Range**

Water: to 180°F

**Materials**

Standard Pilot System Materials

- Pilot Control: Bronze ASTM B62
- Trim: Stainless Steel Type 303
- Rubber: Buna-N® Synthetic Rubber

Optional Pilot System Materials

- Pilot Systems are available with optional Aluminum, Stainless Steel, or Monel materials at extra cost.
- Valve position indicator is standard

**Pilot System Adjustment Ranges**

**Model 210-01/610-01**

**CDS6A Pilot**

- 5 to 40 ft.
- 30 to 80 ft.
- 70 to 120 ft.
- 110 to 160 ft.
- 150 to 200 ft.

**Model 210-02/610-03**

**CDS6A Pilot**

- 5 to 40 ft.
- 30 to 80 ft.
- 70 to 120 ft.
- 110 to 160 ft.
- 150 to 200 ft.

**Model 210-03/610-03**

**CDS6A Pilot**

- 5 to 40 ft.
- 30 to 80 ft.
- 70 to 120 ft.
- 110 to 160 ft.
- 150 to 200 ft.

**Model 210-16/610-16**

**CDS6A Pilot**

- 5 to 40 ft.
- 30 to 80 ft.
- 70 to 120 ft.
- 110 to 160 ft.
- 150 to 200 ft.

\*Supplied unless otherwise specified Other ranges available, please consult factory